









*Nature,*  
February 10, 1923]

# Nature

A WEEKLY

ILLUSTRATED JOURNAL OF SCIENCE

VOLUME CX

JULY, 1922, to DECEMBER, 1922



*"To the solid ground  
Of Nature trusts the mind which builds for aye."*—WORDSWORTH.

London  
MACMILLAN AND CO., LIMITED  
NEW YORK: MACMILLAN COMPANY





505.42

N28

V. 110

Jul.-Dec.

1923

# INDEX.

## NAME INDEX.

- Abbot (Dr. C. G.), F. E. Fowle, and L. B. Aldrich, *Annals of the Astrophysical Observatory of the Smithsonian Institution*, Vol. iv., 608
- Abel (Prof. O.), awarded the D. G. Elliot Gold Medal of the National Academy of Sciences of the U.S.A., 188
- Abercrombie (L.), elected Professor of English Language and Literature in Leeds University, 530
- Abetti (Prof. G.), *The Mass and Proper Motion of 40 Eridani*, 854
- Acharyar (Rai Bahadar K. Ranga), assisted by C. T. Mudaliyar, *A Handbook of some South Indian Grasses*, 376
- Adair (E. W.), *Origin of the Name of the Genus Masaris*, 574
- Adami (Dr. J. G.), *Eugenics and the Improvement of the Human Race*, 853
- Adams and Joy, *Spectroscopic Parallaxes for Type A*, 584
- Adams (Prof. R. L.), *Farm Management: a Text-book for Student, Investigator, and Investor*, 404
- Adrian (Dr. E. D.), *On the Reality of Nerve-energy*, 447
- Aitchison (Dr. L.), *Engineering Steels*, 537
- Alcock (Lt.-Col. A.), *Discoveries in Tropical Medicine*, 114
- Algué (Rev. J.), *The Manila Typhoon of May 23, 1922*, 795
- Allbutt (Sir T. Clifford), presented with the Gold Medal of the British Medical Association, 294
- Allcut (Prof. E. A.) and C. J. King, *Engineering Inspection*, 730
- Allen (Dr. E. J.), *The Progression of Life in the Sea*, 353, 448
- Allen (Dr. F. J.), *Seasonal Incidence of the Births of Eminent People*, 40
- Allen (H. N.), *Periodic Structure of Atoms and Elements*, 415
- Allen (Dr. H. S.), *An Atomic Model with Stationary Electrons*, 310; appointed Professor of Natural Philosophy in St. Andrews University, 653
- Allis, Jr. (E. P.), *The Cranial Anatomy of Polypterus*, 748
- Alverdes (Dr. F.), *Studien an Infusorien über Flimmerbewegung, Lokomotion und Reizbeantwortung*, 509
- Ameghino (Florentino), *Obras completas y correspondencia científica de*. Vol. 3: *Dirigida por A. J. Torcelli*, 540
- Amenomiya (Y.), *The Devitrification caused upon the Surface of Sheet Glass by Heat*, 63
- Andant (A.), *The Variations of Critical Opalescence with the Filling of the Tubes and the Nature of the Liquids studied*, 63
- Andrade (Prof. E. N. da C.), *Action of Cutting Tools*, 876; *Occult Phenomena and After-images*, 843
- Andrade (J.), *Three Classes of Non-maintained Isochronal Vibrations and three Types of Timepieces*, 63
- André (G.), *The Filtration of Plant Juices*, 300
- Andrew (J. H.) and R. Higgins, *Grain-size and Diffusion*, 467
- Andrews (E. C.), *The Coral-bearing Limestones of the Cainozoic within the Pacific*, 168
- Anandale (Dr. N.) and Maj. R. B. S. Sewell, *An Indian Pond-snail*, 855
- Annett (H. E.), and M. N. Bose, *The Estimation of Narcotine and Papaverine in Opium*, 722; and R. R. Sanghi, *The Estimation of Codeine*, 722
- Appleton (Dr. A. B.), awarded the Raymond Horton-Smith prize of Cambridge University, 828; *The Interpretation of the Pelvic Region and Thigh of Monotremata*, 862; and F. Goldby, *The Innervation of the Pubi-tibialis (sartorius) Muscle of Reptilia*, 862; D. G. Reid, A. Hopkinson, and V. C. Pennell appointed demonstrators in anatomy in Cambridge University, 530
- Arber (E. A. Newell), *Critical Studies of Coal-measure Plant Impressions*, 27
- Aristotle, *The Works of*, translated into English: De Caelo, J. L. Stocks; De Generatione et Corruptione, Prof. H. H. Joachim, 174
- Arkwright (J. A.), *Virus Diseases in Animals and Man*, 622
- Armellini (Prof. G.), *The Orbital Distances of Satellites and Minor Planets*, 260
- Armitage (F. P.), *Diet and Race: Anthropological Essays*, 308
- Armstrong (Dr. E. F.), *A Monument to a Master Chemist*, 142; and T. P. Hilditch, *A Study of Catalytic Actions at Solid Surfaces. Parts viii. and ix.*, 62
- Armstrong (G. M.), *Sulphur Nutrition*, 128
- Armstrong (Prof. H. E.), *A New Worship? 700; Chemical Change and Catalysis (Messel Lecture)*, 367; *Rhapsodies culled from the Thionic Epos*; presented with the Messel Medal, 130; *The British Association*, 341; *The Peril of Milk*, 648
- Arnold (Sir T. W.), *Indian Painting and Mohammedan Culture*, 228
- d'Arsonval, Bordas, and Touplian, *The Glacial Waters of Argentiére and Bossons*, 27
- Artschwager (Dr. E.) and E. M. Smiley, *Dictionary of Botanical Equivalents: French-English, German-English*, 177
- Ashworth (Prof. J. H.), *On Rhinosporidium seeberi*, with special reference to its sporulation and affinities, 723
- Ashworth (Dr. J. R.), *An Experimental Confirmation of the Kinetic and Molecular Theories of Magnetism*, 10
- Aston (Dr. F. W.), awarded the Hughes Medal of the Royal Society, 674, 788; awarded the Nobel Prize for Chemistry for 1922, 674; *The Atoms of Matter: their Size, Number, and Construction*, 702; *The Isotopes of Antimony*, 732; *The Isotopes of Selenium and some other Elements*, 664; *The Mass-spectrum of Iron*, 312
- Athanasu (G.), *An Actinometer with Electrodes of Mercury covered with a thin layer of Mercurous Chloride, Bromide, Fluoride, or Sulphide*, 299
- Atkins (W. R. G.), *The Hydrogen Concentration of Natural Waters and some Etching Reagents in relation to Action of Metals*, 758
- Atkinson (R. d'E.), *Gas Pressures and the Second Law of Thermodynamics*, 112
- Aubry (A.) and E. Dormoy, *An Arsenical Glucoside: Diglucosidiodioxydiamino-arsenobenzene*, 759
- Auger (P.) and F. Perrin, *The Shocks between  $\alpha$ -particles and Atomic Nuclei*, 400
- Austen (Major E. E.), *Attack on a Drone-fly by a Wasp*, 323
- Austin (L. S.), *The Metallurgy of the Common Metals: Gold, Silver, Iron (and Steel), Copper, Lead, and Zinc*. Fifth edition, 71

- B. (F. A.), Origin of the Name of the Genus *Masaris*, 574  
 Baade (Dr.), A New Comet, 584; Variable Stars near M. 53, 364  
 Backhurst (I.), Variation of the Intensity of reflected X-radiation with the Temperature of the Crystal, 654  
 Baeyer (Prof. A. von), a statue of, unveiled at Munich, 820  
 Bagshawe (T. W.) and M. C. Lester, Wintering in the Antarctic, 50  
 Bailey and Bremer, Experimental Diabetes Inispidus, 748  
 Bailey (Dr. G. H.), Edited by Dr. W. Briggs, The Tutorial Chemistry. Part 2: Metals and Physical Chemistry. Twelfth impression (fourth edition), 663  
 Bailey (K. C.), The Direct Synthesis of Urea starting with Carbon Dioxide and Ammonia, 300  
 Baillaud (J.), The Paris Astrographic Catalogue, 160  
 Bairstow (Prof. L.), elected Chairman of the Royal Aeronautical Society, 50; S. P. Langley's Pioneer Work in Aviation, 637  
 Baker (G. A.), elected President of the Birmingham and Edgbaston Debating Society, 554  
 Baker (G. F.), gift to the American Museum of Natural History, 126  
 Baker (H. A.), Geological Investigations in the Falkland Islands, 861  
 Baker (Prof. H. B.), A Modern Text-book of Chemistry, 374  
 Baker (H. B.), *Radula* of the Helicinidae, 396  
 Baker (R. T.) and H. G. Smith, The Melaleucas and their Essential Oils. Pt. vi., 468  
 Bale (W. M.), Two new Species of Bryozoa, 563  
 Balfour (H.), Fishing and Fishing Lore, 534; The Early Metal Ages in South America, 141  
 Balfour (Sir I. Bayley), [death], 781; [obituary article], 816  
 Baly (Prof. E. C. C.), Prof. I. M. Heilbron, and D. P. Hudson, Photosynthesis of Nitrogen Compounds, 129  
 Banting (Dr.) and others, "Insulin" and the Oxidation of Sugar, 713  
 Barber (Prof. F. D.) and others, First Course in General Science, 406  
 Barcroft (J.), awarded a Royal Medal of the Royal Society, 674, 787; Physiology of Life in the Andes, 152; Physiology of Respiration, 803  
 Barger (Prof. G.), Chemistry and Medicine, 60  
 Barker (Prof. A. F.) and others, Textiles. Revised edition, 272  
 Barker (A. H.), Tests on Ranges and Cooking Appliances, 434  
 Barker (T. V.), Graphical and Tabular Methods in Crystallography as the Foundation of a New System of Practice: with a Multiple Tangent Table and a 5-Figure Table of Natural Cotangents, 629  
 Barnard (K. H.), Maps illustrating the Zoological Aspects of Wegener's Disruption Hypothesis, 332  
 Barnard (Prof. R. J. A.), Elementary Statics of Two and Three Dimensions, 243  
 Barratt (Dr. Katie), appointed Principal of the Swanley Horticultural College, 828  
 Barrington (F. J. F.), awarded the William Julius Mickle fellowship of the University of London, 720  
 Barry (Sir J. W. Wolfe), a memorial window of, in Westminster Abbey, 820  
 Barthel (Dr. C.), The Bacterial Flora of Greenland, 366  
 Barthoux (J.), Minerals of the Oudjda Region (Morocco), 332  
 Barton (Prof. E. H.), Colour Vision and Syntony, 357; The Resonance Theory of Audition, 316  
 Barton (R. F.), Social Economics in the Philippine Islands, 90  
 Bartsch (Dr. P.), Formation of Marine Deposits above Sea-level, 396  
 Barus (Prof. C.), Displacement Interferometry applied to Acoustics and to Gravitation, 7; Static Deflection, Logarithmic Decrement and First Semi-period of the Vacuum Gravitation Needle, 687  
 Bateson (Dr. W.), Interspecific Sterility, 76  
 Bathellier (J.), The Rôle of the Soldiers in *Eutermes matungensis*, 591  
 Bathier (Dr. F. A.), Black Coral, 344  
 Batson (R. G.) and J. H. Hyde, Mechanical Testing: a treatise in two volumes. Vol. i.: Testing of Materials of Construction, 804  
 Battermann (Prof. H.), [obituary article], 258  
 Bauer (Dr. L. A.) and others, Researches of the Department of Terrestrial Magnetism [Carnegie Institution]. Vol. IV.: Land Magnetic Observations, 1914-1920, 94  
 Bausch and Lomb Optical Co., Ltd., Catalogue of Microscopes and Microtomes, 363  
 Baxter (Evelyn V.) and Leonora J. Rintoul, Some Scottish Breeding Duck: Their Arrival and Dispersal, 476  
 Bayliss (L. E.), elected Michael Foster Student in Physiology in Cambridge University, 25  
 Bayliss (Sir W. M.), Internal Secretion, 658; The Cause of Rickets, 212; The Mechanism of the Cochlea, 632  
 Bazy (P. and L.), Vaccination before Operation, 167  
 Beare (Prof. T. Hudson), Railway Problems of Australia, 354  
 Beccari (Dr. O.), Annals of the Royal Botanic Garden, Calcutta. Vol. 12, Parts 2 and 3, 372  
 Becher (Prof. S.), Untersuchungen über Echtfärbung der Zellkerne mit künstlichen Beizenfarbstoffen und die Theorie des histologischen Färbeprozesses mit gelösten Lacken, 33  
 Beck (C.), The Microscope: a Simple Handbook, 147  
 Beck (Prof. R.), bearbeitet durch Dr. G. Berg, Abriss der Lehre von den Erzlagerstätten: In Anlehnung an die dritte Auflage des Lehrbuches und unter Benützung hinterlassener Aufzeichnungen, 205  
 Bedeau (M.), The Determination of the Specific Inductive Capacity of Mercury Vapour, 268  
 Beebe (W.), A Monograph of the Pheasants. In four volumes. Vol. III., 105; The Edge of the Jungle, 211  
 Béhal, Haller, and Moreau (Profs.), protective measures to prevent German chemicals entering France, 820  
 Beilby (Sir George), awarded the medal of the Institution of Mining and Metallurgy, 553  
 Belin (E.), The Transmission of Handwriting and Drawings by Wireless Telegraphy, 136  
 Bell (Dr. Alexander Graham), [obituary article], 225; the work of, F. De Land, 427  
 Bell (Prof. F. Jeffrey), Coral in Medicine, 481  
 Bell (Dr. L.), The Telescope, 627  
 Bellasis (E. S.), Hydraulics with Working Tables. Third edition, 34  
 Bellingham and Stanley, Ltd., A Differential Refractometer, 91; A Direct-reading Spectrometer, 129; A New Spectro-polarimeter, 526  
 Bemmel (Prof. J. F. van), The Dutch Zoological Society, 589  
 Benedicks (C.), The Deformability of the Photographic Layer, 723  
 Bengeough (Dr. G. D.) and J. M. Stuart, report on Corrosion and Colloids, 651  
 Benham (Prof. W. E.), Oligochaeta in the Antarctic, 823  
 Bennet (Rev. Abraham), inventor of the Gold-leaf Electro-meter, 126  
 Benson (W. N.) and S. Smith, Some Rugose Corals from the Burindi Series (Lower Carboniferous) of N.S.W., 62  
 Bent (A. C.), Life-histories of North American Gulls and Terns. Order Longipennes, 339  
 Bequaert (J.), Ants in their Diverse Relations to the Plant World, 822  
 Berg (Dr. G.), concerning the review of his work on Ore Deposits, 583  
 Berger (E.), A Formal Lamp, 28  
 Bergson (Prof. H.), Durée et Simultanéité: A propos de la théorie d'Einstein, 593  
 Bernstein (H.), the proceeds of a performance of "Judith" devoted to science, 553  
 Bernthsen (Dr. A.), new edition revised by Prof. J. J. Sudborough, A Text-book of Organic Chemistry, 602  
 Berry (C. W.), The Flora of the Dakota Series, 291  
 Berry (Dr. S. S.), Molluscs of the Colorado Desert, 887  
 Berthollet (C. L.), centenary of the death of, 611  
 Bertrand (G.), The Law of Riemann, the Perihelion of Mercury, and the Deviation of Light, 167; and Mokragatz, The Presence of Cobalt and Nickel in Arable Soil, 235; The Presence of Cobalt and Nickel in Plants, 532  
 Best (E.), The Maori Mode of Drilling, 679  
 Beveridge (H.), Perseid Meteors in July 1592, 667

- Beveridge (Sir W. H.), Periodicities, 511; and others, Weather Cycles in Relation to Agriculture and Industrial Fluctuations, 889
- Bigourdan (G.), The Observatory of Paris on the 200th Anniversary of its Construction, 895
- Bisacre (F. F. P.), Applied Calculus: An Introductory Text-book, 411
- Bjerknes (Prof.), elected an honorary member of the Royal Institution, 784
- Blackett (P. M. S.), elected Charles Kingsley Bye fellow of Magdalene College, Cambridge, 25; The Analysis of  $\alpha$ -ray Photographs, 721
- Blackman (Dr. F. F.) and others, Photosynthesis, 856
- Blackman (Prof. V. H.), Some Similarities and Dissimilarities in the Micro-biology of Plant and Animal Diseases, 293
- Blagden (J. W.) and A. Wechsler, Micro-chemical Methods in the Practical Teaching of Chemistry, 447
- Blair (E. W.) and T. S. Wheeler, The Estimation of Form- and Acet-aldehydes, 894
- Blaise (E. E.) and Mlle. Montagne, The Action of Thionyl Chloride on the  $\alpha$ -acid Alcohols, 64
- Blakely (W. F.), The Loranthaceæ of Australia. Part ii., 300; Part iii., 759
- Blanchard (Dr. Phyllis), The Care of the Adolescent Girl: a Book for Teachers, Parents, and Guardians, 411
- Blattner (Dr. E.), Lehrbuch der Elektrotechnik. Erster Teil. Vierte Auflage, 176
- Blayre (Christopher), Human Blood Relationships and Sterility, 846
- Bledisloe (Lord), Landowners and the State, 392, 501
- Blegrad (H.), Bottom-living Communities in the Sea, 887
- Bloch (Dr. L.), Le Principe de la relativité et la théorie d'Einstein, 568; and E. Bloch, Spark Spectra in Water, 27
- Blumberg (H.), New Properties of all Real Functions, 687
- Bodenstein (Prof.), invited to succeed Prof. Nernst in the Physical-Chemical Institute of Berlin University, 720
- Bohn (G.) and Dr. Anna Drzewina, La Chimie et la vie, 173
- Böhncke (Dr. G.), New Charts of the Currents of the North Sea, 885
- Bohr (Prof. N.), awarded the Nobel Prize for Physics for 1922, 674; elected a corresponding member of the Prussian Academy of Sciences, Berlin, 158
- Boiry (F.), Vulcanising Rubber in Solution, 235
- Bonacina (L. C. W.), A Rainbow Peculiarity, 160
- Bond (Dr. C. J.), Sex of Irish Yew Trees, 810
- Bone (Mrs. W. A.), [obituary], 225
- Bonnier (M.), The Estimation of Alkaline Carbonates in Presence of Phenolphthalein, 723
- Booth (E. H.), The Photographic Work of the Sydney University Eclipse Expedition, Goondiwindi, Queensland, 896
- Booth (H.), Aeroplane Performance Calculations, 110
- Bordet (Prof.), conferment upon, of an honorary doctorate by Paris University, 754
- Boscovich (R. J.), A Theory of Natural Philosophy. Latin-English edition, 870
- Bostwick (J. A.), gift by, to Wake Forest College School of Medicine, 166
- Boswell (Prof. P. G. H.), The Petrography of the Cretaceous and Tertiary Outliers of the West of England, 62
- Bouchet (L.), An Absolute Plane-cylinder Electrometer, 831
- Boulanger (Ch.) and G. Urbain, The Composition and Chemical Characters of Thortveitite from Madagascar, 27
- Boulenger (E. G.), The Zoological Society, 314
- Boulenger (Dr. G. A.), Monograph of the Lacertidae; Vol. II., 410
- Bouty (Prof. E.), [obituary], 883
- Bouvier (Prof. E. L.), translated by Dr. L. O. Howard, The Psychic Life of Insects, 402
- Bower (Prof. F. O.), elected President of the Royal Society of Edinburgh, 612
- Bower (W. R.) and Prof. J. Satterly, Practical Physics. Eighth Impression (second edition), 445
- Bowie (E. H.), Anomalous Storm Tracks, 429; West Indian Hurricanes, 614
- Bowley (Prof. A. L.), The Need of an Interpreter for Science, 320
- Bowring (H. I.), conferment upon, of an honorary degree by Leeds University, 561
- Boycott (Prof. A. E.), Histological Stains, 114; The Smoke of Cities, 413
- Braecke (Mlle. Marie), The Presence of Aucubine and of Melampyrite (Dulcite) in several Species of Melampyrum, 831
- Brachet (Prof. A.), The Properties of the Germinal Localisations of the Egg, 622; Traité d'embryologie des vertébrés, 275
- Bradbrooks (W.) and Prof. F. G. Parsons, Anthropology in the Chiltern Hills, 526
- Brady (F. L.), The Structure of Eutectics, 531
- Bragg (Sir William H.), elected a corresponding member of the Paris Academy of Sciences, 820; The Structure of Organic Crystals, 115
- Bragg (Prof. W. L.) and R. W. James, The Intensity of X-ray Reflection, 148
- Brammall (A.) and H. F. Harwood, The Dartmoor Granite: its Accessory Minerals and Petrology, 99
- Brearely (H.), The Case-hardening of Steel: an Illustrated Exposition of the Changes in Structure and Properties induced in Steels by Cementation and Allied Processes. Second edition, 537
- Breit (G.), Radio Direction-finding in Flying Machines, 59, 188; Skin Effect in Solenoids, 668
- Brepson (Mlle. F.), The Rôle of the Phenomena of Solifluxion in the Model of the Region of Saulieu (Morvan), 686
- Bridel (M.) and Mlle. Marie Braecke, Rhinanthine and Aucubine, 655; The Presence of Aucubine and of Saccharose in the Seeds of *Rhinanthus Crista-Galli*, 623; and C. Charaux, Centaureine, a New Glucoside, extracted from the Roots of *Centaurea jacea*, 759, 895
- Brierley (S. S.), An Introduction to Psychology, 872
- Bright (Sir Charles), Pioneer Work in Submarine Cable Telegraphy, 195
- Brioux (Ch.), The Comparative Assimilability of Calcium Phosphate and the Phosphates of Iron and Alumina, 864
- British Drug Houses, Ltd., Catalogue of Chemical Products, 653
- Broadbent (B.), conferment upon, of an honorary degree by Leeds University, 561
- Brochet (A.), The Preparation of Active Nickel for Organic Catalysis, 759; The Preparation of Cyclohexanol, 623
- Brodetsky (Dr. S.), Laplace's Essai philosophique sur les probabilités, 6; Motorless or Wind Flight, 483; Statics, Dynamics, and Hydrodynamics, 243; The Line of Action of the Resultant Pressure in Discontinuous Fluid Motion, 794
- de Broglie (Duc), X-ray Electrons, 681
- de Broglie (L.) and A. Dauvillier, Analogies of Structure between the Optical Series and Röntgen Series of Lines, 723; The Spectral System of the X-rays, 686
- Bromehead (C. E. M.), The Site and Growth of London, 494
- Brooks (C. E. P.), Spell of Warm Winters in Europe, 557; and J. Glasspoole, The Drought of 1921, 55
- Brooks (Prof. C. F.), Local or Heat Thunderstorms, 615
- Brooks (E. E.), Polarisation of Diffused Light under the Sea, 114
- Brooks (F. T.), Some Present-day Aspects of Mycology, 563
- Brooks (H. Jamyn), Universal Problems, 804
- Brooks (S.), A British Oil Victory, 401
- Brown (Prof. A. Crum), [death], 610; [obituary article], 673
- Brown (A. R.), The Andaman Islanders: a Study in Social Anthropology, 106; the review of "The Andaman Islanders," 554
- Brown (E. O. Forster), Underground Waters in the Kent Coalfield and their Incidence in Mining Development, 822
- Brown (Prof. F. D.), [obituary article], 490
- Brown (Dr. R. N. Rudmose), O. J. R. Howarth, and J. Macfarlane, The Scope of School Geography, 245
- Browne (Rev. H. C.), Einstein's Paradox, 668
- Browning (Prof. K. C.), German Book Prices, 845
- Bruce (Sir David), awarded the Buchanan Medal of the Royal Society, 674, 787

- Brunhes (J.) and C. Vallaux, La Géographie de l'histoire : Géographie de la paix et de la guerre sur terre et sur mer, 175
- Brunschvicg (Prof. L.), L'Expérience humaine et la causalité physique, 471
- Brunt (Dr. D.), Waterspouts, 414
- Bryant (C. L.), Science Primers, 406
- Bryant (F. B.), [obituary article], 882
- Bryant (Dr. Sophie), [death], 361; [obituary article], 458
- Buchanan (A.), Exploration of Air: Out of the World North of Nigeria, 35
- Buchanan (Miss M. M.), Attack on a Moth by a Wasp, 323
- Buckman (S. S.), Critical Research on Fossil Brachiopoda, 262
- Budge (Sir E. Wallis), The Discoveries of Lord Carnarvon and H. Carter in Egypt, 783
- Buller (Prof. A. H. R.), Luminescence in *Panus stypticus*, 563
- Bulloch (Prof. W.), The Influence of Pasteur on the Development of Bacteriology and the Doctrines of Infection and Immunity. Supplement (December 23), vi.
- Bunting (Martha), Preliminary Note on Tetramitus, a Stage in the Life Cycle of a Coprozoic Amoeba, 687
- Burkill (J. C.), elected a fellow of Trinity College, Cambridge, 561
- Burr (Prof. W.), Rural Organization, 404
- Burton (W.), King's Chelsea Porcelain, 871
- Burtt-Davy (Dr. J.), A Revision of the South African Species of *Dianthus*, 27
- Bury (Lt.-Col. C. K. Howard) and others, Mount Everest: The Reconnaissance, 1921, 139
- Butler (C. P.), The Systematic Distribution of Solar Calcium Flocculi, 20
- Butler (E. J.), Virus Diseases in Plants, 622
- C. (C.), A Relativity Paradox, 844
- Cabannes (J.), The Polarisation and Intensity of the Light diffused by Transparent Liquids, 795
- Cabaud (R.), Installations électriques industrielles: choix du matériel, 474
- Cabot (E. L.), Seven Ages of Childhood, 872
- Cadness (H.), appointed Special Lecturer in Textile Design in Manchester University, 653
- Cajal (Prof. S. Ramón y), retirement of, 492
- Cambage (R. H.), Acacia Seedlings. Pt. viii., 592
- Cambier (R.) and E. Aubel, Culture of Bacteria in a Medium of Definite Chemical Composition, with Pyruvic Acid as a Base, 200
- Cameron (Dr. A. E.), The Structure and Biology of *Simulium simile*, 396
- Cameron (H. S.), Volcanic Activity in Nigeria, 497
- Campbell (D.), In the Heart of Bantuland, 246
- Campbell (Dr. D.), Galen's work on Anatomical Administration, 296
- Campbell (Dr. N. R.), Modern Electrical Theory. Supplementary Chapters. Chapter XV.: Series Spectra, 767; The Dimensions of Area, 9; What is Science? 728
- Cannon (H. G.), Surface Tension and Cell-division, 181
- Cannon (W. A.), Plant Habits and Habitats in the Arid Portions of South Australia, 365
- Cano (Juan Sebastian del), fourth centenary of the circumnavigation of the world by, 426
- Capen (Dr. S. P.), installed as Chancellor of the University of Buffalo, 793
- Capparoni (Dr.), "Magistri Salernitani nondum cogniti," 296
- Capstick (Dr. J. W.), Sound: an Elementary Text-book for Schools and Colleges. Second edition, 510
- Carey (Prof. F.), impending retirement of, from Liverpool University, 751
- Carey (G. V.), appointed Educational Secretary to the Cambridge University Press, 530
- Carnarvon (Lord) and H. Carter, Excavations in Egypt, 783
- Carnot (P.) and M. Tiffeneau, A New Hypnotic in the Barbituric Series: Butyl-ethyl-malonylurea, 299
- Carpenter (Dr. G. D. Hale), Waterspouts, 414
- Carpenter (Prof. G. H.) and Miss K. C. J. Phillips, The Collembola of Spitsbergen and Bear Island, 100
- Carpenter (Miss K.), Lead and Animal Life, 543
- Carr (Prof. H. Wildon), Bergson and Einstein, 503; Dialectic, 208; Einstein's Paradox, 660; The New Way of Thinking Physical Reality, 471
- Carrere (L.), The Sphincter of the Iris in the Selacians, 468
- Carroll (J. A.), elected a Fellow of Sidney Sussex College, Cambridge, 25
- Carlsaw (Prof. H. S.), Advanced Mathematical Study and Research at Cambridge, 8
- Carter (F. W.), Railway Electric Traction, 338
- Casanowicz (I. M.), Religious Ceremonial of the Parsis, 161
- Castiglioni (Prof.), Art in the Italian Pharmacy of the 15th Century; Dante and Averrhoism, 296
- Castle (W. E.), Genetic Studies of Rabbits and Rats, 463
- Cathcart (Prof. E. P.), Basal Metabolism, 204; The Efficiency of Man and the Factors which Influence it, 354, 453
- Cator (G.), The One and the Many, 804
- Caulery (Prof. M.), translated by J. H. Woods and E. Russell, Universities and Scientific Life in the United States 72
- Cave (Capt. C. J. P.), The Green Ray at Sunset and Sunrise, 604; Winter Thunderstorms, 877
- Cawston (F. G.), South African Larval Trematodes and the Intermediary Hosts, 832
- Cesáro (C.), The Blue Crystals of Disthene found at Katango, 864
- Chadwick (Dr. J.), Radioactivity and Radioactive Substances, 412
- Chamberlain (Prof. J. S.), A Text-book of Organic Chemistry, 805
- Chambers (C. D.), Fewness of Dovecots in the Roman Period, 748
- Chambers (R.), New Apparatus and Methods for the Dissection and Injection of Living Cells, 722
- Chapman (A. Chaston), The Use of the Microscope in the Brewing Industry, 99
- Chapman (F.), New or Little-known Victorian Fossils in the National Museum. Pt. xxvi., 168
- Chapman (Prof. H. H.), Forest Mensuration, 407
- Charcot (Dr. J. B.) and A. Lacroix, The Structure of Rockall, 90
- Chatterji (K. P.), elected to the Anthony Wilkin studentship in Cambridge University, 828
- Chattock (Prof. A. P.) and L. F. Bates, The Richardson Gyro-magnetic effect, 721
- Chaudron (G.) and L. Blanc, The Estimation of Oxygen in Steel, 795
- Chautard (J.), Les Gisements de pétrole, 474
- Chauveau (B.), Électricité atmosphérique. Premier Fasc.: Introduction historique, 406
- Cheel (E.), *Melaleuca linariifolia* and *Melaleuca trichostachya*, 236; The Species of *Darwinia Hamoranthus*, and *Kylstonea* in the States of N.S.W., Victoria, South Australia, and Queensland, 236
- Cheshire (Prof. F.), Rotary Polarisation of Light, 807
- Chevenard (P.), Nickel Alloys retaining their Rigidity over an Extended Temperature Range, 592
- Chick (Dr.) and others, The Cause of Rickets, 137
- Child (C. H.), appointed an Honorary Clinical Tutor in Dental Surgery in Leeds University, 621
- Chipp (Major T. F.), appointed Assistant Director of the Royal Botanic Gardens, Kew, 189
- Chittenden (Dr. R. H.), retirement from the directorship of the Sheffield Scientific School, Yale University, 60
- Chopard (M.), Orthoptera and Dermaptera of France, 822
- Chree (Dr. C.), The Magnetic Work of the Carnegie Institution, 94
- Church (Major A. G.), Science and the Empire, 876
- Cisaf (J.) and F. Pokorný, The Czechoslovak Republic, 839
- Cisotti (Prof. U.), Idromeccanica Piana. Parte Prima and Parte Seconda, 243
- City Sale and Exchange, Catalogue of Koristka Microscopes and Accessories, 52
- Clapham (C. B.), Metric System for Engineers, 340
- Claridge (G. C.), Wild Bush Tribes of Tropical Africa, 340
- Clark (C. H. D.), A Sliding Scale for the Convenient Titration of Strong Liquids by Dilution and Use with Aliquot Parts, 894
- Clark (J. E.), H. B. Adams, and I. D. Margary, Report on Phenological Observations for the year 1921, 27

- Clark (J. McClare), The Effect of Post-war Conditions on Agriculture, 743
- Clarke (A.), Coal-tar Colours in the Decorative Industries, 768
- Clarke (Dr. Lilian J.), The Botany Gardens of the James Allen's Girls' School, Dulwich, 329, 512
- Clarke (W. G.), Our Homeland Prehistoric Antiquities, and how to study them, 510
- Claxton (T. F.), Report of the Royal Observatory, Hong-Kong, 1921, 220
- Clay (Dr. R. S.), The Photographic Lens from the Historical Point of View, 675, 739
- Cleland (Prof. J. B.), A Second Bird Census, 236; Ball Lightning, 40
- Clements (F. E.), Aeration and Air Content: the Role of Oxygen in Root Activity, 58
- Clemesha (Lt.-Col.), Methods of Collection and Disposal of Excreta suitable for Small Tropical Villages, 232
- Clelland (J. E.), The Oxide Method of determining Aluminium, 499
- Clerk (Sir Dugald), conferment upon, of an honorary degree by Leeds University, 561; presented with the Albert Medal of the Royal Society of Arts, 50
- Cluzet (J.) and A. Chevallier, The Radioactivity of the Springs of Echaillon, 895
- Cobb (Prof. J. W.), Fuel in Relation to Health, 232; Low Temperature Carbonisation, 718; Report of the Department of Coal Gas and Fuel Industries (with Metallurgy) of Leeds University, 26; The Thermal Basis of Gas Supply, 671
- Coblentz (Dr. W. W.), Stellar Temperatures and Planetary Radiation, 886; Tests of Stellar Radiometers, etc., 367
- Cochrane (J. A.), Readable School Physics, 340
- Cockerell (Prof. T. D. A.), An Ancient Wasp, 313; *Rudbeckia* and *Aquilegia*, 278; and Dorothy Young, A Mutation of the Columbine, 701
- Codrington (Dr. R. H.), [obituary article], 425
- Cohen (Prof. J. B.), The New Smoke Abatement Bill, 269; The Smoke of Cities, 414
- Coker (Prof. E. G.), The Action of Cutting Tools, 118, 700; presented with the Howard N. Potts gold medal of the Franklin Institute, 288; Recent Photo-elastic Researches on Engineering Problems, 41
- Cole (Prof. G. A. J.), Rocks and their Origins. Second edition, 768; The Oldest known Rocks of the Earth's Crust, 39; The Primitive Crust of the Earth, 249; The Reopening of Europe, 599; Volcanic Shower in the N. Atlantic, 635; Water Underground, 242; Wegener's Drifting Continents, 798
- Collett (A.), The Changing Year, 410
- Collingwood (R. G.), Prof. A. E. Taylor, and Dr. F. C. S. Schiller, Are History and Science different Kinds of Knowledge? 231
- Collins (H. F.), Some Crystallised Sulphates from the Province of Huelva, Spain, 100
- Collins (S. H.) and B. Thomas, The Sugars and Albuminoids of Oat Straw, 887
- Colwell (Dr. H. A.), An Essay on the History of Electro-therapy and Diagnosis, 32
- Coman (S.), bequest to Chicago University, 166
- Combes (R.) and Mlle. Denise Kohler, The Disappearance of Hydrocarbons in Dying Leaves, 623; The Role of Respiration in the Diminution of the Carbohydrates in Leaves during the Autumnal Yellowing, 468
- Compton (Prof. A. H.) and N. L. Freeman, The Intensity of X-ray Reflection from Powdered Crystals, 38
- Comstock (Prof. G. C.), Observations of Double Stars, 1907-1919, 7
- Constantin, Joessel, and Daloz, A Boat which moves against the Wind, using the Wind itself as Motive Power, 686
- Conway (Sir Martin), appointed to the Board of Trustees of the National Portrait Gallery, 394
- Cook (H. D.) and Dr. A. H. Gibson, Hydro-electric Engineering. Vol. i.: Civil and Mechanical, 108
- Cook (M.), The Antimony-bismuth system, 531
- Cooke, jr. (C. M.), Hawaiian Zonitidae and Succineidae, 365
- Cooke and Sons, Ltd. (T.), list of Surveying Instruments, 324
- Cooper (Dr. E. Ashley), appointed Lecturer in Public Health Chemistry, 684
- Cooper (P. A.), The X-ray Structure of Potassium Cyanide, 544
- Cooper (W. R.), appointed Editor of *Science Abstracts*, 493; The Electrochemical Effects produced by superimposing Alternating Currents upon Direct Currents, 135
- Cornish (Dr. Vaughan), The Isothermal Frontier of Ancient Cities, 558
- Cornthwaite (H. G.), Climate and Photography, 429
- Corrêa (Prof. A. A. M.), *Homo (Os Modernos Estudos sobre a Origem do Homem)*, 510
- Cortie (Rev. A. L.), The Influence of Science, 180, 378
- Costantin (J.), Acquired Heredity, 167
- Costerus (Dr. J. C.), Median Proliferation of Flowers of *Heimerocallis*, 494
- Cousen (A.), Selenium in the Production of Colourless Glass, 830
- Coward (T. A.), Manchester Birds, 1822-1922, 563
- Crabtree (J. H.), Rocks and Fossils and How to Identify Them, 74
- Craig (E. H. Cunningham), Carbonaceous Material in Oil-shale, 55
- Crawford (O. G. S.), Harpoons under Peat at Holderness, Yorks, 481; Long Barrows in the Cotswolds and Welsh Marches, 585
- Crehore (Prof. A. C.), The Hydrogen Molecule, 587
- Crewe (Marquess of), acceptance of the Presidency of the British Science Guild, 611
- Crommelin (Dr. A. C. D.), Lt.-Col. G. L. Tupman, 742; Prof. J. C. Kapteyn, 48; The Origin of Worlds, 660; The reported Nova in Lyra, 821; The Total Solar Eclipse of September 21, 389, 457; W. H. Wesley, 609
- Crommelin (Dr. C. A.) and others, Generation and Utilisation of Cold, 618
- Cronshaw (Dr. H. B.), Oil Shales, 307; Silver Ores, 477
- Crook (C. W.), elected to the Senate of London University, 562
- Crook (T.), The Earth's "Crust" and its Composition, 253
- Crowther (Prof. C.), appointed Principal of the Harper-Adams Agricultural College, 399
- Crowther (Dr. J. A.), Ions, Electrons, and Ionising Radiations. Third edition, 340; The Principles of Radiography, 35
- Cucnot (L.) and L. Mercier, The Loss of the Faculty of Flight in Parasitic Diptera, 532; and R. Poisson, The Development of some Coaptations of Insects, 591
- Cummer (Prof. C. L.), A Manual of Clinical Laboratory Methods, 731
- Cunningham (Dr. Brysson), Empire Water-power, 767; Reservoir and other Dams, 661
- Cunningham (E.), Prof. Eddington's Romanes Lecture, 568; The Measurement of Intervals, 698
- Cunningham (J. T.), Medical Education, 846
- Curie (Mlle. Irène), The Determination of the Velocity of  $\alpha$ -rays of Polonium, 299
- Curie (M.), The Refractive Indices of the Phosphorescent Sulphides, 655
- Curtis (Dr. H. D.), Absolute Magnitudes of Stars, 395
- Cushman (J. A.), Foraminifera of the Atlantic Ocean, 365; Philippine Foraminifera, 261
- Cutler (D. W.), L. M. Crump, and H. Sandon, A Quantitative Investigation of the Bacterial and Protozoan Population of the Soil, 26
- Dakin (A.), Practical Mathematics. Part 1, 375
- Dakin (Prof. W. J.), Medical Education, 845
- Dalby (Prof. W. E.), The Internal Combustion Engine, 122
- Dalton (Prof. J. P.), The Mathematics of the Homogeneous Balanced Action, 468
- Damiens (A.), The Absorption of Ethylene by Sulphuric Acid, 623; The Crystallisation of Amorphous Tellurium, 63
- Dana (Prof. E. S.), Third edition, revised and enlarged by Prof. W. E. Ford, A Text-book of Mineralogy; with an extended Treatise on Crystallography and Physical Mineralogy, 210
- Dangard (L.), The Geological Study of the Bottom of the English Channel, 895

- Dangeard (P. A.), The Structure of the Cell in the Iris, 167, 200
- Danois (F. Le), The Prediction of the Value of the Herring Catch in Winter, 864
- Danysz-Michel (Mme.) and W. Koskowski, Some Digestive Functions in Normal Pigeons, fed with Polished Rice or kept without Food, 200
- Dart (Dr. R. A.), appointed Professor of Anatomy in the University of Witwatersrand, 720
- Darwin (C. G.), appointed Tait Professor of Natural Philosophy in Edinburgh University, 720; A Quantum Theory of Optical Dispersion, 841
- Datta (S.), An Exception to the Principle of Selection in Spectra, 39; The Absorption Spectrum of Potassium Vapour, 655
- Daval (M.), Construction des réseaux d'énergie, 731
- Davenport (C. B.), Inheritance of Stature, 463
- David (Dr. W. T.), appointed Professor of Civil and Mechanical Engineering in Leeds University, 25
- Davidge (H. T.) and R. W. Hutchinson, Technical Electricity. Fourth edition, 840
- Davidson (Mr.), Skjellerup's Comet, 89
- Davies (Dr. A. Morley), Bloomsbury, 250
- Davis (R.) and F. M. Walters, jr., Sensitometry of Photographic Emulsions, etc., 430
- Davis (Prof. W. M.), Coral Reefs of the Louisiade Archipelago, 56
- Dawkins (Prof. R. M.), elected to an honorary fellowship at Emmanuel College, Cambridge, 590
- Dean (Prof. H. R.), appointed Professor of Pathology in Cambridge University, 368; elected to a professional fellowship at Trinity Hall, Cambridge, 590
- Deb (H. K.), The Swastika, Gammadion, Fylfot, 365; The Origin of the Swastika Symbol, 228
- Deecke (Prof. W.), Phytopaläontologie und Geologie, 375
- Deeley (R. M.), Capillarity, 543; Density of Adsorbed Films, 313
- Deerr (N.), Cane Sugar: A Text-book on the Agriculture of the Sugar Cane. The Manufacture of Cane Sugar, and the Analysis of Sugar-house Products. Second edition, 4
- Defant (A.), Turbulence on a Large Scale, 495
- Degen (E.), [obituary], 883
- Dequide (C.) and P. Baud, Recovery of Sugar from Beet Molasses, 22
- Déjardin (G.), The Production of the Spectrum of Mercury, 831
- Delaby (R.), The Alkyl-glycerols, 895
- Delambre (J. B. J.), centenary of the death of, 259
- De Land (F.), the work of Dr. A. Graham Bell, 427, 746
- Delury (Prof. A. T.), appointed Dean of the Faculty of Arts of Toronto University, 684
- Demolon (A.), The Accessory Elements in Thomas Slag, 168
- Denbigh (Earl of), The Rat and its Repression, 278
- Denning (W. F.), Large Fireballs, 821; Large Meteor on October 17, 645; Recent Meteors, 613; The Leonid Meteor Shower, 712
- Densmore (Miss Frances), Music of the Ute Indians, 646
- D'Erasmio (Prof. G.), Fossil Fish from Southern Italy, 190
- Dervin and Olmer, Ammoniacal Silver Fluoride, 863
- Desch (Prof. C. H.), Metallography. Third edition, 305; The Metallurgical Chemist, 710; The Metallurgy of Iron and Steel, 537; The Nitrogen Industry, 670
- Desgrez (A.), H. Bierry, and F. Rathery, Diabetes,  $\beta$ -oxybutyric Acid, and Levulose, 623
- Deslandres (Dr. H.), Emission of Cathode and X-rays by Celestial Bodies, 847; The Emission of X-rays, Ultra X-rays, and Corpuscular Rays by the Celestial Bodies, 622; and V. Burson, The Atmospheres of the Stars, 268
- Devanesan (D. W.), The Development of the Calcareous Parts of the Lantern of Aristotle in *Echinus miliaris*, 26
- Dibble (S. E.), Plumbers' Handbook, 602
- Dickenson (J. H.), The Flow of Steels at a Low Red Heat, 776
- Dienert (F.) and P. Etrillard, The Possibility of the Existence of Organisms in Rocks capable of Reviving after Sterilisation by Heat, 591
- Dillon (Dr. T.), Dr. Rosalind Clarke, and V. M. Hinchey, A Chemical Method of separating the Isotopes of Lead, 167, 439
- Dines (J. S.), The Effect of a Coast Line on Precipitation, 235
- Dines (W. H.), retirement of, from the directorship of the Aerological Observatory at Benson, 188; The Cause of Anticyclones, 845
- Dingle (H.), The Deflection of Light in a Gravitational Field, 389
- Ditshisheim (P.), A New Balance for compensating the Temperature Error of Watches and Chronometers, 830
- Dix (Rev. G. H.), the degree of D.Lit. conferred upon, by London University, 860
- Dixey (F.), The Geology of Sierra Leone, 757
- Dixon (Prof. H. B.), the impending retirement of, from the chair of Chemistry in Manchester University, 621
- Dixon (Prof. H. H.), Practical Plant Biology: A Course of Elementary Lectures on the General Morphology and Physiology of Plants, 274; Transport of Organic Substances in Plants, 355, 547
- Dodd (S.), Poisoning of Sheep by *Solanum cinereum*, 592
- Dodgson (R. W.), Noctiluca as an Enemy of the Oyster, 343
- Doherty (W. M.), The Food Value of the Snapper (*Pagrosomus auratus*), 896
- Donders (F. C.), Reden gehalten bei der Enthüllung seines Denkmals in Utrecht, am 22. Juni 1921, Prof. C. A. Pekelharing, and others, 147
- Doublet (E.), Histoire de l'astronomie, 600
- Douglas (C. K. M.), Observations of Upper Cloud Drift as an Aid to Research and to Weather Forecasting, 235
- Dover (A. T.), Industrial Motor Control: Direct Current, 805
- Downing (E. R.), A Naturalist in the Great Lakes Region, 444
- Downs (Dr. C. R.) and J. M. Weiss, awarded the Howard N. Potts Medal of the Franklin Institute, 643
- Drew (Dr.), The Growth of Normal and Malignant Tissues *in vitro*, 266
- Drew (Dr. C.) and Dr. Mottram, Vitamin Deficiencies, 266
- Dreyer (Dr. J. L. E.), Flamsteed's Letters to Richard Towneley, 525
- Druce (J. G. F.) and A. Glazunov, Transcription of Russian Names, 512
- Drummond (Dr. J. C.), appointed Professor of Biochemistry at University College, London, 165; and Watson, Testing for Vitamins, 557; and others, Vitamins, 652
- Drummond (Dr. W. B.), The Miraculous Draught of Fishes, 666
- Dubois (E.), The Minimum Potential of Electric Discharge in Gases at Low Pressures, 831
- Dubois (R.), The Destruction of Mosquitoes by Eels, 468
- Dubrisay (R.), The Action of Boric Acid on Mannite in Alkaline Solution, 723
- Dudgeon (G. C.), The Agricultural and Forest Products of British West Africa. Second edition, 210
- Duerden (Dr. J. E.), Problems of Race and Nationality in South Africa, 21
- Duff (Prof. A. W.), The Teaching of Physics to Engineering Students, 792
- Duffieux (M.), The Mass of the Particles which give the Spectrum of Carbon Monoxide, 268
- Dumas (J.), D. Combiesco, and J. Baltiano, The Action of the Tetanic and Diptheric Toxins administered by the Mouth, 724
- Duncan (J.), An Introduction to Engineering Drawing, 476
- Dunk (J. L.), Hyperacoustics. Division II.: Successive Tonality, 411
- Dunkerly (J. S.), Medical Education, 846
- Dunn (Prof. J. S.), appointed Procter Professor of Pathology and Pathological Anatomy in Manchester University, 133
- Durand (Jean), The Thermal Modifications of some Cast Irons, 623
- Durham (Earl of), elected President of the University of Durham Philosophical Society, 784
- Dwerryhouse (Dr. A. R.), The Glaciation of the Counties of Antrim, etc., 167
- Dyson (Sir Frank), conferment upon, of an honorary degree by Leeds University, 561; speech at the unveiling of a portrait medallion of Sir Norman Lockyer, 192

- Earland (A.), Extraction of Radiolaria from Oozes, 216  
 Eastman Kodak Coy., List of Organic Chemicals. New edition, 653  
 Eblé (L.), Magnetic Measurements in the Paris Basin, 592  
 Eddington (Prof. A. S.), A Relativity Paradox, 844; Ouvrage traduit de l'anglais, par J. Rossignol, Espace, Temps et Gravitation: La théorie de la relativité généralisée dans ses grandes lignes, 410; The Measurement of Intervals, 697; The Propagation of Gravitational Waves, 727; The Romanes Lecture, 1922: The Theory of Relativity and its Influence on Scientific Thought, 568  
 Edgeworth (Prof. F. Y.), Equal Pay for Equal Work, 533  
 Edman (I.), Human Traits and their Social Significance, 146  
 Edridge-Green (Dr. F. W.), Colour Vision and Syntony, 513; The Movement of the Positive After-image, 772  
 Edwards (D. L.), Spectroscopic Parallaxes of B Stars, 886  
 Edwards (F. W.), *Plasiosciara perniciosa*, 396  
 Edwards (R. E.), appointed Demonstrator in Agricultural Botany in Leeds University, 621  
 Edwards (W. C.), Roman Remains in London, 556  
 Effront (J.), The Absorption of Pepsin and Hydrochloric Acid by Foods, 758  
 Egerton (A. C.), Separation of the Isotopes of Zinc, 773  
 Ehrenfest (Prof.), elected an honorary member of the Royal Institution, 784  
 Eichhorn (Dr. G.), Drahtloser Übersee-Verkehr, 374  
 Eikenberry (Prof. W. L.), The Teaching of General Science, 731  
 Einstein (Prof. A.), awarded the Nobel Prize for Physics for 1921, 674; and Prof. H. Minkowski, translated by M. N. Saha and S. N. Bose, The Principle of Relativity, 275  
 Eldridge (J. A.), Energy Losses accompanying Ionisation and Resonance in Mercury Vapour, 563  
 Elles (Dr. Gertrude), The Graptolite Faunas of the British Isles, 262  
 Elmhirst (R.), Habits of *Echinus esculentus*, 667  
 Elwell, Ltd. (C. F.), Wireless Telephony Receiving Sets, 127  
 Elves (H. J.), [obituary article], 780  
 Emmons (Prof. W. H.), General Economic Geology: a Text-book, 210  
 Eno (A. F.), bequest to Columbia University, 26  
 Enos (C. L.), Identification of Cows by Pattern Prints, 646  
 Erdman (Dr. H. E.), The Marketing of Whole Milk, 570  
 Eredia (Prof. F.), Mount Etna and Upper Air Currents, 291; Rainfall in Southern Italy and Tripoli, 60  
 Ernie (Lord), English Farming: Past and Present. Third edition, 204  
 Evans (Sir Arthur), New Discoveries at Knossos, 125  
 Evans (Prof. C. Lovatt), Mustard Gas Poisoning, 32  
 Evans (E. A.), Lubricating and Allied Oils, 75  
 Evans (E. J.), Building Contracts: The Principles and Practice of their Administration, 110  
 Evans (H. M.), The Defensive Spines of Fishes, etc., 26  
 Evans (Dr. I. B. Pole) and Mary Pole Evans, Rise in Temperature of Living Plant Tissue when infected by Parasitic Fungus, 480  
 Evans (I. H.), Among Primitive Peoples in Borneo: a Description of the Lives, Habits and Customs of the Piratical Head-hunters of North Borneo, 146  
 Evans (L.), Exhibition of Historical Scientific Instruments at Oxford, 783; offer to Oxford University of a collection of early scientific instruments, 828  
 Everet (Miss Alice), Unit Surfaces of Cooke and Tessar Photographic Lenses, 829  
 Evers (N.) and H. J. Foster, The Sulphuric Acid Test for Fish Liver Oils, 894  
 Evershed (J.), Optical Definition and Resolving Power, 179; Spectroscopic Parallaxes for Type A, 584  
 Evershed and Vignoles, Ltd., The "Meg" Insulation Tester, 586  
 Ewing (Sir J. A.), The Atomic Process in Magnetisation: further notes, 862; and others, The New Magnetic Atom and its Properties, 162  
 Fabellein (M.), The Hydrogenation of Aldehydes and Ketones in the Presence of Pure and Impure Platinum Black, 863  
 Fairbourne (A.), Gas Pressures and the Second Law of Thermodynamics, 113  
 Fallaize (E. N.), The Piltdown Skull, 161  
 Fantham (Prof. H. B.), Some Protozoa found in Soils in South Africa, 831  
 Farmer (Prof. J. B.), The West Indian College of Tropical Agriculture, 775  
 Farmer (Dr. R. C.), appointed Deputy Director of Explosives Research at the War Office Research Department, 460  
 Favé (L.), [obituary article], 361  
 Fawsitt (C. E.) and C. H. Fischer, The Miscibility Test for Eucalyptus Oils, 468  
 Fenton (Dr. H. J. H.), Notes on Qualitative Analysis: Concise and Explanatory. Supplement, 840  
 Ferens (I. R.), presentation of a site for advanced technical departments at Hull, 530  
 Ferguson (D.) and others, Geology of Antarctic Lands, 96  
 Ferguson (E. W.) and G. F. Hill, Australian Tabanidae. Part II., 500  
 Fernald (Prof. H. T.), Applied Entomology: an Introductory Text-book of Insects in their Relations to Man, 35  
 Fewkes (Dr. J. W.), Pipe Shrine House, 819  
 Field (G. C.), Dr. F. Aveling, and Prof. J. Laird, Is the Unconscious Conception of Value in Psychology? 231  
 Findlay (Dr. L.), The Cause of Rickets, 137; and Prof. Mellanby, Etiology of Rickets, 294  
 Firth (Violet M.), The Machinery of the Mind, 146  
 Fischer (E.), Untersuchungen über Kohlenhydrate und Fermente II. (1908-1919). Herausgegeben von M. Bergmann, 142  
 Fischer (Prof. M. H.) and others, Soaps and Proteins: Their Colloid Chemistry in Theory and Practice, 70  
 Fishenden (Dr. Margaret W.), The Efficiency of Low Temperature Coke in Domestic Appliances, 434  
 Fisher (Dr. K.), appointed Headmaster of Oundle School, 330  
 Fisher (R. A.), Problems of Mendelian Ratios, 786; The Dominance Ratio, 100  
 Fisher (Dr. W. J.), Waterspouts, 669  
 Flattely (F. W.) and C. L. Walton, The Biology of the Seashore, 540  
 Fleming (A.) and V. D. Allison, Further Observations on a Bacteriolytic Element found in Tissues and Secretions, 686  
 Fleming (A. P. M.), Broadcasting in America, 294; Radiotelephony and Broadcasting, 858; Wireless Telephony, 852  
 Fleming (Dr. J. A.), elected an honorary member of the Institution of Electrical Engineers, 745  
 Fletcher (C.) and H. McLean, The Link between the Practitioner and the Laboratory: a Guide to the Practitioner in his Relations with the Pathological Laboratory, 376  
 Fletcher (Sir Walter), Medical Research and the Nation, 50  
 Fleure (Prof. H. J.), The Peoples of Europe, 768  
 Fleury (P.), An Electrical Furnace with Molybdenum Resistance *in vacuo*, 795  
 Florence (Miss L.), The Structure and Biology of the Hog Louse, 396  
 Flynn (Prof. T. T.), Occurrence of the Rare Whale, *Mesoplodon Layardi*, on the Tasmanian Coast, 379  
 Ford (Prof. W. E.), appointed Curator of Mineralogy in the Peabody Museum of Natural History, 675  
 Ford (W. K.), Capture of a Large Common Viper in Epping Forest, 461  
 Forster (Dr. M. O.), appointed Director of the Indian Institute of Science, Bangalore, 258  
 Forsyth (Prof. A. R.), Differential Invariants and other Concomitants of Quadratic Differential Forms in Four Variables, 27  
 Forsyth (Dr. D.), The Technique of Psycho-analysis, 246  
 Foster (Sir Gregory), The University of London (History, Present Resources and Future Possibilities), 240  
 Fountain (Dr. E. O.), Roche's Limit for Satellites, 89; The Colour of the Martian Deserts, 364  
 Fourneau (Prof. E.), Préparation des médicaments organiques, 69

- Fournier (E.), The Guidance of Dirigible Balloons through Fog by the Method of W. A. Loth, 863; The Nature and Structure of the Substratum of the Jura Chain, 592
- Fowler (Prof. A.), The Physical Society of London. Report on Series in Line Spectra, 690
- Fowler (Sir Henry), The Effect of Superheated Steam on Non-ferrous Metals used in Locomotives, 467
- Fox (Howard), [obituary article], 851
- Francé (Dr. R. H.), Das Eadophon. Untersuchungen zur Ökologie der bodenbewohnenden Mikroorganismen. Zweite Auflage, 206; Süd-Bayern, 246
- Francis (E. C.), elected Fellow and Mathematical Lecturer at Peterhouse, Cambridge, 653
- Franklin (C. S.), Short-wave Directional Wireless Telegraph, 220
- Franklin (P.), The Meaning of Rotation in the Special Theory of Relativity, 563
- Frazer (Sir James), conferment upon, of an honorary doctorate by Strasburg University, 754
- Frazer (R. A.), Surveys in Spitsbergen, 786
- Frederick (Mrs. C.), Scientific Management in the Home: Household Engineering, 177
- Fredericq (L.), New Belgium, 864
- French (Dr. J. Weir), Durability of Optical Glass, 97; The Telescope, 627
- Friend (Rev. H.), The Annelids of Iceland and the Faroes, 342
- Friend (Dr. J. Newton), The Corrosion of Iron, 731
- Froggatt (W. W.), A New Plasma belonging to the Genus *Extatosoma*, 759
- Fukuta (Sin-iti), Electrical Resistivity of Steels under Stress, 430
- Fulcher (G. S.), The Indexing of Scientific Articles, 679
- Fulton, jr. (J. F.), Animal Chlorophyll, 429
- Gagnebin (E.), The Flotation of Continents, 262
- Gain (E.), The Comparative Resistance to Heat of the Growing Points of the Embryo of the Sunflower, 64
- Gallenkamp and Co., Ltd., Catalogue of General Chemical Apparatus, 712; Rectangular Glass Jars, 89
- Gamble (J. S.), A Manual of Indian Timbers: an Account of the Growth, Distribution, and Uses of the Trees and Shrubs of India and Ceylon, with Descriptions of their Wood-Structure. Reprint, 276
- Gard (M.), The Withering of Young Walnut Trees in 1922, 686
- Garner (W. E.), Polar and Non-polar Valency in Organic Compounds, 543
- Garnett (Dr. W.), A Little Book on Water Supply, 275
- Garrett (Dr. F. C.) and Hilda Garrett, The Effect of a Lead Salt on Lepidopterous Larvæ, 380
- Garstang (Prof. W.), Songs of the Birds, 209; The Lesser Whitethroat's Fanfare, 319
- Gaschet (H.), Manuel de tournage du bois, 510
- Gatenby (Prof. J. Bronté), Sex Change in Mollusca, 544
- Gates (Prof. R. R.), Interspecific Sterility, 179, 447; Vegetative Segregation in a Hybrid Race, 463
- Gault (H.) and R. Guillemet, The Chlorination of Normal Butyl Alcohol, 436
- Gaumont (L.), A New Sound Amplifier, 863
- Gayler (Mary L. V.), The Constitution and Age-hardening of Alloys of Aluminium with Copper, Magnesium, and Silicon in the Solid State, 499
- Geddes (A. E. M.), The Structure of the Hydrogen Lines H $\alpha$  and H $\beta$ , 862; and C. A. Clarke, Turbulence, as exhibited by Anemometer Records, Smoke and Cloud Formation, 235
- Gheury de Bray (M.), an offer of NATURE volumes, 737
- Giacobini (M.), Observations of the Baade comet, made at the Paris Observatory, 723
- Gibb (Dr. A. W.), appointed Kilgour Professor of Geology in Aberdeen University, 754
- Gibbs (Dr. W. E.), The Fishing Industry, 840
- Gibson (H.), Life in Russian Universities To-day, 755
- Giddings (Prof. F. H.), Studies in the Theory of Human Society, 571
- Gilchrist (Miss G.), Bark Canker Disease of Apple caused by *Myxosporium corticolum*, 794
- Gill (E. L.), appointed an assistant in the Natural History Dept. of the Royal Scottish Museum, Edinburgh, 427
- Gill (F.), Long Distance Telephony, 718
- Gill (Rev. H. V.), Relativity and Space, 854
- Gilmore (C. W.), Redescription of an Eocene Lizard, 190
- Gilmour (J. B.), An Historical Sketch of Pharmacy in Great Britain and Ireland, 296
- Gire (G.), The Dissociation of Barium Chloroplatinate, 168
- Glazebrook (Sir R. T.), The Dictionary of Applied Physics, 699; The Legal Equivalent of the Metre, 446
- Gleichen (Maj.-Gen. Lord Edward), Transcription of Russian Names, 78, 635
- Goddard (H. H.), Juvenile Delinquency, 477
- Goddard (T. R.), appointed Curator of the Hancock Museum, Newcastle-upon-Tyne, 583
- Godlewski (Prof. T.), [obituary article], 361
- Goldie (A. H. R.), Circumstances determining the Distribution of Temperature in the Upper Air under Conditions of High and Low Barometric Pressure, 795
- Goodchild (J. H.), The Distribution of Sodium and Calcium, 589
- Goodman (Prof. J.), conferment upon, of the title of Emeritus Professor by Leeds University, 893
- Goodwin (Eng. Vice-Admiral Sir George), appointed a member of the Advisory Council to the Committee of the Privy Council for Scientific and Industrial Research, 321
- Goodwin (J. C.), The Forging of Finger-prints, 190
- Gordon (G. B.), Arab Art in America, 429; The Walls and other Antiquities of Constantinople, 89
- Gordon (Dr. M.), Bacteriology of Influenza, 293
- Gordon (Mary), Penal Discipline, 692
- Gordon (S.), Amid Snowy Wastes: Wild Life on the Spitsbergen Archipelago, 597
- Goris (A.) and P. Costy, Urease and Urea in Fungi, 623
- Gowland (Prof. W.), [obituary article], 16
- Goy (P.), Microbial Physiology and the Accessory Growth Factor, 64
- Grabau (Prof. A. W.), A Text-book of Geology. 2 parts, 143
- Grafe (Prof. V.), Chemie der Pflanzenzelle, 403
- Graham (R. B. Cunningham), W. H. Hudson Memorial, 846
- de Gramont (A.), Quantitative Researches on the Line Spectrum of Vanadium in Fused Salts, 895
- Granger (A.), The Baking of Ceramic Products in Electrically Heated Furnaces, 235
- Gray (Dr. R. C.), appointed Lecturer in Physics in the Queen's University, Belfast, 792
- Gray (T. H.), The Historical Development of the Distillation of Glycerine, 130
- Greaves (W. M. H.), elected to a fellowship at St. John's College, Cambridge, 684
- Green (Prof. A. G.), The Isolation of a New Series of Colouring Matters for Dyeing Acetate Silk, 743
- Greenhill (Sir G.), The Influence of Science, 78
- Greenish (Prof. H. G.), Pharmacognosy and the Pharmaceutical Curriculum, 233
- Greenly (Dr. E.), appointed special lecturer in Geology at the University College of North Wales, Bangor, 198
- Gregg (W. R.), Upper Air Research in America, 397
- Gregory (Prof. J. W.), awarded the Gold Medal of the Royal Scottish Geographical Society, 675; Evolution of the Essex Rivers and of the Lower Thames, 308; presented with a Gold Medal of the Société de Géographie de Paris, 820; and C. J. Gregory, Expedition to Chinese Tibet, 719; The Alps of Chinese Tibet and their Geographical Relations, 826
- Gregory (Sir Richard), conferment upon, of an honorary degree by Leeds University, 561; Educational and School Science, 355, 420; The Metric System, 744; speeches at the unveiling of a portrait medallion of Sir Norman Lockyer, 192, 194
- Gregory (Prof. W. K.), The Origin and Evolution of the Human Dentition, 834
- Grey (Prof. E. C.), Micro Methods in the Practical Teaching of Chemistry, 309
- Grier (Miss L.) and Miss A. Ashley, British Labour: Replacement and Conciliation, 1914-21. Part I, On Replacement, 145
- Griffiths (E. A.), Generation and Utilisation of Cold, 618



- Griffiths (H.), The General Principles of Chemical Engineering Design, 726; Materials of Chemical Plant Construction—Non-metals, 726
- Grignard (V.) and A. C. Purdy,  $\alpha$ - $\beta$ -dichlorethyl Ether, 299
- Grove-Hills (Col. E. H.), [death], 522; [obituary article], 551
- Gudger (Prof. E. W.), The Miraculous Draught of Fishes—An Explanation, 572
- Guillaume (A.), The Limits of Vegetation in the North and East of France, 686
- Guillaume (J.), Observations of the Sun made at the Lyons Observatory, 235
- Gillet (L.) and M. Ballay, The Vapour Pressure of some Copper-Zinc Alloys in the Solid State, 863
- Günther (H.), (W. de Haas), Technische Träume, 663
- Gupta (Hem Chandra Das), Neolithic Script in India, 365
- Gurney (J. H.), [obituary article], 781
- Guye (Prof. C. E.), The Tendencies of Modern Physics and the Conception of Matter, 558
- Haag (Prof. J.), Cours complet de mathématiques spéciales. Tome 2: Géométrie, 375
- Haddon (Dr. A. C.), Ceremonial Exchange, 472
- Hadfield (Sir Robert), gift for the purchase of books for scientific workers, 522; gift to the Metallografiska Institutet, Stockholm, for a Research Scholarship, 18; The Metallurgy of Iron and Steel, 507; The Work and Position of the Metallurgical Chemist, 51
- Haigh (T.), Determination of the Durability of Optical Glass, 97
- Haldane (J. B. S.), Sterility in Species-crosses, 748
- Haldane (Dr. J. S.), Respiration, 803
- Haldane (Viscount), The Philosophy of Humanism and of other Subjects, 471
- Hale (Dr. G. E.), A Fifty-foot Interferometer Telescope, 482; "A National Focus of Science and Research," 676; Invisible Sunspots, 395; resignation from the Committee on Intellectual Co-operation of the League of Nations, 460; The New Heavens, 2
- Hall (A. L.), A Bibliography of South African Geology to the End of 1920, 677
- Hall (Sir Daniel), Potato Wart Disease, 431
- Hall (E. H.), An Electron Theory of Electric Conduction in Metals, 687
- Hall (H. U.), The Art of the Marquesas Islanders, 128
- Halliday (Prof. W. R.) and Prof. McLean Thompson, Honey that drove Men Mad, 462
- Hallimond (A. F.) and E. G. Radley, Glauconite from the Greensand near Lewes, Sussex: the Constitution of Glauconite, 100
- Hallwachs (Prof. W.), [obituary], 158
- Halm (Dr.), The Law of Solar Rotation, 427
- Hamberg (H. E.), The Distribution of Temperature in Scandinavia, 557
- Hamy (M.), The Measurement of Small Diameters by Interference, 895
- Handley (Prof. W. S.), Cancer of the Breast and its Treatment. Second edition, 376
- Hanna (Dr. G. D.) and A. W. Anthony, Leading an Expedition to the Islands off the West Coast of Lower California, 321
- Hansen (Mdlle. V.), Baade's Comet, 613
- Harden (Prof. A.), Pasteur's Early Research in Pure Chemistry and Fermentation. Supplement (Dec. 23), xi; Vitamin Problems, 14
- Hardenburg (W. E.), Mosquito Eradication, 838
- Hardy (Prof. G. H.), Mersenne's Numbers, 542; The Theory of Numbers, 352, 381
- Hardy (G. H.), Some Australian Asilidæ (Diptera) in the National Museum, 168
- Hardy (W. B.), appointed to the Board of Trustees of the National Portrait Gallery, 394; Fishery Research, 865
- Harmer (Sir Sidney F.), elected an Honorary Fellow of King's College, Cambridge, 828; The Present Position of the Whaling Industry, 827
- Harries (Dr. A. J.), [obituary], 187
- Harries (H.), The Miraculous Draught of Fishes, 666
- Haring (H. K.), Arctic Rotifera, 55
- Harris (Prof. D. Fraser), On the Reality of Nerve-energy, 342, 666
- Harris (F. W.), The Hardness of the Brasses, etc., 532
- Harris (G. T.), Mimicry among Birds, 161
- Harrison (the late Lt.-Col. E. F.), Memorial to, at the Chemical Society, 717
- Harrison (H. T.) and others, Street Lighting, 888
- Harrison (Dr. J. W. H.), Interspecific Sterility, 312
- Harrow (Dr. B.), Glands in Health and Disease, 658
- Hartridge (Dr. H.), The Resonance Theory of Hearing, 9; and F. J. W. Roughton, Determinations of the Velocity with which Carbon Monoxide displaces Oxygen from its Combination with the Blood Pigment Hemoglobin, 758; The Velocity with which Carbon Monoxide displaces Oxygen from its Combination with Hemoglobin. 2 Parts, 685
- Harwood (Miss), Variability in the Light of Iris, 584
- Hastings (Dr. J.), [obituary], 610
- Hastings (S.), *Anellaria separata* growing in the Alps, 563
- Haswell (Prof. W. A.), Astacocroton, a New Type of Acarid, 759
- Hatschek (E.), Adhesives, 528
- Haughton (J. L.) and G. Winifred Ford, The Systems in which Metals Crystallise, 136
- Haughton (S. H.), Some Upper Beaufort Therapsida, 236
- Howard (L.), National and Provincial Museums, 320
- Hawley (Prof. R. C.), The Practice of Silviculture: with Particular Reference to its Application in the United States, 407
- Hayasaka (Prof. I.), Palæozoic Brachiopoda from Eastern Asia, 161; Some Permian Brachiopods from the Kitakami Mountains, 749
- Hayes (Dr.), Measuring the Depth of the Ocean by Sound Waves, 159
- Hayes (Dr. C. W.), Handbook for Field Geologists. Third edition, revised and enlarged by S. Paige, 412
- Hayes (S. Q.), Switching Equipment for Power Control, 373
- Heaviside (O.), presented with the Faraday Medal of the Institution of Electrical Engineers, 460
- Hebard (M.), Orthoptera and Dermaptera of Hawaii, 822
- Hedin (Dr. Sven), Southern Tibet: Discoveries in Former Times compared with my own Researches in 1906-1908, 170
- Hegner (Prof. R. W.) and Prof. W. W. Cort, Diagnosis of Protozoa and Worms Parasitic in Man, 694
- Hele-Shaw (Dr. H. S.), Education, Research, and Invention, 715
- Henderson (T.), appointed Demonstrator in Inorganic Chemistry in Leeds University, 621
- Henderson (Prof. W. D.), appointed Ray Lankester Investigator at the Marine Biological Laboratory, Plymouth, 98
- Henri (V.) and P. Steiner, Absorption of the Ultraviolet Rays by Naphthalene, 468
- Henry (Prof. A. J.), J. E. Lockwood, and D. A. Seeley, Glaze Storm in America, 91
- Henry (M.), The Incidence of Anthrax in Stock-in-Australia, 236
- Herdman (Lady), [obituary article], 708
- Herdman (Sir W. A.), H.S.H. Prince Albert of Monaco, 156
- d'Herelle (Dr. F.), The Theory of Bacteriophage, 293
- Heron (Dr. A. M.), Geology of the Mount Everest District, 22; The Rocks of Mount Everest, 462
- Heron-Allen (E.) and A. Earland, British Museum (Natural History). British Antarctic ("Terra Nova") Expedition, 1910. Natural History Report. Zoology. Vol. 6, No. 2. Protozoa, Part 2: Foraminifera, 241
- Herschel (William), Centenary of the Death of, 255
- Hertwig (Prof. R.), elected President of the Deutsche Gesellschaft für Vererbungswissenschaft, 583
- Hesse (Prof. A.) and Prof. H. Grossmann, Englands Handelskrieg und die chemische Industrie. Band 1; 2: Neue Folge; 3, Herausgegeben von A. Hesse, H. Grossmann, und W. A. Roth, 337
- Hevesy (Dr. G.), An Attempt to Influence the Rate of Radioactive Disintegration by Use of Penetrating Radiation, 216
- Hewlett (Prof. R. T.), Books on Microbiology, etc., 694
- Heywood (F.), appointed Vulcan Fellow in Manchester University, 653

- Hickman (Miss E. M.), appointed Demonstrator in the Department of Pathology and Bacteriology in Leeds University, 621
- Hicks (Prof. W. M.), A Treatise on the Analysis of Spectra : based on an Essay to which the Adams Prize was awarded in 1921, 690; Spectra on the Quantum-orbit Theory, 292; Spectrum Lines of Neutral Helium, 309
- Hickson (Prof. S. J.), Black Coral, 217
- Hilditch (Dr. T. P.), A Concise History of Chemistry. Second edition, 395
- Hilger, Ltd. (Adam), A Chemical Spectrometer, 191; An Optical Sonometer, 464; List of Interferometers, 229
- Hill (Prof. A. V.), Athletics and Oxygen Supply, 588; and W. E. L. Brown, The Oxygen-dissociation Curve of Blood and its Thermodynamical Basis, 685
- Hill (G. F.), A New Species of Mordellistena (Coleoptera, Mordellidae) Parasitic on Termites, 759; Some North Australian Termites, 236; A New Australian Termite, 500
- Hill (Prof. L.), Ventilation and Atmosphere in Factories and Workshops, 644
- Hilton (Prof. H.), Crystallographic Notation, 100; The Graphical Construction of the Constants of a Shear, 100
- Hilton-Simpson (M. W.), Folklore among the Algerian Tribes, 161
- Hinchley (Prof. J. W.), Evaporation, 130
- Hind (Prof. A. M.), Processes of Engraving and Etching, 583
- Hinschwood (C. N.), The Structure and Chemical Activity of Copper Films and the Colour Changes Accompanying their Oxidation, 62
- Hirayama (Dr. K.), Origin of the Asteroids, 53
- Hirst (S.), Mites Injurious to Domestic Animals (with an Appendix on the Acarine Disease of Hive Bees), 410
- Hitchcock (A. S.), The Grasses of Hawaii, 614
- Hoare (C. A.), Transcription of Russian Names, 279
- Hobbs (Prof. W. H.), Earth Evolution and its Facial Expression, 270
- Hobday (Prof.) and Prof. Lang, Animal and Vegetable Pathology in Relation to Human Disease, 293
- Hobson (B.), The Local Handbook of the British Association, 605
- Hodge (A. E.), The Freshwater Winkle, 380
- Hoerber (Prof.), Effect of the Ions on Physiological Surfaces, 751
- Hoernlé (Prof. K. F. A.), The Treatment of "Existence" in Recent Philosophical Literature, 830
- Hofmann (Prof. K. A.), Lehrbuch der anorganischen Chemie. Vierte Auflage, 695
- Hogan (Dr. M. A.), Current Meters for Use in River Gauging, 292
- Hogben (L. T.), Studies on Internal Secretion, I., 686; and F. K. Winton, Studies on Internal Secretion, II., 686
- Holland (J. H.), The Useful Plants of Nigeria. Part iv., 323
- Holleman (Prof. A. F.), awarded the honorary degree of D.Sc. by Leeds University, 399; Recent Researches on Substitution in the Benzene Nucleus, 19
- Holmes (M.), Orientation of Molecules in a Magnetic Field, 635
- Holmyard (E. J.), Arabic Chemistry, 573
- Holst (G.) and F. Oosterhuis, The Explosive Potential of a Gas, 623
- Holt (E. W. L.), [obituary article], 17
- Honda (Prof. K.), Bohr's model of the Hydrogen Molecules and their Magnetic Susceptibility, 664
- Hooper (C. H.), Fruit Farming: Practical and Scientific for Commercial Fruit Growers and Others. Second edition, 601
- Hopfield (J. J.), New Spectra of Water Vapour, Air, and Hydrogen in the Extreme Ultra-violet, 732
- Horstmann (Prof. A.), [obituary], 851
- Hough (C. D.), appointed Leech Fellow in Manchester University, 653
- Houstoun (Dr. K. A.), An Investigation of the Colour Vision of 527 Students by the Rayleigh Test, 794
- Howard (C. P.), The Orbit of Sirius, 461
- Howarth (O. J. R.), The British Association for the Advancement of Science: a Retrospect, 1831-1921, 302; The World About Us: a Study in Geographical Environment, 376
- Howes (H. W.), presented with the Frank Wood Medal of the Society of Glass Technology, 784
- Hrdlička (Dr. A.), The Peopling of Asia, 54
- Hudson (W. H.), [obituary article], 319; bequest to the Royal Society for the Protection of Birds, 711
- Hughes (W.), A Possible Reconciliation of the Atomic Models of Bohr and of Lewis and Langmuir, 37
- Hughes (W. E.), On the Electro-deposition of Iron, 445
- Hughesdon (R. S.), H. G. Smith, and J. Read, The Stereoisomeric Forms of Menthone, 895
- Hulme (E. W.), An Empire Patent, 633
- Humberstone (T. L.), Bloomsbury and the University of London, 150; Bloomsbury, 250; Science and Education at South Kensington, 79; The New University of London, 435
- Humbert (Prof. P.), Introduction à l'étude des fonctions elliptiques à l'usage des étudiants des facultés des sciences, 308
- Humphrey (J.), Drugs in Commerce: their Source, Preparation for the Market, and Description, 7
- Hurley (Capt. F.), Expedition to New Guinea, 393
- Hurry (Dr. J. B.), Poverty and its Vicious Circles. Second edition, 177
- Hurst (E.), H. G. Smith, and J. Read, The Chemistry of the Phellandrenes, 895
- Hutchinson (A.), proposed creation of a Lectureship in Crystallography for, in Cambridge University, 792
- Hutton (L. H.), Head-hunting in Assam, 322
- Hyman (L. H.), A Laboratory Manual for Comparative Vertebrate Anatomy, 571
- Ichester (Earl of), appointed to the Board of Trustees of the National Portrait Gallery, 394
- Imms (Dr. A. D.), New Social Coleoptera, 95; Royal Society: Reports of the Grain Pests (War) Committee, Nos. 1 to 10, 145
- Inge (Dean), elected an Honorary Fellow of King's College, Cambridge, 828; The Victorian Age: The Rede Lecture for 1922, 104
- Ingham (A. E.), elected a Fellow of Trinity College, Cambridge, 561
- Innes (R. T. A.), conferment upon, of the honorary degree of D.Sc. by the University of Leyden, 675
- Irvine (Principal J. C.), appointed a member of the Advisory Council to the Committee of the Privy Council for Scientific and Industrial Research, 321; Chemistry of the Sugars, 352; St. Andrews, 498; The Development of Research in Universities, 131; The Organisation of Research, 385;
- Irwin-Smith (Vera), A New Nematode Parasite of a Lizard, 759; Nematodes of the Genus Physaloptera. Part iii., 300; Part iv., 864
- Ishino (Dr.), Separation of Isotopes of Chlorine, 647
- Ives (Dr. H. E.), Phosphorescent Light of Fireflies, 679
- Jack (Col. E. M.), appointed Director-General of the Ordnance Survey, 158
- Jack (R. L.), Iron Ore in South Australia, 129
- Jackson (Dr. B. Daydon), The Use of the Name Forstera or Forstera, 756
- Jackson (H.), A Short Manual of Forest Management, 407; The Trend of Human Development, 554
- Jackson (Dr. Josephine A.) and Helen M. Salisbury, Outwitting our Nerves: a Primer of Psychotherapy, 477
- Jagger (T. A.), a plea for geophysical and geochemical observatories, 884
- Jameson (H. L.), J. C. Drummond, and K. H. Howard, and others, Sources of Vitamin A, 429
- Janet (Prof. P.), A Particular Class of Batteries, 235; Problèmes et exercices d'électricité générale, 147; The Standard Reproduction of the International Ohm, 235

- Jarry-Desloges (R.), Observations of Mars at Sétif, Algeria, 160; Study of the Surface of Planets, 200
- Jears (Dr. J. H.), The Propagation of Earthquake Waves, 794; The Theory of the Scattering of  $\alpha$ - and  $\beta$ -rays, 721
- Jeffcott (H. H.), The Electrical Design of A.C. High Tension Transmission Lines, 167
- Jefferson (A.), The Cause of Red Stains on Silver-plated work, 531
- Jeffreys (Dr. H.), Geology and the Primitive State of the Earth, 148
- Jenkin (C. F.), The Fatigue Failure of Metals, 794
- Jenkins (R.), Early History of the Sussex Iron Industry, 803
- Jenness (D.), The Life of the Copper Eskimos, 245
- Joachim (Prof. H. H.), Aristotle's De Generatione et Corruptione, 174
- Joerg (W. L. G.), Recent Geographical Work in Europe, 530
- Johannsen (Prof.), Heredity, 750
- Johnson (F.) and W. G. Jones, New Forms of Apparatus for determining the Linear Shrinkage and for Bottom-pouring of Cast Metals and Alloys, etc., 531
- Johnson (M. C.), elected to the Arnold Gerstenberg Studentship, Cambridge University, 620
- Johnson (N. K.), and S. N. Sen, Wind-speed from Sea and Land, 462
- Johnson (Prof. T.) and Miss J. G. Gilmore, The Lignite of the Lough Neagh Clays, 586; The Lignite of Washing Bay, Co. Tyrone; Libocedrus and its Cone in the Irish Tertiary, 167
- Johnston (Sir Harry H.), A Comparative Study of the Bantu and Semi-Bantu Languages. Vol. 2, 67
- Johnstone (S. J.), Potash. New edition, 307
- Jolibois (P.) and R. Bossuet, The Precipitation of Uranyl Nitrate by Soda, 136
- Jolly (Prof. W. A.), The Electrogram of the Frog's Gastrocnemius reflexly excited, 236; The Rhythm of Discharge of the Spinal Centres in the Frog, 468
- Joly (Prof. J.), Cosmical Theory and Radioactivity, 112; Geology and the Nebular Theory, 76; Roche's Limits for Satellites, 179
- Jones (J. H.), The Kinetic Energy of Electrons emitted from a Hot Tungsten Filament, 722
- Jones (Ll.) and F. I. Scard, The Manufacture of Cane Sugar. Second edition, 4
- Jones (Dr. O. T.), Lead and Zinc, 476
- Jones (R. Ll.), Vibration Galvanometers with Asymmetric Moving Systems, 829
- Jordan (Dr. D. S.) and J. Z. Gilbert, Cainozoic Fishes of California, 397
- Jouast (R.), Comparisons of the Standard Reproductions of the International Ohms, 235; The Application of Pyrometers to High Frequency Measurements, 863
- Joubin (L.), The Geographical Distribution of Some Deep-sea Corals in Western European Seas, 831
- Joy (A. H.), RS Canum Venaticum, 461
- Jussieu (B. de), the work of, 320
- Justesen (P.), A Remarkable Parasite, 128
- Kaburaki (T.), Some Indian Leeches, 822
- Kamensky (Prof.), The Perturbations of Wolf's Periodic Comet, 290, 525
- Kamita (K.), The Influence of Alumina in preventing the Devitrification of Sheet Glass during the Drawing Process, 63
- Kapp (Prof. G.), [obituary article], 257
- Kapteyn (Prof. J. C.), [obituary article], 48; The Arrangement and Motion of the Sidereal System, 163
- Karny (H. H.), A Remarkable New Gall-thrips from Australia, 500
- Karper (V.), A Particular Class of Batteries, 235
- Kasakov (M.), Perrine's Comet, 613
- Kaye (Major G. W. C.), Industrial Physics, 439
- Keatinge (G.), Agricultural Progress in Western India, 442
- Keen (Dr. B. A.), Position of Agriculture in India, 442
- Keen (Dr. W. W.), Science and the Scriptures, 726
- de Kegel (M.), Les Encres, les cirages, les colles et leur préparation, 731
- Keith (Sir Arthur), elected Secretary of the Royal Institution, 784; Our Nearest Living Relatives, 834; The Present Position of Darwinism as applied to the Problem of Man's Origin, 393; The Stature of the Scottish People, 8; and Prof. Karl Pearson, The Skull of Sir Thomas Browne, 149
- Kellner (Dr. W.), [death], 491; [obituary article], 522
- Kellogg (R.), Humpback Whale from the Miocene of California, 322
- Kemp (Dr. S.), Animal Associations of Some Crustacea, 888
- Kempton (P. H. S.), Industrial Nitrogen: The Principles and Methods of Nitrogen Fixation and the Industrial Applications of Nitrogen Products in the Manufacture of Explosives, Fertilizers, Dyes, etc., 805
- Kendall (Prof. F. F.), conferment of the title of Eminent Professor by Leeds University, 893; Physiography of the Coal Swamps, 353, 811; and others, Geology of the North Sea Basin, 890; Man and the Ice Age, 617
- Kendrew (W. G.), The Climates of the Continents, 630
- Kennard (A. S.), given the Foulerton Award of the Geologists' Association, 885
- Kennedy (B.), Thought-coin, 147
- Kenneth (J. H.), Bibliography on the Subject of the Organs and Sense of Smell and of Odorous Substances, 427
- Keogh (Sir Alfred), awarded the Gold Medal of the Institution of Mining and Metallurgy, 553
- Kesteven (Dr. H. L.), The Bones in the Palate and Upper Jaw of Bony Fishes, 748
- Kewley (J.), The Petroleum and Allied Industries: Petroleum, Natural Gas, Natural Waxes, Asphalts and Allied Substances, and Shale Oils, 866
- Keynes (Dr. G.), Blood Transfusion, 871
- Kidd (B.), A Philosopher with Nature, 836
- Kieran (A. J.), The Electrical Conductivity of Hydrochloric Acid and Potassium Chloride in Presence of Sucrose, 136
- Kimmins (Dr. C. W.) and others, Psycho-analysis and Education, 650
- King (Dr. H.), Muscarine, 526
- King (W.), Chelsea Porcelain, 871
- King (W. B. R.), elected Fellow and Lecturer in Natural Sciences at Magdalene College, Cambridge, 25
- King (W. J.), Exhibition of Leaf-pictures, 799
- Kipling (Rudyard), elected Rector of St. Andrews University, 684
- Kirkby (Rev. Dr. P. J.), Peculiarities of the Electric Discharge in Oxygen, 249
- Kirkpatrick (R.), Ouramœba, 40
- Kirkwood (J.), Farm Book-keeping: The Principles and Practice of Book-keeping applied to Agriculture: for Agricultural Colleges, Extension Classes, Evening Classes, and Practical Farmers, 768
- Kling (A.) and D. Florentin, The Spontaneous Formation of Sulphate on Limestone in Urban Centres, 831
- Klingstedt (F. W.), The Ultra-violet Absorption Spectra of the Diphenols, 436
- Knaggs (Miss I. E.), The Connexion between Crystal Structure and Chemical Constitution of Carbon Compounds, 756
- Knott (Dr. C. G.), [death], 610; [obituary article], 640; C. A. Stevenson and the "Cable Guide," 88
- Knowles (J. A.), Processes and Methods of Medieval Glass Painting, 687
- Knox-Shaw (H.), Observations of Solar Radiation, 1915-1921, 799
- Knudsen (Prof.), elected an honorary member of the Royal Institution, 784
- Koch (L.), R. C. Wilson, and E. de Margerie, The Geological Mapping of the Globe, 91
- Kodak, Ltd., Photomicrography, Sixth edition, 679
- Koehler (Prof. R.), New Antarctic Brittle-stars, 713
- Kraus (Prof. C. A.), The Metallic State, 165
- Kuenen (Prof. J. P.), [death], 491; [obituary article], 673
- Kugelmass (I. N.), A New Apparatus, the Nephelectrometer, 400
- Kuhlbrodt (Dr. E.), New Theory of Cyclones, 91

- L. (J.), A Type of Ideal Electric Atoms, 873  
 Lacoste (J.), New Radiogoniometric Observations of Atmospherics, 686  
 Lake (P.), Wegener's Displacement Theory, 77  
 Lamb (C. G.), appointed Reader in Electrical Engineering in Cambridge University, 653  
 Lambert (P.) and A. Andant, An Arrangement for Depositing Films of Metal on Large Surfaces by Cathodic Projection, 268  
 Lang (Dr. W. D.), Catalogue of the Fossil Bryozoa (Polyzoa) in the Department of Geology, British Museum (Natural History). The Cretaceous Bryozoa (Polyzoa). Vol. 4: The Crabrimorphs. Part 2, 445  
 Lange (C. G.) and W. James, The Emotions, 730  
 Langley (G. J.), appointed Honorary Assistant Lecturer in Physiology in Manchester University, 653  
 Langmuir (Dr. I.), elected an Honorary Member of the Royal Institution, 784  
 Langton (Dr. H.), [death], 742  
 Lapage (Dr. G.), Ouramöba, 114  
 Lapique (L.), Mechanism of the Exchanges between the Cell and the Surrounding Medium, 28  
 Laplace (Pierre-Simon), Essai philosophique sur les probabilités, 6  
 Larbaud (Mlle. Marguerite), The Anatomy of Flowers of the Same Species at Different Altitudes, 64  
 Larmor (Sir Joseph), Prof. H. Rubens, 741  
 Larsen (E. S.), The Microscopic Determination of the Non-opaque Minerals, 261  
 Lassar-Cohn (Prof.), [death], 641  
 Laue (Prof. von), The Theory of Relativity, 750  
 Laurie (Prof. A. P.), Chemical Combination and Sir Alfred Ewing's Magnetic Atom, 100; The Preservation and Cleaning of Pictures, 710; The Preservation from Decay of Stone on Buildings, 746  
 Lavington (F.), elected a Fellow of Emmanuel College, Cambridge, 25  
 Lea (Prof. F. C.), Effect of Temperature on Some Properties of Metals, 41; Elementary Hydraulics for Technical Students, 839  
 Leahy (Prof. A. H.), appointed Emeritus-Professor of Mathematics in Sheffield University, 562  
 Lebeau (P.) and M. Picon, The Reactions furnished by Sodammonium with Hydrocarbons, 299  
 Leblanc (M.), A New Freezing Machine with Air as the Working Fluid, 136; Lamps with Three Electrodes, Anode, Cathode, and Intermediate Grid where the Current is carried by Ions, and their Applications, 268; The Use of Air as a Cooling Agent, 63  
 Lecher (Dr. H.), appointed Professor of Organic Chemistry in Freiburg University, 466  
 Le Danois (E.), The Hydrology of the North Atlantic, 655  
 Ledingham (Prof. J. C. G.), Pasteur and Preventive Medicine. Supplement (Dec. 23), viii  
 Le Gavrian (Prof. P.), Les chaussées modernes, 272  
 Legendre (J.), The Trophic Rôle of Birds as regards the Culicines, 655  
 Legendre (R.), Diurnal Variations of the Hydrogen Ion Concentration of Sea Water near the Coast, 724  
 Leger (M.) and A. Baury, Healthy Carriers of the Plague Bacillus, 687  
 Legrain (L.), The Oldest-dated Seal Cylinders, 462  
 Loith (C. K.), The Economic Aspects of Geology, 143  
 Lemay (P.) and L. Jalouste, Some Microbiological Consequences of the Oxidising Properties of Thorium-X, 863  
 Lemoine (Prof. G.), [obituary article], 850  
 Lenoir (M.), Somatic Kinesis in the Aerial Stem of *Equisetum arvense*, 64  
 Lenox-Conyngham (Sir G. P.), Gravity Variations, 874  
 Lenz (Dr.), Heredity in the Human Race, 750  
 Lertes (Dr. P.), Die drahtlose Telegraphie und Telefonie, 273  
 Lesage (P.), The Comparative Action of Sylvinit and its Components on the First Development of Plants, 831  
 Lescarbours (A. C.), edited by R. L. Smith-Rose, Radio for Everybody, 695  
 Leslie (J. C.), appointed District Lecturer in Agriculture in Leeds University, 621  
 Lethaby (W. R.) and others, Town Theory and Practice, 307  
 Levene (Dr. P. A.), Hexosamines and Mucins, 292  
 Levi-Civita (Prof. T.), awarded the Sylvester Medal of the Royal Society, 674, 788  
 Lewis (Prof. W. C. McC.), Colloid Chemistry, 892  
 Lewkowitsch (Dr. J.), Sixth edition, revised by G. H. Warburton, Chemical Technology and Analysis of Oils, Fats, and Waxes. Vols. i. and ii., 109  
 Lidstone (F. M.), Molecular Viscosity, 733  
 Lindemann (Prof. F. A.) and G. M. B. Dobson, A Theory of Meteors and the Density and Temperature of the Outer Atmosphere to which it leads, 794  
 Lindet (L.), The Coagulation of Latex, 758  
 Lindh (A.), The Absorption Spectrum of Sulphur for the X-rays, 200  
 Lindsay (A. D.), appointed Professor of Moral Philosophy in Glasgow University, 25  
 Line (J.), elected a Fellow of Emmanuel College, Cambridge, 25  
 Lineham (J.), awarded the degree of Ph.D. by Bristol University, 466  
 Ling (Prof. A. R.), Pasteur and the Fermentation Industries. Supplement (Dec. 23), xii; Sugar Technology, 4  
 Lingen (J. S. van der), A Cystoscopic Irradiator and an Ultra-violet Light Illuminator, 236  
 Little (E. M.), Artificial Limbs and Amputation Stumps: a Practical Handbook, 805  
 Lloyd (J. A. T.), The Problem of Laughter, 396  
 Lockyer (Lady), Biography of Sir Norman Lockyer, 481  
 Lockyer (the late Sir Norman), Unveiling of a Portrait Medallion of, at the Norman Lockyer Observatory: Speeches by Sir Frank Dyson and others, 192  
 Lockyer (Dr. W. J. S.), Report of the Norman Lockyer Observatory, 1921-22, 53; Solar Prominences and the Corona, 20; Spectroscopic Studies of Stellar Velocities, 95; The Determination of Stellar Distances, 219; The Sun's Activity, 1890-1920, 465  
 Locquin (R.) and S. Wouseng, The Preparation of the Dialkylvinyl-carbinols, 63  
 Lodge (Sir Oliver), Bohr and Langmuir Atoms, 341; One Possible Cause for Atmospheric Electric Phenomena—A Query, 512; Relativity and the Æther, 446; Science and Philosophy, 887; Speculation concerning the Positive Electron, 696; The Influence of Science, 277  
 Loisel (P.), The Radioactivity of the Springs of the Region of Bagnoles-de-l'Orne and its Relation to the Geological Structure, 795; and Michaleesco, The Radioactivity of the Springs of the Baths of Hercules in Roumania, 863  
 Longchambon (H.), The Tritoluminescence Spectrum of Saccharose, 136  
 Longman (H. A.), *Dicrostichus magnificus*, Rainbow, 495  
 Lorimer (Sir William), bequest to Glasgow University, 26  
 Lotsy (Prof. J. P.), Interspecific Sterility, 843  
 Louis (Prof. H.), Ore Deposits, 205  
 Love (Prof. A. E. H.), Theoretical Mechanics: an Introductory Treatise on the Principles of Dynamics, with Applications and Numerous Examples. Third edition, 243  
 Love (E. F. J.), Gravity Determinations in Australia, 563  
 Lowe (E. E.), Presidential Address to the Museums Association, 163  
 Lowndes (A. G.), The Pigeon Tick, 380  
 Lowry (Prof. T. M.), Inorganic Chemistry, 374; Intramolecular Ionisation, 757; The Manufacture of Acids during the War, 777; and L. P. McHatton, The Powdering of Minerals by Decrepitation, 135; and E. E. Walker, Expansion and Shrinkage during Caking of Potassium Carbonate, 135  
 Lugeon (Prof. M.), conferment upon, of an honorary doctorate by Paris University, 754  
 Lull (Prof. R. S.), appointed Director of the Peabody Museum of Natural History, 675  
 Lundbeck (W.), Diptera Danica: Genera and Species of Flies hitherto found in Denmark. Part VI.: Pipunculidæ and Phoridae, 602  
 Lundberg (G. C.) and the late W. P. Maycock, "Lektrik" Lighting Connections. Seventh edition, 176  
 Lundegårdh (Dr. H.), Handbuch der Pflanzenanatomie: Zelle und Cytoplasma, 176

- Lundmark (K.), Nova T Coronæ (1866), 493  
 Lundsgaard (C.) and D. D. Van Slyke, The Quantitative Influences of certain Factors involved in the Production of Cyanosis, 564  
 Lyman (Prof. T.), Acoustic Research, 773; The Spectrum of Helium in the Extreme Ultra-violet, 278  
 Lyons (Col. H. G.), Science in Egypt, 283
- MacAdam (Dr. W.), appointed Medical Tutor and Registrar of Leeds University, 133  
 Macalister (Prof. R. A. S.), Rock Carvings and Inscribed Symbols of the Neolithic and Bronze Ages, 852  
 MacFarland (Sir J. H.), The Melbourne University Bill, 39  
 MacGarr (L.), The Rural Community, 412  
 MacGregor (A. M.), The Matrix of Diamond, 262  
 MacIntire (Prof. H. J.), The Principles of Mechanical Refrigeration, 36  
 Mackenzie (D. A.), Colour Symbolism, 261  
 Mackie (T. J.), The Protective Action of Normal Serum in Experimental Infection with *Bacillus diphtheriæ*, 236; The Serum Constituents responsible for the Sachs-Georgi and the Wassermann Reactions, 832  
 MacLeod (Prof. J. J. R.) and others, Physiology and Biochemistry in Modern Medicine. Fourth edition, 872  
 MacMahon (Major P. A.), Repeating Patterns as Decorations, 162  
 Macmichael (H. A.), Pottery-making on the Blue Nile, 713  
 MacNaughten (H.), Émile Coué: The Man and his Work, 376  
 Maggini (M.), drawings of Mars, 364; The Rôle of Anomalous Dispersion in the Spectra of Stars, 723  
 Mair (Prof. A.), Research, 134  
 Maistre (C. le), elected an honorary member of the Royal Dutch Institute of Engineers, 188  
 Malan (H. L.) and A. I. Robinson, The Weighing and Measuring of Chemical Substances, 726  
 Malet (H.), Étude géométrique des transformations birationnelles et des courbes planes, 276  
 Malinowski (Dr. B.), Argonauts of the Western Pacific: an Account of Native Enterprise and Adventure in the Archipelagos of Melanesian New Guinea, 472  
 Mallik (Prof. D. N.), The Elements of Astronomy, 731  
 Mallock (A.), Action of Cutting Tools, 277, 603; Dampier's "Discourse of the Winds" and the Distribution of Wind on the Earth's Surface, 478; Divided Composite Eyes, 770; Metallic Coloration of Crystals, 344  
 Mallory (G. L.), The Mount Everest Expedition, 582  
 Mangin (L.) and N. Patouillard, The Destruction of the Woodwork on the Château of Versailles by *Phellinus cryptarum*, 467  
 Mann (F. G.), appointed Assistant to the Professor of Chemistry in Cambridge University, 590  
 Mann (J. C.), appointed Assistant Lecturer in Agricultural Chemistry in Leeds University, 621  
 Mann (Dr. J. D.), Sixth edition, revised throughout by Dr. W. A. Brend, Forensic Medicine and Toxicology, 571  
 Manson (Sir Patrick), a commemorative medal of, presented to Lady Manson, 492  
 Mansuri (Q. A.), Intermetallic Actions, 531  
 Mauguene (Prof. L.), Précis de physiologie végétale, 177; and E. Demoussy, The Influence of Calcium on the Utilisation of the Reserves during the Germination of Seeds, 290  
 Marage (M.), Phonation and Telephonic Audition, 687  
 Marchal (Mlle. G.), The Dissociation of Beryllium Sulphate, 299  
 Marchant (W. H.), Marine Wireless Pocket Book for the Practical Operator and Student, 273  
 Mariller (C.) and Van Ruyambeke, A Method for the Preparation of Commercial Absolute Alcohol and its Application to the Preparation of a National Motor Fuel, 623  
 Marion (C. F.), plea for a 13-month calendar, 747  
 Marks (P. L.), the duties of secretaries, 51  
 Marsh (S.) and A. E. Evans, Measurements of Electrode Potential Drop with Direct Current and Alternating Current Electrolysis, 722
- Martel (E. A.), Nouveau Traité des eaux souterraines, 242  
 Martin (Prof. A. S.) and Dr. C. V. Weller, The Medical Aspects of Mustard Gas Poisoning, 32  
 Martin (Dr. G.), assisted by J. M. Dickson and Maj. J. W. Christelow, Modern Chemical Lecture Diagrams, with Uses and Applications fully described, 571  
 Martin (Dr. L. C.), A Florentine School of Physics and Optics, 496; A Physical Study of Coma, 591  
 Martin-Leake (Lt.-Col. A.), presented with the gold medal of the British Medical Association, 294  
 Marvin (F. S.), Unified Human History, 867; and others, The Correlation of the Social Sciences, 682  
 Mascart (J.), The Proportion of Successes in Weather Prediction, 655  
 Mason (Dr. J. A.), Discovery of the Ruins of an Ancient City in Colombia, 459  
 Mason (T. G.), Growth and the Transport of Organic Substances in Bitter Cassava (*Manihot utilissima*), 831  
 Massart (Prof. C.), leading a biological expedition to Brazil, 126  
 Masters (F. H.), A Question of Nomenclature, 543  
 Mathias (E.), Dr. C. A. Crommelin, and Prof. H. Kamerlingh Onnes, The Rectilinear Diameter of Neon, 831  
 Matignon (C.) and M. Fréjacques, Transformation of Gypsum into Ammonium Sulphate, 200  
 Matley (Dr. C. A.), Cretaceous Fossil Reptiles in India, 90  
 Matthew (W. D.) and B. Brown, American Cretaceous Dinosaurs, 21  
 Matthews (L. H.) and A. D. Hobson, The Pigeon Tick, 313  
 Maudslay (Dr. A. P.), elected an Honorary Fellow of Trinity Hall, Cambridge, 893  
 Mavrogordato (A.), Experimental Silicosis of the Lungs, 366  
 Maw (Dr. W. H.), Progress in Engineering, 857  
 Mawer (Prof. A.), A Survey of English Place-names, 133  
 Maxwell (Sir Herbert), Defoliation of Oaks, 344; The Miraculous Draught of Fishes, 666  
 Mayer (Prof. A.), [death], 491  
 Mayer (Prof. A.), "Bayer 205," 751  
 Mayor (Dr. A. G.), [obituary article], 224  
 Mazé (P.), The Practical Conditions for using Calcium Cyanamide as a Manure, 864  
 McAdie (Prof. A.), Monsoons as Rain Makers, 324  
 McCall (Prof. W. A.), How to Measure in Education, 601  
 McCandlish (Prof. A. C.), The Feeding of Dairy Cattle, 695  
 McClean (Lt.-Col. F. K.), speech at the unveiling of a portrait medallion of Sir Norman Lockyer, 192  
 McClean (Capt. W. N.), Land and Sea Speed Reckoner, 308  
 McClure (Canon E.), [obituary], 781  
 McCready (J. A.), a new height record, 87  
 McCreath (H. M.), elected Principal of the East Anglian Institute of Agriculture, 530  
 McHargue (J. S.), Manganese in Plant Nutrition, 396  
 McKechnie (Lt.-Col. W. E.), The Sense of Smell in Birds, 784  
 McKeehan (L. W.), Crystal Structure of Beryllium and Beryllium Oxide, 563  
 McLaren (H.), conferment upon, of an honorary degree by Leeds University, 561  
 McLean (Prof. R. C.), A Broadcast "Rainbow," 605  
 McLeod (Dr. J. W.), elected to the Sir Edward Brotherton Chair of Bacteriology in Leeds University, 25  
 McLintock (W. F. P.) and F. R. Ennos, The Structure and Composition of the Strathmore Meteorite, 99  
 McLuckie (J.), Studies in Symbiosis. Part II, 500  
 McMichael, Ltd. (L.), Catalogue of Wireless Telegraph and Telephone Apparatus, 427  
 McRobert (Sir Alexander), [obituary], 17  
 McTaggart (Dr. J. McT. E.), Studies in the Hegelian Dialectic. Second edition, 208  
 McVail (Dr. J. C.), presented with the Stewart Prize of the British Medical Association, 294  
 Mechan (H.), gift by, to Glasgow University, 859; acceptance of, 893  
 Meek (Prof. A.), Sense of Smell in Birds, 279  
 Mees (Dr. C. E. K.) and G. Gutekunst, Sensitisers for the Extreme Red, 366  
 Meggett (F. J.), appointed Professor of Biological Science at Rangoon University, 720  
 Meidell (B.), A Problem of the Calculus of Probabilities and of Mathematical Statistics, 758

- Meisenheimer (Prof.), Results of Experiments in crossing Flowers, Insects, and Guinea-pigs, 750
- Mellanby (Prof.) and others, Alcohol as a Beverage in its Relation to certain Social Problems, 294; and W. Kerr, The Supersaturated Condition as shown by Nozzle Flow, 41
- Mellor (Dr. J. W.), A Comprehensive Treatise on Inorganic and Theoretical Chemistry. Vols. i. and ii., 801
- Mendel (Gregor), the centenary of the birth of, 362
- Mendiola (N. B.), Relation of Transpiration to Dry Weight in Tobacco Plants, 679
- Mengel (O.), The Fall of Dust called a "Rain of Blood," 299
- Menzel (D. H.), New Nebulae, 364
- Menzies (A. C.), The Secondary Spectrum of Hydrogen, 876
- Mercanton (P. L.), The Glacial System of the Beerenberg of Jan Maven, 28
- Merton (G.), Skjellerup's Comet, 160
- Merton (Prof. T. K.), The Structure of the Red Lithium Line, 632; and D. N. Harrison, Errors arising in the Measurement of Unsymmetrical Spectrum Lines, 62
- Merz (A.), Surface Temperatures in German Lakes, 229; and G. Wüst, Vertical Circulation in the Atlantic, 262
- Mestrézat (W.), P. Girard, and V. Morax, The Elective Ionic Permeability of the Cellular Elements, 168
- Metcalf (L.) and H. P. Eddy, Sewerage and Sewage Disposal: a Textbook, 510
- Metropolitan Vickers Co., Ltd., a Wireless Receiving Set, 324, 426
- Meyer (Sir W. Stephenson), bequests to University College, London, and Madras University, 754; acceptance by London University of a bequest by, 859
- Michaelis (Prof. L.), Die Wasserstoffionen-Konzentration: ihre Bedeutung für die Biologie und die Methoden ihrer Messung. Zweite Auflage. Teil i., 305
- Michelson (Prof. A.), conferment upon, of an honorary doctorate by Paris University, 754
- Mickleth (E. R.), Miracles and the New Psychology: a Study in the Healing Miracles of the New Testament, 630
- Middleton (G. G.), presented with the Frank Wood Medal of the Society of Glass Technology, 784
- Migeod (F. W. H.), Desiccation in the Lake Chad Region, 786
- Miller (A.), Oil-drilling in Galicia, 749
- Miller, jr. (G. S.), Mammals from Haitian Caves, 855
- Miller (H. W.), [obituary], 851
- Miller (J. A.) and J. H. Pitman, The Masses of Visual Binary Stars, 555
- Milligan (H. N.), The Horniman Museum: a Handbook to the Collections illustrating a Survey of the Animal Kingdom. Second edition, 412
- Millikan (Dr. R. A.), appointed a member of the Committee on Intellectual Co-operation of the League of Nations, 460
- Mills (J.), Within the Atom: a Popular View of Electrons and Quanta, 246
- Milne (E. A.), Radiative Equilibrium, 62
- Milner (H. B.), An Introduction to Sedimentary Petrography: with special reference to loose Detrital Deposits and their Correlation by Petrographic Methods, 804; Natural Gas Gasoline: The Production of Light Oils from Natural Gas, 791; The Petroleum Industry, 474
- Minton (J. P.), Some Cases of Nerve-deafness and their Bearing on Resonance Theories of Audition, 563
- Mirande (M.), The Influence of Light on the Formation of Anthocyanine in the Scales of the Bulbs of Lilies, 592; The Morphological Origin of the Internal Liber of the Nolanaceæ and the Systematic Position of this Family, 436
- Mitchell (C. Ainsworth), Inks, 426; The Colorimetric Estimation of Pyrogallol, Gallotannin, and Gallic Acid, 722
- Mitchell (J.), A New Gasteropod (fam. Euomphalidæ) from the Lower Marine Series of N.S.W., 300
- Mitchell (Dr. S. A.), Parallaxes of 22 Cepheids, 493
- Mitchell (Dr. T. W.), The Psychology of Medicine, 412
- Mittell (E. E. G.), Continuous Wave Wireless Telegraphy: a Non-mathematical Introduction to the Subject of Wireless Telegraphy from the Engineer's Point of View, 273
- Mitzakis (M.), The Oil Encyclopedia, 474
- Moir (J.), Colour and Chemical Constitution. Pt. xvii., 64; Pt. xviii., 832
- Moir (J. Reid), The Red Crag Flints of Foxhall, 188
- Moir (P. J.), appointed a Clinical Assistant in Surgery in Leeds University, 133
- Möller (Prof. A.), [death], 781
- Monaco (Albert, Prince of), [death], 17; [obituary article], 156; bequests by; resolution concerning, by the Marine Biological Association of the United Kingdom, 88; bequests for scientific purposes, 524
- Monier-Williams (G. W.), Power Alcohol: Its Production and Utilisation, 172
- Monkhouse (Dr. A. C.), appointed Research Assistant in the Fuel Industries Department of Leeds University, 621
- Moon (F. W.) and H. Sadek, Topography and Geology of Northern Sinai, 175
- Moore (A. S.), A New Textile Fibre, 679
- Moore (C. N.), Generalised Limits in General Analysis, 687
- Moore (Miss E. S.), The Physiology of the Dry-rot Disease of Potatoes in Storage caused by *Fusarium caruleum*, 795
- Moore (Dr. G. E.), Principia Ethica, 74
- Moore (Sir Norman), [death], 781; [obituary article], 817
- Moore (T. F.), [obituary], 641
- Moreux (l'Abbe Th.), Origine et formation des mondes, 660; Pour comprendre Einstein, 568
- Morris (R. L.), Further Notes on the Estimation of Potassium, 723
- Morrison (F. R.), The Essential Oil of *Kunzea corifolia*, 896
- Mortensen (Prof. Th.), Echinoderm Larvæ and their Bearing on Classification, 806
- Moss (Asst. Prof. K. N.), appointed Professor of Coal and Metal Mining in Birmingham University, 368
- Mossman (R. C.), Recent Remarkable Temperatures, 126
- Mouat-Biggs (Major C. E. F.), Scorpions and their Venom, 250
- Moureu (C.) and C. Dufraisse, Auto-oxidation, 268
- Mukherjee (Prof. J. N.), Experiments on the Theory of Soil-acidity, 732
- Mulder (Prof. M. E.), The "Green Ray" or "Green Flash" (Rayon Vert) at Rising and Setting of the Sun, 370
- Munby (A. E.), American Research on Acoustics, 575
- Munday (A. H.), C. C. Bissett, and J. Cartland, White Metals, 467
- Murke (Dr. F.), Condensed Description of the Manufacture of Beet Sugar, 4
- Murray (Miss), Excavations at Borg en Nadur, Malta, 859
- Murray (Miss M. M. A.), elected to the London University Studentship in Physiology for 1922-23, 25
- Musgrave (H.), bequest to the Queen's University, Belfast, 828
- Musgrave (J. L.), Heating and Ventilation in Passenger Ships, 586
- Myers (Dr. C. S.), The Influence of the late W. H. R. Rivers on the Development of Psychology in Great Britain, 392, 485; The Various Factors involved in the Appreciation of Music, 232
- Nakano (H.), Ecology of "Floating Islands," 646
- Nanji (D. R.), appointed Assistant Lecturer and Demonstrator in Brewing and Fermentation in Birmingham University, 684
- Narayana (Prof. A. L.) and D. Gunnaiya, Absorption of Potassium Vapour in the Associated Series, 250
- Nash (A. W.), appointed Lecturer in Oil Mining in Birmingham University, 684
- Natanson (Prof. L.), University Education in Poland, 828
- Needham (N. J. T. M.), elected to the Benn W. Levy Research Studentship in Biochemistry, Cambridge University, 620
- Nernst (Prof.), Photo-chemical Processes, 751
- Neuhausen (Dr. B. S.), Condition of Electrolytes in the Blood, 8; The Sense of Smell in Birds, 677
- Newbigin (A. M.), Solar Prominence Observations, 1921, 20
- Newbigin (Dr. Marion), Human Geography, 353, 416; Frequent Ways: a General Survey of the Land Forms and Vegetation of Western Europe, considered in their Relation to the Life of Man, including a Detailed Study of Some Typical Regions, 599

Newcombe (Dr. C. F.), The Kwakiutl Indians, 190  
 Newman (Sir George), Maternity and Child Welfare, 232  
 Newnham (E. V.), Formation of Thunderstorms, 129  
 Newsholme (Sir Arthur), Compulsion and Education in  
 Public Health Work, 232; Relative Values in Public  
 Health, 820, 853  
 Newton (R. B.), E. Heron-Allen, and A. Earland, Eocene  
 Mollusca and Foraminifera from Nigeria, 322  
 Nicholls (J. R.), The Estimation of Morphine, 722  
 Nicholson (Prof. J. W.), The Difference between Series  
 Spectra of Isotopes, 37  
 Nicloux (M.) and G. Welter, Does Cyanic Acid exist in  
 the Blood? 168  
 Nicolas (G.), A New Host of Phyllosiphon, 300  
 Nicoresti (A. C.), Heat and Light in Chemical Com-  
 bination with other Elements, 524  
 Nierenstein (Dr. M.), Black Coral, 313; Tinctorial  
 Chemistry and Histology, 33  
 Nishimura (M.), Meadow Grasses, 855  
 Nobbe (Prof. F.), [death], 610  
 Nobécourt (P.), The Mechanism of the Parasitic Action  
 of *Penicillium glaucum* and of *Mucor stolonifer*, 168  
 Noddack (Dr.), appointed Director of the Physikalis-  
 Technische Reichsanstalt, 554  
 Nodon (Dr. A.), Earth Currents in France, 888  
 Noel (Capt. J. B. L.), a film record of the Mount Everest  
 Expedition, 743  
 Noelting (Prof. E.), [obituary], 425  
 Nordenskiöld (Baron E.), The Copper and Bronze Ages  
 of South America, 141; The Roman Balance in  
 South America, 526  
 Nordmann (C.) and Le Morvan, Observations of Stars  
 of the N Type, 167  
 Normand (Dr. C. W. B.), Dust-raising Winds, 262  
 Norris (Prof. J. F.) and Prof. K. L. Mark, Laboratory  
 Exercises in Inorganic Chemistry, 602  
 Norris (K.), an Albino Crested Newt, 188  
 Norrish (R. G. W.), awarded the Gordon Wigan Prize  
 of Cambridge University, 828  
 Norton (L. E.), The Apparent Swelling of Sand on the  
 Addition of Water, 63  
 Noyes (A. A.) and H. A. Wilson, Thermal Ionisation of  
 Gaseous Elements at High Temperatures, 687  
 Nuthall (A. W.), to be the Ingleby Lecturer in Birmingham  
 University for 1924, 60  
 Nys (Prof. D.), La Notion d'espace, 471

Occhialini (A.), Elettrotecnica elementare con numerosi  
 problemi. Vol. i., 474  
 O'Connell (Marjorie), Phylogeny of Ochetoceras, 322  
 O'Dwyer (Margaret H.), Protein Precipitation in Grasses,  
 759; The Nutritive Value of Certain Australian  
 Grasses, 759  
 Ogden (C. K.), I. A. Richards, and J. Wood, The Founda-  
 tions of Aesthetics, 375  
 Oldham (R. D.), Gravity Observations in India, 665;  
 The Earthquake of August 7, 1895, in Northern  
 Italy, 757  
 Ollivier (Prof. H.), Cours de physique générale à l'usage  
 des candidats au certificat de Physique générale,  
 au diplôme d'Ingénieur-Électricien et à l'Aggrégation  
 des Sciences physiques. Tome ii. Deux. édition,  
 405  
 Olufsen (Prof.), leader of a Danish expedition to the  
 Sahara, 643  
 Oman (Sir Charles W. C.), appointed Creighton Lecturer  
 in the University of London for 1922-23, 25  
 Omori (Prof.), Earthquakes in the Region around Tokyo,  
 162  
 O'Neill (H.) and Dr. F. C. Thompson, A Curious Feature  
 in the Hardness of Metals, 773  
 Onnes (Prof. H. Kamerlingh), elected a Corresponding  
 Member of the Prussian Academy of Sciences, Berlin,  
 158; Prof. J. P. Kuenen, 673  
 Onslow (Hon. V. A. H. H.), [obituary article], 85  
 Orr (J.), A Short History of British Agriculture, 204  
 Orton (Dr. J. H.), Occurrences of a Crystalline Style  
 in the American Slipper Limpet (*Crepidula fornicata*)  
 and its Allies, 149; Occurrence of the Archiannelids,  
 Saccocirrus and Protodrilus on the South and West

Coasts of England, 574; The Hermit-crab (*E.  
 bernhardus*) and the Anemone (*C. (Sagartia) para-  
 sitica*), 877; The Mode of Feeding of the Jelly-fish,  
*Aurelia aurita*, on the Smaller Organisms in the  
 Plankton, 178; The Phenomena and Conditions of  
 Sex-change in the Oyster (*O. edulis*) and *Crepidula*,  
 212; The Relationship between the Common Hermit-  
 crab (*Eupagurus bernhardus*) and the Anemone  
 (*Sagartia parasitica*), 735  
 Osborn (Prof. H. F.), Fossil Vertebrates in Central Asia,  
 646; Pleseropithecus, the Anthropoid Primate of  
 Western Nebraska, 281; The American Museum  
 Ideal, 880; The Ethnology of Scandinavia, 190  
 Osborne (G. D.), The Geology and Petrography of the  
 Clarencetown-Paterson District. Part i., 236; Part  
 ii., 864  
 Ostenfeld (Prof. C. H.) and Dr. O. Paulsen, A List of  
 Flowering Plants from Inner Asia, collected by Dr.  
 Sven Hedin, determined by various authors, 170  
 Ostwald (Prof. W.), New Methods of Quantitative  
 Determination of Colours, 751  
 Owen (Dr. E. A.), The Sphere-gap Voltmeter, 615

Page (Prof. L.), An Introduction to Electrodynamics :  
 from the Standpoint of the Electron Theory, 509  
 Paget (S.), Pasteur. Supplement (Dec. 23), iii  
 Palmer (L. S.), appointed Assistant Lecturer in Electrical  
 Engineering in Manchester University, 653  
 Panisset (L.) and J. Verge, The "donneurs de sang"  
 in Veterinary Medicine, 136; and E. Grasset, The  
 Fixation-reaction in the Diagnosis of Tuberculosis  
 in Cattle, 268  
 Parcot (Abbé L.), the work of B. de Jussieu, 320  
 Paris (Capt. E. T.), The Production of a Standard Source  
 of Sound, 378  
 Parker (the late Prof. T. J.) and Prof. W. A. Haswell,  
 A Text-book of Zoology. In two volumes. Third  
 edition, 765  
 Parker (Dr. W. R.), offer for the preservation of fossils  
 found in the United Kingdom, 460  
 Parkhouse (A. W.), Practical Polishing and Staining, 147  
 Parkin (Sir George R.), [obituary article], 49  
 Parkinson (J.), The Primitive Crust of the Earth, 413  
 Parrish (P.), The Design of Ammoniacal Liquor Stills, 130  
 Parsons (A. C.) and others, Ministry of Health. Reports  
 on Public Health and Medical Subjects. No. 11 :  
 Report on Encephalitis Lethargica, 626  
 Parsons (Sir Charles), elected an Honorary Member of the  
 Royal Dutch Institute of Engineers, 188  
 Parsons (Sir J. Herbert), Physiological Aspects of Physical  
 Measurement, 824  
 Partington (Prof. J. R.), Research and Razors, 415  
 Pascal (P.), Magnetic Analysis of Silicates and the Silicic  
 Acids, 758; Magnetic Analysis of the Stannic Acids, 863  
 Pascoe (Dr. E. H.), Geology of Mesopotamia, 21  
 Pasquier (Prof. L.-G. du), Le Principe de la relativité et  
 les théories d'Einstein, 568  
 Pasteur (Louis), Supplement (Dec. 23), iii to xiv  
 Pastorelli and Rapkin, Ltd., list of Thermographs and  
 Hydrographs, 52  
 Patrick (Dr. Dorothy M.), appointed Assistant Lecturer  
 in Physiology in Birmingham University, 859  
 Patton (R. T.), The Drying of Timber, 332  
 Patton (Major W. S.), the genus *Musca*, 396  
 Payton (C. G.), appointed Demonstrator in Anatomy in  
 Birmingham University, 60  
 Peacock (A. D.), Pairing and Parthenogenesis in Saw-  
 flies, 215  
 Peacock (D. H.), appointed Professor of Chemistry at  
 Rangoon University, 720  
 Peacock (H. A.), The Presence of Sulphur Dioxide in  
 Cattle Foods after Fumigation, 804  
 Peake (H.), The English Village: the Origin and Decay  
 of its Community. An Anthropological Interpretation,  
 371  
 Peake (H. J. E.), The Study of Man, 354, 516  
 Pearl (Prof. R.) and T. J. Le Blanc, Further Note on the  
 Age Index of a Population, 687  
 Pearsall (Dr. W. H.), appointed Reader in Botany in  
 Leeds University, 893

- Pearson (E. S.), Variations in Personal Equation, 827  
 Pearson (Prof. Karl), Francis Galton, 1822-1922: a Centenary Appreciation, 335; Health and Weight Probabilities, 228; Tables of the Incomplete Gamma-function, 669; and E. S. Pearson, How to find a General Polychoric Coefficient of Correlation, 827  
 Pease (R. N.), Atoms and Electrons, 379  
 Peddie (Prof. W.), Self Light, Fatigue, Inhibition, and Recurrent Visual Images, 100  
 Peel (R.), An Elementary Text-book of Coal-mining. Revised and enlarged by Prof. D. Burns. Twentieth edition, 628  
 Peirce (J. D.), The Giant Trees of Victoria, 830  
 Penard (E.), Flagellates, 228  
 Penfold (A. R.), Some Essential Oils from *Leptospermum liverysidei*, 300; The Essential Oil from *Backhousia myrtifolia*. Part i., 468; The Essential Oils of two Myrtaceous Shrubs, *Homoranthus virgatus* and *H. flavescens*, 896; The Essential Oils of two Varieties of *Leptospermum flavescens*, 759; The Isolation and Identification of the Acid Bodies produced by the Oxidation of Piperitone by Means of Potassium Permanganate, 236; and F. R. Morrison, A New Stereoptene (probably a Phenol Ether) occurring in some Essential Oils of the Myrtaceae, 300  
 Penzer (N. M.), The Mineral Resources of Burma, 74; The Tin Resources of the British Empire, 5  
 Pereira (Gen. Sir George), Journey from Peking to India, 852  
 Péringuey (Dr.), Bantu Throwing-stones and Brass, 494  
 Perkins (H. A.), The Resistance of Thin Electrified Conducting Layers, 436  
 Perot (A.), A Rapid Method of determining the Elements of Terrestrial Magnetism, 795  
 Perrett (Dr. W.), The Mechanism of the Cochlea, 633  
 Perrier (A.) and B. de Mandrot, The Elasticity and Symmetry of Quartz at High Temperatures, 655  
 Perrot (Prof. E.), presented with the Hanbury Medal of the Pharmaceutical Society, 554  
 Perucca (E.), The Surface Properties of Mercury: Voltaic Character, Surface Tension, Photo-electric Effect, 623  
 Petavel (Capt. J. W.), Co-operation and the Problem of Unemployment, 298  
 Petersen (Dr. C. G. J.), The Fauna of the Sea-bottom, 527  
 Petrie (Prof. W. M. Flinders), The Green Ray at Sunset and Sunrise, 604  
 Petronievics (Dr. B.), Jurassic Birds, 261  
 Pexton (S.), awarded a Gas Research Fellowship in Leeds University, 98  
 Pézard (A.), The Idea of the "seuil différentiel" and Humoral Interpretation of the Gynandromorphism of the Bipartite Birds, 64; The Idea of the "seuil différentiel" and Progressive Masculinisation of Certain Female Birds, 299; and F. Caridroit, Sex-linked Heredity in the Gallinaceae, 796  
 Phisalix (Dr. Marie), Animaux venimeux et venins. Tome premier et tome second, 691; The Hedgehog and Virus of Rabies, 796  
 Piaggio (Prof. H. T. H.), Space-time Geodesics, 699; Summary of the Theory of Relativity, 432  
 Picard (E.), Discours et mélanges, 629  
 Pick (W. H.), Visibility as a Sign of Coming Rain, 713  
 Pickering (Prof. W. H.), Mars, 427  
 Pickworth (A.), The Corrosion of Ferrous Metals, 83  
 Picon (M.), The Action of Sodammonium on Hexamethylenetetramine, etc., 686  
 Pilling (G. F.), appointed Assistant Lecturer and Demonstrator in Agriculture in Leeds University, 621  
 Pippard (Dr. A. J. S.), appointed Professor of Engineering at the University College of South Wales and Monmouthshire, 562  
 Pittard (Prof. E.), Recent Investigations of the Lake Dwellings of Switzerland, 12  
 Planck (Prof. Max), Einführung in die Theorie der Elektrizität und des Magnetismus. Zum Gebrauch bei Vorträgen, sowie zum Selbstunterricht, 474; Vorlesungen über Thermodynamik. Sechste Auflage, 207; The Development of German Science, 750  
 Plaskett (Dr. J. S.), A Very Massive Star, 364; and others, The Radial Velocities of 594 Stars, 95  
 Platt (R.), appointed Demonstrator in Pathology and Bacteriology in Sheffield University, 562  
 Plimmer (Violet G.) and Prof. R. H. A. Plimmer, Vitamins and the Choice of Food, 336  
 Pogson (W.), The Establishment of the Kodaikanal Observatory, 711  
 Pogue (J. E.), The Economics of Petroleum, 474  
 Poireé (J.), Précis d'arithmétique, 445  
 Poivilliers (M.), A New "Stereo-autograph," 723  
 Poliard (A.), The Mechanism of Working of the Adipose Cells, 623  
 Pollard (Prof. A.), Action of Cutting Tools, 875  
 Pollock (Prof. J. A.), [obituary article], 359  
 Pons and Rémy, The Reddish-brown Coloration shown in March 1922 by the Briançon Snow, 28  
 Poole (H. E.), Switching and Switchgear, 805  
 Poole (Dr. H. H.),  $\alpha$ -Particles as Detonators, 148; The Detonating Action of  $\alpha$ -Particles, 830  
 Pope (Amy E.), Pope's Manual of Nursing Procedure, 445  
 Pope (Sir William), elected President of the International Union of Pure and Applied Chemistry, 126, 197  
 Popesco (J. G.), The Relation between Photo-electric Phenomena and the Surface Tension of Mercury, 299; The Variation of the Surface Tension of Mercury in Gases, 268  
 Porter (Prof. A. W.), The Green Ray at Sunset and Sunrise, 513; and J. J. Hodges, The Law of the Distribution of Particles in Colloidal Suspensions with Special Reference to Perrin's Investigations, 135  
 Porter (Dr. E. C.), appointed Demonstrator in the Department of Leather Industries of Leeds University, 621  
 Portier (P.) and M. Duval, Osmotic Pressure of the Blood of the "Wiped" Eel as a Function of Modifications of the Salinity of the External Medium, 864; Variation of the Osmotic Pressure of the Blood of the Cartilaginous Fishes, etc., 28; The Variation of the Osmotic Pressure of the Blood of the Eel as a Function of Modifications of the Salinity of the External Medium, 332  
 Potter (Prof. M. C.), Wart Disease of Potatoes, 563  
 Potts (F. A.), reappointed Demonstrator of Comparative Anatomy in Cambridge University, 530  
 Pouissote and Lautier, Child Sacrifice at Carthage, 322  
 Powell (H. J.), Modern Developments in the Making of Stained and Painted Glass, 687; [obituary article], 742  
 Powers (W. L.) and T. A. H. Teeter, Land Drainage, 211  
 Prescott (F. C.), The Poetic Mind, 443  
 Preston (F. W.), Comparison of the Structure of Sand-blasted and Ground Glass Surfaces, 591; Structure of Abraded Glass Surfaces, 162  
 Price (Dr. T. Slater), Gelatin, 286; The Desensitising of Silver Bromide-Gelatin Plates, 849  
 Priestley (A. H.), appointed Lecturer in Bacteriology in Leeds University, 720  
 Priestley (G.), appointed Assistant Lecturer in Cloth Analysis in Leeds University, 720  
 Priestley (Prof.) and others, Absorption of Water by Root and Stem Tips, 786  
 Priestley (R. E.), elected a Fellow of Clare College, Cambridge, 620  
 Prior (Dr. G. T.), The Meteoric Iron of Karee Kloof, etc., 757  
 Procopius (S.), The Variations in the Arc Spectrum of Mercury with the Conditions of Emission, 299  
 Punnett (Prof. R. C.), awarded the Darwin Medal of the Royal Society, 674, 787; and P. G. Bailey, Genetic Studies in Rabbits: I. Inheritance of Weight, 463; Inheritance of Weight in Poultry, 463  
 Purvis (J. E.) and T. R. Hodgson, The Chemical Examination of Water, Sewage, Foods, and other Substances. Second edition, 571  
 Pycraft (W. P.), The Nebraska Tooth, 707  
 Quayle (E. T.), Rain-producing Influences in South Australia, 586  
 Quayle (P. P.), Photography of Bullets in Flight, 514  
 Quennell (M. and C. H. B.), Everyday Life in the Old Stone Age, 443



- R. (S.), A Curious Luminous Phenomenon, 481  
 Rabe (W.), The System of Castor, 189  
 Radcliffe (W.), Fishing from the Earliest Times, 534  
 Raman (Prof. C. V.), Molecular Elotropy in Liquids, 11;  
 Molecular Diffraction of Light, 505; Opalescence  
 Phenomena in Liquid Mixtures, 77; The Spectrum  
 of Neutral Helium, 700; Transparency of Liquids  
 and Colour of the Sea, 280  
 Ramanathan (K. R.), The Molecular Scattering of Light  
 in Vapours, etc., 655  
 Ramsay (the late Sir William), The Memorial to, in  
 Westminster Abbey, 636  
 Rankine (Prof. A. O.), The Origin of Magnetism, 616;  
 X-ray Electrons, 681  
 Ransome (Dr. A.), [death], 225; [obituary article], 256  
 Rasmussen (K.), Researches in Baffin Land and the  
 Hudson Bay Region, 643; Work in Melville Peninsula  
 and Fox Basin, 18  
 Rassow (Prof. B.), The Centenary Celebrations of the  
 Society of German Men of Science and Physicians, 750  
 Rateau (Prof. A.), General Theory of the Turbo-compressor  
 for Aviation Motors, 63; Rapid High-altitude  
 Flying, 41  
 Raven (Sir Vincent), The Electric Locomotive, 41  
 Ray (R. C.), Heat of Crystallisation of Quartz, 62  
 Ray (Satyendra), Some Significant Relations in the  
 Quantum Theory of Spectra, 215  
 Rayleigh (Lord), Polarisation of the Light scattered by  
 Mercury Vapour near the Resonance Periodicity,  
 654; Spectrum of the Night Sky, 769  
 Rayner (M. C.), Calluna "Cuttings," 794  
 Read (Sir Hercules), Far Eastern Archaeology, 161  
 Reading (A. A.), Volcanic Activity in Nigeria, 97  
 Recoura (A.), Some New Properties of the Green Sulphate  
 of Chromium, 28  
 Redgrove (H. S.) and I. M. L. Redgrove, Joseph Glanvill  
 and Psychical Research in the Seventeenth Century,  
 36  
 Reed (Dr. F. R. Cowper), Devonian Fossils from Chitral  
 and the Pamirs, 291; The Geology of the British  
 Empire, 5  
 Reeves (J.), The World-story of 3,000,000,000 (?) Years,  
 443  
 Rehn (J. A. G.), Dermaptera and Blattidæ of the Transvaal  
 and Natal, 822  
 Reichenbach (H.), G. Cerf, E. Globot, and Richardson-  
 Foy, Einstein's Theories, 398  
 Reid (Sir G. Archdall), Medical Education, 769  
 Reinach (T.), The Statue of Sophocles in the Lateran  
 Museum, 494  
 Rendle (Dr. A. B.), Seedlings of Horse-chestnut from  
 which the Terminal Bud had been removed by  
 cutting through the Epicotyledonary Stem, 26  
 Rettger (Prof. L. F.) and H. A. Cheplin, A Treatise on  
 the Transformation of the Intestinal Flora, with  
 Special Reference to the Implantation of Bacillus  
 Acidophilus, 694  
 Reyburn (Prof. H. A.), The Ethical Theory of Hegel:  
 a Study of the Philosophy of Right, 70  
 de Reynold (Prof.), The Condition of Intellectual Life  
 in Austria, 755  
 Reynolds (F. D.), appointed Osborne Reynolds Fellow  
 in Manchester University, 653  
 Reynolds (J. H.), Transcription of Russian Names, 635  
 Rhodes (R. C.), The Stagers of Shakespeare, 36  
 Richards (H.), New Weights and Measurements for  
 India, 734  
 Richardson (E. C.), International Co-operation in Intel-  
 lectual Work, 883  
 Richardson (E. G.), The Theory of the Singing Flame, 829  
 Richardson (L. F.), Weather Prediction by Numerical  
 Process; Forms whereon to write the Numerical  
 Calculations described in "Weather Prediction by  
 Numerical Process," 762; A. Wagner and R. Dietzius,  
 an Observational Test of the Geostrophic Approxima-  
 tion in the Stratosphere, 27  
 Richardson (W. A.), The Frequency-distribution of  
 Igneous Rocks in relation to Petrogenic Theories,  
 756  
 Richmond (B.), conferment upon, of an honorary degree  
 by Leeds University, 561  
 Rickett (Prof. Ch.), translated by Dr. J. N. y López, Die  
 Anaphylaxie, 694; and Mme. A. G. Le Ber, Studies  
 on Lactic Fermentation, 863  
 Ridgeway (Sir William), Cambridge and the Royal  
 Commission, 689, 873  
 Riesenfeld (Prof. E. H.), The Preparation and Properties  
 of Pure Ozone, 615  
 Rinne (Prof. F.), Das feinbauliche Wesen der Materie  
 nach dem Vorbilde der Kristalle, 2 und 3 Auflage, 839  
 Riou (P.), The Velocity of Absorption of Carbon Dioxide  
 by Ammoniacal Solutions, 591  
 Ripon (the Bishop of), conferment upon, of an honorary  
 degree by Leeds University, 561  
 Rishbeth (O. H. T.), Water-supply in Central Australia,  
 822  
 Ritchie (Dr. J.), appointed an additional member of the  
 Committee to advise the Secretary for Scotland  
 respecting the Wild Birds Protection Acts, 461;  
 Naturalisation of Animals and Plants, 868  
 Ritchie (Dr. W.), appointed Assistant Lecturer in Biology  
 at Bradford Technical College, 233  
 Rivers (the late Dr. W. H. R.), Plea for Closer Co-operation  
 between Scientific Societies, 493; and others, The  
 Relations between Sentiments and Complexes, 231  
 Robb (Dr. A. A.), Relativity and Physical Reality, 572;  
 Space-time Geodesics, 809  
 Roberts (Dr. Fl.) and T. R. Parsons reappointed Demon-  
 strators in Physiology in Cambridge University, 530  
 Robertson (Dr. G. Scott), Basic Slags and Rock Phosphates,  
 306  
 Robertson (Sir Robert), elected President of the Faraday  
 Society, 784  
 Robinson (Dr. J. H.), The Humanising of Knowledge, 298  
 Robinson (R. L.), Forestry Practice and Available Timber  
 Supplies throughout the Empire, 159  
 Rockefeller, jr. (J. D.), gift to the American Museum of  
 Natural History, 126  
 Rodier (W.), The Rat Problem, 612  
 Roe-Thompson (E. R.), Wegener's Displacement Theory,  
 214  
 Roger (E.), The Periodic Return of Severe Winters, 863  
 Rogers (Dr. A.), Practical Tanning, partly based on the  
 third edition of "Practical Tanning," by L. A.  
 Flemming, 840  
 Rogers (A. F.), Collophane, 292  
 Rogers (Dr. A. W.), The Geology of the Country around  
 Heidelberg; Geological Map of the Country around  
 Heidelberg, 662  
 Rogers (R. A. P.), The Time-triangle and Time-triad  
 in Special Relativity, 698  
 Rohr (Dr. M. von), rendered into English by Dr. A. H.  
 Levy, Eyes and Spectacles, 376  
 Romieu (M.), A Method of Selective Coloration of the  
 Nervous System in some Invertebrates, 532; and  
 F. Obaton, Comparative Spectroscopic Study of the  
 Green Pigment of the Chetoptera and the Chlorophyll  
 of the Green Alga, *Ulva lactuca*, 200  
 Roper (R. E.), The Individual and the Community, 340  
 Roscoe (Rev. J.), Twenty-five Years in East Africa, 56  
 Rosenhan (Dr. W.) and J. D. Grogan, The Effects of  
 Over-heating and Melting on Aluminium, 500  
 Rosny aîné (J.-H.), Les Sciences et le Pluralisme, 541  
 Ross (Sir Ronald), Discoveries in Tropical Medicine, 38  
 Rouch (J.), Le Pôle Sud: Histoire des voyages antarctiques,  
 540  
 Rouch (Prof. J.), Manuel d'océanographie physique, 840  
 Roughton (F. J. W.), awarded the Gedge Prize of Cam-  
 bridge University, 590  
 Rougier (Prof. L.), Authorised Translation by Prof. M.  
 Masius, Philosophy and the New Physics: an Essay  
 on the Relativity Theory and the Theory of Quanta,  
 568  
 Roussille (H.), Results obtained in 1921 and 1922 by the  
 Application of Aerial Photography to Precision  
 Plans on the Large Scale, 831  
 Rowell (H. S.), Action of Cutting Tools, 413, 771; Animal  
 Mechanism, 542; The Elliptic Logarithmic Spiral,  
 214  
 Rowley (F. R.), Ouramœba, 40  
 Rübel (Prof. E.), Geobotanische Untersuchungsmethoden,  
 208

- Rubens (Prof. H.), [obituary articles], 740 and 741  
 Rueff (J.), Theory of the Phenomena of Exchange, 863  
 Rushworth (G. M.N.), The Painted Glass of Gloucester Cathedral, 585  
 Russell (Dr. A. S.), An Introduction to the Chemistry of Radio-active Substances, 477  
 Russell (E. S.), The Work of the Fisheries Laboratory at Lowestoft, 757  
 Russell (G. H. H.), appointed an honorary clinical tutor in Dental Surgery in Leeds University, 621  
 Russell (Prof. H. N.), Dark Nebulae, 81; presented with the Draper Gold Medal of the National Academy of Sciences of the U.S.A., 820  
 Russell (Sir John), The History of British Agriculture, 204  
 Rutherford (Sir Ernest), awarded the Copley Medal of the Royal Society, 674, 787; Electricity and Matter, 182  
 Rutnan (Prof. R. F.), Some Aspects of Scientific and Industrial Research, 130  
 Ryland (H. S.), Colour Vision and Syntony, 668
- S. (T. R. R.), The Miraculous Draught of Fishes, 665  
 Sabine (Prof. P. E.), Research Work on Acoustics, 575  
 Sacerdote (P.) and P. Lambert, A New Method for Detecting the Presence of a Submarine, 299  
 Saint (S. J.), appointed Assistant Lecturer in Agriculture in Leeds University, 621  
 Salaman (Dr.), Address to the Potato Conference, 884  
 Salet (P.), The Law of Dispersion of Prismatic Spectra in the Ultra-violet, 895  
 Salisbury (Dr. E. J.), The Methods of Ecological Investigation, 208  
 Salmon (Dr. E. H.), Columns: A Treatise on the Strength and Design of Compression Members, 210  
 Salomonson (Prof. J. K. A. W.), [obituary], 552  
 Sampson (H. C.), Prairie Vegetation in Illinois, 823  
 Sampson (Prof. R. A.), presented with the Keith Prize of the Royal Society of Edinburgh, 19  
 Sanfourche (A.), The Reactions between the Gaseous Oxides of Nitrogen and Alkaline Solutions, 591  
 Satô (M.), "Electrets," the Analogues of Magnets, 714  
 Saunders (Miss E. R.), two cuckoos reared together in the same nest, 160  
 Sauvage (Prof. E.), Feed-water Heaters for Locomotives, 41  
 Savage (Dr. W. G.), Methods used for the Inspection of Canned Foods, 366; R. F. Hanwicke and R. B. Calder, Bacteriology of Canned Meat and Fish, 614  
 Schafer (Sir E. Sharpey), elected President of the International Physiological Congress, 711; presented with the Neill Prize of the Royal Society of Edinburgh, 19; presentation to, 882  
 Schanz (Dr. F.), A New Theory of Vision, 557  
 Schaumasse (A.), Observations of the Baade Comet made at Nice Observatory, 723; Observations of the Skjellerup Comet (1922d) made with the Equatorial of Nice Observatory, 895  
 Schidrowitz (Dr. P.), Recent Progress in Rubber Chemistry and Technology, 726  
 Schilowsky (P.), Some Applications of the Gyroscope, 829  
 Schlich (Sir William), Schlich's Manual of Forestry. Vol. 1.: Forest Policy in the British Empire. Fourth edition, 407  
 Schlick (Prof.), The Philosophical Importance of the Theory of Relativity, 750  
 Schmidt (Dr. Johs.), Live Specimens of Spirula, 788; The Life History of the Eel, 716  
 Schoneboom (C. G.), Diffusion and Intertraction, 62  
 Schramm (Dr. J. R.), The Abstracting and Indexing of Biological Literature, 745  
 Schubert (A.), The Semi-Diesel Engine, 191  
 Schuster (Sir Arthur), The Acoustics of Enclosed Spaces, 247, 341; The Green Flash at Sunset, 370  
 Schwartz (B.), Philippine Cattle Round-worm, 823  
 Schweitzer (Prof. A.), translated by C. T. Campion, On the Edge of the Primeval Forest: Experiences and Observations of a Doctor in Equatorial Africa, 308  
 Scott (Dr. D. H.), The Early History of the Land Flora, 606, 638
- Scott (H. H.) and C. Lord, Turbinoid Bones of *Notothium Mitchellii*, 228  
 Scott (J. W. R.), The Foundations of Japan: Notes made during Journeys of 6000 Miles in the Rural Districts as a Basis for a Sounder Knowledge of the Japanese People, 538  
 Scott (Dr. W. E.), The Prehistoric Relations between Spain and Ireland, 228  
 Scripture (Prof. E. W.), Physical Nature of Verse, 494  
 Seagrave (F. E.), Pons-Winnecke's Comet, 712  
 Sears (Prof. G. W.), A Systematic Qualitative Chemical Analysis: a Theoretical and Practical Study of Analytical Reactions of the more Common Ions of Inorganic Substances, 477  
 See (Prof. T. J. J.), The Sunspot Periodicity, 525  
 Seely (Maj.-Gen. J. E. B.), Presidential Address to the Congress of the Royal Sanitary Institute, 232  
 Seigle (M.), The Possibilities of the Commercial Use of Mild Steel Bars hardened by Extension, 623; The Principal Characteristics of Mild Steel Bars previously broken by Traction, 591  
 Selbie (C. M.) and Dr. S. W. Kemp, British and Irish Paguridea, 191  
 Seligman (R.) and P. Williams, Cleaning Aluminium Utensils, 500  
 Sellars (Prof. R. W.), Evolutionary Naturalism, 631  
 Senter (Dr. G.), elected to the Senate of London University, 562; selected as candidate for the vacancy in the representation of Science Graduates on the Senate of London University, 233  
 Seward (Prof. A. C.), Palaeobotany and Earth-history, 585; and W. French, the state of the tombstone of the grave of Sir Richard Owen's parents, 611; and J. Walton, A Collection of Fossil Plants from the Falkland Islands, 861  
 Shafer (R.), Progress and Science: Essays in Criticism, 662  
 Shain (G.), The Meteors of the Pons-Winnecke Comet, 678  
 Shakespear (Dr. G. A.), instrument for measuring differences in composition of similar gas mixtures, 615  
 Shand (Dr. S. J.), The Origin of Igneous Rocks rich in Alkalies, 323  
 Shann (E. W.), First Lessons in Practical Biology, 601, 736  
 Shann (G.), The Evolution of Knowledge, 471  
 Shapley (Prof. H.), The Distance of the Cepheid Variables, 645; The Galactic System, 545, 578; and Miss A. J. Cannon, Distribution of Stars of same Spectral Class, 854  
 Sharp (Dr. D.), [death], 361; [obituary article], 521  
 Shaw (A. E.), New Australasian Blattidæ, with a note on the Blattid Coxa, 500  
 Shaw (Sir Napier), Meteorological Theory in Practice, 762; The Weather Map: an Introduction to Modern Meteorology. Fifth Issue (reprint of Fourth), 768; Transmission of Sound of Explosions, 415  
 Shear (Dr. L.), Coins of Croesus, 54  
 Sheppard (T.), elected President of the Museums Association for 1924, 163; Harpoons under Peat in Holderness, Yorks, 735; The Hull Municipal Museum, 291  
 Sherborn (C. D.), Index Animalium. Sectio secunda 1801-1850. Part 1, 3  
 Sherman (Prof. H. C.) and S. L. Smith, The Vitamins, 6  
 Sherrington (Sir C. S.), Some Aspects of Animal Mechanism, 346; The Foulerton Studentship, 787; The Use of a Pancreatic Extract in Diabetes, 774  
 Shield (A. M.), bequest to the Cambridge Medical School, 621  
 Shipley (Sir Arthur), *Furia infernalis*, 27  
 Shirley (J.) and C. A. Lambert, *Coprosma Baueri*, End., 168  
 Shuttleworth (Dr. G. E.) and Dr. W. A. Potts, Mentally Deficient Children: Their Treatment and Training. Fifth edition, 663  
 Sidebotham (E. J.), appointed Honorary Lecturer in Public Health in Manchester University, 653  
 Sievers (E. G.), Carbon-black in the United States, 397; Natural Gas Gasoline in 1920, 791  
 Silberrad (C. A.), The Weights and Measures of India, 325, 735  
 Silberstein (Dr. L.), Some Spectrum Lines of Neutral Helium derived theoretically, 247, 248

- Silvester (N. L.), an unusual Scabious, 188  
 Simmons (A. T.) and A. J. V. Gale, A First Book of General Science: an Introduction to the Scientific Study of Animal and Plant Life, 406  
 Simon (E. D.) and Marion Fitzgerald, The Smokeless City, 269  
 Simon (L. J.), Oxidation by Mixtures of Sulphuric Acid and Chromates, 168; The Chromic Oxidation of the Homologues of Acetic Acid, 268; The Direct Oxidation by Oxygen or Air of the Esters of the Alcohol Acids, 592; The Influence of the Structure of Organic Compounds on their Oxidation by Chromic and Sulphuric Acids, 863; and A. J. A. Guillaumin, The Quantitative Determination of Carbon and of Hydrogen by the use of Chromic and Sulphuric Acids, 623; and L. Zivy, The Neutralisation of Tartaric Acid by Potash in Presence of the Chlorides of the Alkaline Earths, 655  
 Simpson (Dr. G. C.), One Possible Cause for Atmospheric Electric Phenomena: a Reply, 604  
 Simpson (Prof. S.), The Body Temperature of Birds, 566  
 Sinclair (Prof. W. J.), American Oligocene Mammals, 888; Entelodonts from the Oligocene of South Dakota, 21; The "Turtle-Oreodon Layer" in S. Dakota, 128  
 Singer (Dr. C.), Greek Biology and Greek Medicine, 631; The Discovery of the Circulation of the Blood, 602; The Earliest Drawings made by Means of the Microscope, 829  
 Sirks (Dr. M. J.), Handboek der Algemeene Erfelijkheidsleer, 111; on the review of, 394  
 Skene (Dr. M.), Common Plants, 177  
 Slipher (E. C.), Mars, 428  
 Smillie (Dr. W. G.), Studies on Hookworm Infection in Brazil, 1918-20, 169  
 Smith (Prof. Alexander), [obituary article], 457  
 Smith (A. J.), appointed University Frank Smart Student in Botany in Cambridge University, 530  
 Smith (Dr. C. F.), The Testing of Transformers and Alternating Current Machines, 805  
 Smith (C. J.), The Viscosity and Molecular Dimensions of Hydrogen Selenide, 758  
 Smith (Prof. C. Michie), [death], 491; [obituary article], 610  
 Smith (Col. D. J.), The Design of Motor Cars, 644  
 Smith (E. A.), resignation of the Secretaryship of the Non-ferrous Metals Research Association, 321  
 Smith (Eng.-Capt. E. C.), Scientific and Industrial Pioneers, 846  
 Smith (Maj.-Gen. Sir Frederick), Veterinary Anatomy in England during the 16th, 17th and 18th Centuries, 296  
 Smith (F. E.), awarded the John Winbolt Prize in Cambridge University, 530  
 Smith (H. G.), awarded the David Syme Research Prize of Melbourne University, 259; Occurrence of Lævo-phellandrene in the Oil of *Melaleuca acuminata*, 759; The Chemistry of certain Australian Plant Products. Part i., 895  
 Smith (H. M.), Gaseous Exchange and Physiological Requirements for Level and Grade Walking, 728  
 Smith (Prof. J. G.), Organised Produce Markets, 404  
 Smith (Dr. Kirstine), The Standard Deviation of a Co-efficient of Correlation, 827  
 Smith (K. M.), Mosaic Disease in Plants, 668; and J. C. M. Gardner, Insect Pests of the Horticulturalist: Their Nature and Control. Vol. i.: Onion, Carrot, and Celery Flies, 694  
 Smith (Sir Ross), 14,000 Miles through the Air, 631  
 Smith (S. P.), [obituary article], 187  
 Smith (T.), A Large Aperture Aplanatic Lens not corrected for Colour, 895; The Optical Cosine Law, 895  
 Smith (W. B.), Smokeless Methods in Glasgow Housing Schemes, 232  
 Smith (Dr. W. D.), Petroleum in the Philippines, 21  
 Smithells (Prof. A.), impending retirement of, 641; recognition of the services of, by the Court of Leeds University, 893  
 Smith-Rose and Barfield, Effect of Local Conditions on Radio Direction-finding, 753  
 Smyth (H. D.), A New Method for Studying Ionizing Potentials, 654  
 Snodgrass (R. T.) and V. F. Camp, Radio Receiving for Beginners, 411  
 Soddy (Prof. F.), awarded the Nobel Prize for Chemistry for 1921, 674  
 Solvay (E.), [obituary article], 84  
 Somerville (Rear-Admiral B. T.), The Date of Stonehenge, 429  
 Sommerfeld (Prof. A.), to lecture in the University of Wisconsin in 1922-23, 368  
 Sommerville (D. M. V.), Division of Space by Congruent Triangles and Tetrahedra, 862  
 Sonnefeld (Dr. A.), Telescopes versus Field Glasses, 202  
 Spärck (Dr. R.), The Conditions of Sex-change in the Oyster (*Ostrea-edulis*), 480  
 Spath (Dr. L. F.), The Cretaceous Marine Transgression in the African Region, 291  
 Speller (F. N.), The Corrosion of Ferrous Metals, 84  
 Spence (Dr. J.), award to, by the Carnegie Hero Fund, 524  
 Spiro (Prof.), The Electrolyte and the Organism, 751  
 Sprague (T. A.), The Identification of *Sison Annini*, Linn., 27; Twin-leaves and other Abnormalities in the Common Ash, *Fraxinus excelsior*, 757  
 Springer (F.), *Balanocrinus mexicanus*, n.sp., 262  
 Sprott (W. J. H.), appointed Demonstrator in Experimental Psychology in Cambridge University, 561  
 Stanton (Dr. T. E.), The Characteristics of Cylindrical Journal Lubrication at High Values of the Eccentricity, 794  
 Starling (Prof. E. H.), appointed to the Foulerton Professorship, 787  
 Starling (S. G.), Electricity, 176  
 Steavenson (Dr. W. H.), Skjellerup's Comet, 1922b, 20  
 Steel (T.), Chemical Notes: General, 759  
 Steiner (P.), The Ultra-violet Absorption Spectra of the Alkaloids of the Isoquinoline Group, 895  
 Stekel (Dr. W.), Translated by R. Gabler, The Beloved Ego: Foundations of the New Study of the Psyche, 805  
 Stephen (K.), The Misuse of Mind: a Study of Bergson's Attack on Intellectualism, 541  
 Stephenson (Dr. J.), Some Scottish Oligochaeta, with a note on Encystment in a Common Freshwater Oligochaete, *Lambriculus variegatus* (Müll.), 723; The Pharyngeal Glands of the Microdrili (Oligochaeta), 100  
 Stephenson (L. W.), New Radiolites, 261  
 Stephenson (T. A.), appointed Assistant in the Department of Zoology and Comparative Anatomy at University College, London, 435  
 Steuart (D. W.), The Unappreciable Matter of Fats, 894  
 Stevens (Miss Catharine O.), Telescopic Observation of Atmospheric Turbulence, 280  
 Steward (G. C.), elected to a Fellowship at Gonville and Caius College, 684  
 Stewart (J. Q.), An Electrical Analogue of the Vocal Organs, 311  
 Stewart (L. M.), A Coincidence in Values, 279  
 Stiles (Prof. W.), The Preservation of Food by Freezing with special reference to Fish and Meat, 101  
 Stillman (Prof. J. M.), Theophrastus Bombastus von Hohenheim, called Paracelsus: His Personality and Influence as Physician, Chemist, and Reformer, 202  
 Stockdale (D.), The Copper-rich Aluminium-copper Alloys, 499  
 Stocks (J. L.), Aristotle's De Caelo, 174  
 Stokes (Prof. A.), appointed Dunn Professor of Pathology at Guy's Hospital Medical School, 105  
 Stoklasa (J.), The Respiration of the Roots, 831  
 Stone (E. H.), The Age of Stonehenge, 291  
 Stone (H.), A Guide to the Identification of our more Useful Timbers: being a Manual for the Use of Students of Forestry, 276; A Text-book of Wood, 73  
 Stone (H. E.), a large specimen of *Datura Stramonium*, 525  
 Stoneley (R.), appointed Curator of the Sheffield University Observatory, 684  
 Stopes (Dr. Marie C.), Constructive Birth Control, 612  
 Störmer (Prof. C.), Auroral Measurements, 162  
 Storrow (B.), The Herring Fishery and its Fluctuations, 705  
 Strachan (J.), The Microscope in Paper-making, 99

- Strasser (Prof. H.), Die Grundlagen der einstein'schen Relativitätstheorie: Eine kritische Untersuchung, 568
- Stratton (Dr. S. W.), elected President of the Massachusetts Institute of Technology, 641
- Straus (Dr. F.), appointed Professor of Chemistry at the Breslau Technische Hochschule, 720
- Sturley (Dr. A. A.), [death], 674
- Sudeley (Lord), [obituary article], 851
- Sumner (F. B.) and R. R. Huestis, Bilateral Symmetry in its Relation to certain Problems of Genetics, 463
- Sussmich (C. A.), elected President of the Royal Society of N.S.W., 126
- Sutton (J. R.), The Control of Evaporation by the Temperature of the Air, 64; The Propagation of Heat in Water, 832
- Swann (H. Kirke), A Synopsis of the Accipitres (Diurnal Birds of Prey). Parts 1, 2, 3. Second edition, 339
- Swanton (E. W.), Defoliation of Oaks, 250
- Swanton (I. R.), The Creek Indians, 646
- Swift (H. W.), appointed Demonstrator in Engineering in Leeds University, 621
- Swindells (Rev. B. G.), Kalocsa Observations of Prominences, 678
- Swindin (N.), Pumping in the Chemical Works, 726; The Flow of Liquids in Pipes, 726
- Swinton (A. H.), Ancient Observations of Aurora, 785
- Symons (H. W.), appointed a Clinical Assistant in Surgery in Leeds University, 133
- Szilard (B.), A New Electrometer with Rigid Pointer designed for the Measurement of Radiations, 136; The Direct Estimation of very small Quantities of Radium by the Penetrating Rays, 168.
- Tabor (R. J.), A New Fungal Disease of Cacao and Coffee, 794
- Taggart (W. Scott), Cotton Spinning. Vol. ii. Sixth edition with Appendix, 75
- Takamine (Dr. J.), [obituary], 361
- Tasker (R. B.), appointed Honorary Demonstrator in Anatomy for Dental Students and an Honorary Clinical Tutor in Dental Surgery in Leeds University, 621
- Tawney (C. H.), [obituary], 225
- Taylor (Dr. Griffith), Distribution of Future White Settlement, 526
- Taylor (G. I.), The Motion of a Sphere in a rotating Liquid, 62
- Taylor (J. K.), A Chemical and Bacteriological Study of a Typical Wheat Soil of N.S.W., 300
- Taylor (Dr. Monica), Water Snails and Liver Flukes, 701
- Taylor (W. T.), Electric Power Systems, 506; High Voltage Power Transformers, 506
- Taylor (Wilson), Capillarity, 377
- Tedley (C. F.), conferment upon, of an honorary degree by Leeds University, 561
- Teichert (Dr. K.), Die chemische Analyse. VIII.-IX. Bände: Methoden zur Untersuchung von Milch und Molkeerzeugnissen, 110
- Telford (E. D.), appointed Professor of Systematic Surgery in Manchester University, 26
- Temple (Bishop), Symbolism as a Basis for Metaphysics, 231
- Terroine (E. F.) and H. Barthélemy, Avitaminosis and Imanition, 687; and R. Wurmser, The Utilisation of Ternary Substances in the Growth of *Aspergillus niger*, 299
- Thiébaud (M.), The Composition of the Iridescent Marls, 532
- Thoday (Prof. D.), appointed Professor of Botany at the University College of North Wales, Bangor, 60
- Thom, jr. (W. T.), The Rocky Mountain Oil-field, 714
- Thomas (H. L.), Extraction of Radiolaria from Oozes, 216
- Thomas (Dr. J. S. G.), A Recording and Integrating Gas Calorimeter, 251
- Thompson (C. J. S.), The History of "Hiera Picra," 296
- Thompson (F. C.) and E. Whitehead, The Changes in Iron and Steel at Temperatures below 280° C., 794
- Thompson (Prof. McLean), Flower Structure in the Lecythidaceae, 614
- Thompson (R. R.), elected Professor of Petroleum-mining in Birmingham University, 590
- Thompson (T. W.), Gypsy Folklore, 556
- Thomson (A. D.), bequest to Minnesota University, 166
- Thomson (Hon. G. M.), The Naturalisation of Animals and Plants in New Zealand, 868; and the late T. Anderton, Work of the Marine Biological Station and Fish Hatchery, Portobello, N.Z., 266
- Thomson (G. P.), appointed Professor of Natural Philosophy in Aberdeen University, 399; The Scattering of Hydrogen Positive Rays and the Existence of a Powerful Field of Force in the Hydrogen Molecule, 654
- Thomson (Sir Joseph J.), presented with the Franklin Gold Medal of the Franklin Institute, 188
- Thorpe (Prof. J. F.), awarded the Davy Medal of the Royal Society, 674, 787
- Thorpe (Sir T. Edward), A Dictionary of Applied Chemistry. Vol. 3. Revised and enlarged edition, 305; Prof. G. Lemoine, 850; Paracelsus, 202
- Thoulet (Prof. J.), L'Océanographie, 541
- Tian (A.), Thermostats with Multiple Jackets, 27
- Tilby (A. W.), The Evolution of Consciousness, 147, 279
- Tilden (Sir William) and others, The Teaching of Science in Schools and Colleges, 754
- Tilley (C. E.), The Petrology of the Metamorphosed Rocks of the Start Area (South Devon), 167
- Tillyard (Dr. R. J.), Life-history of *Ithone fusca*, 495; Mesozoic Insects of Queensland. No. 9, 864; Some New Permian Insects from Belmont, N.S.W., in the Collection of Mr. John Mitchell, 300
- Timbie (Prof. W. H.) and Prof. V. Bush, Principles of Electrical Engineering, 506
- Tischler (Prof. G.), Handbuch der Pflanzenanatomie: Allgemeine Pflanzenkaryologie, 176
- Topley (W. W. C.), appointed Professor of Bacteriology in Manchester University, 134
- Tovey (S. R.) and P. F. Morris, Contributions from the National Herbarium of Victoria. No. 2, 332
- Towler (E. E.), An Empire Patent, 772
- Trélease (Prof. W.), Plant Materials of Decorative Gardening: the Woody Plants. Second edition, 177
- Trillat (A.), The Influence of Humidity and Vesicular State on the Diffusion in Air of Drops containing Micro-organisms, 332
- Trivelli (A. P. H.), F. L. Righter, and S. E. Sheppard, Photographic Experiments, 397
- Troland (L. T.), Psychophysics as the Key to the Mysteries of Physics and Metaphysics, 24
- Trouton (Prof. F. T.), [death], 459; [obituary article], 490
- Troxell (E. L.) and others, American Vertebrate Palaeontology, 585
- Truffaut (G.) and N. Bezssonoff, A New Bacillus capable of fixing Nitrogen, 623
- Tschugaeff (Prof. L.), [death], 781
- Tudsbury (Dr. J. H.), elected an Honorary Member of the Royal Dutch Institute of Engineers, 188
- Tupman (Lt.-Col. G. L.), [obituary article], 742
- Turnbull (H. W.), Double Binary Forms, 862
- Turner (A. J.), Australian Lepidoptera, 168; Revision of Australian Lepidoptera: Saturniadae, Bombycidae, Eupterotidae, Notodontidae, 759; Some Australian Moths from Lord Howe Island, 864
- Turner (Prof. H. H.), Focal Depths of Earthquakes, 55
- Turner (S.), The Conquest of the New Zealand Alps, 872
- Turner (Prof. W. E. S.), The British Glass Industry, 833; The Glass Industry and Methods of Manufacture in Czecho-Slovakia, 830; The Mixing of Batch, 63; and others, Glass Research, 430
- Tutton (Dr. A. E. H.), Crystallography and Practical Crystal Measurement. Second edition. In 2 vols., 303; Pasteur in Crystallography. Supplement (Dec. 23), viii; Rotary Polarisation of Light, 809; Ten Years of X-ray Crystal Analysis, 47
- Tweedie (C.), James Stirling: A Sketch of his Life and Works along with his Scientific Correspondence, 111
- Tye (L. M.), Illuminating Engineering in Relation to the Architect, 746
- Underhill (Dr. J.), Mineral Land Surveying. Third edition, 541

- Unstead (Dr. J. F.), appointed Professor of Geography in the University of London, 198; The Belt of Political Change in Europe, 529
- Urban (Prof.), elected an Honorary Member of the Royal Institution, 784
- Urquhart (J. W.), Steel Thermal Treatment, 837
- Uvarov (B. P.), Grasshoppers of the Genus *Hieroglyphus* and their nearest Allies, 822
- Van Buskirk (E. F.) and E. L. Smith, The Science of Everyday Life, 406
- Vaney (C.) and J. Pelosse, Origin of the Natural Coloration of the Silk of *Bombyx mori*, 64
- Varignon (F.), Bicentenary of the death of, 782
- Varley (T.), Hampshire, 339
- Vaulk (Dr. R. de la), Recent Work on Intersexuality, 54
- Vavon (G.) and A. Husson, Catalysis by Platinum Black, 299
- Vayson (A.), The Development of Flint Implements, 128
- Veal (T. H. P.), appointed Assistant Lecturer in Civil Engineering in Birmingham University, 368
- Verdier (J. W.), Statistics of Shipping Casualties and Loss of Life at Sea, 51
- Vernadsky (Prof. W.), Chemical Composition of the Earth's Crust, 229; Nickel and Cobalt in the Biosphere, 436; The Problem of the Decomposition of Kaolin by Organisms, 532
- Vernet (G.), The Role of Calcium Chloride in the Coagulation of the Latex of *Hevea Brasiliensis*, 686
- Vila (M.), Separation of the Globulins of Horse Serum, 687
- Vilmorin (J. de) and Cazaubon, The Catalogue of Seeds, 200
- Vincent (G. E.), Work of the Rockefeller Foundation for 1921, 52
- Vincent (Prof. Swale), Internal Secretion and the Ductless Glands. Second edition, 658
- Vines (Dr. H. W. K.), awarded the Raymond Horton-Smith Prize of Cambridge University, 828
- de Virville (A. D.) and F. Obaton, Observations and Experiments on Ephemeral Flowers, 655; The Opening and Closing of Persistent Meteoric Flowers, 759
- Visger (Mrs. J. A. Owen), [obituary article], 257
- Visher (Dr. S. S.), Tropical Cyclones in Southern Hemisphere, 647
- Vuillemin (P.), Disjunction and Combination of the Characters of the Parents in a Hybrid, 436
- Voicu (J.), The Influence of Humus on the Sensibility of *Azotobacter Chroococcum* towards Boron, 332
- Volonakis (Dr. M. D.), The Island of Roses and her Eleven Sisters: or, the Dodecanese from the Earliest Time down to the Present Day, 146
- Vournazos (A. Ch.), Mixed Complex Anti-mercuriodibromides, 268
- Vulliamy (C. E.), A Long Barrow in Breconshire, 614
- Wade (E. B. H.), Improved River Discharge Measurements, 495
- Wagstaff (J. E. P.), elected to a Fellowship at St. John's College, Cambridge, 684
- Wait (W. E.) and others, Birds and some Invertebrates of Ceylon, 228
- Wakefield (Miss E. M.), Fungus-hunting in the West Indies, 563
- Walcott (Dr. C. D.), Geological Explorations in the Canadian Rocky Mountains, 18; The New Building of the National Academy of Sciences, U.S.A., 120
- Wales (Prince of), conferment of the Honorary Degree of LL.D. of St. Andrews University upon the, 498; presented with the Gold Medal of the Ramsay Memorial Fund, 745
- Walker (Dr. G. T.), Periodicities, 511; The Probable Amount of the Monsoon Rainfall in 1922, 159
- Walker (J. E.) and R. B. Foster, Patents for Inventions, 663
- Wall (Col. F.), Ophidia Toprobanica, or the Snakes of Ceylon, 538
- Wall (Dr. T. F.), A New Type of Electrical Condenser, 810, 885
- Wallace (R. Hedger), Vegetable Rennet, 543; Water Snails and Liver Flukes, 845
- Waller (Mrs. A. D.), [obituary article], 708
- Walmesley (W. A.), Tar Distillation, 130
- Walston (Waldstein) (Sir Charles), Harmonism and Conscious Evolution, 443
- Walter (L. H.), [death], 459
- Walton (Lt.-Col. H. J.), Mosquito Control, 838
- Walton (J.), appointed Junior Demonstrator of Botany in Cambridge University, 530
- Ward (J.), [obituary article], 49
- Ward (Prof. R. De C.), Precipitation in the United States, 366
- Waring (H. J.), elected Vice-Chancellor of the University of London, 25
- Warman (W. H.), Agricultural Co-operation in England and Wales, 404
- Warren (Dr. C. H.), appointed Director of the Sheffield Scientific School, Yale University, 60
- Warren (Dr. E.), Inheritance in the Foxglove, 827
- Warren (Prof. H. C.), A History of the Association Psychology, 75
- Warren (S. H.), The Red Crag Flints of Foxhall, 54
- Warth (A. F.), Colour Observations of the Moon, 605
- Washburn (Prof. E. W.), An Introduction to the Principles of Physical Chemistry from the Standpoint of Modern Atomistics and Thermodynamics. Second edition, 305
- Waterhouse (Major-Gen. J.), [death], 491; [obituary article], 552
- Watkins (A.), Early British Trackways, Moats, Mounds, Camps, and Sites, 176
- Watson (J. A. S.), appointed Professor of Agriculture and Rural Economy in Edinburgh University, 133
- Watson (W.), Textile Design and Colour: Elementary Weaves and Figured Fabrics. Second edition, with an Appendix on Standard Yarns, Weaves, and Fabrics, 74
- Watt (R. A. Watson), The Origin of Atmospherics, 680
- Watts (J. I.), Ernest Solvay, 84
- Weaver (Prof. J. E.), F. C. Jean, and J. W. Crist, Development and Activities of Roots of Crop Plants, 887
- Weaver (Sir Lawrence), impending retirement from the Post of Second Secretary and Director-general of Land Settlement of the Ministry of Agriculture, 461
- Webb (R. W.), Germination of the Spores of certain Fungi in Relation to Hydrogen-ion Concentration, 128
- Weber (Prof. Max), Celebration of Seventieth Birthday, 780
- Webster (Prof. A. G.), Absolute Measurement of Sound, 42
- Wedderburn (Dr. E. M.), appointed Professor of Conveyancing in the University of Edinburgh, 198
- Wegener (Dr. A.), Die Entstehung der Kontinente und Ozeane. Dritte Auflage, 798
- Wegmann (E.), The Design and Construction of Dams: including Masonry, Earth, Rockfill, Timber, and Steel Structures, also the Principal Types of Movable Dams. Seventh edition, 661
- Weiss (Prof.), The Origin of Magnetism, 616
- Welch (M. B.), Occurrence of Oil-glands in the Barks of certain Eucalypts, 759; Relationship between Oil-glands and Oil Yields in the Eucalyptus, 592
- Wells (H. G.), Acceptance of Labour Candidature for Member of Parliament for the University of London, 166; adopted as Parliamentary Candidate for London University by the University Labour Party, 530; A Short History of the World, 867
- Wells (S. H.), retirement of, 134
- Welsh (E. R.), Waterspouts and Centrifugal Force, 644
- Wendt (Dr.) and Dr. Irion, The Decomposition of Tungsten, 520
- Werner (Miss A.), More Light on the Bantu Languages, 67
- Werth (Prof. E.), Der fossile Mensch: Grundzüge einer Paläanthropologie. Erster Teil, 508
- Wesley (W. H.), [death], 583; [obituary article], 609
- West (C. J.) and H. Gilman, Organomagnesium Compounds in Synthetic Chemistry, 853
- Weston (S.), A Constant Bubble, 895
- Wetherell (E. W.), The Track of a Flat Solid Falling through Water, 845

- Wetmore (A.), A Study of the Body Temperature of Birds, 566; Birds from Haitian Caves, 855; Owl from the Eocene of Wyoming, 190
- Wheeler (Prof. W. M.), A Study of some Social Beetles in British Guiana and of their Relations to the Ant-Plant *Tachigalia*, 98
- Wherry (E. T.), The Statement of Crystal-symmetry, 586
- Whiddington (Prof. R.), X-ray Electrons, 681
- Whitaker (W.), The Water Supply of Cambridgeshire, Huntingdonshire, and Rutland from Underground Sources, 7
- White (E. G.), The Voice Beautiful in Speech and Song: A Consideration of the Capabilities of the Vocal Cords and their Work in the Art of Tone Production. Third edition, 871
- Whitehead (Prof. A. N.), elected President of the Aristotelian Society, 126; presented with the James Scott Prize of the Royal Society of Edinburgh, 50; The Relatedness of Nature, 63; Uniformity and Contingency, 756; and Prof. H. Wildon Carr, The Philosophical Aspects of the Principle of Relativity, 231
- Whiteley (B.), Iron-founding, 537
- Whiteley (J. H.), The Effect of Deformation on the Ar 1 Change in Steels, 682
- Whitney (P. C.), An Experimental Towing-tank used by Benjamin Franklin, 10
- Whittaker (Prof. E. T.), elected a Foreign Member of the Reale Accademia dei Lincei, Rome, 188; Quantum Mechanism in the Atom, 23
- Wieland (Prof.), appointed to the Editorial Board of *Liebig's Annalen*, 554
- Wightman (E. P.), A. P. H. Trivelli, and S. E. Sheppard, Studies in Photographic Sensitivity, 714
- Wightman (W. A.), appointed Demonstrator in Organic Chemistry in Leeds University, 621
- Wilckens (Dr. O.), Upper Cretaceous Gastropods of New Zealand, 556
- Wilkins (V. E.), Agricultural Research and the Farmer: A Record of Recent Achievement, 93
- Wilkinson (Dr. G.), The Mechanism of the Cochlea, 560, 737
- Williams (A. M.), Two Properties of Powders, 135
- Williams (C. B.), Sense of Smell in Birds, 149
- Williams (H.), The Lavas of Snowdonia, 888
- Williamson (H. B.), An Addition to the Flora of Victoria, 168; Revision of the Genus *Pultenea*. Part iii., 563
- Willis (Dr. A. R.), [obituary article], 86
- Willis (Dr. J. C.), Age and Area, 710; and others, The Present Position of Darwinism, 751
- Willoughby (C. C.) and E. A. Hooton, Earthworks in America, 585
- Wilson (Dr. R. W.), [death], 851
- Wilmott (A. J.), *Orchis latifolia* Linn. (marsh orchis) from the Island of Oland, Sweden, 757
- Wilson (C. B.), Parasitic Copepods, 54
- Wilson (C. T. R.), awarded a Royal Medal of the Royal Society, 674, 787; Some  $\alpha$ -ray Tracks, 861
- Wilson (Prof. G. H.), appointed Professor of Pathology in Birmingham University, 368
- Wilson (G. V.) and others, Special Reports on the Mineral Resources of Great Britain. Vol. 2: Barytes and Witherite, 211
- Wilson (Prof. J.), Variation of Milk Yield with the Cow's Age and the Length of the Lactation Period, 830
- Wilson (J. S.) and others, The Design of Railway Bridges, 825
- Wilson (R. M.), appointed Principal of the South-Eastern Agricultural College, 134
- Wilson (W.), The Quantum Theory and Electromagnetic Phenomena, 722
- Wilson-Smith (Miss M. J.), awarded the Lindley Studentship in the University of London for 1922, 25
- Winge (Dr. O.), Chromosomes of the "Millions" Fish, 748
- Winstedt (E. O.), English Gypsy Christian Names, 90
- Wirtz (C.), The Brightness and Rotation of Uranus, 747
- Wislicenus (Prof. W.), [death], 50; [obituary article], 223
- Witherby (H. F.) and W. L. Sclater, Birds marked in Europe recovered in South Africa, 323
- Wolbach (Prof. S. B.), New Growths and Cancer, 766
- Wolfe (W. S.), Graphical Analysis: A Text-book on Graphic Statics, 412
- Wollaston (T. R.), Filtration: An Elementary Treatise on Industrial Methods and Equipment for the Filtration of Liquids and Gases for those concerned with Water Supply, Ventilation, and Public Health; Chemists, Mechanical Engineers, and others, 663
- Wollman (E.) and M. Vagliano, The Influence of Avitaminosis on Lactation, 136
- Wood Comet, 1922 *a*, 555; 1922 *d*, 785
- Woodger (J. H.), appointed University Reader in Biology at Middlesex Hospital Medical School, 25
- Woodward (A. M.), A Decorative Bronze Silenus Mask found at Ilkley, 748
- Woodward (B. B.), Giantism among Gastropods, 128
- Wootton (Mrs. Barbara), Sex Economics, 533
- Wray (D. A.), The Geology and Mineral Resources of the Serb-Croat-Slovene State: Being the Report of the Geologist attached to the British Economic Mission to Serbia, 33
- Wren (Sir Christopher), the Bi-centenary of the death of, 226
- Wright (C. E.), The Elliptic Logarithmic Spiral, 40
- Wright (C. S.), Gravity Variations, 875
- Wright (Prof.), Leonardo da Vinci's Work on the Structure of the Heart, 296
- Wright (W. B.), Geology and the Nebular Theory, 76
- Wrightson (F. B.), awarded the J. S. Fry and Sons, Ltd., Colston Research Fellowship in the University of Bristol, 25
- Wrinch (Dr. Dorothy) and Dr. H. Jeffreys, The Variable Depth of Earthquake Foci, 310
- Wurmser (Mlle.), The Preparation of Ammonium Nitrate, 28
- Wybergh (W. J.), Coal in South Africa, 786
- Yabe (Prof. H.) and S. Hanzawa, Uhlgina, a New Type of Foraminifera found in the Eocene of Japan and West Galicia, 749
- Yokoyama (Prof. M.), Japanese Pliocene Fossils, 646
- Yorke (J. Paley), Magnetism and Electricity. New edition, 630; Technical Education, 24
- Young (Miss J. M.), Periodical Comets, 89
- Young (Prof. K.), Immigrant Groups in America, 713
- Young (Prof. S.), Azeotropic Mixtures, 758
- Young (Prof. W. H.), elected President of the London Mathematical Society, 711
- Younghusband (Sir Francis), presented with the Charles P. Daly Medal of the American Geographical Society, 158
- Youngman (W.), Germination of Indian Barley, 585
- Yovanovitch (D.), The Chemical Properties of Mesothorium-2, 332; and Mlle. Chamie, The Preparation of a Standard Radium Salt, 290
- Yule (G. U.), elected to a fellowship at St. John's College, Cambridge, 684
- Zeeman (Prof. P.), awarded the Rumford Medal of the Royal Society, 674, 787; elected a Corresponding Member of the Prussian Academy of Sciences, Berlin, 158
- Zivy (R.), An Unpublished Method of Preparing Vaccine, 687

TITLE INDEX.

- $\alpha$ -particles: and Atomic Nuclei, The Shocks between, P. Auger and F. Perrin, 400; as Detonators, Dr. H. H. Poole, 148; The Detonating Action of, Dr. H. H. Poole, 830
- $\alpha$ -ray Photographs, The Analysis of, P. M. S. Blackett, 721; Tracks, Some, C. T. R. Wilson, 861
- $\alpha$ - and  $\beta$ -rays, The Theory of the Scattering of, Dr. J. H. Jeans, 721
- Aberdeen University: Conferment of degrees, 133; G. P. Thomson appointed Professor of Natural Philosophy, 399; Dr. A. W. Gibb appointed Kilgour Professor of Geology, 754
- Aberwraich, Tests for the Utilisation of Tidal Power at, 492
- Absorption of Water by Root and Stem Tips, Prof. Priestley and others, 786
- A.C. High Tension Transmission Lines, The Electrical Design of, H. H. Jeffcott, 167
- Acacia Seedlings, Part viii., R. H. Cambage, 592
- Acipitres (Diurnal Birds of Prey), A Synopsis of the Parts 1, 2, and 3, H. Kirke Swann. Second edition, 339
- Acids, The Manufacture of, during the War, Prof. T. M. Lowry, 777
- Acoustic Research, 565; Prof. T. Lyman, 773
- Acoustics: American Research on, A. E. Munby; Prof. P. E. Sabine, 575; of Enclosed Spaces, The, Sir Arthur Schuster, 247, 341
- Actinometer, An, with Electrodes of Mercury, G. Athanasia, 299
- Adhesives, E. Hatschek, 528; Research Committee, First Report of the, 528
- Adipose Cells, Mechanism of Working of the, A. Policard, 623
- Adolescent Girl, The Care of the: a Book for Teachers, Parents, and Guardians, Dr. Phyllis Blanchard, 411
- Adsorbed Films, Density of, R. M. Deeley, 313
- Advisory Council to the Committee of the Privy Council for Scientific and Industrial Research, Eng. Vice-Admiral Sir George Goodwin and Dr. J. C. Irvine appointed members of the, 321
- Aeration and Air Content: the Rôle of Oxygen in Root Activity, F. E. Clements, 58
- Aerial Photography, Results obtained in 1921 and 1922 by the Application of, to Precision Plans on the Large Scale, H. Roussilhe, 831
- Aeroplane Performance Calculations, H. Booth, 110
- Aesthetics, 443; The Foundations of, C. K. Ogden, I. A. Richards, and J. Wood, 375
- Afforestation, State, The Progress of, 369
- After-image, Positive, The Movement of the, Dr. F. W. Edridge-Green, 772
- "Age and Area," Dr. J. C. Willis, 710; Index of a Population, The, Prof. R. Pearl and T. J. Le Blanc, 687
- Agricultural: Co-operation in England and Wales, W. H. Warman, 404; Industry, The Proper Position of the Landowner in relation to the, Lord Bledisloe, 392; Progress in Western India, G. Keatinge, 442; Research: and the Farmer: a Record of Recent Achievement, V. E. Wilkins, 93; in Great Britain, 93
- Agriculture: British, A Short History of, J. Orr, 204; The History of, Sir John Russell, 204; Effect of Post-war Conditions on, J. McClare Clark, 743; Ministry of, Educational Work of the, 398; Second Secretary and Director-General of Land Settlement at the, Resignation of Sir Lawrence Weaver of the post of, 461; and Industrial Fluctuations, Weather Cycles in relation to, Sir William Beveridge and others, 889; in India, Position of, Dr. B. A. Keen, 442
- Air, Exploration of: Out of the World North of Nigeria, A. Buchanan, 35
- Air: 14,000 Miles through the, Sir Ross Smith, 631; as a Cooling Agent, The Use of, M. Leblanc, 63
- Alcohol: Acids, The Direct Oxidation by Oxygen or Air of the Esters of the, L. J. Simon, 592; Commercial Absolute, A Method for the Preparation of, and its Application to the Preparation of a National Motor Fuel C. Mariller and Van Ruymbeke, 623; Power, its Production and Utilisation, G. W. Monier-Williams, 172; as a Beverage in its relation to certain Social Problems, Prof. Mellanby and others, 294; as a Fuel, 172
- Aldebaran, Occultation of, 613
- Aldehydes and Ketones, The Hydrogenation of, in the Presence of Pure and Impure Platinum Black, M. Failslein, 863
- Algemeene Erfelijkheidssleer, Handboek der, Dr. M. J. Sirks, 111
- Algerian Tribes, Folklore among the, M. W. Hilton-Simpson, 161
- Algol Variable, An Interesting, A. H. Joy, 461
- Alkaline Carbonates, The Estimation of, in Presence of Phenolphthalein, M. Bonnier, 723
- Alkaloids of the Isoquinoline Group, The Ultra-violet Absorption Spectra of the, P. Steiner, 895
- Alkyl-glycerols, The, R. Delaby, 805
- Aluminium: Alloys of, The Constitution and Age-hardening of, with Copper, Magnesium, and Silicon in the Solid State, Marie L. V. Gayler, 499; -copper Alloys, The Copper-rich, D. Stockdale, 499; Experiments on the Oxide Method of determining, J. E. Clennell, 499; The Effects of Over-heating and Melting on, Dr. W. Rosenhain and J. D. Grogan, 500; Utensils, Cleaning, R. Seligman and P. Williams, 500
- Ameghino, Florentino, Obras completas y correspondencia científica de, vol. 3, 540
- America: Broadcasting in, A. P. M. Fleming, 294; Immigrant Groups in, Prof. K. Young, 713
- American: Biological Societies, a Federation of, Proposed Formation of, 394, 582; British and, Fine Chemicals, 653; Council on Education, The Work of the, 330; Cretaceous Dinosaurs, W. D. Mathew and B. Brown, 21; Dyestuff Industry, The, 426; Ethnology, Thirty-fifth Annual Report of the Bureau of, 1913-1914. In 2 Parts. Part 2, 176; Museum of Natural History, Gifts to, by J. D. Rockefeller, Jr., and G. F. Baker, 126, 880; Oligocene Mammals, W. J. Sinclair, 888; Research on Acoustics, A. E. Munby; Prof. P. E. Sabine, 575; Universities, Relative Support given to the Arts and the Sciences in the Graduate Schools of, 234; Vertebrate Palæontology, E. L. Troxell and others, 585
- Americanists, The International Congress of, at Rio de Janeiro, 523
- Ammoniacal: Liquor Stills, The Design of, P. Parrish, 130; Silver Fluoride, Dervin and Olmer, 863
- Ammonium Nitrate, The Preparation of, Mlle. Wurmser, 28
- Amundsen Expedition, The, 87
- Analysis, General, Generalised Limits in, C. N. Moore, 687
- Anaphylaxie, Die, Prof. Ch. Richet. Translated by Dr. J. Negrin y López, 694
- Andaman Islanders, The: a Study in Social Anthropology, A. R. Brown, 106; concerning the review of, A. R. Brown, 554
- Andes, The Physiology of Life in the, J. Barcroft, 152
- Anellaria separata* growing in the Alps, S. Hastings, 563
- Animal: and Vegetable Pathology in relation to Human Disease, Profs. Hobday and Lang, 293; Associations of some Crustacea, Dr. S. Kemp, 888; Mechanism, 333; Some Aspects of, Sir C. S. Sherrington, 346; H. S. Rowell, 542
- Animals: and Plants: in New Zealand, The Naturalisation of, Hon. G. M. Thomson, 868; Dr. J. Ritchie, 868; Diseases of, Collected Leaflets on, 427
- Animaux venimeux et venins, Dr. Marie Phisalix, Tome Premier et Tome Second, 691
- Annelids of Iceland and the Faroes, The, Rev. H. Friend, 342
- Annual Register, The, 1921, 75
- Antarctic: Lands, Geology of, D. Ferguson and others, 96; Wintering in the, T. W. Bagshawe and M. C. Lester, 50
- Anthrax in Stock in Australia, Incidence of, M. Henry, 236

Anthropology in the Chiltern Hills, W. Bradbrooks and Prof. F. G. Parsons, 526  
 Anticyclones, The Cause of, W. H. Dines, 845  
 Anti-moniobromides, Mixed Complex, A. Ch. Vournazos, 268  
 Antimony: -bismuth System, The, M. Cook, 531; The Isotopes of, Dr. F. W. Aston, 732  
 Ants in relation to Plants, J. Bequaert, 822  
 Aplanatic Lens, A Large Aperture not corrected for Colour, T. Smith, 895  
 Arab Art in America, G. B. Gordon, 429  
 Arabic Chemistry, E. J. Holmyard, 573  
 Arc Spectrum of Mercury, The Variations in the, with the Conditions of Emission, S. Procopiu, 299  
 Archaeology: Far-Eastern, Sir Hercules Read, 161; The Year's Work in, 523  
 Arctic: Foraminifera, 241; Rotifera, H. K. Haring, 55 Area, The Dimensions of, Dr. N. R. Campbell, 9  
 Argonauts of the Western Pacific: an Account of Native Enterprise and Adventure in the Archipelagoes of Melanesian New Guinea, Dr. B. Malinowski, 472  
 Aristotelian Society, Prof. A. N. Whitehead elected President of the, 126  
 Aristotle: in English, 174; The Works of, translated into English. De Caelo, J. L. Stocks; De Generatione et Corruptione, Prof. H. H. Joachim, 174  
 d'Arithmétique, Précis, J. Poireé, 445  
 Arsenical Glucoside, An, A. Aubry and E. Dormoy, 759  
 Artificial Limbs and Amputation Stumps: a Practical Handbook, E. M. Little, 805  
 Asia: Central, Fossil Vertebrates in, Prof. H. F. Osborn, 646; The Peopling of, Dr. A. Hrdlička, 54  
 Asiatic Society and the Discovery of the Secret of the Egyptian Hieroglyphs, Centenary of the, 125  
*Aspergillus niger*, The Utilisation of Ternary Substances in the Growth of, E. F. Terroine and R. Wurmser, 299  
 Asphalt and Related Bitumens in 1921 in the U.S., 749  
 Association Psychology, A History of the, Prof. H. C. Warren, 75  
 Astacocroton, a New Type of Acarid, Prof. W. A. Haswell, 759  
 Asteroids, Origin of the, Dr. K. Hirayama, 53

#### ASTRONOMICAL NOTES.

Comets:  
 Skjellerup's Comet, 1922 (*b*), 20, 53, 89; Periodical Comets, Miss J. M. Young, 89; Skjellerup's Comet, G. Merton, 160; Perturbations of Wolf's Comet, M. Kamensky, 290, 525; Comets, 555; A New Comet, Dr. Baade, 584; Comets, Mdle. V. Hansen; M. Kasakov, 613; Comets, 785  
 Instruments:  
 The Frye Reflecting Telescope, 364  
 Meteors:  
 Large Fireball on July 26, 189; August Meteors, 364; September Meteors, 395; October Meteor Showers, 493; Recent Meteors, W. F. Denning, 613; Possible Recurrence of a Meteor Shower, 747; Large Fireballs, W. F. Denning, 821; Great Meteor of December 6, 886  
 Observatories:  
 Norman Lockyer Observatory (1921-1922), Report by Dr. W. J. S. Lockyer, 53; The Paris Observatory, 127; Cambridge University Observatory, 127; Harvard College Observatory, 127; The Dominion Astrophysical Observatory, Victoria, 189  
 Planets:  
 Origin of the Asteroids, Dr. K. Hirayama, 53; Roche's Limit for Satellites, Dr. E. O. Fountain, 89; Observations of Mars at Sétif, Algeria, R. Jarry-Desloges, 160; Conjunction of Venus and Jupiter, 260; The Orbital Distances of Satellites and Minor Planets, Prof. G. Arceellini, 260; Mars, M. Maggini; Dr. Fountain, 364; Mars, E. C. Slipper; Prof. W. H. Pickering, 428; Mercury visible as a Morning Star, 555; Variability in the Light of Iris, 584; The Brightness and Rotation of Uranus, C. Wirtz, 747  
 Stars:  
 Prof. Plaskett's Massive Star, 53; The System of Castor, W. Rabe, 189; Variable Stars near M. 53, Dr. Baade, 364; Abbreviations of Constellations'

Names, 364; New Nebulae, D. H. Menzel, 364; A Very Massive Star, Dr. J. S. Plaskett, 364; Absolute Magnitudes of Stars, Dr. H. D. Curtis, 395; The Orbit of Sirius, C. P. Howard; An Interesting Algeid Variable, A. H. Joy, 461; Parallaxes of 22 Cepheids, Dr. S. A. Mitchell, 493; Nova T Coronae (1866), K. Lundmark, 493; The Masses of Visual Binary Stars, J. A. Miller and J. H. Pitman, 555; Spectroscopic Parallaxes for Type A, Adams and Joy, 584; Globular Clusters in the Large Magellanic Cloud, 584; Occultation of Aldebaran, 613; A Bright New Star, 785; The Reported Nova in Lyra, Dr. A. C. D. Crommelin, 821; The Mass and Proper Motion of 40 Eridani, Prof. G. Abetti, 854; The Distribution of Stars of same Spectral Class, Dr. H. Shapley and Miss A. J. Cannon, 854; Stellar Temperatures and Planetary Radiation, Dr. W. W. Coblenz, 886; Spectroscopic Parallaxes of B Stars, D. L. Edwards, 886

Sun:  
 Solar Atmospheric Changes, Dr. W. J. S. Lockyer; A. M. Newbegin; C. P. Butler, 20; Invisible Sunspots, Dr. G. E. Hale, 395; The Law of Solar Rotation, Dr. Halm, 428; Sunspots in High Latitude, 428; The Sunspot Periodicity, Prof. T. J. J. See, 525

Miscellaneous:  
 The Paris Astrographic Catalogue, J. Baillaud, 160; The Problem of Three Bodies, 290; Flamsteed's Letters to Richard Towneley, 525; Calendar Reform, C. F. Marion, 747; Misconceptions about Relativity, 747; Publications of the Astronomical Society of the Pacific, 785; Ancient Observations of Aurora, A. H. Swinton, 785; Relativity and Space, Rev. H. V. Gill, 854

Astronomical Society of the Pacific, Publications of the, October, 785

Astronomie, Histoire de l', E. Doublet, 600  
 Astronomy: History of, 600; The Elements of, Prof. D. N. Mallik, 731; The New, 2  
 Athletics and Oxygen Supply, Prof. A. V. Hill, 588  
 Atlantic: Hurricanes, 324; Vertical Circulation in the, A. Merz and G. Wüst, 262  
 Atmosphere, The Standard, W. R. Gregg, 366  
 Atmospheric: Electric Phenomena, One Possible Cause for: a Query, Sir Oliver Lodge, 512; a Reply, Dr. G. C. Simpson, 604; Electricity, 406; Turbulence, Telescopic Observation of, Miss Catharine O. Stevens, 280  
 Atmospherics: New Radiogoniometric Observations of, J. Lacoste, 686; The Origin of, R. A. Watson Watt, 680  
 Atom, Within the: a Popular View of Electrons and Quanta, J. Mills, 246  
 Atomic: Model, An, with Stationary Electrons, Dr. H. S. Allen, 310; Models of Bohr and of Lewis and Langmuir, A Possible Reconciliation of the, W. Hughes, 37  
 Atoms: and Electrons, R. N. Pease, 379; and Elements, Periodic Structure of, H. N. Allen, 415; of Matter, The: their Size, Number, and Construction, Dr. F. W. Aston, 702  
 Aucubine, The Presence of, and of Melampyrite (dulcité) in several Species of Melampyrum, Mlle. Marie Braecke, 831  
 Audition: Resonance Theories of, Some Cases of Nerve-deafness and their Bearing on, J. P. Minton, 563; The Resonance Theory of, Prof. E. H. Barton, 316  
*Aurelia aurita*, The Mode of Feeding of the Jelly-fish, on the Smaller Organisms in the Plankton, Dr. J. H. Orton, 178  
 Aurora, Ancient Observations of, A. H. Swinton, 785  
 Auroral Measurements, Prof. C. Störmer, 162  
 Australasian Blattide, New, with a Note on the Blattid Coxa, A. E. Shaw, 500  
 Australia: Gravity Determinations in, E. F. J. Love, 563; New Gall-thrips from, A Remarkable, H. H. Karny, 500; Railway Problems in, Prof. T. Hudson Beare, 354; The Lorantheaceae, Part iii, W. F. Blakely, 759  
 Australian: Asilidae (Diptera) in the National Museum, G. H. Hardy, 168; Grasses, The Nutritive Value of Certain, Margaret H. O'Dwyer, 759; Lepidoptera,



- Revision of, A. J. Turner, 759; Plant Products, The Chemistry of Certain, Part i., H. G. Smith, 895; *Science Abstracts*, Impending Publication of, 259; Tabanidae, Notes on, Part ii., E. W. Ferguson and G. F. Hill, 500; Termites, A New, G. F. Hill, 500
- Austria: The Condition of Intellectual Life in, Prof. de Reynold, 755, 792
- Auto-oxidation, C. Moureu and C. Dufraisse, 268
- Aveline's Hole, An Upper Palaeolithic Station, 54
- Avian Minstrelsy, 209
- Aviation, S. P. Langley's Pioneer Work in, Prof. L. Baird-stow, 637
- Avitaminosis: The Influence of, on Lactation, E. Wollman and M. Vagliano, 136; and Inanition, E. F. Terroine and H. Barthélemy, 687
- Azeotropic Mixtures, Prof. S. Young, 758
- Azotobacter Chroococcum*, The Influence of Humus on the Sensibility of, towards Boron, J. Voicu, 332
- Baede Comet, Observations of the, M. Giacobini; A. Schuamasse, 723
- Bacillus diphtheriae*, The Protective Action of Normal Serum in Experimental Infection with, T. J. Mackie, 236
- Bachousia myrtifolia*, The Essential Oil from, Part i., A. R. Penfold, 468
- Bacteria, Culture of, in a Medium of Definite Chemical Composition, with Pyruvic Acid as a Base, R. Cambier and E. Aubel, 200
- Bacteriolytic Element found in Tissues and Secretions, A. Fleming and V. D. Allison, 686
- Bacteriophage, The Theory of, Dr. F. d'Herelle, 293
- Bangalore, Indian Institute of Science, 649
- Bangor, University College of North Wales, Prof. D. Thoday appointed Professor of Botany at the, 60
- Bantu: and Semi-Bantu Languages, A Comparative Study of the, Sir Harry H. Johnston. Vol. 2, 67; Languages, More Light on the, Miss A. Werner, 67; Throwing-stones and Brass, Dr. Périnquey, 494
- Bantuland, In the Heart of, D. Campbell, 246
- Barcelona, Underground Railways in Course of Construction in, 290
- Barium Chloroplatinate, The Dissociation of, G. Gire, 168
- Bark Canker Disease of Apple caused by *Myxosporium corticolaum*, Miss G. Gilchrist, 794
- Basic Slags and Rock Phosphates, Dr. G. Scott Robertson, 306
- Batch, The Mixing of, Prof. W. E. S. Turner, 63
- Batteries, A Particular Class of, V. Karper; P. Janet, 235
- Battersea Polytechnic, Calendar of, 368
- Bayer 205, Prof. Mayer, 751
- Beaufort Therapsida, Some Upper, S. H. Haughton, 236
- Bedford, A History of the County of. Part 1: Geology and Palaeontology, 339
- Beerenberg of Jan Mayen, The Glacial System of the, P. L. Mercanton, 28
- Beit Memorial Fellowships, Junior, for Medical Research, Award of, 158
- Belfast, Queen's University: Dr. R. C. Gray appointed Lecturer in Physics in, 792; Bequest by H. Musgrave, 828
- Belgium, New, L. Fredericq, 864
- Benson Aerological Observatory, Retirement of W. H. Dines from the Directorship of the, 188
- Benzene Nucleus, Substitution in the, Recent Researches on, Prof. A. F. Holleman, 19
- Bergson and Einstein, Prof. H. Wildon Carr, 503
- Berlin University, Physical-Chemical Institute of, Prof. Bodenstein invited to succeed Prof. Nernst in the, 720
- Beryllium Sulphate, The Dissociation of, Mlle. G. Marchal, 299
- Binary Forms, Double, H. W. Turnbull, 862
- Biological: Literature, Abstracting and Indexing of, Dr. J. R. Schramm, 745; Station, A new, established at the Lake of Trasimeno, 258; Studies in Madeira, Dr. M. Grabham, 45
- Biologischen Arbeitsmethoden, Handbuch der, Herausgegeben von Prof. E. Abderhalden. Lief. 55, Abt. v., Teil 6, Heft 3, 509
- Biology, Practical, First Lessons in, E. W. Shann, 601, 736; The Reviewer, 737
- Biometric Studies, Dr. Kirstine Smith and others, 827
- Bird Census, A Second, Prof. J. B. Cleland, 236
- Birds: Jurassic, Dr. B. Petronievics, 261; marked in Europe recovered in South Africa, H. F. Witherby; W. L. Slater, 323; Mimicry among, G. T. Harris, 161; Scuse of Smell in, C. B. Williams, 149; Songs of the, Prof. W. Garstang, 209; the Bipartite, the Gynandromorphism of, The Idea of the "seuil différentiel" and Humoral Interpretation of, A. Pézard, 64; the Body Temperature of, A Study of, A. Wetmore; Prof. S. Simpson, 566; The Krophic Role of, as regards the Culicines, J. Legendre, 655
- Birmingham: A Third-century, 614; and Edgbaston Debating Society, Annual Meeting of the, G. A. Baker elected President, 554; University: Conferment of degrees; C. G. Payton appointed Demonstrator in Anatomy; A. W. Nuthall appointed Ingleby Lecturer for 1924, 60; Appointments in, 368, 684; The War Memorial of, 561; R. R. Thompson elected Professor of Petroleum-mining in, 590; Lectures on Town-planning at, 720; Dr. Dorothy Margaret Patrick appointed Assistant Lecturer in Physiology, 859
- Birth Control, Constructive, The Ideals and Present Position of, Dr. M. C. Stopes, 612
- Births of Eminent People, Seasonal Incidence of the, Dr. F. J. Allen, 40
- Bishop Museum: The Bernice Pauahi, 322; Fellowships, Award of, 288
- Blood: Circulation of the, The Discovery of the, Dr. C. Singer, 602; Relationships, Human, 738; and Sterility, Christopher Blayre; The Writer of the Article, 846; Transfusion, Dr. G. Keynes, 871; The Oxygen-dissociation Curve of, and its Thermo-dynamical Basis, Prof. A. V. Hill and W. E. L. Brown, 685
- Blood? Does Cyanic Acid exist in the, M. Nicloux and G. Welter, 168
- Bloomsbury, Dr. A. Morley Davies; T. L. Humberstone, 250; and the University of London, T. L. Humberstone, 150
- Boat which moves against the Wind using the Wind itself as Motive Power, A. Constantin, Joessel, and Daloz, 686
- Bohr and Langmuir Atoms, Sir Oliver Lodge, 341
- Bohr's Model of the Hydrogen Molecules and their Magnetic Susceptibility, Prof. K. Honda, 664
- Bombyx mori*, The Silk of, Origin of the Natural Coloration of, C. Vanev and J. Pelosse, 64
- Borg en Nadur, Malta, Excavations at, Miss Murray, 859
- Borneo, Among Primitive Peoples in: A Description of the Lives, Habits and Customs of the Piratical Head-hunters of North Borneo, I. H. Evans, 146
- Borough Polytechnic Institute, Prospectus of the, 368
- Boscovich and Modern Science, 870
- Botanic Society's Gardens, The Royal, 185
- Botanical: Equivalents, Dictionary of, French-English, German-English, Dr. E. Artschwager and E. M. Smiley, 177; Serials, New Japanese, 891
- Botany: Gardens of the James Allen's Girls' School, Dulwich, The, Dr. Lilian J. Clarke, 329; School Instruction in, 329; Dr. Lilian J. Clarke, 512; Systematic, 190
- Bottom-living Communities in the Sea, H. Bleagard, 887
- Brachiopoda, Fossil, Critical Research on, S. S. Buckman, 262
- Bradford Technical College: Prospectus of the, 199; Dr. W. Ritchie appointed Assistant Lecturer in Biology at, 233
- Brasses, The Hardness of the, F. W. Harris, 532
- Braun Tube, The New, 786
- Brazil, A Biological Expedition to, under Prof. C. Massart, 126
- Brazilian Climatology, 291
- Breconshire, A Long Barrow in, C. E. Vulliamy, 614
- Breslau Technische Hochschule, Dr. F. Straus appointed Professor of Chemistry at the, 720
- Brewing, Institute of, Researches of the, 51

- Brancon Snow, The Reddish-brown Coloration shown in March 1922 by the, Pons and Rémy, 28
- Bristol University: The Fry Colston Research Fellowship awarded to F. B. Wrightson, 25; J. Lineham awarded the Degree of Ph.D., 466; Gift to, by the Bristol Medico-Chirurgical Society, 620
- British: and American Fine Chemicals, 653; and Swiss Universities, Conference of, 399; Association: at Hull, 124, 345, 391; Programmes of the Sections, 263; Presidential Address, Sir C. S. Sherrington, 346; Summaries of Addresses of Presidents of Sections, 352; Addresses of 1922, The, 507; The, a Retrospect, 1831-1921, O. J. R. Howarth, 302; Prof. H. E. Armstrong, 341; Research Committees, 560; The Local Handbook of the, B. Hobson, 605; Committee on Training in Citizenship, Three Reports of the, 828; Broadcasting Company, The, 581; Cast Iron Research Association, Activities of the, 820; Empire, Geology and Tin Resources of the, 5; Labour, Replacement and Conciliation, 1914-21: Part 1, on Replacement, Co-ordinated and Revised by Miss L. Grier and Miss A. Ashley; Part 2, on Conciliation, Edited by A. W. Kirkaldy, 145; Medical Association, The Glasgow Meeting of the, 293; The Gold Medal presented to Sir T. Clifford Allbutt and Lt.-Col. A. Martin-Leake, and the Stewart Prize to Dr. J. C. McVail, 294; Measures, Metric and, 29; Museum (Natural History). British Antarctic ("Terra Nova") Expedition, 1910. Natural History Report, Zoology, Vol. 6, No. 2. Protozoa, Part 2: Foraminifera, E. Heron-Allen and A. Earland, 241; Catalogue of the Books, Manuscripts, Maps and Drawings in the, Vol. 6. Supplement: A-I, 540; Non-ferrous Metals Research Association, Resignation by E. A. Smith of the Secretaryship of the, 321; Work of the, 643; Oil Victory, A. S. Brooks, 401; Research Association for the Woollen and Worsted Industries, Awards of the, 234; Science, Ninety Years of, 302; Science Guild, The Journal of the, 19; Acceptance by the Marquess of Crewe of the Presidency of the, 611; Scientific Glass Industry, The, Prof. W. E. S. Turner, 833; West Africa, The Agricultural and Forest Products of, G. C. Dudgeon. Second edition, 210
- Brittle-stars, New Antarctic, Prof. R. Kochler, 713
- Broadcasting: in America, A. P. M. Fleming, 294; in Great Britain, 469; Licences, The Issue of, 553; Radio-telephony and, A. P. M. Fleming, 858
- Brooklyn Institute, Museums of the, Report of the, 676
- Browne, Sir Thomas, The Skull of, Sir Arthur Keith and Prof. Karl Pearson, 149
- Bryozoa, Two new Species of, W. M. Bale, 563
- Bubble, A Constant, S. Weston, 895
- Building Contracts: The Principles and Practice of their Administration, E. J. Evans, 110
- Bullets in Flight, Photography of, P. P. Quayle, 514
- Butyl: Alcohol, The Chlorination of Normal, H. Gault and R. Guillemet, 436; -ethyl-malonylurea, A New Hypnotic in the Barbituric Series, P. Carnot and M. Tiffeneau, 299
- "Cable Guide," C. A. Stevenson and the invention of the, Dr. C. G. Knott, 88
- Cacao and Coffee, A New Fungal Disease of, R. J. Tabor, 794
- Calcium: Cyanamide as a Manure, The Practical Conditions for Using, P. Mazé, 864; Phosphate and the Phosphates of Iron and Alumina, The Comparative Assimilability of, Ch. Brioux, 864; The Influence of, on the Utilisation of the Reserves during the Germination of Seeds, L. Maquenne and E. Demoussy, 299
- Calculus: Applied, An Introductory Text-book, F. F. P. Bisacre, 411; of Probabilities and of Mathematical Statistics, A Problem of the, B. Meidell, 758
- Calendar: A Proposed 13-Month, C. F. Marion, 747; of Industrial Pioneers, 61, 99, 135, 166, 199, 234, 267, 298, 331, 368, 400, 436, 467, 499, 531, 562, 591; 622, 654, 685, 721, 756, 793, 829, 861
- California, Cinozoic Fishes of, Prof. D. S. Jordan and J. Zaccheus, 397
- Calluna "Cuttings," M. C. Rayner, 794
- Cambridge: and the Royal Commission, 689; Sir William Ridgeway, 873; The Writer of the Article, 874; Advanced Mathematical Study and Research at, Prof. H. S. Carslaw, 8; Oxford and, Universities of, Bill, 201; University, F. Lavington and J. Line elected Fellows of Emmanuel College; J. A. Carroll elected Fellow of Sidney Sussex College, 25; W. B. R. King elected a Fellow and Lecturer in Natural Sciences at Magdalene College; P. M. S. Blackett elected Charles Kingsley Bye Fellow of Magdalene College; L. E. Bayliss elected Michael Foster Student in Physiology, 25; Conferment of Honorary Degrees, 60; Observatory, Report of the, 127; Prof. H. R. Dean appointed Professor of Pathology in, 368; Appointments in, 530, 590; Bequests to, by C. Jewell and Dr. W. H. R. Rivers; W. J. H. Sprott appointed Demonstrator in Experimental Psychology; J. C. Burkill and A. E. Ingham elected Fellows of Trinity College, 561; Appointments; Women Students and Degrees, 620; Request to the Medical School by A. M. Shield, 621; E. C. Francis elected Fellow and Mathematical Lecturer at Peterhouse; C. G. Lamb appointed Reader in Electrical Engineering; Allotment for the School of Biochemistry; A Studentship to be Founded under the Will of Sir John Sandys, 653; Solar Physics Observatory, Annual Report of the, 678; Elections in, 684; Proposed Creation of a Readership in Biochemistry, 720; Proposal to create a Lectureship in Crystallography for A. Hutchinson; The Admission of Women to the Titles of Degrees, 792; Dean Inge and Sir Sidney F. Harmer elected Honorary Fellows of King's College; K. P. Chatterji elected to the Anthony Wilkin Studentship; Dr. A. B. Appleton and Dr. H. W. K. Vines awarded the Raymond Horton-Smith Prize, 828; R. G. W. Norrish awarded the Gordon Wigan Prize; Proposed University Lectureship in Embryology, 828; Local Lectures, Report for 1921-22, 860; Dr. A. P. Maudslayi elected an Honorary Fellow of Trinity Hall, 893
- Canadian Rocky Mountains, Geological Explorations in the, Dr. C. D. Walcott, 18
- Cancer: and the Public, 766; New Growths and, Prof. S. B. Wolbach, 766; of the Breast and its Treatment, Prof. W. S. Handley. Second edition, 376; Research Fund, The Imperial, 266
- Canned: Foods, Dr. W. G. Savage, 366; Meat and Fish, Bacteriology of, Dr. W. G. Savage, R. F. Hanwicke, and R. B. Calder, 614
- Capillarity: W. Taylor, 377; R. M. Deeley, 543
- Carbon: -black in the United States; E. G. Sievers, 397; Dioxide, Velocity of Absorption of, by Ammoniacal Solutions, P. Riou, 591; Monoxide displaces Oxygen, Determinations of the Velocity with which, from its Combination with the Blood Pigment Haemoglobin, Dr. H. Hartridge and F. J. W. Roughton, 758; The Velocity with which, displaces Oxygen from its Combination with Haemoglobin, 2 parts, Dr. H. Hartridge and F. J. W. Roughton, 685; The Quantitative Determination of, and of Hydrogen by the Use of Chromic and Sulphuric Acids, L. J. Simon and A. J. A. Guillaumin, 623
- Carbonisation, Low Temperature, Prof. J. W. Cobb, 718
- Carnegie: Hero Fund, Award from the, to Dr. J. Spence, 524; Institution, The Magnetic Work of the, Dr. L. A. Bauer and others; Dr. C. Chre, 94
- Cass, Sir John, Technical Institute, Courses at the, 621
- Cassava, Bitter (*Manihot utilisima*), Growth and Transport of Organic Substances in, T. G. Mason, 831
- Cast Irons, The Thermal Modifications of Some, J. Durand, 623
- Castor, The System of, W. Rabe, 189
- Catalysis by Platinum Black, G. Vavon and A. Husson, 299
- Catalytic Actions at Solid Surfaces, A Study of, Parts viii. and ix., Dr. E. F. Armstrong and T. P. Hilditch, 62
- Cathode and X-rays, Emission of, by Celestial Bodies, Dr. H. Deslandres, 847
- CeIl, The, and the Surrounding Medium, Mechanism of the Exchanges between the, L. Lapique, 28

- Cells, Living, New Apparatus and Methods for the Dissection and Injection of, R. Chambers, 722
- Centaureidine, a Product obtained from Centaureine, M. Bridel and G. Charoux, 895
- Centaureine, a New Glucoside, extracted from the Roots of *Centaurea jacea*, M. Bridel and C. Charaux, 759
- Cepheid Variables, The Distance of the, Prof. H. Shapley, 645
- Cepheids, Parallaxes of 22; Dr. S. A. Mitchell, 493
- Ceramic Products, The Baking of, in Electrically Heated Furnaces, A. Granger, 235
- Ceremonial Exchange, Dr. A. C. Haddon, 472
- Ceylon: Birds and Some Invertebrates of, W. E. Wait; Dr. Annandale, 228; The Snakes of, 538
- Chaussées modernes, Les, Prof. P. Le Gavrian, 272
- Chelsea Porcelain, W. King, 871
- Chemical: Analysis, Qualitative, A Systematic: A Theoretical and Practical Study of Analytical Reactions of the more Common Ions of Inorganic Substances, Prof. G. W. Sears, 477; Apparatus, Catalogue of, A. Gallenkamp and Co., Ltd., 712; Combination and Sir Alfred Ewing's Magnetic Atom, Prof. A. P. Laurie, 100; Change and Catalysis, Prof. H. E. Armstrong, 367; Engineering Design, The General Principles of, H. Griffiths, 726; Examination of Water, Sewage, Foods, and other Substances, The, J. E. Purvis and T. R. Hodgson, 571; Foundation, The United States, 334; Industry, English, Germany and, 337; Society of, Glasgow Meeting of the, 130; The Society of, Activities of, 642; Lecture Diagrams, Modern, with Uses and Applications fully described, Dr. G. Martin, assisted by J. M. Dickson and Maj. J. W. Christelow, 571; Notes: General, T. Steel, 759; Plant Construction—Non-Metals, Materials of, H. Griffiths, 726; Society, Nominations of Officers of the, 524; Substances, The Weighing and Measuring of, H. L. Malan and A. I. Robinson, 726; Technology, 726; and Analysis of Oils, Fats, and Waxes, Dr. J. Lewkowsitch, Sixth edition, revised by G. H. Warburton. Vols. 1. and ii., 109; Works, New editions of, 305
- Chemicals, Fine, British and American, 653
- Chemie, anorganischen, Lehrbuch der, Prof. K. A. Hofmann. Vierte Auflage, 695
- Chemische Analyse, Die, Herausgegeben von Dr. B. M. Margosches. VIII.-IX. Band: Methoden zur Untersuchung von Milch und Molkeerprodukten, Dr. K. Teichert, 110
- Chemist, a Master, A Monument to, Dr. E. F. Armstrong, 142
- Chemistry: A Concise History of, Dr. T. P. Hilditch. Second edition, 305; A Modern Text-book of, Prof. H. B. Baker, 374; A New Treatise on, 801; and Life, 173; and Medicine, Prof. G. Barger, 69; Applied, A Dictionary of, Sir Edward Thorpe. Vol 3. Revised and enlarged edition, 305; Reports of the Progress of. Vol. 6, 1921, 147; Arabic, E. J. Holmyard, 573; Colloid, Prof. W. C. McC. Lewis, 892; Inorganic, Prof. T. M. Lowry, 374; and Theoretical, A Comprehensive Treatise on, Dr. J. W. Mellor. Vols. i. and ii., 802; Laboratory Exercises in, Prof. J. F. Norris and Prof. K. L. Mark, 602; International, 196; Micro Methods in the Practical Teaching of, Prof. E. C. Grey, 309; of the Plant Cell, 403; of the Sugars, Principal Irvine, 352; Organic, A Text-book of, Dr. A. Berntsen. New edition, revised to date, by Prof. J. J. Sudborough, 602; A Text-book of, Prof. J. S. Chamberlain, 805; Physical, An Introduction to the Principles of, from the Standpoint of Modern Atomistics and Thermodynamics, Prof. E. W. Washburn. Second edition, 305; Pure and Applied, International Union of, Sir William Pope elected President of the, 126, 197; International Union of, Annual Meeting of the, 190; Teaching of, Micro-chemical Methods in the Practical, J. W. Blagden and A. Wechsler, 447; The Tutorial. Part 2: Metals and Physical Chemistry, Dr. G. H. Bailey. Edited by Dr. W. Briggs. 12th impression (4th edition), 663
- Chemists at Utrecht, International Reunion of, 431
- Chetoptera, Comparative Spectroscopic Study of the Green Pigment of the, and the Chlorophyll of the Green Alga, *Ulva lactuca*, M. Romieu and F. Obaton, 200
- Chicago University, Bequest to, by S. Coman, 166
- Child Sacrifice at Carthage, Pouissote and Lautier, 322
- Childhood, Seven Ages of, Ella L. Cabot, 872
- Children and Museums, 301
- Chilian Earthquake, The, 683, 709
- Chimie, La, et la Vie, G. Bohn and Dr. Anna Drzewina, 173
- Chinese Tibet: Expedition to, Prof. J. W. Gregory and J. C. Gregory, 719; The Alps of, and their Geographical Relations, Prof. J. W. Gregory and J. C. Gregory, 826
- Chitral and the Pamirs, Devonian Fossils from, F. R. Cowper Reed, 291
- Chlorine, Isotopes of, Separation of, Dr. Ishino, 647
- Chlorophyll, Animal, J. F. Fulton, Jr., 429
- Chromic Oxidation of the Homologues of Acetic Acid, The, L. J. Simon, 268
- Chromium, Green Sulphate of, Some New Properties of the, A. Recoura, 28
- Chrysalids, Metallic Coloration of, A. Mallock, 344
- Cinema, The, and Agricultural Education, 642
- City and Guilds of London Institute, Report for 1921, 330
- Civil: Engineers, Institute of, Awards of the, 675; List Pensions, Grant of, 259
- Clarencetown-Paterson District, Geology and Petrography of the, Part ii., G. D. Osborne, 864
- Cleveland Technical Institute, The Bulletin of the, 321
- Climates and Photography, H. G. Cornthwaite, 429
- Climates of the Continents, The, W. G. Kendrew, 630
- Climatology, Brazilian, 291
- Clinical Laboratory Methods, A Manual of, Prof. C. L. Cummer, 731
- Coal: in South Africa, W. J. Wybergh, 786; -mining, An Elementary Text-book of, R. Peel. Revised and enlarged by Prof. D. Burns. Twentieth edition, 628; Swamps, The Physiography of the, Prof. P. F. Kendall, 811; -tar Colours in the Decorative Industries, A. Clarke, 768
- Cobalt and Nickel in Plants, The Presence of, G. Bertrand and M. Mokrgatnatz, 532
- Cochlea, The Mechanism of the, Dr. G. Wilkinson, 559, 737; Sir W. M. Bayliss, 632; Dr. W. Perrett, 633
- Codeine, The Estimation of, H. E. Annett and R. R. Sanghi, 722
- Coke in Domestic Appliances, The Efficiency of Low Temperature, Dr. Margaret W. Fishenden, 434
- Cold, Generation and Utilisation of, E. A. Griffiths and others, 618
- Coleoptera, New Social, Dr. A. D. Imms, 95
- Colombola of Spitsbergen and Bear Island, The, Prof. G. H. Carpenter and Miss K. C. J. Phillips, 100
- Colloidal Suspensions, Law of the Distribution of Particles in, with special reference to Perrin's Investigations, Prof. A. W. Porter and J. J. Hodges, 135
- Colloids, Corrosion and, Dr. G. D. Bengough and J. M. Stuart, 651
- Collophane, A. F. Rogers, 292
- Colombia, Discovery of the Ruins of an Ancient City in, Dr. J. A. Mason, 459
- Colorado University Catalogue, 1921-22, The, 435
- Colour: and Chemical Constitution, Part xvii., J. Moir, 64; Part xviii., J. Moir, 832; Symbolism, D. A. Mackenzie, 261; Vision and Syntony, Prof. E. H. Barton, 357; Dr. F. W. Edridge-Green, 513; H. S. Ryland, 668; Vision, Investigation of the, of 527 Students by the Rayleigh Test, Dr. R. A. Houstoun, 794
- Colours, The Quantitative Determination of, Prof. W. Ostwald, 751
- Columbia University, Bequest to, by A. F. Eno, 26
- Columbine, A Mutation of the, Prof. T. D. A. Cockerell and Dorothy Young, 701
- Columns: A Treatise on the Strength and Design of Compression Members, Dr. E. H. Salmon, 210
- Coma, A Physical Study of, L. C. Martin, 591
- Combustible Liquids, International Congress on, 818
- Comet: A New, Dr. Baade, 584; Notes, 712
- Comets, 785; Periodical, Miss J. M. Young, 89; M. Kamensky and others, 290; Mlle. V. Hansen; M. Kasakov, 613; Perrine's, and 1922a, 555

- Commons, House of, Representatives of the Universities in the, 720
- Congo, Insectivora from the, 365
- Consciousness, The Evolution of, A. W. Tilby, 147, 279; The Reviewer, 280
- Constantinople, The Walls and other Antiquities of, G. B. Gordon, 89
- Constellations' Names, Abbreviations of, 364
- Continents, The Flotation of, E. Gagnebin, 262
- Co-operation and the Problem of Unemployment, Capt. J. W. Petavel, 298
- Copepods, Parasitic, C. B. Wilson, 54
- Copper: and Bronze Ages of South America, The Baron E. Nordenskiöld, 141; Films, Structure and Chemical Activity of, and the Colour Changes accompanying their Oxidation, C. N. Hinshelwood, 62
- Coprosma Baueri*, End., J. Shirley and C. A. Lambert, 168
- Coral: -bearing Limestones of the Cainozoic within the Pacific, E. C. Andrews, 168; Black, Prof. S. J. Hickson, 217; Dr. M. Nierenstein, 313; Dr. F. A. Bather, 344; in Medicine, Prof. F. Jeffrey Bell, 481; Reefs of the Louisiade Archipelago, Prof. W. M. Davis, 56
- Corals, Deep-sea, in Western European Seas, The Geographical Distribution of Some, L. Joubin, 831
- CORRESPONDENCE.
- Absorbed Films, Density of, R. M. Deeley, 313
- Acoustic Research, Prof. F. Lyman, 773
- Acoustics of Enclosed Spaces, The, Sir Arthur Schuster, 247, 341
- After-image, the Positive, The movement of, Dr. F. W. Edridge-Green, 772
- American Slipper Limpet (*Crepidula fornicata*) and its Allies, Occurrence of a Crystalline Style in the, Dr. J. H. Orton, 149
- A New Worship? Prof. H. E. Armstrong, 700
- Animal Mechanism, H. S. Rowell, 542
- Annelids of Iceland and the Faroes, Rev. H. Friend, 342
- Anticyclones, The Cause of, W. H. Dines, 845
- Antimony, The Isotopes of, Dr. F. W. Aston, 732
- a-Particles as Detonators, Dr. H. H. Poole, 148
- Archannelids, Saccocirrus, and Protodrilus, on the South and West Coasts of England, On the Occurrence of the, Dr. J. H. Orton, 574
- Area, The Dimensions of, Dr. N. R. Campbell, 9
- Atmospheric: Electric Phenomena, One Possible Cause for—A Query, Sir Oliver Lodge, 512; A Reply, Dr. G. C. Simpson, 604; Turbulence, Telescopic Observation of, Catharine O. Stevens, 280
- Atomic: Model with Stationary Electrons, An, Dr. H. S. Allen, 310; Models of Bohr and of Lewis and Langmuir, A Possible Reconciliation of the, W. Hughes, 37
- Atoms: and Electrons, R. N. Pease, 379; and Elements, Periodic Structure of, H. N. Allen, 415; Bohr and Langmuir, Sir Oliver Lodge, 341
- Aurelia aurita*, The Mode of Feeding of the Jelly-fish, on the Smaller Organisms in the Plankton, Dr. J. H. Orton, 178
- Ball, Lightning, Prof. J. B. Cleland, 40
- Biography, Practical, First Lessons in, E. W. Shann, 736
- Births of Eminent People, Seasonal Incidence of the, Dr. F. J. Allen, 40
- Blood Relationships, Human, and Sterility, Christopher Blyare; The Writer of the Article, 846
- Bloomsbury, Dr. A. Morley Davies, 250; T. L. Humberstone, 250
- Botany, School Instruction in, Dr. Lilian J. Clarke, 512
- British Association: The, Prof. H. E. Armstrong, 341; The Local Handbook of the, B. Hobson, 605
- Broadcast "Rainbow," A, Prof. R. C. McLean, 605
- Browne, Sir Thomas, The Skull of, Sir Arthurl Keith and Prof. Karl Pearson, 149
- Cambridge: Advanced Mathematical Study and Research at, Prof. H. S. Carslaw, 8; and the Royal Commission, Sir William Kidgeway, 873; The Writer of the Article, 874
- Capillarity, W. Taylor, 377; R. M. Deeley, 543
- Chemistry: Arabic, E. J. Holmyard, 573; Micro Methods in the Practical Teaching of, Prof. E. C. Grey, 309; J. W. Blagden and A. Wechsler, 447
- Chrysalids, Metallic Coloration of, A. Mallock, 344
- Cochlea, The Mechanism of the, Sir W. M. Bayliss, 632; Dr. W. Ferrett, 633; Dr. G. Wilkinson, 737
- Colour Vision and Syntony, Dr. F. W. Edridge-Green, 513; H. S. Ryland, 668
- Consciousness, The Evolution of, A. W. Tilby, 279
- Coral: Black, Dr. M. Nierenstein, 313; Dr. F. A. Bather, 344; in Medicine, Prof. F. Jeffrey Bell, 481
- Cosmical Theory and Radioactivity, Prof. J. Joly, 112
- Cutting Tools, Action of, A. Mallock, 277, 603; H. S. Rowell, 413, 771; Prof. E. C. Coker, 700; Prof. A. Pollard; Prof. E. N. da C. Andrade, 875
- Dampier's "Discourse of the Winds" and the Distribution of Wind on the Earth's Surface, A. Mallock, 478
- Earth: Geology and the Primitive State of the, Dr. H. Jeffreys, 148; The Primitive Crust of the, Prof. G. A. J. Cole, 249; J. Parkinson, 413
- Earthquake Foci, The Variable Depth of, Dr. Dorothy Wrinch and Dr. H. Jeffreys, 310
- Echinoderm Larvæ and their bearing on Classification, Prof. Th. Mortensen, 806
- Echinus esculentus*, Habits of, R. Elmhirst, 667
- "Einstein's Paradox," Rev. H. C. Browne, 668; Prof. H. Wildon Carr, 669
- Electric Atoms, Ideal, A Type of, J. L., 873; Discharge in Oxygen, Peculiarities of the, Rev. Dr. P. J. Kirkby, 249
- Electrical: Analogue of the Vocal Organs, An, J. O. Stewart, 311; Condenser, A New Type of, Dr. T. F. Wall, 810
- Electrolytes in the Blood, Condition of, Prof. B. S. Neuhausen, 8
- Electron, Speculation concerning the Positive, Sir Oliver Lodge, 696
- Experimental Towing-Tank, An, used by Benjamin Franklin, P. C. Whitney, 10
- Eyes, Divided Composite, A. Mallock, 770
- Flat Soil falling through Water, The Track of a, E. W. Wetherell, 845
- Gas Pressures and the Second Law of Thermodynamics, R. d'E. Atkinson, 112; A. Fairbourn, 113
- Geology and the Nebular Theory, Prof. J. Joly; W. B. Wright, 76
- German Book Prices, Prof. K. C. Browning, 845
- Gravity Observations in India, R. D. Oldham, 665; Variations, Sir G. P. Lenox-Conyngham, 874; C. S. Wright, 875
- Green Ray at Sunset and Sunrise, The, Prof. A. W. Porter, 513; Capt. C. J. P. Cave, 604; Prof. W. M. Flinders Petrie, 604
- Harpoons under Peat at Holderness, Yorks, O. G. S. Crawford, 481; T. Sheppard, 701, 735
- Hearing, The Resonance Theory of, Dr. H. Hartridge, 9
- Helium: The Spectrum of, in the Extreme Ultra-Violet, Prof. T. Lyman, 278; The Spectrum of Neutral, Prof. C. V. Raman, 700; Neutral, Spectrum Lines of, Prof. W. M. Hicks, 309; Some Spectrum Lines of, derived Theoretically, Dr. L. Silberstein, 247, 248
- Hermit-crab (*Eupagurus bernhardus*), The Relationship between the Common, and the Anemone (*Sagarita parasitica*), Dr. J. H. Orton, 735, 877
- Histological Stains, Prof. A. E. Boycott, 114
- Hudson, W. H., Memorial, R. B. Cunningham Graham, 846
- Hydrogen Molecules: Bohr's Model of the, and their Magnetic Susceptibility, Prof. K. Honda, 664; The Secondary Spectrum of, A. C. Menzies, 876
- Intervals, The Measurement of, Prof. A. S. Eddington, 697; E. Cunningham, 698
- Irish Yew Trees, Sex of, Dr. C. J. Bond, 810
- Iron, The Mass Spectrum of, Dr. F. W. Aston, 312
- Isotopes, Series Spectra of, The Difference between, Prof. J. W. Nicholson, 37
- Lead and Animal Life, Miss K. Carpenter, 543
- Lepidopterous Larvæ, The effect of a Lead Salt on, Dr. F. C. Garrett and Hilda Garrett, 380
- Light, Rotary Polarisation of, Prof. F. Cheshire, 807; Dr. A. E. H. Tutton, 809
- Liquids, Transparency of, and Colour of the Sea, Prof. C. V. Raman, 280
- Lockyer, Sir Norman, Biography of, Lady Lockyer, 481

- Logarithmic Spiral, The Elliptic, C. E. Wright, 40; H. S. Russell, 214
- Luminous Phenomenon, A Curious, S. R., 481
- Magnetism, the Kinetic and Molecular Theories of, An Experimental Confirmation of, Dr. J. R. Ashworth, 10
- Masaris, Origin of the Name of the Genus, E. W. Adair, 574; F. A. B., 574
- Medical Education, Sir G. Archdall Reid, 769; Prof. W. J. Dakin, 845; J. S. Dunkerly, 846; J. T. Cunningham, 846
- Melbourne University Bill, The, Sir J. H. MacFarland, 39
- Mersenne's Numbers, Prof. G. H. Hardy, 542
- Mesoplodon Layardi*, from the Tasmanian Coast, Occurrence of the Rare Whale, Prof. T. T. Flynn, 379
- Metals, the Hardness of, A Curious Feature in, H. O'Neill and Dr. F. C. Thompson, 773
- Metre, The Legal Equivalent of the, Sir R. T. Glazebrook, 446
- Miraculous Draught of Fishes, The, Prof. E. W. Gudger, 572; T. R. R. S., 665; Sir Herbert Maxwell, 666; W. B. Drummond, 666; H. Harries, 666
- Molecular, Elliptropy in, Prof. C. V. Raman, 11; Viscosity, F. M. Lidstone, 733
- Molecules in a Magnetic Field, Orientation of, M. Holmes, 635
- Mollusca, Sex Change in, Prof. J. Brontë Gatenby, 544
- Moon, Colour Observations of the, A. F. Warth, 605
- NATURE Volumes, An offer of, M. Gheury de Bray, 737
- Nerve-Energy, On the Reality of, Prof. D. Fraser Harris, 312, 666; Dr. E. D. Adrian, 447
- Noctiluca as an Enemy of the Oyster, R. W. Dodgson, 343
- Nomenclature, A Question of, F. H. Masters, 543
- Oaks, Defoliation of, E. W. Swanton, 250; Sir Herbert Maxwell, 344
- Occult Phenomena and After-images, Prof. E. N. da C. Andrade, 843
- Opalescence Phenomena in Liquid Mixtures, Prof. C. V. Raman, 77
- Optical: Definition and Resolving Power, J. Evershed, 179; Dispersion, A Quantum Theory of, Prof. C. G. Darwin, 841
- Orumoeba, F. R. Rowley; R. Kirkpatrick, 40; G. Lapege, 114
- Oyster (*O. edulis*), and Crepidula, The Phenomena and Conditions of Sex-change in the, Dr. J. H. Orton, 212; The Conditions of Sex-change in the, Dr. R. Spärc, 480
- Patent, An Empire, E. W. Hulme, 633; E. E. Towler, 772
- Periodicities, Dr. G. T. Walker, 511; Sir W. H. Beveridge, 511
- Perseid Meteors in July 1592, H. Beveridge, 667
- Physics, The Dictionary of Applied, Sir R. T. Glazebrook, 699
- Pigeon Tick, The, L. H. Matthews and A. D. Hobson, 313; A. G. Lowndes, 380
- Plants, Mosaic Disease in, K. M. Smith, 668
- Polar and Non-polar Valency in Organic Compounds, W. E. Garner, 543
- Polarisation of Diffused Light under the Sea, E. E. Brooks, 114
- Potassium: Cyanide, The X-ray Structure of, P. A. Cooper, 544; Vapour in the Associated Series, Absorption of, Prof. A. L. Narayana and D. Gunnaiya, 250
- Radiolaria from Oozes, Extraction of, H. L. Thomas, 216; A. Earland, 216
- Rat and its Repression, The, Earl of Denbigh, 278
- Rate of Radioactive Disintegration by use of Penetrating Radiation, An Attempt to Influence the, Dr. G. Hevesy, 216
- Red Lithium Line, The Structure of the, Prof. T. R. Merton, 632
- Relativity: and Physical Reality, Dr. A. A. Robb, 572; and the Æther, Sir Oliver Lodge, 446; Paradox, A. C. C.; Prof. A. S. Eddington, 844
- Research and Razors, Prof. J. R. Partington, 415
- Rickets, The Cause of, Sir W. M. Bayliss, 212
- Rise of Temperature of Living Plant Tissue when infected by Parasitic Fungus, Dr. I. B. Pole Evans and Mary Pole Evans, 480
- Roche's Limits for Satellites, Prof. J. Joly, 179
- Rocks of the Earth's Crust, The Oldest Known, Prof. G. A. J. Cole, 39
- Rudbeckia and Aquilegia, Prof. T. D. A. Cockerell, 278
- Russian Names, Transcription of, Major-Gen. Lord Edward Gleichen, 78, 635; C. A. Hoare, 279; J. G. F. Druce and A. Glazunov, 512; J. H. Reynolds, 635
- Sand-flies, Pairing and Parthenogenesis in, A. D. Peacock, 215
- Science: and the Empire, Major A. G. Church, 876; The Influence of, Sir G. Greenhill, 78; Rev. A. L. Cortie, 180, 378; Sir Oliver Lodge, 277
- Scientific and Industrial Pioneers, Eng.-Capt. E. C. Smith, 846
- Scorpions and their Venom, Major C. E. F. Mouat Biggs, 250
- Scottish People, The Stature of the, Sir Arthur Keith, 8
- Selenium and some other Elements, The Isotopes of, Dr. F. W. Aston, 664
- Smell in Birds, Sense of, C. B. Williams, 149; Prof. A. Meek, 279
- Smoke of Cities, The, Prof. A. E. Boycott, 413; Prof. J. B. Cohen, 414
- Soil-acidity, Experiments on the Theory of, Prof. J. N. Mukherjee, 732
- Solenoids, Skin Effect in, G. Breit, 668
- Sound: The Production of a Standard Source of, Capt. E. T. Paris, 378; of Explosions, Transmission of, Sir Napier Shaw, 415
- Space-time Geodesics, Prof. H. T. H. Piaggio, 699; Dr. A. A. Robb, 809
- Spectra: New, of Water Vapour, Air, and Hydrogen in the extreme Ultra-violet, J. J. Hopfield, 732; Some Significant Relations in the Quantum Theory of, S. Ray, 215; the Principle of Selection in, An exception to, S. Datta, 39
- Spectrum of the Night Sky, Lord Rayleigh, 769
- Sterility, Interspecific, Dr. W. Bateson, 76; Prof. R. R. Gates, 179, 447; Prof. J. P. Lott, 843; Dr. J. W. H. Harrison, 312
- Surface Tension and Cell Division, H. G. Cannon, 181
- Tables of the Incomplete Gamma-Function, Prof. Karl Pearson, 669
- Time-Triangle and Time-Triad in Special Relativity, The, R. A. P. Rogers, 698
- Tropical Medicine, Discoveries in, Sir Ronald Ross, 38; Lt.-Col. A. Alcock, 114
- Values, A Coincidence in, L. M. Stewart, 279
- Vegetable Rennet, R. Hedger Wallace, 543
- Volcanic Shower in the N. Atlantic, Prof. G. A. J. Cole, 635
- Wasp, An Ancient, Prof. T. D. A. Cockerell, 313
- Water Snails and Liver Flukes, Dr. Monica Taylor, 701; R. Hedger Wallace, 845
- Waterspouts, Dr. G. D. Hale Carpenter, 414; Dr. D. Brunt, 414; W. J. Fisher, 669
- Wegener's Displacement Theory, P. Lake, 77; E. R. Roe-Thompson, 214
- Weights and Measures for India, New, H. Richards, 734; C. A. Silberrad, 735
- Winkle, The Freshwater, A. E. Hodge, 380
- Winter Thunderstorms, Capt. C. J. P. Cave, 877
- X-ray Reflection from Powdered Crystals, The Intensity of, Prof. W. L. Bragg and R. W. James, 148; Prof. A. H. Compton and N. L. Freeman, 38
- Zinc, the Isotopes of, Separation of, A. C. Egerton, 773
- Corrosion: and Colloids, Dr. G. D. Bengough and J. M. Stuart, 651; Control of, by Deactivation of Water, F. N. Speller, 84; of Ferrous Metals, The, 878; A. Pickworth, 83
- Cosmical Theory and Radioactivity, Prof. J. Joly, 112
- Cotton; Research in Egypt, 748; Spinning, W. Scott Taggart. Vol. ii. Sixth edition, 75
- Coué, Emile, The Man and his Work, H. MacNaughten, 376
- Creek Indians, The, I. R. Swanton, 646
- Cretaceous; and Tertiary Outliers of the West of England, The Petrography of the, Prof. P. G. H. Boswell, 62; Marine Transgression in the African Region, The, Dr. L. F. Spath, 291
- Crime and Remedial Punishment, 692
- Croesus, Coins of, Dr. L. Shear, 54
- Croystal: Analysis, X-ray, Ten Years of, Dr. A. E. H. Tutton, 47; Structure of Beryllium and Beryllium

- Oxide, L. W. McKeehan, 563; -symmetry, The Statement of, E. T. Wherry, 586
- Crystalline Style, Occurrence of a, in the American Slipper Limpet (*Crepidula fornicata*) and its Allies, Dr. J. H. Orton, 149
- Crystallised Sulphates from the Province of Huelva, Spain, H. F. Collins, 100
- Crystallographic Notation, Prof. H. Hilton, 100
- Crystallography: A Standard Treatise on, 303; and Practical Crystal Measurement, Dr. A. E. H. Tutton. Second edition. In 2 vols., 303; Graphical and Tabular Methods in, as the Foundation of a New System of Practice: with a Multiple Tangent Table and a 5-figure Table of Natural Cotangents, T. V. Barker, 629; Graphical Methods in, 629
- Crystals, Organic, The Structure of, Sir William Bragg, 115
- Cuckoos, Two, reared together in the same nest, Miss E. R. Saunders, 160
- Current Meters for Use in River Gauging, Dr. M. A. Hogan, 292
- Curtis's Botanical Magazine* re-started, 674
- Cutting Tools, The Action of, Prof. E. G. Coker, 118, 706; A. Mallock, 277, 603; H. S. Rowell, 413, 771; Prof. A. Pollard, 875; Prof. E. N. da C. Andrade, 876
- Cyanosis, the Production of, The Quantitative Influences of Certain Factors involved in, C. Lundsgaard and D. D. Van Slyke, 504
- Cyclohexanol, The Preparation of, A. Brochet, 623
- Cyclones, New Theory of, Dr. E. Kuhlbrodt, 91
- Cylindrical Journal Lubrication at High Values of the Eccentricity, The Characteristics of, Dr. T. E. Stanton, 794
- Cystoscopic Irradiator, A, and an Ultra-violet Light Illuminator, J. S. van der Lingen, 236
- Czechoslovak Republic, The, J. Cisaf and F. Pokorný, 839
- Dairy Cattle, The Feeding of, Prof. A. C. McCandlish, 695
- Dakota Series, The Flora of the, C. W. Berry, 291
- Daly, Charles P., Medal presented to Sir Francis Young-husband, 158
- Dampier's "Discourse of the Winds" and the Distribution of Wind on the Earth's Surface, A. Mallock, 478
- Dams: The Design and Construction of, including Masonry, Earth, Rock-fill, Timber, and Steel Structures, also the Principal Types of Movable Dams, E. Wegmann. Seventh edition, 661
- Dante and Averrhoism in Italy, Prof. Castiglioni, 296
- Dartmoor Granite, The: Its Accessory Minerals and Petrology, A. Brammall and H. F. Harwood, 99
- Darwinia Homoranthus*, Species of, and Rylstonea in N.S.W., Victoria, South Australia, and Queensland, E. Cheel, 236
- Darwinism, The Present Position of, Sir Arthur Keith, 393; Dr. J. C. Willis and others, 751
- Datura Stramonium*, A large Specimen of, H. E. Stone, 525
- DEATHS.
- Balfour (Prof. I. Bayley), 781, 816
- Battermann (Prof. H.), 258
- Bell (Dr. Alexander Graham), 225
- Bergmann (Prof. E.), 425
- Bone (Mrs. W. A.), 225
- Bouty (Prof. E.), 883
- Brown (Prof. A. Crum), 610, 673
- Brown (Prof. F. D.), 490
- Bryant (F. B.), 882
- Bryant (Dr. Sophie), 361, 458
- Codrington (Dr. R. H.), 425
- Degen (E.), 883
- Elevens (H. J.), 780
- Favé (L.), 361
- Fox (Howard), 851
- Godlewski (Prof. T.), 361
- Gowland (Prof. W.), 16
- Grove-Hills (Col. E. H.), 522, 551
- Gurney (J. H.), 781
- Hallwachs (Prof. W.), 158
- Harries (Dr. A. J.), 187
- Hastings (Dr. J.), 610
- Holt (E. W. L.), 17
- Horstmann (Prof. A.), 851
- Hudson (W. H.), 310
- Kapp (Prof. Gisbert), 257
- Kapteyn (Prof. J. C.), 48
- Kellner (Dr. W.), 491, 522
- Knott (Dr. C. G.), 610
- Kuenen (Prof. J. P.), 491, 673
- Langton (Dr. H.), 742
- Lemoine (Prof. G.), 850
- Mayer (Prof. A.), 491
- Mayor (Dr. A. G.), 224
- McClure (Canon E.), 781
- McRobert (Sir Alexander), 17
- Miller (H. W.), 851
- Möller (Prof. A.), 781
- Monaco (Albert, Prince of), 17, 156
- Moore (Sir Norman), 781, 817
- Nobbe (Prof. F.), 610
- Noelting (Prof. E.), 425
- Onslow (Hon. V. A. H. H.), 85
- Parkin (Sir George R.), 49
- Pollock (Prof. J. A.), 359
- Powell (H. J.), 742
- Ransome (Dr. A.), 225, 256
- Rubens (Prof. H.), 740, 741
- Salomonson (Prof. J. K. A. W.), 552
- Sharp (Dr. D.), 361, 521
- Smith (Prof. Alexander), 457
- Smith (Prof. C. Michie), 491, 610
- Smith (S. P.), 187
- Solvay (Ernest), 84
- Sturley (Dr. A. A.), 674
- Sudeley (Lord), 851
- Takamine (Dr. J.), 361
- Tawney (C. H.), 225
- Trouton (Prof. F. T.), 459, 490
- Tschugaefi (Prof. L.), 781
- Tupman (Lt.-Col. G. L.), 742
- Visger (Mrs. J. A. Owen), 257
- Waller (Mrs. A. D.), 708
- Walter (L. H.), 459
- Ward (John), 49
- Waterhouse (Major-Gen. J.), 491, 552
- Wesley (W. H.), 583, 609
- Willis (Dr. A. R.), 86
- Willis (Dr. R. W.), 851
- Wislicenus (Prof. W.), 50, 223
- Delambre, J. B. J., Centenary of the Death of, 259
- Desensitising of Silver Bromide-gelatin Plates, The, Dr. T. Slater Price, 849
- Deutsche Gesellschaft für Vererbungswissenschaft, Second Annual Meeting of the, 583
- Development Commission, The, 865
- Devonian Fossils from Chitral and the Pamirs, F. R. Cowper Reed, 291
- Dextrose in Water, Solubility of, 227
- Diabetes:  $\beta$ -oxybutyric Acid and Levulose, A. Desgraz, H. Bierry, and F. Rathery, 623; Insipidus, Experimental, Bailey and Bremer, 748; The Use of a Pancreatic Extract in, Sir C. S. Sherrington, 774
- Dialectic, Prof. H. Wildon Carr, 208
- Dialkylvinyl-carbinols, The Preparation of the, R. Locquin and S. Wouseng, 63
- Diamond, The Matrix of, A. M. MacGregor; H. S. Harger, 262
- Dianthus, The South African Species of, J. Burt-Davy, 27
- Dicrostichus magnificus*, Rainbow, H. A. Longman, 495
- Diet and Race: Anthropological Essays, F. P. Armitage, 308
- Dietetics, Modern, 336
- Differential Invariants and other Concomitants of Quadratic Differential Forms in Four Variables, Prof. A. R. Forsyth, 27
- Diffusion and Intertraction, C. G. Schoneboom, 62
- Diphenols, The Ultra-violet Absorption Spectra of the, F. W. Klingstedt, 430

- Diptera Danica: Genera and Species of Flies hitherto found in Denmark. W. Lundbeck. Part vi. Pipunculidæ and Phoridae, 602; Researches on, Dr. A. E. Cameron; Major W. S. Patton; F. W. Edwards, 396
- Dirigible Balloons, Experiments on the Guidance of, through Fog by the Method of W. A. Loth, E. Fournier, 863
- Discours et mélanges, Prof. E. Picard, 629
- Dominance Ratio, The, R. A. Fisher, 100
- Donders, F. C., Reden gehalten bei der Enthüllung seines Denkmals in Utrecht, am 22 Juni 1921, Prof. C. A. Pekelharing and others, 147
- "Donneurs de sang," The, in Veterinary Medicine, L. Panisset and J. Verge, 136
- Drahtlöser Übersee-Verkehr, Dr. G. Eichhorn, 374
- Drainage of Agricultural Land, Proposed Scheme for the, 426
- Draper Gold Medal of the National Academy of Sciences of the U.S.A. presented to Prof. H. N. Russell, 820
- Drone-Fly, Attack on a, by a Wasp, Major E. E. Austen, 323
- Drought of 1921, The, C. E. P. Brooks and J. Glasspoole, 55
- Drugs in Commerce: Their Source, Preparation for the Market, and Description, J. Humphrey, 7
- Durée et Simultanéité: Apropos de la théorie d'Einstein, H. Bergson, 503
- Durham: University Calendar, 530; Philosophical Society, Election of Officers of the, 784
- Dust-raising Winds, Dr. C. W. B. Normand, 262
- Dutch Zoological Society, The Fiftieth Anniversary of, Prof. J. F. van Bemmel, 589
- Dye Industry, The French, 164
- Earth: Currents in France, Dr. A. Nodon, 888; Evolution and its Facial Expression, Prof. W. H. Hobbs, 270; The Primitive Crust of the, Prof. G. A. J. Cole, 249; J. Parkinson, 413
- Earthquake: Foci, The Variable Depth of, Dr. Dorothy Winch and Dr. H. Jeffreys, 310; in the Midland Counties, 393; of August 7, 1895, in Northern Italy, R. D. Oldham, 757; Waves, The Propagation of, Dr. J. H. Jeans, 704
- Earthquakes: Focal Depths of, Prof. H. H. Turner, 55; in the Region around Tokyo, Prof. Omori, 162
- Earth's Crust: Chemical Composition of the, Prof. W. Vernadsky, 229; The, and its Composition, T. Crook, 253; The Oldest-known Rocks of the, Prof. G. A. J. Cole, 39
- Earth's Structure, The, and its Evolution, 270
- Earthworks in America, C. C. Willoughby, 585
- East: Africa, Twenty-five Years in, Rev. John Roscoe, 36; Anglian Institute of Agriculture, H. M. McCreath elected Principal of the, 530
- Eastman Kodak Company, Research Laboratory of the, Abridged Scientific Publications from the, Vol. 4, 644
- Eaux souterraines, Nouveau Traité des, E.-A. Martel, 242
- Echinoderm Larvæ and their Bearing on Classification, Prof. H. Mortensen, 806
- Echinus: *esculentus*, Habits of, R. Elmhirst, 667; *miliaris*, the lantern of Aristotle in, The Development of the Calcareous Parts of, D. W. Devanese, 26
- Echtfärbung der Zellkerne, Untersuchungen über, mit künstlichen Beizenfarbstoffen und die Theorie des histologischen Färbeprozesses mit gelösten Lacken, Prof. S. Becher, 33
- Ecological Investigation, The Methods of, Dr. E. J. Salisbury, 208
- Edaphon: Das, Untersuchungen zur Ökologie der bodenbewohnenden Mikroorganismen, Dr. R. H. Francé. Zweite Auflage, 206
- Edinburgh: and East of Scotland College of Agriculture, Calendar of the, 621; Royal Society of, Election of Officers and Council of the, 612; University, J. A. S. Watson appointed Professor of Agriculture and Rural Economy; Conferment of Degrees, 133; Conferment of Honorary Degrees; Dr. E. M. Wedderburn appointed Professor of Conveyancing, 198; C. G. Darwin appointed Tait Professor of Natural Philosophy, 720
- Education: How to Measure in, Prof. W. A. McCall, 601; Psycho-analysis and, Dr. C. W. Kimmins and others, 650; Research and Invention, Prof. H. S. Heleshaw, 715; The Board of Technical Institutions and, 657
- Educational and School Science, Sir Richard Gregory, 420
- Eel: the Blood of, The Variation of the Osmotic Pressure of, as a Function of Modifications of the Salinity of the External Medium, P. Portier and M. Duval, 332; The Life History of the, Dr. Johs. Schmidt, 716; the "Wiped," Osmotic Pressure of the Blood of, on a Function of Modifications of the Salinity of the External Medium, P. Portier and M. Duval, 864
- Efficiency of Man, The, and the Factors which influence it, Prof. E. P. Cathcart, 354, 453
- Egg, the Germinal Localisations of the, The Properties of, A. Brachet, 622
- Ego: The Beloved, Foundations of the New Study of the Psyche, Dr. W. Stekel. Translated by R. Gabler, 805
- Egypt, Excavations in, Lord Carnarvon and H. Carter; Sir E. Wallis Budge, 783; Science in, Col. H. G. Lyons, 283
- Einstein: Bergson and, Prof. H. Wildon Carr, 503; Pour comprendre, l'Abbé Th. Moreux, 508
- Einstein'schen Relativitätstheorie: Die Grundlagen der, eine kritische Untersuchung, Prof. H. Strasser, 568
- Einstein's: Paradox, Rev. H. C. Browne, 668; Prof. H. Wildon Carr, 669; Theories, H. Reichenbach and others, 308
- "Electrets," the Analogues of Magnets, M. Sató, 714
- Electric: Atoms, A Type of Ideal, J. L., 873; Conduction in Metals, An Electron Theory of, E. H. Hall, 687; Discharge in Gases at Low Pressures, The Minimum Potential of, E. Dubois, 831; Power Systems, W. T. Taylor, 506; Power, The Control of, 373; Traction, Railway, F. W. Carter, 338
- Electrical: Analogue of the Vocal Organs, An, J. O. Stewart, 311; Condenser, A New Type of, Dr. T. F. Wall, 810; 885; Engineering Principles of, Prof. W. H. Timbie and Prof. V. Bush, 506; Engineers, Institution of, Dr. J. A. Fleming elected an Honorary Member of the, 745; Furnace, An, with Molybdenum Resistance *in vacuo*, P. Fleury, 795; Review, Jubilee of the, 709; Theory, Modern, Supplementary Chapters—Chapter xv.: Series Spectra, Dr. N. R. Campbell, 767
- Électricité atmosphérique, B. Chauveau. Premier Fasc.: Introduction historique, 406
- Électricité générale, Problèmes et exercices d', Prof. P. Janet, 147
- Electricity, S. G. Starling, 176; and Matter, Sir Ernest Rutherford, 182; Applied, 595; Pure and Applied, 474; Technical, 506; Technical, H. T. Davidge and R. W. Hutchinson. Fourth edition, 840
- Electrified Conducting Layers, The Resistance of Thin, H. A. Perkins, 436
- Electrochemical Effects produced by superimposing Alternating Currents upon Direct Currents, W. R. Cooper, 135
- Electrode Potential Drop, Measurements of, with Direct Current and Alternating Current Electrolysis, S. Marsh and A. E. Evans, 722
- Electrodynamics: An Introduction to, from the Standpoint of the Electron Theory, Prof. L. Page, 509
- Electrolytes in the Blood, Condition of, B. S. Neuhausen, 8
- Electrometer: A New, with Rigid Pointer designed for the Measurement of Radiations, B. Szilard, 136; An Absolute Plane-cylinder, L. Bouchet, 831
- Electron, Positive, Speculation concerning the, Sir Oliver Lodge, 606
- Electrons emitted from a Hot Tungsten Filament, The Kinetic Energy of, J. H. Jones, 722
- Electrotherapy and Diagnosis, An Essay on the History of, Dr. H. A. Colwell, 32
- Elektrizität und des Magnetismus. Einführung in die Theorie der, Zum Gebrauch bei Vorträgen, sowie zum Selbstunterricht, Prof. Max Planck, 474
- Elektrotechnik, Lehrbuch der, Dr. E. Blattner. Erster Teil. Vierte Auflage, 176
- Elettrotecnica elementare con numerosi problemi. A. Occhialina. Vol. 1, 474

- Elliot, D. G., Gold Medal of the National Academy of Sciences of the U.S.A. awarded to Prof. O. Abel, 188
- Elliott, John, Memorial Pathological and Bacteriological Laboratory, Opening of the, 460
- Elliptic Logarithmic Spiral, The, C. E. Wright, 40; H. S. Rowell, 214
- Emotions, The, C. G. Lange and W. James, 730
- Empire: Patent, An, E. W. Hulme, 633; E. E. Towler, 772; Science and the, 797; Water-power, Dr. Brysson Cunningham, 767
- Encephalitis Lethargica, Report on, A. C. Parsons, with Contributions by Dr. A. S. MacNalty and J. R. Perdrau, 626
- Encres, Les, les cirages, les colles et leur préparation, M. de Keghel, 731
- Engineering: Drawing, An Introduction to, J. Duncan, 476; Hydro-electric, Vol. 1, Civil and Mechanical, H. D. Cook and Dr. A. H. Gibson, 108; Inspection, Prof. E. A. Allcut and C. J. King, 730; Institutions, Movement for Closer Co-operation amongst, 227; Progress in, Dr. W. H. Maw, 857
- Engineers, Society of, Awards of the, 885
- Englands Handelskrieg und die chemische Industrie, Prof. A. Hesse and Prof. H. Grossmann. Band 1; Band 2, Neue Folge; Band 3, Herausgegeben von A. Hesse, H. Grossmann, und W. A. Roth, 337
- English: Channel, The Geological Study of the Bottom of the, L. Dangeard, 865; Place-names, A Survey of, Prof. A. Mawer, 133; Science Masters and the Teaching of, 127
- Engraving and Etching, Processes of, Prof. A. M. Hind, 583
- Entelodonts from the Oligocene of South Dakota, W. J. Sinclair, 21
- Entomology: Applied, An Introductory Text-book of Insects in their Relations to Man, Prof. H. T. Fernald, 35
- Eocene: Lizard, Redescription of an, C. W. Gilmore, 190; Mollusca and Foraminifera from Nigeria, R. B. Newton; E. Heron-Allen and A. Earland, 322; of Wyoming, Owl from the, A. Wetmore, 190
- Equal Pay: for Equal Work? Should Men and Women Receive, Prof. F. Y. Edgeworth, 533; to Men and Women for Equal Work, Prof. F. Y. Edgeworth, 391
- Equisetum arvense*, Somatic Kinesis in the Aerial Stem of, M. Lenoir, 64
- Erzlagertatten: Abriss der Lehre von den, In Anlehnung an die dritte Auflage des Lehrbuches und unter Benützung hinterlassener Aufzeichnungen, Prof. R. Beck, bearbeitet durch G. Berg, 205
- Eskimos, Copper, The Life of the, D. Jenness, 245
- Espace, La Motion d', Prof. D. Nys, 471
- Espace, Temps et Gravitation: la théorie de la relativité généralisée dans ses grandes lignes, Prof. A. S. Edington; Ouvrage traduit de l'anglais, J. Rössignol, 410
- Essex Rivers, Evolution of the, and of the Lower Thames, Prof. J. W. Gregory, 308
- Ether,  $\alpha$ - $\beta$ -dichlorethyl, V. Grignard and A. C. Purdy, 2091
- Ethylene, The Absorption of, by Sulphuric Acid, A. Daniens, 623
- Etna, Mount, and Upper Air Currents, Prof. F. Eredia, 291
- Eucalyptus Oils, The Miscibility Test for, C. E. Fawsitt and C. H. Fischer, 468; Relationship between Oil-glands and Oil Yields in the, M. B. Welch, 592
- Eugenics: and the Improvement of the Human Race, Dr. J. G. Adami, 853; International Commission of, First Annual Meeting of the, 642
- Europe, Political Change in, The Belt of, Prof. J. F. Unstead, 529; Recent Geographical Work in, W. L. G. Joerg, 530; The Peoples of, Prof. H. J. Fleure, 768; The Reopening of, Prof. G. A. J. Cole, 599; Warm Winters in, Spell of, C. E. P. Brooks, 557
- European Fish in New Zealand Waters, Hon. G. M. Thomson and the late T. Anderton, 266
- Eutectics, The Structure of, F. L. Brady, 531
- Euterpes matangensis*, The Rôle of the Soldiers in, J. Bathellier, 591
- Evaporation, Prof. J. W. Hinchley, 130; The Control of, by the Temperature of the Air, J. R. Sutton, 64
- Everest, Mount: District, Geology of the, Dr. A. M. Heron, 22; The Reconnaissance, 1921, Lieut.-Col. C. K. Howard Bury and others, 139; Expedition, 18, 87, 150; a Film Record of the, Capt. J. B. L. Noel, 743, 884
- Evolution, Movement against the Teaching of, in Minnesota, 883
- Evolutionary Naturalism, Prof. R. W. Sellars, 631
- Excavations in Sussex and Surrey, 782
- Exchange, Theory of the Phenomena of, J. Rueff, 863
- Excreta, Methods of Collection and Disposal of, suitable for Small Tropical Villages, Lt.-Col. Clemesha, 232
- Exhibition of 1851, Award of Senior Studentships, 98
- "Existence," The Treatment of, in Recent Philosophical Literature, Prof. R. F. A. Hoernlé, 830
- Explosions: Propagation of the Sound of, 619; Sound of, Transmission of, Sir Napier Shaw, 415
- Eyes: and Spectacles, Dr. M. Rohr, rendered into English by Dr. A. H. Levy, 376; Divided Composite, A. Mallock, 770
- Falkland Islands: Fossil Plants from the, Prof. A. C. Seward and J. Walton, 861; Geological Investigations in the, Dr. H. A. Baker, 861
- Faraday: Medal of the Institution of Electrical Engineers, Presentation of the, to O. Heavside, 460; Society, Election of Officers and Council of the, 784
- Farm: Book-keeping: the Principles and Practice of Book-keeping applied to Agriculture: for Agricultural Colleges, Extension Classes, Evening Classes, and Practical Farmers, J. Kirkwood, 768; Management: a Text-book for Student, Investigator, and Investor, Prof. R. L. Adams, 404
- Farming: English, Past and Present, Lord Ernle. Third edition, 204; Scientific Management of, 404
- Fat and Oil Chemistry, Progress in, 109
- Fats, The Unsaponifiable Matter of, D. W. Steuart, 894
- Fauna of the Sea-bottom, The, Dr. C. G. J. Petersen, 527
- Ferrous Metals, The Corrosion of, 878
- Field: Geologists, Handbook for, Dr. C. W. Hayes, Revised and Enlarged by S. Paige. Third edition, 412; Glasses, Telescopes *versus*, Dr. A. Sonnefeld, 292; Museum of Natural History, Chicago, Appointments at the, 158
- Films of Metal on Large Surfaces, Depositing, by Cathodic Projection, P. Lambert and A. Andant, 268
- Filtration: an Elementary Treatise on Industrial Methods and Equipment for the Filtration of Liquids and Gases for those concerned with Water Supply, Ventilation, and Public Health; Chemists, Mechanical Engineers, and others, T. R. Wollaston, 663
- Finger-prints: The Forging of, J. C. Goodwin, 190; The Study of, Identification of Cows, C. L. Enos, 646
- Fireball: A Large, on July 26, 189; on October 31, 678
- Fireballs, Large, W. F. Denning, 821
- Fire-damp and Coal Dust, Ignition of, Appointment of a Committee on the, 460
- Fireflies, Phosphorescent Light of, Dr. H. E. Ives, 679
- Fish, European, in New Zealand Waters, Hon. G. M. Thomson and T. Anderton, 266
- Fishery Research, W. B. Hardy, 865
- Fishes: Cartilaginous, Variation of the Osmotic Pressure of the Blood of the, P. Portier and M. Duval, 28; The Cranial Morphology of, E. P. Allis, jr.; Dr. H. L. Kesteven, 748; The Defensive Spines of, H. M. Evans, 26
- Fishing: and Fishing Lore, H. Balfour, 534; from the Earliest Times, W. Radcliffe, 534; Industry, The, Dr. W. E. Gibbs, 840
- Flagellates, E. Penard, 228
- Flamsteed's Letters to Richard Towneley, Dr. J. L. E. Dreyer, 525
- Flat Soil falling through Water, The Track of a, E. W. Wetherell, 845
- Flint Implements, Development of, A. Vayson, 128
- "Floating Islands," Ecology of, H. Nakano, 646
- Flora: Land, The Early History of the, Dr. D. H. Scott, 666; of the Cheyenne Sandstone of Kansas, The, C. W. Berry, 201
- Florentine School of Physics and Optics, A, Dr. L. C. Martin, 496



- Flowers: Ephemeral, Observations and Experiments on, A. D. de Virville and F. Obaton, 655; Insects, and Guinea-pigs, Experiments in crossing, Prof. Meisenheimer, 750
- Fluid Motion, Discontinuous, The Line of Action of the Resultant Pressure in, Dr. S. Brodetsky, 794
- Flying, High-altitude, Rapid, Prof. A. Rateau, 41
- Fonctions elliptiques, Introduction à l'étude des, à l'usage des étudiants des facultés des sciences, Prof. P. Humbert, 308
- Food, The Preservation of, by Freezing, with Special Reference to Fish and Meat, Prof. W. Stiles, 101
- Foraminifera of the Atlantic Ocean, J. A. Cushman, 365
- Forensic Medicine and Toxicology, Dr. J. D. Mann. Sixth edition, revised throughout by Dr. W. A. Brend, 571
- Forest: Management, A Short Manual of, H. Jackson, 407; Mensuration, Prof. H. H. Chapman, 407; Policy and Management, 407
- Forestry: Commissioners, Second Annual Report of the, Year ending Sept. 30, 1921, 369; Practice and Available Timber Supplies throughout the Empire, R. L. Robinson, 159; Schlich's Manual of, Vol. 1: Forest Policy in the British Empire, Sir William Schlich. Fourth edition, 407
- Form- and Acet-aldehydes, The Estimation of, E. W. Blair and T. S. Wheeler, 894
- Formal Lamp, A, E. Berger, 28
- Forstera or Forsteria, The Use of the Name, Dr. B. Daydon Jackson, 750
- Forward Progression, 728
- Fossil: Bryozoa (Polyzoa) in the Department of Geology, British Museum (Natural History), Catalogue of the. The Cretaceous Bryozoa (Polyzoa). Vol. 4: The Cribrimorphs, Part 2, Dr. W. D. Lang, 445; Fish from Southern Italy, Prof. G. D'Erasmus, 190; Remains in the United Kingdom, Gift for the Preservation of, Dr. W. R. Parker, 460
- Foulerton Professorship, Prof. E. H. Starling appointed to the, 787
- Franklin: Benjamin, An Experimental Towing-tank used by, P. C. Whitney, 10; Gold Medal of the Franklin Institute presented to Sir Joseph J. Thomson, 188
- Fraxinus excelsior*, Twin-leaves and other Abnormalities in the Common Ash, T. A. Sprague, 757
- Freezing Machine, A New, with Air as the Working Fluid, M. Leblanc, 136
- Freiburg University, Dr. H. Lecher appointed Professor of Organic Chemistry in, 466
- French Dye Industry, The, 164
- Frequented Ways: a General Survey of the Land Forms, Climates, and Vegetation of Western Europe, considered in their Relation to the Life of Man; including a Detailed Study of some Typical Regions, Dr. Marion I. Newbigin, 599
- Frog, The Rhythm of Discharge of the Spinal Centres in the, Prof. W. A. Jolly, 468
- Frog's Gastrocnemius reflexly excited, The Electrogram of the, Prof. W. A. Jolly, 236
- Fruit: Farming: Practical and Scientific, for Commercial Fruit Growers and others, C. H. Hooper. Second edition, 601; -growing and Research, 497
- Frye Reflecting Telescope, The, 364
- Fuel in Relation to Health, Prof. J. W. Cobb, 232
- Functions, Real, New Properties of all, H. Blumberg, 687
- Fungi, Physiology of, G. M. Armstrong; R. W. Webb, 128
- Furia infernalis*, Sir Arthur Shipley, 27
- Galactic System, The, Dr. Harlow Shapley, 545, 578
- Galen's Work on Anatomical Administration, Dr. D. Campbell, 296
- Gales, Heavy, in July, 87
- Gallinaceæ, Sex-linked Heredity in the, A. Pézard and F. Caridroit, 796
- Galton, Francis, 1822-1922: a Centenary Appreciation, Prof. Karl Pearson, 335
- Gamma-Function, Tables of the Incomplete, Prof. Karl Pearson, 669
- Gas: Analysis, Differential, A Method of, Dr. G. A. Shakespear, 615; Calorimeter, A Recording and Integrating, Dr. J. S. G. Thomas, 251; Gasoline, Natural, H. B. Milner, 791; in 1920, E. G. Sievers, 791; Pressures and the Second Law of Thermodynamics, R. d'E. Atkinson, 112; A. Fairbourn, 113; Supply, The Thermal Basis of, Prof. J. W. Cobb, 671; The Explosive Potential of a, G. Holst and F. Oosterhuis, 623
- Gasteropod, A New (fam. Euomphalidæ), from the Lower Marine Series of N.S.W., J. Mitchell, 300
- Gastropods, Giantism among, B. B. Woodward, 128
- Gelatin, Dr. T. Slater Price, 280
- Geobotanische Untersuchungsmethoden, Prof. E. Rübel, 208
- Géographie, La, de l'histoire: Géographie de la paix et de la guerre sur terre et sur mer, J. Brunhes et C. Valbaux, 175
- Geography: Human, Dr. Marion I. Newbigin, 353; First Principles and Some Applications, Dr. Marion I. Newbigin, 416; School, The Scope of, Dr. R. N. R. Brown, O. J. R. Howarth, and J. Macfarlane, 245
- Geological: Congress, The International, of 1922, 715; Mapping of the Globe, L. Koch and others, 91
- Geologists' Association Foulerton Award given to A. S. Kennard, 882
- Geology: A Text-book of, Prof. A. W. Grabau, 2 Parts, 143; American General and Economic, 143; The Nebular Theory, Prof. J. Joly; W. B. Wright, 76; and the Primitive State of the Earth, Dr. H. Jeffreys, 148; and Petrography of the Clarendon-Paterson District, Part 1, G. D. Osborne, 236; Economic, General, A Text-book, Prof. W. H. Emmons, 210; of Antarctic Lands, D. Ferguson and others, 96; of the British Empire, The, Dr. F. R. C. Reed, 5; of the North Sea Basin, Prof. P. F. Kendall and others, 890; Economic Aspects of, C. K. Leith, 143
- Géométrique, Étude, des Transformations birationnelles et des courbes planes, H. Malet, 276
- Geophysical and Geochemical Observatories, A Plea for, T. A. Jagger, 884
- German: Book Prices, Prof. K. C. Browning, 845; Chemicals and France, Profs. Béhal, Haller, and Moureu, 820; Dyes, France and, 226; Men of Science and Physicians, Society of, Centenary Celebrations, Prof. B. Rassow, 750; Science, The Development of, Prof. Max Planck, 750; Universities, Gifts to, by Industrial Concerns, 466; Universities, Number of Students in, 755
- Germany and English Chemical Industry, 337
- Glacial Waters of Argentière and Bossons, The, d'Arsonval, Bordas, and Touplain, 27
- Glaciation of the Counties of Antrim, etc., Dr. A. R. Dwerryhouse, 167
- Glands in Health and Disease, Dr. B. Harrow, 658
- Glانville, John, and Psychical Research in the Seventeenth Century, H. S. Redgrove and I. M. L. Redgrove, 36
- Glare from Motor Headlights, 557
- Glasgow: Royal Technical College, Calendar of the, 684; University, A. D. Lindsay appointed Professor of Moral Philosophy, 25; Bequest to, by Sir William Lorimer, 26; Gift from H. Mehan, 859, 893
- Glass: Colourless, Selenium in the Production of, A. Cousen, 830; Industry, The, and Methods of Manufacture in Czecho-Slovakia, Prof. W. E. S. Turner, 830; The British Scientific, Prof. W. E. S. Turner, 833; Optical, Durability of, T. Haigh; Dr. J. Weir French, 97; Painting, Medieval, Processes and Methods of, J. A. Knowles, 687; Research, Prof. W. E. S. Turner and others, 430; Sheet, Influence of Alumina in preventing the Devitrification of, during the Drawing Process, K. Kamita, 63; The Devitrification caused upon the Surface of, by Heat, Y. Amenomiya, 63; Stained and Painted, Modern Developments in the Making of, H. J. Powell, 687; Surfaces, Abraded, Structure of, F. W. Preston, 162; Technology, Society of, The Frank Wood Medal of the, presented to G. G. Middleton and H. W. Howes, 784; The Journal of the Society of, 19
- Glauconite from the Greensand near Lewes: The Constitution of Glauconite, A. F. Hallmond and E. G. Radley, 100

- Glaze Storm in America, A. J. Henry, J. E. Lockwood, and D. A. Seelye, 01
- Glider, British-built, Offer by Selfridge and Co. of a Prize for Flight by a, 643
- Gliding: Contests, Results of, 581; or Soaring Flight, in Germany, 288
- Globular Clusters in the Large Magellanic Cloud, 584
- Gloucester Cathedral, The Painted Glass of, G. M'N. Rushforth, 585
- Glycerine, The Distillation of, T. H. Gray, 130
- Gold: Coast, New Maps of the, 647; -leaf Electrometer, Rev. A. Bennet Inventor of the, 126
- Gorgas Memorial Institute of Tropical and Preventive Medicine, The, 492
- Grain: Pests (War) Committee, Reports of the, Royal Society. Nos. 1 to 10, 145; -size and Diffusion, J. H. Andrew and R. Higgins, 467
- Graphical Analysis: a Text-book on Graphic Statics, W. S. Wolfe, 412
- Graptolites, Evolution of the, Dr. Gertrude Elles, 262
- Grasses, South Indian, A Handbook of Some, Rai Bahadur K. Ranga Achariya, assisted by C. Tadulinga Mudaliyar, 376
- Gravitational Waves, The Propagation of, Prof. A. S. Eddington, 721
- Gravity: Observations in India, R. D. Oldham, 665; Variations, Sir G. P. Lenox-Conyngham, 874; C. S. Wright, 875
- Great: Britain, Agricultural Research in, 93; Lakes Region, A Naturalist in the, E. R. Downing, 444
- Greek Biology and Greek Medicine, Dr. C. Singer, 631
- Green Flash at Sunset, The, Sir Arthur Schuster, 370; at Sunset and Sunrise, Prof. A. W. Porter, 513; C. J. P. Cave; Prof. W. M. Flinders Petrie, 604
- "Green Ray," The: or "Green Flash" (Rayon Vert), at Rising and Setting of the Sun, Prof. M. E. Mulder, 370
- Greenland, The Bacterial Flora of, Dr. C. Barthel, 366
- Greenwich, The Royal Observatory, 356
- Gypsum, Transformation of, into Ammonium Sulphate, C. Matignon and M. Fréjaques, 200
- Gypsy: English, Christian Names, E. O. Winstedt, 90; Folklore, T. W. Thompson, 556
- Gyroscope, Some Applications of the, P. Schilowsky, 829
- Hampshire, T. Varley, 339
- Hanbury Medal of the Pharmaceutical Society, The, presented to Prof. E. Perrot, 554
- Hancock Museum, Newcastle-upon-Tyne, T. R. Goddard appointed Curator of the, 583
- Harmonism and Conscious Evolution, Sir Charles Walston (Waldstein), 443
- Harper-Adams Agricultural College, Prof. C. Crowther appointed Principal of the, 399
- Harpoons under Peat at Holderness, Yorks, O. G. S. Crawford, 481; T. Sheppard, 735
- Harrison Memorial, The, 717
- Harvard College Observatory, Report of the, 127
- Hawaiian: Grasses, A. S. Hitchcock, 614; Natural History, 365; Zonitidae and Succineida, Notes on, C. M. Cooke, jr., 365
- Head-hunting in Assam, L. H. Hutton, 322
- Heads of Departments in Pure and Applied Science, Association of, Annual General Meeting of the, 860
- Health: and Weight Probabilities, Prof. Karl Pearson, 228; Public, Relative Values in, Sir Arthur Newsholme, 820, 853
- Hearing, The Resonance Theory of, Dr. H. Hartridge, 9
- Heat: and Light in Chemical Combination with other Elements, C. A. C. Nicoresti, 524; in Water, The Propagation of, J. R. Sutton, 832
- Heating and Ventilation in Passenger Ships, J. L. Musgrave, 586
- Heavens, The New, Prof. G. E. Hale, 2
- Hedgehog, The, and Virus of Rabies, Mme. M. Phisalix, 796
- Hegel: The Ethical Theory of, A Study of the Philosophy of Right, Prof. H. A. Reyburn, 70
- Hegelian: Dialectic, Studies in the, Dr. J. McT. E. McTaggart. Second edition, 208; Method and Modern Science, The, 70
- Height Record, A New, J. A. McCready, 87
- Helicinidae, Radula of the, H. B. Baker, 396
- Helium: Neutral, Spectrum Lines of, Prof. W. M. Hicks, 309; The Spectrum of, Prof. C. V. Raman, 700; in the Extreme Ultra-violet, Prof. T. Lyman, 278
- Hemerocallis fulva*, Median Proliferation of Flowers of, Dr. J. C. Costerton, 494
- Heredity, Prof. Johannsen, 750; Acquired, J. Costantin, 167; Handbook of, On Review of his, Dr. M. J. Sirks, 394; in the Human Race, Dr. Lenz, 750
- Hermit-crab (*Eupagurus bernhardus*), The Relationship between the Common, and the Anemone (*Sagarita parasitica*), Dr. J. H. Orton, 735, 877
- Herring: Catch in Winter, The Prediction of the Value of the, E. Le Danofs, 864; Fishery, The, and its Fluctuations, B. Storrow, 705
- Herschel, William, Centenary of the Death of, 255
- Hersperopithecus, The Anthropoid Primate of Western Nebraska, Prof. H. F. Osborn, 281
- Hevea brasiliensis*, The Role of Calcium Chloride in the Coagulation of the Latex of, G. Vernet, 686
- Hexosamines and Mucins, Dr. P. A. Levene, 292
- Hiera Picra, C. J. S. Thompson, 296
- Highway Engineering, 272
- Histological Stains, Prof. A. E. Boycott, 114
- History: and Science Different Kinds of Knowledge? Are, R. G. Collingwood, Prof. A. E. Taylor, and Dr. F. C. S. Schiller, 231; of the World, A Short, H. G. Wells, 867; Unified Human, F. S. Marvin, 867
- Hockey in Ancient Greece, 556
- Hog Louse, Structure and Biology of the, Miss L. Florence, 396
- Holophane, Ltd., Visit to the New Showrooms and Laboratories of, by the Circle of Scientific, Technical, and Trade Journalists, 554
- Homework and Hobby Horses, edited by H. C. Cook, 211
- Homo (Os Modernos Estudos sobre a origem do homem), Prof. A. A. M. Corrêa, 510
- Homogeneous Balanced Action, The Mathematics of the, Prof. J. P. Dalton, 468
- Homoranthus virgatus*, and *H. flavescens*, The Essential Oils of, A. R. Penfold, 896
- Honey that drove Men Mad, Prof. W. R. Halliday and Prof. McLean Thompson, 462
- Hong-Kong: Meteorology at, T. F. Claxton, 229; Students of the University of, Sir Frederick Lugard, 894; University, the Aims and Needs of, 828
- Hookworm Infection in Brazil, 1918-20, Studies on, Dr. W. G. Smilie, 169
- Horniman Museum, The, A Handbook to the Collections illustrating a Survey of the Animal Kingdom, H. N. Milligan. Second edition, 412
- Horse: -chestnut, Seedlings of, Dr. A. B. Rendle, 26; Serum, Separation of the Globulins of, M. Vila, 687
- Hovering Flight in the Mediterranean, H. Fabre, 863
- Hudson, W. H., Memorial, R. B. Cunninghamham Graham, 846
- Hull: and the East Riding, 539; and the East Riding of Yorkshire, Handbook to, prepared for the Members of the British Association for the Advancement of Science on the Occasion of their Visit to Hull, in September 1922. Edited by T. Sheppard, 539; Gift of Site for Advanced Technical Departments, T. R. Ferens, 530; Municipal Museum, The, T. Sheppard, 291
- Humaine, L'Expérience, et la causalité physique, Prof. L. Brunschvicg, 471
- Human: Blood Relationships, 738; Dentition, The Origin and Evolution of the, Prof. W. K. Gregory, 834; Development, The Trend of, H. Jackson, 554; Skull and Bones in an Ancient Gold Working at Gwanda, Rhodesia, 612; Society, The Theory of, Studies in, Prof. F. H. Giddings, 571; Traits and their Social Significance, Dr. I. Edman, 146
- Humanism, The Philosophy of, and of other Subjects, Viscount Haldane, 471
- Humidity and Vesicular State, The Influence of, on the Diffusion in Air of Drops containing Micro-organisms, A. Trillat, 332
- Humpback Whale from the Miocene of California, R. Kellogg, 322
- Hybrid, Disjunction and Combination of the Characters of the Parents in a, P. Vuillemin, 436

- Hydraulics: Elementary, for Technical Students, Prof. F. C. Lea, 839; with Working Tables, E. S. Bellasis. Third edition, 34
- Hydrocarbons in Dying Leaves, The Disappearance of, R. Combes and Mlle. Denise Kohler, 623
- Hydrochloric Acid and Potassium Chloride in Presence of Sucrose, The Electrical Conductivity of, A. J. Kieran, 136
- Hydro-electric Engineering, vol. i., Civil and Mechanical, H. D. Cook and Dr. A. H. Gibson, 108
- Hydrogen: Concentration of Natural Waters, The, and Some Etching Reagents in Relation to Action of Metals, Dr. W. R. G. Atkins, 758; Ion Concentration of Sea Water near the Coast, Diurnal Variations of the, R. Legendre, 724; Lines Ha and H $\beta$ , Structure of the, A. E. M. Geddes, 862; Molecule, The, Prof. A. C. Crehore, 587; Positive Rays, The Scattering of, and the Existence of a Powerful Field of Force in the Hydrogen Molecule, G. P. Thomson, 654; Selenide, The Viscosity and Molecular Dimensions of, C. J. Smith, 758; The Secondary Spectrum of, A. C. Menzies, 876
- Hyperacoustics, J. L. Dunk. Division ii.: Successive Tonality, 411
- Idromeccanica Piana, Prof. U. Cisotti. Parte prima e parte seconda, 243
- Igneous Rocks: in relation to Petrogenic Theories, The Frequency-distribution of, W. A. Richardson, 756; rich in Alkalies, The Origin of, Dr. S. J. Shand, 323
- Illuminating Engineering: in relation to the Architect, L. M. Tye, 746; Progress in, 746
- Index Animalium, C. Davies Sherborn. Sectio Secunda 1801-1850. Part I., 3
- Indexing Scientific Literature, G. S. Fulcher, 679
- India: Central, Marine Fossils in, 556; Cretaceous Fossil Reptiles in, Dr. C. A. Matley, 90; Gravity Observations in, R. D. Oldham, 665; Industrial Research in, 59; Impending Abolition of the Posts of Electrical Adviser to the Government of, and Chief Engineer of the Hydro-Electric Survey of, 88; Selections from Educational Records. Vol. ii., 894; The Probable Amount of Monsoon Rainfall for 1922, Dr. G. T. Walker, 159; The Weights and Measures of, C. A. Silberrad, 325, 735; H. Richards, 734
- Indian: Barley, Germination of, W. Youngman, 585; *Industries and Labour, Journal of*, August, 553; Institute of Science, Bangalore, 649; Dr. M. O. Forster appointed Director of the, 258; Leeches, Some, T. Kaburaki, 822; Painting and Mohammedan Culture, Sir T. W. Arnold, 228; Science Congress, Forthcoming, 643
- Individual, The, and the Community, R. E. Roper, 340
- Industrial: Pioneers, Calendar of, 61, 99, 135, 166, 199, 234, 267, 298, 331, 368, 400, 436, 467, 499, 531, 562, 591, 622, 654, 685, 721, 756, 793, 829, 861; Research in India, 59
- Influenza: Essays by several authors. Edited by Dr. F. G. Crookshank, 30; The Bacteriology of, Dr. M. Gordon, 293
- Infusorien über Flimmerbewegung, Lokomotion und Reizbeantwortung, Studien an, Dr. F. Alverdes, 509
- Inks, C. Ainsworth Mitchell, 426
- Insect Pests: of Fruit Trees, Collected Leaflets on, 427; of the Horticulturalist: their Nature and Control, K. M. Smith and J. C. M. Gardner. Vol. i., Onion, Carrot, and Celery Flies, 694
- Insects: Coaptations of, The Development of some, L. Cuénot and R. Poisson, 591; The Psychic Life of, Prof. E. L. Bouvier. Translated by Dr. L. O. Howard, 402; The Ways of, 402
- Installations électriques industrielles: choix du matériel, R. Cabaud, 474
- Insulation Testing, 586
- "Insulin" and the Oxidation of Sugar, Dr. Banting, 713
- Intellectual Co-operation Commission of the League of Nations, First Session of the, 362
- Interferometer Telescope, A Fifty-foot, Dr. G. E. Hale, 482
- Interferometers, List of, Adam Hilger, Ltd., 229
- Interferometry, Displacement, applied to Acoustics and to Gravitation, Prof. C. Barus, 7
- Intermetallic Actions, Q. A. Mansuri, 531
- Internal: Combustion Engine, The, Prof. W. E. Dalby, 122; Secretion, Sir W. M. Bayliss, 658; L. I. Hogben and F. R. Winton, 686; and the Ductless Glands, Prof. Swale Vincent. Second edition, 658
- International: Co-operation in Intellectual Work, E. C. Richardson, 883; Geological Congress, The, of 1922, 715; Research Council, The, 230
- Intersexuality, Recent Work on, Dr. R. de la Vaulx, 54
- Intervals, The Measurement of, Prof. A. S. Eddington, 697; E. Cunningham, 698
- Intestinal Flora, a Treatise on the Transformation of the, with Special Reference to the Implantation of *Bacillus Acidophilus*, Prof. L. F. Rettger and H. A. Cheplin, 694
- Intramolecular Ionisation, Prof. T. M. Lowry, 757
- Inventions, The Protection of: an Empire Patent, 437
- Ionic Permeability, The Elective, of the Cellular Elements, W. Mestrezat, P. Girard, and V. Morax, 168
- Ionizing Potentials, A New Method for studying, H. D. Smyth, 654
- Ions: Electrons, and Ionising Radiations, Dr. J. A. Crowther. Third edition, 340; The Effect of the, on Physiological Surfaces, Prof. Hoerber, Prof. Spiro, 751
- Ireland, The Royal College of Science for, 814
- Iridescent Marls, The Composition of the, M. Thiébaud, 532
- Iris: Structure of the Cell in the, P. A. Dangeard, 167, 200; The Light of, Variability in, Miss Harwood, 584
- Irish Yew Trees, Sex of, Dr. C. J. Bond, 810
- Iron: and Steel: at Temperatures below 280° C., The Changes in, F. C. Thompson and E. Whitehead, 794; Institute. Carnegie Scholarship Memoirs. Vol. ii.: The Corrosion of Iron, Dr. J. Newton Friend. Edited by G. C. Lloyd, 731; The Metallurgy of, based mainly on the Work and Papers of Sir Robert A. Hadfield, 507; -founding, B. Whiteley, 537; Industry, Sussex, Early History of the, K. Jenkins, 893; On the Electro-deposition of, with an Appendix containing a Bibliography of the Subject, W. E. Hughes, 445; The Corrosion of, Dr. J. Newton Friend. Edited by G. C. Lloyd, 731; The Mass-spectrum of, Dr. F. W. Aston, 312
- Isochronal Vibrations, Non-maintained, Three Classes of, and Three Types of Timepieces, J. Andrade, 63
- Isothermal Frontier of Ancient Cities, The, Dr. Vaughan Cornish, 558
- Isotopes: of Lead, separating the, A Chemical Method of, T. Dillon, Rosalind Clarke, and V. M. Hinchy, 167; Series Spectra of, The Difference between, Prof. J. W. Nicholson, 37
- Ithone fusca*, Life-history of, Dr. R. J. Tillyard, 495
- Japan, The Foundations of: Notes made during Journeys of 6000 Miles in the Rural Districts as a Basis for a Sounder Knowledge of the Japanese People, J. W. R. Scott, 538
- Japanese: Botanical Serials, New, 801; Geology, Prof. I. Hayasaka, Prof. H. Yabe and S. Hanzawa, 749; *Journal of Geology and Geography, The*, No. 1, 227; Pliocene Fossils, Prof. M. Yokoyama, 646; Social and Economic Life, 538
- Jena University, Grants to, from the Society of Friends of, 98
- "Judith," Gift to Science from the Performance of, 553
- Jungle, The Edge of the, W. Beebe, 211
- Jura Chain, The Nature and Structure of the Substratum of the, E. Fournier, 592
- Jussieu, B. de, The Work of, Abbé L. Parcot, 320
- Juvenile Delinquency, H. H. Goddard, 477
- Kaolin, The Problem of the Decomposition of, by Organisms, W. J. Vernadsky, 532
- Katanga, The Blue Crystals of Disthene found at, C. Cesáro, 864
- Kelvin Lecture, The, Sir Ernest Rutherford, 182
- Kent Coalfield, Water in the, E. O. Forster Brown, 822

- Kew, The Royal Botanic Gardens, 423; Major T. F. Chipp appointed Assistant Director of the, 189
- Kitchen Ranges, 434
- Knossos, New Discoveries at, Sir Arthur Evans, 125
- Knowledge: The Evolution of, G. Shann, 471; The Humanising of, Dr. J. H. Robinson, 298
- Kodaikanal Observatory, the Establishment of the, W. Pogson and, 711
- Kohlenhydrate und Fermente II. (1908-1919), Untersuchungen über, E. Fischer. Herausgegeben von M. Bergmann, 142
- Kontinente und Ozeane, Die Entstehung der, Dr. A. Wegener. Dritte Auflage, 798
- Korea, Weather in, 714
- Koristka Microscopes and Accessories, Catalogue of the, 52
- Kristalle, Das feinhaubliche Wesen der Materie nach dem Vorbilde der, Prof. F. Rinne. 2 und 3 Auflage, 839
- Kukkersite, the Oilshale of Esthonia, E. H. C. Craig, 55
- Kunzea corfolia*, The Essential Oil of, F. R. Morrison, 896
- Kwakiutl Indians, The, Dr. C. F. Newcombe, 190
- Labour: British, Replacement and Conciliation, 1914-21; Part 1, on Replacement, Co-ordinated and Revised by Miss L. Grier and Miss A. Ashley; Part 2, on Conciliation, Edited by A. W. Kirkaldy, 145
- Lac, Turpentine, and Rosin, Reports on, 159
- Lacertidae, Monograph of the, Dr. G. A. Boulenger. Vol. II., 410
- Lactic Fermentation, Studies on, C. Richet and Mme. A. G. Le Ber, 863
- Lake: Chad Region, Desiccation in the, F. W. H. Migeod, 786; Dwellings of Switzerland, Recent Investigations of the, Prof. E. Pittard, 12
- Lamps with Three Electrodes, Anode, Cathode, and Intermediate Grid where the Current is carried by Ions, and their Applications, M. Leblanc, 268
- Lancaster Astronomical and Scientific Association, Annual Report of the, 676
- Land: Drainage, W. L. Powers and T. A. H. Teeter, 211; Flora, The Early History of the, Dr. D. H. Scott, 606, 638
- Landowners and the State, Lord Bledisloe, 501
- Langley's, S. P., Pioneer Work in Aviation, Prof. L. Bairstow, 637
- Latex, The Coagulation of, L. Lindet, 758
- Laughter, Problem of, J. A. T. Lloyd, 396
- Lead: and Animal Life, Miss K. Carpenter, 543; and Zinc, The Mining District of North Cardiganshire and West Montgomeryshire, Dr. O. T. Jones, 476; Isotopes of, Separation of, Drs. T. Dillon and R. Clarke, and V. M. Hinchy, 430
- Leaf Pictures, Exhibition of, by W. J. King, 709
- League of Nations: Committee on Intellectual Co-operation of the, 87; Resignation of Dr. G. E. Hale; Appointment of Dr. R. A. Millikan, 460; First Session of the Intellectual Co-operation Commission of the, 362; Report of the European Health Conference of the, 362
- Lecythidaceæ, Flower Structure in the, Prof. McLean Thompson, 614
- Leeds University: Dr. W. T. David appointed Professor of Civil and Mechanical Engineering; Dr. J. W. McLeod appointed Sir Edward Brotherton Professor of Bacteriology, 25; Report of the Department of Coal Gas and Fuel Industries (with Metallurgy) for 1920-21, 26; A Gas Research Fellowship awarded to S. Pexton, 98; Dr. W. MacAdam appointed Medical Tutor and Registrar, and H. W. Symons and P. J. Moir appointed Clinical Assistants in Surgery, 133; Conferment of Honorary Degrees, 399, 435, 561; L. Abercrombie elected Professor of English Language and Literature, 530; Appointments in, 621; Sanction by the Treasury of a Grant in Aid of the new Agricultural Building; Gift by the Turner Tanning Machinery Co. to the Leather Industries Department; A. H. Priestley appointed Lecturer in Bacteriology and G. Priestley Assistant Lecturer in Cloth Analysis, 720; Students in, Assistance to the Laboratory of the British Silk Research Association; the Department of Agriculture; Gift of the Clothworkers' Company; Tribute to Prof. Smithells; Title of Emeritus Professor conferred on Profs. Kendall and Goodman; Dr. W. H. Pearsall appointed Reader in Botany, 893
- "Lektrik" Lighting Connections, G. C. Lundberg and the late W. P. Maycock. Seventh edition, 176
- Leonardo da Vinci's Work on the Structure of the Heart, Prof. Wright, 296
- Leonid Meteor Shower, The, W. F. Denning, 712
- Lepidopterous Larvæ, The Effect of a Lead Salt on, Dr. F. C. Garrett and Hilda Garrett, 380
- Leptospermum: flavescens*, The Essential Oils of two Varieties of, A. R. Penfold, 759; *Liversidgei*, Some Essential Oils from, A. R. Penfold, 300
- Libocedrus and its Cone in the Irish Tertiary, T. Johnson and J. G. Gilmore, 167
- Library of Congress, MSS. added to the, in 1921, 522
- Liebig's Annalen*, Prof. Wieland appointed to the Editorial Board of, 554
- Life in the Sea, The Progression of, Dr. E. J. Allen, 353, 448
- Light: Deflection of, in a Gravitational Field, H. Dingle, 389; Molecular Diffraction of, Prof. C. V. Raman, 505; Molecular Scattering of, 505; Rotary Polarisation of, Prof. F. Cheshire, 807; Dr. A. E. H. Tutton, 809; scattered by Mercury Vapour near the Resonance Periodicity, Polarisation of the, Lord Rayleigh, 654
- Lighting in Factories and Workshops, Departmental Committee on, Third Report of the, 89
- Lightning, Ball, Prof. J. B. Cleland, 40
- Lignite of Washing Bay, Co. Tyrone, T. Johnson and J. G. Gilmore, 167
- Lilies, the Formation of Anthocyanine in the Scales of the Bulbs of, Influence of Light on, M. Mirande, 592
- Liquids in Pipes, The Flow of, N. Swinden, 726
- Liverpool University, impending Retirement of Prof. F. Carey, 754
- L'Océanographie, Prof. J. Thoulet, 541
- Lockyer, Sir Norman: Biography of, Lady Lockyer, 481; Portrait Medallion of the late, 87; Observatory, Report of the, for 1921-22, Dr. W. J. S. Lockyer, 53; Unveiling a Portrait Medallion of the Founder, Speeches by Sir Richard Gregory, Lt.-Col. F. K. McClean, and Sir Frank Dyson, 192
- Locomotive, Electric, The, Sir Vincent Raven, 41
- Locomotives, Feed-water Heaters for, Prof. E. Sauvage, 41
- London: County Council, Programme of Lectures and Classes for Teachers, 331; General Omnibus Co., Ltd., Visit to the Repair Works of the, 783; Mathematical Society, Election of Officers and Council of the, 711; Proceedings of the. Second series. Vol. 20, 570; The Site and Growth of, C. E. M. Bromhead, 494; University: H. J. Waring elected Vice-Chancellor, 25; J. H. Woodger appointed University Reader in Biology at Middlesex Hospital Medical School; Sir Charles W. C. Oman appointed Creighton Lecturer for 1922-23; The Lindley Studentship for 1922 awarded to Miss M. J. Wilson-Smith; The University Studentship in Physiology for 1922-23 awarded to Miss M. A. Murray, 25; Bloomsbury and the T. Ll. Humberstone, 150; Dr. J. C. Drummond appointed Professor of Biochemistry at University College; Prof. A. Stokes appointed Dunn Professor of Pathology at Guy's Hospital Medical School; Conferment of Doctorates, 165; Acceptance by H. G. Wells of the Labour Candidature for Representation to Parliament, 166; Dr. J. F. Unstead appointed Professor of Geography, 198; History, Present Resources and Future Possibilities, Sir Gregory Foster, 240; T. Ll. Humberstone, 435; H. G. Wells adopted as Labour Parliamentary Candidate, 530; Dr. G. Senter and C. W. Crook elected to the Senate, 562; Scheme for the School of Hygiene; Question as to the Site for the University; Thanks accorded for Grant and Donation; Conferment of Doctorates, 590; F. J. F. Barrington awarded the William Julius Mickle Fellowship; Conferment of Doctorates, 720; Acceptance of a Bequest of Sir William Meyer; Continuance of the Franks Studentship in Archaeology, 859; Grant to the *Annals of Applied Biology*; Conferment of a Doctorate on Rev. G. H. Dix, 860; College, T. A.

- Stephenson appointed Assistant in the Department of Zoology and Comparative Anatomy, 435
- Long Barrows in the Cotswolds and Welsh Marches, O. G. S. Crawford, 585
- Loranthaceæ of Australia, The, Part ii., W. F. Blakely, 300
- Lord Howe Island, Some Australian Moths from, A. J. Turner, 864
- Lough Neagh Clays, The Lignite of the, Prof. Johnson and Miss J. G. Gilmore, 586
- Loughborough Technical College, Calendar of, 562
- Louisiade Archipelago, Coral Reefs of the, Prof. W. M. Davis, 56
- Low Temperature Carbonisation, Prof. J. W. Cobb, 718
- Lowestoft Fisheries Laboratory, Work of, E. S. Russell, 757
- Luminous Phenomenon, A Curious, S. R., 481
- Madeira, Biological Studies in, Dr. M. Grabham, 45
- Madras : Government Museum, Work at the, Dr. Gravely, 710 ; University, Bequest to, by Sir William S. Meyer, 754
- Magistri Salernitani nondum cogniti, Dr. Capparoni, 296
- Magnetic : Atom, The New, and its Properties, Sir J. A. Ewing and others, 162 ; Measurements in the Paris Basin, L. Eblé, 592 ; Work of the Carnegie Institution, The, Dr. L. A. Bauer and others, Dr. C. Chree, 94
- Magnetisation, The Atomic Process in, Sir J. A. Ewing, 862
- Magnetism : and Electricity, J. Paley York, New edition, 630 ; the Kinetic and Molecular Theories of, An Experimental Confirmation of, Dr. J. R. Ashworth, 10 ; The Origin of, Prof. A. O. Rankine and others, 616
- Man : and the Ice Age, Prof. P. F. Kendall and others, 617 ; The Efficiency of, and the Factors which influence it, Prof. Cathcart, 354, 453 ; The Study of, H. Peake, 354, 516
- Manchester : Birds, 1822-1922, T. A. Coward, 563 ; College of Technology, Courses at the, 621 ; Museums and Art Galleries, Lectures for Elementary School Children in, S. Hey, 582 ; New X-ray Department at, 753 ; University : E. D. Telford appointed Professor of Systematic Surgery, 26 ; Roll of Service, 111 ; Prof. J. S. Dunn appointed Procter Professor of Pathology, 133 ; W. W. C. Topley appointed Professor of Bacteriology, 134 ; Conferment of Doctorates, 198 ; a Fund to commemorate the Work of Prof. H. B. Dixon, 621 ; Opening of the Lewis Departmental Library ; Appointments in, 653
- Manila Typhoon of May 23, 1922, The, Rev. J. Algué, 795
- Mannite in Alkaline Solution, The Action of Boric Acid on, R. Dubrisay, 723
- Manson, Sir Patrick, Institution of a Memorial Medal to, 492
- Maori Mode of Drilling, The, E. Best, 679
- Marine : Biological : Association, Journal of the, 746 ; Laboratory, Plymouth, Prof. W. D. Henderson appointed Ray Lankester Investigator at the, 98 ; Deposits above Sea-level, Formation of, Dr. P. Bartsch, 396
- Marquesas Islanders, The Art of the, H. U. Hall, 128
- Mars : E. C. Slipher, Prof. W. H. Pickering, 428 ; M. Maggini ; Dr. Fountain, 364 ; Observations of, at Sétif, Algeria, R. Jarry-Desloges and G. Fournier, 160
- Masaris, Origin of the Name of the Genus, E. W. Adair ; F. A. B., 574
- Massachusetts Institute of Technology, Dr. S. W. Stratton elected President of the, 641
- Maternity and Child Welfare, Sir George Newman, 232
- Mathematics, Practical, A. Dakin. Part I., 375
- Mathématiques spéciales, Cours complet de, Prof. J. Haag. Tome 2, Géométrie, 375
- Measures, Metric and British, 29
- Mechanical : Engineers, Institution of, The Paris and Liège Meetings of the, 41 ; Testing : a Treatise in two Volumes. R. G. Batson and J. H. Hyde. Vol. i. : Testing of Materials of Construction, 804
- Mechanics, Theoretical : an Introductory Treatise on the Principles of Dynamics, with Applications and Numerous Examples, Prof. A. E. H. Love. Third edition, 243
- Medical Education, 683 ; Sir G. Archdall Reid, 769 ; Prof. W. J. Dakin, 845 ; J. S. Dunkerly ; J. T. Cunningham, 846
- Médicaments organiques, Préparation des, Prof. E. Fourneau, 69
- Medicine : Chemistry and, Prof. G. Barger, 69 ; History of, Third International Congress of the, 296 ; The Psychology of, Dr. T. W. Mitchell, 412
- "Meg" Insulation Tester, The, Evershed and Vignoles, Ltd., 586
- Melaleuca : *acuminata*, Lævo-phellandrene in the Oil of, H. G. Smith, 759 ; *linariifolia* and *Melaleuca trichostachya*, E. Checl, 236
- Melalucæ, The, and their Essential Oils, Part vi., R. T. Baker and H. G. Smith, 468
- Melanesia, Depopulation of, Essays on the, edited by Dr. W. H. R. Rivers, 594
- Melbourne University Bill, The, Sir J. H. MacFarland, 39
- Mendel, The Centenary of the Birth of, 491
- Mendelian Ratios, Problems of, R. A. Fisher, 786
- Mensch, Der fossile : Grundzüge einer Paläanthropologie, Prof. E. Werth. Erster Teil, 508
- Mentally Deficient Children : their Treatment and Training, Dr. G. E. Shuttleworth and Dr. W. A. Potts. Fifth edition, 663
- Menthone, The Stereoisomeric Forms of, R. S. Hughesdon, H. G. Smith, and J. Read, 895
- Merchant Venturers' Technical College, Calendar of, 562
- Mercury : in Gases, Variation of the Surface Tension of, J. G. Popesco, 268 ; The Production of the Spectrum of, G. Déjardin, 831 ; The Surface Properties of, E. Perucca, 623 ; Vapour : Energy Losses accompanying Ionisation and Resonance in, J. A. Eldridge, 563 ; The Determination of the Specific Inductive Capacity of, M. Bèdeau, 268
- Mercury : visible as a Morning Star, 553
- Mersenne's Numbers, Prof. G. H. Hardy, 542
- Mesoplodon *Layardi*, Occurrence of the Rare Whale, on the Tasmanian Coast, Prof. T. T. Flynn, 379
- Mesopotamia, Geology of, Dr. E. H. Pascoe, 21
- Mesothorium-2, The Chemical Properties of, D. Yovanovitch, 332
- Messel : Medal, The, presented to Prof. H. E. Armstrong, 130 ; Memorial Lecture, The First, Prof. H. E. Armstrong, 367
- Metabolism, Basal, Prof. Cathcart, 294
- Metallic State, The, Prof. C. A. Kraus, 165
- Metallografiska Institutet, Stockholm, Opening of the, Gift for a Scholarship by Sir Robert Hadfield, 18
- Metallography : in the Workshop, 837 ; Prof. C. H. Desch. Third edition, 305
- Metallurgical : Chemist : The, Prof. C. H. Desch, 710 ; The Work and Position of the, Sir Robert Hadfield, 51 ; Research, 462
- Metallurgy : Commercial, 71 ; of Iron and Steel, The, Prof. C. H. Desch, 537 ; of the Common Metals : Gold, Silver, Iron (and Steel), Copper, Lead, and Zinc, L. S. Austin. Fifth edition, 71 ; Modern, 507
- Metals : and Alloys, Cast, New Forms of Apparatus for determining the Linear Shrinkage and for Bottom-pouring of, F. Johnson and W. G. Jones, 531 ; crystalline, The Systems in which, J. L. Haughton and G. Winifred Ford, 136 ; Ferrous, The Corrosion of, A. Pickworth, 83 ; F. N. Speller, 84 ; Hardness of, A Curious Feature in the, H. O'Neill and Dr. F. C. Thompson, 773 ; Institute of : Admission of Student Members of the, 784 ; Programme of the, for 1922-1923, 394 ; The Effect of Temperature on some of the Properties of, Prof. F. C. Lea, 41 ; The Fatigue Failure of, C. F. Jenkin, 794 ; White, A. H. Munday, C. C. Bissett, and J. Cartland, 467
- Meteor : Great, of December 6, 886 ; Large, of October 17, W. F. Denning, 645 ; Shower, Possible Recurrence of a, 747 ; Showers, October, 493
- Meteoric : Flowers, Persistent, The Opening and Closing of, A. D. de Virville and F. Obaton, 759 ; Iron, The, of Karee Kloof, etc., Dr. G. T. Prior, 757
- Meteorological : Literature, A Bibliography of, 885 ; Theory in Practice, 762
- Meteors : A Theory of, and the Density and Temperature of the Outer Atmosphere to which it leads, Prof. F. A.

- Lindemann and G. M. B. Dobson, 794; August, 364; Recent, W. F. Denning, 613; September, 395
- Meters, Current, for Use in River Gauging, Dr. M. A. Hogan, 202
- Metre, The Legal Equivalent of the, Sir R. T. Glazebrook, 446
- Metric: and British Measures, 29; System, Sir Richard Gregory, 744; Progress of the, 459; for Engineers, C. B. Clapham, 340
- Mexico, Upper Cretaceous of, New Radiolites and a New Crinoid from the, L. W. Stephenson; F. Springer, 261
- Microbial Physiology and the Accessory Growth Factor, P. Goy, 64
- Microbiology: edited by Prof. C. E. Marshall. Third edition, 694; General, Laboratory Manual in, Second edition, 694
- Microdriili (Oligochaeta), The Pharyngeal Glands of the, Dr. J. Stephenson, 100
- Microscope: The: a Simple Handbook, C. Beck, 147; The Earliest Drawings made by means of the, Dr. C. Singer, 829; in Paper-making, J. Strachan, 99; The Use of the, in the Brewing Industry, A. Chaston Chapman, 99
- Microscopes and Microtomes, Catalogue of, The Bausch and Lomb Optical Co., Ltd., 303
- Microscopy, Colour Filters in, Kodak, Ltd., 679
- Military Medicine, Aspects of, 729
- Milk: The Peril of, Prof. H. F. Armstrong, 648; Whole, The Marketing of, Dr. H. E. Erdman, 579; -yield, The Variation of, with the Cow's Age and the Length of the Lactation Period, Prof. J. Wilson, 830
- "Millions" Fish, Chromosomes of the, Dr. O. Winge, 748
- Mimicry among Birds, G. T. Harris, 161
- Mind: The Machinery of the, Violet M. Firth, 146; The Abuse of, a Study of Bergson's Attack on Intellectualism, K. Stephen, 541
- Mineral: Land Surveying, Dr. J. Underhill. Third edition, 541; Resources: of Burma, The, N. M. Penzer, 74; of Great Britain, Special Reports on the, Vol. 2: Barytes and Withelite, G. V. Wilson and others. Third edition, 211; of Yugoslavia, 33
- Mineralogy, A Text-book of: with an Extended Treatise on Crystallography and Physical Mineralogy, Prof. E. S. Dana. Third edition, revised and enlarged by Prof. W. E. Ford, 210
- Minerals of the Oudjda Region (Morocco), J. Barthoux, 332
- Mining: Engineers, Institution of, and Institution of Mining and Metallurgy, Dinner of the, 709; and Metallurgy, Institution of, Award of Medals to Sir Alfred Keogh and Sir George Beilby, 553
- Ministry of Munitions and Department of Scientific and Industrial Research. Technical Records of Explosives Supply, 1915-1918. Nos. 5, 6, and 7, 777
- Minnesota University, Bequest to, by A. D. Thomson, 166
- Miracles and the New Psychology: a Study in the Healing Miracles of the New Testament, E. R. Mickle, 630
- Miraculous Draught of Fishes, The: an Explanation, Prof. E. W. Gudger, 572; T. R. R. S., 665; Sir Herbert Maxwell; Dr. W. B. Drummond; H. Harries, 666
- Mites injurious to Domestic Animals (with an Appendix on the Acarine Disease of Hive Bees), D. Hirst, 410
- Molecular: Elotropy in Liquids, Prof. C. V. Raman, 11; Scattering of Light in Vapours and in Liquids and its Relation to the Opalescence observed in the Critical State, K. R. Ramanathan, 655; Viscosity, F. M. Lidstone, 733
- Molecules in a Magnetic Field, Orientation of, M. Holmes, 635
- Molluscs of the Colorado Desert, Dr. S. S. Berry, 887
- Mondes, Origine et formation des, l'Abbé Th. Moreux, 660
- Monotremata, Interpretation of the Pelvic Region and Thigh of, A. B. Appleton, 862
- Monsoons as Rain Makers, Prof. A. McAdie, 324
- Montreal University, Destructive Fire at, 720
- Moon, Colour Observations of the, A. F. Warth, 605
- Mordellistena, A New Species of, parasitic on Termites, G. F. Hill, 759
- Morphine, The Estimation of, J. R. Nicholls, 722
- Mosaic Disease in Plants, K. M. Smith, 668
- Mosquito: Control: J. Marshall, 261; Lt.-Col. H. J. Walton, 838; Eradication, W. E. Hardenburg, 838; Investigations, 526
- Mosquitos, The Destruction of, by Eels, R. Dubois, 468
- Moth, Attack on a, by a Wasp, Miss M. M. Buchanan, 323
- Motor: Cars, Design of, Col. D. J. Smith, 644; Control: Industrial, Direct Current, A. T. Dover, 805
- Motorless or Wind Flight, Dr. S. Brodetsky, 483
- Mucins, Hexosamines and, Dr. P. A. Levene, 292
- Munster, edited by G. Fletcher, 339
- Muscarine, Dr. H. King, 526
- Museums: A Suggested Royal Commission on, 761; Children and, 301; National and Provincial, 320; Association, Presidential Address to the, E. E. Lowe; T. Sheppard elected President for 1924, 163
- Music, Various Factors involved in the Appreciation of, Dr. C. S. Myers, 232
- Mustard Gas Poisoning, Prof. G. Lovatt Evans, 32; The Medical Aspects of, Prof. A. S. Martin and Dr. C. V. Weller, 32
- Mycology: Applied, Review of, 189; Some Present-day Aspects of, F. T. Brooks, 563
- Myriapoda, H. W. Brolemann; R. V. Chamberlin, 90
- National: Academy of Sciences, U.S.A., The New Building of the, Dr. C. D. Walcott, 120; Physical Laboratory, Annual Visitation of the, 92; Collected Researches of the, Vol. 16, 462; Report of the, 1921, 363; Portrait Gallery, Earl of Ilchester, Sir Martin Conway, and W. B. Hardy appointed to the Board of Trustees of the, 394
- Natural: History Museum Staff Association, 88, 642; Philosophy, A Theory of, R. J. Boscovich. Latin-English edition, 870
- Nature: The Relatedness of, Prof. A. N. Whitehead, 63; Volumes, An Offer of, M. Gheury de Bray, 737
- Naval Architects, Institution of, Scholarships of the, 711
- Nebraska Tooth, The, W. P. Frycraift, 707
- Nebula: Dark, Prof. H. N. Russell, 81; New, D. H. Menzel, 364
- Nematode Parasite of a Lizard, A New, Vera Irwin-Smith, 759
- Nematodes of the Genus Physaloptera. Part iii., Vera Irwin-Smith, 300
- Nendrum, Ancient Monastery of, Discovery of the Remains of the, 459
- Neolithic Script in India, Hem Chandra Das Gupta, 365
- Neon, The Rectilinear Diameter of, E. Mathias, Dr. C. A. Crommelin, and Prof. H. Kamerlingh Onnes, 831
- Nephelectrometer, The, a New Apparatus, I. N. Kugelmass, 400
- Nerve-energy, On the Reality of, Prof. D. Fraser Harris, 342, 666; Dr. E. D. Adrian, 447
- Nerves, Outwitting our: a Primer of Psychotherapy, Dr. Josephine A. Jackson and Helen M. Salisbury, 477
- New: Guinea, Exploration of, from the Air, Capt. F. Hurley, 393; South Wales, Royal Society of, C. A. Sussmlich elected President of the, 126; Typical Wheat Soil of, a Chemical and Bacteriological Study of a, J. K. Taylor, 300; York, Allied Chemical and Dye Corporation of, Offer by the, of an Annual Prize to Chemists, 492; Zealand, Upper Cretaceous Gastropods of, Dr. O. Wilckens, 556; Alps, The Conquest of the, S. Turner, 872
- Newcomen Society, The, for the Study of the History of Engineering and Technology. Transactions. Vol. i., 1920-21, 409
- Newton, An Albino-crested, K. Norris, 188
- Nickel: Active, The Preparation of, for Organic Catalysis, A. Brochet, 759; Alloys retaining their Rigidity over an extended Temperature Range, P. Chevenard, 592; and Cobalt in the Biosphere, W. J. Vernadsky, 439
- Nigeria, Volcanic Activity in, A. A. Reading, 97; H. S. Cameron, 497
- Nigerian Plants of Economic Value, J. H. Holland, 323
- Nitrogen: and Alkaline Solutions, The Reactions between the Gaseous Oxides of, A. Sanfourche, 591; Fixing, A New Bacillus capable of, G. Truffaut and N.

- Bezssonoff, 623; Industrial, The Principles and Methods of Nitrogen Fixation and the Industrial Applications of Nitrogen Products in the Manufacture of Explosives, Fertilizers, Dyes, etc., P. H. S. Kempton, 805; Industry, The, Prof. C. H. Desch, Dr. J. A. Harker, and others, 670
- Nobel Prizes, Award of the, for Physics and Chemistry, for 1921 and 1922, 674
- Noctiluca as an Enemy of the Oyster, R. W. Dodgson, 343
- Nolanaceae, The Morphological Origin of the Internal Lifer of the, M. Mirande, 436
- Nomenclature, A Question of, F. H. Masters, 543
- Non-opaque Minerals, The Microscopic Determination of the, E. S. Larsen, 261
- North: American Gulls and Terns, Life-histories of, Order Longipennes, A. C. Bent, 339; Atlantic, The Hydrology of the, E. Le Danois, 655; Australian Termites, Some, G. F. Hill, 236; -East Coast Institution of Engineers and Shipbuilders, Report of the, for 1921-22, 642; of Scotland College of Agriculture, Calendar of the, 621; Sea, Currents of the, New Charts of the, Dr. G. Böhnecke, 885; Basin, Geology of the, Prof. P. F. Kendall and others, 890
- Northampton Polytechnic, Courses at the, 621
- Norwich Castle Museum Committee, Report of the, for 1921, 524
- Notothorium Mitchellii*, Turbinoid Bones of, H. H. Scott and C. Lord, 228
- Nova: in Lyra, The Reported, Dr. A. C. D. Crommelin, 821; Scorpii 1922, 645
- Nozzle Flow, Supersaturated Condition as shown by, Prof. A. L. Mellanby and W. Kerr, 41
- Numbers, The Theory of, Prof. G. H. Hardy, 352, 381
- Nursing Procedure, Pope's Manual of, Amy E. Pope, 445
- Nutrition, National, The Problem of, 226
- Oaks, Defoliation of, E. W. Swanton, 250; Sir Herbert Maxwell, 344
- Oat Straw as a Cattle Food, S. H. Collins and B. Thomas, 887
- Observer, A Reflective, 836
- Occult Phenomena and After-images, Prof. E. N. da C. Andrade, 843
- Ocean, Measuring the Depth of the, by Sound Waves, Dr. Hayes, 159
- Océanographie physique, Manuel d', Prof. J. Rouch, 840
- Ochetoceras, Phylogeny of, Marjorie O'Connell, 322
- Ohm, International, The Standard Reproduction of the, P. Janet, 235
- Ohms, International, Comparisons of the Standard Reproductions of the, R. Jouast, 235
- Oil: -drilling in Galicia, A. Miller, 749; Encyclopedia, The, M. Mitzakis, 474; Palm in French West Africa, The, 164
- Oils, Lubricating and Allied, E. A. Evans, 75
- Oilshale, Carboniferous Material in, 55
- Oil Shales, Dr. H. B. Cronshaw, 307
- Old Stone Age, Everyday Life in the, M. and C. H. B. Quennell, 443
- Oligochaeta: in the Antarctic, Distribution of, Prof. W. B. Benham, 823; Some Scottish, with a Note on Encystment in a Common Freshwater Oligochaete, *Lumbriculus variegatus* (Müll.), Dr. J. Stephenson, 723
- One and the Many, The, G. Cator, 894
- One-Teacher Schools, Modern Equipment for, 755
- Opalescence: Critical, The Variations of, with the Filling of the Tubes and the Nature of the Liquids studied, A. Andant, 63; Phenomena in Liquid Mixtures, Prof. C. V. Raman, 77
- Ophidia Topambana, or the Snakes of Ceylon, Col. F. Wall, 538
- Opium, The Estimation of Narcotine and Papaverine in, H. E. Annett and M. N. Bose, 722
- Optical: Cosine Law, The, T. Smith, 895; Definition and Resolving Power, J. Evershed, 179; Dispersion, A Quantum Theory of, Prof. C. G. Darwin, 841; Series and Röntgen Series of Lines, Analogies of Structure between the, L. de Broglie and A. Dauvillier, 723; Society of America, Seventh Annual Meeting and Exhibition of the, 676; Sonometer, An, Adam Hilger, Ltd., 464
- Optics, Physics and, A Florentine School of, Dr. L. C. Martin, 496
- Optique, l'Institut d', Report of, 426
- Orchis latifolia*, Linn. (marsh orchis), from the Island of Öland, Sweden, A. J. Wilmott, 757
- Ordnance Survey, Col. E. M. Jack appointed Director-General of the, 158
- Ore: Deposits, Prof. H. Louis, 205; Concerning the Review of, Dr. G. Berg, 583
- Organic Compounds: Influence of the Structure of, on their Oxidation by Chromic and Sulphuric Acids, L. J. Simon, 863; Polar and Non-polar Valency in, W. E. Garner, 543
- Organisms in Rocks capable of Reviving after Sterilisation by Heat, The Possibility of the Existence of, F. Dienert and P. Etrillard, 591
- Organomagnesium Compounds in Synthetic Chemistry, C. J. West and H. Gilman, 833
- Orthoptera and Dermaptera, Researches on, 822
- Otago University Museum, Annual Report of the, 1921, Prof. W. B. Benham, 362
- Oundle School, Dr. K. Fisher appointed Headmaster of, 330
- Ouramöba, F. R. Rowley; R. Kirkpatrick, 40; G. Lapage, 114
- Oxford: and Cambridge Bill, Universities of, 201; University, Conferment of Honorary Degrees, 60; Gifts by Sir William Dunn's Trustees for a School of Pathology and the Future School of Pharmacology, 720; Offer by L. Evans of a Collection of early Scientific Instruments, 828; Press General Catalogue, Third edition, 886
- Oxidation by Mixtures of Sulphuric Acid and Chromates, L. J. Simon, 168
- Oxygen: Electric Discharge in, Peculiarities of the, Rev. Dr. P. J. Kirkby, 249; Supply, Athletics and, Prof. A. V. Hill, 588
- Oyster (*O. edulis*) and *Crepidula*, The Phenomena and Conditions of Sex-change in the, Dr. J. H. Orton, 212; Dr. R. Spärck, 480
- Ozone, Pure, The Preparation and Properties of, Prof. E. H. Riesenfeld, 615
- Pagrosomus auratus*, The Food Value of the Snapper, W. M. Doherty, 896
- Paguridae, British and Irish, C. M. Selbie and Dr. S. W. Kemp, 191
- Paint and Varnish Technologists, An Institute of, to be founded, 394
- Palaeobotany and Earth-history, Prof. A. C. Seward, 585
- Palaeozoic Brachiopoda from Eastern Asia, I. Hayasaka, 161
- Palestine, Archaeology in, 556
- Palms, Climbing, and the Sago Palms, 372
- Pan-American Geologist*, The, 19, 321
- Panus stypticus*, Luminosity in, Prof. A. H. R. Buller, 563
- Paracelsus: Sir T. E. Thorpe, 202; Theophrastus Bombastus von Hohenheim, called, his Personality and Influence as Physician, Chemist, and Reformer, Prof. J. M. Stillman, 202
- Parasite, A Remarkable, P. Justesen, 128
- Parasitic Diptera, The Loss of the Faculty of Flight in, L. Cuenot and L. Mercier, 532
- Paris: Academy of Sciences, Sir William H. Bragg elected a Corresponding Member of the, 820; Astrographic Catalogue, The, J. Baillaud, 160; Observatory: The, 127; Report of the, for 1921, 712; on the 200th Anniversary of its Construction, G. Bigourdan, 895; Société de Géographie of, A Gold Medal of the, presented to Prof. J. W. Gregory, 820; University, Conferment of Honorary Doctorates upon Prof. Bordet, Prof. M. Lugeon, and Prof. A. Michelson, 754
- Parker and Haswell's Zoology, 765
- Parliament, University Representation in, 625
- Parliamentary Candidates, University, Unopposed Return of, 653
- Parsis, Religious Ceremonial of the, I. M. Casanowicz, 161

- Pasteur Centenary, 611; Preparations for the Celebration of the, 394; Celebration in Paris, 883
- Patent, an Empire, The Protection of Inventions, 437
- Patents for Inventions, J. E. Walker and R. B. Foster, 663
- Peabody Museum of Natural History, Appointments at the, 675
- Peking to India, Journey to, General Sir George Pereira, 852
- Penal Discipline, Mary Gordon, 692
- Penicillium glaucum* and of *Mucor stolonifer*, Mechanism of the Parasitic Action of, P. Nobécourt, 168
- Pepsin and Hydrochloric Acid, The Absorption of, by Foods, J. Ehrfont, 758
- Periodicities, Dr. G. T. Walker; Sir W. H. Beveridge, 511
- Perseid Meteors in July 1592, H. Beveridge, 667
- Petrography, Sedimentary: an Introduction to, with Special Reference to Loose Detrital Deposits and their Correlation by Petrographic Methods, H. B. Milner, 804
- Pétrole, Les Gisements de, J. Chutard, 474
- Petroleum: and Allied Industries, The: Petroleum, Natural Gas, Natural Waxes, Asphalts and Allied Substances, and Shale Oils, J. Kewley, 866; Industry, The, 866; H. B. Milner, 474; in the Philippines, Dr. W. D. Smith, 21; Products, The Supply of, 401; Standardisation of, Dr. A. E. Dunstan, 677; The Economics of, J. E. Pogue, 474
- Petrology of the Metamorphosed Rocks of the Start Area (South Devon), C. E. Tilley, 167
- Pflanzenanatomie, Handbuch der, herausgegeben von Prof. K. Linsbauer. Allg. Teil: Cytologie (Die Organe der Zelle). Bd. 1., Zelle und Cytoplasma, H. Lundegårdh; Bd. 2., Allgemeine Pflanzenkaryologie, Prof. G. Tischler, 176
- Pflanzenzelle, Chemie der, Prof. V. Grafe, 403
- Pharmaceutical Education and Research, 233
- Pharmacognosy and the Pharmaceutical Curriculum, Prof. H. G. Greenish, 233
- Pharmacy: in Great Britain and Ireland, J. B. Gilmour, 296; Italian, Art in the, of the 15th Century, Prof. Castiglioni, 296
- Phasma, A New, belonging to the Genus *Extatosoma*, W. W. Froggatt, 759
- Pheasants: A Monograph of the, W. Beebe. In four Volumes. Vol. iii., 105; Natural History of, 105
- Phellandrenes, The Chemistry of the, E. Hurst, H. G. Smith, and J. Read, 805
- Phellinus cryptarum*, The Destruction of the Woodwork at the Château de Versailles by, L. Mangin and N. Patouillard, 467
- Phenological Observations, 1921, J. E. Clark, H. B. Adames, and I. D. Margary, 27
- Philippine: Cattle Round-worm, B. Schwartz, 823; Foraminifera, J. A. Cushman, 261; Islands, Social Economics in the, R. F. Barton, 90
- Philosopher, A, with Nature, B. Kidd, 836
- Philosophical Congress at Manchester, The, 231
- Philosophy and the New Physics: an Essay on the Relativity Theory and the Theory of Quanta, Prof. L. Rougier. Translated by Prof. M. Masius, 568
- Phonation and Telephonic Audition, M. Marage, 687
- Phosphatic Fertilisers, 306
- Phosphorescent Sulphides, The Refractive Indices of the, M. Curie, 655
- Phosphorite, The Composition of, A. F. Rogers, 292
- Photo-elastic Researches on Engineering Problems, Recent, Prof. E. G. Coker, 41
- Photo-electric Phenomena and the Surface Tension of Mercury, The Relation between, J. G. Popesco, 299
- Photographic: Development, The Course of, A. P. H. Trivelli, F. L. Righter, and S. E. Sheppard, 397; Emulsions, Grain Size in, E. P. Wightman, A. P. H. Trivelli, and S. E. Sheppard, 714; Layer, The Deformability of the, C. Benedicks, 723; Lens from the Historical Point of View, The, Dr. R. S. Clay, 675, 739; Lenses, Cooke and Tassar, Unit Surfaces of, Miss Alice Everett, 829; Sensitometry and Testing, R. Davis and F. M. Walters, Jr., 430
- Photography: of Bullets in Flight, P. P. Quayle, 514; Optics, and Cinematography, Forthcoming International Exhibition of, in Turin, 583; *Record of*, No. 1, 363
- Photosynthesis: Dr. F. F. Blackman and others, 856; of Nitrogen Compounds, Profs. E. C. C. Baly, I. M. Heilbron, and D. P. Hudson, 129
- Phyllosiphon, A New Host of, G. Nicolas, 200
- Physaloptera, the Genus, Nematodes of, Part IV., Vera Irwin-Smith, 864
- Physical: Measurement, Physiological Aspects of, Sir J. Herbert Parsons, 824; Reality, The New Way of Thinking, Prof. H. Wildon Carr, 471
- Physics: An Ideal Text-book of, 405; and Optics, A Florentine School of, Dr. L. C. Martin, 496; Applied, The Dictionary of, Sir R. T. Glazebrook, 699; Applied, A Dictionary of, edited by Sir Richard Glazebrook: (In 5 Volumes.) Vol. I., 439. Vol. II.: Electricity, 595; Industrial, Major G. W. C. Kaye, 439; Modern, Tendencies of, Prof. C. E. Guye, 558; Practical, W. R. Bower and Prof. J. Satterly. Eighth impression (second edition), 445; Readable School, J. A. Cochrane, 340; The Teaching of, to Engineering Students, Prof. A. W. Duff, 792
- Physikalisch-Technische Reichsanstalt, Dr. Noddack appointed Director of the, 554
- Physiography of the Coal Swamps, Prof. P. F. Kendall, 353
- Physiology: and Biochemistry in Modern Medicine, Prof. J. J. R. MacLeod and others. Fourth edition, 872; of Life in the Andes, The, J. Barcroft, 152
- Physique générale, Cours de, à l'usage des candidats au certificat de Physique générale, au diplôme d'Ingénieur-Électricien et à l'Aggrégation des Sciences physiques, Prof. H. Ollivier. Tome II. Deuxième édition, 405
- Phytaloantologie und Geologie, Prof. W. Deecke, 375
- Pictures, The Preservation and Cleaning of, Prof. A. P. Laurie, 710
- Pigeon Tick, The: L. H. Matthews and A. D. Hobson, 313; A. G. Lowndes, 380
- Pigeons, Some Digestive Functions in Normal, fed with Polished Rice or kept without Food, Mme. Danysz-Michel and W. Koskowski, 200
- Pigments, Animal, Origin of, 429
- Pilot Cable, The Discovery of the, 820
- Pitdown Skull, The, E. N. Fallaize, 161
- Pipe Shrine House, Dr. J. W. Fekkes, 819
- Piperitone, Isolation and Identification of the Acid Bodies produced by the Oxidation of, by means of Potassium Permanganate, A. R. Penfold, 236
- Pituitary Body, The, 748
- Plague Bacillus, Healthy Carriers of the, M. Leger and A. Baury, 687
- Planets, Study of the Surface of, R. Jarry-Desloges, 200
- Plant: and Animal Diseases, Some Similarities and Dissimilarities in the Micro-biology of, Dr. R. M. Buchanan and Prof. V. H. Blackman, 293; Biology: a Course of Elementary Lectures on the General Morphology and Physiology of Plants, Prof. H. H. Dixon, 274; Cell, Chemistry of the, 403; Juices, The Filtration of, G. André, 300; Materials for Decorative Gardening: The Woody Plants, Prof. W. Trelease. Second edition, 177; Morphology and Physiology, \*274; Nutrition, Manganese in, J. S. McHargue, 396
- Plants: Common, Dr. M. Skene, 177; Transport of Organic Substances in, Prof. H. H. Dixon, 355, 547
- Plumbers' Handbook, S. E. Dibble, 602
- Pluralisme, Les Sciences et le, J.-H. Rosny, aîné, 541
- Poetic Mind, The, F. C. Prescott, 443
- Poland, University Education in, Prof. L. Natanson, 828
- Polarisation of Diffused Light under the Sea, E. E. Brooks, 114
- Pôle Sud, Le: Histoire des voyages antarctiques, J. Rouch, 549
- Polishing, Practical, and Staining, A. W. Parkhouse, 147
- Polonium,  $\alpha$ -Rays of, The Determination of the Velocity of, Mlle. Irène Curie, 299
- Pons-Winnecke Comet, The Meteors of the, G. Shann, 678
- Potash, S. J. Johnstone. New edition, 307
- Potassium: Carbonate, Caking of, Expansion and Shrinkage during, Prof. T. M. Lowry and E. E. Walker, 135; Cyanide, The X-ray Structure of, P. A. Cooper, 544; The Estimation of, R. L. Morris, 723; Vapour: Absorption of, in the Associated Series, Prof. A. L.



- Narayana and D. Gunnaiya, 250; The Absorption Spectrum of, S. Datta, 655
- Potato: Conference, Address to the, Dr. Salaman, 884; Trials at Ormskirk, 431; Wart Disease, Sir Daniel Hall, 431
- Potatoes: Physiology of the Dry-rot Disease of, in Storage caused by *Fusarium corymbium*, Miss E. S. Moore, 795; Wart Disease of, Prof. M. C. Potter, 563
- Pottery-making on the Blue Nile, H. A. Macmichael, 713
- Potts: Howard N., Gold Medal presented to Prof. E. G. Coker, 288; Howard N., Medal, The, awarded to Dr. C. R. Downs and J. M. Weiss, 643
- Pound Weight, Suggested Alteration of the Value of the, 52
- Poverty and its Vicious Circles, Dr. J. B. Hurry. Second edition, 177
- Powdering of Minerals by Decrepitation, Prof. T. M. Lowry and L. P. McHatton, 135
- Powders, Two Properties of, A. M. Williams, 135
- Power Transformers, High Voltage, W. T. Taylor, 506
- Practitioner and the Laboratory, The Link between the: a Guide to the Practitioner in his Relations with the Pathological Laboratory, G. Fletcher and H. McLean, 376
- Prairie Vegetation in Illinois, H. C. Sampson, 823
- Precipitation: in the United States, Prof. R. De C. Ward, 366; Effect of a Coast Line on, J. S. Dines, 235
- Pre-Devonian Geology of Great Britain, 261
- Prehistoric Antiquities, Our Homeland, and how to study them, W. G. Clarke, 510
- Prehistory for the Schoolroom, 443
- Primeval Forest, On the Edge of the: Experiences and Observations of a Doctor in Equatorial Africa, Prof. A. Schweitzer. Translated by C. T. Campion, 308
- Primitive Custom and Administration, 593
- Principia Ethica, Dr. G. E. Moore, 74
- Printing Types, The History of, 583
- Prismatic Spectra, The Law of Dispersion of, in the Ultra-violet, P. Salet, 895
- Probabilités, Essai philosophique sur les, Pierre-Simon Laplace, Dr. S. Brodetsky, 6
- Produce Markets, Organised, Prof. J. G. Smith, 404
- Progress and Science: Essays in Criticism, R. Shafer, 662
- Prominences, Kalocsa Observations of, Rev. B. G. Swindells, 678
- Protein Precipitation in Grasses, Margaret H. O'Dwyer, 759
- Protozoa and Worms parasitic in Man, Diagnosis of, Profs. R. W. Hegner and W. W. Cort, 694
- Prussian Academy of Sciences, Berlin, Prof. H. K. Onnes, Prof. P. Zeeman, and Prof. N. Bohr elected Corresponding Members of the, 158
- Psychical Monism, 24
- Psycho-analysis: and Education, Dr. C. W. Kimmins and others, 650; The Technique of, Dr. D. Forsyth, 246
- Psychology: An Introduction to, S. S. Brierley, 872; in Great Britain, The Influence of the late W. H. R. Rivers on the Development of, Dr. C. S. Myers, 392, 485
- Psychophysics as the Key to the Mysteries of Physics and Metaphysics, L. T. Troland, 24
- Public Health: On the State of the, 676; Relative Values in, Sir Arthur Newsholme, 820; Work, Compulsion and Education in, Sir Arthur Newsholme, 232
- Pultenea, Revision of the Genus, Part iii., H. B. Williamson, 563
- Pumping in the Chemical Works, N. Swindin, 726
- Pyrex Glass, 22
- Pyrogallol, Gallotannin, and Gallic Acid, The Colorimetric Estimation of, C. Ainsworth Mitchell, 722
- Pyrometers, Application of, to High Frequency Measurements, R. Jouaust, 863
- Quartz: at High Temperatures, The Elasticity and Symmetry of, A. Perrier and B. de Mandrot, 655; Crystallisation of, Heat of, R. C. Ray, 62
- Queensland, Mesozoic Insects of, No. 9, Dr. R. J. Tillyard, 864
- Quest: Movements of the, 87; Return of the, 427; The Work of the, 18
- Radiative Equilibrium, E. A. Milne, 62
- Radio: -active Disintegration, An Attempt to Influence the Rate of, by Use of Penetrating Radiation, Dr. G. Hevesy, 216; Substances, An Introduction to the Chemistry of, Dr. A. S. Russell, 477; -activity and Radio-active Substances, Dr. J. Chadwick, 412; of the Springs of the Baths of Hercules in Roumania, P. Loisel and Michalesco, 863; of the Springs of Echailion, J. Cluzet and A. Chevallier, 895; of the Springs of the Region of Bagnoles-de-l'Orne and its Relation to the Geological Structure, P. Loisel, 795; Broadcasting in Great Britain, 197, 237; Communication, 273; Direction-finding, G. Breit, 188; Effects of Local Conditions on, Smith-Rose and Barfield, 753; in Flying Machines, G. Breit, 59; for Everybody, A. C. Lescarboura. Edited by R. L. Smith-Rose, 695; Receiving for Beginners, R. T. Snodgrass and V. F. Camp, 411; Research Board and its Sub-Committee on Atmospheric, Composition of the, 675; -telephony and Broadcasting, A. P. M. Fleming, 858
- Radiography, The Principles of, Dr. J. A. Crowther, 35
- Radiolaria from Oozes, Extraction of, H. L. Thomas; A. Earland, 216
- Radiology, A State Institute of, established at Prague, 643
- Radium: Direct Estimation of very small Quantities of, by the penetrating Rays, B. Szilard, 168; Institute for the Experimental Treatment of Cancer, A. to be established by the Quebec Government, 290; Salt, a Standard, The Preparation of, M. Yovanovitch and Mlle. Chamie, 209
- Railway: Bridges, The Design of, J. S. Wilson and others, 825; Electric Traction, F. W. Carter, 338
- "Rain of Blood," The Fall of Dust called a, O. Mengel, 299
- "Rainbow": A Broadcast, Prof. R. C. McLean, 605; Peculiarity, A. L. C. W. Bonacina, 160
- Rainfall: in Southern Italy and Tripoli, Prof. F. Eredia, 60; of May and June, 88
- Rain-producing Influences in South Australia, E. T. Quayle, 586
- Rains, Heavy, in England, 259
- Ramsay Memorial: Fellowships, Award of, 199; Fund, Presentation of the Gold Medal of the, to the Prince of Wales, 745; in Westminster Abbey, The, 636
- Ranges and Cooking Appliances, Tests on, A. H. Barker, 434
- Rangoon University, D. H. Peacock appointed Professor of Chemistry and F. J. Meggett Professor of Biological Science in, 720
- Rasmussen Arctic Expedition, Work of the, 18
- Rat: Problem, The, Rodier System and the, W. Rodier, 612; The, and its Repression, Earl of Denbigh, 278
- Reale Accademia dei Lincei, Prof. E. T. Whittaker elected a Foreign Member of the, 188
- Rectangular Glass Jars, The Supply of, 19; Gallenkamp and Co., Ltd., 80
- Red: Crag Flints of Foxhall, The, J. Reid Moir, 188; S. H. Warren, 54; Lithium Line, The Structure of the, Prof. T. R. Merton, 632
- Rede Lecture for 1922, The, Dr. W. R. Inge, 104
- Refractometer, A Differential, Bellingham and Stanley, Ltd., 91
- Refrigeration, Mechanical, The Principles of, Prof. H. J. MacIntire, 36
- Relatives, Our Nearest Living, Sir Arthur Keith, 834
- Relativité, Le Principe de la, et la théorie d'Einstein, Dr. L. Bloch, 568; Prof. L.-G. du Pasquier, 568
- Relativity: and Physical Reality, Dr. A. A. Robb, 572; and the Æther, Sir Oliver Lodge, 446; Misconceptions about, 747; Paradox, A. C. C.; Prof. A. S. Eddington, 844; Special, The Time-Triangle and Time-Triad in,

- R. A. P. Rogers, 608; The Philosophical Aspects of the Principle of, Prof. A. N. Whitehead, 231; The Philosophical Importance of the Theory of, Prof. Schlick, 750; The Principle of, Profs. A. Einstein and H. Minkowski. Translated by M. N. Saha and S. N. Bose, 275; the Special Theory of, The Meaning of Rotation in, P. Franklin, 563; The Theory of, and its Influence on Scientific Thought, Prof. A. S. Eddington, 568; Prof. von Laue, 750; Summary of, Prof. H. T. H. Piaggio, 432
- Religio Chirurgi, 726
- Rennet, Vegetable, R. Hedger Wallace, 543
- Repeating Patterns as Decorations, Major P. A. MacMahon, 102
- Reptilia, the Pubi-tibialis (sartorius) Muscle of, The Innervation of, A. B. Appleton and F. Goldby, 862
- Research, Prof. A. Mair, 134; and Razors, Prof. J. R. Partington, 415; Association of British Rubber and Tyre Manufacturers, The, 297; Defence Society, Address to the, by Sir Walter Fletcher, 50; Institutes, etc., in India, Possible Reduction of Assistance to, Lord Meston, 581; in Universities, The Development of, Principal Irvine, 131; The Organisation of, Principal J. C. Irvine, 385
- Réseaux d'énergie, Construction des, M. Daval, 731
- Reservoir and other Dams, Dr. B. Cunningham, 661
- Respiration, Dr. J. S. Haldane, 803; Physiology of, J. Barcroft, 803; The Role of, in the Diminution of the Carbohydrates in Leaves during the Autumnal Yellowing, R. Combes and D. Kohler, 468
- Retzius, The Anders, Medal, 611

## REVIEWS AND OUR BOOKSHELF

**Agriculture, Forestry, and Horticulture:**

- Achariyar (Rai Bahadar K. Ranga), assisted by C. Tadulinga Mudaliyar, A Handbook of Some South Indian Grasses, 376
- Adams (Prof. R. L.), Farm Management: A Text-book for Student, Investigator, and Investor, 404
- Beccari (Dr. O.), Annals of the Royal Botanic Garden, Calcutta. Vol. 12, Parts 2 and 3, 372
- Burr (Prof. W.), Rural Organisation, 404
- Chapman (Prof. H. H.), Forest Mensuration, 407
- Dudgeon (G. C.), The Agricultural and Forest Products of British West Africa. Second edition, 210
- Erdman (Dr. H. E.), The Marketing of Whole Milk, 570
- Ernie (Lord), English Farming: Past and Present. Third edition, 204
- Francé (Dr. R. H.), Das Edaphon. Untersuchungen zur Ökologie der bodenbewohnenden Mikroorganismen. Zweite Auflage, 206
- Gamble (J. S.), A Manual of Indian Timbers: An Account of the Growth, Distribution, and Uses of the Trees and Shrubs of India and Ceylon, with Descriptions of their Wood-structure. Reprint, 276
- Hawley (Prof. R. C.), The Practice of Silviculture: With Particular Reference to its Application in the United States, 407
- Hooper (C. H.), Fruit Farming: Practical and Scientific for Commercial Fruit-growers and others. Second edition, 601
- Jackson (H.), A Short Manual of Forest Management, 407
- Keatinge (G.), Agricultural Progress in Western India, 442
- Kirkwood (J.), Farm Book-keeping: The Principles and Practice of Book-keeping applied to Agriculture: for Agricultural Colleges, Extension Classes, Evening Classes, and Practical Farmers, 768
- McCandlish (Prof. A. C.), The Feeding of Dairy Cattle, 695
- MacGarr (L.), The Rural Community, 412
- Orr (J.), A Short History of British Agriculture, 204
- Powers (W. L.) and T. A. H. Teeter, Land Drainage, 211
- Robertson (Dr. G. Scott), Basic Slags and Rock Phosphates, 306
- Schlich (Sir William), Schlich's Manual of Forestry. Vol. 1.: Forest Policy in the British Empire. Fourth edition, 407

- Smith (Prof. J. G.), Organised Produce Markets, 404
- Stone (H.), A Text-book of Wood, 73; A Guide to the Identification of our more useful Fibres: Being a Manual for the Use of Students of Forestry, 276
- Warman (W. H.), Agricultural Co-operation in England and Wales, 404

**Anthropology and Archæology:**

- Ameghino, Florentino, Obras completas y correspondencia científica de. Vol. 3, 540
- American Ethnology, Thirty-fifth Annual Report of the Bureau of, to the Secretary of the Smithsonian Institution, 1913-1914. In two parts. Part 2, 176
- Armitage (F. P.), Diet and Race: Anthropological Essays, 308
- Brown (A. R.), The Andaman Islanders: A Study in Social Anthropology, 106
- Claridge (G. C.), Wild Bush Tribes of Tropical Africa, 340
- Clarke (W. G.), Our Homeland Prehistoric Antiquities, and How to Study Them, 510
- Corréa (Prof. A. A. M.), Homo (Os Modernos Estudos sobre a origem do homem), 510
- Evans (I. H.), Among Primitive Peoples in Borneo: A Description of the Lives, Habits and Customs of the Piratical Head-hunters of North Borneo, 146
- Gregory (Prof. W. K.), The Origin and Evolution of the Human Dentition, 834
- Jenness (D.), The Life of the Copper Eskimos, 245
- Johnston (Sir Harry H.), A Comparative Study of the Bantu and Semi-Bantu Languages. Vol. 2, 67
- Malinowski (Dr. B.), Argonauts of the Western Pacific: An Account of Native Enterprise and Adventure in the Archipelagoes of Melanesian New Guinea, 472
- Melanesia, Depopulation of, Essays on the. Edited by Dr. W. H. R. Rivers, 594
- Nordenskiöld (Baron E.), The Copper and Bronze Ages of South America, 141
- Peake (H.), The English Village: The Origin and Decay of its Community. An Anthropological Interpretation, 371
- Radcliffe (W.), Fishing from the Earliest Times, 534
- Roscoe (Rev. John), Twenty-five Years in East Africa, 36
- Watkins (A.), Early British Trackways, Moats, Mounds, Camps, and Sites, 176
- Werth (Prof. E.), Der fossile Mensch: Grundzüge einer Paläanthropologie. Erster Teil, 508

**Biology:**

- Alverdes (Dr. F.), Studien an Infusorien über Flimmerbewegung, Lokomotion und Reizbeantwortung, 509
- Artschwager (Dr. E.) and E. M. Smiley, Dictionary of Botanical Equivalents: French-English, German-English, 177
- Baxter (Evelyn V.) and Leonora J. Rintoul, Some Scottish Breeding Duck: Their Arrival and Dispersal, 470
- Beebe (W.), A Monograph of the Pheasants. In four vols. Vol. III., 105; The Edge of the Jungle, 211
- Bent (A. C.), Life-histories of North American Gulls and Terns. Order Longipennes, 339
- Boulenger (Dr. G. A.), Monograph of the Lacertidæ. Vol. II., 410
- Bouvier (Prof. E. L.), translated by Dr. L. O. Howard, The Psychic Life of Insects, 402
- Bracht (Prof. A.), Traité d'embryologie des vertébrés, 275
- Collett (A.), The Changing Year, 410
- Dixon (Prof. H. H.), Practical Plant Biology: A Course of Elementary Lectures on the General Morphology and Physiology of Plants, 274
- Downing (E. R.), A Naturalist in the Great Lakes Region, 444
- Fernald (Prof. H. T.), Applied Entomology: An Introductory Text-book of Insects in their Relations to Man, 35

Flatley (F. W.) and C. L. Walton, The Biology of the Seashore, 540  
 Garstang (Prof. W.), Songs of the Birds, 209  
 Gibbs (Dr. W. E.), The Fishing Industry, 840  
 Hardenburg (W. E.), Mosquito Eradication, 838  
 Hedin (Dr. Sven), Southern Tibet: Discoveries in Former Times compared with my own Researches in 1906-1908. II. A List of Flowering Plants from Inner Asia, collected by Dr. Sven Hedin, determined by various authors, and compiled by Prof. C. H. Ostenfeld and Dr. Paulsen, 170  
 Hegner (Prof. R. W.) and Prof. W. W. Cort, Diagnosis of Protozoa and Worms Parasitic in Man, 694  
 Heron-Allen (E.) and A. Earland, British Museum (Natural History). British Antarctic ("Terra Nova") Expedition, 1910. Natural History Report. Zoology. Vol. 6, No. 2. Protozoa, Part 2: Foraminifera, 241  
 Hirst (S.), Mites Injurious to Domestic Animals (with an Appendix on the Acarine Disease of Hive Bees), 410  
 Hyman (L. H.), A Laboratory Manual of Comparative Vertebrate Anatomy, 571  
 Lundbeck (W.), Diptera Danica: Genera and Species of Flies hitherto found in Denmark. Part VI. Pipunculidae and Phoridae, 602  
 Maquenne (Prof. L.), Précis de physiologie végétale, 177  
 Microbiology, Edited by Prof. C. E. Marshall. Third edition, 694; General, Laboratory Manual in. Second edition, 694  
 Milligan (H. N.), The Horniman Museum: A Handbook to the Collections illustrating a Survey of the Animal Kingdom. Second edition, 412  
 Parker (the late Prof. T. J.) and Prof. W. A. Haswell, A Text-book of Zoology. In two volumes. Third edition, 765  
 Pearson (Prof. Karl), Francis Galton, 1822-1922: A Centenary Appreciation, 335  
 Pflanzenanatomie, Handbuch der, herausgegeben von Prof. K. Linsbauer. Allgemeiner Teil: Cytologie (Die Organe der Zelle). Band I, Zelle und Cytoplasma, Dr. H. Lundegårdh. Band 2, Allgemeine Pflanzenkaryologie, Prof. G. Tischler, 176  
 Phisalix (Dr. Marie), Animaux venimeux et venins. 2 vols., 691  
 Rettger (Prof. L. F.) and H. A. Cheplin, A Treatise on the Transformation of the Intestinal Flora, with special reference to the Implantation of Bacillus Acidophilus, 694  
 Richet (Prof. Ch.), Autorisierter Übersetzung von Dr. J. Negrin y López, Die Anaphylaxie, 694  
 Royal Society, Reports of the Grain Pests (War Committee). Nos. 1 to 10 (in 1 volume), 145  
 Rübel (Prof. E.), Geobotanische Untersuchungsmethoden, 208  
 Shann (E. W.), First Lessons in Practical Biology, 601  
 Sherborn (C. D.), Index Animalium. Sectio Secunda, 1801-1850. Part 1: Introduction, Bibliography and Index, 3  
 Simmons (A. T.) and A. J. V. Gale, A First Book of General Science: An Introduction to the Scientific Study of Animal and Plant Life, 406  
 Sirks (Dr. M. J.), Handboek der algemeene Erfelijkheidslcer, 111  
 Skene (Dr. M.), Common Plants, 177  
 Smith (K. M.) and J. C. M. Gardner, Insect Pests of the Horticulturalist: Their Nature and Control. Vol. I.: Onion, Carrot, and Celery Flies, 694  
 Swann (H. Kirke), A Synopsis of the Accipitres (Diurnal Birds of Prey). Parts 1, 2, 3. Second edition, 339  
 Thomson (Hon. G. M.), The Naturalisation of Animals and Plants in New Zealand, 868  
 Thoulet (Prof. J.), L'Océanographie, 541  
 Trelease (Prof. W.), Plant Materials of Decorative Gardening: The Woody Plants. Second edition, 177  
 Wall (Col. F.), Ophidia Toprobanica, or the Snakes of Ceylon, 538  
 Wetmore (A.), A Study of the Body Temperature of Birds, 566  
 Zoologischen Anzeiger, Herausgegeben von Prof. E. Korschelt. Register zum Zoologischen Anzeiger.

Band xxxvi.-xl., und Bibliographia Zoologica, Vol. xviii.-xxii., 245

Chemistry:

Bailey (Dr. G. H.), Edited by Dr. W. Briggs, The Tutorial Chemistry. Part 2: Metals and Physical Chemistry. 12th Impression (4th edition), 663  
 Barker (T. V.), Graphical and Tabular Methods in Crystallography as the Foundation of a New System of Practice: with a Multiple Tangent Table and a 5-Figure Table of Natural Cotangents, 629  
 Becher (Prof. S.), Untersuchungen über Echtfärbung der Zellkerne mit künstlichen Beizenfarbstoffen und die Theorie des histologischen Färbeprozesses mit gelösten Lacken, 33  
 Bernthsen (Dr. A.), new edition, revised by Prof. J. J. Sudborough, A Text-book of Organic Chemistry, 602  
 Bohu (G.) and Dr. Anna Drzewina, La Chimie et la vie, 173  
 Chamberlain (Prof. J. S.), A Text-book of Organic Chemistry, 805  
 Chemistry, Applied, Reports of the Progress of. Vol. 6, 1921, 147  
 Clarke (A.), Coal-tar Colours in the Decorative Industries, 768  
 Desch (Prof. C. H.), Metallography. Third edition, 305  
 Fabre (Prof. L.), La Séparation industrielle des solides en milieu liquide, 872  
 Fenton (Dr. H. J. H.), Notes on Qualitative Analysis: Concise and Explanatory. Supplement, 840  
 Fischer (E.), Herausgegeben von Dr. M. Bergmann, Untersuchungen über Kohlenhydrate und Fermente II. (1908-1919), 142  
 Fischer (Prof. M. H.), and others, Soaps and Proteins: Their Colloid Chemistry in Theory and Practice, 70  
 Fourneau (Prof. E.), Préparation des médicaments organiques, 69  
 Friend (Dr. J. N.), Edited by G. C. Lloyd, The Corrosion of Iron, 731  
 Grafe (Prof. V.), Chemie der Pflanzenzelle, 403  
 Griffiths (H.), Materials of Chemical Plant Construction—Non-Metals, 726; The General Principles of Chemical Engineering Design, 726  
 Hesse (Prof. A.) and Prof. H. Grossmann, Englands Handelskrieg und die chemische Industrie. Band I. Band II: Neue Folge. Band III: Herausgegeben von A. Hesse, H. Grossmann, und W. A. Roth, 337  
 Hilditch (Dr. T. P.), A Concise History of Chemistry. Second edition, 305  
 Hofmann (Prof. K. A.), Lehrbuch der anorganischen Chemie. Vierte Auflage, 695  
 Humphrey (J.), Drugs in Commerce: Their Source, Preparation for the Market, and Description, 70  
 de Kegel (M.), Les Encres, les cirages, les colles et leur préparation, 731  
 Kempton (P. H. S.), Industrial Nitrogen: The Principles and Methods of Nitrogen Fixation and the Industrial Applications of Nitrogen Products in the Manufacture of Explosives, Fertilizers, Dyes, etc., 805  
 Kewley (J.), The Petroleum and Allied Industries: Petroleum, Natural Gas, Natural Waxes, Asphalts and Allied Substances, and Shale Oils, 866  
 Lewkowsitch (Dr. J.), Chemical Technology and Analysis of Oils, Fats and Waxes. Sixth edition, entirely revised by G. H. Warburton. Vols. 1 and 2, 109  
 Lowry (Prof. T. M.), Inorganic Chemistry, 374  
 Malan (H. L.) and A. I. Robinson, The Weighing and Measuring of Chemical Substances, 726  
 Martin (Dr. G.), assisted by J. M. Dickson and Maj. J. W. Christelow, Modern Chemical Lecture Diagrams, with Uses and Applications fully described, 571  
 Mellor (Dr. J. W.), A Comprehensive Treatise on Inorganic and Theoretical Chemistry. Vols. i. and ii., 801  
 Michaelis (Prof. L.), Die Wasserstoffionen-Konzentration: ihre Bedeutung für die Biologie und die Methoden ihrer Messung. Zweite Auflage. Teil I, 305

- Ministry of Munitions and Department of Scientific and Industrial Research. Technical Records of Explosives Supply, 1915-1918. No. 5: Manufacture of Sulphuric Acid by Contact Process. No. 6: Synthetic Phenol and Picric Acid. No. 7: Manufacture of Nitric Acid from Nitre and Sulphuric Acid, 777.
- Monier-Williams (G. W.), Power Alcohol: Its Production and Utilisation, 172
- Norris (Prof. J. F.) and Prof. K. L. Mark, Laboratory Exercises in Inorganic Chemistry, 602
- Parkhouse (A. W.), Practical Polishing and Staining, 147
- Plimmer (Violet G.) and Prof. R. H. A. Plimmer, Vitamins and the Choice of Food, 336
- Purvis (J. E.) and T. R. Hodgson, The Chemical Examination of Water, Sewage, Foods, and other Substances. Second edition, 571
- Rinne (Prof. F.), Das feinhauchige Wesen der Materie nach dem Vorbilde der Kristalle. 2 und 3 Auflage, 839
- Rogers (Dr. A.), Practical Tanning, 840
- Russell (Dr. A. S.), An Introduction to the Chemistry of Radio-active Substances, 477
- Schidrowitz (Dr. P.), Recent Progress in Rubber Chemistry and Technology, 726
- Sears (Prof. G. W.), A Systematic Qualitative Chemical Analysis: A Theoretical and Practical Study of Analytical Reactions of the More Common Ions of Inorganic Substances, 477
- Sherman (Prof. H. C.) and S. L. Smith, The Vitamins, 6
- Simon (E. D.) and Marion Fitzgerald, The Smokeless City, 260
- Stillman (Prof. J. M.), Theophrastus Bombastus von Hohenheim, called Paracelsus: His Personality and Influence as Physician, Chemist, and Reformer, 202
- Swindin (N.), Pumping in the Chemical Works, 726; The Flow of Liquids in Pipes, 726
- Teichert (Dr. K.), Methoden zur Untersuchung von Milch und Molkeerzeugnissen, 110
- Thorpe (Sir Edward), A Dictionary of Applied Chemistry. Vol. 3. Revised and enlarged edition, 305
- Tutton (Dr. A. E. H.), Crystallography and Practical Crystal Measurement. Second edition. In 2 vols., 303
- Washburn (Prof. E. W.), An Introduction to the Principles of Physical Chemistry from the Standpoint of Modern Atomistics and Thermodynamics. Second edition, 305
- Wollaston (T. R.), Filtration: An Elementary Treatise on Industrial Methods and Equipment for the Filtration of Liquids and Gases for those concerned with Water Supply, Ventilation, and Public Health: Chemists, Mechanical Engineers, and Others, 663

**Engineering:**

- Allcut (Prof. E. A.) and C. J. King, Engineering Inspection, 730
- Batson (R. G.) and J. H. Hyde, Mechanical Testing: A Treatise in Two Volumes. Vol. I.: Testing of Materials of Construction, 804
- Bellasis (E. S.), Hydraulics with Working Tables. Third edition, 34
- Blattner (Dr. E.), Lehrbuch der Elektrotechnik. Erster Teil. Vierte Auflage, 176
- Booth (H.), Aeroplane Performance Calculations, 110
- Cabaud (R.), Installations électriques industrielles: choix du matériel, 474
- Carter (F. W.), Railway Electric Traction, 338
- Daval (M.), Construction des réseaux d'énergie, 731
- Dover (A. T.), Industrial Motor Control: Direct Current, 805
- Duncan (J.), An Introduction to Engineering Drawing, 476
- Eichhorn (Dr. G.), Drahtloser Übersee-Verkehr, 374
- Evans (E. A.), Lubricating and Allied Oils, 75
- Evans (E. J.), Building Contracts: The Principles and Practice of their Administration, 110
- Hayes (S. Q.), Switching Equipment for Power Control, 373

- Hydro-Electric Engineering. Vol. I.: Civil and Mechanical. Editor: Dr. A. H. Gibson. Contributors: H. D. Cook and the Editor, 108
- Lea (Prof. F. C.), Elementary Hydraulics for Technical Students, 839
- Le Gavrian (Prof. P.), Les Chaussées modernes, 272
- Lertes (Dr. P.), Die drahtlose Telegraphie und Telephonie, 273
- Lescarboura (A. C.), Edited by R. L. Smith-Rose, Radio for Everybody, 695
- Lundberg (G. C.) and the late W. P. Maycock, "Lektrik" Lighting Connections. Seventh edition, 176
- MacIntire (Prof. H. J.), The Principles of Mechanical Refrigeration, 36
- Marchant (W. H.), Marine Wireless Pocket-book for the Practical Operator and Student, 273
- Metcalf (L.) and H. P. Eddy, Sewerage and Sewage Disposal: A Text-book, 510
- Mittell (B. E. G.), Continuous Wave Wireless Telegraphy: A Non-Mathematical Introduction to the Subject of Wireless Telegraphy from the Engineer's Point of View, 273
- Newcomen Society for the Study of the History of Engineering and Technology, The, Transactions, Vol. I., 1920-21, 409
- Poole (H. E.), Switching and Switchgear, 805
- Salmon (Dr. E. H.), Columns: A Treatise on the Strength and Design of Compression Members, 210
- Smith (Dr. C. F.), The Testing of Transformers and Alternating Current Machines, 805
- Snodgrass (R. T.) and V. F. Camp, Radio Receiving for Beginners, 411
- Starling (S. G.), Electricity, 176
- Taylor (W. T.), Electric Power Systems, 506; High Voltage Power Transformers, 506
- Timbie (Prof. W. H.) and Prof. V. Bush, Principles of Electrical Engineering, 506
- Water-Power in the British Empire. The Reports of the Water-Power Committee of the Conjoint Board of Scientific Societies, 767
- Wegmann (E.), The Design and Construction of Dams: including Masonry, Earth, Rock-fill, Timber, and Steel Structures, also the Principal Types of Movable Dams. Seventh edition, 601

**Geography and Travel:**

- Bedford, A History of the County of. Part I.: Geology and Palaeontology, 339
- Brown (Dr. R. N. Rudmose), O. J. R. Howarth, and J. Macfarlane, The Scope of School Geography, 245
- Brunhes (J.) and C. Vallaux, La Géographie de l'histoire: Géographie de la paix et de la guerre sur terre et sur mer, 175
- Buchanan (A.), Exploration of Air: Out of the World North of Nigeria, 35
- Bury (Col. C. K. Howard), and others, Mount Everest: The Reconnaissance, 1921, 139
- Campbell (D.), In the Heart of Bantuland, 246
- Cisaf (J.) and F. Pokorný, The Czechoslovak Republic, 839
- Fleure (Prof. H. J.), The Peoples of Europe, 768
- Francé (Dr. R. H.), Süd-Bayern, 246
- Gordon (Seton), Amid Snowy Wastes: Wild Life on the Spitsbergen Archipelago, 597
- Howarth (O. J. R.), The World About Us: A Study in Geographical Environment, 376
- Munster. Edited by G. Fletcher, 339
- Newbigin (Dr. Marion I.), Frequented Ways: A General Survey of the Land Forms, Climates, and Vegetation of Western Europe, considered in their Relation to the Life of Man; including a Detailed Study of some Typical Regions, 599
- Rouch (J.), Le Pôle Sud: Histoire des voyages antarctiques, 540
- Schweitzer (Prof. A.), Translated by C. T. Campion, On the Edge of the Primeval Forest: Experiences and Observations of a Doctor in Equatorial Africa, 308
- Scott (J. W. R.), The Foundations of Japan: Notes

made during Journeys of 6000 Miles in the Rural Districts as a Basis for a Sounder Knowledge of the Japanese People, 538  
 Smith (Sir Ross), 14,000 Miles through the Air, 631  
 Statesman's Year-Book, The, Statistical and Historical Annual of the States of the World for the year 1922. Edited by Sir John Scott Keltie and Dr. M. Epstein, 75  
 Sweden, A Book about, 631  
 Turner (S.), The Conquest of the New Zealand Alps, 872  
 Ulster. Edited by G. Fletcher, 339  
 Varley (T.), Hampshire, 339  
 Volonakis (Dr. M. D.), The Island of Roses and her Eleven Sisters: or, the Dodecanese from the Earliest Time down to the Present Day, 146

**Geology and Mineralogy:**

Beck (Prof. R.), bearbeitet durch Dr. G. Berg, Abriss der Lehre von den Erzlagertstätten: In Anlehnung an die dritte Auflage des Lehrbuches und unter Benützung hinterlassener Aufzeichnungen, 205  
 Chautard (J.), Bibliothèque de géologie et de minéralogie appliquées: Les Gisements de pétrole, 474  
 Cole (Prof. G. A. J.), Rocks and their Origins. Second edition, 768  
 Crabtree (J. H.), Rocks and Fossils and How to Identify Them, 74  
 Cronshaw (Dr. H. B.), Oil Shales, 307  
 Dana (Prof. E. S.), Third edition, revised and enlarged by Prof. W. E. Ford. A Text-book of Mineralogy: With an extended Treatise on Crystallography and Physical Mineralogy, 210  
 Deecke (Prof. W.), Phytopaläontologie und Geologie, 375  
 Emmons (Prof. W. H.), General Economic Geology: A Text-book, 210  
 Grabau (Prof. A. W.), A Text-book of Geology, 2 parts, 143  
 Gregory (Prof. J. W.), Evolution of the Essex Rivers and of the Lower Thames, 308  
 Hayes (Dr. C. W.), Handbook for Field Geologists. Third edition, 412  
 Hobbs (Prof. W. H.), Earth Evolution and its Facial Expression, 270  
 Johnstone (S. J.), Potash. New edition, 307  
 Jones (Dr. O. T.), Memoirs of the Geological Survey. Special Reports on the Mineral Resources of Great Britain. Vol. 20: Lead and Zinc. The Mining District of North Cardiganshire and West Montgomeryshire, 476  
 Lang (Dr. W. D.), Catalogue of the Fossil Bryozoa (Polyzoa) in the Department of Geology, British Museum (Natural History). The Cretaceous Bryozoa (Polyzoa). Vol. 4: The Cribrimorphs. Part 2, 445  
 Leith (C. K.), The Economic Aspects of Geology, 143  
 Martel (E.-A.), Nouveau Traité des eaux souterraines, 242  
 Milner (H. B.), An Introduction to Sedimentary Petrography: with special reference to loose Detrital Deposits and their Correlation by Petrographic Methods, 804  
 Mitzakis (M.), The Oil Encyclopedia, 474  
 Moon (F. W.), and H. Sadek, Topography and Geology of Northern Sinai, 175  
 Peel (R.), Twentieth edition, revised and enlarged by Prof. D. Burns, An Elementary Text-book of Coal-Mining, 628  
 Penzer (N. M.), The Mineral Resources of Burma, 74;  
 The Tin Resources of the British Empire, 5  
 Pogue (J. E.), The Economics of Petroleum, 474  
 Quennell (M. and C. H. B.), Everyday Life in the Old Stone Age, 443  
 Reed (Dr. F. R. C.), The Geology of the British Empire, 5  
 Reeves (J.), The World-Story of 3,000,000,000 (?) years, 443  
 Rogers (Dr. A. W.), The Geology of the Country around Heidelberg and Geological Map of the Country around Heidelberg, 662  
 Underhill (Dr. J.), Mineral Land Surveying. Third edition, 541  
 Wegener (Dr. A.), Die Entstehung der Kontinente und Ozeane. Dritte Auflage, 798

Whitaker (W.), The Water Supply of Cambridgeshire, Huntingdonshire, and Rutland from Underground Sources, 7  
 Wilson (G. V.), and others, Special Reports on the Mineral Resources of Great Britain. Vol. 2: Barytes and Witherite. Third edition, 211  
 Wray (D. A.), The Geology and Mineral Resources of the Serb-Croat-Slovene State: Being the Report of the Geologist attached to the British Economic Mission to Serbia, 33

**Mathematical and Physical Science:**

Barnard (Prof. R. J. A.), Elementary Statics of Two and Three Dimensions, 243  
 Barus (Prof. C.), Displacement Interferometry applied to Acoustics and to Gravitation, 7  
 Biologischen Arbeitsmethoden, Handbuch der, herausgegeben von Prof. E. Abderhalden. Lief. 55. Abt. V. Teil 6, Heft 3, 509  
 Bisacre (F. F. P.), Applied Calculus: An Introductory Text-book, 411  
 Bloch (Dr. L.), Le Principe de la relativité et la théorie d'Einstein, 568  
 Bosovich (R. J.), A Theory of Natural Philosophy. Latin-English edition. With a short Life of Bosovich, 870  
 Bower (W. R.) and Prof. J. Satterly, Practical Physics. Eighth impression (second edition), 445  
 Campbell (Dr. N. R.), Modern Electrical Theory. Supplementary Chapters. Chapter XV.: Series Spectra, 767  
 Capstick (Dr. J. W.), Sound: An Elementary Text-book for Schools and Colleges. Second edition, 510  
 Chadwick (Dr. J.), Radioactivity and Radioactive Substances, 412  
 Chauveau (B.), Électricité atmosphérique. Premier fasc.: Introduction historique, 406  
 Cisotti (Prof. U.), Idromeccanica Piana. Parte Prima and Parte Seconda, 243  
 Clapham (C. B.), Metric System for Engineers, 340  
 Cochrane (J. A.), Readable School Physics, 340  
 Comstock (Prof. G. C.), Observations of Double Stars, 1907-1919, 7  
 Crowther (Dr. J. A.), Ions, Electrons, and Ionising Radiations. Third edition, 340  
 Dakin (A.), Practical Mathematics. Part I., 375  
 Davidge (H. T.) and R. W. Hutchinson, Technical Electricity. Fourth edition, 840  
 Doublet (E.), Histoire de l'astronomie, 600  
 Dunk (J. L.), Hyperacoustics. Division II.: Successive Tonality, 411  
 Eddington (Prof. A. S.), Ouvrage traduit de l'anglais par J. Rossignol, Espace, Temps et Gravitation: la théorie de la relativité généralisée dans ses grandes lignes, 410; The Romanes Lecture, 1922. The Theory of Relativity and its Influence on Scientific Thought, 568  
 Einstein (Prof. A.) and Prof. H. Minkowski. Translated by M. N. Saha and S. N. Bose, The Principle of Relativity, 275  
 Fowler (Prof. A.), The Physical Society of London. Report on Series in Line Spectra, 690  
 Günther (H.), (W. de Haas), Technische Träume, 663  
 Haag (Prof. J.), Cours complet de mathématiques spéciales. Tome 2, Géométrie, 375  
 Hale (Prof. G. E.), The New Heavens, 2  
 Hicks (Prof. W. M.), A Treatise on the Analysis of Spectra: Based on an Essay to which the Adams Prize was awarded in 1921, 690  
 Humbert (Prof. P.), Introduction à l'étude des fonctions elliptiques à l'usage des étudiants des facultés des sciences, 308  
 Janet (Prof. P.), Problèmes et exercices d'électricité générale, 147  
 Laplace (Pierre-Simon), Essai philosophique sur les probabilités, I., II., 6  
 London Mathematical Society, Proceedings of the, Second Series. Vol. 20, 570  
 Love (Prof. A. E. H.), Theoretical Mechanics: An

- Introductory Treatise on the Principles of Dynamics, with Applications and Numerous Examples. Third edition, 243
- Malet (H.), Étude géométrique des transformations birationnelles et des courbes planes, 276
- Mallik (Prof. D. N.), The Elements of Astronomy, 731
- McClean (Capt. W. N.), Land and Sea Speed Reckoner, 308
- Mills (J.), Within the Atom: A Popular View of Electrons and Quanta, 246
- Moreux (l'Abbé Th.), Origine et formation des mondes, 660; Pour comprendre Einstein, 568
- Mulder (Prof. M. E.), The "Green Ray" or "Green Flash" (Rayon Vert) at Rising and Setting of the Sun, 370
- Occhialini (A.), Elettrotecnica elementare con numerosi problemi. Vol. 1, 474
- Ollivier (Prof. H.), Cours de physique générale à l'usage des candidats au certificat de Physique générale, au diplôme d'Ingénieur-Électricien et à l'Aggrégation des Sciences physiques. Tome Second: Thermodynamique et étude de l'énergie rayonnante. Deuxième édition, 405
- Page (Prof. L.), An Introduction to Electrodynamics: From the Standpoint of the Electron Theory, 509
- du Pasquier (Prof. L.-G.), Le Principe de la relativité et les théories d'Einstein, 568
- Physics, Applied, A Dictionary of. Edited by Sir Richard Glazebrook (In 5 Volumes). Vol. I.: Mechanics, Engineering, Heat, 439; Vol. II.: Electricity, 595
- Planck (Prof. Max), Einführung in die Theorie der Elektrizität und des Magnetismus. Zum Gebrauch bei Vorträgen, sowie zum Selbstunterricht, 474; Vorlesungen über Thermodynamik. Sechste Auflage, 207
- Poirée (J.), Précis d'arithmétique, 445
- Raman (Prof. C. V.), Molecular Diffraction of Light, 505
- Rohr (Dr. M. von), Rendered into English by Dr. A. H. Levy, Eyes and Spectacles, 376
- Rouch (Prof. J.), Manuel d'occamographie physique, 840
- Rouger (Prof. L.), Translated by Prof. M. Masius, Philosophy and the New Physics: An Essay on the Relativity Theory and the Theory of Quanta, 568
- Strasser (Prof. H.), Die Grundlagen der einsteinischen Relativitätstheorie: Eine kritische Untersuchung, 568
- Tweedie (C.), James Stirling: A Sketch of his Life and Works, along with his Scientific Correspondence, 111
- Wolfe (W. S.), Graphical Analysis: A Text-book on Graphic Statics, 412
- Medical Science:**
- Blanchard (Dr. Phyllis), The Care of the Adolescent Girl: a Book for Teachers, Parents, and Guardians, 411
- Colwell (Dr. H. A.), An Essay on the History of Electrotherapy and Diagnosis, 32
- Crowther (Dr. J. A.), The Principles of Radiography, 35
- Cummer (Prof. C. L.), A Manual of Clinical Laboratory Methods, 731
- Donders (F. C.), Reden gehalten bei der Enthüllung seines Denkmals in Utrecht, am 22. Juni 1921. Von Prof. C. A. Pekkelharig, Dr. Sikkell, Dr. A. F. Baron van Lijnden, Dr. J. P. Fockema Andreae, aus dem Holländischen übersetzt von Paula Kraiss-geb. Engelmann, 147
- Fletcher (C.) and H. McLean, The Link between the Practitioner and the Laboratory: a Guide to the Practitioner in his Relations with the Pathological Laboratory, 376
- Forsyth (Dr. D.), The Technique of Psycho-analysis, 246
- Haldane (Dr. J. S.), Respiration, 803
- Handley (Prof. W. S.), Cancer of the Breast and its Treatment. Second edition, 376
- Harrow (Dr. B.), Glands in Health and Disease, 658
- Influenza: Essays by several authors. Edited by Dr. F. G. Crookshank, 30
- Keynes (Dr. G.), Blood Transfusion, 871
- Little (E. M.), Artificial Limbs and Amputation Stumps: a Practical Handbook, 805
- MacLeod (Prof. J. J. K.), assisted by R. G. Pearce, A. C. Redfield, and N. B. Taylor. Fourth edition: Physiology and Biochemistry in Modern Medicine, 872
- Mann (Dr. J. D.), Sixth edition, revised by Dr. W. A. Brend, Forensic Medicine and Toxicology, 571
- Martin (Prof. A. S.) and Dr. C. V. Weller, The Medical Aspects of Mustard Gas Poisoning, 32
- Mitchell (Dr. T. W.), The Psychology of Medicine, 412
- Parsons (A. C.), Dr. A. S. MacNalty, and J. R. Perdrau, Report on Encephalitis lethargica, 626
- Pope (Amy E.), Pope's Manual of Nursing Procedure, 445
- Singer (Dr. C.), Greek Biology and Greek Medicine, 631; The Discovery of the Circulation of the Blood, 602
- Smith (H. M.), Gaseous Exchange and Physiological Requirements for Level and Grade Walking, 728
- Vincent (Prof. Swale), Internal Secretion and the Ductless Glands. Second edition, 658
- War, History of the Great, based on Official Documents. Medical Services: Diseases of the War. Vol. I. Edited by Maj.-Gen. Sir W. G. MacPherson and others, 729
- Wolbach (Prof. S. B.), New Growths and Cancer, 766
- Metallurgy:**
- Aitchison (Dr. L.), Engineering Steels, 537
- Austin (L. S.), The Metallurgy of the Common Metals: Gold, Silver, Iron (and Steel), Copper, Lead, and Zinc. Fifth edition, 71
- Breary (H.), The Case-hardening of Steel: an Illustrated Exposition of the Changes in Structure and Properties induced in Steels by Cementation and Allied Processes. Second edition, 537
- Cronshaw (Dr. H. B.), Imperial Institute: Monographs on Mineral Resources with Special Reference to the British Empire: Silver Ores, 477
- Hughes (W. E.), On the Electro-deposition of Iron, 445
- Iron and Steel, The Metallurgy of, based mainly on the Work and Papers of Sir Robert A. Hadfield, 507
- Urquhart (J. W.), Steel Thermal Treatment, 837
- Whiteley (B.), Iron-founding, 537
- Meteorology:**
- Richardson (L. F.), Weather Prediction by Numerical Process: Forms whereon to write the Numerical Calculations described in "Weather Prediction by Numerical Process," 762
- Shaw (Sir Napier), Air Ministry: Meteorological Office. The Weather Map. An Introduction to Modern Meteorology. Fifth issue (Reprint of fourth), 768
- Miscellaneous:**
- Annual Register, The, A Review of Public Events at Home and Abroad for the Year 1921, 75
- Barber (Prof. F. D.) and others, First Course in General Science, 406
- Beck (C.), The Microscope: a Simple Handbook, 147
- Bell (Dr. L.), The Telescope, 627
- British Labour: Replacement and Conciliation, 1914-21: being the Result of Conferences and Investigations by Committees of Section F of the British Association. Part 1, on Replacement, Co-ordinated and Revised by Miss L. Grier and Miss A. Ashley; Part 2, on Conciliation, Edited by A. W. Kirkaldy, 145
- British Museum (Natural History), Catalogue of the Books, Manuscripts, Maps, and Drawings in the. Vol. 6, Supplement: A-I, 540
- Campbell (Dr. Norman), What is Science? 728
- Caulley (Prof. M.), Translated by J. H. Woods and E. Russell, Universities and Scientific Life in the United States, 72
- Contemporary Science, Edited, with an Introduction, by W. B. Harrow, 111

Eikenberry (Prof. W. L.), The Teaching of General Science, 731  
 Foster (Sir Gregory), The University of London (History, Present Resources and Future Possibilities), 240  
 Frederick (Mrs. C.), Scientific Management in the Home: Household Engineering, 177  
 Garnett (Dr. W.), A Little Book on Water Supply, 275  
 Gordon (Mary), Penal Discipline, 692  
 Homework and Hobby Horses, Edited by H. C. Cook, 211  
 Howarth (O. J. R.), The British Association for the Advancement of Science: a Retrospect, 1831-1921, 302  
 Hull and the East Riding of Yorkshire, Handbook to, prepared for the Members of the British Association for the Advancement of Science on the Occasion of their Visit to Hull in September 1922, Edited by T. Sheppard, 539  
 Hurry (Dr. J. B.), Poverty and its Vicious Circles. Second edition, 177  
 Inge (Dr. W. R.), The Victorian Age: The Rede Lecture for 1922, 104  
 Lethaby (W. R.), G. L. Pepler, Sir T. G. Chambers, R. Unwin, and R. L. Reiss, Edited, with an Introduction, by C. B. Purdom, Town Theory and Practice, 307  
 MacNaughten (H.), Émile Coué: The Man and his Work, 376  
 Manchester University Roll of Service, 111  
 Modern Science, Problems of, Edited by Prof. A. Dendy, 409  
 Picard (É.), Discours et mélanges, 629  
 Redgrove (H. S.) and I. M. L. Redgrove, Joseph Glanvill and Psychical Research in the Seventeenth Century, 36  
 Rhodes (R. C.), The Stager of Shakespeare, 36  
 Roper (R. E.), The Individual and the Community, 340  
 Science, The Advancement of, 1922. Addresses delivered at the 90th Annual Meeting of the British Association for the Advancement of Science, Hull, September 1922, 507  
 Shafer (R.), Progress and Science: Essays in Criticism, 662  
 Van Buskirk (E. F.) and E. L. Smith, The Science of Everyday Life, 406  
 Walker (J. E.) and R. B. Foster, Patents for Inventions, 663  
 Wells (H. G.), A Short History of the World, 867  
 White (E. G.), The Voice Beautiful in Speech and Song: a Consideration of the Capabilities of the Vocal Cords and their Work in the Art of Tone Production. Third edition, 871

**Philosophy and Psychology:**

Aristotle, The Works of, translated into English. De Caelo, by J. L. Stocks; De Generatione et Corruptione, by Prof. H. H. Joachim, 174  
 Bergson (Prof. H.), Durée et simultanéité: A propos de la théorie d'Einstein, 503  
 Brierley (S. S.), An Introduction to Psychology, 872  
 Brooks (H. Jamyn), Universal Problems, 804  
 Brunshvich (Prof. L.), L'Expérience humaine et la causalité physique, 471  
 Cabot (Ella L.), Seven Ages of Childhood, 872  
 Edman (Dr. I.), Human Traits and their Social Significance, 146  
 Firth (Violet M.), The Machinery of the Mind, 146  
 Giddings (Prof. F. H.), Studies in the Theory of Human Society, 571  
 Goddard (H. H.), Juvenile Delinquency, 477  
 Haldane (Viscount), The Philosophy of Humanism and of other Subjects, 471  
 Jackson (Dr. Josephine A.) and Helen M. Salisbury, Outwitting our Nerves: A Primer of Psychotherapy, 477  
 Kennedy (B.), Thought-Coin, 147  
 Kidd (B.), A Philosopher with Nature, 836  
 Lange (C. G.) and W. James, The Emotions, 730  
 McCall (Prof. W. A.), How to Measure in Education, 601

McTaggart (Dr. J. McT. E.), Studies in the Hegelian Dialectic, 208  
 Micklem (E. R.), Miracles and the New Psychology: A Study in the Healing Miracles of the New Testament, 630  
 Moore (Prof. G. E.), Principia Ethica, 74  
 Nys (Prof. D.), La Notion d'espace, 471  
 Ogden (C. K.), I. A. Richards, and J. Wood, The Foundations of Aesthetics, 375  
 Prescott (F. C.), The Poetic Mind, 443  
 Reyburn (Prof. H. A.), The Ethical Theory of Hegel: A Study of the Philosophy of Right, 70  
 Rosny, aîné (J.-H.), Les Sciences et le pluralisme, 541  
 Sellars (Prof. R. W.), Evolutionary Naturalism, 631  
 Shann (G.), The Evolution of Knowledge, 471  
 Shuttleworth (Dr. G. E.) and Dr. W. A. Potts, Mentally Deficient Children: their Treatment and Training. Fifth edition, 663  
 Stekel (Dr. W.), Translated by Rosalie Gabler, The Beloved Ego: Foundations of the New Study of the Psyche, 805  
 Stephen (K.), The Misuse of Mind: A Study of Bergson's Attack on Intellectualism, 541  
 Tilby (A. W.), The Evolution of Consciousness, 147  
 Walston (Waldstein) (Sir Charles), Harmonism and Conscious Evolution, 443  
 Warren (Prof. H. C.), A History of the Association Psychology, 75

**Technology:**

Barker (Prof. A. F.) and others, Textiles. Revised edition, 272  
 Deerr (N.), Cane Sugar: A Text-book on the Agriculture of the Sugar Cane. The Manufacture of Cane Sugar, and the Analysis of Sugar-house Products. Second edition, 4  
 Dibble (S. E.), Plumbers' Handbook, 602  
 Gaschet (H.), Manuel de tournage du bois, 510  
 Jones (L.) and F. I. Scard, The Manufacture of Cane Sugar. Second edition, 4  
 King (W.), Chelsea Porcelain, 871  
 Murke (Dr. F.), Condensed Description of the Manufacture of Beet Sugar, 4  
 Taggart (W. Scott), Cotton Spinning. Vol. II. Sixth edition, with Appendix, 75  
 Watson (W.), Textile Design and Colour: Elementary Weaves and Figured Fabrics. Second edition, 74

*Revista: de Ciencias*, 363; *Mensal de Meteorologia*, No. 1,

52  
 Rhinanthine and Aucubine, M. Bridel and Mlle. Marie Braecke, 655  
*Rhinanthus Crista-Galli*, Seeds of, Presence of Aucubine and of Saccharose in the, M. Bridel and Mlle. Marie Braecke, 623  
*Rhinosporidium seeberi*, with Special Reference to its Sporulation and Affinities, Prof. J. H. Ashworth, 723  
 Rhodes Trust, Annual Report for 1921-22, 860  
 Rice, Fungal Diseases of, 823  
 Richardson Gyro-magnetic Effect, The, Prof. A. P. Chattock and L. F. Bates, 721  
 Kicketts: The Cause of, Dr. L. Findlay; Dr. Chick, and others, 137; Sir W. M. Bayliss; The Writer of the Article, 212; The Etiology of, Dr. L. Findlay and Prof. Mellanby, 294  
 Riemann, The Law of, the Perihelion of Mercury, and the Deviation of Light, G. Bertrand, 167  
 River Discharge Measurements, Improved, E. B. H. Wade, 495  
 Roche's Limit for Satellites, Dr. E. O. Fountain, 89; Prof. J. Joly, 179  
 Rock: Carvings and Inscribed Symbols of the Neolithic and Bronze Ages, Prof. R. A. S. Macalister, 852; -desert, A, 175; -formation, Processes of, J. H. Goodchild, 589  
 Rockall, The Structure of, Prof. J. B. Charcot, 90  
 Rockefeller Foundation, Report of the, for 1921, 52

- Rocks: and Fossils and how to Identify them, J. H. Crabtree, 74; and their Origins, Prof. G. A. J. Cole. Second edition, 768
- Rocky Mountain Oil-field, The, W. T. Thorn, jr., 714
- Roman: Antiquities, Some, A. M. Woodward; C. D. Chambers, 748; Balance in South America, The, Baron E. Nordenskiöld, 526; Remains in London, W. C. Edwards, 556
- Romanes Lecture, Prof. Eddington's, E. Cunningham, 568
- Root Respiration, 58
- Roots: of Crop Plants, Development and Activities of, Prof. J. E. Weaver, F. C. Jean, and J. W. Crist, 887; The Respiration of the, J. Stoklasa, 831
- Roses, The Island of, and her Eleven Sisters: or, The Dodecanese from the Earliest Time down to the Present Day, Dr. M. D. Volonakis, 146
- Rowett Institute of Research in Animal Nutrition, opened by the Queen, 393, 464
- Royal: Aeronautical Society, Prof. L. Baird elected Chairman of the, 50; Botanic Garden, Calcutta, Annals of the, Vol. 12, Parts 2 and 3, Dr. O. Beccari, 372; Gardens, The, Kew, 423; Society, *Quarterly Summary* of the, 746; Society's Gardens, The, 185; College of Science, Dublin, The Position and Prospects of the, 610, 814; Dutch Institute of Engineers, Sir Charles Parsons, Dr. J. H. Tudsbury, and C. le Maistre elected Honorary Members of the, 188; Institute of British Architects, Award of Dawney Scholarships, 233; Institution, Sir Arthur Keith elected Secretary of the; Profs. Urban, Ehrenfest, Knudsen and Bjerknes, and Dr. I. Langmuir elected Honorary Members of the, 784; Observatory, The, Greenwich, 356; Photographic Society's Exhibition, The, 498; Sanitary Institute, The Congress of the, 232; Scholarships and Free Studentships, 1022; Successful Candidates in the Open Competition for, 621; Scottish Geographical Society, The Gold Medal of the, awarded to Prof. J. W. Gregory, 675; Scottish Museum, Edinburgh, E. L. Gill appointed an Assistant at the, 427; Society, Anniversary Dinner, 781; Anniversary Meeting, Presentation of Medals, 787; Conversazione, The Second, 23; Council, Members recommended for Election to the, 647; Medals, Award of the, 674; Reports of the Grain Pests (War) Committee, Nos. 1 to 10, 145; for the Protection of Birds, Bequest to the, by W. H. Hudson, 711; of Arts, Albert Medal of the, presented to Sir Dugald Clerk, 50; of Edinburgh, James Scott Prize of the, presented to Prof. A. N. Whitehead, 50; Prize Awards of the, to Prof. R. A. Sampson and Sir E. Sharpey Schafer, 19
- Rubber: and Tyre Manufacturers, The Research Association of British, 297; Chemistry and Technology, Recent Progress in, Dr. P. Schidrowitz, 726
- Rudbeckia and Aquilegia, Prof. T. D. A. Cockerell, 278
- Rugose Corals from the Burindi Series (Lower Carboniferous) of N.S.W., W. N. Benson and D. Smith, 62
- Rural: Community, The, L. MacGarr, 412; Organization, Prof. W. Burr, 404; Schools, Home Economics in, 755
- Russia: Medical Men in, Appeal for Help for, 883; The Needs of Engineers in, 818
- Russian: Men of Science, Relief for Distressed, 492; Names, Transcription of, Maj.-Gen. Lord Edward Gleichen, 78, 635; C. A. Hoare, 279; J. G. F. Druce and A. Glazunov, 512; J. H. Reynolds, 635; Universities, Life To-day in, H. Gibson, 755
- Saccharose, The Tritoluminescence Spectrum of, H. Longchambon, 136
- Saccocirrus and Protodrilus, On the Occurrence of the Archannelids, on the South and West Coasts of England, Dr. J. H. Orton, 574
- Sachs-Georgi and the Wassermann Reactions, The Serum Constituents responsible for the, T. J. Mackie, 832
- Safeguarding of Industries Act, The, 818
- Sahara, Danish Expedition to the, led by Prof. Olufsen, 643
- Salters' Institute of Industrial Chemistry, Award of Fellowships of the, 368
- Sand: The Apparent Swelling of, on the Addition of Water, L. E. Norton, 63; -blasted and Ground Glass Surfaces, Comparison of the Structure of, F. W. Preston, 591
- Sanitation, General and Specific, 169
- Satellites and Minor Planets, The Orbital Distances of, Prof. G. Armellini, 260
- Saw-flies, Pairing and Parthenogenesis in, A. D. Peacock, 215
- Scabious, An unusual, N. L. Silvester, 188
- Scandinavia: Temperature in, The Distribution of, H. E. Hamberg, 557; The Ethnology of, Prof. H. F. Osborn, 190
- Science Abstracts, W. R. Cooper appointed Editor of, 493
- Science: and Education at South Kensington, T. Ll. Humberstone, 79; and Progress, 662; and Research, A National Focus of, Dr. G. E. Hale, 676; and the Empire, 797; Major A. G. Church, 876; Editor, 877; and the Laity, The Need of an Interpreter between, Prof. A. L. Bowley, 320; and the Scriptures, Dr. W. W. Keen, 726; British, Ninety Years of, 302; Contemporary, Edited, with an Introduction, by W. B. Harrow, 111; Educational and School, Sir Richard Gregory, 355, 420; General, A First Book of, An Introduction to the Scientific Study of Animal and Plant Life, A. T. Simmons and A. J. V. Gale, 406; First Course in, Prof. F. D. Barber and others, 406; The Teaching of, Prof. W. L. Eikenberry, 731; in Egypt, Col. H. G. Lyons, 283; in Schools and Colleges, The Teaching of, Sir William Tilden and others, 754; Modern, Problems of, Edited by Prof. A. Dendy, 499; of Everyday Life, The, E. F. Van Buskirk and E. L. Smith, 406; Primers, C. L. Bryant, 406; The Advancement of, 1922, 507; The Influence of, Sir G. Greenhill, 78; Rev. A. L. Cortie, 180, 378; Sir Oliver Lodge, 277; The Nature of, 728; The Philosophy of, or the Principles of Scientific Procedure, Sir Oliver Lodge, 887; What is? Dr. Norman Campbell, 728
- Scientia, an Inquiry in, into the Einstein Theories, 885
- Scientific: Advance, Thoughts on, 409; and Industrial Pioneers, Eng.-Capt. E. C. Smith, 846; Research, Some Aspects of, Prof. R. F. Rutan, 130; Instruments, Historical, Exhibition of, at Oxford, 783; Management in the Home: Household Engineering, Mrs. C. Frederick, 177; Problems and Progress, 352; Societies, The Need for Co-operation between, the late Dr. W. H. R. Rivers, 493
- Scorpions and their Venom, Major C. E. F. Mouat-Biggs, 250
- Scottish: Breeding Duck, Some, Their Arrival and Dispersal, Evelyn V. Baxter and Leonora J. Rintoul, 476; People, The Stature of the, Sir Arthur Keith, 8
- Sea: -bottom, The Fauna of the, Dr. C. G. J. Petersen, 527; Life in the, The Progression of, Dr. E. J. Allen, 353, 448
- Seal Cylinders, The Oldest-dated, L. Legrain, 462
- Seashore, The Biology of the, F. W. Flattely and C. L. Walton, 540
- Secondary Schools: Geography in, 466; Home Economics in, Reorganization of, 755
- Secretaries, The Duties of, P. L. Marks, 51
- Seeds, The Catalogue of, J. de Vilmorin and Cazaubon, 200
- Selacians, The Spincther of the Iris in the, L. Carrere, 468
- Selborne Society, Cinematograph Lectures of the, 884
- Selective Coloration of the Nervous System in some Invertebrates, A Method of, M. Romieu, 532
- Selenium, The Isotopes of, and some other Elements, Dr. F. W. Aston, 664
- Semi-Diesel Engine, The, A. Schubert, 191
- Sensitizers for the Extreme Red, Drs. C. E. K. Mees and G. Gutekunst, 366
- Sentiments and Complexes, The Relations between, the late Dr. Rivers and others, 231
- Serb-Croat-Slovene State, The Geology and Mineral Resources of the, D. A. Wray, 33
- "Seuil différentiel," The Idea of the, and Progressive Masculinisation of certain Female Birds, A. Pézard, 290
- Sewerage and Sewage Disposal: A Text-book, L. Metcalf and H. P. Eddy, 510



- Sex: Change in Mollusca, Prof. J. Bronté Gatenby, 544; Economics, Mrs. B. Wootton, 533
- Shakespeare, The Stagnery of, R. C. Rhodes, 36
- Shear, Constants of a, The Graphical Construction of the, Prof. H. Hilton, 100
- Sheep, Poisoning of, by *Solanum cinereum*, S. Dodd, 592
- Sheffield: Scientific School, Yale University, Retirement of Dr. R. H. Chittenden as Director; succeeded by Dr. C. H. Warren, 60; University, Conferment of Honorary Degrees, 60; Prof. A. H. Leahy appointed Emeritus Professor of Mathematics, R. Platt appointed Demonstrator in Pathology and Bacteriology, 562; R. Stoneley appointed Curator of the Observatory, 684
- Shipping Casualties and Loss of Life at Sea, Statistics of, J. W. Verdier, 51
- Sideral System, The Arrangement and Motion of the, Prof. Kapteyn, 103
- Sierra Leone, The Geology of, F. Dixey, 757
- Silicates and the Silicic Acids, The Magnetic Analysis of, P. Pascal, 758
- Silicosis of the Lungs, Experimental, A. Mavrogordato, 366
- Silk, Acetate, Colouring Matters for Dyeing, Prof. A. G. Green, 743
- Silver: Bromide-Gelatin Plates, The Desensitising of, Dr. T. Slater Price, 849; Ores, Dr. H. B. Cronshaw, 477; -plated Work, The Cause of Red Stains on, A. Jefferson, 531
- Silviculture, The Practice of, with Particular Reference to its Application in the United States, Prof. R. C. Hawley, 407
- Sinai, Northern, Topography and Geology of, Part 6, F. W. Moon and H. Sadek, 175
- Singing Flame, The Theory of the, E. G. Richardson, 829
- Sirius, The Orbit of, C. P. Howard, 461
- Sison Ammi*, Linn., The Identification of, T. A. Sprague, 27
- Size, The Inheritance of, 463
- Skjellerup's Comet, Mr. Davidson, 89; G. Merton, 160; 1922b, Dr. W. H. Steavenson, 20; Ephemeris of, 53; 1922d, Observations of the, A. Schumasse, 295
- Smallpox and Vaccination, 725
- Smell: in Birds, Sense of, C. B. Williams, 149; Prof. A. Meek, 279; Dr. B. S. Neuhausen, 677; Lt.-Col. W. E. McKechnie, 784; The Organs and Sense of, and of Odorous Substances, Bibliography of, J. H. Kenneth, 427
- Smithsonian Institution, Exploration and Field-work of the, 1921, 677
- Smoke: Abatement Bill, The New, Prof. J. B. Cohen, 269; of Cities, The, Prof. A. E. Boycott, 413; Prof. J. B. Cohen, 414
- Smokeless: City, The, E. D. Simon and Marion Fitzgerald, 269; Methods in Glasgow Housing Schemes, W. B. Smith, 232
- Snowdonia, The Lavas of, H. Williams, 888
- Snowy Wastes, Amid, Wild Life on the Spitsbergen Archipelago, S. Gordon, 597
- Soaps and Proteins, Their Colloid Chemistry in Theory and Practice, Prof. M. H. Fischer and others, 70
- Social: Beetles in British Guiana, A Study of some, and of their Relations to the Ant-Plant *Tachigalia*, Prof. W. M. Wheeler, 95; Sciences, Correlation of the, J. S. Marvin and others, 682
- Sodammonium: The Action of, on Hexamethylene-tetramine, etc., M. Picon, 686; with Hydrocarbons, The Reactions furnished by, P. Lebeau and M. Picon, 299
- Soil: -acidity, Experiments on the Theory of, Prof. J. N. Mukherjee, 732; Arable, The Presence of Cobalt and Nickel in, G. Bertrand and Mokragatz, 235; The Bacterial and Protozoan Population of the, D. W. Cutler, L. M. Crump, and H. Sandon, 26; The Living, 206
- Solar: Atmospheric Changes, Dr. W. J. S. Lockyer; A. M. Newbegin; C. P. Butler, 20; Eclipse, The Total, of September 21, Dr. A. C. D. Crommelin, 389, 457; Radiation and its Changes, Dr. C. G. Abbot, F. E. Fowle, and L. B. Aldrich, 608; at Helwan Observatory, 790; Observations of, 1915-1921, H. Knox-Shaw, 790; Rotation, The Law of, Dr. Hahn, 428
- Solenoids, Skin Effect in, G. Breit, 668
- Solides en milieu liquide, La Séparation industrielle des, Prof. L. Fabre, 872
- Solifluxion, The Rôle of the Phenomena of, in the Model of the Region of Saulieu (Morvan), Mlle. F. Brepson, 686
- Solution, The Problem of, 470
- Sonometer, An Optical, Adam Hilger, Ltd., 464
- Sophocles, The Statue of, in the Lateran Museum, T. Reinach, 494
- Sound: Absolute Measurements of, Prof. A. G. Webster, 42; Amplifier, A New, L. Gaumont, 863; An Elementary Text-book for Schools and Colleges, Dr. J. W. Capstick. Second edition, 510; Standard Source of, The Production of a, Capt. E. T. Paris, 378
- South: Africa, Parasitology in, Dr. A. Porter; Prof. H. B. Fantham, 90; Problems of Race and Nationality in, Dr. J. E. Duerden, 21; Some Protozoa found in Soils in, Prof. H. B. Fantham, 831; The Union of, Department of Mines and Industries: The Geology of the Country around Heidelberg: Geological Map of the Country around Heidelberg, Dr. A. W. Rogers, 662; African Geology, A Bibliography of, to the End of 1920, A. L. Hall, 677; Larval Trematodes and the Intermediary Hosts, F. G. Cawston, 832; America, The Early Metal Ages in, H. Ballour, 141; Australia, Ecology of, 305; Iron Ore in, R. L. Jack, 129; Plant Habits and Habitats in the Arid Portions of, W. A. Cannon, 365; -Eastern Agricultural College, Wye, R. M. Wilson appointed Principal of the, 134; Kensington, Science and Education at, T. Ll. Humberstone, 79; Wales and Monmouthshire, University College of, Dr. A. J. S. Pippard appointed Professor of Engineering at, 562; -west of England, University College of the, First Meeting of the Court of Governors of the, 684
- Southern Sudan, Secret Societies in the, 21
- Space: Division of, by Congruent Triangles and Tetrahedra, D. M. Y. Sommerville, 862; -time Geodesics, Prof. H. T. H. Piaggio, 699; Dr. A. A. Robb, 809
- Spain and Ireland, The Prehistoric Relations between, Dr. W. E. Scott, 228
- Spark Spectra in Water, L. and E. Bloch, 27
- Specialisation in Universities, 65
- Spectra: A Treatise on the Analysis of, based on an Essay to which the Adams Prize was awarded in 1921, Prof. W. M. Hicks, 690; on the Quantum-orbit Theory, Prof. W. M. Hicks, 292; Line, Report on Series in (The Physical Society of London), Prof. A. Fowler, 690; Selection in, An Exception to the Principle of, S. Datta, 39; The Study of, 600
- Spectrometer: A Direct-reading, Bellingham and Stanley, Ltd., 129; A Chemical, Adam Hilger, Ltd., 191
- Spectro-polarimeter, A New, Bellingham and Stanley, Ltd., 526
- Spectroscopic: Parallaxes for Type A, Adams and Joy; J. Evershed, 584; Parallaxes of B Stars, D. L. Edwards, 886; Studies of Stellar Velocities, Dr. W. J. S. Lockyer, 95
- Spectrum: Lines of Neutral Helium derived Theoretically, Some, Dr. L. Silberstein, 247, 248; Prof. W. M. Hicks, 309; Unsymmetrical, Errors arising in the Measurement of, Prof. T. R. Merton and D. N. Harrison, 62; of Carbon Monoxide, The Mass of the Particles, which give the, M. Dumieux, 268; of the Night Sky, Lord Rayleigh, 769
- Speed Reckoner, Land and Sea, Capt. W. N. McClean, 308
- Sphere: -gap Voltmeter, The, Dr. E. A. Owen, 615; Motion of a, in a Rotating Liquid, G. I. Taylor, 62
- Spirula, Live Specimens of, Dr. Johs. Schmidt, 788
- Spitsbergen: and its Wild Life, 597; Surveys in, R. A. Frazer, 786
- "Standards, Immured," The, in the House of Commons, 230
- St. Andrews University: Conferment of the Honorary Degree of LL.D. upon the Prince of Wales, 498; Dr. H. S. Allen appointed Professor of Natural Philosophy in, 653; Rudyard Kipling elected Rector of, 684
- Stannic Acids, Magnetic Analysis of the, P. Pascal, 863
- Star: A Bright New, 785; A very Massive, 53; Dr. J. S. Plaskett, 364

- Stars: Absolute Magnitudes of, Dr. H. D. Curtis, 395; Double, Observations of, 1907-1910, Prof. G. C. Comstock, 7; of the N type, Observations of, C. Nordmann and Le Morvan, 167; The Atmosphere of the, H. Deslandres and V. Bursou, 268; The Radial Velocities of, 594; Dr. J. S. Plaskett and others, 95; the Spectra of, The Rôle of Anomalous Dispersion in, M. Maggini, 723; Variable, 645; near M. 53, Dr. Baade, 364; Visual Binary, The Masses of, J. A. Miller and J. H. Pitman, 555
- State throw away the Keys? Shall the, 782
- Statesman's Year-Book, The, 1922, Edited by Sir John Scott Keltic and Dr. M. Epstein, 75
- Static Deflection, Logarithmic Decrement and First Semi-period of the Vacuum Gravitation Needle, Prof. C. Barus, 687
- Statics: Dynamics, and Hydrodynamics, Dr. S. Brodetsky, 243; Elementary, of Two and Three Dimensions, Prof. R. J. A. Barnard, 243
- Stearoptene, Preliminary Note on a New (probably a Phenol Ether) occurring in some Essential Oils of the Myrtaceæ, A. R. Penfold and F. R. Morrison, 300
- Steel: Bars, Mild, hardened by Extension, The Possibilities of the Commercial use of, M. Seigle, 623; The Principal Characteristics of Mild, previously broken by Traction, M. Seigle, 591; Oxygen in, The Estimation of, G. Chaudron and L. Blanc, 795; The Case-hardening of, an Illustrated Exposition of the Changes in Structure and Properties induced in Steels by Cementation and Allied Processes, H. Brearley, Second edition, 537; Thermal Treatment, J. W. Urquhart, 837
- Steels: Engineering, Dr. L. Aitchison, 537; the Ar I Change in, The Effect of Deformation on, J. H. Whiteley, 682; The Flow of, at a Low Red Heat, J. H. Dickenson, 776; under Stress, Electrical Resistivity of, Sin-iti Fukuta, 430
- Stellar: Distances, The Determination of, Dr. W. J. S. Lockyer, 219; Radiometers and Measurements of the Energy Distribution in the Spectra of 16 Stars, Tests of, Dr. W. W. Coblentz, 367; Radiation in the Infra-red, 367; Temperatures and Planetary Radiation, Dr. W. W. Coblentz, 886; Velocities, Spectroscopic Studies of, Dr. W. J. S. Lockyer, 95
- "Stereo-agraph," A New, M. Poivilliers, 723
- Sterility: Interspecific, Dr. W. Bateson, 76; Prof. R. R. Gates, 179, 447; Dr. J. W. H. Harrison, 312; Prof. J. P. Lotsy, 843; Species-crosses in, J. B. S. Haldane, 748
- Stirling, James, A Sketch of his Life and Works, along with his Scientific Correspondence, C. Tweedie, 111
- Stone on Buildings, The Preservation from Decay of, Prof. A. P. Laurie, 746
- Stonehenge: The Age of, E. H. Stone, 201; The Date of, Rear-Admiral B. T. Somerville, 429
- Storm Tracks, Anomalous, E. H. Bowie, 429
- Strasbourg University, Conferment of an Honorary Doctorate upon Sir James Frazer, 754
- Strathmore Meteorite, Structure and Composition of the, W. E. P. McLintock and F. R. Ennos, 99
- Stratosphere, The Geostrophic Approximation in the, L. F. Richardson, A. Wagner, and R. Dietzius, 27
- Street Lighting, H. T. Harrison and others, 888
- Submarine: A New Method for detecting the Presence of, A. P. Sacerdote and P. Lambert, 299; Cable Telegraphy, Pioneer Work in, Sir Charles Bright, 195
- Süd-Bayern, Dr. R. H. Francé, 246
- Sugar: Beet, Condensed Description of the Manufacture of, Dr. F. Murke, 4; Cane, A Text-book on the Agriculture of the Sugar Cane: The Manufacture of Cane Sugar, and the Analysis of Sugar-house Products, N. Deerr. Second edition, 4; The Manufacture of, L. J. Jones and F. I. Scard. Second edition, 4; from Beet Molasses, Recovery of, C. Deguide and P. Baud, 22; Technology, Prof. A. R. Ling, 4
- Sulphate on Limestone in Urban Centres, The Spontaneous Formation of, A. Kling and D. Florentin, 831
- Sulphur: Dioxide in Cattle Foods after Fumigation, Presence of, H. A. Peacock, 804; Absorption Spectrum of, for the X-rays, A. Lindh, 200
- Sulphuric Acid Test for Fish Liver Oils, N. Evers and H. J. Foster, 894
- Summer Time, End of, 493
- Sun, Observations of the, made at the Lyons Observatory, J. Guillaume, 235
- Sunflower, Embryo of the, Comparative Resistance to Heat of the Growing Points of the, E. Gain, 64
- Sun's Activity, The, 1800-1920, Dr. W. J. S. Lockyer, 465
- Sunspot: in High Latitude, 428; Periodicity, The, Prof. T. J. J. See, 525
- Sunspots, Invisible, Dr. G. E. Hale, 395
- Superheated Steam, Effect of, on Non-ferrous Metals used in Locomotives, Sir Henry Fowler, 467
- Surface Tension and Cell-division, H. G. Cannon, 181
- Surveying Instruments, T. Cooke and Sons', List of, 324
- Sussex Iron Industry, Early History of the, R. Jenkins, 893
- Swanley Horticultural College, Dr. Katie Barratt appointed Principal of, 828
- Swastika: Symbol, Origin of the, H. K. Deb, 228; Gammadion, Fyllot, H. K. Deb, 365
- Sweden, A Book about, 631
- Switching: and Switchgear, H. E. Poole, 805; Equipment for Power Control, S. O. Hayes, 373
- Switzerland, The Lake Dwellings of, Recent Investigations of, Prof. E. Pittard, 12
- Sydney University Eclipse Expedition, The Photographic Work of the, E. H. Booth, 896
- Sylvinite and its Components, The Comparative Action of, on the First Development of Plants, P. Lesage, 831
- Symbiosis, Studies in, Part II., J. McLuckie, 500
- Symbolism as a Basis for Metaphysics, Bishop Temple, 231
- Syme, David, Research Prize of Melbourne University, H. G. Smith awarded the, 259
- Syntony, Colour Vision and, Prof. E. H. Barton, 357
- T Coronæ (1866), Nova, K. Lundmark, 493
- Tanning, Practical, Dr. A. Rogers. Partly based on the third edition of "Practical Tanning," by L. A. Flemming, 840
- Tar Distillation, W. A. Walmsley, 130
- Tartaric Acid, The Neutralisation of, by Potash in presence of the Chlorides of the Alkaline Earths, L. J. Simon and L. Zivy, 655
- Technical: Education, J. Paley Yorke, 24; Lord Burnham, 25; Institutions and the Board of Education, 657
- Technische Träume, H. Günther (W. de Haas), 663
- Telegraphie und Telephonie, Die drahtlose, Dr. P. Lertes, 273
- Telephony: Long Distance, F. Gill, 718; Proposed Conference on, 745
- Telescope, The, Dr. L. Bell; Dr. J. Weir French, 627
- Telescopes versus Field Glasses, Dr. A. Sonnefeld, 292
- Tellurium, Amorphous, The Crystallisation of, A. Damienis, 63
- Temperature: in the Upper Air, Circumstances determining the Distribution of, under Conditions of High and Low Barometric Pressure, A. H. R. Goldie, 795; Rise in, of Living Plant Tissue when infected by Parasitic Fungus, Dr. I. B. Pole Evans and Mary Pole Evans, 480
- Temperatures: Recent Remarkable, R. C. Mossman, 126; Surface, in the North Sea and in German Lakes, 229
- Terrestrial Magnetism, A Rapid Method of determining the Elements of, A. Perot, 795
- Tetanic and Diphtheric Toxins administered by the Mouth, The Action of the, J. Dumas, D. Combiesco, and J. Baltiano, 724
- Tetramitus, Preliminary Note on, Martha Bunting, 687
- Textile: Design and Colour: Elementary Weaves and Figured Fabrics, W. Watson. Second edition, with an Appendix in Standard Yarns, Weaves, and Fabrics, 74; Fibres, A New, A. S. Moore, 679; Institute, Journal of the, 819; Technology, 272
- Textiles, Prof. A. F. Barker and others. Revised edition, 272
- Thermal: Basis of Gas Supply, The, Prof. J. W. Cobb, 671; Ionisation of Gaseous Elements at High Temperatures, A. A. Noyes and H. A. Wilson, 687
- Thermodynamics, The Presentation of, 207
- Thermodynamik, Vorlesungen über, Prof. Max Planck. Sechste Auflage, 207

- Thermographs and Hydrographs, Pastorelli and Rapkin's List of, 52
- Thermostats with Multiple Jackets, A. Tian, 27
- Thionic Epos, Rhapsodies culled from the, Prof. H. E. Armstrong, 130
- Thionyl Chloride, The Action of, on the  $\alpha$ -acid Alcohols, E. E. Blaise and Mlle. Montagne, 64
- Thomas Slag, The Accessory Elements in, A. Demolon, 168
- Thorium-X, the Oxidising Properties of, Some Microbiological Consequences of, P. Lemay and L. Jaloustre, 863
- Thortveitite from Madagascar, The Composition and Chemical Characters of, C. Boulanger and G. Urbain, 27
- Thought-coin, B. Kennedy, 147
- Three Bodies, The Problem of, 290
- Thunderstorms: Formation of, E. V. Newnham, 129; Local or Heat, Prof. C. F. Brooks, 615
- Tibet: and Nepal, The Border Land of, 139; Chinese, Expedition to, Prof. J. W. Gregory and C. J. Gregory, 719; Southern, Discoveries in Former Times compared with my own Researches in 1906-1908, Dr. Sven Hedin. II. A List of Flowering Plants from Inner Asia, collected by Dr. Sven Hedin, determined by Various Authors, and compiled by Prof. C. H. Ostenfeld and Dr. O. Paulsen, 170
- Tidal Institute of the University of Liverpool, Third Annual Report of the, 323
- Timber: Home-grown, Exhibition demonstrating some of the Minor Uses of, 744; The Drying of, R. T. Patton, 332
- Timbers: Indian, A Manual of: an Account of the Growth, Distribution, and Uses of the Trees and Shrubs of India and Ceylon, with Descriptions of their Wood-structure, J. S. Gamble. Reprint, 276; Useful, A Guide to the Identification of our more: being a Manual for the Use of Students of Forestry, H. Stone, 276
- Tin: and Tungsten Ores, Treatment of, 647; Resources of the British Empire, The, N. M. Penzer, 5
- Tinctorial Chemistry and Histology, Dr. M. Nierenstein, 33
- Titration of Strong Liquids by Dilution and Use with Aliquot Parts, A Sliding Scale for the Convenient, C. H. D. Clark, 894
- Tobacco Plants, Relation of Transpiration to Dry Weight in, N. B. Mendiola, 679
- Toronto University, Prof. A. T. Delury appointed Dean of the Faculty of Arts of, 684
- Tournage du bois, Manuel de, H. Gaschet, 510
- Town Theory and Practice, W. R. Lethaby and others, 307
- Trackways, Moats, Mounds, Camps, and Sites, Early British, A. Watkins, 176
- Trails leading to Springs of Water, Indian Method of marking, 523
- Transformers and Alternating Current Machines, The Testing of, Dr. C. F. Smith, 805
- Transparency of Liquids and Colour of the Sea, Prof. C. V. Raman, 280
- Transparent Liquids, The Polarisation and Intensity of Light diffused by, J. Cabannes, 795
- Transport by Different Agencies, The Relative Cost of, 744
- Tropical: Africa, Wild Bush Tribes of, G. C. Claridge, 340; Cyclones in Southern Hemisphere, Dr. S. S. Vishner, 647; Medicine, Discoveries in, Sir Ronald Ross, 38; Lt.-Col. A. Alcock, 114
- Tungsten, The Decomposition of, Drs. Wendt and Irion, 529
- Turbo-compressor for Aviation Motors, General Theory of the, Prof. A. Rateau, 63
- Turbulence: as exhibited by Anemometer Records, Smoke and Cloud Formation, A. E. M. Geddes and C. A. Clarke, 235; on a Large Scale, A Defiant, 405
- "Turtle-Oreodon Layer," The, in S. Dakota, Prof. W. J. Sinclair, 128
- Typhoon, A Violent, at Swatow, 260
- Ulster, edited by G. Fletcher, 339
- Ultraviolet Rays, Absorption of the, by Naphthalene, V. Henri and P. Steiner, 468
- Unconscious, Is the, a Conception of Value in Psychology? G. C. Field, Dr. F. Aveling, and Prof. J. Laird, 231
- Underground Workrooms, 191
- Uniformity and Contingency, Prof. A. N. Whitehead, 756
- United States: Universities and Scientific Life in the, Prof. M. Caullery. Translated by J. H. Woods and E. Russell, 72; State Universities and State Colleges, Statistics for 1920-21 of, 98; Educational Legislation in, in 1919-20, 267; Secondary Education in the, 297; Chemical Foundation, The, 334; Administration of Schools in the Smaller Cities, 562
- Universal Problems, H. Jamyn Brooks, 804
- Universities: an International Congress of all, A Project for, 330; of Great Britain and Ireland, Proceedings of the Annual Conference, 860; Parliamentary Aid to, 1; Research in, The Development of, Principal Irvine, 131; Specialisation in, 65
- University: College: London, Bequest to, by Sir William S. Meyer, 754; of North Wales, Bangor, Dr. E. Greenly appointed Special Lecturer in Geology at the, 108; Education in London, 240; Representation in Parliament, 625; Teachers, Association of, Extension of Work of the, 793
- Upper: Air Research in the United States, W. R. Gregg, 397; Cloud Drift, Observations of, as an Aid to Research and to Weather Forecasting, C. K. M. Douglas, 235
- Uranus, The Brightness and Rotation of, C. Wirtz, 747
- Uranyl Nitrate, The Precipitation of, by Soda, P. Jolibois and R. Bossuet, 136
- Urease and Urea in Fungi, A. Goris and P. Costy, 623
- Ute Indians, The Music of the, Miss Frances Densmore, 646
- Vaccination: before Operation, P. and L. Bazy, 167; Smallpox and, 725
- Vaccine, An Unpublished Method of preparing, R. Zivy, 687
- Values, A Coincidence in, L. M. Stewart, 279
- Vanadium in Fused Salts, Quantitative Researches on the Line Spectrum of, A. de Gramont, 805
- Vapour Pressure of some Copper-zinc Alloys in the Solid State, L. Guillet and M. Bailly, 863
- Végétale, Physiologie, Précis de, Prof. L. Maquenne, 177
- Vegetation: in the North and East of France, The Limits of, A. Guillaume, 686; of High Asia, The, 170
- Venoms, Animal, 691
- Ventilation and Atmosphere in Factories and Workshops, Prof. L. Hill, 644
- Venus and Jupiter, Conjunction of, 260
- Verse, Physical Nature of, Prof. E. W. Scripture, 494
- Vertebrate Anatomy, Comparative, A Laboratory Manual for, L. H. Hyman, 571
- Vertébrés, The Development of, 275
- Vertébrés, Traité d'embryologie des, Prof. A. Brachet, 275
- Vesuvius, Activity of, 87
- Veterinary Anatomy in England in the 16th, 17th, and 18th Centuries, Maj.-General Sir Frederick Smith, 296
- Vibration Galvanometers with Asymmetric Moving Systems, R. L. Jones, 829
- Victoria: Contributions from the National Herbarium of, No. 2, S. R. Tovey and P. F. Morris, 332; The Dominion Astrophysical Observatory, 189; the Flora of, An Addition to, H. B. Williamson, 168; The Giant Trees of, J. D. Peirce, 830
- Victorian: Age, The: the Rede Lecture for 1922, Dr. W. R. Inge, 104; Fossils, New or Little-known, in the National Museum, Part xxvi., F. Chapman, 165
- Village: Communities, 371; The English: the Origin and Decay of its Community. An Anthropological Interpretation, H. Peake, 371
- Viper, Common, Capture of a Large Specimen of the, in Epping Forest, W. K. Ford, 461
- Virus Diseases: in Animals and Man, J. A. Arkwright, 622; in Plants, E. J. Butler, 622
- Visibility as a Sign of Coming Rain, W. H. Pick, 713
- Vision, A New Theory of, Dr. F. Schanz, 557
- Visual Images, Recurrent, Self Light, Fatigue, Inhibition, and, Prof. W. Peddie, 100
- Vitamin: A, Sources of, H. L. Jameson and others, 429; Problems, Prof. A. Harden, 14

- Vitamins: Prof. H. C. Sherman and S. L. Smith, 6; Prof. J. C. Drummond and others, 652; and the Choice of Food, Violet G. Plimmer and Prof. R. H. A. Plimmer, 336; Voleting for, Drummond and Watson, 557
- Voice Beautiful in Speech and Song, The: a Consideration of the Capabilities of the Vocal Cords and their Work in the Art of Tone Production, E. G. White. Third edition, 871
- Volcanic: Activity in Nigeria, A. A. Reading, 97; H. S. Cameron, 497; Shower in the N. Atlantic, Prof. G. A. J. Cole, 635
- Vulcanising Rubber in Solution, F. Boiry, 235
- Wake Forest College School of Medicine, Gift to, by J. A. Bostwick, 166
- Walking, Level and Grade, Gaseous Exchange and Physiological Requirements for, H. M. Smith, 728
- Walnut Trees, The Withering of Young, in 1922, M. Gard, 686
- War: History of the Great, based on Official Documents, Medical Services: Diseases of the War, vol. i., Edited by Maj.-General Sir W. G. MacPherson and others, 729; Museum, Fifth Annual Report of the Imperial, 523; Office Research Department, Dr. R. C. Farmer appointed Deputy Director of Explosives Research at the, 460
- Wasp, An Ancient, Prof. T. D. A. Cockerell, 313
- Wasserstoffionen-Konzentration, Die, ihre Bedeutung für die Biologie und die Methoden ihrer Messung, Prof. L. Michaelis, Zweite Auflage, Teil I., 305
- Watches and Chronometers, A New Balance for Compensating the Temperature Error of, P. Ditisheim, 830
- Water: -power in the British Empire. The Reports of the Water-power Committee of the Conjoint Board of Scientific Societies, 767; Snails and Liver Flukes, Dr. Monica Taylor, 701; R. Hedger Wallace, 845; -supply, A Little Book on, Dr. W. Garnett, 275; in Central Australia, O. H. T. Rishbeth, 822; of Cambridgeshire, Huntingdonshire, and Rutland from the Underground Sources, The, W. Whitaker, 7; Underground, Prof. G. A. J. Cole, 242; Vapour, Air, and Hydrogen in the Extreme Ultra-violet, New Spectra of, J. J. Hopfield, 732
- Waterpouts: Dr. G. D. Hale Carpenter; Dr. D. Brunt, 414; Dr. W. J. Fisher, 669; and Centrifugal Force, E. R. Welsh, 644
- Weather: at Blue Hill, 91; Charts of the Northern Hemisphere, Daily, 853; Cold, in October, 612; Cycles in Relation to Agriculture and Industrial Fluctuations, Sir William Beveridge and others, 889; Map, The, an Introduction to Modern Meteorology, Sir Napier Shaw. Fifth issue (reprint of fourth), 768; of the Past Summer, The, 362; Prediction by Numerical Process; Forms whereon to write the Numerical Calculations described in "Weather Prediction by Numerical Process," L. F. Richardson, 762; The Proportion of Successes in, J. Mascart, 655
- Wegener's: Displacement Theory, P. Lake, 77; E. R. Roe-Thompson, 214; Disruption Hypothesis, Maps illustrating the Zoological Aspects of, K. H. Barnard, 332; Drifting Continents, Prof. G. A. J. Cole, 798
- Weights and Measures for India, New, C. A. Silberrad, 325, 735; H. Richards, 734
- West: Africa, French, The Oil Palm in, 164; Indian Agricultural College, 134, 684; Prof. J. B. Farmer, 775; Hurricanes, E. H. Bowie, 614; Indies, Fungus-hunting in the, Miss E. M. Wakefield, 563; Weather in the, 823
- Western Australia, Economic Minerals of, 746
- Whaling Industry, The Present Position of the, Sir Sidney F. Harmer, 827
- White Settlement, Distribution of Future, Dr. Griffith Taylor, 526
- Whitethroat's Fanfare, The Lesser, Prof. W. Garstang, 319
- Whitgift Hospital, Croydon, Threatened Destruction of, 782
- Whitworth Scholarships, The, 620
- Wild Birds Protection Acts, Dr. J. Ritchie appointed an Additional Member of the Committee on the, 461
- Wind: Flight, Motorless or, Dr. S. Brodetsky, 483; -speed from Sea and Land, N. K. Johnson and S. N. Sen, 462; Velocity and Diurnal Range of Temperature, 749
- Winkle, The Freshwater, A. E. Hodge, 380
- Winter Thunderstorms, Capt. C. J. P. Cave, 877
- Winters, Severe, The Periodic Return of, E. Roger, 863
- Wireless: Equipment, Safety Devices in, 22; Pocket Book, Marine, for the Practical Operator and Student, W. H. Marchant, 273; Receiving Set, Metropolitan Vickers Co., Ltd., 324; Telegraph, Short-wave Directional, C. S. Franklin, 220; Telegraphy: Continuous Wave, A Non-Mathematical Introduction to the Subject of Wireless Telegraphy from the Engineer's Point of View, B. E. G. Mittell, 273; The Transmission of Handwriting and Drawings by, E. Behn, 136; Telephony, A. P. M. Fleming, 852; Receiving Sets, C. F. Edwell, Ltd., 127; *Weather Manual, The*, 461
- Wisconsin University, Prof. A. Sommefeld to lecture at, 368
- Witwatersrand University, Dr. R. A. Dart appointed Professor of Anatomy in, 720
- Wolf's Comet, Perturbations of, Prof. Kamensky, 525
- Wood, A Text-book of, H. Stone, 73
- World: About us, The, A Study in Geographical Environment, O. J. R. Howarth, 376; First Circumnavigation of the, The Fourth Centenary of the, 426; -story of 3,000,000,000 (?) Years, The, J. Reeves, 443
- Worlds, The Origin of, Dr. A. C. D. Crommelin, 660
- Worship? A New, Prof. H. E. Armstrong, 700
- Wren, Sir Christopher, Preparations for the Celebration of the Bi-Centenary of the Death of, 226
- X-radiation, Variation of the Intensity of Reflected, with the Temperature of the Crystal, I. Backhurst, 654
- X-ray: Crystal Analysis, Ten Years of, Dr. A. E. H. Tutton, 47; Department at Manchester, New, 753; Electrons, le Duc de Broglie, Prof. R. Whiddington, Prof. A. O. Rankine, 681; Reflection from Powdered Crystals, The Intensity of, Prof. A. H. Compton and N. L. Freeman, 38; Prof. W. L. Bragg and R. W. James, 148
- X-rays, The Spectral System of the, L. de Broglie and A. Dauvillier, 686; Ultra X-rays, and Corpuscular Rays, The Emission of, by the Celestial Bodies, Dr. H. Deslandres, 622
- Year, The Changing, A. Collett, 410
- Yorkshire Philosophical Society, Centenary of the, 393, 459
- Zinc, Isotopes of, Separation of the, A. C. Egerton, 773
- Zoological: Nomenclature, International Commission on, The, for the, Dr. D. S. Jordan, 523; Society, The, E. G. Boulenger, 314; Gardens, Scheme for an Aquarium at the, 17; Station at Rovigno, Istria, taken over by the Italian Royal Committee for Scientific Marine Investigations, 19
- Zoologischen Anzeiger, Register zum, begründet von J. V. Carus. Herausgegeben von Prof. E. Korschelt. Band xxxvi.-xl., und Bibliographia Zoologica, vol. xviii.-xxii., 245
- Zoology, A Text-book of, the late Prof. T. J. Parker and Prof. W. A. Haswell. In two volumes. Third edition, 765





# NATURE

A WEEKLY ILLUSTRATED JOURNAL OF SCIENCE.

*"To the solid ground  
Of Nature trusts the mind which builds for aye."*—WORDSWORTH.

No. 2748, VOL. 110]

SATURDAY, JULY 1, 1922

[PRICE ONE SHILLING

Registered as a Newspaper at the General Post Office.)

[All Rights Reserved.]

## NEWTON'S (New Model) "DEMONSTRATOR'S" LANTERN

For all classes of  
Projection Work.

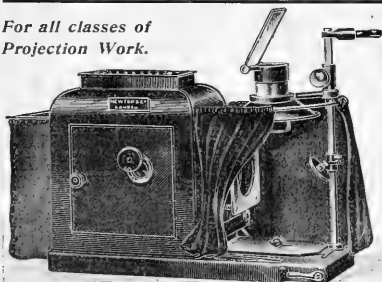

Full particulars sent on application.

NEWTON & Co., 72 Wigmore St., London, W.1.  
(Specialists in Optical Projection Apparatus.)

DO YOU KNOW  
THAT  
VITREOSIL LABORATORY WARE

IS  
Incomparably Superior  
to any other similar Material?

IT IS  
Constant in Weight, Reliable,  
and Reasonable in Price.

Write for Pocket Edition of  
Price List.

HEAT  
PROOF



ACID  
PROOF

SOLE MANUFACTURERS

THE THERMAL SYNDICATE, LTD.,

VITREOSIL WORKS—WALLSEND-ON-TYNE.

LONDON DEPOT—28 VICTORIA ST., S.W.1.

ALSO AT PARIS AND NEW YORK.

BAIRD & TATLOCK (LONDON) LTD.

SCIENTIFIC INSTRUMENT MANUFACTURERS  
and LABORATORY FURNISHERS.

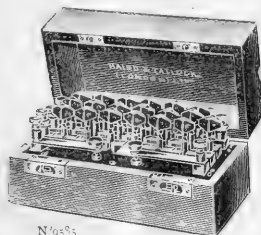

N° 654  
RESISTANCE BOX

Physical  
Apparatus  
for  
Schools  
and  
Colleges

14-15 CROSS STREET, HATTON GARDEN, LONDON, E.C.1.

## HOLIDAY BINOCULARS

We have over 40 different Prism  
models, and many second-hand pat-  
terns in stock. Ask for price list  
"B.N.," or for a selection on approval.

NEGRETTI & ZAMBRA  
38, HOLBORN VIADUCT, E.C.1.  
LONDON.

## THE INSTITUTE OF PHYSICS.

### LECTURES ON "PHYSICS IN INDUSTRY."

The SECOND LECTURE of this series, entitled "The Physicist in Engineering Practice with special Reference to Applications of Thermodynamics," will be delivered by Sir J. ALFRED EWING, K.C.B., F.R.S., on Tuesday, July 4, 1922, at 5.30 P.M., at the Institution of Electrical Engineers, Victoria Embankment, W.C.2. Sir CHARLES PARSONS, K.C.B., F.R.S., will preside.

to Essex Street, W.C.2.

F. S. SPIERS, Secretary.

## FINSBURY TECHNICAL COLLEGE.

LEONARD STREET, CITY ROAD, E.C.2.

Dean for the Session, 1921-22:

Professor W. H. ECCLES, D.Sc., F.R.S.

The College provides practical scientific training for students who desire to become Civil, Mechanical, or Electrical Engineers, or Chemists.

Candidates are required to pass an Entrance Examination in Mathematics and English, but the Matriculation Certificate of any British University, and certain other qualifications, are accepted in lieu of it. The next Entrance Examination will be held on Tuesday, September 19. Applications for admission should be forwarded to the College on forms to be obtained from the REGISTRAR. The programme of the College is under revision and will be issued shortly.

## SCHOOL OF GARDENING AND NATURE STUDY.

CLAPHAM, near WORTHING.

Principal: { Miss C. CRACKNELL, N.D. Hort., late of Swanley Horticultural College,  
Miss F. COLLINS.

PRACTICAL and THEORETICAL TRAINING in GARDENING: Fruit, Vegetable, and Flower Growing; Glasshouse and Frame Work. Course of two years; Poultry; Dairy Work; Bees. Preparation for R.H.S. Examinations.

## ROYAL HOLLOWAY COLLEGE. (UNIVERSITY OF LONDON.)

The MICHAELMAS TERM commences on Thursday, October 5, 1922. The College prepares Women Students for the London Degrees in Science and Arts. Nine Entrance Scholarships, from £50 to £60 a year, and several Bursaries of not more than £35, tenable for three years, will be offered for competition in April 1923.

For further particulars apply to the SECRETARY, Royal Holloway College, Englefield Green, Surrey.

## BEE RESEARCH INSTITUTE.

ROTHAMSTED EXPERIMENTAL STATION.

The Committee of the above Institute will shortly appoint a BIOLOGIST as ASSISTANT attached to the ENTOMOLOGICAL DEPARTMENT to carry out research work on Apiculture. Previous experience with bees is not essential, but the successful candidate will be required to undergo the necessary training during the first year of his appointment. Apply before July 6, stating University qualifications, to the SECRETARY, Rothamsted Experimental Station, Harpenden, Herts.

## RESEARCH PRIZE OF \$1000.

The ELLEN RICHARDS RESEARCH PRIZE is offered for award in the year 1923. Theses by women based on independent laboratory research are eligible for competition and must reach the Committee before February 25, 1923. For circulars of information and application blank, apply to Dr. LILIAN WELSH, Goucher College, Baltimore, Maryland.

## UNIVERSITY COLLEGE OF SOUTH WALES AND MONMOUTHSHIRE.

COLEG PRIFATHROFAOL DEHEUDIE CYMRU A MYNWY.

The Council of the College invites applications for the following posts, viz.:

1. PROFESSOR OF ENGINEERING. Salary, £1000 per annum. (20 Copies of Application with Testimonials to be forwarded not later than AUGUST 31, 1922.)
2. ASSISTANT LECTURER and DEMONSTRATOR in PHYSICS. Salary, £300 per annum. (3 Copies of Application with Testimonials to be forwarded not later than July 6, 1922.)

Further particulars regarding the above posts may be obtained from the undersigned.

D. J. A. BROWN, Registrar.

University College, Cardiff,  
June 13, 1922.

## BIRKBECK COLLEGE.

(UNIVERSITY OF LONDON.)

EVENING COURSES for the Degrees of the University of London in the Faculty of Science and the Geography Diploma.

Facilities are also provided during both day and evening for Post-Graduate and Research Work.

Prospectus Free.

G. F. TROUP HORNE,

Secretary.

Birkbeck College, E.C.4.

## BATTERSEA POLYTECHNIC, LONDON, S.W.11.

Principal—ROBERT H. PICKARD, D.Sc., F.R.S.

## DOMESTIC SCIENCE TRAINING COLLEGE.

Head of Training College—Miss MARY E. MARSDEN.

Recognised Courses of training for Teachers of Cookery, Laundrywork, Housewifery. Third year courses of training in Science applied to Housecraft, Advanced Cookery with cognate Chemistry, Needlework, Dress-making, and Ladies' Tailoring. Training for School Matrons and Housekeepers.

## DEPARTMENT OF HYGIENE AND PUBLIC HEALTH.

Head of Department—Miss HILDA BIDELEUX.

Recognised Training Courses (one or two years) for Health Visitors, Sanitary Inspectors, Infant Welfare Workers, and Teachers of Hygiene. Preparatory Courses are also arranged.

For particulars of curricula, fees, scholarships, maintenance grants, and Hostels, apply to the PRINCIPAL.

## APPOINTMENTS BOARD

OF THE

## IMPERIAL COLLEGE OF SCIENCE AND TECHNOLOGY,

SOUTH KENSINGTON, S.W.7.

EMPLOYERS requiring men who have received a thorough training in Science and Technology, and who are Diplomates or Associates of the Imperial College, or of one of its three constituent Colleges, are asked to make use of the services of the Board. No fees.

The Imperial College includes The Royal College of Science, The Royal School of Mines, and The City and Guilds (Engineering) College. The Associates of the Colleges receive thorough training in Science and Technology, including Aeronautics, Applied Optics and Optical Engineering, Biology, Chemical Technology, Chemistry (all branches), Engineering (all branches, including Metallurgy, Mining, Mining Geology and Oil Technology), Geology, Mathematics and Mechanics, and Physics.

## LANCASHIRE COUNTY COUNCIL EDUCATION COMMITTEE.

### ASSISTANT LECTURER IN AGRICULTURE.

Applications are invited for the post of ASSISTANT LECTURER IN AGRICULTURE, salary £350 per annum.

Candidates must possess either a University Degree or Diploma in Agriculture, a thorough knowledge of practical agriculture, and, if possible, experience in lecturing.

Further particulars and forms of application may be obtained from the undersigned. Applications, together with copies of three testimonials of recent date, must reach this office on or before July 17.

County Offices, Preston.

G. H. GATER, M.A.,  
Director of Education.

YOUTH, aged 19, Intermediate B.Sc., desires situation in Chemical Laboratory. London district preferred. Box No. 1/263, c/o NATURE Office.



# NATURE

A WEEKLY ILLUSTRATED JOURNAL OF SCIENCE.

*"To the solid ground  
Of Nature trusts the mind which builds for aye."*—WORDSWORTH.

SATURDAY, JULY 1, 1922.

## CONTENTS.

	PAGE
Parliamentary Aid to Universities . . . . .	1
The New Astronomy. By R. A. G. . . . .	2
Index Animalium . . . . .	3
Sugar Technology. By Prof. Arthur R. Ling . . . . .	4
Geology and Tin Resources of the British Empire. By C. G. C. . . . .	5
Our Bookshelf . . . . .	6
Letters to the Editor :—	
The Stature of the Scottish People.—Sir Arthur Keith, F.R.S. . . . .	8
Advanced Mathematical Study and Research at Cambridge.—Prof. H. S. Carslaw . . . . .	8
Condition of Electrolytes in the Blood.—Benjamin S. Neuhausen . . . . .	9
The Dimensions of Area.—Dr. Norman R. Campbell . . . . .	9
The Resonance Theory of Hearing.—Dr. H. Hartridge . . . . .	9
An Experimental Towing-tank used by Benjamin Franklin.—Paul C. Whitney . . . . .	10
An Experimental Confirmation of the Kinetic and Molecular Theories of Magnetism.—Dr. J. R. Ashworth . . . . .	10
Molecular Helotropy in Liquids.—Prof. C. V. Raman . . . . .	11
Recent Investigations of the Lake Dwellings of Switzerland. ( <i>Illustrated</i> ). By Prof. Eugène Pittard . . . . .	12
Vitamin Problems. By Prof. A. Harden, F.R.S. . . . .	14
Obituary :—	
Prof. W. Gowland, F.R.S. By H. C. H. C. . . . .	16
E. W. L. Holt. By E. J. A. . . . .	17
Current Topics and Events . . . . .	17
Our Astronomical Column . . . . .	20
Research Items . . . . .	21
Quantum Mechanism in the Atom . . . . .	23
The Second Royal Society Conversazione . . . . .	23
Psychical Monism . . . . .	24
Technical Education . . . . .	24
University and Educational Intelligence . . . . .	26
Societies and Academies . . . . .	25
Official Publications Received . . . . .	28
Diary of Societies . . . . .	28

## Parliamentary Aid to Universities.

THERE is need for a clear definition of the present position in regard to Government grants for university education in Great Britain. Statements of a seemingly contradictory nature have been made, and it is not surprising that misunderstandings have arisen. On one hand we have the fact that the parliamentary votes for university education are reduced from 1,500,000*l.* to 1,169,000*l.*, while on the other we are told that the grants to the universities this year will be no less than last and that the annual grants are to be maintained at their present scale. The real facts of the situation have become obscured by certain complexities, arising mainly from the difference between the Government financial year and the academic year, and from the exclusion this year of the Irish grants.

The first announcement of the Treasury's decision to reduce Government aid to university education was a simple one, to the effect that Parliament would be asked to vote for this purpose only 1,200,000*l.* instead of the million and a half voted last year. But the larger amount of last year included provision for Irish universities, amounting altogether to 111,000*l.* (not counting an emergency grant to Trinity College, Dublin), while this year the sum reserved in the estimates—namely, 1,169,000*l.*—makes no allowance for the Irish universities. The amount available for university education in Great Britain therefore falls, if the estimates are approved by parliament, from 1,389,000*l.* to 1,169,000*l.*—that is, by 220,000*l.*—the sum mentioned by the president of the Board of Education in his recent speech at Bristol.

The net reduction in the grant is happily less than was at first anticipated. But, even so, it is difficult at first sight to reconcile a loss of over 220,000*l.* with Mr. Fisher's remark to the effect that there would be

no real reduction of the amount of parliamentary money placed at the disposal of the universities this year. The explanation is to be found in the fact that the grants to the universities are made in respect of the academic year ending on July 31, while the parliamentary votes are for the year ending on March 31. Thus the grants for this present academic year are based on the parliamentary vote for the financial year which came to an end on March 31 last, and that was the year in which the vote was at its maximum. The grants for this academic year naturally show no reduction. On the contrary, they have increased because they are based on the increased vote.

The fall in the grants to universities will, of course, occur in the academic year ending in July 1923, and will be the direct and inevitable result of the reduction of the parliamentary vote for the financial year ending in March next. The reduction in the grants assigned to the various institutions in the financial year 1922-23 is seen to be no less than 113,905*l.*; but the loss in the academic year 1922-23 will be much greater than this, the difference being due to the fact that the amounts of grant shown in the estimates for 1921-22 are a good deal less than the sums actually received by the universities in the academic year 1921-22, being made up of three parts, namely:

- (a) "Annual grant" for the second half of the academic year 1920-21 (before the vote had been increased by 500,000*l.*).
- (b) "Annual grant" for the first half of the academic year 1921-22 (after the increase in the vote).
- (c) What has been called a "non-recurrent grant," but might more correctly be termed a recurrent grant of variable amount.

It is obvious that, as the first of these three factors is based on the earlier low rate of grant, the total of the three will be considerably less than the aggregate of the grants received by the universities in the academic year 1921-22. Although exact figures are not available, there is reason to suppose that the actual fall in the academic year 1922-23, as compared with the present academic year, will be not far short of 250,000*l.*

If the smaller vote proposed for the current financial year is approved by Parliament, a large reduction in the university grants next academic year is a result which cannot be avoided. But even so, it may be urged, the universities will still receive considerably more than in 1920-21. This view, however, ignores two important considerations. First, the increase in the vote in 1921-22 was justified by the pressing need of the universities for additional aid, and the only reasonable ground for criticising it was that it was on too small a scale. Second, the increased vote encouraged the University Grants Committee to add

to the grant list certain institutions—notably Oxford and Cambridge Universities and the clinical units of the London Medical Schools—which had not previously figured on the list. These new commitments, totalling approximately 120,000*l.*, undertaken on the strength of the enlarged vote, remain a permanent charge on the reduced vote.

The statement which has been made, and has given rise to some misconception, that the annual grants to the universities will be maintained at their present level, depends for its truth on what is little more, in fact, than a technicality.

In allocating to the universities the money voted by Parliament, the University Grants Committee has adopted the practice of giving only part of the money in the form of "annual grants" and the remainder (except what is kept in reserve) in the form of grants (called "non-recurrent"), the amount of which is decided in the case of each university each year. Whatever may be thought of this method of allocating the money voted by Parliament, and whatever these grants may be called, the fact remains that they have been made this year and in previous years, and that they will not be made next year. A reduction of a quarter of a million in the income of the universities is no less a reduction of a quarter of a million because the money lost has not been technically called an "annual grant." It must also be understood that it is not because the universities have not needed the whole of the money voted by Parliament that some of it has been treated by the "non-recurrent" method and some kept in reserve. The whole of the money, and much more than the whole of it, is sorely needed by the universities, and no amount of discrimination between grants of one denomination and grants of another denomination can alter the fact that the amount coming to the universities next year will be about a quarter of a million less than the amount received this year. Such a reduction must deal a very serious blow at the efficiency of university education in Great Britain.

### The New Astronomy.

*The New Heavens.* By Prof. G. E. Hale. Pp. xv+88. (New York and London: C. Scribner's Sons, 1922.) 7s. 6d. net.

IT is impossible not to be impressed by the wonderful story of astronomical achievement told by Prof. Hale in felicitous language in this little volume. Before the invention of the telescope not more than about six thousand stars had ever been seen by human eyes, and less than half this number at any one time. The small telescope, with an object-glass an inch or

so in diameter, used by Galileo in 1610, brought within the range of vision stars down to magnitude 10.5, numbering about five hundred thousand. The 60-inch reflector of the Mount Wilson Observatory, Pasadena, of which Prof. Hale is director, reveals stars of the 18th magnitude, and the 100-inch carries the sounding-line still further, while with both instruments many stars can be photographed which the eye cannot see directly, the photographic limit with four or five hours' exposure being about the 20th magnitude.

The expansion of the stellar universe as regards the number of stars in it which can be seen or photographed represents, however, only a small part of modern astronomical discovery. The test of a telescope is its resolving power, and this is expressed with sufficient accuracy by the relation  $5''/d$ , where the numerator is the normal angular limit of separation of a double star and  $d$  is the diameter of the object-glass in inches. The separating power of the 36-inch refractor of the Lick Observatory is thus  $0''.14$ , and that of the 100-inch of the Mount Wilson Observatory  $0''.05$ . By the use of the interferometer, the latter limit is reduced to  $0''.02$ , and this increase in resolving power was established by observations of Capella. More than twenty years ago, this star was found by Campbell and Newall to be a spectroscopic binary (that is, to consist of two stars in motion about a common centre of gravity and so close together that the system is known to be duplex only by detecting differences, due to orbital movement, exhibited by the composite spectrum), and determination of the orbit showed that the separation of the components could not exceed  $0''.06$ . It was, therefore, within the theoretical limit of separation into its components by the use of Michelson's interferometer on the 100-inch telescope of the Mount Wilson Observatory. Observations made at the end of the year 1919 and the beginning of 1920 confirmed the accuracy of this conclusion, and the distance between the two stars of the pair was found on several occasions to be about  $0''.045$ .

The capacity of the interference method was thus established by these observations with a test-object among the stars. Thirty years previously the method had been used to determine the diameters of Jupiter's chief satellites, but it was only when the 100-inch telescope had been completed that Prof. Hale suggested the application of the principle to the measurement of diameters of stars—a more difficult problem than that of separating close doubles. Prof. Eddington, in his presidential address to Section A of the British Association in 1920, gave the probable angular diameters of some stars and remarked that "the star with the greatest apparent diameter is almost certainly Betelgeuse, diameter  $0''.051$ ." Measurements with

the 20-foot interferometer on December 13, 1920, gave an apparent diameter of  $0''.047$ , which is as striking a confirmation of theoretical deduction by observed result as that represented by the discovery of the planet Neptune. The parallax of Betelgeuse is uncertain, but there are reasons for believing it to be about  $0''.02$ , which would make the diameter of the star about 215,000,000 miles, or 250 times greater than the diameter of the sun. Antares has similarly been found to have a diameter of 400,000,000 miles and Arcturus of 21,000,000. These stars are in an early stage of stellar evolution—attenuated masses of matter low down on the ascending side of the temperature curve of Lockyer's meteoritic hypothesis—and from "giants" they will be transformed to "dwarfs" as they contract and increase in temperature.

Prof. Hale devotes particular attention to the various stages of growth and decay as indicated by modern studies of stellar types, and shows that they afford no direct evidence in favour of Laplace's theory of the formation of planets in our solar system. Recent investigations have truly revealed "The New Heavens," which he describes so clearly and illustrates so attractively with some of the most remarkable astronomical photographs ever obtained. In his last chapter, entitled "Cosmic Crucibles," he deals particularly with the sun as a star and some of the discoveries in the field opened by him by means of the spectroheliograph, which enabled him to prove that every large sun-spot is an electric vortex producing a magnetic field. As helium was discovered by Lockyer in the sun long before it was isolated on the earth, so in the laboratories of the heavens conditions are now continually being studied which not only enlarge our conceptions of the universe but also provide physicists and chemists with results of outstanding interest and value. No one is more competent than Prof. Hale to survey this great territory of which he is the leading pioneer explorer, and his account of the methods used to examine it and the rich store of new knowledge gathered from it, makes as fascinating a scientific story as ever was told.

R. A. G.

### Index Animalium.

*Index Animalium.* A Carolo Davies Sherborn, Sectio Secunda 1801-1850. Part 1: Introduction, Bibliography and Index A-Aff. Pp. cxxxi+128. (London: British Museum (Natural History), 1922.) 20s.

WE congratulate Mr. C. D. Sherborn on the appearance of the first instalment of the second part of his great work. Since the first part was published in 1902, zoologists have eagerly awaited its continuation,

and we hope that the remainder will now follow with all speed, for the real value of the work can be fully appreciated only in its complete form.

The second part follows closely the form and arrangement of the first. After an explanatory introduction there follows the bibliography, from which the stupendous nature of the task which has occupied the best thirty-one years of Mr. Sherborn's life can be judged. One hundred and thirty-one pages of closely printed matter in small type are required to give the titles of the publications which the author has indexed. Against this, less than two pages of similar type, giving the publications to which the author has not had access (some of these have been seen since the list was set up in print) represent an almost negligible part of zoological literature that has not passed through his hands.

When it is remembered that, but for some 5000 entries made for the author by friends, the whole of the literature has been examined and every entry in the index recorded from the original, arranged, sorted, checked and passed for press by Mr. Sherborn himself, we begin to realise something of the debt which zoology, now and for all time, owes to the author. The personal equation has been reduced to a minimum, and Mr. Sherborn's accuracy, which has stood the severe test of the first part of this index, is a guarantee of the absolute reliance which can be placed on the second part. The author has given valuable bibliographical notes to the literature he has examined, and has smoothed the path of systematic zoologists considerably by indicating where that literature is to be found in England and whether it contains new names or any information likely to be of use.

The "Index Animalium" should henceforth be regarded as the bible of systematic zoology. It seems to us that all the vexed questions of nomenclature and priority could be settled by a reference to its pages, and the time and labours of systematists freed for the more complete examinations of the animals themselves. Acknowledgments are due to the Committee of the British Association and to the Trustees of the British Museum for the financial assistance they have given to this work, and to the latter body for assuming the responsibilities of publication. It is only fitting and proper that the most important centre of systematic zoology in the world should undertake the issue of this invaluable and indispensable work, and we are grateful to the Trustees of the British Museum for having done so.

A word of praise is due, too, to the printers and publishers for the admirable way in which this instalment has been printed and for its freedom from errors. We have detected no typographical mistakes in a fairly

close scrutiny. Sir Sidney Harmer in his preface refers to the index as a "labour of love," and we can but inadequately express our thanks to Mr. Sherborn for his magnificent and untiring work. We may, perhaps, be allowed to express our pleasure in the fact that publication is assured and that the results of Mr. Sherborn's work will be preserved in permanent form as a splendid monument to his labours in the cause of science.

### Sugar Technology.

- (1) *Cane Sugar: A Textbook on the Agriculture of the Sugar Cane. The Manufacture of Cane Sugar, and the Analysis of Sugar-house Products.* By Noël Deerr. Second (revised and enlarged) edition. Pp. viii+644+xxix plates. (London: Norman Rodger, 1921.) 42s. net.
- (2) *The Manufacture of Cane Sugar.* By Llewellyn Jones and Fredric I. Scard. Second revised edition. Pp. xix+481+270 plates. (London: Duckworth and Co., 1921.) 25s. net.
- (3) *Condensed Description of the Manufacture of Beet Sugar.* By Dr. F. Murke. Pp. v+175. (New York: John Wiley and Sons, Inc.; London: Chapman and Hall, Ltd., 1921.) 15s. net.

(1) **B**EARING in mind the importance of the sugar industry to the British Empire, more especially in its relation to sugar cane, it is not surprising, and distinctly comforting, to know that we are so well supplied at the present time with up-to-date literature on the subject. Mr. Deerr's treatise ranks among the most important, occupying as it has done for the last ten years—and if we include his first smaller work we may say seventeen years, not to mention his "Sugar House Control" published in 1900—a unique position, the subject being treated from both the theoretical and practical standpoints. The long experience of the author as a technologist and an experimentalist had qualified him eminently for the task he undertook, while for the past ten years he has added still further to his previous extensive experience by being associated with the sugar industry in Cuba and with a sugar refinery in New York. The first edition of Mr. Deerr's treatise was published in 1911. The present edition covers 52 additional pages, each containing some 11 per cent. more words, in addition to which it has been completely rewritten. The reputation of the author is so well known and generally admitted that it is a guarantee at once that his task has been carried out with thoroughness. It is worthy of note, however, that his MS. has been submitted to the following authorities, to whom he acknowledges his thanks for help and criticism: Mr.

J. Hamill, Dr. C. A. Browne, Dr. C. A. Barber, Dr. E. J. Butler, and Mr. J. P. Ogilvie.

It is impossible to deal in detail with such a voluminous work as the one before us; it must suffice therefore to point out that it deals with all phases of the subject—botanical, agricultural, chemical, and technological.

We cordially recommend the volume to all engaged in the sugar industry, as well as to students who intend entering that industry.

(2) The first edition of Messrs. Jones and Scard's treatise was published in 1909, and the fact that a second edition has now appeared is a fitting testimonial, if one were needed by two such eminent and well-known technologists, of its utility as well as of its appreciation by technologists. Mr. Aspinall in the introductory chapter tells us that the first impression of the work was soon sold, and that the authors preferred to prepare a new and revised edition instead of issuing at once a reprint of the first edition.

The work as now presented is in its original form, but it has been thoroughly revised with some 27 additional pages of text and 26 further illustrations. The volume is a welcome addition to the literature, more especially from the technological point of view. A special feature is the large number of well-executed drawings and plans, numbering in all 270, for which the authors are indebted to the leading engineering firms.

The work will be found indispensable to all engaged in the industry, and we welcome its appearance at a time when it behoves sugar-cane technologists, more especially in the British Dominions, Dependencies, and Protectorates, to cultivate the highest efficiency in their subject, and so make the Empire self-supporting as regards sugar. This is a matter which in the writer's personal knowledge one of the authors at least, Mr. F. I. Scard, has long had at heart.

(3) Dr. Murke's little book was written in 1903-5, but was not published. Recently the author found that it could be brought up to date with very few alterations and additions. While it contains much valuable information, the text is of a sketchy character, the sequence is not well chosen, and some important processes find no mention. This being so, it is scarcely to be recommended as an elementary textbook on the subject. However, the author states that it has been written for "superintendents, engineers, and foremen of the beet sugar factory," and such readers would doubtless be able to follow the text without the aid of illustrations, of which there are none.

If we may be allowed to make a few comments, we would point out that while a concise account is given of Stephan's process of recovering sugar as

calcium trisaccharate from molasses, no mention is made that the trisaccharate may be used instead of fresh lime for defecating beet juice. We should have expected to find some reference to the strontium process, but the chapter on the osmose process was scarcely needed; indeed the author himself states that it is almost exclusively an historical one. Most English technologists will prefer the French word "masecuite" instead of "fillmass," the translation of the German "Füllmasse."

Now that we have at least two beet sugar factories at work in the United Kingdom, the demand for works on the subject has naturally increased.

ARTHUR R. LING.

### Geology and Tin Resources of the British Empire.

(1) *The Geology of the British Empire.* By Dr. F. R. C. Reed. Pp. viii+480. (London: Edward Arnold, 1921.) 40s. net.

(2) *The Tin Resources of the British Empire.* By N. M. Penzer. (*The Raw Materials of Industry.*) Pp. x+358. (London: William Rider and Son, Ltd., 1921.) 15s. net.

THE geology of our overseas dominions has been described in a host of publications, many of which are difficult of access and full of local and technical detail. A compact volume, such as the one under notice, in which the outstanding facts concerning the several regions are presented in brief but readable form, cannot fail to meet with a warm welcome. It will appeal not only to students faced with the difficult task of acquiring a general knowledge of world stratigraphy, but also to all who wish to know the larger geological facts of our Empire abroad.

The subject-matter is based upon a course of lectures which the author has given annually for more than a decade. It has not been hastily compiled, therefore, but is the result of many years of wide reading and judicious condensation. Only those who have tried to assemble within a small compass the salient information concerning the geology of countries like Canada, India, or South Africa will be able to gauge the extent of the author's labours or to thank him adequately for placing the results of them at the disposal of the public.

No description is given of the geology of the British Isles, numerous works on this subject being available. The first region dealt with is the Mediterranean, including Gibraltar, Malta, and Cyprus. Egypt follows, reminding us of the rapidity of Empire changes in these days of awakened national aspirations. In the next chapter, dealing with East Africa, an account is given of the geology of Somaliland, Kenya Colony,

and Tanganyika Territory. Then follow two chapters containing a most useful summary of the geology of the Union of South Africa. Central and South-West Africa and British West Africa are dealt with in the two succeeding chapters, the latter including some pages devoted to the British Cameroons and Togoland. Canada and Newfoundland are dealt with in two chapters occupying sixty pages, and the Indian Empire in two of sixty-six pages. These are admirable summaries, which are especially welcome in view of the importance and interest of the work which has been done in these lands and of the great volume of literature that has been epitomised. The Malay States, British Borneo, the Indian Ocean islands, and Hong Kong are treated in a chapter on the East Indies. Then come two chapters on the geology of Australia, one on New Zealand, and one on Oceania, some account being included in the last of territory acquired since the war. The last chapter, under the title of the Mandatory Regions, deals with Mesopotamia and Palestine.

In most cases the descriptions of the several regions are accompanied by sections and folding geological maps in black and white. These are printed on good paper, and students would derive considerable benefit in tinting them with washes of colour. In connection with each area a useful bibliography is also given, which, by referring readers to further sources of information, adds greatly to the value of the book.

Both author and publisher are to be congratulated upon having produced an important and most useful addition to British geological text-books.

(2) Mr. Penzer's book is of a more specialised kind. It is the second of a series devoted to the raw materials of industry, the first of which dealt with cotton and wool throughout the world. This second volume restricts itself to tin within the Empire, which, constituting two-thirds of the world's supply, provides ample material for a single volume. It is proposed to issue later another volume describing the extra-British sources of the metal.

The introduction deals with the history of tin production and with the tin-bearing minerals. Then there are four chapters describing the various fields, arranged according to continents; this part of the book contains much detailed information, and is illustrated by a number of specially drawn distribution maps. There is also a chapter on the industrial applications of tin, and one giving statistics as to output, prices, and conditions of sale. The volume closes with an elaborate classified bibliography.

A perusal of this book has left the impression that its writer has been assembling information upon a subject which is outside the limits of his own practical

experience. This impression detracts a little from the authority of the work, but it must not be allowed to obscure the fact of the author's remarkable industry or of the extraordinary amount of information which he has gathered together into the 350 pages of his book. By indefatigable labour he has made a valuable compilation which many interested in the mineral industries will be glad to possess and keep by them for purposes of reference.

C. G. C.

### Our Bookshelf.

*The Vitamins.* By Prof. H. C. Sherman and S. L. Smith. (American Chemical Society: Monograph Series.) Pp. iii+273. (New York: Chemical Catalog Co., Inc., 1922.) 4 dollars.

A very welcome addition to the literature of vitamins has been provided by Prof. Sherman and Mr. S. L. Smith in the volume under notice. The plan of the book is very simple; an historical introduction is followed by three chapters devoted to the three generally recognised vitamins and a final chapter is added on the relation of these important principles to the problem of food supply. A bibliography is also given, which comprises about a thousand entries and includes the literature so far as the end of 1921.

The treatment of the subject is throughout clear and critical, and the authors err if at all on the side of caution. Thus they do not regard the identity of the water-soluble and antineuritic vitamins as proved, but consider that "the preponderance of evidence thus far available favours the view that the water-soluble, growth-promoting vitamin is probably among the substances which may exert antineuritic action." They display a similarly open mind as to the vexed questions of the nature of vitamin B and its relation to the growth of yeast, which are both being actively investigated, with tantalisingly varied results, in many laboratories. The concluding chapter will probably be found the most interesting by the non-specialised reader, as in it the authors discuss the commonly used foodstuffs from a general point of view, devoting attention to their special merits or demerits, not only as carriers of vitamins but as sources of "good" or "bad" proteins and of energy. Their final conclusion brings comfort to those who are anxious as to the suitability of their everyday diet: "... we believe it safe to say that with a dietary selected to make the best use of our ordinary staple foods there will rarely if ever be occasion to purchase vitamins in any other form, or to give any greater anxiety to the vitamins than to some other factors which enter into our present conception of nutritive requirements and food values."

*Essai philosophique sur les probabilités.* Par Pierre-Simon Laplace. (Les Maîtres de la Pensée Scientifique: Collection de mémoires et ouvrages. Publiée par les soins de Maurice Solovine.) I. Pp. xii+103. II. Pp. iv+108. (Paris: Gauthier-Villars et Cie, 1921.) Each vol. 3 francs net.

OUR students spend little or no time in the study of the classical documents of scientific discovery. This neglect is very much to be regretted, for there can be

no doubt that nothing is so inspiring and fascinating as the perusal of the account of a great discovery by the discoverer himself. The personal element, so conspicuously absent in current textbooks, is in this way given its opportunity, especially if the discoverer's account is read in the original language in which it was written. The series now being issued under the editorship of M. Solovine is therefore to be welcomed.

The present essay was first printed as an introduction to Laplace's "Théorie analytique des probabilités." It gives in non-mathematical language the principles underlying Laplace's methods for dealing with the theory of probability, and shows how it is applied to problems of natural science—especially the astronomical problems to which Laplace applied his genius—to sociology and other aspects of communal life. Special attention is devoted to errors in the estimation of probabilities, due to psychological causes, and there is also a brief history of the methods of probability.

Considerable modification has since been introduced into the fundamental notion of probability, but Laplace's essay should be read by all students of mathematics. In it occurs the sentence: "Une intelligence qui pour un instant donné connaîtrait toutes les forces dont la nature est animée et la situation respective des êtres qui la composent, si d'ailleurs elle était assez vaste pour soumettre ces données à l'analyse, embrasserait dans la même formule les mouvements des plus grands corps de l'univers et ceux du plus léger atome: rien ne serait incertain pour elle, et l'avenir comme le passé serait présent à ses yeux." S. BRODETSKY.

*Displacement Interferometry applied to Acoustics and to Gravitation.* By Prof. Carl Barus. Pp. viii + 149. Publication 310. (Washington: Smithsonian Institution of Washington, 1921.)

PROF. BARUS' work is divided into twelve chapters, and occupies an intermediate position between the usual textbook dealing with routine work and the ordinary type of original research which attacks and solves some specific and definite problem. It is throughout of an exploring nature and may be said to investigate the suitability of interferometry as a method for research in various branches of acoustics and gravitation. In the first chapter the open mercury manometer, when read by interference, is discussed. In the second, the interferometer U-tube is used as an absolute electrometer. The third deals with acoustic pressures, the fifth treats of the compression of a sound wave in a pipe, and the sixth with the vibration of a telephone plate. In the eighth and following chapters various gravitational problems are approached. The book is a storehouse of unusual experimental methods and may be consulted with advantage by any one about to commence investigations along the lines indicated.

*Publications of the Washburn Observatory of the University of Wisconsin.* Vol. X. Part 4: *Observations of Double Stars, 1907-1919.* By George C. Comstock. Pp. 167. (Madison, Wis.: Washburn Observatory, n.d.)

THE volume under notice forms a catalogue of all the observations of double stars made with the 16-inch refractor at Washburn Observatory by Prof. Comstock

between 1907 and 1919; summaries of his earlier observations with the same instrument from 1889 to 1907 are also given, so that it is possible to detect changes. There are some 200 stars in the catalogue, including most of the well-known binaries.

The probable errors are given as  $2^{\circ}.6$ ,  $0^{\circ}.03$  for separations less than  $0^{\circ}.5$ , and  $0^{\circ}.9$ ,  $0^{\circ}.07$  for those between  $2''$  and  $4''$ . Wires illuminated by red light were employed. This involves the possibility of small errors through unequal refraction of the images of wire and star in the eyepiece, unless the latter is achromatic. A list is given of the eyepieces, which are either Ramsden or Kellner, with powers varying from 196 to 1540; about 800 was commonly used. A. C. D. C.

*Drugs in Commerce: Their Source, Preparation for the Market, and Description.* By J. Humphrey. (Pitman's Common Commodities and Industries.) Pp. xi + 116. (London: Sir Isaac Pitman and Sons, Ltd., n.d.) 3s. net.

MR. HUMPHREY has contrived to include within the moderate compass of 113 pages of text a good account of the drugs of natural origin found in commerce. The information given includes descriptions of the drugs, notes on their constituents and sources of supply, and in most cases some particulars as to their modes of preparation for the market. Great pains have evidently been taken to secure accuracy, but it should have been pointed out that the "henbane" imported from Egypt is not derived from *Hyoscyamus niger*.

The book contains six plates illustrating the more important drugs, e.g. cinchona, ergot, opium, and jaborandi, and six more showing scenes in drug warehouses at the London Docks and methods of packing and selecting the spices, such as nutmeg and cinnamon, used in medicine. The book can be cordially recommended to any one desirous of obtaining general information regarding this interesting and little-known group of commercial products.

*Memoirs of the Geological Survey: England and Wales. The Water Supply of Cambridgeshire, Huntingdonshire, and Rutland from Underground Sources.* By W. Whitaker. Pp. iv + 157. (Southampton: Ordnance Survey Office; London: E. Stanford, Ltd., 1922.) 7s. net.

THE latest addition to the series on the underground water supplies of England deals with three counties which form a convenient unit. The counties being agricultural rather than industrial or manufacturing, very large water supplies are required in few cases. Supplies are obtained chiefly by means of wells, but some water is obtained from springs, notably the supply of the town of Wisbech, which, however, obtains its water from the county of Norfolk. At least one town of more than 5000 inhabitants seems to have no public supply. Chalk and, to a less extent, lower greensand are the sources of water in these counties. The Oolites and Lias are also of some importance. The value of chalk in this respect in the south-east of England corresponds with that of New Red sandstone in the Midlands. In addition to full details of the wells and springs in the three counties Mr. Whitaker gives some useful indications as regards enlarging and improving existing supplies.

### Letters to the Editor.

[The Editor does not hold himself responsible for opinions expressed by his correspondents. Neither can he undertake to return, or to correspond with the writers of, rejected manuscripts intended for this or any other part of NATURE. No notice is taken of anonymous communications.]

#### The Stature of the Scottish People.

On the data published in the "Final Report of the Anthropometric Committee" of the British Association (1883), the Scottish people have been regarded as being considerably taller than any other British nationality. The following letter from Dr. Aleš Hrdlička, of the United States National Museum, Washington, D.C., shows that, through an error in computation, the Scots have had nearly two-thirds of an inch added to their real stature.

"In preparing my report on the 'Stature of the Old Americans' I had occasion to look up, among other things, the principal records of that nature on the Scotch people. I found quite a number of these and they all showed fairly harmonious results, with one exception. This was the record on the Scotchmen in the 'Final Report of the Anthropometric Committee' of the B.A.A.S., 1883, p. 256. This record gave results that were so much higher than any others that I was finally led to a re-computation of the series. Taking the number of persons measured and the record in inches, in which the measurements were originally recorded, I found to my surprise a different and a very perceptibly lower average. The averages given in the Report were 68.71 in. or 174.6 cm., while I obtained 68.1 in. or 172.97 cm.

"I should be thankful to you if you would bring this matter to the attention of the members of the Anthropological Institute, and have it looked into; and if it should be found that an error has been made, then I think it would be advisable for some one to publish a little note on the subject, for the figures of the Anthropometric Committee have been widely utilised (see Deniker, Martin, etc.)."

I have not checked Dr. Hrdlička's estimates, but I have no doubt that they are right. The average stature of the four British nationalities thus amended reads: Scottish, 172.9 cm.; Irish, 172.6 cm.; English, 171.2 cm.; Welsh, 169.4 cm.

ARTHUR KEITH.

#### Advanced Mathematical Study and Research at Cambridge.

It has been suggested to me that attention might well be directed through the columns of NATURE to a point in the regulations of the University of Cambridge which prevents many graduates of other universities taking advantage of the opportunities Cambridge offers for advanced mathematical study.

In most universities other than Cambridge our best students of mathematics now usually read for a degree in science. They have passed an entrance examination of a standard far higher, I need scarcely say, than that of the Previous Examination. But neither in their entrance examination nor in their course need they have taken Latin or Greek. They are thus cut off from the privileges of affiliation, which include exemption from the Previous Examination and permission to take their degree on Part II. of the Tripos after a residence of two years.

It is true that graduates of other universities may

proceed to the degrees of M.Sc. and Ph.D. at Cambridge by research, without any questions being asked as to the nature of their entrance examination. But in my opinion, at least, few of the graduates of the Scotch universities, the newer English universities, and the universities of the Dominions are ready to devote themselves to research in mathematics immediately after graduation. What they want at that stage is just such advanced instruction as Cambridge now offers in the subjects of Schedule B of Part II. of the Tripos. They should be able to take the Part II. examination easily after six terms. Before the end of that time they may have begun some research. But the man who wishes to become a professional mathematician should continue research work for at least two years after taking Part II. Some of the time would be spent at Cambridge; and one or other of the great schools of mathematics at Paris, Rome, Berlin, or Göttingen should certainly be visited.

Oxford admits to the status of Senior Student any person who has obtained a degree at an approved university after a three-year course, the degree also having been approved by the Hebdomadal Council. If Cambridge would modify its regulations for admission to the privileges of affiliation so that our best graduates in mathematics could take the Cambridge B.A. on Part II. after six terms, I believe its school of mathematics would receive a larger number of brilliant scholars, and there would be more of our mathematicians at home and abroad engaged in research.

H. S. CARSLAW.

The University, Sydney, May 1.

#### Condition of Electrolytes in the Blood.

ARE the salts present in the blood ionised to an equal extent as similar concentrations of these salts in aqueous solution? Are the ions absorbed by the protein? These are questions that have been attracting the attention of physiologists and biological chemists. Investigators have attempted to answer these questions principally by two methods—compensatory dialysis of the serum (Rona, Michealis, and their co-workers) or filtration with pressure (Starling, Cushny, Richter-Quittner).

It seemed worth while to determine the concentrations of other ions by electromotive force measurements, as is done in the case of the hydrogen ion. Accordingly, a 0.2 per cent. sodium amalgam that is but slowly decomposed was used as a sodium electrode. After measuring the E.M.F. of this electrode against known concentrations of sodium chloride of known degree of ionisation, the normal potential of this amalgam electrode was obtained. The E.M.F. of samples of serum and plasma were then measured. When from these readings the total concentrations of Na present were recalculated on the basis that the degree of ionisation of the sodium salts was the same as in an aqueous solution, the calculated Na concentration and that found by analysis were in very good agreement. For example in two samples the calculated values of sodium were 3.51 and 3.67 grams; the values found were 3.46 and 3.65 grams per litre. Thus the conclusions of the aforementioned workers that Na is not bound in the serum, because it can be dialysed and filtered *in toto*, has been confirmed.

To determine the concentration of Cl-ions, an Ag/AgCl electrode was used. By calculations similar to those outlined in the case of sodium, it was found that the quantities of Cl present calculated from E.M.F. measurements of serum and plasma, on the assumption that we were dealing with an aqueous



solution of sodium chloride, were in good agreement with those found by analysis. Thus in two samples, for example, the totals for chlorine calculated as NaCl were 6.443 and 6.541; the totals found were 6.535 and 6.61 grams. Chlorine likewise is apparently as free as in an aqueous solution.

The writer is at present developing a calcium electrode to determine the state of calcium in the blood.

BENJAMIN S. NEUHAUSEN.

Johns Hopkins University, Baltimore, Maryland.

**The Dimensions of Area.**

In my "Physics," pp. 423-426, it is maintained that it is incorrect to attribute to area (or volume) the dimensions  $L^2$  (or  $L^3$ ); but no example of an error arising from such attribution could be given. It has since occurred to me that an excellent and important example is provided by Child's high vacuum current law, according to which  $\sigma$ , the current density, is proportional to  $\left(\frac{e}{m}\right)^{\frac{1}{2}} \frac{V^{\frac{3}{2}}}{F}$ .

The laws assumed in the deduction of this relation are (1)  $\frac{V}{l} \cdot A = a \cdot e$  (Poisson's equation), (2)  $\sigma \cdot l \cdot A = \beta \cdot e \cdot v$ , (3)  $m \cdot v^2 = \gamma \cdot e \cdot V$ , where  $A$  and  $v$  are area and velocity, and  $a, \beta, \gamma$  formal constants or no-dimensional magnitudes. If in place of  $A$  we write  $F^2$ , we find that  $\sigma^2 l^2 m \left(\frac{l}{e}\right)^n V^{n-4}$  is no-dimensional for all values of  $n$ . The solution is ambiguous and the Child relation is not deducible by dimensional argument, as it clearly ought to be. If, on the other hand, we retain  $A$ ,  $\sigma^2 l^2 \left(\frac{m}{e}\right) V^{-3}$  is the only no-dimensional magnitude independent of  $A$  and  $v$ ; we obtain a unique and correct result.

The removal of the ambiguity must be due to the introduction of some additional law. This additional law is that the ratio of the area in (1) to the area in (2) is independent of  $l$ , or that  $l$  is perpendicular to  $A$  in both cases, or that the electrons follow the lines of force. If we omit the important magnitude shape in stating the dimensions of  $A$ , this law cannot be introduced into the dimensional argument, because there remains no magnitude to measure direction.

The additional law is not quite strictly true because of the inertia of the electrons. It follows, therefore, that if the electrodes are arranged so that the curvature of the lines of force is very great, small departures from the Child relation are to be anticipated. But so long as the curvature is small, the relation will hold if the systems compared are geometrically similar, differing only in their size  $l$ . So far as I know, the relation has hitherto been proved only for parallel plane and concentric cylindrical electrodes; experimentally it is known to be true over a much wider range.

NORMAN R. CAMPBELL.

19 Holland Park, W.11, June 4.

**The Resonance Theory of Hearing.**

MR. ACKERMANN (NATURE, May 20, p. 649) is probably correct when he states that the first incoming sound wave sets all the resonators of the ear temporarily in vibration, and also, that as the sound waves continue the vibrating resonators decrease in number until only those are left in motion that are executing either sympathetic or forced vibration in time with the incoming sound waves. But surely he has left out of account the probable

amplitude of the motion performed by the resonators, and the probable physiological properties of the mechanism, when he judges the intensity of the sound stimuli sent along the auditory nerve to the brain to be directly proportional to the number of resonators that are swinging at any moment?

At the present time we have practically no information concerning the type of response given by the auditory nerve. It may, like certain motor nerve fibres, obey the all-or-nothing law, or it may conduct with a decrement, or it may be graded in its response. But in all these cases the amplitude will be an important factor in deciding the response given by any one hair cell and nerve fibre. But there are, I think, other physiological factors which Mr. Ackermann has overlooked. For although we cannot directly stimulate the hair cells of the cochlea electrically and ascertain the approximate relationship between strength of stimulus and strength of response, so that we can demonstrate clearly that the auditory mechanisms have such physiological properties as threshold, latent period, simultaneous and successive contrast (as we can, for example, in the case of the skin end organs), yet we have sufficient evidence that these properties are exhibited also by the auditory mechanism as by the other organs of special sense. Reconsidering now the case that Mr. Ackermann has taken, and assuming as a basis for calculation—

- (a) that the sound wave energy entering the ear in unit time is constant;
- (b) that the pitch is constant;
- (c) that the mean amplitude of all the resonators in vibration at any one time is inversely proportional to the number in vibration; and
- (d) that the energy available for distribution is proportional to the length of time during which the sound waves have been arriving, i.e. that none of the energy entering the cochlea has been lost in eddies, friction, etc.;

the following table shows the number of oscillators in vibration and their mean amplitude:

No. of Sound Waves from Common Cement.	No. of Resonators in Vibration.	Mean Amplitude.
1	6000	·003
2	1000	·03
3	600	·08
4	450	·13
5	350	·21
6	290	·31
7	240	·44
8	200	·60
9	170	·80
10	150	1·00

It will be seen that after one sound wave 6000 resonators are in vibration with an amplitude of 0.003, whereas after 10 sound waves 150 resonators only are swinging with an amplitude of 1. The table shows that there is a rapid increase in the mean amplitude of the vibrating resonators at the commencement of a tone.

There is no pretence of any exactness in the above values. They merely illustrate the kind of results to be expected. It should be noted further that at any instant those resonators approximately "in tune" with the incoming sound waves will have amplitudes considerably greater than the mean value, others nearest to those which are coming to rest will have amplitudes less than the mean value.

Therefore, even after one complete sound wave there will be already a clearly marked selection of the "in-tune" group of resonators.

Taking now the physiological effects into consideration, the threshold factor will definitely rule out all amplitudes below a certain value, so that after a certain number of sound waves have entered the ear the amplitude of the "in-tune" resonators will be the first to rise above the threshold and will cause impulses to pass up the auditory nerve. A little later a larger number of resonators will have reached amplitudes above the threshold, so that there should be a gradual increase in the number of resonators in active response, until the full steady value is reached. Calculation shows that the "in-tune" resonator should attain 90 per cent. of its final amplitude in eight vibrations. On the resonance theory one would therefore expect a gradual rise in the sound intensity occurring in a time interval of the order of 10-20 vibrations of the incoming sound waves (i.e.  $1/25-1/12$  sec. for middle C), and not a fall as Mr. Ackermann has suggested in his letter. It would seem that this effect is responsible for the absence of roughness at the commencement of a tone due to the imperfection of the transient vibrations of "out-of-tune" resonators.

Now if the rise of sound intensity is a gradual one, what, it may be asked, is the mode of perception of a tone which starts with large amplitude and gradually diminishes as it goes on—e.g. a piano note? In such a case it would seem that after a very few vibrations, the swings of the resonators must reach such an amplitude that their motion is perceived. In this case, then, the vibration of "out-of-tune" resonators makes itself perceived because the auditory nerve fibres are taking up responses before there have been sufficient incoming sound waves to damp out the "out-of-tune" resonators. It would seem to be this effect which gives the transient harshness to the commencement of a piano note, causing it to sound to the ear as if it started with a consonant.

H. HARTRIDGE.

King's College, Cambridge.

#### An Experimental Towing-tank used by Benjamin Franklin.

IN the "Calendar of Industrial Pioneers" in NATURE, May 6, p. 598, relative to the anniversary of William Froude, your correspondent says: "His (Froude) work led to the construction by the Admiralty of the experimental tank at Torquay, the first of its kind ever built."

It will be doubtless interesting to readers of NATURE to have it brought to their attention that Benjamin Franklin in his many and varied investigations in philosophical subjects investigated, to some extent, the difference of navigation in shoal and deep water. In a letter written to Dr. John Pringle, May 10, 1768, he gives the results of experiments made along these lines. The letter tells of how, during a trip with Dr. Pringle in Holland, it was brought to their attention that the *treckschuyt* in one of its trips went slower than usual, due, as the boatmen explained, to the water in the canal being low. After his return to England, not being entirely satisfied with the boatman's explanation, Franklin questioned the Thames river watermen and found them all agreeing as to fact, but differing widely in expressing the quantity of the difference. He, therefore, designed the following experiment, which in its nature is a forerunner of the modern towing-tank. I quote from his letter:

"I provided a trough of planed boards fourteen feet long, six inches wide, and six inches deep in the clear, filled with water within half an inch of the edge, to represent a canal. I had a loose board, of nearly the same length and breadth, that, being put into the water, might be sunk to any depth, and fixed by little wedges where I would choose to have it stay, in order to make different depths of water, leaving the surface at the same height with regard to the sides of the trough. I had a little boat in form of a lighter or boat of burden, six inches long, two inches and a quarter wide, and one inch and a quarter deep. When swimming, it drew one inch water. To give motion to the boat, I fixed one end of a long silk thread to its bow, just even with the water's edge; the other end passed over a well-made brass pulley of about an inch diameter, turning freely on a small axis; and a shilling was the weight. Then, placing the boat at one end of the trough, the weight would draw it through the water to the other.

"Not having a watch that shows seconds, in order to measure the time taken up by the boat in passing from end to end, I counted as fast as I could count to ten repeatedly, keeping an account of the number of tens on my fingers. And as much as possible to correct any little inequalities in my counting, I repeated the experiment a number of times at each depth of water, that I might take the medium. And the following are the results:

	Water, 1½ inches deep.	2 inches.	4½ inches.
1st exp.	100	94	79
2nd "	104	93	78
3rd "	104	91	77
4th "	106	87	79
5th "	100	88	79
6th "	99	86	80
7th "	100	90	79
8th "	100	88	81
	813	717	632
	Medium 101	Medium 89	Medium 79

PAUL C. WHITNEY.

U.S. Coast and Geodetic Survey,  
Washington, D.C., May 22.

#### An Experimental Confirmation of the Kinetic and Molecular Theories of Magnetism.

CURIE'S law states that ferromagnetics above the critical temperature behave in such a way that the susceptibility ( $k$ ) is inversely proportional to the absolute temperature ( $T$ ), in short, that the product  $k \cdot T$  is a constant. The physical meaning of this law is that when the molecular magnets have complete freedom of rotational movements, the energy of magnetisation is then only opposed by the energy of thermal agitation and, consequently, any given state is a state of equilibrium.

Below the critical temperature complications introduced by the mutual magnetic actions of the molecules, one on the other, and by the approach to a saturation limit have obscured any such simple law. It is, however, possible to eliminate, or allow for, the effects of these disturbing factors and to make experiments, under hysteresis-free conditions, upon the variation of susceptibility with temperature. Experiments of this kind have been carried out on

iron and nickel, and the reduction of the observations has now been completed, with the result that the Curie law, with certain limitations, is found to apply to the ferromagnetic state, and the relation  $k \cdot T = a$  constant is approximately satisfied, but the constant now is of a very different magnitude from the former one. There is, however, this simple and important relation between the constants in the two states—their ratio is the kinetic energy per unit of temperature per gram of two degrees of freedom, and is thus immediately connected with the gas constant R. This result is of importance because it shows that the change from the ferromagnetic to the paramagnetic state is quantitatively explicable as due to the acquisition of the kinetic energy per unit temperature required for the two degrees of rotational freedom which are effective in controlling magnetic susceptibility.

Thus there is proof from magnetic data alone, independently of thermal data, that the change at the critical temperature from ferro- to paramagnetism is due to the gain of energy associated with two degrees of freedom.

This acquisition of energy-content makes itself evident in the increase of specific heat which ferromagnetics show at and above the critical temperature, and is quantitatively in agreement with the magnetic result.

It is no longer necessary now to assume, as has been done, that an immense intrinsic magnetic field is the cause of ferromagnetism, although it may be convenient to introduce a fictitious magnetic field such that it will give rise to energy effects equivalent to the energy of two degrees of freedom.

The results which have been discussed above are also a confirmation of the simple view advanced by Ewing in his earlier papers on the molecular theory of magnetism, in which he suggests that the loss of ferromagnetic qualities may be caused by the oscillations of the molecular magnets which become wider and wider up to the critical temperature, at which point they pass from vibration to rotation.

J. R. ASHWORTH.

May 30.

### Molecular Anisotropy in Liquids.

A VERY remarkable feature shown by many liquids in experiments on the molecular scattering of light is that the scattered beam in a direction transverse to the primary rays shows a large admixture of unpolarised light, the proportion of this to polarised light in the scattered beam being several times greater than in the case of the same substance in the condition of vapour at atmospheric pressure. This fact seemed at first very puzzling; an explanation is, however, now forthcoming. A theory of the phenomenon has been worked out by the writer which not only explains the facts in a simple and quantitative manner, but has also pointed out the way to further fruitful research. It may be briefly indicated as follows:

The polarised and unpolarised parts of molecularly scattered light may be conceived as arising in two distinct ways; the former is a mass-effect arising from the thermal fluctuations of density in the fluid, and its magnitude is given by the Einstein-Smoluchowski formula

$$\frac{\pi^2}{18} \cdot \frac{RT\beta}{\lambda^4} \cdot (\mu^2 - 1)^2 (\mu^2 + 2)^2,$$

and as we pass from the condition of vapour to that of liquid in which the molecules are more closely

packed together, it increases much less than in proportion to the increased density. The unpolarised part of the scattered light is, on the other hand, a molecular effect, and its magnitude increases simply in proportion to the number of molecules per unit volume. The ratio of unpolarised to polarised part of the scattered light should therefore be considerably enhanced. This is exactly what is observed. If  $I_1$  and  $2I_2$  are respectively the polarised and unpolarised parts of the transversely scattered light, the ratio  $I_1/(I_1+I_2)$  may be determined experimentally by analysis with the aid of a double-image prism and a Nicol. The Table below shows in the second column the value of this ratio as determined by Lord Rayleigh for certain substances in the state of vapour, in the third column the value of the ratio for the liquid state at ordinary temperature as calculated from the writer's theory, and in the fourth column the value as determined by Mr. K. Seshagiri Rao in the present writer's laboratory. The agreement is significant.

RATIO OF COMPONENTS OF POLARISATION

Substance.	Observed, Vapour.	Calculated, Liquid.	Observed, Liquid.
	Per cent.	Per cent.	Per cent.
Ethyl Ether . . .	1.7	10.9	8.2
Benzene . . . . .	6.0	39.8	39.8
Chloroform . . . . .	3.0	18.2	15.5

We may also view the matter in another way. When a substance is in the state of vapour under small pressures, both the positions and orientations of its molecules are absolutely at random, and assuming the molecules to be anisotropic, the degree of imperfection of polarisation of the light scattered by it may easily be calculated, as has been done by the late Lord Rayleigh. On the other hand, in the liquid state, the packing of the molecules is so close that their ordering in space is no longer at random; but we may still, at least in the case of ordinary liquids, consider the orientations to be arbitrary without serious error. If we take this into account in determining the resultant effect of the waves scattered by the individual molecules, we should be led to the same result as has been indicated above.

The theory put forward has other notable successes to its credit. The Einstein-Smoluchowski formula indicates that though the density of a liquid diminishes with rise of temperature, its scattering power should increase and become very large as the critical temperature is approached. Similarly, as the temperature is increased, the scattering power of the saturated vapour should increase much more rapidly than in proportion to its density. Accordingly, in both cases, we should expect the polarisation of the scattered light to improve steadily with rise of temperature and become practically complete as the critical temperature of the liquid is approached. Experiments with benzene liquid and vapour made by Mr. K. R. Ramanathan have quantitatively confirmed this prediction. A similar improvement in polarisation has also been observed by Mr. V. S. Tamma in experiments on the scattering of light in binary liquid mixtures as the critical temperature for separation into two phases is approached.

C. V. RAMAN.

210 Bowbazar Street, Calcutta,

May 11, 1922.

## Recent Investigations of the Lake Dwellings of Switzerland.

By Prof. EUGÈNE PITTARD, University of Geneva.

AS a result of the persistent drought at the beginning of 1921, the level of the Swiss lakes fell considerably, and hitherto unsuspected depths were brought to light. This phenomenon was particularly marked in the three lakes of Neuchâtel, Bièvre, and Morat, in which important areas had already been laid bare by the regulation of the waters of the Jura. Long stretches of beach which, until that time, had not been accessible to the inhabitants of the shore, completely modified the aspect of these lakes.

During the early months of 1921, in those districts in which the men of the polished stone age had built their dwellings, a large number of piles gradually

culture of these ancient populations. We have obtained, to some extent, an insight into their mode of life; we can frame hypotheses as to their race; but there are still many problems which require elucidation. I will indicate here a few of these problems which relate to the neolithic period.

1. We do not yet know with certainty to which ethnological group to assign the builders of the lake dwellings and their successors up to the end of the bronze age. It has been held, on the evidence of bones recovered from among the piles, that this type of habitation was invented or introduced by brachycephals—until that time unknown in Western Europe.



FIG. 1.—Part of the site at Greng, Lake of Morat.

emerged which the present generation had seen only under several feet of water. It was a revocation of vanished ages which appealed to the emotions. It enabled the imagination to reconstruct more readily a picture of those who, thousands of years ago, were the authors of the greatest of social changes when they introduced the cultivation of cereals, the domestication of animals, and the like. From day to day more and more of the substructure of these cities of the lake was uncovered, and from all parts travellers came to look upon this impressive spectacle, which perhaps we shall never see again.

It will be readily understood that such exceptional conditions encouraged Swiss men of science to undertake fresh investigations on several of the lacustrine sites.

The numerous finds which have been made since 1854 in all the lakes which were at one time inhabited by men of the stone age and the bronze age have enabled us to reconstruct, in great part, the material

Further, that this race held its own on the Swiss lakes until the end of the neolithic age, when dolichocephals begin to appear in the lake-dwelling sites, coming, perhaps, from the north. (Their ethnical affinities also are still to be determined. Will our hypotheses stand?)

2. The dispositions of lake-dwelling sites, their town planning, if one may use the phrase, is, in essentials, unknown. Even the extent of the ground they covered in many cases has not been determined exactly.

What exactly was the topographical plan of each site? Were the sites, that is, those of the same epoch and situated on the same lake, arranged on a specific plan, identical throughout, or was a free rein given to the fancy of the builders in each case? In other words, was there a type of lake village, and, if so, what was it? Was the lacustrine city an organic whole, with the houses grouped on one frontage, or was it composed of a series of small islands, and, in that case, what were the dimensions and dispositions

of these islands? Did they communicate with one another by bridges or by navigable canals? If so, what were the measurements and arrangement of these bridges or canals?

What was the form of the dwellings? Those authors who have attempted to reconstruct groups of lake dwellings have differed remarkably in their attempts. These diversities show how little solid basis there is for our knowledge in this matter, notwithstanding the evidence from sites such as Schüssenried, Robenhausen, Niederwil, etc. Was the settlement protected against the waves caused by prevailing winds by some projecting construction—it may be assumed, a stockade of piles?

3. Do the most important of the articles in daily use by the inhabitants of the lake dwellings in the

tions on sites which are always submerged. The diving bell alone can be used. It is for this reason that the persistent drought at the beginning of the year 1921 has proved so favourable to research.

Let us now consider the results which were obtained in the course of recent investigation.

Very few human skeletal remains of neolithic age were found; but an important discovery was made at St. Aubin. In the lowest stratum of this site, which is the oldest of the Swiss neolithic lake-dwellings, M. Vouga found a human cranium, which was sent to me. It is unquestionably dolichocephalic. This is the first piece of definite evidence of this character. Does it affect previous hypotheses as to the race of the builders of the lake-dwellings? I do not think on such slender evidence we can maintain that it does.



FIG. 2.—Part of the Neolithic site at Greng, Lake of Morat.

neolithic period date from the beginning of lake settlements? Were the various types of objects which are exhibited in the cases of our museums invented at different ages in accordance with the growth of needs, or were they in use in the earliest period? This question can be settled finally only by stratigraphical study.

4. Were the five domesticated animals of the neolithic period (the ox, the dog, the pig, the goat, and the sheep) present in the earliest period of the lake dwellings, or may we accept the suggestions put forward by various authors that these domestic animals were introduced gradually during the age of polished stone?

These are a few of the questions which still await an answer, notwithstanding the numerous investigations which have been undertaken since the memorable winter of 1853-54. The solution of these problems is naturally very difficult owing to the nature of the ground upon which investigations have to be carried out. It is not easy to make stratigraphical observa-

The skull in question is feminine, from which fact we may conclude that it belonged to an inhabitant of the site at St. Aubin and not to a foreigner, whose head might perhaps have been brought home as a trophy of war. The discovery, however, is of importance, because it was made in the course of investigations on stratigraphical lines. It is not a skull unearthed at hazard from the mud or sand. It was *in situ*.

In the course of the spring and the summer of 1921, two detailed topographical surveys were made—one, at my suggestion, at Greng in the Lake of Morat (Figs. 1 and 2) by MM. Le Royer and Winkler, the other on the foreshore of Geneva. This is the first time that any work of this character has been undertaken in Switzerland. The station at Greng was not completely surveyed. A record was made of the position of those piles only which were left uncovered by the fall of the lake and of those which were in shallow water. At Geneva, work of considerable extent was undertaken

by MM. Le Royer and Blondel. It has recently been completed (April 1922). Among the conclusions which emerge, it is now clear that the inhabitants of the lake-dwellings in the polished stone age had constructed stockades facing the open water, for protection against the waves raised by the prevailing northerly wind. These breakwaters must have afforded the dwellings relatively smooth water. From these investigations it may also be concluded that the lake-dwelling sites of Geneva were of considerable size. Unfortunately of these there remain to-day only some thousands of piles implanted in the bed of the lake.

Geneva is thus one of the most ancient cities of the world, since man has lived on this site continuously ever since the neolithic period.

The stratigraphical investigations undertaken by M. Vouga enable us to establish with certainty the succession of the types of industrial objects throughout the neolithic period of the lake-dwellings. Several of our *a priori* conceptions based on typology must be abandoned. Thus the pottery of the earliest period is more refined, more beautiful, more highly burnished than that of later periods. In technique it approaches more nearly the pottery of the bronze age than that of the middle and upper neolithic.

Thanks to a careful study of the stratification of objects found at Auvernier, M. Vouga has been able to plot out the progressive modification of several objects in daily use, such as the axe-hafting sockets of stag horn, flint arrow-heads, and the like.<sup>1</sup>

In many cases, however, stratigraphical study has only slightly modified classifications, such as those of Ischer, based upon the typology of lake-dwelling sites which have been investigated with minute care.

Other observations of importance for the history of culture have also been made by M. Vouga:—

The lowest stratum (IV.) has not yet yielded any of the spindle whorls which are necessary for weaving. The art of drilling stone would appear to begin in Stratum III., but only in the triangular axe hammer-head. The true perforated axe hammer-head appears much later—in Stratum I.

In Stratum I.—the latest—appear flint flakes of Grand-Pressigny type. Relations between Switzerland and western France are thus clearly established.

For the first time *all* bones found in the excavation of a lake-dwelling site have been preserved. My

<sup>1</sup> I would refer the reader to the reports published by M. Vouga in "Indications d'Antiquités suisses" in the *Arch. suisses d'Anthrop. Gén.*, Geneva, 1921 and 1922.

assistant, Dr. Reverdin, and myself have examined more than 4000 mammalian bones from the station of St. Aubin. Our conclusions, which are valid only in respect of the material obtained and for this site, may be summarised as follows:—In the neolithic period corresponding with the earliest lacustrine sites, the horse was not domesticated. It was not even hunted, or, if it was an object of the chase, its flesh was not brought back to the lake-dwelling. If this were the case, would it not be permissible to suggest a taboo as the reason? The five domesticated animals of the neolithic period were represented in the lake-dwellings from the earliest times. Accordingly, the suggestion that domestic animals appear at different stages cannot be accepted. It is true that these five animals are not represented in equal abundance. At the beginning of the period of domestication, the goat and the sheep are much more rare than the ox, the dog, and the pig.

For a considerable time man continued to rely for his food-supply on wild animals, especially the stag; but the proportion of domestic animals rapidly becomes preponderant.

As regards their culinary tastes, the neolithic lake-dwellers seem to show a preference for certain of the domestic animals. The species of which they ate most abundantly were the ox and the pig; next come the dog (though it is not certain that the dog was eaten), the sheep, and the goat. What is the reason for this order of preference? Does it depend upon a special taste for any particular meat? Would they not in that case rear in large numbers only those species which they appreciated most?

The lake-dwellers in the stone age ate the domestic animals when they were full grown, except in the case of the pig. This animal was frequently eaten while it was young, and even when it was still a sucking pig. The ox and the goat were never eaten when quite young. The distinction was dictated, without doubt, by the desire to use the milk-giving qualities of the cow and the goat, and also, perhaps, the sheep, as long as possible, but this explanation does not affect the males of these species.

It thus appears that the exceptionally low water in the Swiss lakes in 1921 has not been without interest to science. Thanks to this phenomenon, some new and important facts have been recorded in the history of the culture of the neolithic lake-dwellers and, at the same time, of all the neolithic peoples.

## Vitamin Problems.<sup>1</sup>

By Prof. A. HARDEN, F.R.S.

THE existence of three vitamins, termed A, B, and C, has now been firmly established and a general idea has been obtained of their distribution among animal and vegetable organisms. Hitherto, comparatively little quantitative work has been done in this direction, and further progress must depend on a more general adoption of quantitative methods. These are at present tedious and not very accurate. In the case of each of the vitamins the requirements of the special animal employed serve as the unit of

comparison and these vary considerably from individual to individual, so that many observations are necessary if any, even moderate, degree of accuracy is to be attained. Thus in the estimation of the antiscorbutic potency of food materials, by the method worked out by Miss Chick and her colleagues at the Lister Institute, it has seldom been possible to achieve a greater accuracy than about 25-50 per cent. This obviously imposes a very serious limitation on any attempts to study variations in potency unless these are of a very gross order. Another great difficulty inherent in this kind of observation is that when the

<sup>1</sup> Abridged from a Discourse delivered at the Royal Institution on Friday, April 28.

potency is low, the necessary dose of the material to be tested is correspondingly high, and soon transcends what is permissible without interference with other necessary conditions of the diet, such as protein content, etc. Very much the same conditions hold with regard to Vitamin B, especially when this is estimated by the effect of the material on the growth of rats; and, as a matter of fact, the great bulk of the work carried out in America by this method is not strictly quantitative, but simply leads to the result that a certain ration does, or does not, suffice for the growth of a young rat.

As regards Vitamin A the method of Zilva and Miura promises to yield moderately accurate and consistent results. This is attained by keeping the experimental animals (young rats) on a diet totally deficient in Vitamin A until they have ceased to grow, and then ascertaining the minimum dose of the material to be tested which will induce definite and steady growth for four weeks. Animals which do not cease to grow in three weeks are rejected, greater uniformity in the results being thus attained. The test material is, whenever possible, administered quantitatively to the animal and not, as was formerly the practice, mixed with the ration in a known proportion. One of the immediate results of the application of this method has been the discovery that cod-liver oil, formerly classed with butter as a good source of Vitamin A, is in reality 200-250 times as potent as butter and is, along with similar fish-liver oils, by far the richest in this material of all the substances which have so far been examined.

A further piece of information, which is essential for the detailed study of these substances, is their behaviour towards heat, oxidation, etc. In this respect some progress has been made, and it may be stated with some confidence that both Vitamins A and C are moderately stable towards rise of temperature, provided that air be excluded, whereas in the presence of air they are rapidly inactivated. Whether the effect of air is reversible or not has not yet been ascertained. Vitamin B, on the other hand, appears not to be affected by air and is also moderately stable towards rise of temperature. None of the three vitamins is easily inactivated by hydrolysis under anaerobic conditions, and this fact has led to the interesting observation that Vitamin A, although usually associated, in the animal organism, with fat, is not itself a fat but remains in the unsaponifiable residue with almost unabated potency. This indicates how small a weight of the vitamin itself is necessary for the daily ration of a young rat. In some cases as little as 1.2 milligram of the oil is sufficient to permit of definite growth, and of this only 1.2 per cent. is unsaponifiable, while, as is well known, the chief constituent of the unsaponifiable matter is cholesterol, which has itself no vitaminic potency. The actual requirement of the vitamin itself must therefore be of the order of 1/500 milligram per diem. The other two vitamins have not been obtained in so concentrated a form, but it appears highly probable that they too are present in foodstuffs only in infinitesimal amounts.

The origin of all three vitamins is to be sought in the vegetable kingdom. The production of Vitamin

A has been followed (Coward and Drummond) from the seed, and it has been found that it does not appear until the photosynthetic processes begin. Thus sunflower seeds are almost devoid of it, and so are the etiolated seedlings formed when these seeds germinate in the dark. In the light, on the other hand, the green seedlings, grown in a medium free from the vitamin, produce it freely. This vitamin is often closely associated with the carotene and xanthophyll of plants; so intimately, indeed, that it was at one time thought that it might be closely related to, if not identical with, one of them. The association, however, although very frequent, is not essential, and no definite relation can be shown to exist between the two. Vitamin C is either absent from seeds or only present in them in very minute amount, but appears when the seed germinates and before any green parts are formed. Nothing is, however, known of the inactive pro-vitamin or of the process by which it is rendered active.

Concerning the origin of Vitamin B a considerable amount of discussion has taken place. Its presence in a large proportion in yeast points to the probability that it can be produced without the intervention of light, and both in America and in this country it has been found that yeast can actually produce the vitamin when grown in a "synthetic medium" comprising only substances of known composition and free from the vitamin in question. Recently, however, Eijkman, in Holland, has obtained a contrary result, so that this question remains at the moment open.

The animal organism appears to be unable, in normal circumstances, to produce any of these principles for itself, and hence the amounts found in animal products depend ultimately on the diet of the animal. This opens up, among many other problems, the important question of the vitaminic properties of milk, and there seems to be no doubt, from experimental work, both here and in America, that these properties are profoundly affected by the diet of the cow. Milk obtained in winter when the animals are stall-fed has been shown to be markedly deficient in Vitamin A, and there is also great danger of a deficiency of Vitamin C. One of the pressing requirements of the moment is the careful quantitative examination of foodstuffs available for the feeding of cattle, so that a rational system of winter feeding can be adopted which will produce milk as good as that given in summer. Such an examination would seem naturally to fall within the purview of the Board of Agriculture.

The evil results of a deficiency of Vitamins B and C, especially in the diet of children, are well known—beri-beri and scurvy, latent or patent—but the effect of a lack of Vitamin A is not so well recognised or so universally acknowledged. One school considers that a deficiency of this vitamin is at least a prominent factor in the causation, if not, as they formerly held, the sole cause of rickets. Others consider rickets to be a disease brought on by non-hygienic surroundings, lack of fresh air and exercise, etc. The latest experimental results show that rickets (in rats) can infallibly be produced by dietetic changes, but that the lack of Vitamin A does not of itself lead to the disease unless at the same time the diet is faulty as regards the supply of calcium or phosphorus. This faulty mineral supply

does not usually lead to true rickets if sufficient Vitamin A be present, although the bone formation under these circumstances is not quite normal. This explains the well-known curative effect of cod-liver oil in rickets. So marked is the effect of this remedy, that McCollum, not appreciating the relatively enormous concentration of Vitamin A present in it compared with that in butter, as proved by Zilva, has suggested that cod-liver oil contains some other specific substance absent from butter, to which its great superiority is due. The difference, however, seems to be merely quantitative, and the further complication suggested by McCollum appears to be unnecessary.

These experiments on rickets have led to what promises to be a discovery of far-reaching importance. Rats on a diet, which in the laboratory will infallibly

produce rickets, do not acquire the disease if they are exposed to sunlight in the open air or to ultra-violet radiation, and rats which have acquired the disease can be cured by either of these treatments, just as they can be cured by the administration of cod-liver oil. Sunlight and ultra-violet radiation have also been found to be effective cures or preventives of rickets in children. The cures by light and by cod-liver oil seem to proceed in precisely the same way, and the idea naturally suggests itself, especially to the mind of a chemist, that the light actually brings about the synthesis of the Vitamin in the animal body just as it does in the plant. This idea still awaits experimental verification or disproof; but there is no doubt that the discovery of this function of light will lead to profoundly important developments in our knowledge.

### Obituary.

PROF. W. GOWLAND, F.R.S.

PROF. WILLIAM GOWLAND died on June 10 in his eightieth year. He had originally intended to enter the medical profession and actually worked with a medical man in Sheffield for two or three years. Afterwards he became a student at the Royal College of Chemistry, from which he passed in 1868 to the Royal School of Mines. Two years later he obtained the associateship both in mining and metallurgy. He was awarded the Murchison medal in geology and the De La Beche medal in mining.

His first post was that of chemist and metallurgist to the Broughton Copper Company, Manchester. Two years later he went out to the Imperial Mint at Osaka, Japan, and held the post of chemist and metallurgist there for six years. During the next eleven years he acted as assayer, metallurgist, and chief of the foreign staff at Osaka, and was for some time adviser to the Imperial Arsenal. His work was of a decidedly varied nature, and he did much to introduce Western metallurgical and chemical methods into the departments with which he was associated. It was during this period that he acquired the knowledge of Japanese methods of extracting, refining, and working metals for which he afterwards became so famous. He carried out exploration work in Korea on behalf of the Japanese Government, in the course of which his expedition had some lively skirmishes with the natives.

As a young man Prof. Gowland was a keen oarsman, and was the first to introduce rowing into Japan. He had two modern "eights" built to encourage boat-racing among the staff of the mint, but they found these craft too unstable for their liking. Eventually they decided to choose their own boats and presented two for his inspection. He found they had selected a pair of "cutters" and had fitted each with port and starboard lights. He was also the first to initiate the Japanese into the use of the wheelbarrow. He had occasion to do this in connexion with some excavation work in the copper mint, and provided the labourers with barrows. The next morning he was astonished to find that the wheels had been removed and the sturdy Japanese were carrying the loaded wheelbarrows. On leaving Japan in 1889, the order of "Chevalier of the Imperial Order of the Rising Sun" was conferred

on him personally by H.I.M. the Emperor of Japan. During his residence there he gradually built up a very fine Japanese art collection, which included some valuable kakemonas.

Returning to England, Prof. Gowland acted as chief metallurgist to the Broughton Copper Company for some years, and in 1902 was appointed professor of metallurgy at the Royal School of Mines, in succession to the late Sir William Roberts-Austen. This post he held for seven years and retired in 1909.

So far as metallurgy is concerned, his chief interest lay in the non-ferrous metals, principally copper, silver, gold, lead, and their alloys. His knowledge, in particular, of the metallurgy of copper was unique, based as it was upon experience of the best methods in vogue, both in the East and West. In 1914 he published a textbook on the metallurgy of the non-ferrous metals which quickly became recognised as an authoritative work on the subject, and is now in its third edition. He also contributed various papers to the Institution of Mining and Metallurgy, the Chemical Society, and the Society of Chemical Industry. He was an original member of the Institute of Metals, its third president, and its first May lecturer. In 1907 he was elected president of the Institution of Mining and Metallurgy, and in 1909 was awarded the institution's gold medal.

There was, however, another side to his intellectual interests, as shown by his membership of the Society of Antiquaries, the Royal Anthropological Institute, and the Numismatic Society. His publications under these heads were numerous and varied, dealing with, *e.g.*, the early metallurgy of silver and lead, the remains of a Roman silver refinery at Silchester, the burial mounds and dolmens of the early Emperors of Japan, and silver in pre-historic and proto-historic times. From 1905 to 1907 he acted as president of the Royal Anthropological Institute.

Prof. Gowland was a man of great personal charm and distinction. He was extremely thorough in all he undertook, and never spared himself in the execution of his duty. His lectures were very carefully prepared and well delivered. The geniality of his disposition made him a general favourite with his colleagues and students, and he will always be affectionately remembered at the Royal School of Mines. H. C. H. C.



E. W. L. HOLT.

It is with deep regret that we record the death in London on June 10, at the age of fifty-seven, of Mr. Ernest William Lyons Holt, Chief Inspector of Irish Fisheries. Educated at Eton, where he won the Biological Prize, he entered the Army through Sandhurst and joined the Duke of Cornwall's Light Infantry, with whom he served in the Nile Campaign of 1884-5 and afterwards in the Burmah War 1886-7, during which his health broke down and he was invalided home.

Retiring from the Army, Holt took up the study of natural history, in which he had always been interested. His first zoological research was carried out at the St. Andrews Marine Laboratory, and resulted in a paper on the morphology of the brain of fishes, especially of the herring, which was communicated in 1890 to the Royal Society of London. In the same year he was appointed assistant-naturalist for the survey of fishing grounds on the west coast of Ireland, which was being carried out by the Royal Dublin Society. As the result of cruises carried out in 1890 and 1891 a valuable series of papers was published, the most important of which dealt with the eggs and larvæ of fishes, while in others the economic aspects of scientific fishery investigation were ably dealt with.

In 1892 Mr. Holt was appointed by the Marine Biological Association to take charge of a laboratory which was opened near Grimsby for the purpose of studying the fishery problems of the North Sea. Here for three years he successfully carried out investigations dealing with all aspects of fish life in their relation to commercial fisheries, paying special attention to the destruction of immature fish by trawling, a question which was thought at that time to be of the greatest practical importance. On leaving Grimsby, he spent some time in the south of France, where he resumed his studies on eggs and larval stages, publishing a finely illustrated memoir on this aspect of the natural history of Mediterranean fishes. Following this, three years were spent at the Plymouth Marine Laboratory, where he not only continued and extended his work on fishes, but took up the study of several groups of invertebrates which are largely used as food by fishes.

In 1900 Mr. Holt returned to Ireland, where he became scientific adviser to the fisheries branch of the

Department of Agriculture and Technical Instruction, succeeding the Rev. W. Spotswood Green as chief inspector of fisheries in 1914. Under his direction an important survey of the fishing grounds, especially to the west and south-west of Ireland, was organised and carried on for a number of years, the deep water of the Atlantic slope receiving a large share of attention. Mr. Holt gathered around him a brilliant staff of young naturalists, and an excellent series of reports was published. He continued to devote himself personally to the study of fishes, and included fresh-water fishes, especially the salmon, in his studies. His personal knowledge of fish life in all its aspects was probably greater than that of any other British naturalist, and at the same time he was a keen student of the literature of the subject. In his earlier years he had great facility as a draughtsman, and his papers were beautifully illustrated with his own drawings. He possessed an acute and critical intellect, a sound sense of proportion, and a quick eye for the things that really mattered in connexion with any question he took up. His work was greatly helped by a gift of rapid literary expression, accompanied by a quiet humour, which always made his writings interesting. His mind was essentially honest, he suffered from no illusions, and did his best to destroy what he thought were illusions in others.

E. J. A.

WE much regret to announce the death, on June 26, at the age of seventy-three years, of Albert, Prince of Monaco, well known for his oceanographical research work.

WE regret to see the announcement of the death, on June 22, of Sir Alexander M'Robert, at the age of sixty-eight years. After acting for a time as a lecturer in experimental physics and in chemistry, in Aberdeen, Sir Alexander went to India, where he passed the greater part of his life, closely associated with technical education. He was made a fellow of the University of Allahabad in the Faculty of Science, served on the committee of management of the Government Engineering College, Roorkee, and also as governor of the Agricultural College, Cawnpore. Sir Alexander had travelled extensively in many parts of the world, and received knighthood for his services in 1910, being created K.B.E. in 1919.

### Current Topics and Events.

THE Council of the Zoological Society of London has approved a scheme for the establishment of an aquarium at the Zoological Gardens in Regent's Park. The aquarium is to be built under the Mappin Terraces, but so installed as to be invisible from the front, and will not interfere with the panorama of the Terraces. It will consist of a crescentic gallery, 400 ft. long, lined with tanks on both sides. Those on the outer curve will have both daylight and electric illumination, while those on the inner curve will be lighted by electricity only, a method used at the Berlin Aquarium with complete success. The gallery will be divided into three parts—fresh water, marine, and tropical

aquaria—with special ponds for seals, diving birds, and trout. The tanks are to be constructed with the bottoms, sides, and backs of slate, and the fronts of polished plate glass set in a framework of white marble. They will be provided with rock-work arranged to suit the needs of their inhabitants. The water will be kept constantly circulating, flowing into the tanks from high-level reservoirs and thence through a series of underground filter-beds, on the plan of those in use at the New York Aquarium, to low-level reservoirs, from which it will be pumped by electric pumps to the high-level reservoirs again. Special arrangements are to be installed for heating

the tanks and for regulating the temperature of the water in the different aquaria. The plans for the gallery have been prepared by Messrs. Belcher and Joass, and the circulation, electric plant, and the heating, lighting, and ventilating systems have been designed by Sir Alexander Gibb. The scheme will cost about 50,000*l.*, and should provide London with the best-equipped and most carefully arranged aquarium in Europe.

A THIRD attempt to reach the summit of Mount Everest began on June 3. The monsoon being due to arrive early in June, it was clear that this must be the last attempt this season. The *Times* gives an account by Capt. Finch of his ascent with Capt. Bruce to 27,300 ft. in the previous attempt. The oxygen apparatus did not prove satisfactory and only one in ten was fit for use, but by reassembling the sound parts four serviceable sets were obtained. By the help of oxygen the climbers reached the North Col perfectly fresh and camped at 25,500 ft. A heavy gale with snow set in and lasted for two days, making progress impossible. When a start was made the Gurkha with the party collapsed and had to be sent back. Eventually, after five hours' diagonal climbing, Messrs. Finch and Bruce reached an altitude of 27,300 ft. The wind and cold were then so severe that they were compelled to turn, and reached No. 3 Camp thoroughly exhausted. A telegram from Jangkok, Sikkim, dated June 22, states that Dr. Longstaff, Major Morshead, Colonel Strutt, and Captain Finch have arrived there on their return from Tibet.

The growing interest in metallography is well illustrated by the establishment of the Metallografiska Institutet of Stockholm, the formal opening of which has recently taken place. The new Institute is under the direction of Dr. Carl Benedicks, whose work on the physical chemistry of metals is well known. An inaugural address was delivered by Prof. Arrhenius, who referred to the international character of scientific research, as shown by the presence of foreign representatives at the ceremony, and by the review of the history of metallography contained in the address of Dr. Benedicks. Beginning with the work of Sorby in Sheffield, and continued by many workers, among whom the French worker, Osmond, was prominent, metallographic research has always preserved an international character. It was announced that Sir Robert Hadfield, who has himself made many important contributions to this branch of study, had presented to the Institute an annual sum of 150*l.* for two years, to form a scholarship for a research worker, Englishmen having a preference. In his statement regarding this foundation, Sir Robert Hadfield directs attention to the remarkable contributions made by Sweden to chemistry, and especially to the chemistry of metals. The metals used in the manufacture of alloy steels, such as nickel, cobalt, tungsten, molybdenum, and vanadium, were discovered by Swedish chemists, while direct contributions to metallurgy have been made by many of their compatriots, from Swedenborg

and Bergman to Akerman and Brinell. The recent important work of Dr. Westgren on the space lattice of the allotropic modifications of iron, as determined by means of X-rays (*NATURE*, June 24, p. 817), is an addition to the record of which Sweden may be proud. It must not be forgotten, also, that the Sheffield steel industry owes its existence to the use of the pure Swedish irons obtained from native ores.

THE *Quest* arrived at Cape Town on June 18 from South Georgia *via* Tristan da Cunha and Gough Island. The *Times* announces that, in view of the low power and small size of the ship, it has been decided to abandon the proposed cruise in search of lost islands in the Southern Ocean and to return home. Landings were made at Tristan da Cunha, Inaccessible, Nightingale, and Gough Islands. At the last of these islands several days seem to have been spent ashore, during which some biological collections were made. The visit of the *Scotia* in 1904 showed that Gough Island has a most interesting fauna and flora, particularly worthy of study because the nearest land, with the exception of the Tristan da Cunha group, is South Africa, which is some 1500 miles distant. Details of the *Quest's* deep-sea soundings are not given, but they should be of great interest, since between South Georgia and Tristan da Cunha she traversed an area of the ocean in which practically no soundings have previously been taken.

News from Mr. Knud Rasmussen, published in the *Times*, gives some account of his work in Melville Peninsula and Fox Basin until the middle of last January. The autumn was spent around Lyon Inlet, which offered scope not only for biological work, but also for researches into Eskimo archaeology. During the winter, Mr. P. Freuchen was engaged in charting the western coast of Baffin Land against Fox Basin, which was imperfectly known. Mr. Rasmussen himself went south to Chesterfield Inlet near the mouth of Baffin Bay. To the west of this inlet two tribes of inland Eskimo are reported to live. This is of interest because all other tribes of Eskimo are coast dwellers. This autumn Messrs. Rasmussen and Freuchen hope to start on their long journey to the west across the Barren Lands through the area inhabited by the Kimpetu tribe, in an attempt to investigate the original routes of migration of the Eskimo, and to throw light on their origin.

DR. CHARLES D. WALCOTT, secretary of the Smithsonian Institution, has left Washington to continue his geological explorations in the Canadian Rocky Mountains. Dr. Walcott's work in previous seasons has done much towards clearing up the geological formations of this interesting region, and many thousands of fossil specimens have been brought back to add to the completeness of the exhibition and study series of the U.S. National Museum. One of the important results several years ago was the discovery of fossil bacteria in the pre-Cambrian rocks, probably the earliest form of life on the earth. The section to be studied this year will take in several localities north and south of the Bow Valley between

Banff and Lake Louise on the Canadian Pacific railroad. The particular problems to be attacked are connected with the growth of certain formations and the sequence of marine life in the rocks composing them. It is expected that many photographs of glaciers, mountains, and forests will be obtained.

At the meeting of the Royal Society of Edinburgh on June 19, the Keith Prize (1919-1921) was presented to Prof. R. A. Sampson for his astronomical researches, including the papers "Studies in Clocks and Time Keeping: No. 1, Theory of the Maintenance of Motion; No. 2, Tables of the Circular Equation," published in the Proceedings of the Society within the period of the award; and the Neill Prize (1919-1921) was presented to Sir Edward Sharpey Schafer, for his recent contributions to our knowledge of physiology, and in recognition of his published work, extending over a period of fifty years.

We have received an intimation that the Italian Royal Committee for Scientific Marine Investigations has assumed charge of the Zoological Station at Rovigno, Istria, which was formerly under German administration, and that the station is now in active work, with Prof. Raffaele Issel as Director.

THE second lecture of the series on physics in industry, arranged by the Institute of Physics, will be given on Tuesday, July 4, at 5.30 p.m., in the hall of the Institution of Electrical Engineers, Victoria Embankment, W.C.2, by Sir J. Alfred Ewing, whose subject will be "The Physicist in Engineering Practice, with Special Reference to Applications of Thermodynamics." The chair will be taken by Sir Charles A. Parsons, vice-president of the Institute.

THE fifth international Neo-Malthusian and Birth Control conference will be held in London on July 11-14, under the presidency of Dr. C. V. Drysdale. Many delegates from abroad are expected and the discussions have been arranged to take place in several sections. A visit to Dorling is arranged for July 15. This was the birthplace of the Rev. T. R. Malthus, author of the famous essay on the Principle of Population.

*The American Geologist*, which in 1905 was merged with *Economic Geology*, now resumes independence as *The Pan-American Geologist*. This monthly journal, devoted to speculative geology, constructive geological criticism, and geological record, is edited by Dr. Charles Keyes, Des Moines, Iowa. The associated editors are Edward W. Berry, Baltimore, Md.; Eliot Blackwelder, Cambridge, Mass.; Henry S. Washington, Washington, D.C.; and Gilbert D. Harris, Ithaca, N.Y. The first issue, volume xxxvii, No. 1, appeared in February last.

RECTANGULAR glass jars suitable for the exhibition of museum specimens were, before the war, generally obtained from Germany. Recently some attempt has been made to draw again on that source, but the difficulties remain considerable. For many years the Museums Association has sought to rouse British manufacturers to the desirability of meeting the ever

increasing need, but it is only now that any satisfactory result has been attained. We understand that there are at least two firms willing and able to meet the demand. The June number of the *Museums Journal* publishes a list of the sizes that can readily be made and asks curators to state their needs without delay. We regret to learn that Dr. Tattersall, the secretary of the Association, to whom this development is due, is at present ill, but letters may be addressed to the Secretary of the Museums Association, care of E. E. Lowe, The Museum, Leicester.

THE Journal of the Society of Glass Technology of May contains papers on the melting of glass, the action of analytical reagents on glass, methods used in determining the durability of glass, Zulkowski's theory of the relation between the composition and durability of glasses, and other subjects. It is clear from the contents of various issues of this journal which have been received that research on glass and matters relating thereto is proceeding in a very satisfactory manner, and the great improvements which must result from this scientific investigation may be expected to have a most beneficial effect on the British glass industry. It is satisfactory to note that the Journal is acquiring an international status, since one paper in the present issue comes from the Geophysical Laboratory of the Carnegie Institution of Washington, although many of the best papers owe their inception to the work of Prof. Turner, of the Department of Glass Technology of the University of Sheffield.

ON Wednesday June 7, a lecture was given by Prof. A. F. Holleman, of Amsterdam, at the Imperial College of Science and Technology, under the auspices of the University of London, entitled "Recent Researches on Substitution in the Benzene Nucleus." After a brief statement of the position of the subject at the time (1910) of the publication of his book, "Die direkte Einführung von Substituenten in den Benzolkern," Prof. Holleman dealt with the qualitative and quantitative investigations which have since been carried out in the laboratories at Amsterdam. Considering the matter in the light of his own and Boeseken's theory as to the mechanism of substitution (involving primary addition to one or other of the Kekulé double bonds), it was shown that in many complex instances the extent to which substituents enter the different positions can be predicted with fair accuracy from the general rules which have emerged from the experimental study of the simpler cases. Full emphasis was laid on the exceptions and unforeseen results. Indeed the whole discourse was highly critical and gave an illuminating insight into the methods by which, under Prof. Holleman's direction, the workers at Amsterdam are gradually reducing to ordered measure the whole chemistry of benzene substitution.

IN the editorial remarks in the opening pages of the Journal of the British Science Guild for May, attention is directed to a departure, namely, the inclusion of matter going beyond the actual records of the work of the Guild. No doubt the wider scope

thus afforded in emphasising the benefits of applied science will be appreciated by readers. Interesting light is shed on two incidents during the war—the Coronel sea-battle and the German advance in 1914—both illustrating the importance of accurate information regarding warfare on land and sea. Among other matters that are the subject of editorial comment may be mentioned "The Science of Sailing," "The Bases of Politics," and "The Need for a Scientific Missionary Journal." Much of the issue is naturally devoted to the annual report of the Guild and the annual meeting. Special interest attaches to the address of Sir Richard Gregory explaining the origin of the appeal to be conducted by Commdr. L. C. Bernacchi for funds to consolidate and extend the Guild's activities. Among other important steps may be mentioned the establishment of local branches of the Guild and the completion of the catalogue of scientific books, comprising over 6000 entries—in itself a remarkable piece of work that justifies the Guild's existence. A summary is given of Sir Leslie Mackenzie's address at the Edinburgh meeting of the British Association on "Science and Citizenship," and a tribute is paid to the memory of Sir Ernest Shackleton, whose passing away on the *Quest* at the commencement of this year will be fresh in the minds of readers, and whose achievements in the field of polar exploration will not soon be forgotten.

A NEW catalogue (No. 94) of second-hand works on Zoology, Botany, and Agriculture has been

issued by Messrs. Dulau & Co., Ltd., 34 Margaret Street, W.1. Among the 1400 volumes listed are two of especial interest, namely, a nearly complete set of *Curtis's Botanical Magazine*, formerly the property of Sir Joseph Hooker, with MS. corrections in nomenclature by Sir W. J. and Sir J. D. Hooker, and an unusual French Herbal, entitled "Recueil des plantes les plus usuelles peintes d'après Nature," in 12 vols. containing nearly 5000 illustrations drawn and coloured by hand, with manuscript descriptions.

MESSRS. W. HEFFER & SONS, Ltd., Cambridge, have just issued a list (No. 213) of some 600 works in new condition which they offer at greatly reduced prices. Many of the books listed deal with scientific subjects. The catalogue is obtainable from the publishers upon request.

A REPORT of the address given by Mr. F. W. Sanderston to the National Union of Scientific Workers, just before his death, is to be published shortly. Copies may be obtained from Maj. A. G. Church, General Secretary, 25 Victoria Street, S.W.1.

THE firm of Mr. T. Fisher Unwin, Ltd., 1 Adelphi Terrace, London, W.C.2, is arranging for the publication of the memoirs of Sir William Crookes, edited by Dr. Fournier d'Albe. Any letters and information likely to be useful to the editor will be gratefully received and carefully preserved and returned.

### Our Astronomical Column.

SKJELLERUP'S COMET, 1922 *b*.—This proves to be a short-period comet of the Jupiter comet-family. The following elliptical orbit has been derived from observations on May 20, 31, June 12, the third being by Dr. W. H. Steavenson at Norwood.

$$\begin{aligned} T &= 1922, \text{ May } 15, 0.0325 \text{ G.M.T.} \\ \omega &= 354^\circ 47' 20'' \\ \Omega &= 215^\circ 43' 31'' \\ l &= 17^\circ 23' 36'' \\ \phi &= 43^\circ 9' 00'' \end{aligned} \quad \left. \begin{array}{l} \\ \\ \\ \\ \end{array} \right\} 1922.0.$$

$$\log a = 0.44930.$$

$$\log q = 9.4904.$$

$$\text{Period} = 4.7201 \text{ years.}$$

These elements indicate a much closer approach to the earth than the parabolic elements did. Prof. Leuschner has pointed out that the comet is probably identical with 1902 II., discovered by Mr. John Grigg in New Zealand, and followed by him for 11 days. No one else saw it, and the observations were too rough to give a good orbit. If the period of less than 5 years is confirmed it will be the second shortest cometary period known, that of Encke, 3.3 years, being the shortest.

SOLAR ATMOSPHERIC CHANGES.—In the current number of the Monthly Notices of the Royal Astronomical Society (April) there are three communications relative to solar activity. The first is by Dr. William J. S. Lockyer, and deals with the relationship between solar prominences and the corona. In 1903 Dr. Lockyer published a paper on the same subject, concluding that the various forms of the corona, as photographed during eclipses, were dependent on the positions and intensities of the zones of

prominence activity. In the present paper, using quite independent prominence and corona data, the former extending over the period 1890–1920 and thus including three sunspot maxima and minima, he points out that the previous conclusion is well endorsed by these new observations. Mr. A. M. Newbigin publishes the results of his solar prominence observations for the year 1921 and gives curves showing mean areas and mean numbers. He shows that the main zones of prominences were situated in latitudes  $40^\circ$  N. and  $55^\circ$  S., and a much lesser zone of activity in latitudes  $20^\circ$  N. and  $25^\circ$  S. These zones are in conformity with the curves of latitudes of prominences illustrated in Dr. Lockyer's paper referred to above, the higher latitude zones being the commencement of a new zone of activity which will gradually move polewards.

Mr. C. P. Butler communicates a first paper on the systematic distribution of solar calcium flocculi, this contribution dealing with inclination of elongated groups. Several observers have previously shown that the mean inclinations of the axes of sunspot groups were found to vary from  $0^\circ$  to  $11^\circ$ , and that the amount of inclination increases with the solar latitude of the group. Mr. Butler has investigated the case of the areas of calcium flocculi as determined from measures taken from photographs secured with the spectroheliograph. He concludes that the inclinations range in general from  $0^\circ$  to  $40^\circ$ , with a few cases of specially high inclination. The range is therefore much greater than that found for spot-groups. In the above range there are maximum frequencies at certain latitudes, namely,  $15^\circ$ ,  $21^\circ$ , and  $28^\circ$ – $32^\circ$ . Other more detailed results are given.

## Research Items.

**PROBLEMS OF RACE AND NATIONALITY IN SOUTH AFRICA.**—The problems of race and nationality are discussed in the presidential address delivered before the South African Association for the Advancement of Science by the president, Dr. J. E. Duerden. He gives an instructive survey of the social condition of the Bantu races and of the European immigrants. The hereditary attributes of all the people of colour are markedly inferior to the white in all that pertains to the requirements of modern civilisation, and there is every reason to expect that they will remain so in the future, "for in considerations of this nature the teachings of zoology are overwhelmingly in favour of the unchangeableness of the germ plasm." He goes on to say that the Nordic race, represented by the English and Dutch, stands at the head of the human genus, and "it is in the daily competition with those that the Bantu, Indian, and Malay are to lead their lives. In the commingling of these races in South Africa there can be no question as to which will be dominant. In his hereditary endowments the white is far more gifted than the coloured, and must lead. Dominance, however, is not arrogance, nor does superiority necessarily carry with it harshness or unfairness."

**SECRET SOCIETIES IN THE SOUTHERN SUDAN.**—The spread of secret societies among the Sudanese is a question of some political importance, and the reports of several correspondents on the subject are summarised in *Sudan Notes and Records* (vol. iv. No. 4). The baneful influence of such associations has attracted the attention of the Government, which has recently revised "The Unlawful Societies' Ordinance" in order to bring them under control. The authorities emphasise their evil influence through terrorism, debauch, and robbery, and it is suggested that they are mainly the work of unscrupulous persons who exploit the fears of primitive man for their own nefarious ends. But, as is the case with similar organisations among tribes of the lower culture elsewhere, it is believed that the use of "fetish" or other magical objects in their rites implies a religious side to the practices of these societies which deserves to be more closely studied. It would be interesting to learn whether these cults are regarded as supplementary or antagonistic to the traditional beliefs and rites of the uninitiated members of the community, and whether their influence depends on the transitory prestige of some particular leader, or is deeply rooted in the official religion of the tribe.

**GEOLOGY OF MESOPOTAMIA.**—An interesting memoir just issued by the Geological Survey of India (Memoirs, vol. xlviii., 1922) embodies the results of Dr. E. H. Pascoe's reconnaissance of the part of Mesopotamia lying mainly to the east of the Tigris from about the latitude of Baghdad to that of the Great Zab river just below Mosul. Excluding the recent alluvium and the pleistocene conglomerates, the rock groups described are all of Tertiary age and fall naturally into two divisions:—(a) a lower, marine, gypsiferous series corresponding to a part of Dr. Pilgrim's Fars series of the Persian Gulf region; and (b) a younger fluviatile series, which is provisionally named the Kurd series and corresponds generally with the beds distinguished by Dr. Pilgrim as the Bakhtiyari series in Persia. The older, marine, gypsiferous beds were laid down in a relatively shallow gulf, which became silted up and finally gave place to fluviatile conditions after an intermediate stage of salt lagoons. Local erosion naturally occurred during this transition stage, but there is

no general or widespread unconformity dividing the marine from the later freshwater formations by which the former were covered. Folding of the sediments commenced in Fars times and became accentuated during the subsequent Kurd period, persisting into recent times; this is indicated by the marked steepening of the dips noticeable in passing from the upper to the lower series, while there is in general a marked contrast between the compressed condition of the anticlines and the open disposition of the alternating synclinal folds, which Dr. Pascoe ascribes to the circumstance that the rising antichinal saddles became eroded and consequently weakened, thus yielding more readily to compressional earth-movements. Petroleum is of outstanding importance among the minerals of economic value, and the conditions for its occurrence are so favourable that Dr. Pascoe regards Mesopotamia as a possible rival of Persia, outclassing Burma altogether in oil resources. Associated with the oil are small quantities of pitch and bitumen, while sulphuretted hydrogen is evolved in such large quantities that its recovery as a source of sulphur (or alternatively as sulphuric acid) is recommended as commercially feasible.

**AMERICAN CRETACEOUS DINOSAURS.**—The first of a series of preliminary notices on the Cretaceous dinosaurs, obtained in Alberta from 1910 to 1915 by parties sent out by the American Museum of Natural History under Mr. Barnum Brown, has been issued. The article in question, by W. D. Matthew and B. Brown (Bull. Amer. Mus. Nat. Hist., vol. xlv.), treats of "The family Deinodontidae." This family name was introduced by Cope in 1866, under what is now considered the more correct rendering for the Greek, as *Dinodontidae*, but the authors of the present brochure have altered it, presumably because the type genus, when founded by Leidy in 1856, was rendered, as then customary, as *Deinodon*. But if Leidy's original is to be scrupulously adhered to, why not Cope's? The authors discuss the group and give a most valuable "Chronological list of American Cretaceous Deinodonts and Ornithomids." Appended is a description of *Dromaeosaurus albertensis*, n. gen. et sp., from the Cretaceous of Alberta, and the conclusion is reached that it should be placed in a distinct subfamily, *Dromaeosaurinae*.

**ENTELODONTS FROM THE OLIGOCENE OF SOUTH DAKOTA.**—W. J. Sinclair describes the "Entelodonts from the Big Badlands of South Dakota in the Geological Museum of Princeton University" (Proc. Amer. Phil. Soc., vol. lx.), some of which had been previously inadequately determined, and had even figured in literature under other names. The new forms include two new species of Archaeotherium and *Scaphoehus altidens*, n. gen. et sp. The origin of the group as a whole is uncertain. Apart from the digging proclivities of *Scaphoehus*, one of the most clearly indicated "habits" of the entelodonts, according to the author, judging from lesions in the preserved remains, appears to have been their pugnacity; but surely the argument is equally allowable that the injuries were due to attacks by powerful enemies.

**PETROLEUM IN THE PHILIPPINES.**—In the *Philippine Journal of Science* of January last, Dr. Warren D. Smith gives a detailed account of his geological reconnaissance of the Pidatan Oilfield, Cotabato Province, Mindanao, the second largest island of the Philippine group. The occurrence of petroleum in the Philippine Islands has been known for some years, surface indications existing in Luzon, Mindoro,

Panay, Cebu, and Leyte; those of the Cotabato district in Mindanao, in particular the Pidatan seepage, are of more recent discovery, Pidatan not receiving detailed geological attention until the expedition of 1921, of which this paper is a report. The Pidatan field is about 60 kilometres north of Fort Pikit, Cotabato Province, the basin of the Rio Grande de Cotabato, practically in the centre of the island. The topography is mountainous and the country is exceedingly difficult. Geologically, the formations present consist principally of Tertiary limestones, sandstones, and shales pierced by basaltic and andesitic intrusions. The sediments are of recent, Pleistocene, Pliocene, and Miocene ages, many horizons yielding fossil evidence. The structures, however, appear to be very complex, owing to the regional earth movements and the igneous activity manifested. In fact, the faulting and folding has so disturbed the oilfield region that Dr. Smith does not hesitate to condemn the area from the economic point of view. On the other hand, the presence of the seepage and the nature of the oil involved at Pidatan suggest that petroleum certainly occurs in central Mindanao, possibly over an extensive region, and the advisability of intensive geological exploration over a wider area is clearly indicated. Analysis of the oil from the occurrence at Pidatan shows that it has a specific gravity of 0.9297 and is of paraffin base; no light fraction was obtained (under 150° C.), kerosene and heavy oil representing 45 per cent. and 49.5 per cent. of the sample respectively (by volume). Results of other tests indicate that the oil is much inspissated, as would be expected considering the geological circumstances, and is most suitable for use as a Diesel engine fuel. The author concludes his paper with a commendable caution to those controlling oil companies against belittling the value of sound geological work as a necessary preliminary to oil exploration; while not detracting from the value of the "practical" man's work, he makes it quite clear that success is achieved only where both driller and geologist work in harmony, a conclusion deserving of serious consideration by many of the would-be "wild-cat" oil explorers in our own colonies.

**THE GEOLOGY OF THE MOUNT EVEREST DISTRICT.**—The Mount Everest expedition of last year included among its staff Dr. A. M. Heron, who contributes to the *Geographical Journal* of June an account of his geological investigations, accompanied by a geological map. The mapping is virtually a westward continuation of Sir H. Hayden's investigations during the Tibet Expedition of 1903-4. Dr. Heron's task was one of unusual difficulty. Over much of the area examined his work had to proceed in advance of surveys, while the movements of the expedition were generally unfavourable to detailed work. Close and prolonged examination, moreover, was considered inadvisable, since it aroused the suspicions of the Tibetans. Dr. Heron claims that his work must be looked on only as a reconnaissance. The area examined covers more than 8000 square miles, and consists in the main of the Tibetan portion of the drainage area of the Arun river above Kharta. Two geological divisions can be recognised: a Tibetan area of sedimentary rocks which consists chiefly of east and west folds of Jurassic slates, and the crystalline Himalayan region to the south. The contrasts in topography clearly illustrate the differences in the underlying structure. On one hand are the somewhat tame rounded ranges, with broad valleys, of Tibet, and on the other the high, steep, and rugged Himalayas.

**RECOVERY OF SUGAR FROM BEET MOLASSES.**—Beet molasses is a substance of almost constant composi-

tion, containing 50 per cent. of sugar, 10 per cent. of ash, 15 per cent. of other organic substances, and 25 per cent. of water. The sugar cannot be separated from it by direct means, and among the methods employed for recovering the sugar is precipitation by one of the alkali earths. Until the present lime and strontia have chiefly been used. In the year 1838, however, Peligot found that baryta forms a very sparingly soluble saccharate. The use of baryta for the purpose of separating sugar was never carried out to any great extent for two reasons; (a) its cost, and (b) the poisonous nature of barium compounds. The cost of baryta should now be considerably reduced by the discovery of two French chemists, MM. Camille Degue and Paul Baud (*Comptes rendus*, May 1), who find that when barium carbonate is heated with silica at a temperature of 150°-200° C., and the mixture subsequently lixiviated with water, the carbonate is to the extent of more than 90 per cent. converted into hydroxide. This process should therefore render baryta available for the desaccharification of molasses. It is, however, very doubtful whether any Government will permit its use on account of the toxic character of traces of barium compounds.

**PYREX GLASS.**—The *Chemiker Zeitung* of May 25 contains an analysis of the "Pyrex glass" manufactured in America and used for cooking vessels. This glass is an astonishing resistant to changes of temperature, and may be used over an open fire. The chemical composition was found to be, in percentages: silica, 80.71; boric anhydride ( $B_2O_3$ ), 10.47; alumina, 3.55; lime, 0.70; magnesia, 0.57; soda ( $Na_2O$ ), 4.14. The low alkali content is noteworthy. Experiments showed that ordinary heating is not sufficient to melt the materials for such a glass, and special furnaces, possibly with surface-combustion heating, are assumed.

**SAFETY DEVICES IN WIRELESS EQUIPMENT.**—The American Bureau of Standards has given its approval to the recommendations of a committee of the National Fire Protection Association proposing the addition of some new safety rules to the National Electric Code relating to wireless telegraph installations. The proposed regulations provide for the protection of receiving and transmitting equipment against lightning effects, avoidance of risk of contact with neighbouring electric light and power circuits, and protection from effects of high potential surges in the lines supplying power to the equipment, as well as the ordinary requirements of sound construction. It is needless to detail all the proposals, but it may be remarked that, in the case of receiving equipments, a lightning arrester is required where the leading-in wire enters a building and, on account of the larger size of the ordinary transmitting aerial, which is more likely to be subject to damage from lightning, and the high voltages produced in the apparatus, the provision is recommended in transmitting stations of a double-throw switch for connecting the aerial either to the transmitting apparatus or to earth. The use of this switch makes it possible to disconnect the aerial entirely from the transmitting apparatus. On account also of the difficulty which has been experienced by the induction of voltages in the supply lines of a transmitting station, it is advisable to use a protective device across the power line near its point of entrance. It is noticeable that copper-clad steel wire is recommended throughout as an alternative to copper wire, owing to the fact that these two kinds of wire are practically equivalent in their conductivity for high-frequency current, while the former is stronger mechanically.

## Quantum Mechanism in the Atom.

AT a meeting of the Royal Society of Edinburgh on May 8 Prof. E. T. Whittaker read a paper on the quantum mechanism in the atom (since published in Proc. Roy. Soc. Edin., vol. xlii. pp. 129-142).

Prof. Whittaker shows that it is possible to explain quantum phenomena satisfactorily in terms of the classical electrodynamics without postulating any structure in the atom beyond that by which it is customary to explain induced magnetisation. The author considers the effect of an approaching electron in producing a "magnetic current" in the atom; up to a certain velocity of approach the electron does not get beyond the atom but suffers an "elastic impact" which repels it without loss of energy. When, however, the velocity of approach exceeds this critical value the electron passes through the magnetic atom and gives to it energy of exactly that amount or quantum which corresponds with the critical velocity. The transformation of this energy into radiant energy can be explained by generalising the conception; thus the magnetic current becomes equivalent to a charged condenser, partaking of the nature of a Hertzian oscillator. By a simple mathematical process, combined with the assumption that the oscillators in the atoms are similar to each other in structure and differ only in scale, the equation  $h\nu = U$  can be established, giving Planck's relation connecting the frequency,  $\nu$ , of the emitted radiation with the amount of kinetic energy,  $U$ , absorbed from the bombarding electron. A more definite form to the quantum mechanism is given by linking a conducting circuit with the magnetic structure. Photo-electric phenomena can be interpreted on the basis of this theory, and Bohr's theory of series-spectra likewise finds an explanation.

Sir Alfred Ewing suggested that instead of following Prof. Whittaker in leaving the magnetic atomic model at a certain point there is perhaps an advantage in not dropping the model, especially as it seems to give an immediate explanation of the manner in which oscillations are set up as the electron parts with its quantum of energy. In the Ewing magnetic model the central magnetic system or wheel is controlled by an outer system or ring. When an electron passes through and escapes it gives an impulse producing relative angular displacement of

inner wheel and outer ring, and the mutual magnetic forces tend to restore the original configuration. Oscillations are set up which expend their energy in emitted radiation. Conversely, in an atom in which oscillations are going on, an electron may be ejected (photo-electric effect). In being ejected it exerts an angular impulse which stops the oscillation and deprives the atom of the quantum of energy originally absorbed through resonance.

Dr. H. S. Allen directed attention to the fact that in Prof. Whittaker's "calamoids," or four-dimensional tubes of electromagnetic force, as well as in the Ewing magnetic model, magnetic forces rank on an equality with electrostatic forces. The number of magnetic tubes associated with Prof. Whittaker's magneton must be an integral number of times the unit quantum tube of magnetic induction. More satisfactory is a modified form of the quantum mechanism, in which two ring electrons are placed near together on the same axis, the electromagnetic force between them being repulsive. Such models cannot, in Dr. Allen's opinion, "reconcile" quantum dynamics with classical dynamics.

Dr. R. A. Houstoun suggested the advisability of testing Prof. Whittaker's theory by an appeal to numerical calculation, introducing, for example, definite values of the frequency and calculating the corresponding size of the molecule. The results appear to be satisfactory considering the simple nature of the assumptions made. It seems that the reciprocity which exists between electric and magnetic quantities in the electromagnetic wave must be extended to atomic structure.

Prof. Peddie remarked that the value of Prof. Whittaker's idea does not lie in its being an "only possible" one, for other possibilities exist. Its importance rests on the fact that the idea is a new one, giving for the first time an action on an electron which is not reversed in direction when the electron passes through an atom. A "perfectly elastic" collision seems to be attainable only by implicitly denying collisional radiation, which leaves part of the essential mechanism undescribed. The interactions of the atomic charges, ether and the "magnetic currents," may perhaps introduce difficulty regarding atomic subjection to the Newtonian first law of motion.

## The Second Royal Society Conversazione.

THE second conversazione of the Royal Society this year was held in the rooms of the Society at Burlington House on the evening of June 20, when the president, Sir Charles Sherrington, with Lady Sherrington, and the officers of the Society, received a large number of fellows and guests. Many interesting scientific instruments and specimens were shown, several of which were exhibited at the first conversazione held on May 17, and some were briefly described in NATURE of May 27, p. 693. Below are brief descriptions of other noteworthy exhibits.

Some selections from the contents of large pre-historic cooking-places at Buckenham, Tofts Park, Norfolk, were shown by Miss Nina F. Layard. The specimens were found by Miss Layard and Miss M. F. Outram in 1921-1922, and they include hearth-stones, heating-stones, bones and teeth of animals, fragments of pottery, flint flakes and implements. Mrs. Clayton exhibited a Roman bronze measure of capacity, made under Domitian, which was found during draining

works in the vicinity of the Roman Wall, three miles east of Gilsland, Northumberland.

A simple form of respiration meter was exhibited by Mr. H. F. Pierce. Two bellows are mounted on a vertical shaft, one of which measures the volume of inspired air, the other the volume of expired air. The latter is measured at a temperature of  $37.2^{\circ}$  C. to avoid error due to condensation of contained moisture. Respiration is recorded quantitatively upon a smoked drum. The moving parts are made very light and valves are operated electrically.

Mr. G. C. Robson had an exhibit showing that a highly differentiated character which appears discontinuously in the parthenogenetic gastropod, *Paludestrina jenkinsi*, does not reappear in two generations bred from parents showing this character. There is evidence that this character cannot be compared with an ordinary "fluctuating" variation. The Royal Botanic Gardens, Kew, showed a double coconut, or Coco de Mer, from the Seychelles, which

was germinating. The massive cotyledonary tube emerges from the nut, carrying the plumule and radicle out of the seed, and later the plumule pushes through the tube and grows up into the air. Specimens of the tubers of *Ecanda rubber* (*Raphionacme utilis*, Brown and Stapf) from Angola, which sometimes weigh as much as 15 lbs., and contain valuable rubber, were also shown.

Mr. W. Barlow exhibited some models of organic substances which are based on the law of valency-volumes and are in harmony with the Bragg structure found in the diamond. The valency-volume unit-cell appropriate for the carbon compounds is a rhombic-dodecahedron. The fundamental valency of carbon is expressed by a close tetrahedral group formed of four of the cells—that of nitrogen by three cells triangularly arranged, that of oxygen by two cells in face-contact, and that of hydrogen by a single cell. By fitting together appropriate numbers of these cells representing the composition and constitution of various compounds, structures can be made representing molecules which present internal symmetry closely corresponding with that of the crystal forms of these organic substances.

The Research Department, Woolwich, had an exhibit showing the time reaction in the colour change of Congo red in organic solvents. The change from red to blue which occurs during titration is associated with its flocculation from the colloidal condition and forms a time reaction related to the concentration of H ions and other properties of the solvent. There were also exhibits from the Air Ministry (Instru-

ment Section), among which was a radiator temperature outfit designed to determine the temperature distribution at different points on an aero-engine radiator and its connecting pipes. A six-junction thermocouple is used, and each set of junctions measures the temperature relative to that of the atmosphere. Another exhibit was a Filon aneroid dial for indicating to the pilot the height of an aeroplane above the ground. The scale is coiled into a spiral groove so that it can be adjusted to meet daily changes in temperature and barometric pressure. A metallic oxygen container was also shown in which a small quantity of silica-gel has been used successfully for cleaning up residual gases.

Mr. A. A. Campbell Swinton demonstrated the recording of wireless telegraphic messages. A short aerial on the roof of the building was connected through a tuner to a thermionic three valve amplifier, which in turn was connected to a 1 to 3 valve note magnifier. A moving coil siphon recorder was used, connected to the note-magnifier, either through a Brown relay, or through a very low frequency thermionic amplifier tuned to respond to the frequency of Morse signals. For the reception of continuous wave signals a separate thermionic heterodyne oscillator is employed which renders the high frequency signals audible by means of musical "beats." Dr. H. E. Hurst and Mr. D. A. Watt exhibited an interesting model, on a scale of 1:50, of the sluice of Aswan dam which is used for calibration purposes. The relation between  $Q$ , the discharge of the actual sluice, and  $q$  the discharge of the model is given very closely by  $Q/q = n \cdot 5/2$ , where  $n$  is the scale ratio.

### Psychical Monism.

THE Journal of the Washington Academy of Sciences of March 19 contains a communication from Mr. L. T. Troland of Harvard University entitled "Psychophysics as the Key to the Mysteries of Physics and Metaphysics." The article is interesting as a revival of the once famous theory of mind-stuff put forward by W. K. Clifford in his lecture on "The Nature of Things in Themselves." Mr. Troland connects it with several recent philosophical theories of psychical monism and brings it forward with particular reference to the consequences of adopting the principle of relativity and the quantum theory in physics, both of which, he contends, demand the recognition of the ultimate psychical nature of physical reality.

The essence of the mind-stuff theory is that it supposes mind to be constituted and articulated, not merely on the analogy of physical reality but on one and the same principle, so that a parallelism runs throughout the universe between mind and matter. Every electron or proton has not only a psychical aspect but in its ultimate nature is a constituent of mind, a bit of mind-stuff. Just as the unit of physics, the electric charge, enters into combination in atoms, molecules, and their more or less stable compounds, acquiring thereby the various

physical and chemical properties of things, so the mind-stuff combines to acquire the various sensational, emotional, and intellectual properties of personalities.

Mr. Troland's argument is interesting but scarcely convincing. He thinks by the theory to get over Berkeley's difficulty that no qualities of things, primary or secondary, are independent of the observing individual. The new realists, though they have recently attached Berkeley, have not, he thinks, succeeded as yet in developing an explanation of the universe which is either simple or plausible.

The difficulty of Mr. Troland's theory, however, if offered as a support of Einstein, would seem to be that it misses the essential difference between the activity of the observer co-ordinating events in space-time systems and the intersecting world-lines which present the events co-ordinated. The theory of knowledge we are waiting for in science as well as in philosophy is one which will give full meaning to the subjective and objective factors without sacrificing either to the other. Psychical monism seems to be no more successful than physical monism as a key to the mysteries of physics and metaphysics, but we commend Mr. Troland's argument, which includes in its scope recent physiological research as well as the new physical theories.

### Technical Education.

THE annual conference of the Association of Teachers in Technical Institutions was held on June 5-7 in London, and in the course of his presidential address, Mr. J. Paley Yorke claimed very strongly that technical education is definitely education and is as essential as any other branch of educational activity. He said that technical education is essentially scientific education, and urged

that the advance of scientific knowledge and the development of the applications of science to industry and manufacture have been so tremendous that the time has arrived when a special committee of inquiry should be appointed to investigate the whole field of technical education in relation to industry and to education generally. It is now forty years since there has been any national inquiry on technical



education, and during that time it has developed beyond the recognition of many of those who imagined themselves to be its guardians.

Mr. Paley Yorke protested against the charge of soullessness that is sometimes levelled at scientific education, and argued that it gives an extended vision and develops both imagination and that too rare gift of being able to marvel at the wonders of nature and to appreciate the beauties of life. It cannot be admitted that a good general education can be obtained only by the study of certain subjects in certain ways or that education and culture must be associated necessarily with bygone civilisations.

Reference was made to the fact that opportunity for contact with industry and for research is scant, and it was urged that directors of industry might submit some of their research problems to local Education Authorities and through them to the scientific and technical staffs of the various technical institutions in the area. It is realised, of course, that all problems would not arrive that way because of the publicity involved, but some useful work may be done.

Attention was also directed to the proposed reduction of grants for scientific research and to the reduction in the number of national scholarships for higher education. It was pointed out that not only do these reductions gravely imperil scientific and industrial development, but also that the percentage reduction in the estimates for these items is much greater than that for corresponding items in other branches of educational work.

Lord Burnham said that technical education is slowly gaining its right place in the assessment of national values. This country, with its superiority in industrial matters during the greater part of the nineteenth century, looked with supreme self-confidence upon the efforts of other nations to compete with us in industrial production. When the advance of scientific discovery showed that mere manual dexterity was not sufficient the necessity for technical education was admitted. Lord Burnham doubted whether there is any other class of teacher upon which the future prosperity of the nation depended so much. Technical teachers are striving to shape education for the public good and for the welfare of the generations which are coming to manhood.

Resolutions asking for the appointment of a committee of inquiry to investigate the whole field of technical education in relation to education generally and to industry, and expressing alarm at the reduction in the number and value of scholarships available for higher education, were carried unanimously.

### University and Educational Intelligence.

**BRISTOL.**—The J. S. Fry and Sons, Ltd., Colston Research Fellowship, which provides for payment of fees and a maintenance allowance of 150*l.* a year, has been awarded to Mr. F. B. Wrightson, a student in the Faculty of Engineering.

**CAMBRIDGE.**—Mr. W. B. R. King, fellow of Jesus College, has been elected to be fellow and lecturer in natural sciences at Magdalene College; Mr. P. M. S. Blackett to be Charles Kingsley Bye fellow of Magdalene College; Mr. L. E. Bayliss, Trinity College, to be Michael Foster student in physiology; Mr. F. Lavington and Mr. J. Line, to be fellows of Emmanuel College; and Mr. J. A. Carroll to be fellow of Sidney Sussex College.

**GLASGOW.**—Mr. A. D. Lindsay has been appointed to the chair of moral philosophy in succession to the

late Sir Henry Jones. Mr. Lindsay was formerly Shaw Fellow of the University of Edinburgh, and lecturer in philosophy at the old Victoria University. In 1906 he was elected Fellow of Balliol College, Oxford, and was appointed classical tutor and Jowett lecturer in philosophy.

**LEEDS.**—The Council has appointed Dr. W. T. David to be professor of civil and mechanical engineering in succession to Prof. J. Goodman, who retires in October next. Dr. David, who is at present professor of engineering at the University College of South Wales, was educated at Cardiff and Cambridge. He served as demonstrator in engineering under Prof. Bertram Hopkinson at Cambridge for two years, and later was appointed H.M. Inspector of Technical Colleges under the Board of Education. His research work has been concerned mostly with internal combustion engines.

The handsome gift received some little time ago from Col. Sir Edward Brotherton of 20,000*l.* has enabled the University to make an important development in the work of the department of pathology and bacteriology. Sir Edward's intention was that his gift should be devoted to the furtherance of the study of bacteriology with special reference to public health, and as a step in this direction the Council has instituted a new professorship to be called "The Sir Edward Brotherton Chair of Bacteriology." Dr. J. W. McLeod has been elected as the first holder of this chair. Dr. McLeod graduated with commendation at Glasgow University in the summer of 1908, and after acting as house physician at the Glasgow Royal Infirmary and house surgeon at the Glasgow Western Infirmary, gained the Coats research scholarship and worked for a year under Prof. R. Muir. Later he was appointed assistant lecturer and demonstrator in pathology at the Medical School of the Charing-Cross Hospital, and afterwards lecturer in bacteriology at the University of Leeds. Dr. McLeod has carried out important research work in the field of bacteriology, and has published numerous papers dealing more especially with the bacteriology of influenza, dysentery, pneumonia, and the streptococcal infections.

**LONDON.**—At a meeting of the Senate on June 21, Mr. H. J. Waring, Dean of the Faculty of Medicine and vice-president of St. Bartholomew's Hospital Medical College, was elected Vice-Chancellor for 1922-23, in succession to Sir Sydney Russell-Wells. A cordial vote of thanks was passed to Sir Sydney Russell-Wells for the services which he had rendered to the University as Vice-Chancellor since December 1919.

Mr. J. H. Woodger was appointed to the University readership in biology tenable at Middlesex Hospital Medical School. Mr. Woodger was educated at University College, whence he graduated in zoology, and was awarded the Derby Research Scholarship. In 1917 he was appointed protozoologist to the Central Clinical Laboratory in Amarah, and in 1919 assistant in zoology at University College.

Sir Charles W. C. Oman, Chichele professor of modern history in the University of Oxford, was appointed Creighton lecturer for the year 1922-23. The subject of his lecture will be "Historical Perspective."

The Lindley studentship for 1922, of the value of 120*l.* and tenable in the Physiological Laboratory, has been awarded to Miss M. J. Wilson-Smith of Royal Holloway College; and the University studentship in physiology for 1922-23, of the value of 50*l.* and tenable in the Physiological Laboratory of the University or of one of its Schools, to Miss M. M. A. Murray of Bedford College.

MANCHESTER.—Mr. E. D. Telford, lecturer in practical surgery in the University, and a member of the Honorary Staff of the Manchester Royal Infirmary, has been appointed professor of systematic surgery.

By the will of the late Sir William Lorimer, who died on April 9 last, the Court of the University of Glasgow will receive the sum of 10,000*l.*

It is announced in *Science* that, by the will of the late Amos F. Eno, Columbia University, New York, will receive a bequest of about four million dollars.

THE Beane Scholarship in *Materia Medica* at Guy's Hospital Medical School is vacant. It is of the yearly value of about 50*l.* and tenable for three years. It is open to candidates who have received at least part of their medical education at Guy's Hospital. The latest date for receiving applications is July 7. They should be sent to the Dean of the School, S.E.1.

THE Gull studentship in pathology and allied subjects, of the annual value of about 250*l.* and tenable for three years, is being offered by Guy's Hospital Medical School. The studentship is open to candidates under 35 years of age who have studied in the school. Applications must reach the Secretary to the Board of Electors, Guy's Hospital Medical School, S.E.1, by, at latest, July 7.

THE summer meeting of the Association of Technical Institutions will be held at Oxford on Friday and Saturday, July 7 and 8. The sessions on Friday and Saturday mornings will commence at 10.30 o'clock, when the president, The Right Hon. Walter Runciman, will occupy the chair. The Rev. L. R. Phelps, Provost of Oriol College and Pro-Vice-Chancellor, will welcome, on behalf of the University, the members of the association at the opening of the conference. Papers will be read by Rev. W. Hardy Harwood (Chairman of the Council) and Principal J. F. Hudson (Huddersfield) on "The Relation of Technical Education to the Question of General Education." Principal J. Quick, on "Central Schools and their part in the Preparation of Scholars for Higher Technical and Junior Technical Schools," and by Mr. E. C. Kyte, Secretary of the Library Association, on "Technical Libraries—How to Start and Develop them."

THE annual report of the Livesey Professor, Prof. John W. Cobb, at the University of Leeds, gives an account of the work done in the department of coal gas and fuel industries (with metallurgy) for the session 1920-21. The number of students (41) reached the highest figure in the history of the department; one third (14) taking the fuel and metallurgy course, the remainder (27) the course in fuel and gas engineering. The special evening classes included courses on the distribution of gas (Mr. Walter Hole), coke oven practice (Mr. W. Greaves), steaming in vertical retorts (Dr. A. Parker), and metallurgy (Mr. P. F. Summers). These courses were attended by 49 external students in addition to the full-time registered students. Researches were carried out on the liberation of nitrogen from coal and coke as ammonia, the structures of cokes prepared at different temperatures, the losses of ammonia in coke oven practice, a laboratory apparatus for coal distillation, the expansion of refractory materials, the trustworthiness of recording gas calorimeters, and the efficiency of production of blue water gas. The endowment funds of the department have benefited by substantial donations from the South Metropolitan Gas Company, the South Suburban Gas Company, and from Mr. A. G. Glasgow.

## Societies and Academies.

LONDON.

**Royal Society, June 15.**—Sir Charles Sherrington, president, in the chair.—H. M. Evans: The defensive spines of fishes, living and fossil, and the glandular construction in connexion therewith, and observations on the nature of fish venoms. The gland in the groove of the spine of the sting-ray (*Trygon pastinaca*) consists of two portions—the deepest part of the groove contains an alveolar-connective tissue structure, which is separated from the true glandular epithelium by a pigmented capillary layer. The dorsal fin-spines of the spiny dog-fish *Acanthias* are grooved, and the groove is occupied by a gland with definite follicles. *Cestracion* also has a well-developed gland at the base of the dorsal fin spines. The spines of *Chimæra* and of the *Pleuracanthidæ* show structures which suggest a specialised function. The nature and properties of Weever venom are described; the filtration of venom profoundly affects its hemolytic properties. Experiments are described on the native use of abrin as an antidote to fish venoms.—D. W. Cutler, L. M. Crump, and H. Sandon: A quantitative investigation of the bacterial and protozoan population of the soil: with an account of the protozoan fauna. The results of 365 consecutive daily counts of the numbers of bacteria and of six species of protozoa in a natural field soil are given. Large fluctuations occur which cannot be correlated with meteorological conditions. Fourteen-day averages of the daily numbers show marked seasonal changes superimposed on the daily variations in numbers. In general, both bacteria and protozoa are most abundant at the end of November, and fewest during February. The changes are not directly influenced by temperature or rainfall. An inverse relationship is found between the numbers of bacteria and certain amœbæ, and a two-day periodicity obtains for the numbers of the flagellate *Oicomonas termo* which are active.—D. W. Devanesen: The development of the calcareous parts of the lantern of Aristotle in *Echinus miliaris*. All the calcareous elements of the lantern of Aristotle, with the exception of the teeth, are deposited as triradiate spicules. A "compass" arises from two rudimentary spicules. It is the only element of the lantern absent in the "echinus-rudiment." A tooth is a paired structure in consequence of its composition of a double row of lamellæ. A pair of lamellæ is its ultimate unit. A remarkable stage in the consolidation of these lamellæ is the cone-in-cone arrangement. The carina is formed by the beaks of the serially fitting cones. The ossicles of the lantern are compared with those of the mouth-frame of star-fish.—A. Lipschütz, C. Wagner, R. Tamm, and F. Bormann: Further experimental investigations on the hypertrophy of the sexual glands.

**Zoological Society, June 13.**—Prof. E. W. MacBride, vice-president, in the chair.—Miss J. B. Procter: A study of the remarkable tortoise *Testudo loveridgii* Blgr., and the morphology of the Chelonian carapace.—J. T. Carter: A microscopical examination of the teeth of the primates.—H. G. Jackson: A revision of the isopod genus *Ligia*, Fabricius.—W. R. B. Oliver: A review of the Cetacea of the New Zealand seas.—F. Wood Jones: On the dental characters of certain Australian rats.

**Linnean Society, June 15.**—Dr. A. Smith Woodward, president, in the chair.—A. B. Rendle: Seedlings of horse-chestnut from which the terminal bud had been removed by cutting through the epicotyledonary stem. Minute buds appeared on the cut surface corresponding in position with the cambium-

layer in the stem. A new shoot was also produced in the axil of each of the cotyledons.—Sir Arthur Shipley: *Furia infernalis*. Linnaeus was probably stung by a virulent insect which may have conveyed to his system some pathogenic germs unknown at that time.—T. A. Sprague: The identification of *Sison Ammi*, Linn. *Sison Ammi* is an umbelliferous plant published by Linnaeus in the first edition of the "Species Plantarum" in 1753. The type-specimens in the Linnean Herbarium and the British Museum show that it is *Carum copticum*, a medicinal plant which yields the Ajowan seeds and Ajowan oil, from which thymol is obtained. The history of the drug Ammi goes back to Dioscorides, who lived in the first century of the Christian era; he described it as having a minute seed with the flavour of marjoram. Various plants have been described as the Ammi, but in the plates of Umbelliferae published by Rivinius at the end of the seventeenth century, the official Ammi is *Carum copticum*. The geographical source of the drug supports this conclusion. The best quality of Ammi was imported from Alexandria, but was actually grown in Arabia, where *Carum copticum* is still cultivated. It has never been found in a wild state.—E. A. Newell Arber: Critical studies of coal-measure plant impressions. The British Upper Carboniferous species of the genus *Lepidostrobos*, Brongn., preserved as incrustations, and other impressions were discussed.—J. Burr-Davy: A revision of the South African species of *Dianthus*. Thunberg's specimen of *D. incurvus*, Thunb., does not match any South African material at Kew or the British Museum. Thunberg himself identifies it on the sheet with *D. albens*, Ait., but the specimen does not agree with the type of *D. albens* in the British Museum. In the "Flora Capensis," Sonder recognised nine species of *Dianthus*. Of these, seven only are valid, and to them must be added four species not recognised by Sonder. Six additional species and three varieties are now described, bringing the total number up to seventeen species and three varieties.

Royal Meteorological Society, June 21.—Dr. C. Chree, president, in the chair.—J. E. Clark, H. B. Adames, and I. D. Margary: Report on the phenological observations for the year 1921. After mid-December the mildness until late March was extreme, which gave premature fruit blossom and its usual concomitant of poor fruit crops, except apples. The four early spring flowers were more than 18 days earlier than the 30 years' mean; April and May, 14 days, June, 10, and July, 6 days. Grain-cutting was very early. The warm uprush along the Bristol Channel, and up the Severn and Dee valleys to include the Wirral Peninsula, was almost identical with the isothermal trend and values for 1920. In the north-east of Norfolk there was a recurrence of the cold area so well marked in the years 1919 and 1920, spreading southward from the North Sea, and curving south-eastward by Norwich to include Bungay, and also of the long tongue stretching from the Scottish border southward to include Leicestershire and Rutland. The northerly bulge of warmth just north of the Isle of Wight was again very definite. High ground is, as before, indicated on the maps by relatively late isothermal areas. Among exceptional effects were the brief blooming period of the summer flowers and the earliness of the autumn flowers, especially the Michaelmas daisies; the dormant or destroyed seed-sowing experiences; the frequency of second blossom after the August rains, typically the horse-chestnut; the early departure of the swallows; the dearth of tortoiseshell and allied butterflies, apparently from lack of nettles. October had a week of unparalleled heat, while November opened with severe frosts.

After a partial fall in late July, trees had retained their foliage to an unusually late date, and those frosts had the effect of making many of the leaves brown and shrivelled as if from excess of heat. Planes and elms kept their green leaves almost or quite until December.—L. F. Richardson, A. Wagner, and R. Dietzius: An observational test of the geostrophic approximation in the stratosphere. Wind velocity, at points not too near the earth's surface or the equator, may be found with an accuracy of about 5 per cent. from the horizontal pressure gradient and the rotation of the earth. A test of the error involved in neglecting other considerations is obtained by inserting the "geostrophic" velocities in the equation for the accumulation of mass. Thus a theoretical equality, valid in the stratosphere, between certain derivatives of wind and temperature is obtained. From observations collected by Wagner and Dietzius, the quantities which this theory makes equal have a positive correlation of about four-tenths.

## EDINBURGH.

Royal Society, May 8.—Prof. W. Peddie, vice-president, in the chair.—Prof. E. T. Whittaker: The quantum mechanism in the atom (see p. 23).—A. R. Forsyth: Differential invariants and other concomitants of quadratic differential forms in four variables. The method is that of Lie's continuous groups, and is thus entirely different from the Christoffel method usually expounded. It provides new results which the Christoffel method did not even suggest. It can be applied to obtain Einstein's critical form in the relativity theory of gravitation; on one hand, some of his conditions were covered by others, and on the other hand his form satisfied one equation more than the set he initially postulated.—T. R. MacRobert: The asymptotic expansion of the confluent hypergeometric function, and the Fourier-Bessel expansion.

## PARIS.

Academy of Sciences, June 6.—M. Emile Bertin in the chair.—Ch. Boulanger and G. Urbain: The composition and chemical characters of thortveitite from Madagascar. Five complete analyses of this mineral are given. The proportion of yttrium earths does not exceed 0.5 per cent., while the Norwegian mineral contains 4.18 per cent. Of this group only yttrium, neoytterbium, and lutecium could be detected.—MM. d'Arsonval, Bordas, and Touplain: Study of the glacier waters of Argentière and Bossons. There are marked differences in the electrical conductivity and chemical composition of the waters from these two sources.—Carl Stormer: Determination of the external magnetic field of the sun by the structure of the solar corona and the constants of the aurora borealis.—Louis Roy: Electromagnetic actions in an isotropic system.—G. Reboul: A new radiation and its application to the study of the ultraviolet of Millikan and Lyman.—A. Tian: Thermostats with multiple jackets. The copper vessel containing the liquid to be maintained at a constant temperature, is surrounded with felt and placed in one or more boxes, also of copper, which are isolated in the same manner. The external jacket is heated, and a uniform, steady temperature can be thus maintained without stirring. The advantages claimed for this system are that the thermal oscillations due to the regulator are almost entirely eliminated. The temperature of the inside bath is practically independent of variations in the room temperature, and stirring is not required.—Léon and Eugène Bloch: Spark spectra in water.

The photography of spectra of sparks under water, by the automatic separation into arc lines and spark lines and by the differences in the appearance of the lines, appears to be valuable in detecting spectral regularities.—M. de Bellescize: Damping the oscillations of resonators in wireless telegraphy.—A. Recoura: Some new properties of the green sulphate of chromium. Green sulphate of chromium forms complex compounds with potassium sulphate, and the resulting solutions give reactions with benzidine compounds or with barium chloride, indicating that  $SO_4$  ions are absent or present in small proportions only. Results are given of a study of the effects of temperature, dilution, and time on these complexes.—Paul Riou: The velocity of absorption of carbon dioxide by alkaline solutions.—Mlle. Wurmser: The preparation of ammonium nitrate. An extension of earlier work by M. Rengade on the formation of ammonium nitrate by the interaction of sodium nitrate and ammonium chloride.—Mlle. N. Wolf: Furfural- $\alpha$ -methylcyclohexanone and some of its derivatives. Mono- and difurfuralcyclohexanones.—E. Berger: A formal lamp. A detailed account, with diagrams, of the construction of a new lamp for burning methyl alcohol to formaldehyde. With copper oxide as a catalyst the yield is 25-30 per cent, with silvered asbestos, 35-45 per cent. of the alcohol used is obtained as formaldehyde. Results of the application of the lamp to practical disinfection of rooms are given.—H. Joly: The tectonic direction of the Cretaceous and Tertiary deposits in the neighbourhood of Haro (Logroño, Spain).—P. Lory: The glacial stages and a valley recording these stages (Bédat, Chaine de Belledonne).—P. L. Mercanton: The glacial system of the Beerenberg of Jan Mayen. This extinct volcano was climbed by the author, with J. M. Wordie and T. Lethbridge, in August 1921. From the highest point (about 2500 metres) the structure of the crater was made out, and a detailed account of this and the glacier system is given.—MM. Pons and Rémy: The reddish-brown coloration shown in March 1922 by the Briançon snow. Specimens of the coloured snow, collected on March 19 at an altitude of 2350 metres, were examined, after melting, chemically and microscopically. There was practically no organic matter, and the microscope showed no remains of microscopic organisms (Algæ, Foraminifera, diatoms), nor were there any vitreous inclusions characteristic of volcanic dust. Chemical analysis showed silica, iron, and alumina. The possible origin of the dust is discussed, but no definite conclusion could be arrived at.—P. Bugnon: The fibrovascular organisation in Mercurialis. Possible descent from a primitive form.—Gustave Chauveaud: The principal variations in the vascular development of the first phyllorhiza of Phanerogams are not determined by intercalary increase.—Louis Lapicque: Mechanism of the exchanges between the cell and the surrounding medium. The osmotic pressure in the cells of marine Algæ is higher than that of sea water. This is incompatible with the currently accepted view that all exchanges of the cells are determined by the laws of osmosis. The author holds that, on the contrary, the exchanges of the cells are the result of physiological work and that diffusion and osmotic pressure intervene often as resistances only.—Paul Portier and Marcel Duval: The variation of the osmotic pressure of the blood of the cartilaginous fishes under the influence of modification of the salinity of the surrounding sea water. The dog-fish was used in these experiments, and it was found that the osmotic pressure of the blood was not equal to that of the sea water in which the fish is immersed. There was a tendency for the osmotic pressure of the blood to follow that of the sea water, but the

adjustment was very imperfect. The fish supported dilution of sea water better than enrichment with salt.—E. Fauré-Fremiet and Mlle. H. Garrault: Constitution of the ovarian egg of the carp (*Cyprinus Carpio*).—H. Vallée and H. Carré: The plurality of the alpthous virus.

## BRUSSELS.

Royal Academy of Sciences, June 3.—M. A. Lameere in the chair.—F. Swarts: On trifluoromethylcyclohexane.—F. Swarts: On trifluoroacetylacide.—Th. De Donder: The electromagnetic field and the gravific field.—A. Mélant: The conditions determining the encystment of the infusorian, *Euploetes harpa*.—M. Philippson: A new form of electrical resistance of electrolytes.—M. Nuyens: A change in the variables of M. De Donder.—P. Bruylants and J. Deneyne: The determination of the atomic weight of selenium.

## Official Publications Received.

The Mellon Institute of Industrial Research of the University of Pittsburgh. Ninth Annual Report on the Industrial Fellowships of the Mellon Institute for the Institute's Fiscal Year, March 1, 1921, to March 1, 1922. Pp. vi+23. (Pittsburgh, Pa.)

South Australia: Department of Mines. Mining Review for the Half-Year ended December 31st, 1921. Compiled by Lionel C. E. Gee. No. 35. Pp. 72. (Adelaide.)

South Australia: Department of Mines: Geological Survey of South Australia. Bulletin No. 9: The Iron-Ore Resources of South Australia. By R. Lockhart Jack. Pp. 71. (Adelaide.)

Bureau of Education, India. Occasional Reports No. 10: Adult Education (University Extra-Mural Teaching in England and Wales). By J. P. Bulkeley. Pp. ix+98. (Calcutta: Government Printing Office.) 8 annas.

Bureau of Education, India. Indian Education in 1920-21. Pp. ii+87. (Calcutta: Government Printing Office.) 1.8 rupees.

Technical College, Bradford: Diploma and Special Day Courses. Prospectus, Session 1922-23. Pp. 168+plates. (Bradford.)

Report of the Fifteenth Meeting of the Australasian Association for the Advancement of Science. Hobart Meeting, held in Melbourne, January 1921. Edited by Dr. Georgina Sweet and Dr. A. C. D. Rivett. Pp. lxxxix+350. (Sydney, N.S.W.: The Association, Elizabeth Street.)

## Diary of Societies.

## FRIDAY, JUNE 30.

ASSOCIATION OF ECONOMIC BIOLOGISTS (at the Royal Horticultural Society's Gardens, Wisley), leaving London 11.15-11.30 A.M.—Annual Field Meeting.

ROYAL SOCIETY OF MEDICINE (Laryngology Section), at 4.45.

## MONDAY, JULY 3.

VICTORIA INSTITUTE (at Central Buildings, Westminster), at 4.30.—Right Rev. Bishop, Weldon: Diploma. (Annual Address.)

FELLOWSHIP OF MEDICINE (at Royal Society of Medicine), at 5.—Dr. J. S. Goodall: So-called Functional Diseases of the Heart.

ROYAL INSTITUTION OF GREAT BRITAIN, at 5.—General Meeting.

ROYAL INSTITUTE OF BRITISH ARCHITECTS, at 8.—Dr. T. Ashby: Recent Excavations at Rome.

ARISTOTELIAN SOCIETY (at University of London Club, 21 Gower Street), at 8.—W. O. Brigstocke: Probability.

## TUESDAY, JULY 4.

ETGENICS EDUCATION SOCIETY (Annual General Meeting) (at Royal Society), at 5.30.—Dr. Tredgold, Dr. C. H. Bond, Dr. B. Hollander, R. A. Fisher, and others: Conference on the Inheritance of Mental Qualities, Good and Bad.

INSTITUTE OF PHYSICS (at Institution of Electrical Engineers), at 5.30.—Sir Alfred Ewing: The Physicist in Engineering Practice, with Special Reference to Applications of Thermodynamics. (Lectures on "Physics in Industry" (2).)

SOCIOLOGICAL SOCIETY (at Leplay House, 65 Belgrave Road), at 8.15.—S. C. Ramsey: Regional and Vocational Influences on Architecture.

## WEDNESDAY, JULY 5.

ROYAL METEOROLOGICAL SOCIETY (a Summer Meeting) (at the Croydon Aerodrome), at 3.45.—Address on the Arrangements for supplying Meteorological Information to Pilots.—Inspection of Aerodrome, etc.

## THURSDAY, JULY 6.

ROYAL SOCIETY OF MEDICINE, at 5.—Annual General Meeting.

CIVIC EDUCATION LEAGUE (at Leplay House, 65 Belgrave Road), at 8.15.—A. Farquharson: Art as a Mirror of Society.

# NATURE

A WEEKLY ILLUSTRATED JOURNAL OF SCIENCE.

*"To the solid ground  
Of Nature trusts the mind which builds for aye."*—WORDSWORTH.

No. 2740, VOL. 110]

SATURDAY, JULY 8, 1922

[PRICE ONE SHILLING

Registered as a Newspaper at the General Post Office.]

[All Rights Reserved.]

## BALANCES & WEIGHTS

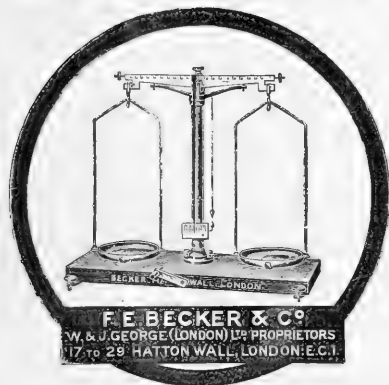

## REYNOLDS & BRANSON, LTD.

Chemical Glassware, Chemical and Physical Apparatus Makers to His Majesty's Government (Home and Overseas Dominions), Laboratory Outfitters, &c.

Gold Medals at Allahabad and London. Grand Prix and Gold Medal at the International Exhibition, Turin.

### STROUD & RENDELL SCIENCE LANTERN.

The "University" Lantern,

with Russian iron body, sliding baseboard, two superior objectives, with rack and pinion for focusing, condensers  $\frac{1}{4}$  in. diam., plane silvered mirror "A," which is moved by a knob causing the rays to be reflected upwards for the projection of objects in a horizontal plane silvered prism which can be used at "C," or as an erecting prism in mount "D," limelight

burner or arc lamp, slide carrier, complete in travelling case, with reversible adjustable stage for supporting apparatus.

PRICE ON APPLICATION.

CATALOGUES (Post free).

Optical Lanterns and Accessory Apparatus  
Chemical Apparatus and Chemicals, etc., etc.

14 COMMERCIAL STREET, LEEDS.

## SPECTROMETERS

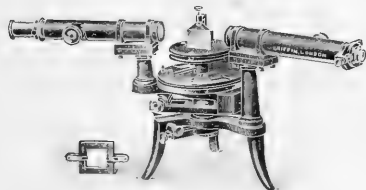

Particulars and Prices on application to—

JOHN J. GRIFFIN & SONS, LTD.

Kemble Street, Kingsway,  
London, W.C.2.

## HOLIDAY BINOCULARS

We have over 40 different Prism models, and many second-hand patterns in stock. Ask for price list "B.N.," or for a selection on approval.

NEGRETTI & ZAMBRA  
38, HOLBORN VIADUCT, E.C.1.  
LONDON.

**UNIVERSITY OF LONDON.**

The Semon Lecture entitled "THE DEVELOPMENT OF TRANS-ATLANTIC RHINO-LARYNGOLOGY" will be delivered by Professor H. S. BIRKETT, C.B., M.D. (Dean of the Faculty of Medicine, McGill University, Montreal) at the Rooms of the ROYAL SOCIETY OF MEDICINE, 1 WIMPOLE STREET, W.1, on WEDNESDAY, JULY 12, 1922, at 5 P.M. The Chair will be taken by the Vice-Chancellor of the University (Mr. HOLBERT J. WARING, M.S., F.R.C.S.). ADMISSION FREE, WITH-OUT TICKET.

EDWIN DELLER, Academic Registrar.

**NATIONAL UNION OF SCIENTIFIC WORKERS.**

25 VICTORIA STREET, WESTMINSTER, S.W.1.

The main object of the Union is to secure in the interests of national efficiency that all scientific workers are given the fullest opportunity of working up to the limit of their capacity in the service of the community.

There are now eighteen branches of the Union. They include those formed by:

- (i) University Scientific Staffs and Research Workers and Scientific Staffs in other teaching institutions;
- (ii) Government Scientific and Technical Staffs;
- (iii) Scientific workers in Industry.

The General Secretary of the Union will be pleased to arrange for members of the Executive to address meetings of industrial, Government departmental, or university scientific workers, on the work of the Union.

A list of members and the Annual Report for the year 1920-21 will be sent on application to

THE GENERAL SECRETARY,

at the above address.

**UNIVERSITY COLLEGE OF SWANSEA.**

(A CONSTITUENT COLLEGE OF THE UNIVERSITY OF WALES.)

Principal—T. FRANKLIN SIBLY, D.Sc., F.G.S.

The Third Session will open on October 5, 1922.

(a) Degrees of study are provided for:

(i) Degrees of the University of Wales in Arts, in Pure Science, and in Applied Science (Metallurgy and Engineering);

(ii) Diplomas of the College in Metallurgy and in Engineering;

(iii) The training of Teachers for Elementary and Secondary Schools;

(iv) The first Medical Examination of the University of Wales and of other Examining Bodies.

Persons who are not desirous of studying for degrees or diplomas may attend selected College Classes, provided they satisfy the Authorities of the College that they are qualified to benefit by such classes.

Entrance Scholarships will be offered for competition in September 1922. Particulars concerning admission to the College, and of the Entrance Scholarships, may be obtained from the under-signed.

EDWIN DREW, Registrar.

University College,  
Singleton Park, Swansea.

**FINSBURY TECHNICAL COLLEGE.**

LEONARD STREET, CITY ROAD, E.C.2.

Dean for the Session, 1921-22:

Professor W. H. ECCLES, D.Sc., F.R.S.

The College provides practical scientific training for students who desire to become Civil, Mechanical, or Electrical Engineers, or Chemists.

Candidates are required to pass an Entrance Examination in Mathematics and English, but the Matriculation Certificate of any British University, and certain other qualifications, are accepted in lieu of it. The next Entrance Examination will be held on Tuesday, September 19. Applications for admission should be forwarded to the College on forms to be obtained from the REGISTRAR. The programme of the College is under revision and will be issued shortly.

**UNIVERSITY OF ST. ANDREWS.**

DUNDEE SCHOOL OF SOCIAL STUDY AND TRAINING.

Chairman: PRINCIPAL OF THE UNIVERSITY.

TRAINING COURSE for students desirous of making social work their profession. Courses for graduates and non-graduates. University Diploma. Students are trained to become Welfare Workers, Club Leaders, After-Care Committee Workers, House Property Managers, etc., etc. Information relating to the training of Health Visitors under the Board of Health Scheme can also be obtained. There is accommodation for resident students at the Settlement. For Syllabus apply to the SECRETARY, St. Andrews University, or to the WARDEN, Grey Lodge Settlement, Dundee.

**SOUTH-WESTERN POLYTECHNIC INSTITUTE,**

CHELSEA, S.W.3.

Day and Evening Courses in Science under Recognised Teachers of London University.

**I. INDUSTRIAL CHEMISTRY DEPARTMENT.**

Technical Courses in Analytical and Manufacturing Chemistry, Pharmacy, Food and Drugs, A.I.C. Courses, Metallurgy, Assaying, Foundry Work, Research.

**II. INDUSTRIAL PHYSICS DEPARTMENT.**

Practical work in General Physics, Applications to Industries, Metrology, Calorimetry, Illumination, Acoustics, Electrical Measurement, Research.

**III. BIOLOGICAL AND GEOLOGICAL DEPARTMENT.**

Courses for B.Sc., etc., in Botany, Geology, Mineralogy, Zoology, Special Courses in Bio-chemistry, Bio-physics, Bacteriology, Physiology, Hygiene, Entomology, Plant Pathology. Course for Tropical Planters, Research.

SIDNEY SKINNER, M.A.,

Principal.

Telephone: Kensington 809.

**CIVILIAN EDUCATIONAL STAFF. ROYAL AIR FORCE.**

Applications are invited for vacant appointments as EDUCATION OFFICERS, Grade III, and Grade IV, on the Educational Staffs of the undermentioned establishments:

Boys' Wing, Royal Air Force, Cranwell, near Sleaford, Lincolnshire	Grade III.
No. 1 School of Technical Training (Boys), Halton, near Wendover, Bucks.	Grade III.
Electrical and Wireless School, Flower Down, near Winchester (Airmen and Boys).	Grades III. and IV.
School of Technical Training (Men), Manston, near Ramsgate.	Grades III. and IV.
R.A.F. Depot, Uxbridge (Airmen).	Grades III. and IV.

The Salary scales, to which Civil Service Bonus will be added, are given below. These scales are provisional and are now being reconsidered. Allowances up to ten increments of the scale can be made for previous experience and war service. Preference will be given to candidates who have served as commissioned officers in any of the three Services. The principal subjects of instruction are English, Practical Mathematics, Applied Mechanics and Drawing.

Grade III. (Graduate) £150-£10-£200-£15-£350.

With current Civil Service bonus, approximately . . . £274-£353.

Grade IV. £110-£10-£275 . . . £214-£350.

Applications must be made on A.M. Form 69, which, together with further particulars, can be obtained from the SECRETARY, A.E., AIR MINISTRY, Kingsway, London, W.C.2.

**ROYAL NAVY.**

APPLICATIONS are invited for APPOINTMENTS as INSTRUCTOR LIUTENANTS in the Royal Navy.

Candidates must be under 30 years of age, have had a University Training, and have taken an Honours Degree in Mathematics, Science or Engineering.

Present rates of pay are from £365 per annum on entry to a maximum of £949 per annum as Instructor Commander.

Promotion, by selection, to Instructor Captain is also open, with a maximum of £1,277 10s. per annum.

Retired pay may be granted to Officers over 40 years of age, with a minimum of 12 years' service, up to a maximum of £450 a year for an Instructor Lieutenant Commander, £600 a year for an Instructor Commander, and £600 for an Instructor Captain, according to age and service.

Service victualling, cabin accommodation, and servant are provided, or allowances in lieu.

An allowance of £50 towards the provision of necessary uniform is payable on satisfactory completion of probationary service.

For further particulars apply in the first instance to the SECRETARY OF THE ADMIRALTY, Whitehall, S.W.1.

**UNIVERSITY OF BERDEEN.**

CHAIR OF NATURAL PHILOSOPHY.

The CHAIR OF NATURAL PHILOSOPHY in the patronage of the University Court becomes vacant by the resignation of Professor Niven, F.R.S., on September 29, 1922.

The University Court will proceed to consider an appointment to the Chair on July 25, 1922. The Salary proposed is £1,100.

H. J. BUTCHART,

Marischal College, Aberdeen. Secretary to the University

**DERBY TECHNICAL COLLEGE.**

AN ASSISTANT LECTURER and DEMONSTRATOR in CHEMISTRY will be required in September next. Good qualifications essential. Burnham scale. Forms of application may be obtained from the PRINCIPAL.

F. C. SMITHARD,

Secretary to the Derby Education Committee.



SATURDAY, JULY 8, 1922.

## CONTENTS.

	PAGE
Metric and British Measures. By R. J. T.	29
Influenza	30
History of Electrotherapy	32
Mustard Gas Poisoning. By Prof. C. Lovatt Evans	32
Tinctorial Chemistry and Histology. By Dr. M. Nierenstein	33
Mineral Resources of Yugoslavia. By H. L.	33
Hydraulics. By F. C. L.	34
Our Bookshelf	35
Letters to the Editor:—	
The Difference between Series Spectra of Isotopes.—	
Prof. J. W. Nicholson, F.R.S.	37
A Possible Reconciliation of the Atomic Models of	
Bohn and of Lewis and Langmuir.—W. Hughes	37
The Intensity of X-ray Reflection from Powdered	
Crystals.—Prof. A. H. Compton and Newell L.	
Freeman	38
Discoveries in Tropical Medicine.—Sir Ronald	
Ross, K.C.B., F.R.S.	38
The Oldest known Rocks of the Earth's Crust.—	
Prof. Grenville A. J. Cole, F.R.S.	39
An Exception to the Principle of Selection in Spectra.	
—S. Datta	39
The Melbourne University Bill.—Sir. J. H.	
MacFarland	39
Ball Lightning.—Prof. J. B. Cleland	40
Ouramoeba.—F. R. Rowley; R. Kirkpatrick	40
The Elliptic Logarithmic Spiral.—C. E. Wright	40
Seasonal Incidence of the Births of Eminent People.	
—Dr. F. J. Allen	40
The Paris and Liège Meetings of the Institution of	
Mechanical Engineers	41
Absolute Measurements of Sound. (Illustrated.) By	
Dr. Arthur Gordon Webster	42
Biological Studies in Madeira. By Dr. Michael	
Graham	45
Ten Years of X-ray Crystal Analysis. By Dr. A. E.	
H. Tutton, F.R.S.	47
Obituary	48
Current Topics and Events	50
Our Astronomical Column	53
Research Items	54
Coral Reefs of the Louisiade Archipelago. By Prof.	
W. M. Davis	56
Root Respiration. By W. E. B.	58
Radio Direction Finding in Flying Machines	59
Industrial Research in India	59
Rainfall in Southern Italy and Tripoli	60
University and Educational Intelligence	60
Calendar of Industrial Pioneers	61
Societies and Academies	62
Official Publications Received—Diary of Societies	64

Editorial and Publishing Offices:

MACMILLAN & CO., LTD.,

ST. MARTIN'S STREET, LONDON, W.C.2.

Advertisements and business letters should be  
addressed to the Publishers.

Editorial communications to the Editor.

Telegraphic Address: PHUSIS, LONDON.

Telephone Number: GERRARD 8830.

NO. 2749, VOL. 110]

## Metric and British Measures.

IN view of the vigorous and sustained efforts of the exponents of the metric system, and the eminent names that are to be found among them, it is perhaps not a little surprising that it makes so little progress towards general acceptance in Great Britain. The Weights and Measures Act of 1897 legalised the metric denominations for use in trade, and was expected to lead to its advantages being so generally recognised that the Imperial system would soon disappear. Twenty-five years have now elapsed, and the position is almost unchanged. In fact, the policy of compulsory introduction of the metric system by law, which formerly was always strongly supported, was ruled out by the Metric Committee of the Conjoint Board of Scientific Societies in its Report in 1919, and though the report of this Committee was not adopted by the Board, the subject of compulsion is not likely again to be seriously considered for some time at least. Even the Decimal Association has recognised this position, and now advocates a modification of the Imperial system which will serve as a first step towards facilitating the ultimate end it has in view. A modification of some sort is now being called for with increasing insistence, so that it may be desirable to examine the principal considerations involved.

A fundamental distinction must, at the very outset, be drawn between the importance of stability in the units of quantity and of dimension respectively. The units of mass and capacity, speaking generally, serve simply for determining a certain quantity of goods, and the margin of tolerance is usually fairly large; and even if this margin is greatly exceeded, the loss, to one or the other party to the transaction, is the value represented by the amount of the error alone. An alteration in the magnitude of these units, therefore, if not very large, would pass almost unnoticed. Material weights, and to a certain extent measures also, can be adjusted without any great difficulty, though the recalibration of weighing machines would not be quite so simple. The unit of length is of a different character. Size, which determines the interchangeability of parts and fittings, is not capable of ready adjustment, and an error in dimensions often involves the waste of the whole article. A change from one unit to another, not commensurable with it, must therefore introduce serious difficulty, in that apparatus designed to suit one unit cannot easily be adapted to be of service under the other. The only kind of change which could be accepted without much inconvenience would be one which left the new unit expressible, in the terms of the old, by a simple ratio, the absolute change of magnitude being of minor

importance. It was this point which went far towards determining the general trend of the Report of the Committee of the Conjoint Board.

The present policy of the Decimal Association must be examined with this difference in mind. The Association suggests a step-by-step transition, leading to a gradual familiarisation of the country with metric units, until the opposition is so far reduced that a compulsory metric system Act becomes possible. As a first step, the pound avoirdupois is to be readjusted so as to become exactly equal to half a kilogram—an increase of about 10 per cent. The official policy of the Association is to alter the ounce, dram, and grain similarly, retaining their present ratios. Dr. Guillaume prefers, if there is to be a "piecemeal" policy, to make the new pound (500 grams), contain 20 ounces, 250 drams, and 10,000 grains, the percentage changes in magnitude being of about the same order, but not all in the same direction.

It will be seen that, in itself, a change of this sort could probably be made without serious difficulty, if it were thought to be necessary. That is to say, if a deliberate and agreed decision had been come to that the metric system exclusively was to be employed in Great Britain, the transition might well have been begun in this way. In the absence of such a decision, the position is less clear. A certain amount of inconvenience must inevitably arise, particularly in the introduction of a new series of weights and measures in retail trade; and although the ultimate introduction of the metric system might be facilitated by the proposed modification, it is scarcely likely that those who are opposed to the end in view will offer any less opposition to the means employed. Faced with the ultimate proposal, that the inch should be altered to constitute one-fortieth of a metre—and this is probably the least objectionable line of action open—no concession is to be expected from opponents in favour of a first step, which does not, in itself, present very obvious advantages. It is probably far too seldom realised that the great objection to the metric system is based upon the incommensurability of the British and metric units of length. The real battle lies between the inch and the centimetre. If the alteration of either, to make it commensurable with the other, could be admitted, then its ultimate abolition could follow without much difficulty.

The view is quite widely held that the Imperial units are, as magnitudes, more suitable for commercial purposes than the metric. There is, therefore, at least a possibility that the solution of the metric controversy may be found in the development of a system based upon the British units, but so modified as to be capable of treatment on pure decimal lines. The

Report of the Committee of the Conjoint Board suggests that the possibilities of such a solution should be explored, and one experiment in this direction has already been tried with success. The troy pound was abolished in 1878, but the troy ounce was too firmly established to be dismissed entirely. Trade in the precious metals, however, is now carried on in terms of troy ounces only, and bullion weights are made up solely in decimal multiples and sub-multiples of that unit. There has certainly been some activity in this direction in recent years, and should a really logical system upon a decimal basis be devised and secure general acceptance in the countries now using Imperial units, it may be found that these units are, after all, destined to survive.

R. J. T.

### Influenza.

*Influenza: Essays by several Authors.* Edited by F. G. Crookshank. Pp. xii+529. (London: W. Heinemann (Medical Books), Ltd., 1922.) 30s. net.

A VALUABLE series of essays is given in this volume, bringing our knowledge of this devastating disease up-to-date, and at the same time demonstrating the nebulous character of this knowledge and our impotence in face of its recurring pandemics. From the wider point of view the contributions of Drs. Crookshank and W. H. Hamer are especially valuable. The seven chapters contributed by Dr. Crookshank would have been even more valuable than they now are, had he condensed them and treated his subject more systematically. They bear evidence of previous separate publication, with considerable repetition and occasional laxness in sequence of matter.

The rest of the volume is occupied by chapters on the clinical and therapeutic aspects of influenza, which need not detain us, and by a chapter of 175 pages dealing with the bacteriology of influenza, which would have gained greatly by severe condensation.

The chief interest of the volume, however, consists in a full statement of the special views respecting influenza which the lucid and skilful writing of Dr. Hamer, ably seconded by Dr. Crookshank, has rendered important; and every one wishing to study the epidemiology of influenza, and to learn another view than that apparently favoured in the official report of the Ministry of Health, will need to study these chapters carefully.

The question at issue is whether influenza, in the various forms which are usually recognised as this disease, is a single specific disease, due to a special contagium, which may or may not be the Pfeiffer bacillus; or whether the same virus may not also be the cause of "phases" of influenza, including cases



in which the nervous centres are seriously affected, and in which the varieties of disease included in the Heine-Medin symptom complex occur.

Dr. Hamer evidently looks to a filter-passing organism as the likely key to the position, and avers that "most of the 'causal organisms' of bacteriology can be shown to be mere upstart associated organisms or secondary invaders." Using Dr. Crookshank's conception that three fundamental factors are concerned, namely, the disease, the epidemic, and the epidemic constitution, Dr. Hamer advocates the hypothesis that the cause of the disease, of the epidemic, and of the epidemic constitution "is the mutating *vera causa* or primary influence," which may be some ultra-visible organism. Much stress is laid on the epidemics which commonly precede and follow, or are associated with, typical influenza. Dr. Hamer evidently thinks that much of the trench fever in the recent war was influenza. This may be so, in a proportion of the cases in which an error of diagnosis was made; but this would not apply to the cases of true trench fever, the communicability of which by body lice has been demonstrated. A reference to Malta fever is similarly confusing; for if this is to be regarded as belonging to the large influenzoid group, it is remarkable that it should be entirely preventible by boiling all goat's milk which is consumed by human beings. In Dr. Hamer's words, "in thickly inhabited areas of the globe a kind of law of coincidence or of overlapping of cerebro-spinal fever and poliomyelitis and pandemic influenza" is visible. This relationship it is maintained is "not simply and solely one of concurrence, but of regulated development in definite sequence," and Creighton, our leading historical epidemiologist, is quoted in favour of the contention that we must keep in mind "gradations, modifications, affinities," and be "careless of symmetry, of definitions or clear-cut nosological ideas, or the dividing lines of a classification."

With this general proposition we are in accord, and we may agree also that fixity of type of epidemic diseases and their causal organisms is not to be assumed; but, taking the three diseases just named, it requires much imagination even to assume that they can all be due to variants of a common infection. Our knowledge of the infecting agent in poliomyelitis is now considerable; and although the proof that the meningococcus is the cause of cerebro-spinal fever is not absolutely complete, the converging evidence of bacteriology and vaccinal treatment is strongly in favour of this conclusion. Without adequate reason, to assume that the contagia of diseases which are commonly associated are variants of a common contagium is a retrograde scientific step; it appears much more probable that the true explanation of the frequent association or sequence

of influenza, poliomyelitis, encephalitis lethargica, and cerebro-spinal fever is that the "epidemic constitution" in these years favours the whole group of infections and not merely one of them—influenza. There is close analogy between this view and the view which explains the coincidences and sequences in seasonal and pandemic occurrence of scarlet fever, peruperal fever, rheumatic fever, diphtheria, to which attention has been directed in investigations by Longstaff and Newsholme. It can scarcely be contended that all these diseases are manifestations of a common infecting agency.

The view just stated appears to be confirmed in the article in the present volume by Dr. Dwight Lewis of Newhaven, U.S.A. Classical influenza, in his view, is caused by the Pfeiffer bacillus, but "the various waves of the so-called pandemic of influenza were caused by consecutive and increasing prevalences of correlated diseases due to the activation of carriers of the organisms of these diseases, whether by the influenza bacillus or by the streptococcus." There is no difficulty in believing in what we may call a first-cousinship of diseases, in the influence of one or other of these in increasing the virulence of another, and especially in believing in the death-dealing quality of their combined operation, as, for example, that of the organism of influenza and of the *Streptococcus hemolyticus*.

The criticisms in the last chapter of the Government report on influenza are interesting. There is just enough truth in the statement that "what is not recorded, or is not known to be recorded, does not officially happen," to give it tang.

Dr. Crookshank appears to differ gently from Dr. Hamer in the description of the intercurrent maladies as "phases of influenza," and suggests that these "specialised" epidemics should be described as *influenzoid*. With considerable imagination, he suggests that the recognition of these would be the first step towards the foretelling of the imminence of pandemic influenza. If this ever become practicable, it will constitute an important advance in our knowledge; but meanwhile we are all familiar with sporadic cases of these diseases which are not followed by epidemic influenza.

In short, this contribution to the subject is provocative of thought; and we hope also that it will lead to more exact epidemiological as well as bacteriological investigation. It presents a better philosophy of epidemicity than is usual; and Dr. Crookshank's contributions on this aspect of the problem will repay study. We rather think, however, that he is somewhat astray in apparently thinking that the importance of "epidemic constitution"—as a factor in producing pandemicity—is not generally recognised. This is the

mystery of mysteries, and we have not yet approached its solution. But we must approach it; for recurring pandemics of influenza like the recent one are more serious to civilised mankind than even the Great War.

### History of Electrotherapy.

*An Essay on the History of Electrotherapy and Diagnosis.*

By Hector A. Colwell. Pp. xv + 180. (London: W. Heinemann (Medical Books) Ltd., 1922.) 17s. 6d. net.

AN essay of 171 pages indicates a healthy respect for the subject treated and this is handed on to the reader who peruses it. Dr. Colwell has in some ways been fortunate in his subject, because it is one which yields to historical treatment when approached by a scholar. Of the evidences of this latter quality there is plenty of proof throughout this essay; there is a happy blending of historical accuracy, judgment in selection of facts, and a sense of the real importance of the subject of electrotherapy. The parent subject is now rather apt to be somewhat eclipsed by the more youthful one of radio-therapy, yet the benefit derived from electro-therapeutic measures in diagnosis and in the treatment of many diseases is a matter which need not be laboured.

Perhaps more than in any other branch of the healing art, the scientific advance of the subject to its present position has been one long series of spasmodic efforts interspersed between long periods of quiescence and indeed neglect. The neglect was probably the rational outcome of the conditions of quackery which often showed itself in the application of electricity to the ills of the human body. It is probably not very far from the truth to correlate this halting progress of the subject with the parallel state of affairs in the study and researches of a physical character into the nature of electricity itself.

It is interesting to read that a professor of physics, one Jallabert of Genoa, is to be regarded as the first scientific electrotherapist; for it is a matter of history that, in 1747, in collaboration with the surgeon Guyot, the electrical current was employed by him to produce muscular contractions in injured limbs, thus giving them the exercise necessary for the restoration of their normal functions. Though this is the case, the founding of modern electrotherapy occurred almost a century later as a result of the work of Duchenne of Boulogne.

The essay traces the growth of the subject to the present day. The last forty pages are devoted to the subject of radiology, but perhaps the lapse of time since the discovery of X-rays has been insufficient for a successful treatment of the subject on historical lines. Four pages of notes and an index complete a volume

which is very well produced and illustrated by a number of plates of great individual interest.

The author is to be congratulated on an essay which marks out so clearly the milestones which have been passed and the obstructions which have been met in the journey of electrotherapy to its present-day status.

### Mustard Gas Poisoning.

*The Medical Aspects of Mustard Gas Poisoning.* By Prof. A. S. Martin and Dr. C. V. Weller. Pp. 267. (London: Henry Kimpton, 1919.) 42s. net.

THIS volume is a belated account of investigations carried out at Michigan during the war; in 1917 it would have been eagerly welcomed, at the date of publication which it bears it would have been decidedly interesting, at the present time it will only be so to specialists and historians. It tells, with a wealth of detail which seems needless, of the effects of  $\beta$ - $\beta$ -dichlorethyl sulphide, or mustard "gas," on various animals and on men accidentally gassed with it at factories in America where the substance was manufactured for gas offensive purposes during the war.

The substance is a general protoplasmic poison, readily penetrating the epidermis and other tissues; once inside the cells it is probably hydrolysed, and the extensive damage is due to local liberation of hydrochloric acid. The chief effects are therefore a destruction of all the cells with which the substance comes into contact; the eyes, lungs, and skin are the most likely to be affected, and the danger lies chiefly in the fact that the substance has but little smell, so that dangerous concentrations may be encountered without arousing suspicions in those unacquainted with the properties. As the substance is a liquid of high boiling-point, soil or other materials which have been fouled with it may remain a source of danger for days.

Treatment of the affected parts is directed chiefly to the alleviation of symptoms; chlorine destroys the substance, so that local application of hypochlorites is useful in the treatment of skin burns, which are the most troublesome effects likely to be met with in men whose eyes and lungs are protected by the wearing of respirators.

The reviewer himself worked out the chief physiological effects of this substance on animals in the spring of 1916, at the suggestion of his colleague Dr. H. W. Dudley; the results were reported through the proper channels, but were not published. The Germans first used the substance some fifteen months afterwards.

The work before us is the most complete and accurate

account of the subject of mustard gas poisoning extant. Let us hope that it will be long before such a book is needed again; should there be another big war in our time, this work will provide a complete account of the properties of a substance which, had it been used earlier in the recent war, would almost certainly have proved a deciding factor.

C. LOVATT EVANS.

### Tinctorial Chemistry and Histology.

*Untersuchungen über Echtfärbung der Zellkerne mit künstlichen Beizenfarbstoffen und die Theorie des histologischen Färbeprozesses mit gelösten Lacken.* Von Prof. Dr. Siegfried Becher. Pp. xx+318. (Berlin: Gebrüder Borntraeger, 1921.) 10s. 6d.

THERE have been several attempts to evolve a scientific basis of the staining processes which are used in histology, but nothing as comprehensive as the book under review has so far been produced. It is the outcome of more than twenty years of research on the application of tinctorial chemistry to histology. The book contains a remarkable amount of sound chemistry, and one cannot but wonder how a professor of zoology and comparative anatomy could have found the time to acquire such profound knowledge of a subject so removed from his special lines of thought and study. Dr. Becher has been very successful in the manner in which he has combined histology with chemistry, and even the few peculiarities in his chemical terminology and chemical formulæ, such as, for example, his eccentric formula:

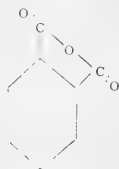

for phthalic anhydride, only add to the peculiar charm of the book. They vouch, at least, for the fact that the author has not blindly copied his chemical matter, which is too often the case when biologists develop chemical tendencies.

That the rituals of histology will have to give place to chemical common sense is evident from Becher's researches, which show conclusively that successful staining depends on one factor only, namely a well selected "triple-alliance" (a *bon mot* presumably chosen by Dr. Becher before the War) of tissue, mordant, and stain. Careful considerations of the individual and combined chemical properties of these three factors lead to success, their neglect spells

failure. This is the *leit-motif* of the whole research, which is abundantly supported by more than 2000 experiments. Becher's researches lead him also to the following generalisations, namely (1) the solubility of the "lakes" (metallic compounds of organic colouring matters) is of great importance, for good staining depends not on the solubility of the dye, but on that of the "lake," and (2) that all "lakes" of the hydroxy-anthraquinones are of general use for nuclear staining. The hydroxy-anthraquinones have been specially studied by Becher and the attention of histologists may be directed to pp. 271-275, which give a practical summary of these results.

However, not only histologists, but also chemists will find much in this book that will be of interest to them. There is too much belief in the infallibility of Griebler's stains in histological circles and the British dye industry would, perhaps, be well advised to pay some attention to this particular aspect of tinctorial chemistry. That not only Germany but also other countries manufacture dyes which give good histological results is again also evident from the work under review, since Dr. Becher has successfully used French, Swiss, Dutch, Belgian, and British dyes.

Reference might, perhaps, be made to a few minor errors, such as the statement on p. 121 that ellagic acid was synthesised by Georgievic in 1913, whereas it was actually synthesised by Perkin and Nierenstein in 1905. Such slight defects, however, detract little or nothing from the value of the book, which is certainly the best of its kind so far published.

M. NIERENSTEIN.

### Mineral Resources of Yugoslavia.

*The Geology and Mineral Resources of the Serb-Croat-Slovene State: Being the Report of the Geologist attached to the British Economic Mission to Serbia.* By D. A. Wray. (Department of Overseas Trade. Ref. No. F.E. 383). Pp. 111. (London: H.M. Stationery Office, 1921.) 3s. 6d. net.

THE Department of Overseas Trade has rendered a distinct service to economic geologists in publishing an account of the mineral resources of Yugoslavia, because our knowledge of this subject has hitherto been decidedly fragmentary. A few of the mineral deposits have long been well known, such as the mercury mines of Idriza, the copper mines of Majdanpek and the iron mines of Vares, but systematic information was lacking, and this has now been supplied by the painstaking work of Mr. D. A. Wray.

After a brief introduction dealing with the more important general and economic features of the new

state of Yugoslavia, we have first a brief but clear account of the geological structure of the region under discussion; it is greatly to be regretted that this part of the work was not illustrated by a geological map of some kind, even though it were only a small sketch map, as this would have been extremely helpful for a proper understanding of the somewhat complex geology. The various mineral deposits are next described in much detail, this constituting the principal and indeed the most valuable portion of the work. Under the heading of coal it is shown that true bituminous coal is very scarce, but that there are considerable reserves of lignites, which amount probably to about 1900 millions of tons, whilst the possible reserves are even greater. With the exceptions of some of the smaller beds of Liassic and Cretaceous coal in Serbia, all the coals are of Tertiary age and are for the most part of inferior quality, their calorific power lying usually between 4000 and 5000 calories. They can, however, be used successfully on railways, for steam raising and for domestic purposes, but are not suited for metallurgical operations or other work where high temperatures are required. Apparently the coal resources of the State would cover satisfactorily the great majority of its requirements, were it not for the grave lack of means of communication, which also has hindered in no small degree the development of the various coal-fields.

There are quite a number of deposits of iron ore; according to Dr. Katzer, the Government geologist, the more or less known reserves of iron ore amount to some 22 million tons, of which 15 millions are limonite. Mr. Wray is of opinion that "the total reserve tonnage may safely be computed at 30 to 40 million metric tons." The iron industry is, however, quite insignificant; there are a few small blast-furnaces, chiefly in the Vares district, charcoal being apparently the only fuel used; one of these furnaces, situated at Krapuli, 2 kilometres south of Vares, is said to have a daily output of more than 100 tons of pig iron, probably the largest ever obtained from a charcoal furnace. Owing to the want of good coking coals and the defective means of transport, there seems at present little probability that this industry can attain dimensions of any importance.

There are well-known copper mines at Majdanpek, which have been worked since Roman times; the output from 1870 to 1890 is stated to have totalled about 2500 tons of copper. Another important group of mines is that of Bor, now being worked by a French company; the production is said to have gone up to the high figure of 7575 metric tons of copper in the year 1911-12. The famous quicksilver mines of Idria have been worked ever since the fifteenth century,

the annual output since 1900 having been of the order of 500 tons.

Among the other minerals that have been or are being worked may be named iron pyrites, manganese ore, chrome ore, antimony ore, gold, lead ore, zinc ore, bauxite, meerscham and rock-salt.

It will be clear that Mr. Wray has done his work extremely well and has collected a great bulk of very valuable information. It is, however, to be regretted that he did not submit his proofs for revision to some competent metallurgist, as several blunders forming serious blemishes in the report would in this way have been detected. For instance, Mr. Wray states that there are at Majdanpek "three furnaces of the 'Knudsen' type (Sulitelma and Co., Norway)," whereas the Knudsen process is conducted in a special form of converter, and was worked out by the inventor at the well-known Sulitelma mines. Again, his description of the "Majdan" furnaces, evidently a primitive form of blast-furnace, is quite unintelligible; he writes: "The pig-iron came out in part with the scoræ, and in part remained in the bottom of the furnace. The latter product was much preferred, as by the continual action of swiftly-moving hammers (driven by water-power) it lent itself directly to treatment." It is obvious that if this material was pig-iron, it could not have been worked under the hammer, and we are left in doubt whether it was malleable iron or steel, or whether it really was pig-iron which was converted into malleable iron in some kind of a finery; either of these might be the correct explanation, whereas the statement as it stands is obviously incorrect.

H. L.

### Hydraulics.

*Hydraulics with Working Tables.* By E. S. Bellasis. Third Edition. Pp. viii + 348. (London: Chapman and Hall, Ltd., 1920.) Price 18s. net.

HYDRAULICS is largely an empirical science and as experience accumulates it is to be expected that the formulæ expressing the flow of water in particular conditions will be modified either in form or by a change in the experimental coefficients. The author of the book before us has had considerable experience in the irrigation department of India, and it might have been expected, therefore, that new data confirming or modifying generally accepted formulæ would have been incorporated; particularly additions to knowledge in those cases in which the experimental work has been small might have been forthcoming in this work. We look in vain, however, for such new data; the author has been content to discuss certain principles, to accept the generally accepted formulæ and to illus-

trate their applications in connexion with important practical problems. To determine the flow in pipes and channels the author adheres to the old Chezy formula and gives tables of values of the coefficient *C*. He not unreasonably points out that this formula has the advantage of simplicity over the logarithmic formulae, but he does not adduce evidence from his experience as to the comparative accuracy of the results they give. Thus the serious student of hydraulics can scarcely be satisfied with the treatment.

The chapter dealing with variable flow in open channels is of considerable interest and importance, and contains valuable suggestions to those who deal with such channels, especially when the streams are dammed by weirs and barrages. The correct form of the surface up stream from such barrages is, however, not satisfactorily discussed; the problem is admittedly a difficult one, but of importance, and needs more adequate treatment than that given by the author.

The brief chapter on unsteady flow deals with the time of emptying vessels and with waves in open channels; there are also brief remarks on the effects of waves and floods assisting in scouring or causing deposits. The work concludes by a brief chapter on the dynamic effect of flowing water.

The student will find this work suitable for reading in conjunction with some work on hydraulics which deals with the subject from the fundamental rather than from the practical engineer's point of view. The development in the volume under notice is not sufficiently logical for the student desirous of understanding thoroughly the fundamentals of the subject, but he as well as the practising engineer will find it both useful and interesting. F. C. L.

### Our Bookshelf.

*Applied Entomology: An Introductory Text-book of Insects in their Relations to Man.* By Prof. H. T. Fernald. (Agricultural and Biological Publications.) Pp. xiv+386. (New York and London: McGraw-Hill Book Co., Inc., 1921.) 21s. net.

TEXT-BOOKS of applied entomology are usually compiled according to one of two methods. In one type of book the various injurious insects are classified and enumerated under their respective orders and in the other type they are dealt with under the crops or other objects with which they are associated. The first method, which is the one adopted by Prof. Fernald, is unquestionably the better way of presenting the subject to the elementary student. The alternative method is more adapted to the needs of a practical reference book, in which the primary consideration is to render the information available by means of the most convenient, although not necessarily the most scientific, manner of presentation.

Prof. Fernald has carried out his task with conspicuous ability, and the book is certainly worthy of the Massachusetts school of entomology. Within a compass of less than 400 pages he manages to give the essential facts concerning the biology and control of all the more important insects affecting man, either directly or indirectly, in the United States. The general introductory chapters are perhaps a little too much abbreviated; nevertheless, they contain the essential elementary facts concerning the structure and metamorphoses of insects, and the principles of control commonly in vogue. Twenty-four orders of insects are recognised, and each is dealt with in turn, whether it contains injurious species or not. The student is thus enabled to view the class *Insecta* more or less as a whole, and appreciate the place of each order in the scheme of nature. The work is adequately illustrated and well printed. A few misprints are noticeable in the explanatory text relating to eight or nine of the illustrations, but they are not sufficiently serious to detract from the value of the book. A. D. IMMS.

*Exploration of Air: Out of the World North of Nigeria.* By A. Buchanan. Pp. xxiv+258. (London: John Murray, 1921.) 16s. net.

THE journey which Mr. Buchanan describes in this volume was undertaken at the instance of Lord Rothschild. Its object was to link up the chain of zoological geography across the country lying between Algeria and Nigeria. Starting from Kano in Northern Nigeria, the author traversed the French Territoire Militaire du Niger of the Western Sudan and reached the mountainous region of Air, which had not been visited by any European since Dr. Barth passed through it seventy years ago. Mr. Buchanan's style is vivid and his narrative racy; he touches but lightly on the hardships he had to endure in this arid section of the African continent. He is at his best when he describes the vicissitudes of tracking down some much coveted specimen. His accounts of the natives with whom he came into contact, although not sufficiently detailed to be of much value to the ethnologist, will give the general reader a very good idea of the character of these peoples. He devotes a chapter to the Touaregs of Air, in which he gives a very fair account of the more salient elements of their culture and of their costume, of which the veil worn by the men is the most characteristic feature. It is to be regretted, however, that he has not given a more detailed description of a people so little known.

*The Principles of Radiography.* By Dr. J. A. Crowther. Pp. vii+138. (London: J. and A. Churchill, 1922.) 7s. 6d. net.

DR. CROWTHER'S book is intended primarily for those beginning the study and practice of medical radiology, to whom it should be of considerable service. The author gives in a lucid and practical manner an account of the principles involved in the production of a skiagram and the mode of construction and action of the apparatus used. The subject-matter of the book forms part of a series of lectures given by the author to candidates for the Diploma in Medical Radiology and Electrology at Cambridge University.

The elementary principles receive full treatment, nearly fifty pages being devoted to their consideration. After a description of the properties of X-rays and the peculiarities of X-ray tubes, the production of high-tension currents is treated. The remaining chapters are devoted to the various parts of an X-ray installation, the actual taking of skiagrams, and the localisation of foreign bodies.

The description given to Fig. 25 will no doubt be altered in a future edition and the X-ray tube depicted in Fig. 26 be given terminals of different signs. Though written by a physicist, it is evident that the writer has had some practical experience in the radiography of the human subject, which enhances the value of the book.

*The Principles of Mechanical Refrigeration.* (A Study Course for Operating Engineers.) By Prof. H. J. MacIntire. Pp. viii+252. (New York and London: McGraw-Hill Book Co., Inc., 1922.) 12s. 6d.

THE engineering courses at our Universities and Technical Schools deal as a rule much more thoroughly with the conversion of heat into work than with the conversion of work into heat, or rather, into the absence of heat. This holds to a considerable extent for American universities and colleges, and it is for engineers so trained that the present volume is intended. Attention is directed chiefly to the details in which refrigerating machinery differs from the machinery with which the average engineer is familiar. It is probably due to the simplicity of the new problems which the ammonia refrigerating plant brings before the mechanical engineer that ammonia owes its popularity. The actual cost of producing a given amount of refrigeration is almost the same by the three or four methods at present in use, and the author of the present work thinks that the carbonic acid has many advantages over the ammonia method. Ethyl chloride used with a rotary compressor is extensively used in the American Marine, and much more information on the use of this material would be welcomed by refrigerating engineers in this country. The book contains tables of the properties of refrigerants compiled from Bureau of Standards reports, which are more up-to-date than any with which we are acquainted in books published in this country.

*The Stagers of Shakespeare.* By R. Crompton Rhodes. Pp. xii+102. (Birmingham: Cornish Bros., Ltd., 1922.) 4s. 6d. net.

MR. RHODES'S little book is an important contribution to the study of the stage-craft of Shakespeare and his contemporaries. His method has been to compare closely the stage directions of the quarto editions of the plays and those of the First Folio. He finds that in the quartos which are generally recognised as pirated, the stage directions have the character of observations rather than of instructions, as might be expected from the circumstances of their origin. As a result of the comparison, Mr. Rhodes is able to offer a number of suggestions as to the use of the curtains to provide a recess on the stage and the use of the balcony covering the three terms used by Shakespeare, "aloft," "above," and "at a window." His deduction that

in those cases in the First Folio, where there are no stage directions or very few—"The Two Gentlemen of Verona," "The Merry Wives of Windsor," "Measure for Measure," "The Winter's Tale," and "King John,"—we are dealing with a text assembled from the players' parts, deserves attention in the consideration of a difficult problem, for the solution of which Sir Sydney Lee's theory of transcripts in private hands does not appear entirely convincing.

*Twenty-Five Years in East Africa.* By Rev. John Roscoe. Pp. xvi+288+xix Plates. (Cambridge: At the University Press, 1921.) 25s. net.

IN this volume, Mr. Roscoe has given an account of some of his experiences and observations of the manners and customs of the natives of East Africa during his twenty-five years' service as a missionary in that area. In particular his aim has been to describe the condition of the country and the natives when first he took up his work. From this point of view, his book forms a useful pendant to the more strictly ethnographical works he has already published dealing with the Baganda and other Bantu tribes. The connected narrative adds colour to these analytical studies. When Mr. Roscoe first arrived in the country the Uganda railway, of course, was not in existence, and he gives a vivid picture of the difficulties encountered by the traveller, arising both from the character of the country and the untrustworthiness of the native carrier, the only means of transport. To many of his readers the most interesting section of the book will be that dealing with the events, of which he was an eye-witness, leading to our assumption of the Protectorate over Uganda. In this account, curiously enough, Sir Frederick Lugard is mentioned only incidentally.

*Joseph Glanvill and Psychical Research in the Seventeenth Century.* By H. Stanley Redgrove and I. M. L. Redgrove. Pp. 94. (London: William Rider and Son, Ltd., 1921.) 2s. 6d. net.

JOSEPH GLANVILL is no doubt best known to the modern reader as the source of inspiration of Matthew Arnold's well-known poem, and secondly as author of a treatise on witchcraft which W. E. H. Lecky described as "probably the ablest book ever published in defence of the superstition." It is not so generally known that Glanvill was an ardent advocate of the experimental method and a sturdy opponent of dogmatism. He was not only a Fellow of the Royal Society, being elected in 1664, and a friend and admirer of Robert Boyle, but in addition to making three communications to the society which appeared in the Transactions, he was the author of an account of the advances in the various departments of scientific knowledge since the time of the ancients. Incidentally in this work he suggested that the Torricellian vacuum was not an absolute void. In the short account of Glanvill under notice his various activities are noted and his views set forth, for the most part, in his own words. The authors are, however, chiefly interested in his psychic investigations, on account of which he may be considered, legitimately, to be the founder of modern psychical research.

## Letters to the Editor.

[The Editor does not hold himself responsible for opinions expressed by his correspondents. Neither can he undertake to return, or to correspond with the writers of, rejected manuscripts intended for this or any other part of NATURE. No notice is taken of anonymous communications.]

## The Difference between Series Spectra of Isotopes.

PROF. P. EHRENFEST and Prof. N. Bohr, in their letters to NATURE of June 10, have raised the interesting question of the difference to be expected between the spectra of isotopes. Much confusion, as their letters clearly indicate, exists on the subject, and while not in disagreement with any of their conclusions, I should like to make a few remarks which may tend to elucidate the matter somewhat further.

Prof. Ehrenfest raised the question in relation to the spectra of the isotopes of lithium—the subject of an investigation by Prof. Zeeman—and pointed out that the factor  $M/(m+M)$  in the Rydberg constant was only deduced by Bohr—and subsequently used by Fowler to obtain the best estimate we have for the ratio  $m/M$ , in his Bakerian lecture—for the case of an atom with a single electron. He justifiably rejects any conclusions founded on its application to atoms with more than one electron, and Prof. Bohr entirely concurs. Ehrenfest's illustration of an atom in which the mass of the nucleus, on account of symmetry, does not enter into the spectrum at all, is perhaps a sufficient indication of the difficulty of the problem, if such symmetrical atoms can exist, a matter which appears improbable.

The spectra of the lithium isotopes are at present peculiarly interesting since the announcement that Prof. McLennan has isolated them and found a difference which is greater than that calculated by the Bohr formula, and in fact three times this value, while 3 is the accepted atomic number of lithium. The quantum theory is unable to explain this large separation, and its exponents must doubt the fact that McLennan's new series is the spectrum of an isotope. There are two alternatives—it may be a combination series or a spark series. In an investigation which the present writer made a year ago, on some of the simpler possible orbits in a lithium atom with only two electrons, a specially simple class of orbits was found. Although the work is not yet published, it is possible to state that its result gave, as the principal spark-line of lithium, a value very close to  $\lambda 6708$ , the red line shown in the ordinary spectrum. This line had already been suspected, by several spectroscopists, to have a spark component.

In these simple orbits of a lithium atom positively charged, the two electrons are behaving very differently. The orbit of one of them is only about  $\frac{1}{3}$  the linear dimensions of that of the other, so that the Bohr formula for one electron is nearly applicable. In fact, the orbits are very closely analogous to those now generally accepted for the neutral helium atom, which can take two forms, in both of which the orbit of one electron is very small compared with that of the other; the orbits differ mainly in the fact that in ortho-helium they are practically coplanar, and in parhelium practically perpendicular.

I have found it possible by a choice of the simpler orbits, and by the supposition made by Sommerfeld and others as to the invariability of the energy  $W$  for all possible orbits, to show that the inner orbit has a radius only about  $\frac{1}{3}$  of that of the outer. Thus the Bohr formula is again nearly true, and the Rydberg constant in the ordinary helium series is not very different from its value in the Pickering series.

Such results are suggestive, and appear to indicate that when there are many electrons in an atom, a ratio roughly of order  $\frac{1}{3}$  exists between the orbital radii of the two outer consecutive electrons. An immediate consequence is that the Bohr formula would never be very far wrong in its use for a rough determination of the separation to be looked for in the spectra of isotopes. If the correspondence with these results does not, however, extend to heavier atoms, we are precluded from making any prediction without the knowledge of the general position—on the average—of the centre of mass of an atom. In a problem of this nature no general treatment is possible, and no general simple law of separation down the Periodic Table is to be expected.

J. W. NICHOLSON.

Balliol College, Oxford, June 12.

## A Possible Reconciliation of the Atomic Models of Bohr and of Lewis and Langmuir.

BROADLY speaking, the merits of Bohr's atomic model lie in its very accurate explanation of the reaction of atoms and molecules with radiation, while those of the Lewis-Langmuir model lie in its very satisfactory representation of the mechanism of chemical combination, but the merits of either model are lacking in the other. Both must therefore possess properties which are accurate representations of the truth, and the problem remains to devise a third model which will incorporate those properties in its structure. The following considerations lead to a modification of the Lewis-Langmuir model, which appears to be a satisfactory solution of the problem—so far as I am aware it is new.

Consider first the well-known Lewis-Langmuir model for any atom. It is built up of the central nucleus and its surrounding electrons the mean positions of which are fixed with respect to one another and to the position of the nucleus. Now in order to account for the reaction between the atom and radiant energy it is necessary to assume that these electrons possess acceleration of some kind. The particular kind most agreeable with the results of experiment is the orbital acceleration assumed by Bohr. But since the electrons are fixed (or can be assumed to move but very slightly from their fixed mean positions) in the Lewis-Langmuir model, orbital acceleration is impossible.

Now, apparently, a way out of this difficulty is to assume that the electron shells are fixed and the nucleus rotates on an axis.

By the Theory of Relativity it is immaterial whether—viewing a given atom—we regard the electrons as describing orbits around a fixed nucleus (not fixed in position only) or whether we regard the nucleus as rotating inside the electron shell or shells with each electron fixed relatively to the others. That is, the nucleus possesses acceleration with respect to the electrons, or what is the same thing, the electrons possess acceleration with respect to the nucleus in spite of the fact that they are fixed relatively to outside systems such as other electron shells. Therefore this model when viewed with respect to the electron shells is precisely the same as the Lewis-Langmuir model, and, furthermore, with respect to the whole atom it possesses all the merits of Bohr's model. That is, it appears to be a satisfactory reconciliation of the two atomic models.

Furthermore, the proposed model possesses the further merit that by its aid we can predict the existence of isotopes. Thus if the nucleus of a given atom possesses more than one stable axis of rotation with respect to itself, or to its surrounding shells of elec-

trons, or to both, and these axes are associated different amounts of energy, it is possible for the mass of the atom to be different for the different positions of the nuclear axis, since by the Theory of Relativity energy possesses mass. That is, the model proposed predicts the existence of isotopy. If the direction of the nuclear axis as described above is determined by the structure of the outer shell of electrons, we should expect the existence of different axes in the same atom to be favoured in those atoms the outer shells of which are complete (inert gases), nearly complete (halogens), or just forming (alkali metals). An inspection of Aston's list of isotopic elements shows that it is in the neighbourhood of the inert gases that the phenomenon of isotopy chiefly occurs.

W. HUGHES.

63 Goldington Avenue, Bedford.

### The Intensity of X-ray Reflection from Powdered Crystals.

In the May number of the *Philosophical Magazine* which has just reached us, Mr. C. G. Darwin has presented a most valuable discussion of the reflection of X-rays from imperfect crystals. He shows that, on account of the difficulty in determining the effective extinction coefficient of the X-rays in such crystals, it is very difficult to calculate with accuracy the intensity of the reflected beam. Hence he is unable to make a satisfactory comparison between the theoretical formulae and the existing experiments on the intensity of X-ray reflection. This result is in general agreement with the conclusion reached by one of us (*Physical Review*, July 1917) on the basis of somewhat similar considerations.

Mr. Darwin concludes that a more satisfactory test might be made on powdered crystals, since in this case the only factor contributing appreciably to the extinction is the ordinary absorption of the X-rays in the powder, which can be measured directly. We had arrived at the same conclusion, and have made quantitative measurements of the intensity of the X-rays scattered by powdered crystals.

In our most recent experiments, the  $K\alpha$  line from molybdenum ( $\lambda + 0.708 \text{ \AA}$ ), after reflection from a crystal of rock-salt, was allowed to fall upon a plate of powdered sodium chloride. The first order reflection from the [100] faces of the powdered crystals then entered the ionisation chamber. The method was thus similar to that employed by W. H. Bragg (*Proc. Phys. Soc., Lond.*, 33, 222, 1921) except that the primary rays were homogeneous. The ratio of the energy reflected into the ionisation chamber due to this first order line to that incident upon the plate was  $2.94 \times 10^{-4}$ , with a probable error of about 10 per cent. The theoretical intensity of the line was calculated from a formula identical in significance with Darwin's formula (10.4) (*loc. cit.*), except that correction was made for the absorption of the X-rays in the crystal mass. We thus obtained the value  $2.7 \times 10^{-4}$ , which is in satisfactory agreement with the experimental measurement. Thus, at least to a close degree of approximation, the theory of X-ray reflection based upon the classical electrical theory gives accurate results.

This comparison of theory with experiment may be viewed in another manner. Any formula for the intensity of X-ray reflection must depend upon the value of a function  $\psi$ , the magnitude of which is determined by the distribution of the electrons in the atoms. The theoretical value  $2.7 \times 10^{-4}$  mentioned above is based upon the value  $\psi^2 = 0.59$ , i.e. upon the assumption that the intensity is 59 per cent. as great as it would be if all the electrons in sodium and

chlorine were grouped together at the centres of their respective atoms. This value was estimated by one of us (*loc. cit.*) on the basis of some of W. H. Bragg's measurements of the relative intensity of the different orders of X-ray reflection from rock-salt. The corresponding value of  $\psi^2$  as determined by the measurements of W. L. Bragg, James and Bosanquet is 0.43 (*Phil. Mag.*, July 1921). To obtain our experimental value  $2.9 \times 10^{-4}$  for the intensity of reflection from powdered crystals, the value of  $\psi^2$  must, however, be 0.64. The difference between the latter two values of  $\psi^2$  supports Darwin's suggestion that the method employed by Bragg, James and Bosanquet for studying the intensity of X-ray reflection is not wholly trustworthy.

We hope in the near future to be able to report experimental results of a considerably higher degree of accuracy than those described above.

ARTHUR H. COMPTON.

NEWELL L. FREEMAN.

Washington University, Saint Louis, May 30.

### Discoveries in Tropical Medicine.

I AM much astonished to learn, for the first time, from Dr. L. W. Sambon's letter in *NATURE* of May 27, that during the whole period of my work in India (from April 1895 to February 1899) he "was almost daily at Manson's house" and was allowed to read my private letters to Manson and to "discuss every detail." Are we to understand by this that his almost daily visits to Manson's house continued for all this period, and that during it he read all my letters to Manson, numbering 110, and averaging a thousand words each in length; or merely that he read a few of the letters which Manson showed to him from time to time? Dr. Sambon would appear to claim the former interpretation of his words, because he proceeds to suggest that he is intimately acquainted, in consequence of his knowledge of these letters of mine, with all details concerning the relations between my work and the theories of Manson. If so, I can only say that I am amazed and hurt. In many of my letters to Manson were of a very private nature, and it is difficult for me to believe that he would have handed over the whole of this correspondence without reserve to a gentleman who was at the time a stranger to me and was in no way concerned with my affairs.

Moreover, when Manson sent some of my letters to Lord Lister he was, of course, careful to inform me of the fact; but he never mentioned the name of Dr. Sambon, so far as I remember, in all the fifty-six letters which he wrote me in reply to mine, as surely he would have done had he decided to submit my letters to a third person without my previous consent. Nor did Sir Patrick Manson ever mention this matter to me during the many years which have elapsed since the correspondence referred to ceased. On the other hand, if Dr. Sambon did not see all my letters to Manson, including the private letters, he cannot possibly have that close knowledge of my work which he seems to believe he possesses.

The remainder of Dr. Sambon's communication in *NATURE* referred to makes me still more doubtful regarding the interpretation which is to be placed upon his words; for it seems to me that he does not understand the said relations between my work and the theories of Sir Patrick Manson. May I also take the opportunity to state that I for one can scarcely accept as sound any of the conclusions which he has set forth in your columns in the letter referred to.

RONALD ROSS.



### The Oldest known Rocks of the Earth's Crust.

MAY I welcome Prof. A. P. Coleman's letter on "Geology and the Nebular Theory" in NATURE for June 17, p. 775? It must be admitted that the achievement of A. C. Lawson at Rainy Lake in 1887, the elucidation by Sederholm of the floor of Finland, and the illuminating work of Canadian geologists, including Coleman, Adams, and Barlow, on the Grenville Series, have been slow in penetrating academic circles in the British Isles. The doorways were almost closed against them, and against the views of French geologists also, by the dead-weight of theories of dynamic metamorphism. Yet our confidence in a fundamental "Lewisian" gneiss was well shaken thirty years ago by Sir A. Geikie's announcement that this rock penetrated a sedimentary series (see A. Geikie, "Text-book of Geology," 4th ed., vol. 2, p. 890); and a more detailed acquaintance with the ground would have led the same observer to withdraw his statement (*ibid.*, p. 895) as to a "violent unconformability" between gneisses and Dabradian sediments in north-west Ireland. Some of us have lost no opportunity of comparing the conditions in our homeland with those of broader Archæan areas. But even in our narrow lands, as I have ventured to urge from 1900 onwards, the teaching of the rocks themselves is unmistakable. The oldest known rocks are sediments, and the streaky structure of our ancient gneisses again and again records the stratification of ordinary sediments invaded by a granite magma.

I have recently put this view before those who may not be geologists in a volume of "unconventional essays," containing a chapter on "The search for the foundation-stones," where Prof. Coleman will find that his expositions have not been thrown away upon those whom he has so kindly guided in the field.

GRENVILLE A. J. COLE.

### An Exception to the Principle of Selection in Spectra.

IN a recent communication (*Phil. Mag.*, April 1922) Messrs. Foote, Mohler, and Meggers have described the excitation of a certain type of combination lines in a new form of discharge tube in which the applied electrostatic field can exert no influence upon the radiation. Thereby they made it somewhat doubtful whether these and other exceptions to the principle of selection can be attributed to the incipient Stark effect of the applied field, as suggested by Sommerfeld and others. In reply to this, Prof. N. Bohr has pointed out (*Phil. Mag.*, June, 1922) that, "owing to the screening from external forces, the experimental arrangement described would be especially favourable for the accumulation of ions in the region of the discharge tube," and that "the field due to the neighbouring ions and free electrons, to which the emitting atoms have been subject, may be of the order of magnitude claimed by the quantum theory for the appearance of the new lines." Consequently Prof. Bohr thinks that the results of Foote, Mohler, and Meggers do not furnish a sufficient basis for the conclusion they have drawn.

Recently, however, in the course of an investigation on the absorption spectrum of potassium, the results of which will be published shortly, the combination lines  $1s-2d$  ( $\lambda 4642$ ) and  $1s-3d$  ( $\lambda 3649$ ) have been obtained as absorption lines. The existence of free electrons and the consequent electrostatic field of atomic origin in the absorption tube is highly improbable. The present experiment therefore seems

to support the conclusion drawn by Messrs. Foote, Mohler, and Meggers.  
Spectroscopy Laboratory,  
Imperial College of Science and Technology,  
South Kensington, S.W.7.

### The Melbourne University Bill.

IN the issue of NATURE for March 16, which has just reached Australia, there is a leading article on the Melbourne University Bill. That Bill was drafted more than eighteen months ago, and though we have a Government in sympathy with the highest ideals of our University, it is still a Bill and has not yet become an Act of Parliament. In the article in question reference is made to a statement drawn up by the University Association of Teachers, in which the council of the university is criticised for failure adequately to protect the interests of the university and its staff.

It would be unseemly, and probably uninteresting to a large section of your readers, to enter into the merits of a "family quarrel" which is the result of misunderstanding and is, we hope, of a temporary character. A letter was sent by the council to the Minister for Public Instruction immediately after the council was informed that the statement to which you refer had been forwarded to members of the Cabinet by the University Association of Teachers. Let me point out a fact of which you may not be aware, namely, that while the association contains the majority of the teaching staff it does not represent the whole body of professors and lecturers. The statement of the association is crude and contains serious inaccuracies. I shall deal only with the two criticisms of the council which you single out.

(1) It "failed to protect the interests of the university by not raising fees." That is not a mere financial question—it involves a question of general policy. In view of the fact that an important section of our community believes that the university should charge no fees (the University of Western Australia is free), would it not be childish to raise the fees before Parliament has settled what our grant is to be, and till we know definitely whether that grant will enable us to pay adequate salaries without raising them?

(2) The council failed "by asking for an inadequate increase of the State Grant." I wish we could have an increase of the grant for the asking. I think the attitude of the council is clearly indicated by an extract from the letter to the Minister for Public Instruction already referred to. You will there find the following:

"The council is placed in a false position by being obliged to correct these statements, for it does not wish it to be inferred that it thinks the proposed increase of the University Grant sufficient for what are now in 1921 its legitimate needs."

The management of the university council may not satisfy the impatience of some, but no one interested in university education need fear that it will fail for lack of whole-hearted zeal.

J. H. MACFARLAND,  
Chancellor.

The University of Melbourne, May 5.

[The two criticisms to which Sir J. H. MacFarland, chancellor of the University of Melbourne, refers, were made by the University Association of Teachers, and we expressed no opinion upon them, but we remarked, "It is obvious that if a university staff is thoroughly discontented its efficiency is bound to suffer." The suggestions made at the end of our

article were offered in the hope that they would assist in settling the difficulties that had arisen between members of the staff and the council.—  
EDITOR, NATURE.]

### Ball Lightning.

AMONGST the notes in NATURE of August 4, 1921 (vol. 107, p. 722), is a reference to the occurrence of ball lightning during a thunderstorm at St. John's Wood on June 26. The phenomenon, it is added, is of great rarity. The following therefore, apparently another instance of this phenomenon, may be worthy of record in NATURE. It was communicated at the time to the Meteorological Office in Sydney. On the evening of January 13, 1920, a very severe thunderstorm with heavy rain occurred in Sydney. About 9 P.M. I went out on to the verandah of my house at Neutral Bay, which overlooked the harbour, to watch the progress of the storm. This was soon after its beginning, and the lightning was very vivid and frequent and the rain heavy. Looking towards Mosman Bay, I saw descending, rather slowly in an oscillating way, a large ball of light, seemingly about the size of a Chinese lantern. This took about two seconds to descend and be lost to sight in the hollow towards which Mosman Bay itself lay. The light seemed to have a violet tinge. No rays emanated from it. No noise was heard.

J. B. CLELAND.

The University, Adelaide, South Australia,  
May 8.

### Ouramoeba

I SHALL be glad to know whether any readers of NATURE interested in the Rhizopoda have met with specimens of Leidy's *Ouramoeba botulicauda*? While examining some squeezings of Sphagnum from Woodbury Common, near Exeter, a few days ago, I found an active individual and had it under observation for some time. Fig. 14 on Pl. IX of Leidy's "Fresh-water Rhizopods of North America" might have been drawn from my specimen.

It is now generally conceded that the characteristic jointed appendages are filaments of a parasitic alga, and Archer described amoebae in this condition, from Ireland, in 1866, but I am anxious to ascertain whether similar observations have since been made in other parts of Great Britain?

F. R. ROWLEY.

Royal Albert Memorial Museum, Exeter, June 8.

DR. W. L. POTEAT of Wake Forest College, N.C. (U.S.A.), published in NATURE of May 24, 1894 (vol. 50, p. 79), a letter recording his finding of *Ouramoeba* in Wake Forest, N.C., and asking for citations of other records. To this inquiry Mr. Rowley's note furnishes a late reply, for there has been no other (in NATURE) in the interval. There is now, however, a good deal of literature on the subject. *Ouramoeba*, as Dr. Poteat was the first to demonstrate beyond doubt, is simply *Amoeba* spp. (*A. nobilis* Penard, *protens* Rösel, *binucleata* Gruber, *villosa* Wallich) infested with fungal spores and filaments. In 1898, Mr. Martin F. Woodward of the Royal College of Science sent Dr. Poteat drawings of an infested *Amoeba* presumably found in the neighbourhood of London (*Science*, N.S. viii., 1898, p. 781). There does not appear to be any other record for England. The latest memoir by E. W. Gudger, "On Leidy's *Ouramoeba*," is in *Journ. Elisha Mitchell Sci. Soc.*, xxxii., 1916, p. 24.

R. KIRKPATRICK.

British Museum (Natural History), London, S.W.7.

### The Elliptic Logarithmic Spiral.

WITH reference to Dr. Rowell's letter in NATURE of June 3, p. 716, it may be pointed out that his curve, so far from being new, is briefly discussed in Besant's "Dynamics" (Besant and Ramsey, "Treatise on Dynamics," pp. 101-2). The equations of the curve may be written

$$x = a\xi + b\eta$$

$$y = \gamma\xi + \delta\eta$$

where  $(\xi, \eta)$  lies on a certain logarithmic spiral. The curve is thus obtainable from this spiral by a homogeneous strain, whence, amongst others, it will have the property that its various branches cut a radius vector at the same angle: this angle differing for different radii vectores.

C. E. WRIGHT.

Artillery College, Woolwich, June 19.

### Seasonal Incidence of the Births of Eminent People.

IN order to find, if possible, the causes which underlie the production of increased numbers of eminent intellects at certain periods (as, for example, the year 1809 and a year or two before and after it), I collected statistics of the dates of birth of more than two hundred eminent persons. The list consists chiefly of creative intellects,—poets, literati, musicians, painters, architects, men of science, explorers, and inventors, with a few statesmen and military men. Analysis of the dates shows that the greater number of these persons were born in the colder months of the year; but the distribution of the numbers is somewhat erratic. February is distinctly the richest month, having produced a galaxy of eminent persons; December comes next; August and June are the richest among the warm months.

Sixty pre-eminent names, chosen for no reason but their pre-eminence, were found to be distributed as follows:—In warmer months: April, 4; May, 6; June, 7; July, 2; August, 5; September, 3; total, 27. In colder months: October, 4; November, 1; December, 9; January, 5; February, 9; March, 5; total, 33.

The difference is more evident when the months are taken in groups of three, as follows: December to February, 23; March to May, 15; June to August, 14; September to November, 8.

In order to find whether this distribution corresponds with the ordinary distribution of births through the twelve months, I compared the numbers with the average of twelve years taken at a venture from the Registrar General's Quarterly Returns, namely, the period 1844-55. The figures are too numerous for quotation, but it may suffice to say that I could find no correspondence between the ordinary distribution of births and the distribution of births of eminent persons. In the Registrar General's Returns the order of average frequency for the quarter-years was as follows: April to June, July to September, January to March, October to December.

Climate can scarcely explain the distribution, (See letter from Dr. Robert W. Lawson, NATURE, June 3, p. 716.) Cold weather is not unhealthy for children, and in fact the diseases of the hot months are among the most fatal for them. I suggest that the reproductive organs, especially the germ cells, are more vigorous at certain seasons, producing offspring of higher quality. The many eminent persons born in the winter months, December to February, were conceived in the spring, the time of increased vigour of most living things; whereas the few born in the autumn months, September to November, were conceived in the winter.

F. J. ALLEN.

Cambridge, June 17, 1922.

## The Paris and Liège Meetings of the Institution of Mechanical Engineers.

THE summer meeting of the Institution of Mechanical Engineers was held on June 12-21 in Paris and Liège. In Paris the meetings were held in the Hall of the Société des Ingénieurs Civils de France. At the opening session M. Max Laubeuf, the president of the French society, and the engineer who more than any other has been responsible for the development of the submarine, received the president, Dr. H. S. Hele-Shaw, and members of the Institution of Mechanical Engineers, and addressed a few words of welcome. M. Laubeuf had expected to be away from France at the time of the meeting, and the formal address of welcome was therefore delivered by the vice-president, Prof. Leon Guillet.

The first paper was by Prof. Edouard Sauvage, on feed-water heaters for locomotives, in which various types were described, and the economies that might be expected from their use discussed. The second paper was an important contribution from Sir Vincent Raven on the electric locomotive. Broadly speaking, there are three types of locomotives required for the successful working of railways, namely: shunting, freight or goods, and passenger locomotives. For passenger traffic it is not so easy to standardise locomotives as for the other purposes, and considerable difficulties are met with in designing high-speed locomotives of great power. Particulars of a number of electric locomotives designed by the author and others were given, but the most interesting was an experimental locomotive that had been designed by Sir Vincent Raven, and built by the North Eastern Railway to haul a train of 450 tons, of sufficient power to start from rest on a rising gradient of 1 in 78, to reach a speed of 65 miles an hour on the level, and to run with safety at 90 miles per hour. The paper is an important one, and will arouse considerable interest. The chief engineer of the Paris-Lyon Railway, who is considering the same problems, spoke enthusiastically of Sir Vincent Raven's work. The agreement of these two engineers to compare their experiences is a real example of that *entente cordiale* which such gatherings must of necessity do so much to encourage. Lord Montagu of Beaulieu, in a paper on mechanical vehicles and road surfaces, directed attention to the economic importance of good road surfaces.

The first paper read on the second morning at Paris was a very important contribution by Prof. A. Rateau on the subject of rapid high-altitude flying. The author pointed out that the aeroplane is the only vehicle in which the resistance to travel is independent of the speed, and is directly proportional to the weight for the same angle of incidence. For high speeds, the aeroplane must select a height at which the density of the air is most suitable, and, providing the power of the engine can be maintained, high speeds can most easily be obtained at high altitudes. The rarefaction of the atmosphere at high altitudes makes it impossible without some special device to maintain the power of the engine, and, furthermore, pilots and passengers cannot exist in the rarefied atmosphere without special provision of oxygen, or being in an air-tight chamber to which air can be supplied under pressure. Prof. Rateau has attempted to overcome the former difficulty

by using exhaust gases from the engine to drive a turbine compressor which will supply air to the engine at ground-level pressure, and also, it is hoped, to the pilot and passengers in the air-tight chamber. Although in this country, in France, and in Germany a good deal of attention has been paid to supercharging of the engine in order to maintain power, Prof. Rateau's paper is the most serious contribution that has been published on the subject. In certain trials the turbo-compressor was made to revolve at speeds up to 53,000 revolutions per minute, giving a peripheral speed of 670 m. per second at the tips of the compressor. In the gas turbine, speeds were attained which gave stresses due to centrifugal force equal to 123,000 times the weight of the material. Moreover, the turbine is worked at a temperature of from 650° to 750° C., and thus very unusual demands are made upon the material.

Prof. Rateau's paper was followed by one on air-compressors by Mr. W. Reavell, of Ipswich, and this again by a paper on the supersaturated condition as shown by nozzle flow, by Prof. A. L. Mellanby and Mr. W. Kerr. It has been suggested that an explanation of the discharge through a nozzle being greater than that required by theory can be found by the assumption that the rate of change of pressure in a nozzle is so great that supersaturation of the steam takes place. The assumption is apparently justified by Wilson's experiments, but it is difficult to see how the conditions for a Wilson effect could be obtained in a nozzle. Prof. Mellanby's experiments confirm those of other workers in showing that the flow is greater than could possibly obtain if the steam did not become partially supersaturated. In the apparatus used search tubes were placed in the nozzles to determine the drop of pressure along the nozzle, and from an examination of these and the discharge through the nozzles, the condition of the steam was obtained. The experiments show that the flow at and near the dry state is excessive when compared with the theoretical, but that the form of the flow curve over a small range of superheat beyond the initially dry condition is not in agreement with the assumption of complete supersaturation.

The last paper read at Paris was one by Prof. F. C. Lea on the effect of temperature on some of the properties of metals, in which it was shown that the effect of temperature on the elastic properties of metals may be more important than upon the ultimate breaking strengths. The significance of this paper was well illustrated by the difficulties referred to by Prof. Rateau in his paper on turbo-compressors.

An interesting and important public lecture was given by Prof. E. G. Coker, on Recent Photo-Elastic Researches on Engineering Problems. The lecture was illustrated by a number of large scale experiments, showing the stress produced in wheel teeth transmitting power and in material being cut in the lathe in planing machines and in milling machines. The experiments aroused much interest and enthusiasm, and the lecturer is to be very sincerely congratulated upon the success of a lecture necessitating the conveyance to France of so much delicate apparatus.

A distinguished gathering was held at the Hôtel Continental on Thursday, June 15. Prof. Leon

Guillet, responding to the toast of the French engineering society, replied eloquently, recounting the work that had been done concurrently by French engineers and men of science in the many developments that had taken place during the last century.

Following the very successful meetings in Paris, members of the Institution journeyed to Liège to participate with l'Association des Ingénieurs sortis de l'École de Liège in the celebration of the seventy-fifth anniversary of the foundation of the Liège Society, which coincided also with the seventy-fifth anniversary of the foundation of the Institution of Mechanical Engineers. In connexion with this anniversary an international scientific congress and exhibition had been arranged by the Liège Society, and this was opened by the King of the Belgians on June 18. The members

of the Institution of Mechanical Engineers received invitations to the opening ceremony. The King in his opening address referred in particular to the importance of the work of men of science and of engineers in developing the resources of the world. On the days following the opening of the exhibition a number of papers were read at various sections of the Congress, and visits were arranged to works in the neighbourhood of Liège. Representatives of the French engineering society journeyed to Liège with the members of the Institution of Mechanical Engineers, and the association of the three societies proved of the greatest interest. It is believed and hoped that the celebrations will do much to bring about that rapprochement between the three peoples which is so essential for the future welfare of Europe and the world.

### Absolute Measurements of Sound.<sup>1</sup>

By Dr. ARTHUR GORDON WEBSTER, Professor of Physics, Clark University, Worcester, Mass., U.S.A.

IT is now more than thirty years since it occurred to me to devise an instrument that should be capable of measuring the intensity or loudness of any sound at any point in space, should be self-contained and portable, and should give its indications in absolute measure. By this is meant that the units should be such as do not depend on time, place, or the instrument, so that, though the instrument be destroyed and the observer dead, if his writings were preserved another instrument could be constructed from the specifications and the same sound reproduced a hundred or a thousand years later. The difficulty comes from the fact that the forces and amounts of energy involved in connexion even with very loud sounds are extremely small, as may be gathered from the statement that it would take approximately ten million cornets playing *fortissimo* to emit 1 horse-power of sound.

Before we can measure anything we must have a constant standard. In sound we must construct a standard which emits a sound of the simplest possible character, which we call a pure tone; it will be like that emitted under proper conditions by a tuning-fork, which is described by saying that the graph representing the change of pressure with the time shall be that simple curve known as the sinusoid or curve of sines. From this connexion we say that the pressure is a harmonic function of the time. Unfortunately, the pressure change is so small that at no point in a room, even when a person is speaking in a loud tone, does the pressure vary from the atmospheric pressure by more than a few millionths of an atmosphere. Thus we require a manometer millions of times as sensitive as an ordinary barometer, and, in addition, since the rhythmic changes occur, not once in an hour or day, but hundreds of times per second, if we wish the gauge to follow the rapid changes accurately, we have many mechanical difficulties.

The problem of a standard of emission has been solved by a number of persons, including Prof. Ernst Mach and Prof. Ludwig Boltzmann, and Dr. A. Zernov, of Petrograd, a pupil of the celebrated Peter Lebedeff. The problem of an absolute instrument for the reception and measurement of a pure tone has been also success-

fully dealt with by a number of investigators, among whom may be mentioned Prof. Max Wien, of wireless fame, the late Lord Rayleigh, and Lebedeff. But there remains a third step in the process, which is as important as the first and the second. Given the invention of the proper standard source of sound, which I have named the "phone," because it is *vox et praeterea nihil*, and of a proper measuring instrument, which should evidently be called a phonometer, there still remains the question of the distribution of the sound in space between the phone and the phonometer. Any measurements made in an enclosed space will be influenced by reflections from the walls, and, even if we had a room of perfectly simple geometrical form, say cubical, and were able to make the instruments of emission and reception work automatically without the disturbing presence of an observer, it would still be impossible to specify the reflecting power of the walls without a great amount of experimentation and complicated theory. Nevertheless, this is exactly what was done by the late Prof. Wallace C. Sabine, of Harvard University, who employed the human ear as the receiving instrument. Those who have made experiments upon the sensitiveness of the human ear for a standard sound will immediately doubt the possibility of making precise measurements by the same ear at different times, and particularly of comparing measurements made by one ear with those made by another. Nevertheless, Sabine attained wonderful success and was able to impart his method to pupils who carried on his work successfully, so that he was able to create the science of architectural acoustics and to introduce a new profession. Still, the skill that required three or four months to attain by Sabine's method may be replaced by a few minutes' work with the phonometer.

In order to avoid the influence of disturbing objects, the observer should take the phonometer to an infinite distance, which is manifestly impossible. The method employed was to get rid of all objects except a reflecting plane covered with a surface the coefficient of reflection of which could be measured. For this purpose the teeing ground of a suitable golf course was used. With the present instrument it can be determined in a few minutes, if there is no wind.

<sup>1</sup> From a Friday evening discourse delivered at the Royal Institution on June 10, 1921.

In 1890 I proposed to use a diaphragm made of paper, which should be placed, shielded on one side, at the point where the sound was to be measured. In order that the effect of the sound should not be distorted, the membrane, instead of having to do any work, as in the case of the diaphragm of the phonograph in digging up the wax, or in that of the micro-

mitted the use of fringes in white light, so that it was possible to use gas, incandescent, or arc light with excellent effect. A further improvement was introduced by the use of a thin plate of mica for the diaphragm.

To obtain the sensitiveness necessary to measure sounds of ordinary intensity, the property of resonance

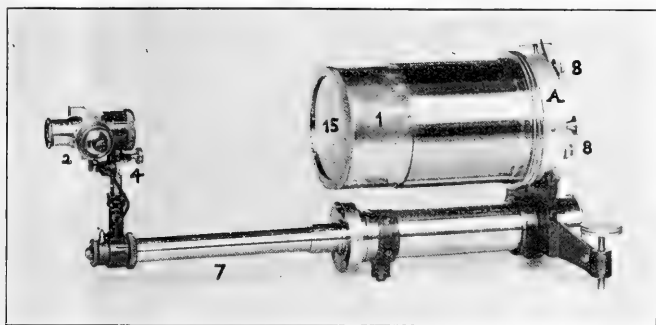

FIG. 1.—Phonometer. (Interferometer not shown.)

phone in compressing the carbon, was to be perfectly free, but was to carry a small plane mirror cemented on at its centre. In close juxtaposition and parallel with this was the plane side of a lens which, viewed in the light from a sodium flame, was to give Newton's rings, or interference fringes. Of course, when the

is employed twice—*i.e.* a system of two degrees of freedom is used. First, the plate resounds to a sound more strongly as it is tuned more nearly to it; and second, a resonator that can also be tuned is put behind the plate. The sound entering by the hole in the resonator is magnified by the tuning, and acts upon the

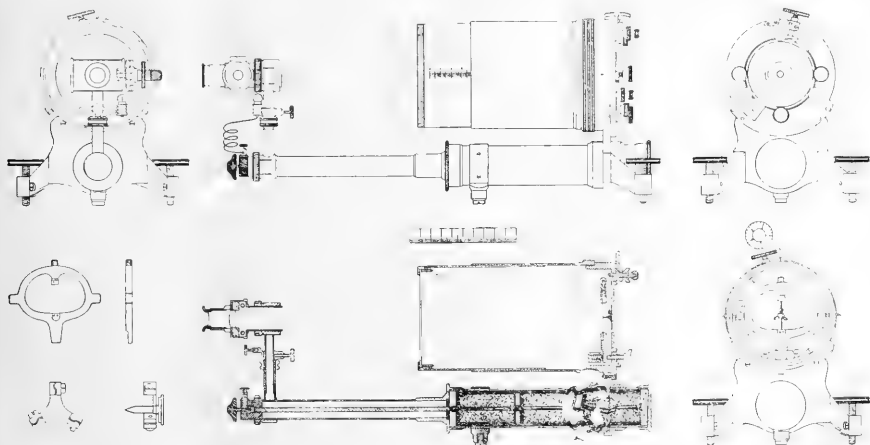

FIG. 2.—Parts of the phonometer.

sound falls upon the diaphragm the fringes vibrate rapidly and disappear from sight.

By the introduction of a Michelson optical interferometer, two of the difficulties of this instrument were overcome, namely, (1) that of adjusting the lens so that it would not strike the vibrating mirror, since the mirrors in the interferometer could be as far apart as one pleased; and (2), more important still, it per-

plate, which is also tuned. A graph can be plotted in which one co-ordinate represents the stiffness of the plate, or rather what may be called the mistuning, which is the stiffness lessened by the product of the mass by the square of the frequency. The other co-ordinate represents the corresponding quantity for the resonator, the stiffness of which depends simply on the volume into which the air is compressed, while the

effective mass depends on the dimensions of the whole, and its damping on the sound radiated from the mouth. It is then found that the tuning should not be such as to make the representative point occur at the middle of the figure, making both mistunings zero, but that both mistunings should be of the same sign and a certain magnitude, depending on the coefficients of damping of the two degrees of freedom of the coupled system. The mathematical theory is precisely that of a wireless receiver. The ultimate sensitiveness depends on the smallness of the damping of the plate.

The apparatus as it was built several years ago was mounted upon a heavy bronze stand, covered at the back by a heavy bronze cover to keep out the sound, while the three shafts turning the screws of the interferometer adjustment protruded through sound-tight fittings. Upon the front of the instrument a properly tuned resonator was attached, and at the side was a

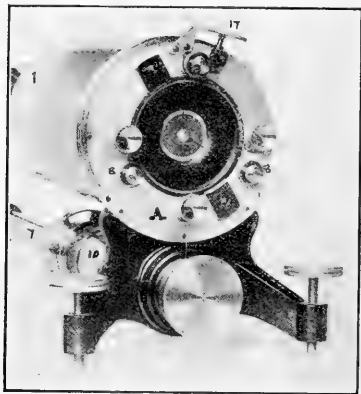

FIG. 3.—Front view of phonometer with annular opening.

small incandescent lamp with a straight, horizontal filament, an image of which was projected by a lens upon the first mirror of the interferometer. Upon this was focussed a telescope, giving in the reticule an image of the horizontal, straight filament, crossed by the vertical interference fringes seen with white light. In order to get these the plate must be in the proper position within a few hundred thousandths of an inch. The objective of the tuning-fork was carried by a tuning-fork which oscillated vertically, tuned to the pitch of the pure tone to be examined, and this, combined with the horizontal motion of the fringes, resulted in a figure of coloured fringes in the form of an ellipse. On slightly mistuning the fork, the ellipse could be made to go through all its phases, and when it was reduced to an inclined straight line its inclination was read off on a tangent scale. The amplitude of the compression of the air in the sound was then directly proportional to the scale-reading.

While the interferometer is still used for calibration, the movement of the diaphragm is recorded for actual measurements by a thin steel torsion strip carrying a concave mirror. A lamp with a vertical, straight filament is viewed through a telescope into which the small

mirror focusses the image of the filament on the reticule, and a magnification of from 1200 to 1500 is used, so that the sensitiveness is about the same as with the interferometer.

At first the only method of tuning was the clumsy one of changing the mass of the diaphragm by adding small pieces of wax. This was not capable of continuous variation. Now the diaphragm has been discarded and replaced by a rigid disc supported by three steel wires in tension. The disc is made of mica or aluminium, and is carried by a little steel spider containing three clamps to hold the wire. The tension is regulated by three steel pegs, one of which is controlled by a micrometer screw. The disc is placed in the circular hole through which the sound enters the resonator. This has the advantage of reducing damping very largely, and thus of increasing the sensitiveness enormously. The instrument now competes with the human ear, and can be tuned over two octaves or more.

This sensitiveness can be demonstrated by projecting the coloured interference fringes on a screen and singing faintly in a remote part of the room, when the fringes will disappear. Using the telescope end of the apparatus, the instrument will indicate the sound of a tuning-fork when one can scarcely hear it. It is obvious that the disc may be made the diaphragm of a telephone and thus increase its sensitiveness. In fact, Prof. King has used with great success such a telephone to record wireless messages. He has also invented another sort of tunable diaphragm composed of a stretched steel membrane with compressed air behind it, which enables it to be tuned continuously, but over a smaller range.

I now come to the source of sound—the phone. This has been reduced to a reversed form of the phonometer. The disc is driven by an interrupted or alternating current by means of electromagnets, and tuned like the phonometer. Its excursion is measured by a powerful microscope, and the emission of sound is known in absolute measure. It is now driven by a triode valve tube, in the manner suggested by Prof. W. H. Eccles, of Finsbury Technical College, London, for a tuning-fork. This has been worked out for me by Dr. Eckhardt at the Bureau of Standards in Washington.

The third part of the investigation involves a determination of the coefficient of reflection of the ground. The phone is set at a convenient height, and the phonometer at a convenient distance. Either is then moved along at a constant height and the varying deflections of the phonometer are read while the sound remains the same. Interference sets in between the direct sound and its image reflected in the ground, and the existence of a minimum is obvious to the most naive observer by the ear alone. The reflection of either grass or gravel was found to be about 95 per cent., while, with a most carefully deadened room, the walls of which were covered with thick felt, there was perhaps 20 per cent. reflection. The whole measurement at both ends and the transmission checks up with an accuracy of about 2 per cent.

With this apparatus all sorts of acoustical experiments may be performed. By attaching to the phonometer a long glass tube or antenna, it has been possible to explore all sorts of places, such as the

field within a horn or tube lined with an absorbent substance. The transmission of sound through fabrics, walls, and telephone booths may also be quickly examined. The instrument is used by psychologists and by telephone and acoustic engineers, and is of interest to navigators. An interesting by-product is an instrument for showing the direction of an acoustic signal in the fog. It has been called a phonotrope, on the analogy of heliotrope, which turns to the sun. It consists of two equal horns which bring the sound to the opposite sides of the disc. When the whistle blows, the band of light spreads out, and on turning the instrument it closes to zero when the sound is directly ahead. Thus at several miles the direction is given to within two or three degrees.

Finally, let us consider that mystery of sound, the violin, which has been studied by Prof. Barton of Nottingham, and by Prof. Raman at Calcutta. This may be described by the engineer as a box of

curious shape, made of a curious substance, wood, of variable thickness, with two holes of strange figure to let the sound out of the resonating box. The latter is actuated by a curious substance, catgut, made of the intestines of a sheep, and set in vibration by another curious substance, the tail of a horse. Yet from this wonderful box we get the most ravishing sounds, which affect profoundly the emotions of the most civilised. Yet the physicist reduces all musical instruments to combinations of resonators with strings, membranes, bars, plates, and horns. The mathematical theory of strings was given by Euler two hundred years ago, of bars and plates less than a hundred years, of resonators by Helmholtz and Rayleigh, and I have recently added a theory of horns which, while only approximate, works well in practice, and investigations are now being carried out by such methods on vowels and the violin.

### Biological Studies in Madeira.

By Dr. MICHAEL GRABHAM.

THE component islands and rocks on the Madeira Archipelago are separate foci of volcanic ejecta in the abyssal oceanic depths, and the level of the Atlantic waters might be lowered 100 fathoms without merging them in a common connexion. Of the 170 forms of Testacea existing in the region, only five species are distributed throughout the Island group, and such evidence is adversely copious and conclusive as to the theory that the Madeiras are a surviving relic of a former continent.

The fossil shells now lifted 1500 ft. above the sea level show an upper Miocene association, but the massive piling up of volcanic matter in countless reiteration of eruption and age-long intermission began long before the fossil shells were living creatures on a Miocene shore.

Examination of a fossil leaf-bed, containing examples of the specific insular flora buried 120 ft. beneath a variety of strata and capped by a thick deposit of white trachyte, shows that the trachyte rock has almost disappeared under the slowly working forces of erosion and disintegration. From this is adduced the enduring quality of the trachyte steps and gateways of Funchal, which have been exposed for two centuries, with little evidence of decay, to the same influences under which the thick leaf-bed cap has vanished. Thus we need set no niggardly limit to the time requirement for the establishment of the specialised forms of life developed and buried ages before the trachyte capped the successive strata in a flowing stream of lava.

The Archipelago came to us 500 years ago, in the dawn of navigation, ready made, already well worn into characteristic scenery, with the local flora stabilised, the discovery being due to the erratic drifting from its course to the West African coast of a crazy vessel of Prince Henry the Navigator. An ancient building is regarded locally as the traditional home of Christopher Columbus, who married the Admiral Peristrello's daughter, and was, no doubt, inspired for

his western enterprise by watching the sea currents and the evidence they brought of land and life beyond the horizon.

The agencies of transport and distribution we know; the sea currents are the same; the same winds prevail; the same birds come and go, though it may be difficult to believe that the presence of the Testacea in 170 forms and the Coleoptera in 700 species has been due to fitful and accidental influences. It is difficult, though the rain falls now as formerly, to point to a single rock or ravine as having appreciably lessened or deepened, though the storms of every winter carry thousands of tons of material to the ocean bed.

The completeness with which the natural orders exist in Madeira and the prevalence of specific forms make it less bewildering to believe that these forms of life were brought to us in pots from the Garden of Eden than to trace their descent from primeval forms which no longer survive. The shells can be compared with fossilised ancient types, but the flora has no such satisfactory appeal.

The name "Madeira" is derived from the hard wood known as *Materia*; *Coniferæ* are not prominent in the native flora. I have introduced *Pinus Insignis*, *Cupressus Macrocarpa*, and other species, while the seeds of *Persea Indica* have been sent abroad with the view of enlarging the range of the alligator pear-tree by grafting.

In conformity with other oceanic centres, Madeira has numerous examples of orders with a single genus and of genera with a single species. The striking fruticose echiums illustrate stabilised specific forms, and show how a new bee has effected an important hybridisation by which perennial characters were conferred on a plant of biennial life-limit, the helicoid flowering cymes, normally 2½ inches long, being prolonged into growths 7 or 8 feet high.

The Carniolan bee concerned in this hybridisation at first abstained from fruit eating, but it speedily blended with the local black bee and became a vine-

yard pest. Similarly many attractive flowers have become in Madeira pernicious pests; such are *Oxalis*, *Eupatorium*, *Scenecio*, and *Freziera refracta*.

Madeira could, however, be made a focus for the dissemination of plants of economic value. The gourd, *Sechium Edule*, has remarkable food value, and is very potent in fat utilisation. The plant shows a singular development of the seed-surrounding flesh into the permanent stem growth of the climbing plant. During the stress of war, when German U-boats wantonly destroyed everything and the Island food was restricted to local resources, the potency of the *Sechium* was realised, and on several occasions the sullen apathy of incipient starvation was awakened into reviving animation under its influence. The gourd was also utilised during the time of construction of the Panama Canal, when the Italian labourers had to be coerced to use a sufficient fat ration in their food in order that they might equal the output of their Canadian fellow-labourers.

Another valuable plant is *Lycopersicum cerasiforme*, which provides an agreeable tomato food with important antiscorbutic qualities. In the Salvage Islets there is also *Monizaia Edulis*, the carrot fern of Madeira, with a species of the apterous *Deucalion*, otherwise known only on the Madeira rocks, side by side with the Canarian *Samphire astadanaya*; this seems to establish a balancing correlation or agreement between the botanic and entomological features of the two island groups.

An interesting illustration of sterility yielding to the introduction of a new pollen is afforded by a species of the Bignoniaceae jacaranda, while the sterility of the banana and the complete loss of fertility in the fruiting *Solanum guatemalense* show, on the other hand, how we are constantly curbing the superabundant seed growth of valued sub-tropical fruits, such as the custard apple and the loquat, which in the fruit-vacant months of Northern Europe should flood British markets both in perfection and profusion.

Many introduced plant pests, such as *Peronospera* and *Oidium*, have been brought under control, and even the *Phylloxera vastatrix*, which destroyed the Madeira vineyards before its life-history was made out, has become almost negligible in its depredations; thus the wine of Madeira has returned in adequate and superabundant supply. The Argentine ant may be credited to some extent with restraining the activity of the *Phylloxera* aphid. In view of the almost certain invasion of the British Islands by this pest, the Board of Agriculture should issue and circulate the American official booklet on the subject, together with a reprint of a paper read by me before the British Association two years ago. No less than 47,000 of these ants have been found engaged in draining a single lemon tree of its vitality; but various agencies of restraint are now employed in the orange and coffee plantations. The common flea and the house-fly do not seem to have abated under the domination of the *Iridomyrmex*.

The winged ant-queens suffer deaëlation after mating, and, discarding the cares of motherhood, they issue forth with the workers and found new colonies wherever conditions invite. The intelligent ingenuity of the ant and its tenacity of purpose in the face of obstacles is very remarkable.

As regards oceanic research, organised exploration of the ocean flora and deep-water biology is urgently necessary in the national interest. This investigation is a part of our responsibility in Imperial expansion; a second *Challenger* expedition is long overdue, and could be accomplished at a comparatively small cost.

The fisheries of Madeira provide several novel specimens. The Sherny, *Polyprion Cernier*, freshly brought from the deep sub-tropical water of the Madeira district, is typical of the warmer seas, though occasionally seen farther north. This is the wreck fish of British nomenclature, so known from its association with floating timber logs. The early life of the fish is passed in the sunlit surface waters, but the proper habitat of the full-sized creature, 100 lbs. in weight or more, is in the open sea at the enormous depth of 2000 or 3000 ft.

The fish, when brought to the surface from that profound depth, so distends at the removal from the vast pressure below that it emerges from the water like a cork or bladder, with its stomach forced through the capacious mouth and the eyes protruding in front of their sockets. No explanation is known of the conditions which prompt the fish to descend from the surface warmth into the cold darkness of the abyssal region, where only the larger examples are to be found. That the sea is nowhere azoic is shown by the plump and well-fed condition in which the Sherny comes to the surface. Its dull colouring, which is shared by the *Aplurus* and *Promethus Atlanticus*, contrasts surprisingly with the brilliant hues of *Sebastes*, *Scorpena*, and *Lampris*, which also live in the depths, though rarely in close association with their sober-tinted brethren. The Sherny has a large air-bladder firmly attached to the spine, but knowledge of the function of this organ is very imperfect. The regulation of submersibility by a voluntary act of filling, emptying, or compressing is probably only a subordinate physiological function, for the structure of the bladder is suggestive of pulmonary functions, and its firm attachment to the spine and its prolongation upwards to a cerebral connexion with the organ of hearing, seem a sure indication of the use of the organ as a resonator in the interpretation of weak sonorous vibrations. The air-bladder, nevertheless, is totally absent from the *Aplurus* and many other fishes.

Some of the fishes swimming near the surface are believed to have their air-bladders charged with nitrogen, but extensive observation does not confirm the current idea that in deep water oxygen is the inflating gas. The consumption of oxygen by fish is small, and the standard of respiration in oceanic fish of deep water is low; the heart-beat in the *Polyprion* will continue many hours after every other sign of life has ceased. Stationary traps are necessary for the investigation of the abyssal forms of life.

The surface plankton is abundant, but the contracted empty stomachs of some of the deep-sea fish is evidence against the idea that much food is dissolved in deep-sea water. The *Aphanopus Carbo* is a voracious monster which abounds in the lesser depths, and ranges freely among the inexhaustible invertebrates of those regions.

During a series of observations on earth-currents in deep-sea cables, strange effects were noted which were



found to be due to a submarine earthquake which broke up many miles of the ocean floor. The occurrence may be compared with a similar commotion which destroyed an important fishery in the sub-tropical waters of the United States.

A full and comprehensive appreciation of sub-tropical ichthyology is necessary to indicate the vast and interesting variety of the fauna and the intrinsic charm

of scientific research. It is the duty and interest of the community to discover the potential genius and place him where he can accomplish that for which he is fitted, unfettered by the suppressing restrictions of a false communistic socialism or cramping of individual effort.

Magna opera Domini exquisitae omnes  
voluntates ejus.

## Ten Years of X-ray Crystal Analysis.

By DR. A. E. H. TUTTON, F.R.S.

A SPECIAL number of *Die Naturwissenschaften*, entitled "Zehn Jahre Laue-Diagramm," was issued on April 21, forming Heft 16, 1922, which contains eight articles by authors who have contributed to the subject of X-ray analysis on the continent since its first inception by Dr. M. von Laue, among whom may be mentioned Drs. Friedrich and Knipping, who collaborated with Dr. von Laue in the first discovery, Prof. Debye, and Prof. Niggli. Probably the article of deepest interest to the general reader will prove to be that of Dr. Friedrich, who gives an account of the circumstances in the year 1912 in Munich when the first discovery was made. To the present writer, who was himself in Munich in the summer of that same remarkable year, this memoir is of fascinating interest. It has to be remembered that the scientific coterie at that time forming the professorial staff of the University, Museum, and Institute, included Prof. Röntgen, the generally recognised discoverer of X-rays (although their production had for some time previously been almost a daily occurrence in the private laboratory of the late Sir William Crookes); Prof. von Groth, the founder and editor of the *Zeitschrift für Kristallographie* and the doyen of crystallographers, whose brilliant lectures on crystal structure and optics attracted students from all over the world; Prof. Sommerfeld, who had carried on the tradition of X-ray physics bequeathed to him by his predecessor Boltzmann, and also extended the work of Haga and Wind, and of Walther and Pohl on X-radiograms and the general physics of X-rays; Prof. Ewald, who had studied the behaviour of long electromagnetic waves with space-lattices; and Dr. von Laue, who had specialised largely on the interference phenomena of ordinary optics. It was among this strong combination of crystallographers, X-ray specialists, and diffraction (grating) opticians that the inception of the attack on crystals by X-rays had its birth.

During a conversation between Laue and Ewald, the former raised the question as to how electromagnetic waves would behave which were small compared with the grating constants, and from his optical experience, he suggested that diffraction spectra should be produced. The order of the space-lattice cell dimensions of crystals was already known to be about an Ångström unit ( $10^{-8}$  cm.), from the density and molecular weight of the crystal and the mass of a hydrogen atom. The work of Sommerfeld and of Walther and Pohl had led us to expect that the order of dimensions of the wave-length of X-rays would be about one-tenth of this ( $10^{-9}$  cm.). Consequently Laue suggested that the conditions should be particularly favourable for the

origination of interference phenomena on the passage of X-rays through crystals.

The discussion was continued in the common room, and taken up by the whole, deeply interested coterie, and Friedrich, who was at the time acting as Sommerfeld's assistant, declared himself, with youthful enthusiasm, ready to test the idea practically. He secured the assistance of Knipping, who had more spare time at his disposal, and together they set up the now famous arrangement of X-ray bulb, leaden screens with slits for ensuring the exit of a definite beam of X-rays, simple goniometer carrying the crystal, and photographic plates to receive the expected radiations. At the first attempt the sensitive plates were only arranged parallel to the primary beam of X-rays, as any effect expected appeared likely to be of the character of secondary rays from the crystal, and it was only on repeating the exposure with a photographic plate arranged behind the crystal, perpendicular to the direct beam, that the first Laue radiogram with a crystal of zinc blende was obtained, after several hours of exposure.

Friedrich describes how excited and delighted he was when, alone in his working room at the Institute late that night, he saw the spots appear on the plate under the influence of the developer, due to the deflected X-rays, now known to be reflected from the planes of atoms within the crystal, the planes of the atomic space-lattice. Next morning he went early to show the negative to Knipping, and together they hastened to Laue and Sommerfeld, who were both naturally equally interested and delighted. Prof. Sommerfeld at once excused his assistant from his ordinary duties, so that he might go ahead with further experiments. Both Profs. von Groth and Röntgen, to whom the result of the experiment was at once communicated, supplied materials and gave valuable advice. A much better and more accurate apparatus was erected, including a good goniometer for the exact adjustment of the crystal (which is particularly necessary), and the excellent X-radiograms of zinc blende, quartz, rock-salt, and other crystallised substances, now so well known were obtained as the immediate results.

Dr. Knipping directs special attention in his article to the remarkable work of Siegbahn, who worked with an evacuated apparatus, so as to exclude air absorption of the X-rays, and measured the wave-lengths of the "softer" long wave-length portion of the radiation, eventually discovering and measuring rays as long as ten Ångström units. Compton, it will be remembered, at the other extreme, has measured X-rays ( $\gamma$ -rays

from radium) on the short wave-length side as short as 0.02 Ångström units. Hence, the X-ray spectrum now known comprises waves of all this great range of wave-lengths. It will also be remembered that other researches, such as those of Lyman and Kurth, Mohler and Foote, and Richardson and Bazzoni, have introduced us to rays, termed the K, L, M, and N series, derived by radiations from carbon, oxygen, iron, copper, potassium, sodium, magnesium, and molybdenum, which have wave-lengths ranging to 375 Ångström units, thus bridging over the gap between the shortest ultra-violet rays and X-rays.

Prof. Niggli's contribution offers a survey of the substances the crystal structure of which has now been ascertained by the various X-ray methods of Laue, the Braggs, Debye and Scherrer, and Hull, including a table of the absolute dimensions of the space-lattice cells resulting from the Bragg spectro-metric measurements. His concluding remarks are

well worth quoting (so far as is possible in a translation from the German), especially when it is remembered that Prof. Niggli has now taken over from Prof. von Groth the editorship of the *Zeitschrift für Krystallographie*. "By Laue's discovery crystallography not only obtains a new method of investigation, but experiences a new 'liveliness' in almost every one of its branches. Most especially are we mineralogists glad that our colleagues of the sister sciences now bring to the crystal an entirely new attitude of mind and interest than formerly, for only by the combined and simultaneous labours of all can further research move along right lines."

With these words of Prof. Niggli we must all agree, and it would appear that the sentiment is now so universally accepted and recognised that the future is bright with hope for a progress during the next decade as glorious as that which is now recorded at the termination of ten years of X-ray crystal analysis.

### Obituary.

PROF. J. C. KAPTEYN, FOR. MEM., R.S.

JACOBUS CORNELIUS KAPTEYN was born at Barneveld, Holland, on January 19, 1851. He studied at Utrecht from 1869 to 1875, and was then appointed an observer at Leiden Observatory, where he remained for two years. In 1878 he was appointed professor of astronomy and theoretical mechanics at the University of Groningen. He was in the unusual position of an astronomical professor without an observatory, and he immediately applied to the Dutch Government for the means to equip a students' observatory; he mentioned in particular a 6-inch heliometer as desirable. The application, however, was unsuccessful, and for a few years his lectures monopolised his attention. Then, finding that he had time to spare and no instruments, he began to look about for some useful astronomical work of a computational kind that he could carry out. Circumstances soon brought a task well fitted to his tastes.

Photography had been revolutionised by the introduction of the gelatine dry plate about 1880, and its astronomical possibilities were soon exemplified by the successful photographs obtained of the comets of 1881 and 1882. In the latter case Sir David Gill assisted the local photographers by letting them strap their camera to an equatorial, with very successful results; he was impressed by the number of faint stars that were visible on the plates, and the idea of a southern photographic *Durchmusterung* quickly matured in his mind. He found a willing collaborator in Kapteyn, who volunteered to conduct the measurements and reductions at Groningen. Funds were collected from various sources; the Government Grant Committee of the Royal Society voted 300l. in each of the years 1885 and 1886; this was, however, stopped in 1887, it is believed from the notion that the Astrographic Catalogue, which was then inaugurated, would obviate the need for the *Durchmusterung*. If that was the idea, subsequent events have proved it to be incorrect. The Astrographic Catalogue is still far from completion, while the *Durchmusterung* has been available as a standard work for a quarter of a

century. It might have been made more perfect but for shortage of funds: the plates admitted measurement to seconds of arc, but in practice this was limited to tenths of minutes. Moreover, it was only carried to declination 18° S., instead of to the equator. With a view of shortening the reductions, Kapteyn devised an ingenious measuring instrument, which was practically a small equatorial placed in the position, relatively to the plate, occupied by the centre of the camera lens, the principle being that, since the rays through this point suffered no bending, the star-images, viewed from here, have the same configuration as the stars themselves. Hence right ascension and declination could be read from the circles.

The whole work occupied thirteen years, nearly double the original estimate, but the time was spent ungrudgingly by Kapteyn, and the close examination and discussion of the results brought to light many interesting facts, such as the change of colour-index with galactic latitude, the galactic stars being bluer than the non-galactic ones. It was also found by careful counts that there was no sensible difference in the number of stars recorded at the centres of the plates and near their edges. Several cases of light variation and of rapid proper motion were also found. The question of photographic stellar magnitudes was still in its infancy, but a simple formula was found,  $\text{mag.} = B/(C + \text{diam.})$ , B and C being constants for the plate; as these are printed, it is possible to recover the diameter of each star.

Kapteyn was elected an associate of the Royal Astronomical Society in 1892, and received its Gold Medal in 1902 in appreciation of his work on the *Durchmusterung*. This was, however, only one of the numerous researches that he undertook to investigate the structure of the sidereal universe. He saw the need for increased knowledge of stellar parallaxes. In 1886 he investigated the parallaxes of forty-five stars by the method of meridian transits (since found to be less accurate than the photographic method), and endeavoured to secure that the astrographic plates should each have three exposures at dates of maximum parallactic displacement. This was not

carried out, but Prof. Donner tested the method at Helsingfors, sending the plates to Kapteyn for measurement; he deduced parallaxes for 246 stars, but realised that direct parallax measures were insufficient to gauge more than a small fraction of the universe. He then set to work to deduce distances from the proper motions, incidentally giving a new method of deducing the solar apex by making the sum of the resolved proper motions in the direction of the antapex a maximum, that in the perpendicular direction zero. From this work he deduced formulae connecting parallax with magnitude and proper motion, which, with some modifications, have been found very serviceable. To the end of his life he entertained a certain distrust for spectroscopic parallaxes, though this scarcely seems to be justified.

In the course of his studies on proper motion Kapteyn made the notable discovery of the two star-drifts, which has played a great part in all subsequent work on stellar motions. It has been interpreted in various ways—as the separate motions of two interpenetrating star-clouds—as radial motions, respectively inward and outward, of stars oscillating through the centre—as rotational movements in opposite directions about the centre. Kapteyn himself favoured the latter view. He saw the necessity of obtaining more statistics about the faint stars, and planned the "Selected Areas" uniformly distributed over the sky; in these restricted regions all available information should be obtained about all the stars down to the faintest visible; from the results statistics for the whole sky could be formed. One of his last wishes was that astronomers should continue to investigate these regions after his death, and his wish will doubtless be realised.

Of late years Kapteyn spent a good deal of time at the great American observatories, and took the keenest interest in the physical investigations there in progress. His last paper on the configuration and motion of the stellar system was published in the *Astrophysical Journal* a few days before his death.

A. C. D. CROMMELIN.

#### JOHN WARD.

THE National Museum of Wales and the cause of archaeology in the Principality have sustained a serious loss by the death, on June 18, of Mr. John Ward. Born in 1856 at Derby, he started in life as a pharmacist, but all his leisure time was devoted to the examination of old buildings and other objects of antiquarian interest. It was this work which in 1893 led to his appointment as curator of the Cardiff Municipal Museum in succession to the late Mr. John Storrie. Here he carried on the same lines of research, which resulted in the publication of several papers in the Transactions of the Cardiff Naturalists' Society and the *Archæologia Cambrensis*, of which probably those on the Roman fort at Gellygaer and the St. Nicholas chambered tumulus were the most important. In addition he wrote for Methuen's series of "Antiquaries' Books" two volumes on "The Roman Era in Britain," and "Romano-British Buildings and Earthworks."

He naturally took a deep interest in the establishment of the National Museum of Wales, and when the Cardiff Museum was absorbed in that Institution he was appointed to the dual post of Keeper of its Archaeo-

logical Department and Curator of the Cardiff Collections; these duties he discharged with energy and success until failing health necessitated his retirement two years ago.

A conspicuous service which Mr. Ward rendered to the Museum was the accumulation of a large series of obsolete and obsolescent appliances from farms and rural homesteads. These were arranged by him in a temporary "Exhibition of Welsh Byegones," for which he prepared a valuable and interesting handbook. The book found a ready sale and was soon out of print. It was his intention (now, alas, impossible of accomplishment) to prepare an enlarged edition of it, illustrated by drawings from his facile pencil.

One of his striking characteristics was the exquisite finish of every piece of work which left his hands. A conspicuous example of this is the series of models illustrating geological structures, which gained him a silver medal at the Paris Exhibition in 1900.

Mr. Ward had been for many years a Fellow of the Society of Antiquaries, and in 1918 the University of Wales conferred upon him the honorary degree of Master of Arts. Unfortunately the state of his health prevented him from attending the graduation ceremony. He was a keen and enthusiastic student, a man of enlightened views on Museum policy, a loyal colleague, and a warm friend.

W. E. H.

#### SIR GEORGE R. PARKIN, K.C.M.G.

BORN in New Brunswick in 1846, George Robert Parkin was one of many notable men whom the Maritime Provinces have given to the Empire; but few have had so clear a vision of what Empire means, or have devoted their lives with such ardour to its service. Life in Lower Canada in his early days was strenuous. Farm work, study when body and brain were tired, a meagre living earned by teaching in the common schools, a B.A. degree secured by the practice of severe economy, the Douglas gold medal for proficiency in science. In after days Parkin attributed his intellectual awakening to the influence of a teacher who had been a pupil of Agassiz, although his own bent, after he left the University of New Brunswick, was for the humanities. In 1874-75 he was so fortunate as to spend a year as an unattached student at Oxford, where his eloquence gained for him the office of secretary to the Union at a time when Asquith, Milner, and Thomas Raleigh were its leading speakers. But most notable of the friendships consolidated at Oxford, although it originated through correspondence before he left Canada, was that with Edward Thring, the strength of which is evidenced by the request in Thring's will that Parkin would write his biography. In 1875 he returned to Canada as headmaster of the school at Fredericton.

Parkin was a great talker. His ebullient enthusiasm overflowed in speech; and, just as his enthusiasm was the product of fervid conviction, so also was his talk sincere. He had no conscious mission. His advocacy, in consequence, was irresistible. In 1889 the Imperial Federation League induced him to make a tour through Canada and Australasia. That he should be chosen by the Rhodes Trustees, in 1902, as their first organising secretary, was a proof that it was generally recognised

that, for such a position, his qualifications were unique. Before he resigned this office in 1920 he was able to boast that he had visited every State in the Union and spoken in every University of the Empire. Universities will hold his name in remembrance, not the least of the causes for their gratitude being the paper which he read to the Congress of 1912 on "The Establishment of a Central Bureau; its Constitution and Functions." Re-reading this paper with a knowledge of the developments which have taken place since it was written,

one is impressed with the practical character, and even the prescience, of the proposals it contains.

WE note with regret an announcement in the *Chemiker Zeitung* of June 15 that Prof. Wilhelm Wislicenus, director of the Chemical Institute of the University of Tübingen, died on May 8, aged sixty-one years. Prof. Wislicenus was one of the foremost chemists in Germany, and his researches on organic chemistry and stereochemistry are well known.

### Current Topics and Events.

At a meeting of the Council of the Royal Society of Arts on June 29, the president, H.R.H. the Duke of Connaught and Strathearn, presented the Albert Medal of the Society for the present year to Sir Dugald Clerk, "in recognition of his important contributions, both theoretical and practical, to the development of the Internal Combustion Engine."

THE James Scott Prize of the Royal Society of Edinburgh, established in 1918 for a lecture or essay on the fundamental concepts of natural philosophy, was presented on June 5 to Prof. A. N. Whitehead for his lecture entitled "The Relatedness of Nature."

PROF. L. BAIRSTOW has been elected chairman of the Royal Aeronautical Society for the year 1922-23 in succession to Lieut.-Col. M. O'Gorman, whose period of office terminates on September 30 next.

At the annual meeting on June 27 of the Research Defence Society, Sir Walter Fletcher, secretary of the Medical Research Council, gave an address on the work that is being done, by medical research, for the advantage of the life of the nation. He took two instances: the study of the vitamins in food, and the action of pituitary extract. Both are good examples of work already fruitful, but not yet complete. But they are only two examples, taken almost at random, from a great wealth of material. It would need a big book to describe all that has been done of late years, under the Medical Research Council, for our health and welfare, and it is strange that there should be members of the House of Commons opposed to the spending of public money on this work. The opposition, of course, is to the necessary use of experiments on animals. The spirit which goes by the name of anti-vivisection was described as one of the enemies of the people. Happily, in this matter, we have all the help which the Government can give to us.

It is reported in the *Times* that Mr. T. W. Bagshawe and Mr. M. C. Lester have returned to England after an adventurous wintering in the Antarctic. Landed at Andvord Bay on the west of Graham Land (lat. 64° 45' S.) by a Norwegian whaler in December 1920, Messrs. Bagshawe and Lester hoped to be able to undertake some exploration in the interior of Graham Land; but the site of their base was ill-chosen for

this purpose, and they were unable to do any survey beyond the immediate locality. Their work amplified the rough surveys of the *Belgica* on this coast in 1898. Meteorological observations were taken throughout the winter. From Mr. Bagshawe's account of the adventure it would appear that he and his companion were most inadequately supplied with stores and equipment for an Antarctic winter, having to improvise a hut from their boat with the help of canvas and packing-cases. For food they wisely relied largely on seals and penguins. Fortunately the west side of Graham Land has a relatively open winter climate. The men were rescued by a Norwegian whaler from Deception Island in December 1921.

An exhibition of Egyptian ornaments, tools, and carvings belonging to the First Dynasty, and of numerous papyri of different ages, the fruits of a season's work by the British School of Archaeology in Egypt, under the direction of Prof. W. M. Flinders Petrie, will be open at University College, Gower Street, until July 29. Admission is free and without ticket.

THE twentieth session of the International Congress of Americanists will be held in Rio de Janeiro on August 20-30 next, under the presidency of Dr. Joao Teixeira Soares. The arrangements are in the hands of a strong local committee. As the celebration of the centenary of Brazil's independence begins on September 7, it is anticipated that there will be a large attendance. The subjects which are to be discussed at the congress are the origin, history, languages, customs, and religions of the native races of America; the ancient monuments and archaeology of America; and the history of the discovery and European occupation of America. At the close of the congress arrangements will be made for excursions to the States of Minas Geraes, St. Catherina, Espirito Santo, and São Paulo. Members of the congress will be afforded an opportunity to return by way of Para, where there is, in the museum, the collection of ancient pottery from the island of Marajo, which is of great interest to students of American archaeology. Arrangements have been made by the Royal Mail Steam Packet and Nelson lines for members of the congress to travel at reduced rates. Information

respecting the congress may be obtained from the Secretario Geral, XX Congresso de Americanistas, Sociedade de Geographia, Praça 15 de Novembro, No. 101, Rio de Janeiro.

SOME interesting points in the work of officials connected with scientific and technical bodies, especially in relation to the scientific and technical press, were raised in an address on the duties of secretaries, delivered by Mr. P. L. Marks at a meeting of the Circle of Scientific, Technical, and Trade Journalists on May 30. There are few men gifted with the power of presenting scientific knowledge in an easily assimilated form, and it is here that a really competent secretary reveals itself. Editors are busy men, often with a wide but not a detailed knowledge of scientific subjects, who require information conveyed within a small compass; and if a secretary, in issuing matter to the press, can select certain journals for individual treatment, providing them with matter closely allied or linked to their respective fields of operations, his efforts will not be vain. This applies particularly to bodies the aim of which is the popularisation of science. The ideal secretary must be able to take a wide view and sanction some departure from the limits of absolute scientific truth, if essential to simplicity and popular appeal. While rejecting fallacious statements—involving inaccuracy arising from ignorance rather than an effort after simplicity—such as are apt to creep into daily non-technical papers, it is not necessary to adhere to the standard rightly demanded in scientific transactions. With regard to secretaries who exercise editorial functions in connexion with their societies, Mr. Marks inclines to the view that no radical alteration in contributions or discussion should be permitted. Nevertheless we think it advisable in the interests of a society that its transactions should not contain statements that are manifestly incorrect or absurd, or in conflict with its policy. In general the authors of such remarks are open to correction, if tactfully conveyed. A secretary of a scientific body may not receive high remuneration, may not even enjoy the esteem and appreciation he deserves, but he has the knowledge that by his work he is shaping the scientific destiny of the nation.

WITHIN recent years most of the leading industries have founded Research Associations, and in 1919 the Council of the Institute of Brewing decided to make provision for investigating problems of a general character in the brewing and allied industries. To obtain the necessary funds for carrying out the scheme a new class of members, known as Research Fund Members, has been created. These members consist of firms who are invited to join the Institute at a minimum annual subscription of 10 guineas. At the end of 1921, the total subscriptions amounted to nearly 6000*l.* per annum, so that the scheme is now well in being. Two reports have already been issued, and particulars are given of the investigations so far carried out in connexion with hops, barley, and timber. An account is given of the experiments on breeding new varieties of hops at the South Eastern

Agricultural College, Wye, and their testing on a commercial scale at the East Malling Research Station, under the direction of Mr. E. S. Salmon. Photographs and a detailed description of the kilns erected by the Institute at Beltring, Kent, for investigating the various factors involved in the drying of hops are also given in Report II. Manurial experiments on hops are being carried out at Chilham and Horsmonden by Mr. F. Ivo Neame and Mr. T. I. Nicolson respectively, while the chemical investigations are being conducted, under the direction of Dr. F. L. Pyman, at the College of Technology, Manchester. With regard to barley it is intended to make a systematic study of barley and malt from the agricultural, botanical, chemical, and physiological stand-points, and arrangements have been made for field trials, under the direction of Sir John Russell, of the Rothamsted Experimental Station, on farming conditions in East Suffolk, Lincolnshire, Somerset, Essex, Yorkshire, Norfolk, Shropshire, Wiltshire, and the East Lothians. Trials are also being made at the Rothamsted and Woburn Experimental Stations. Mr. H. F. E. Hulton has drawn up a report on the relation of the nitrogenous matters in barley to brewing value, while botanical and chemical investigations on timber for casks, with special reference to American oak, are being carried out at the Imperial College of Science and Technology, under the direction of Prof. P. Groom and Prof. S. B. Schryver, respectively.

At the meeting of the Royal Statistical Society on June 20, a paper was read by Mr. J. W. Verdier dealing with the statistics of shipping casualties and loss of life at sea. Discussing the occupational risks run by seamen, the author gave comparative estimates, based on the recorded deaths by accidents in the five years ended 1913. The yearly death-rate among seamen was 4.05 per thousand employed, compared with 1.56 for underground workers in coal mines, and 0.59 for railway servants. It is estimated that the number of deaths per million man-hours of employment was 0.97 for seamen, 0.68 among underground workers in coal mines, and 0.20 among railway servants. Mr. Verdier also compared the accidents involving deaths of passengers on steam vessels with those on railways. Assuming that, in the foreign trade, sea passengers are at sea for twenty days on the average, and that railway passengers (excluding season ticket holders) are on the train for about an hour, then, in the period about 1900, the railway passengers' deaths were 0.12 per million passenger-hours, while the sea passengers' were 1.5, or more than twelve times as great. In the period about 1910, the railway passengers' deaths were about 0.1 per million passenger-hours, and the sea passengers' 0.3, or three times as great, showing that there has been a general progress towards safety.

THE address prepared by Sir Robert Hadfield for the Sheffield Association of Metallurgists and Metallurgical Chemists last October has been published under the title of "The Work and Position of the

Metallurgical Chemist," and is illustrated by a number of plates. The address covers a very wide field, the history of metallurgical research being surveyed, with special reference to the part played by Sheffield workers. This is brought into relation with the general history of science, and with the early work of the Royal Society in establishing the experimental method of investigation. The international character of metallurgical research is exemplified by a description of the new Japanese Institute for Steel Research, just opened at Sendai under the direction of Prof. Honda. The speaker's own work is dealt with, particularly in the application of manganese steel to the purposes of the war. This aspect of metallurgy was illustrated by the exhibition of a very fine series of specimens of this alloy as employed in the arts of peace and war. The exhibition also included specimens of the author's other technical work, and books and other objects of historic interest. The plates are finely produced, and are of great interest.

ACCORDING to the June issue of the *Decimal Educator*, the official organ of the Decimal Association, the Association proposes to concentrate its efforts for the time being on securing an alteration of the value of the pound weight from 454 to 500 grams, that is, half a kilogram. The ounce of 16 to the pound would in the first instance be retained, so that 4 ounces would be 125 grams. The new ton would be 2000 new pounds, equal to the metric ton and a little more than 1.5 per cent. greater than the present ton. All denominations between the pound and ton, such as hundredweights, quarters, and stones of all kinds, would be eliminated and intermediate weights expressed in pounds. This decision will not interfere in any way with the movement, which has the support of bankers and chambers of commerce, for the change of the value of the penny to one-tenth of a shilling.

THE Review of the work of the Rockefeller Foundation for 1921, compiled by the president, George E. Vincent, has just been issued. Grants have been made to numerous educational institutions for campaigns against hook-worm disease, malaria, yellow fever, and tuberculosis; for the promotion of the training of nurses; for libraries, fellowships, and other purposes. A sum of more than seven and a half million dollars has been expended on the world-wide activities of the Foundation.

THE Ministry of Agriculture, Industry, and Commerce of Brazil has just published the first number of a new journal, *Revista Mensal de Meteorologia*, which will be devoted to meteorological interests in that country. The review will be divided into (a) memoirs, etc.; (b) notes, reviews, and critiques; (c) bibliography; (d) notices; (e) papers by the Director of Meteorology. The first number contains an article on the applications of meteorology to everyday life, the report of the Director of Meteorology from June to December 1921, the reorganisation of

the meteorological service in the Minas Geraes province of Brazil, notes from foreign sources, and a number of reviews, among other interesting features.

THE firm of Messrs. Pastorelli and Rapkin, Ltd., of 46 Hatton Garden, London, has forwarded to us a list of thermographs and hygrographs. The instruments are of two types, for meteorological observers and a stronger make for factory work, such as fruit preserving and drying, cold storage chambers, dye works, wall paper printing, and other branches of industry. Two patterns are recommended—the Peandar and the Edney. The former is suggested for meteorological observers and has a small, stem-divided thermometer fixed near the thermometric coil, so that the readings shown by the self-recording instrument can be compared and if necessary readjustment can be made. A pattern of the Edney is adapted as a hair hygrometer which records directly the percentage of humidity by the alterations in the length of a string of human hair. The dry and wet bulb thermometers, known as Mason's hygrometer, have long maintained their utility. The instrument maker would improve the hygrometric results if he contrived that a good flow of air should be driven over the wet bulb, a consideration of growing interest on both sides of the Atlantic.

WE have received from the City Sale and Exchange, 81 Aldersgate Street, E.C.1, the catalogue of the Koristka microscopes and accessories, for which they are sole British agents. Several different types of microscope stands are listed, from simple students' models to instruments suitable for research work and photomicrography. A travelling portable folding microscope is also supplied, which, with objectives, etc., weighs less than 7 lb. and folds into a leather case measuring  $7\frac{1}{2} \times 5 \times 7$  in. Photomicrographic cameras, warm and detachable mechanical stages, dark-ground illuminators, microtomes, hand lenses, and other accessories are also included in the catalogue. A complete series of apochromatic, semi-apochromatic, and achromatic objectives are manufactured by the firm. The Koristka Co. has a deservedly high reputation both for their mechanical and for their optical work, and the prices charged compare favourably with those of other firms.

MESSRS. W. HEFFER & SONS, Ltd., Cambridge, have in the press "Cements and Artificial Stones: A Descriptive Catalogue of the Specimens in the Sedgwick Museum, Cambridge," by the late J. Watson, edited by Dr. R. H. Rastall, in which will be found a brief history of the origin and development of the cement industry, and notes on the manufacture and uses of the various kinds of cement, concrete, and artificial stone which are exhibited in the economic department of the Sedgwick Museum of Geology, at Cambridge. The same publishers also promise "An Introduction to Forecasting Weather," by P. R. Zealley, which aims at presenting in a clear and simple manner the principles on which weather forecasting is based.

## Our Astronomical Column.

EPHEMERIS OF SKJELLERUP'S COMET, 1922 b.—This ephemeris is for Greenwich midnight from the elliptical elements given in NATURE of July 1, p. 20, which are approximately true.

R.A.			N. Decl.	R.A.			N. Decl.
H.	M.	S.		H.	M.	S.	
July 6	15	58.43	37° 53'	July 14	16	37	46
	8	16	10		16	45	45
	10	16	20		18	16	53
	12	16	29		20	16	59
			34 13				27 29

During the interval, June 30-July 20,  $\log r$  increases from 0.0486 to 0.1131;  $\log \Delta$  from 9.5124 to 9.6830. Owing to its short period, it is important to follow it as long as possible in order to facilitate its recovery on its return.

PROF. PLASKETT'S MASSIVE STAR.—Some further particulars about this star (see NATURE, June 17, p. 791) may be of interest. It is in Monoceros, in the middle of the Galaxy, its place for 1900 being R.A. 6<sup>h</sup> 32<sup>m</sup> 0<sup>s</sup>, N. Decl. 6° 13', visual magnitude 6.06. The spectral type in the Henry Draper Catalogue is Bop, but Plaskett prefers Oe5; the orbital velocities of the two components are 206.38, and 246.7 km./sec., the period 14.414 days, the eccentricity 0.0349, the minimum masses of the components 75.6 sun and 63.3 sun. From the non-occurrence of eclipses it is inferred that the orbit is at least 17° from the edgeway position, and the masses 14 per cent. greater than the minimum values. The centre of gravity is receding at 23.94 km./sec. The H and K lines of calcium show no orbital motion, but a steady recession of 15.9 km./sec., which is exactly the amount of the sun's resolved motion, so that the calcium is at rest with respect to the star-system, a result obtained in other spectroscopic binaries. The following estimates are given of the star's size and distance: density 0.01 of sun's, surface brightness 4 magnitudes in excess of sun's, diameters 20 and 18 times sun's, distance between centres 65 sun-diameters, distance from the earth 10,000 light-years, absolute magnitude of brighter component -5.65. It is noted that the recession of the centre of gravity, corrected for solar motion, is 8 km./sec.; with the estimated dimensions and masses, the Einstein spectral shift would account for 2.8 km./sec. of this quantity.

Since this star, the most massive known, lies so near the mean galactic circle, it may be suggested as a suitable zero of galactic longitude; it seems wrong to use the terrestrial equator as the zero point, for it reintroduces precession, which it is the object of galactic co-ordinates to avoid.

ORIGIN OF THE ASTEROIDS.—Dr. K. Hirayama discusses this old problem once more in the June number of *Scientia*. He recalls the early suggestion of an exploded planet, and its abandonment when the wide range of the orbits became known. He then mentions the rival hypotheses, one by one, showing that they too have difficulties. Thus many have suggested that it was the disturbing action of Jupiter that prevented the nebulous ring, assumed to have existed in this region, from forming into a single planet; but he notes that the four great satellites of Jupiter are quite near it, and yet much larger than any of the asteroids. He also notes objections to the theory that the asteroids came from a distance, and had been captured by Jupiter, like

the short-period comets. The orbits of many of them do not approach near enough to Jupiter for this, and their major axes are almost free from perturbation.

Dr. Hirayama himself favours a theory, put forward by Young, which invokes not one, but several explosions. Each "family" of asteroids, of which many have been traced, is explained as the result of an explosion of a single body. In support of this view he refers to the rapid and irregular light-variation of many asteroids, notably Eros. He supposes that they are irregular, angular fragments, their own gravitation being too weak to compel them to take a spherical form; if they were rotating about an axis that was not a principal axis, both the position of the axis in the body and the period of rotation would vary; this agrees with observed facts. It would be possible, by assuming a sufficient number of explosions, to trace the whole system of asteroids to a single primitive planet. As the whole mass of the known asteroids is only some 1/2000 of that of the earth, he thinks it possible that many fragments may have been absorbed by the sun and Jupiter, and in conclusion suggests a similar origin for the ring of Saturn, noting the many resemblances between it and the asteroid system.

NORMAN LOCKYER OBSERVATORY (1921-1922).—In his report for the year 1921, April 1, to 1922, March 31, Dr. W. J. S. Lockyer, the director of the Observatory, directs attention to several advances which will be of interest to observers who have followed the progress of this new institution.

At present the greater part of the work is confined to stellar investigations, and observations were made on 137 of the 149 nights which were sufficiently clear. The McClean telescope, with the 12-inch prismatic camera, has been used for obtaining stellar spectra for classification and parallax determinations. During the year 654 negatives have been secured.

With the 9-inch Kensington prismatic camera 79 negatives have been obtained in the progress of a scheme to photograph the spectra of all stars down to about the fourth magnitude. Special attention is being paid to large-scale spectra of standard giant and dwarf stars of types F to M. These are being examined by Adams' method for the determination of stellar parallax. At the present time 1200 negatives are available, and 370 have been measured, giving preliminary curves showing correlations between absolute magnitude and line-intensity differences. A wedge method of determining the line intensities has been devised, and details of the procedure have been published.

The routine classification of stellar spectra by means of the Kensington nomenclature of generic class names has been discontinued, and the Harvard system, based on numerical measures of line-intensities in the spectra, combined with the separation of stars into groups of increasing (giant) and decreasing (dwarf) temperatures, has been adopted in its place. For laboratory investigations a 10-foot Littrow spectrograph, by Hilger, has been presented to the Observatory by Lady Lockyer.

It is evident that an observatory of this character, with extensive instrumental equipment, is well suited to further the prosecution of investigations beyond those covered by the immediate routine, and it is pleasant to note that during the past year two student observers have been encouraged to spend short periods at the Observatory.

## Research Items.

**THE PEOPLING OF ASIA.**—Dr. Aleš Hrdlička, the distinguished American ethnologist, contributes to the Proceedings of the American Philosophical Society (vol. ix, No. 4) an important paper on the peopling of Asia, which "constitutes one of the greatest problems of anthropology." He concludes that the cradle of humanity was essentially south-western Europe, with, later, the Mediterranean basin, Western Asia, and Africa. It is primarily from Europe and secondarily from these regions that the earth was peopled, and this peopling was comparatively recent. Early man was unable to people the globe owing to his insufficient effectiveness, and until the end of glacial times and his old stone culture he had evidently all he could do to preserve mere existence. Only an advance in culture could enable him to control his environment and secure a steady surplus of births over deaths. The cause of man's peopling of the world was not a mere wish to do so, but the necessity arising from growing numbers and correspondingly decreasing supply of food. It was this which eventually led to agriculture. This spreading over the globe was conditioned by three great laws—movement in the direction of least resistance; movement in the direction of the greatest prospects; movement due to a force from behind, or compulsion.

**COINS OF CROESUS.**—A party of American archaeologists working in Anatolia, among the ruins of Sardis, has discovered thirty gold staters of Croesus, dating from the period between 561 B.C., when Croesus ascended the throne, and 546 B.C., when his capital was taken by Cyrus, king of Persia. They are in excellent condition, although some are a little worn. The only five staters hitherto known to exist are in the British Museum, but only one is in good condition. Dr. Leslie Shear, the archaeologist of Columbia University, who has brought the news of this discovery, states that the coins were found in a small earthen vessel in the ruins of a tomb, where they may have been hidden by a Lydian merchant during the siege of the city by Cyrus. The coins, which are in charge of the discoverers, cannot be brought to America until the right of ownership is decided, but according to the treaty of Sèvres, such articles discovered in territory assigned to Greece should be divided, half to the Constantinople Museum, and half to the finders. The coins of Croesus are made of electrum, or mixed gold and silver, and are of two types, weighing respectively 8.40 grams and 11.20 grams. Those hitherto discovered are oblong in shape, bearing the heads of a lion and a bull.

**AN UPPER PALAEO-LITHIC STATION, AVELINE'S HOLE.**—The report of the Spelaeological Society, University of Bristol, for 1920-21, describes the excavation of Aveline's Hole, a rift cavern in the mountain limestone forming the east wall of Burrington Combe. It was first discovered in 1797, and Rutter, writing in 1829, states that nearly 50 skeletons were found lying with their heads under the north side of the rock and feet extended towards the centre of the cave. The Society commenced work in 1919, and it has continued regularly ever since. Associated with numerous animal remains characteristic of the late Pleistocene were found artifacts of the early Tardenoisian or late Magdalenian periods, agreeing with the determination of the fauna. The human remains belong to the same horizon, since no trace of polished stone or metal weapons, or of any culture other than late Palaeolithic, has been found in the cave, which seems to have been closed with a block

of stone very shortly after the bodies were deposited. The people whose remains were found were contemporaries with the late Magdalenians of southern France, and their culture was Tardenoisian, possibly a transitional stage between the Magdalenian and Aurignacian, an industrial evolution which may have taken place in England.

**THE RED CRAG FLINTS OF FOXHALL.**—In the June issue of *Man* Mr. S. Hazeldene Warren discusses the question of the signs of human handiwork on flints from the Red Crag, Foxhall. He sums up his conclusions as follows: "The Foxhall flints give us another instance of the association of striated surfaces with exclusively mechanical characters in the flakes themselves and in their trimmed edges. And that this association and limitation to the mechanical group of forms does not constitute an unsatisfactory, or doubtful case of not proven, but (from the point of view of a human industry) a definite, complete, and conclusive case of 'proven not'."

**PARASITIC COPEPODS.**—Mr. C. B. Wilson contributes to the Proceedings U.S. Nat. Mus. (vol. 60, art. 5, 1922, 100 pp., 13 plates) his sixteenth paper on the parasitic copepods in the museum collection. The present paper is devoted to the Dichelesthidae, which are parasites on the gills of fishes, but do not burrow into the tissues of their host after the manner of the Lernaeidae, though one genus, *Cetrotodes*, produces irritation of the gill tissue, causing the latter to grow up as a flap or fold entirely surrounding the body of the copepod and holding it securely in place. Other genera provoke irritation by their prehensile claws sufficient to cause the gill tissue to grow up around the claws. The transformations common in the Lernaeidae are not met with in the Dichelesthidae. No material change in the bodily form or structure of these copepods takes place subsequent to their attachment. The author gives a history of the family, a short account of the ecology, external features, and internal organs, systematic descriptions of and keys to the 20 genera and 107 species. The only stage of development known for any of the members of this family is the nauplius, and a description of the known nauplii is given. In the account of the internal structure is included a short note on the closed vascular system of the genus *Lernaphropus*, which consists of two ventral longitudinal trunks below the intestine, and a single dorsal trunk above the intestine, from all three of which branches pass to the appendages, and there is a network of capillaries over the dorsal surface and in the laminate swimming legs. No part of this system is connected with the body cavity (haemocoel). The trunks and capillaries contain a yellowish red fluid which streams backwards and forwards under the influence of the peristaltic movements of the alimentary canal. Neither blood corpuscles "nor any other definite constituents" were found in this fluid.

**INTERSEXUALITY.**—Dr. R. de la Vaulx has given (*Revue générale des Sciences*, March 30, 1922) a short review of recent work on intersexuality—the occurrence of examples intermediate between the normal male and female of the species. Some of these are intersexes, others are more correctly termed gynandromorphs. The former are intermediate in structure between male and female, and are the same on both sides, whereas gynandromorphs consist typically of a mosaic of male and female structures—often one side is male and the other female—and these cases are comparatively rare. The author cites examples of intersexuality from invertebrates—the



butterfly *Lymantria dispar*, the lice *Pediculus humanus* vars. *capitis* and *corporis*, Gammarus and Drosophila, and describes some examples from his own cultures of Daphnia. In Daphnia the intersexes appear not among hybrid examples as in the other cases cited above, but arise during parthenogenetic reproduction, and, on the whole, they seem to have been biased originally towards the male sex and then to have been secondarily feminised. Dr. Vaulx proceeds to discuss whether the intersexual condition is due to the action of two determining factors acting simultaneously or to two forces, e.g. hormones, working successively, and remarks that sex appears to depend on numerous factors or elements, and it has hitherto been found possible to investigate only some of these. He considers that the facts examined lead to two inferences: (a) That sex does not depend on discontinuous factors, or the absence or presence of something as chromosome formulæ suggest, but on complex causes resulting in continuous variation; (b) the unisexual individual possesses potentially the attributes of the other sex, and these may be revealed under certain conditions; it does not seem that one sex can be really homozygous.

ARCTIC ROTIFERA.—In a short account of the Rotifera of the Canadian Arctic Expedition (Report, vol. viii.) Mr. H. K. Harring records 64 species, four of which are new, among which is a pelagic Synchrona—an addition to the extremely small number of rotifers known to exist in the open ocean in waters of normal salinity. The total absence of the genus Brachionus so abundant elsewhere is noteworthy.

CARBONACEOUS MATERIAL IN OILSHALE.—Mr. E. H. Cunningham Craig's recent paper on kukkersite, the oilshale of Esthonia (read before the Institute of Petroleum Technologists on May 9), reopens—among other controversial matters—the question of the origin of the carbonaceous material present in oilshale, a problem upon which the study of this particular deposit may be destined to shed considerable light. The shale is of Ordovician age, and forms part of a Lower Palæozoic sequence remarkable alike for its sedimentary characters and its simplicity of geological structure. Palæontologically the shale has received recent attention from Mr. H. Bekker, who has not only described the Kukkers stage (C<sub>2</sub>), but has given some account of the lithology and mode of deposition of the deposit, together with his views on the origin of the bitumenous matter present. His conclusions differ in many respects from those of Mr. Cunningham Craig, the latter regarding the deposit as a relic oilfield, the former stressing the importance of the part played by diatomaceous algæ and bacteria under a changing environment. Mr. Cunningham Craig regards the shale as being formed by impregnation with inspissated petroleum, derived from the underlying Cambrian beds, a theory presenting many difficulties, some at least as formidable as those possibly occasioned by the phytoplanton theory. Apart from this, the commercial possibilities of the shale are extremely favourable, though one gathers from Mr. Cunningham Craig's remarks that the type of retort used in the past has not been the success anticipated. He estimates the available reserves as 1000 million tons. The yield of oil, at present varying from 40 to 50 gallons per ton, could easily be raised to 70 or even 80 gallons per ton, the oil having a specific gravity not higher than 0.93 and containing very little sulphur. Labour is cheap, and the cost of working and refining the shale should not be great. Altogether Esthonia possesses a deposit valuable alike from scientific and economic standpoints, and the progress of development of this shale will be watched with wide interest.

THE DROUGHT OF 1921.—A communication is given in the Quarterly Journal of the Royal Meteorological Society for April by Mr. C. E. P. Brooks and Mr. J. Glasspoole, of the Meteorological Office, on the drought of 1921, dealt with under the headings of the rainfall of the British Isles and the causes of drought in the British Isles. The year 1921 was in certain areas a year of unprecedentedly small rainfall. The only years since 1850 at all comparable with 1921 were 1854, 1864, 1870, and 1887. In 1854 the deficiency of rain reached its maximum in the south-east, where it was more than 30 per cent., to the east of a line roughly from Bournemouth to Lincoln. In 1864 the maximum deficiency exceeded 30 per cent., over large areas along the east coast and in Devon and Herefordshire. In 1870 the greatest deficiency, exceeding 30 per cent., occurred in the central plain of Scotland and locally in the south and centre of England. In 1887 deficiencies of more than 30 per cent. were widespread in the centre of the British Isles, especially in the south-west of Ireland and in a broad band across England from Southampton to Hull. For England and Wales, 1921 was the driest year since 1850, while for the British Isles as a whole, only one year, 1887, was slightly drier. Indeed, 1921 was probably the driest year since 1788 for England and Wales. A comparison is also made between the general rainfall in 1921 with that of other dry periods of three to nine months' duration, and maps are given showing the several percentages. In the second part of the communication the drought is considered as related to abnormalities in the circulation of the atmosphere. Droughts in the British Isles are closely related to the establishment and the persistence of local anticyclonic conditions, and an attempt is made to find how these abnormalities are related to others in different parts of the world. Maps of the world showing deviations of pressure from normal during the chief periods of drought in the British Isles are given for the occurrences since 1864. Generally speaking, low pressure over the polar regions appears to be an essential feature of drought in the British Isles, and in consequence is considered to be an important factor in forecasting droughts.

FOCAL DEPTHS OF EARTHQUAKES.—The first number of the Geophysical Supplement to the Monthly Notices of the Royal Astronomical Society (for March 1922) consists of a valuable paper by Prof. H. H. Turner on the arrival of earthquake waves at the antipodes and on the measurement of the focal depth of an earthquake. To a distance  $\Delta = 90^\circ$ , the usual tables give good results for the arrival of the primary waves of an earthquake. Beyond this distance there is some uncertainty, but near the antipodes of the epicentre the records again become clear and regular. From  $130^\circ$  to  $180^\circ$  the time of traverse in seconds is given approximately by the expression

$$1217 - (180 - \Delta)^2 \times 0.0235.$$

For a single earthquake, the mean error of the expression is about  $\pm 3.5$  secs., but for the great earthquakes from 1913 to 1916 it is about  $\pm 14$  secs. There is thus a systematic error for each particular earthquake ascribable to a particular depth of focus, which must be greater than 0.021, and may have a value such as 0.04, of the earth's radius. Prof. Turner suggests that the antipodes of the epicentre should be called the hypocentre, a term which has been used for the last thirty years to denote the seismic focus. In Italy its use for this purpose is practically universal. Outside that country, it has been adopted by M. de Montessus de Ballore and Prince Galitzin.

Coral Reefs of the Louisiade Archipelago.<sup>1</sup>

By Prof. W. M. DAVIS, Harvard University.

THE Louisiade archipelago, consisting of four medium-sized and many small islands east of New Guinea, is well represented on British Admiralty chart 2124 on a scale of about 1 : 280,000; chart 1477 shows part of the archipelago in greater detail on a scale of about 1 : 140,000. According to brief accounts by Macgillivray,<sup>2</sup> Thomson,<sup>3</sup> and Maitland,<sup>4</sup> the chief islands are composed of steeply inclined and deeply eroded schists and slates, traversed by quartz veins; they are evidently parts of the mountain range that extends for hundreds of miles along the northern coast of New Guinea, from which they have been separated by strong subsidence after having been eroded to about their present form. The largest island is Tagula, 30 miles in length east-west along the trend of its schists, and 8 or 9 miles in width; it has an embayed shore line and rises in ten summits to heights of from 1330 to 2645 feet. Near by is the Calvados chain of satellite islands, which begins about 7 miles north of the middle of Tagula and extends 70 miles westward; it includes more than a score of members, the largest having a length of 11 miles and a height of 1110 feet. Tagula and its chain of satellites are enclosed by a superb barrier reef, the irregularly oval circuit of which measures 112 miles in east-west diameter by about 30 miles north-south; it is unquestionably one of the finest reefs of its kind in the whole Pacific.

The smaller islands of Rossel to the east and Deboyne to the north-west of Tagula are also surrounded by sea-level reefs, partly as fringes but mostly barriers. Misima, north of Deboyne, measuring 22 by 10 miles and reaching 3500 feet in height, is peculiar in having no sea-level reefs and in descending rapidly into deep water, although it is terraced by unconformable reefs at various altitudes. It has therefore suffered a recent uplift after having previously taken part in the subsidence which characterises the other islands; but its subsidence must have been more rapid than theirs, as it has no widely developed barrier-reef lagoon floor, either near present sea-level or above or below it.

The Tagula barrier reef and its great lagoon merit special attention from the evidence that they give regarding the verity of certain coral-reef theories. The reef is best developed around the south-eastern or windward half of its great oval circuit, where it is interrupted by only four passes in a curved distance of 110 miles, and where the reef flat has a width of 2 or 3 miles. The north-western or leeward half of the barrier is strikingly discontinuous and consists in part of small patches, but more commonly of atoll-like loops and rings, thirty-six in number, from 1 to 5 miles in diameter, enclosing little lagoons from 10 to 17 fathoms in depth. The loops and rings of this half of the circuit are separated by as many passages, from  $\frac{1}{2}$  to 3 miles wide and from 15 to 35 fathoms deep. But the most remarkable features of this part of the barrier are the small or minute but high islands, here to be referred to as outposts, which rise in twenty-two of the reef loops. The largest of them is only 4 miles in diameter; their heights vary from 40 to 530 feet. Some of them appear to consist of schist, judging by

their trends; but according to Maitland some of the others are volcanic and a few are made of limestone. As elements of a barrier reef, these small but high outposts islands are so exceptional as to be almost unique.

The great Tagula lagoon is divided by the Calvados chain of satellite islands into a smaller northern and a larger southern compartment; the northern compartment is of triangular outline, with its base along the dividing chain and its vertex about 10 miles away at the most northern point of the reef; it occupies about one-sixth of the entire reef-enclosed space, which is about 2000 square miles in total area. The southern compartment measures 20 miles across, and extends east-west along the whole 112 miles of the lagoon length; it occupies about four-sixths of the enclosed area; the remaining sixth is taken by Tagula and the satellite islands. The greater part of the lagoon floor in both compartments is a gently undulating plain usually from 25 to 35 fathoms in depth. The depth of the southern compartment increases gradually for a moderate distance from the broad enclosing reef, and more rapidly from the islands of the Calvados chain. The greatest depths, 46 fathoms in the southern or windward compartment and 49 fathoms in the northern or leeward compartment, are in both cases found much nearer the dividing island chain than the outer barrier reef. The exterior slopes of the reef fall off rapidly into deep water; a few soundings show depths of more than 600 fathoms two miles from the reef on the west and north-west.

A correct theory of the Louisiade reefs must take account of the great subsidence that the islands have suffered. It would therefore appear that the present sea-level reefs should be regarded as the successors of a long-lived series of upgrowing reefs which have been formed, essentially according to Darwin's theory, by more or less intermittent growth from earlier shore lines of the subsiding mountainous islands. It is probable that where the island slopes were very steep, the reefs, presumably inclining inwards as they grew up, remained attached to the shore as fringes; conversely, where the island slopes were gentler or where low slopes have been broadly submerged, the reefs now form offshore barriers. During the upgrowth of the reefs, some of their detritus must have been swept seaward, to form the submarine talus that descends into deep water; the rest must have been swept into the lagoons, where, reinforced by local organic detritus and probably in smaller measure by detritus from the islands, it appears to have aggraded the "moats" between the reefs and the islands.

It thus seems that the formation of the great undermass of the Louisiade reefs, and especially of the Tagula reef, may well have been consistent with the conditions and processes of Darwin's theory. It should be added that the evidence for the strong subsidence of the Louisiade islands is, in view of their constitution, much more direct than that furnished for the similar subsidence of most reef-encircled volcanic islands in the central Pacific; and that this well-certified subsidence of the foundations on which the Louisiade reef-masses have been built up gives immensely greater support for Darwin's theory than is afforded by the atolls of the open Pacific, where the occurrence of subsidence is indicated only by indirect evidence. It remains to inquire whether the Louisiade sea-level reefs, which surmount the great undermass, accord with or contradict other coral-reef theories, especially the newly framed Glacial-control theory of sea-level reefs. This theory was proposed

<sup>1</sup> Reprinted from the Proceedings of the National Academy of Sciences<sup>1</sup> Washington, D.C., U.S.A. (vol. 8, No. 1, Jan. 1922).

<sup>2</sup> J. Macgillivray, "Narrative of the Voyage of H.M.S. *Rattlesnake*," London, 1852, 2 vols., See I., 152; II., 72.

<sup>3</sup> B. H. Thomson, "New Guinea: Narrative of an Exploring Expedition to the Louisiade and D'Entrecasteaux Islands," Proc. Roy. Geogr. Soc., 11, 1859 (525-542).

<sup>4</sup> A. G. Maitland, "Geological Observations in British New Guinea," Queensland, Geol. Surv. Pub., 85, 1892. "Salient Geological Features of New Guinea," Journ. W. Austral. N. H. Soc., 2, 1905 (52-59).

more particularly to account for the atolls and barrier reefs of the supposedly quiescent central Pacific than for the barrier reefs of much disturbed regions like the Louisiade archipelago: nevertheless the Tagula reef in particular affords critical evidence against that theory, as will be made clear by the following considerations.

The Glacial-control theory appears to be based on the conviction that it is the smooth lagoon floors rather than their enclosing reefs which are most in need of explanation, and that the bathymetric relation of the lagoon floors to the level of the ocean reached by the enclosing reefs is normally so nearly constant in all the coral seas that their explanation by Darwin's theory in terms of reef upgrowth and lagoon aggradation on subsiding foundations of irregular form is impossible. A long period of nearly perfect stability of the mid-ocean floor is therefore assumed, although instability is admitted for islands in the south-western Pacific; and instead of postulating that lagoon floors represent "moats" that have been heavily aggraded behind the upgrowing reefs during the subsidence of their foundations, a series of ingenious suppositions is invented, of which the chief are: that during Preglacial time many still-standing islands, more or less reef-surrounded, were either worn down to low relief by subaerial erosion or cut down to shallow platforms by marine abrasion; that during the Glacial epochs of the Glacial period the ocean surface was lowered by about 35 fathoms by the withdrawal of water to form continental ice sheets; that the surface waters of the ocean were then so chilled as to kill or greatly to weaken reef-building organisms; that islands were then attacked by the waves, which cut low-level benches around them if they were high, or if they were low completely truncated them in platforms at a depth of 35 to 40 fathoms below normal sea level; that as the waters warmed and rose, reefs grew up on the margins of the benches and platforms, whereupon the lagoons behind them were moderately aggraded; and that the thickness of the aggrading deposits is greater, and consequently the lagoon depth is less in small than in large lagoons, because the detritus supplied from a linear front-foot of a reef has a smaller interior sector to aggrade in a small lagoon than in a large one. In brief, the long-continued stability of reef foundations and the abrasion of sub-lagoon platforms upon them are leading factors of the Glacial-control theory.

It should be noted here that neither the stability of reef foundations nor the abrasion of sub-lagoon platforms is proved by any direct evidence; both of these leading factors are, like the subsidence of atoll foundations in Darwin's theory, assumed because they are thought to be necessary for the explanation of observed facts; and both assumptions are believed to be true because of the apparent success of the explanation that they provide. Hence if it be shown, even in a single instance, that a lagoon floor of typical form and depth has been produced around an island which provides independent evidence contradictory to stability and abrasion and, indeed, requires strong subsidence, the fundamental assumptions of the Glacial-control theory will be seriously invalidated.

The bearing of Tagula reef and lagoon on the Glacial-control theory may now be apprehended. Tagula is, as has already been shown, not in a region of long-continued and nearly perfect stability, but in one of marked instability; and as will next be shown, it has not suffered abrasion by the lowered ocean; yet its lagoon floor is smooth and of a depth accordant with that of other large lagoons in various parts of the Pacific. Hence long-continued stability and extensive low-level abrasion are not essential

factors in the production of this fine example of a barrier-reef lagoon floor. But if these factors are not essential in Tagula, they should not be regarded as essential anywhere else; and their adoption as the leading postulates of the Glacial-control theory is therefore unnecessary; flatness of lagoon floors and their accordant depths may be explained elsewhere as well as in Tagula as the result of long-continued aggradation on subsiding foundations of uneven surface.

The evidence that Tagula has not suffered abrasion by the low Glacial ocean, and hence that the reef-building organisms around Tagula were not seriously weakened by the lowered temperatures of the lowered ocean in the Glacial epochs, is found partly in the absence of chartered cliffs on the shores of the main island where the barrier reef becomes a fringe, partly in the absence of similar cliffs on the exposed sides of the satellite islands at either end of the Calvados chain where it approaches the barrier reef, and partly in the presence of the outpost islands in the barrier-reef loops around the northern lagoon compartment.

As to the first line of evidence based on the absence of cliffs on Tagula: If abrasion by the lowered ocean had operated long enough to cut a platform 10 or 20 miles wide beneath the present floor of the southern compartment, it ought at the same time to have cut spur-end cliffs on the north shore of the main island, where the defending reef is a fringe only half a mile wide; and these cliffs ought still to show the upper part of their faces as plunging cliffs, now that the ocean has resumed its normal level; but the charts show no such cliffs.

The second line of evidence based on the absence of cliffs on the Calvados islands is similarly argued. It may be added that the absence of cliffs at these significant points on the charts of the Louisiade islands does not appear to be due to poor charting; for on the coast of Misima, where Maitland observed the white limestone scarps of elevated reefs, the charts clearly show a shore cliff, and a legend is printed along it: "Cliffs 100 feet high."

As to the third line of evidence: The little outpost islands are so numerous in the Tagula barrier-reef loops around the northern lagoon compartment and around the western part of the southern compartment that it seems unreasonable to believe the waves of the lowered Glacial ocean could have cut their way behind the outposts efficiently enough to abrade a platform 10 miles in width. Not only so, the outpost islands show no sign of having cliffs on their outer sides. One of them, Utian, a mile across and 480 feet high, is reported by Maitland to consist of volcanic rocks; but it is not a young volcanic cone built up in Postglacial time, for the chart shows it to have well-dissected form, with three slender points enclosing two small bays turned toward the outer ocean; yet the points are not cut back in plunging cliffs. Another outpost not far away is said by the same observer to consist of limestone; this island cannot have been made and elevated since an assumed platform was abraded, for the height of the island, 530 feet, is so great that in such case the platform thereabouts ought to be more or less emerged; and it cannot have been made and raised before the platform was cut, for in such case the limestone ought to have been consumed by the waves that cut the platform.

The small outpost islands of the Tagula barrier reef therefore give strong confirmation of the evidence against abrasion derived from the absence of plunging cliffs on the north side of the main islands and on the terminal members of the Calvados chain. But if the northern compartment of the Tagula lagoon,

which alone is as large as many an atoll, is thus shown not to be underlain by an abraded platform, there is no sufficient reason for thinking that the southern compartment, or indeed any other barrier reef or atoll lagoon in the whole Pacific, has any such smoothly prepared foundation. Surely if the flatness of the floor and its normal depth in both compartments of the Tagula lagoon have been brought about in a region of instability, and without the aid of abrasion in furnishing a smooth sub-lagoon platform, there is no sufficient reason for assuming that other flat lagoon floors of ordinary depth can have been prepared only on smooth platforms abraded at a standard depth across still-standing islands. It is possible that the Glacial lowering of the ocean surface by a moderate amount may have contributed, in a manner that I have suggested elsewhere,<sup>5</sup> to the production of many lagoon floors 30 or 40 fathoms in depth; but Glacial changes of ocean level do not seem otherwise to have left recognisable marks of their occurrence in the Louisiade archipelago. Crustal deformation has been dominant; and the great changes of shore lines thus determined appear to have been merely played upon by the inferred oscillations of ocean level during the Glacial period.

This discussion is believed to show that, apart from such changes of ocean level as are inherently probable although they are not well-known either in amount or in effects, the assumptions of the Glacial-control theory are not applicable in the production of Tagula reef and lagoon floor; and hence we may fairly conclude that these assumptions are not essential to the production of similar reefs and lagoon floors elsewhere. This argument, in which the evidence furnished by one outspoken witness for

<sup>5</sup> "Problems associated with the Study of Coral Reef," *Sci. Monthly*, 2, 1916 (595).

Darwin's theory and against the Glacial-control theory is given wide application, would not be valid if other witnesses were equally outspoken elsewhere against Darwin's theory and for the Glacial-control theory; but such is not the case. It must be remembered that the two main postulates of the Glacial-control theory, namely, long-continued stability of reef foundations in the mid-Pacific and the abrasion of sub-lagoon platforms by the lowered Glacial ocean, are not based on direct evidence but are assumed because they are supposed to be necessary for the explanation of smooth lagoon floors of standard depths. Not a single example of an abraded platform has been discovered under recently uplifted reefs; and a large number of mid-Pacific islands which have a decipherable recent history are found now to have been long stable but to have suffered various changes of level. In other words, where other outspoken witnesses are found, their testimony is, like that of Tagula, for Darwin's theory of up-growing reefs on subsiding foundations of whatever shape. A large number of examples of this kind could be adduced if space permitted.

But although the inhibition of reef growth and the resulting abrasion of low-level platforms by the Glacial ocean thus appear to be excluded from the greater part of the coral seas, it is highly probable that reef-building organisms may have been weakened or killed and that abrasion of platforms may have taken place around islands near the margin of the coral seas; and at least some of those islands ought now to show plunging cliffs in evidence of their possession of submerged platforms; but even there the islands need not have been stable. This aspect of the coral-reef problem is examined in an essay submitted to the Geological Society of America for publication in its Bulletin.

### Root Respiration.<sup>1</sup>

ALTHOUGH so much work has been done on the question of root respiration, it is only within the last few years that the importance of the air content of the soil in this connexion has been clearly demonstrated. With the growth of ecological work has come the indication that this air content is a primary factor in many habitats and a controlling one in wet soil and water, but even yet this is not generally recognised.

Mr. F. E. Clements has endeavoured to clear the ground for further research in this direction by summarising the available information in all its aspects. From the time of Mayou (1668) the necessity of oxygen for root activity has been recognised, and numerous investigations have since added to the bulk of evidence with studies of germination, anaerobic respiration, and the respiratory behaviour of underground parts other than roots. The excretion of carbon-dioxide by the roots was first noted by Hales (1727), but the possible excretion of other substances is still a matter of controversy at the present day. Molisch first showed that roots exhibit the phenomenon of aerotropism or response to different concentrations of various gases. This is of great significance in plants inhabiting bogs and swampy land, as in order to obtain the oxygen necessary for respiration they develop aerotropic roots which run horizontally above the oxygen-free swamp soil, as in *Alnus*, or rise vertically in the air, as in *Avicennia*.

The composition of the soil air varies considerably with the nature of the soil, time of year, and seasonal

<sup>1</sup> "Aeration and Air Content: the Role of Oxygen in Root Activity," by Frederic E. Clements. Pp. 183. (Publication 315.) (Washington: Carnegie Institution, 1921.) 2 dollars.

changes, and is also affected by cultivation and plant growth, which increase the carbon-dioxide and diminish the oxygen in proportion. It has been suggested by Bristol that the presence of algae may also affect the soil gases.

Anaerobic respiration is of much significance in connexion with reduced oxygen supply. The general effect of the reduction or absence of oxygen on respiration is to reduce its intensity, but respiration under anaerobic conditions differs with the species. Carbon-dioxide and alcohol are the regular products of such respiration, which is consequently regarded by most investigators as essentially identical with alcoholic fermentation when carbohydrates are present. Under certain conditions acetic, formic, and lactic acids are excreted from the roots and other parts of flowering plants. After considering the relation of photosynthesis, transpiration, and germination to oxygen supply, Mr. Clements enunciates the general rule that growth is decreased or prevented by the absence of oxygen. The movement of protoplasm in plant cells is stopped, and practically all tropistic responses are suppressed.

Field studies of aeration, approached from the agricultural, pathological, and ecological standpoints, corroborate the results of physiological investigation as to the basic importance of oxygen for root activity and the injury wrought by the accumulation of carbon-dioxide. The practical importance of this appears most strikingly in irrigated regions where the common practice involves the use of too much water, with consequent economic loss, due to the production of an oxygen deficit in the soil.

The problem of soil aeration and the way in which it works injury to plants is much under discussion, but it appears certain that in some soils the lack of oxygen and the accumulation of carbon-dioxide are primary factors, while the organic acids and salts arising from anaerobiosis may play some part. In other cases acidity brings salts of aluminium, iron,

or manganese into solution, which then exert a toxic effect.

Finally, after putting forward the present position of affairs with regard to toxic exudates and soil toxins, the author concludes his valuable survey with a comprehensive bibliography which contains more than seven hundred references. W. E. B.

### Radio Direction Finding in Flying Machines.

THERE is little doubt that radio direction finders and other radio devices will soon be in regular use to enable aeroplanes to land at night, during fogs or at other times of poor visibility. The usual method is to transmit signals from an antenna in the landing field to the direction-finder on the aeroplane. This, however, gives merely the direction of the landing-field and provides no indication to the navigator of his distance from his destination.

Some years ago the Bureau of Standards in America experimented with induction signalling. A large horizontal single turn coil, 600 by 800 feet, was erected at the landing-stage. It was tuned to resonance at a frequency of 500 so that it produced a very powerful alternating magnetic field over a wide area in the neighbourhood. It was found that induction effects could be detected at considerable distances when the aeroplane was at a low altitude, but at the height of a mile they could be detected only throughout a small area directly over the coil. The tests showed that what was wanted was a hollow conical beam of radiation, the vertex of the beam being on the landing ground. At low altitudes it was very important that the signal should be audible over only a very limited range.

This has been effected by means of two equal coaxial coils with their planes horizontal and at different altitudes. The current, which has a radio-frequency of 300,000, flows in opposite directions in the two coils. Under these conditions the signals are received at the aeroplane only when the machine is in the immediate neighbourhood and approaching or receding from the station.

Gregory Breit, a physicist of the Bureau of Standards, has worked out mathematically the nature of the field from the two horizontal coils. It is proved that the maximum intensity of the signals occurs when the angle which the line joining the aeroplane with the landing-stage makes with the vertical is approximately  $30^\circ$ . The region of space within which the signal can be detected is nearly the space between two inverted coaxial cones with their axes vertical and their common apex at the transmitting station. The signals are inaudible directly overhead and rapidly die away when the aeroplane passes through the conical surface where the sound is a maximum. The lower the aeroplane also the louder the noise. The theoretical results have proved of great value in designing stations for emitting landing signals, and should be of considerable practical importance.

### Industrial Research in India.

ONE of the bye-products of the new constitution legalised by the Government of India Act of 1919 was the transfer of certain "heads of business," previously administered by the bureaucratic regime, to the control of popularly elected Ministers in each province. The subjects so transferred included agriculture, forests, and the development of industries, with, therefore, the scientific and technical services attached to these departments. Realising that "decentralisation of authority and responsibility must necessarily tend to give rise to local variations in policy, apart altogether from those variations that follow local diversity in natural resources," Sir Thomas Holland, when designing the new Department of Industries and Labour in 1920, elaborated a system which would facilitate concerted action among the provinces while leaving them free to develop in any way that seemed to their respective legislatures best suited to their special needs. The new Ministers were, in the first instance, provided with a monthly circular summarising the information, often of a semi-confidential nature, collected by the Intelligence Branch of the Munitions Board. Out of these circulars grew the agenda of half-yearly conferences, followed by a quarterly Journal and a series of Bulletins suitable for publication.

During 1921 four parts of the first volume of the Journal, amounting to 568 pages, well illustrated and fully indexed, were issued, and we have now received the first part of the new volume for 1922, together with twenty-three Bulletins on special subjects. The first part of the Journal published in 1921 was noticed last year in NATURE of April 7 (vol. 107, p. 179), and it is satisfactory to observe that the quality of the papers and the fundamental object of the publication have both been faithfully maintained.

Some of the articles, like those by Dr. E. R. Watson and Mr. Mukerji on the alkaline "bad lands" of the United Provinces, by Mr. B. M. Das on the tan-stuffs of the mangrove swamps on the Gangetic delta, by Mr. Appleyard on the manufacture of acetone and butyl alcohol, and by Messrs. Gadre and Mukerji on rose otto, include the results of original research; but generally the articles and notes have an industrial rather than a scientific bias, avoiding the ground covered by those scientific and technical departments that have established journals of their own. Problems of factory welfare, which are beginning to assume embarrassing importance in India, occupy a conspicuous place among papers describing local ventures in glass manufacture, paper-making, tanning, pottery, oil-extraction, perfume distillation, wire-drawing, textile manufacture, and mineral enterprises.

The progress reports provided quarterly by the provincial Directors of Industries show the efforts being made to carry out the recommendations of the Industrial Commission which delivered its report towards the end of 1918. The reports generally give some justification for the claim made by Lord Chelmsford in his article in the *United Empire* for December last (vol. xii. p. 778) that "never has effect been given more expeditiously" to a Commission's report. Differences of provincial outlook, however, still retard the adoption of the excellent scheme of chemical research drawn up by Prof. Thorpe's Committee in 1920; and without some such organisation to this end, by co-operation among the provinces, the industries of India must always retain their primitive "configuration" and remain distinctly behind, for example, those of a country like Japan.

### Rainfall in Southern Italy and Tripoli.

PROF. FILIPPO EREDIA, of the Italian Meteorological Service, has recently contributed some further climatological studies to the many which he has already published. One of these (*Nuovi Annali del Ministero per l'Agricoltura*) deals with the seasonal conditions of rainfall in the province of Apulia and the relation of the quantity of precipitation to the number of days of incidence. The matter is important in connexion with the somewhat precarious water supply in that southern Italian province, which during the summer months is affected by the Saharan regimen of drought.

In another publication, on the rainfall of Tripoli (*"L' Agricoltura Coloniale," Anno xv., No. 8, 1921*), Prof. Eredia shows that there is no foundation for the supposition that the rainfall of the region is steadily diminishing because the country shows signs of progressive desiccation. One might remark that progressive desiccation is considered to be the fact in many parts of Africa other than Tripoli, and that it has been explained by Schwarz and others as due, not to diminishing rainfall, but to a continental configuration which is slowly inducing baneful hydrological changes.

Two other papers on the climates of Gharian and Cussabat on the interior plateau of Tripoli (*Bollettino di Informazioni, Nos. 3-4, 7-8, 1921*) give an interesting glimpse of general climatic conditions based on a few years' records for meteorological observations since the Italian occupation. The mean annual temperature at Gharian, high up on the plateau and more than 2000 feet above sea-level, is about 65° F., ranging between 83° in July and 48° in January, and the mean daily range varies from 30° F. at midsummer to less than half that value at mid-winter. The absolute extremes of temperature recorded at this station were 121.1° F. in June and 32.1° F. in December, whilst extreme fluctuations of relative humidity characterise this dry region. The general rainfall of Tripoli is less than 20 inches a year, chiefly confined to winter. In this region we have another instance of the fact that occasional snowfalls at sea-level make a much closer approach to the tropics than is commonly supposed.

### University and Educational Intelligence.

BANGOR.—Prof. D. Thoday of the University of Cape Town has been appointed to the chair of botany, in succession to Prof. R. W. Phillips, who retires after thirty-eight years' service.

BIRMINGHAM.—At the Degree Congregation held on July 1, in the great hall of the University at Edgbaston, the number of degrees conferred was the largest hitherto recorded for the University. Many of the new graduates are ex-service men, and the Principal (Mr. C. Grant Robertson) paid a tribute to the work of these men and their valuable help in creating afresh traditions of the University after the war: "They have given us invaluable service in that necessary work. They brought to the University a breadth and a variety of experience, a maturity of judgment, and an energy and enthusiasm which those who know the University from the inside recognise has been invaluable, and which will leave a permanent imprint on our University life and a permanent addition to our University traditions." The institution by the Government of grants to ex-service men was a unique educational experiment and, judging by the experience of Birmingham University, it had proved an unqualified success.

The following degrees were conferred: *Doctor of*

*Science*: Mr. R. H. Whitehouse; *Doctor of Medicine*: Mr. O. J. Kaufmann, Mr. J. Robertson, and Mr. J. W. Russell; *Philosophiæ Doctor*: Mr. F. Adcock, Mr. C. B. Childs, Mr. V. A. Collins, Mr. E. A. F. Reeve, Mr. J. D. M. Smith, Mr. R. E. Stradling, Mr. E. H. Wells; *Master of Surgery*: Mr. L. P. Gamgee. For the degree of Master of Science, 45 candidates were presented; for the degree of B.Sc. with Honours, there were 74 candidates, and for the ordinary B.Sc. degree, 157.

The Vice-Chancellor, Sir Gilbert Barling, announced that a war memorial was to be erected on the east wall of the entrance hall, in the form of three marble panels bearing the names of the members of the University of all ranks who fell in the war. It is expected that the memorial will be unveiled in October next.

Mr. C. G. Payton has been appointed demonstrator in anatomy.

The Ingleby Lecturer for 1924 will be Mr. A. W. Nuthall.

CAMBRIDGE.—In connexion with the meeting of the Royal Agricultural Society (the "Royal Show"), honorary degrees are being conferred on H.R.H. The Duke of York, the Honourable W. H. Taft, Mr. C. R. W. Adeane, Sir G. Greenall, Sir Daniel Hall, Mr. E. S. Beaven, Mr. A. E. Humphries, Mr. E. Mathews, and Mr. G. P. Hawkins. Mr. L. C. G. Clarke, Trinity College, has been appointed curator of the Museum of Archaeology and of Ethnology.

LONDON.—Prof. H. S. Birkett (Dean of the Faculty of Medicine, McGill University) will deliver the Semon Lecture at the Royal Society of Medicine, 1 Wimpole Street, W.1, on Wednesday, July 12, at 5 o'clock. The subject will be "The development of Trans-Atlantic Rhino-laryngology." Admission will be free and no tickets will be required.

OXFORD.—At the Encaenia, held on June 28, the honorary degree of D.Sc. was conferred on Prof. J. Perrin of Paris and Prof. F. Gowland Hopkins of Cambridge. In introducing Prof. Perrin, the Public Orator (Dr. Godley) referred particularly to his experimental researches in the character and constitution of the atom, and to his determination of the velocity of the component electrons. His scientific investigations had been used in the service of his country, and had contributed largely to its victory in the war. Of the work in biochemistry of Prof. Gowland Hopkins, the Orator found it difficult to speak "in hac patriæ sermonis egestate." He was able, however, to pay tribute in general terms to Prof. Hopkins's abstruse researches into the nutrition and metabolism of living bodies. His discovery of the importance of vitamins was not only of high scientific value, but had also a practical bearing of the greatest interest in the study of disease. Prof. Perrin was greeted by the Vice-Chancellor (Dr. L. R. Farnell, Rector of Exeter College) as "Vir doctissime; maxime physicae scientiæ auctor"; and Prof. Hopkins as "Vir eruditissime; chemiæ explorator insignis; Universitatis Cantabrigiensi decus."

SHEFFIELD.—Honorary degrees have been conferred on Sir Charles Parsons for his work on the turbine engine, and on Mr. T. W. Hall for researches in palæography and archaeology.

DR. R. H. CHITTENDEN, the well-known authority on dietetics, is retiring from the post of director of the Sheffield Scientific School, Yale University, which he has held since 1898. He is to be succeeded by Dr. C. H. Warren, now professor of mineralogy at the Massachusetts Institute of Technology and a former assistant at the Sheffield Scientific School, of which he is himself a graduate.

## Calendar of Industrial Pioneers.

**July 1, 1860.** Charles Goodyear died.—The father of the American rubber industry, Goodyear was born at New Haven, Connecticut, on December 12, 1800, his father, Amasa Goodyear, being known as an inventor of agricultural implements and a manufacturer of hardware. The failure of his father's business about 1830 led Goodyear to study the problem of "curing" rubber, which at that time became soft and sticky in summer and brittle in winter. Always in debt, sometimes in prison, and often regarded as a crank, Goodyear persevered until, in 1839, he accidentally discovered that by partly melting rubber and sulphur the rubber could be given varying degrees of hardness and elasticity. His first patent was taken out in 1844, and though he reaped no fortune he continued to improve the manufacture and extend the use of rubber until his death.

**July 2, 1798.** John Fitch died.—One of the pioneers of steam navigation, Fitch was the son of a farmer of Windsor, Connecticut, and was born on January 21, 1743. After a few sea voyages he engaged in clockmaking and brassfounding, and as a gunsmith to the American troops during the War of Independence made a considerable fortune. His project of driving boats by steam was launched in 1785, and the following year he formed a company and secured exclusive rights in New Jersey and other States. A boat built by him and placed upon the Delaware in 1790 was the first steam vessel to convey passengers for hire. The undertaking, however, proved financially unsuccessful, and three years later Fitch met with no more success in France. Reaping nothing but disappointment and poverty, his mind gave way, and he died by his own hand at Bardstown, Kentucky.

**July 5, 1826.** Joseph Louis Proust died.—Trained as a chemist by his father, Proust made one of the earliest balloon ascents, was for some years employed by the King of Spain, and discovered a process of making grape sugar. He was also known for the enunciation of the law of constant proportion and for his controversies with Berthollet.

**July 5, 1883.** Robert Spence died.—Beginning life as a grocer, Spence afterwards found employment in the Dundee Gas-works and became the proprietor of chemical works in London, Manchester, and elsewhere. In 1845 he discovered the process of making alum from the refuse shale of collieries and the waste ammoniacal liquor of gas-works, and became the chief alum manufacturer in the world. He also took out many patents in connexion with industrial chemistry and metallurgy.

**July 7, 1850.** Timothy Hackworth died.—Born at Wylam, near Newcastle, in 1786, Hackworth became a foreman smith and assisted in some of the pioneering work on the locomotive. Appointed in 1825 resident engineer and manager of the Stockton and Darlington Railway, he built the *Royal George*, which definitely asserted the superiority of steam over horse traction, and in 1829 produced the *Sans Pareil*, a worthy competitor with Stephenson's *Rocket*, at Rainhill.

**July 7, 1896.** Sir John Pender died.—A successful merchant in textile fabrics in Manchester and Glasgow, Pender was an enthusiastic supporter of submarine telegraphy, and was one of the 345 subscribers who each risked a thousand pounds in the Atlantic Cable of 1857. He personally guaranteed 250,000*l.* to the Telegraph Construction and Maintenance Company in 1865, and at his death was the head of various concerns owning 73,640 nautical miles of submarine cable and having a capital of fifteen millions.

**July 10, 1867.** Thomas Richardson died.—Trained as a chemist under Thomas Thomson, Liebig, and Pelouze, Richardson became a chemical manufacturer at Newcastle, introduced improvements in the production of lead, and began the manufacture of superphosphates. He lectured on chemistry in Durham University, published information about the industries of the north, and with Ronalds translated Knapp's "Technological Chemistry."

**July 10, 1874.** John Grantham died.—The author of a standard work on iron shipbuilding, Grantham designed many sailing-ships and steamships, patented a screw-propeller, and devised a method of sheathing iron ships with copper. He was also joint engineer with his brother to the northern railway of Buenos Aires and planned the first tramway in Copenhagen. He was one of the founders of the Institution of Naval Architects.

**July 12, 1892.** Cyrus West Field died.—Born in Stockbridge, Massachusetts, November 30, 1819, Field built up a large paper-manufacturing business, and then in 1854 turned his attention to submarine telegraphy, ultimately becoming the chief promoter of the Atlantic Telegraph. It has been said, "Let who will claim the merit of having said the Atlantic cable was possible, to Mr. Field is due the inalienable credit of having made it possible, and of giving to an abortive conception all the attributes of healthy existence." His share in the great enterprise was recognised by the award to him by Congress of a gold medal, and he received the thanks of the American nation.

**July 12, 1910.** Charles Stewart Rolls died.—A pioneer of the motor-car in England, an expert aeronaut, and the first English victim of aviation, Rolls was the son of Baron Llangattock and was born August 28, 1877. Educated at Eton and Trinity College, Cambridge, he studied practical engineering, and in 1895 purchased his first motor car. Nine years later he founded the well-known firm of Rolls-Royce, Ltd. To study Wilbur Wright's experiments he visited France in 1908, acquired a Wright aeroplane, and became an expert flyer. In June 1910 he crossed and recrossed the Channel without stopping. His death was due to an accident to the machine he was flying at Bournemouth.

**July 14, 1806.** Emiland Marie Gauthey died.—A student at the École des Ponts et Chaussées, under the celebrated Perronet, Gauthey rose to eminence in the French service, and was especially known for the construction of the Canal du Centre in Burgundy. His "*Traité complet sur la construction des ponts et des canaux navigables*" was published in 1809 by his nephew Navier.

**July 14, 1808.** John Wilkinson died.—The father of the iron trade in Staffordshire, Wilkinson was born in 1728, and learned the art of smelting from his father. In 1748 he built a blast furnace at Bilston, Staffordshire, using coke for fuel, and afterwards had works at Bersham and Broseley. He introduced the boring of cannon, in 1787 he constructed an iron barge, and he also patented a method of making lead pipes.

**July 14, 1887.** Alfred Krupp died.—The son of Friedrich Krupp (1787-1826), who opened a small iron forge at Essen in 1810, Alfred Krupp was born April 26, 1812, and at an early age succeeded to the management of the business which, in his hands, became of world-wide importance. He made the first steel gun, established the first Bessemer works in Germany, and manufactured large quantities of ordnance and railway material. The works at Essen cover an area of about five square miles, while the firm, in its various establishments, employs some 80,000 men.

E. C. S.

## Societies and Academies.

LONDON.

**Royal Society, June 22.**—Sir Charles Sherrington, president, in the chair.—G. I. Taylor: The motion of a sphere in a rotating liquid. There are an infinite number of solutions to the equations of motion of a rotating fluid, when a sphere is moved uniformly along the axis of rotation, which satisfy the boundary conditions and the conditions at infinity. They are characterised by spherical rotational waves which accompany the sphere. The radius of the sphere may be reduced to zero without reducing the disturbance in the fluid to zero. The equations then represent a motion which is finite and continuous at the centre, and consists of a central core of fluid which rotates more slowly than the surrounding fluid and travels along the axis with a constant speed.—T. R. Merton and D. N. Harrison: On errors arising in the measurement of unsymmetrical spectrum lines. The instrumental displacements occurring while spectra are being photographed can be rendered innocuous, for wave-length determinations, only when the spectrum lines are symmetrical. With uniform displacement of a line during exposure, the maximum on the photographic plate occurs where the intensity distribution curves at the beginning and end of the exposure intersect. When the ratio of the widths on either side of the maximum of the curve remains constant for all values of the intensity, the displacement of the maximum is simply related to the "index of asymmetry" of the line.—E. F. Armstrong and T. P. Hilditch: A study of catalytic actions at solid surfaces. Pt. VIII. The action of sodium carbonate in promoting the hydrogenation of phenol. Small amounts of mild alkali, especially anhydrous sodium carbonate, stimulate the hydrogenation of liquid phenol in presence of nickel. The amount of sodium carbonate has a specific influence, the optimum being about 25 per cent. of the weight of metallic nickel present. The hydrogen-adsorption time curves for phenol in presence of nickel and in absence of sodium carbonate are of logarithmic type; with the optimum concentration of carbonate they are approximately linear. The sodium carbonate suppresses a retarding or poisoning influence, leaving the nickel free to exercise its normal function. The toxic agent appears to be some stable association between the nickel and phenol, or a product from the latter, possibly nickel phenate. Pt. IX. The action of copper in promoting the activity of nickel catalyst. Copper-nickel catalysts prepared at 180° C. are not so active as the plain nickel catalyst, distributed to give the maximum surface area, reduced at a higher temperature. For maximum activity, the proportions of the mixed carbonates must be such that nickel  $\alpha$ -cupri-carbonate is present in the precipitate. The preparations yielding active catalysts respond to Pickering's tests for complex cupri-carbonates. The production of a little reduced nickel at this low temperature is conditioned, perhaps, by the heat liberated in the reduction of the copper.—E. A. Milne: Radiative equilibrium: the relation between the spectral energy curve of a star and the law of darkening of the disc towards the limb, with special reference to the effects of scattering and the solar spectrum. For stars in radiative equilibrium the darkening of the disc towards the limb in wave-length  $\lambda$  depends only on the product  $\lambda T$ ,  $T$  being the effective temperature. The ratio of the intensity

at the limb to that at the centre increases as  $\lambda T$  increases, but never exceeds 0.8; it approaches zero for small values of  $\lambda T$ . For stars not in radiative equilibrium the coefficient of darkening in the integrated radiation must lie between  $\frac{2}{3}$  and  $\frac{1}{2}$ , and the temperature distribution near the surface can be deduced. Selective absorption in the continuous spectrum alters the law of darkening. A scattering atmosphere round a star should make the coefficients of darkening in all wave-lengths tend to the same value, about  $\frac{2}{3}$ . The observed darkening of the continuous solar spectrum differs very little from the theoretical darkening for radiative equilibrium; it is not possible to correlate the spectrum with the darkening, either on the hypothesis of selective absorption or on that of a scattering atmosphere. Probably there is no scattering atmosphere of appreciable optical thickness round the sun, and the bulk of the emergent radiation is not scattered light.—C. N. Hinshelwood: On the structure and chemical activity of copper films and the colour changes accompanying their oxidation. The gradual activation of a copper surface in a series of oxidations and reductions has been studied at pressures of a few millimetres. A limiting state appears to be reached in which the copper film has an open structure consisting of granules of radius a small fraction of  $1\mu$ . During oxidation, brilliant diffraction colours are observed, depending upon the composition of the separate granules. The mechanism by which the film becomes granular is discussed.—R. C. Ray: Heat of crystallisation of quartz. The difference between the heats of solution of quartz and silica glass in aqueous hydrofluoric acid, and the specific heats of aqueous hydrofluoric acid represents the heat of crystallisation of quartz at the ordinary temperature, and is 6.95 kilogram calories. Grinding converts the crystalline material partly into the vitreous state. Near the melting-point the heat of crystallisation is probably nearly equal to that at air temperature.—C. G. Schoneboom: Diffusion and intertraction. With fluid-mixing, in addition to diffusion, another specific operating factor called "intertraction" has been found experimentally. Clerk Maxwell, in discussing interfacial tension, concluded that an interpenetrating movement of this kind was *a priori* to be expected. The phenomenon has been described by Sir Alnroth Wright in the special case of the admixture of serum and salt solutions, but it can be obtained with practically any substance in any solvent.

**Geological Society, June 14.**—Dr. G. T. Prior, vice-president, in the chair.—P. G. H. Boswell: The petrography of the Cretaceous and Tertiary outliers of the west of England. The outliers of Upper Greensand on the Haldon Hills, the Eocene (?) of Marazion, Buckland Brewer, and the Haldon Hills, and the Oligocene of Bovey Tracey and Petrockstow are discussed. Andalusite, topaz, and tourmaline are the typical minerals. Minerals foreign to the West Country, such as kyanite and staurolite, are also abundant in the Cretaceous and Pliocene. The mineralogical constitution yields evidence of a progressive restriction of drainage-area, commencing with the marine and glauconitic Greensand and continuing through the fluviatile (?) Eocene to the lacustrine Bovey deposits, and of a reversion to marine conditions with a polygenetic mineral assemblage in the Pliocene.—W. N. Benson and S. Smith: On some rugose corals from the Burindi Series (Lower Carboniferous) of New South Wales. The corals were obtained from the western foothills of the New England Plateau, in the north-eastern portion of the



country. The region consists mainly of Upper Paleozoic rocks, Devonian to Permian. The Burindi Series is made up of olive-green mudstones and tuffs, with occasional lenticular masses of oolitic and crinoidal limestone. From these intercalations the corals, which are related to *Cyathophyllum* and *Lithostrotion*, were obtained. Both forms have abnormally large columellae. The species of *Lithostrotion* have small peculiarities of structure, which distinguish them as a group from British species.

## EDINBURGH.

Royal Society, June 5.—Prof. F. O. Bower, president, in the chair.—A. N. Whitehead: The relatedness of Nature. Hume disposed of the theory of the relatedness of Nature as it existed in the current philosophy of his time. We can discern in Nature a ground of uniformity of which the more far-reaching example is the uniformity of space-time, and the more limited example is what is usually known under the title of "The Uniformity of Nature." Our arguments must be based upon considerations of the utmost generality, untouched by the peculiar features of any particular natural science. Every entity is an abstraction from the concrete, which in its fullest sense means totality. The important point of that doctrine is that any factor of Nature, by virtue of its status as a limitation within totality, naturally refers to factors of totality other than itself. Equality of limitude is the significance of factors. The uniform significance of events becomes the uniform spatio-temporal structure. In that respect it is necessary to dissent from Einstein, who assumes for that structure casual heterogeneity arising from contingent relations. The structure is uniform because of the necessity for knowledge that there should be a system of uniform relatedness, in terms of which the contingent relations of natural factors can be expressed. Otherwise we can know nothing until we know everything. It is evident that a scientific object such as an electron must qualify future events, for otherwise the future contingency is unaffected by it. In that, a scientific object differs decisively from a sense-object. A sense-object qualifies events in the present. Thus, the seemingly contingent play of the senses is controlled by the conditions brought about by its dependence upon the qualification of events introduced by the scientific object.

## SHEFFIELD.

Society of Glass Technology, June 21.—Prof. W. E. S. Turner in the chair.—Y. Amenomiya: The devitrification caused upon the surface of sheet glass by heat. Heat causes devitrification, or crystallisation of window glass. This alteration takes place between 700° and 800° C.—K. Kamita: The influence of alumina in preventing the devitrification of sheet glass during the drawing process. As the amount of alumina in the glass increased in the samples used, so the temperature at which devitrification occurred was raised; 5 per cent. of alumina caused a rise of approximately 100° C. in the temperature at which devitrification commences.—L. E. Norton: The apparent swelling of sand on the addition of water. With three typical sands the addition of water caused difficulty in packing equivalent to swelling which might be 12-15 per cent. of the total dry sand. The maximum effect occurred when 5-6 per cent. of water was mixed with the sand.—W. E. S. Turner: The mixing of batch. Taking three works samples from batch mixed by hand, the maximum variations were

44-77 per cent. sand and 4-8-8-3 per cent. lime, while a similar batch mixed by different machines showed variations of 69-73 per cent. sand and 4-2-6-6 per cent. lime. Machine mixing, by giving a much more regular batch, assisted the melting, and materially reduced the time necessary for the production of good glass.

## PARIS.

Academy of Sciences, June 12.—M. Emile Bertin in the chair.—Henry le Chatelier: The geometric representation of saline equilibria. Remarks on a question of priority raised by Prof. Jaenecke.—Charles Depéret: An attempt at the general chronological co-ordination of quaternary time.—Maurice Leblanc: The use of air as a cooling agent. A theoretical and practical comparison of the use of liquid ammonia and compressed air as cooling agents, with a study of the best conditions for using the latter.—A. Rateau: General theory of the turbo-compressor for aviation motors. The compressor is worked by the exhaust gases from the engine and delivers the air to the cylinder at about double the atmospheric pressure. It is especially designed for use at high altitudes.—M. Riquier: Singular integral figures of passive systems of the first order involving only a single unknown function.—Jules Andrade: Three classes of non-maintained isochronal vibrations and three types of timepieces. New instruments for the experimental study of viscosities.—G. Friedel and L. Royer: Liquids with Grandjean's equidistant planes.—Torsten Carleman: Asymptotic series.—G. Valiron: Hermite's method of approximation.—Georges Rémondos: The general problem of the thrust of earth.—M. Sudria: The elastic deformation of an isotropic body.—E. Merlin: The calculation of heliographic co-ordinates.—M. Dufour: The refraction of a luminous pencil in the general case.—A. Andant: The variations of critical opalescence with the filling of the tubes and the nature of the liquids studied. The effects of the variation of critical opalescence with the temperature and with the wavelength of the incident light have been described in an earlier paper. The ratio of liquid to vapour in the tube (D) also affects the phenomenon, and the temperature of reappearance of the meniscus is now shown to be a parabolic function of D. A study of the acetates of methyl, ethyl, butyl, and isobutyl shows that the opalescence increases in intensity and extent, passing from the first to the fourth of these acetates.—A. Dauvillier: The exact measurement of the energy levels of the barium atom and the appearance of the L ionisation spectrum.—M. de Broglie and A. Dauvillier: A new absorption phenomenon observed in the field of the X-rays.—A. Damiens: The crystallisation of amorphous tellurium. According to Berthelot and Fabre, the crystallisation of tellurium is an endothermic phenomenon, thus forming an exception to the general rule. A repetition of the experiments of Berthelot and Fabre has shown that the reaction used by them (bromination of tellurium) is not complete in the case of crystallised tellurium, and by substituting bromine in hydrochloric acid for bromine and water it is proved that the change from amorphous to crystallised tellurium is accompanied by an evolution of heat. Tellurium thus falls into line with other amorphous substances.—R. Locquin and Sung Wouseng: The preparation of the dialkylvinyl-carbinols. A general method for preparing the unsaturated alcohols of the type  $RR'-C(OH)-C=CH$  has been given in an earlier communication. By a suitable catalyst (reduced nickel) these can be reduced by hydrogen to the corresponding tertiary ethylene alcohols

RR'-C(OH)-CH=CH<sub>2</sub>; the preparation and properties of three of these are described.—E. E. Blaise and Mlle. Montagne: The action of thionyl chloride on the  $\alpha$ -acid alcohols. With lactic and  $\alpha$ -oxyisobutyric acids, thionyl chloride forms anhydrocompounds of a new type.—M.M. Pastureau and Henri Bernard: The chlorhydrin of mesityl oxide and its transformation into the chlorhydrin of tetramethyl glycerol.—Edmond Gain: The comparative resistance to heat of the growing points of the embryo of the sunflower. If the seeds have been submitted before germination to temperatures just below those capable of destroying life (110° to 155° C.) the various points capable of growth are shown to be unequally sensitive, that of the root being most easily destroyed.—Maurice Lenoir: Somatic kinesis in the aerial stem of *Equisetum arvense*. From the facts described it would appear that the fundamental substance of the chromosome is the nucleolin; the chromatin is derived from it.—Mlle. Marguerite Larbaud: The anatomy of flowers of the same species at different altitudes. A detailed comparison of plants of *Silene inflata* grown at about sea-level and at 2000 metres altitude.—Gabriel Bidou: An artificial musculometer.—Clément Vaney and Jean Pelosse: Origin of the natural coloration of the silk of *Bombyx mori*. The colouring matter from the silk and that derived from the leaves of the mulberry tree give identical absorption spectra in alcoholic solution. This confirms the view of Conte and Levrat that the silk cocoons derive their colour from the pigments of the leaf serving as food for the silkworms.—M. Aron: The development of the primary sexual characters in *Triton cristatus*. Hypothesis on its determinism.—P. Bouin: Dipyrenid of the sperm in certain double spermatogenesis is obtained by a heterotypic mitosis produced in the course of development.—A. Pézard: The idea of the "seuil différentiel" and humoral interpretation of the gynandromorphism of the bipartite birds. In these birds the plumage is divided into two parts following the plane of symmetry of the body, one half having a male appearance, the other female. The reproductive organs show corresponding peculiarities.—A. Desgrez, H. Bierry, and F. Rathery: A balanced food regime and diabetic acidosis.—Pierre Goy: Microbial physiology and the accessory growth factor. It appears to be impossible to determine Vitamine B by studying its action on the growth of yeast.—Charles Lebailly: The duration of the contagious period in aphthous fever.

## CAPE TOWN.

Royal Society of South Africa, May 17.—Dr. J. D. F. Gilchrist, president, in the chair.—J. R. Sutton: The control of evaporation by the temperature of the air. The rate of evaporation from the surface of the water in a metal gauge sheltered by a louvered screen increases as the air temperature rises above that of the water. In the space just above the water the relative humidity is much higher than, while the temperature there is about the same as, that of the free air. The results illustrate the general law that water vapour diffuses along the relative humidity gradient.—Sir Thomas Muir: Note on a determinant with factors like those of the difference-product.—J. Moir: Colour and chemical constitution, Pt. XVII. The azo dyes and other monocyclic colours. By spectrophotographic means, and replacing N by CH and eliminating N or CH, the azo dyes are calculable from oxy- and amino-benzaldehyde, previously calculated in Pt. XIII. Quinone and its imines all have six bands, one pair for neutral, another pair for acid, and a third pair for alkaline solution.

## Official Publications Received.

The Carnegie Foundation for the Advancement of Teaching. Bulletin No. 16: Education in the Maritime Provinces of Canada. By Wm. S. Learned and Kenneth C. M. Sills. Pp. iv+50. (New York.)

Department of the Interior: United States Geological Survey. Bulletin 726-E: Geologic Structure of Parts of New Mexico. By N. H. Darton. Pp. vii+173-275. (Washington: Government Printing Office.)

Classified List of Smithsonian Publications available for Distribution, April 15, 1922. Compiled by Helen Murray. (Publication 2670.) Pp. vi+30. (Washington: Government Printing Office.)

Department of the Interior: United States Geological Survey. Professional Paper 129-G: The Flora of the Woodbine Sand at Arthurs Bluff, Texas. By Edw. W. Berry. Pp. 153-181. Professional Paper 129-H: Geology of the Lower Gila Region, Arizona. By Clyde P. Ross. Pp. 183-197. Professional Paper 129-I: The Flora of the Cheyenne Sandstone of Kansas. By Edw. W. Berry. Pp. 199-225. (Washington: Government Printing Office.)

Smithsonian Institution: United States National Museum. Contributions from the U.S. National Herbarium. Vol. 22, Part 6: Grasses of British Guiana. By A. S. Hitchcock. Pp. x+439-515. (Washington: Government Printing Office.)

Cornell University Agricultural Experiment Station. Memoir 46: A Classification of the Cultivated Varieties of Barley. By R. G. Wilson. Pp. 363-466. Memoir 49: The Biology of Ephydra Subopaca Loew. By Chih Ping. Pp. 555-616. Memoir 50: The Relative Growth-promoting Value of the Protein of Coconut Oil Meal, and of Combinations of it with Protein from various other Feeding Stuffs. By L. A. Maynard and E. M. Franda. Pp. 617-633. Memoir 51: The Hoz Loew, Hematophagus Suis Linné: Its Biology, Anatomy, and Histology. By Laura Florence. Pp. 635-743. Memoir 52: Studies in Pollen, with Special Reference to Longevity. By H. E. Knowlton. Pp. 745-793. (Ithaca, N.Y.: Cornell University.)

## Diary of Societies.

FRIDAY, JULY 7.

ROYAL SOCIETY OF MEDICINE, at 5.—Dr. A. F. Hess: The Effect of Light in the Prevention and Cure of Rickets.

TUESDAY, JULY 11.

INTERNATIONAL NEO-MALTHUSIAN AND BIRTH CONTROL CONFERENCE (at Kingsway Hall, Kingsway, W.C.2), at 10.—Dr. C. V. Drysdale: Presidential Address.—At 2.30.—Dr. Jane L. Hawthorne: Birth Control as it affects the Poor.—E. Cecil: C3 Motherhood.—Mrs. B. I. Drysdale: The Individual and the State.—Miss F. W. Stella Browne: The Feminine Aspect of Birth Control.—Dr. Frances M. Huxley: Birth Control from the Point of View of a Woman Gynaecologist. SOCIETY FOR THE STUDY OF ISBERIETY (at 11 Chaudos Street, W.1), at 8.—C. J. Bond: The Influence of Hospitals on Temperance Reform (Presidential Address).

WEDNESDAY, JULY 12.

INTERNATIONAL NEO-MALTHUSIAN AND BIRTH CONTROL CONFERENCE (at Kingsway Hall, Kingsway, W.C.2), at 10.—Dr. C. V. Drysdale: The Criterion of Overpopulation.—Dr. B. Dunlop: A Malthusian View of Death Rates and of the Average Duration of Life.—Prof. K. Wickless: The Crux of Malthusianism.—Prof. R. Michels: Emigration and the Birth Rate.—Eaton Kelchik Ishimoto: The Population Problem in Japan.—A. M. Catt Saunders: The Historical Aspect of Birth Control.—Prof. E. Punke: Birth Control and Organised Labour.—At 2.30.—Moral and Religious Section. FELLOWSHIP OF MEDICINE (at Royal Society of Medicine), at 5.—Prof. A. H. Todd: Surgery in Rheumatoid Arthritis.

THURSDAY, JULY 13.

INTERNATIONAL NEO-MALTHUSIAN AND BIRTH CONTROL CONFERENCE (at Kingsway Hall, Kingsway, W.C.2), at 10.—Prof. E. W. MacBride: Birth Control and Biological Law.—M. Pollock: The Problem of the Unit.—Prof. W. F. Wilcox: Economic Competition between American Races, Negro and White.—Miss Mary Winsor: The Cost to the State of the Society of Handicapped and the Socially Unit.—Prof. P. W. Whiting: Relation of Recent Advances in Genetics to the British Control Programme.—Dr. H. Hart: Differential Fertility in Iowa.—Prof. K. Dunlap: Psychological Factors in Birth Control.—At 2.—H. Cox: International Aspects of Birth Control.—Dr. A. Nystrom: Overpopulation of the Earth and Its Dangers.—J. O. P. Bland: The Far Eastern Population Question.—Mrs. Anne Kennedy: Birth Control in the United States.—Prof. Isao Abe: The Birth Control Movement in Japan.—Dr. F. Goldstein: Birth Control the Saving of Civilisation.

FRIDAY, JULY 14.

INTERNATIONAL NEO-MALTHUSIAN AND BIRTH CONTROL CONFERENCE (at Kingsway Hall, Kingsway, W.C.2), at 10.—Dr. C. K. Millard: Birth Control and the Fertility Question.—Dr. A. Nystrom: The Necessity for abolishing Laws against Preventive Measures.—Dr. H. Rohleder: Neo-Malthusianism from the Medical Standpoint.—Dr. D. R. Hooker: Effect of X-rays upon Reproduction in the Rat.

## PUBLIC LECTURE.

WEDNESDAY, JULY 12.

ROYAL SOCIETY OF MEDICINE, at 5.—Prof. H. S. Birkett: The Development of Trans-Atlantic Rhino-Laryngology (Sermon Lecture).

# NATURE

A WEEKLY ILLUSTRATED JOURNAL OF SCIENCE.

*"To the solid ground  
Of Nature trusts the mind which builds for aye."*—WORDSWORTH.

No. 2750, VOL. 110]

SATURDAY, JULY 15, 1922

[PRICE ONE SHILLING

Registered as a Newspaper at the General Post Office.]

[All Rights Reserved.]

## NEW OPTICAL LANTERN ATTACHMENT

PROJECTION POLARISCOPE  
MICROSCOPE & SPECTROSCOPE.

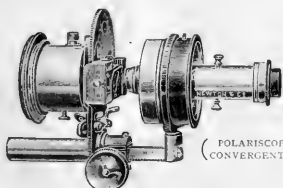

(POLARISCOPE WITH  
CONVERGENT SYSTEM.)

Write for Catalogue, Section "G."

**NEWTON & CO.,**

Specialists in Optical Projection Apparatus,

72 Wigmore Street,  
LONDON, W.1.

## REYNOLDS & BRANSON, LTD.

LABORATORY FURNISHERS AND MANUFACTURING CHEMISTS.

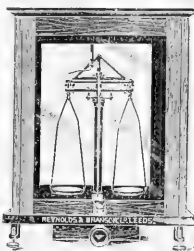

**Balance, Analytical, Rystos**  
New Model. Improved vertical  
movement of rider hook, rider scale  
running from end to end of beam and  
plumb line. The bearings are agate  
throughout; the beam of hard  
magnalium. Base of black crystal.  
Mahogany case with counterpoised  
front, hinged side doors and sliding  
back and brass levelling screws. To  
carry 200 grammes, sensitive to 1th  
milligramme, or 1/16th milligramme  
with a less load . . . . £14 14 0

Balances renovated and repaired in our own Workshops.

For Analytical and other Balances and Weights, see special Catalogue  
Post Free on request.

14 Commercial Street, Leeds.

## BAIRD & TATLOCK (LONDON) LTD.

SCIENTIFIC INSTRUMENT MANUFACTURERS  
and LABORATORY FURNISHERS.

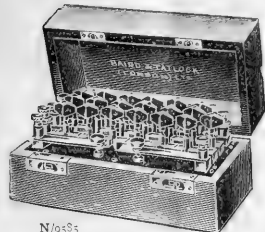

N/9455  
RESISTANCE BOX

Physical  
Apparatus  
for  
Schools  
and  
Colleges.

14-15 CROSS STREET HATTON GARDEN LONDON E.C.1

## HOLIDAY BINOCULARS

We have over 40 different Prism  
models, and many second-hand pat-  
terns in stock. Ask for price list  
"B.N.," or for a selection on approval.

**NEGRETTI & ZAMBRA**  
38, HOLBORN VIADUCT, E.C.1.  
LONDON.

## SCHOOL OF GARDENING AND NATURE STUDY.

CLAPHAM, near WORTHING.

Principal, Miss C. CRACKNELL, N.D. Hort., late of Swanley Horticultural College,  
Miss F. COLLINS.

PRACTICAL and THEORETICAL TRAINING in GARDENING; Fruit, Vegetable, and Flower Growing; Glasshouse and Frame Work. Course of two years; Poultry; Dairy Work; Bees. Preparation for R.H.S. Examinations.

## TO SCIENTISTS, RESEARCH STUDENTS, AND SCHOLARS.

### THE INTERNATIONAL BIBLIOGRAPHICAL SERVICE BUREAU

supplies complete Continental and American bibliographies on any scientific, literary, or medical subject. Medical work a speciality. Extracts made.  
Headquarters: Vienna. English representative: "ALEXANDRIAN," 1A Longridge Road, Earl's Court, S.W.5.

## CIVILIAN EDUCATIONAL STAFF. ROYAL AIR FORCE.

Applications are invited for vacant appointments as EDUCATION OFFICERS, Grade III, and Grade IV., on the Educational Staffs of the undermentioned establishments:

Boys' Wing, Royal Air Force, Cranwell, near Sleaford, Lincolnshire . . . . .	Grade III.
No. 1 School of Technical Training (Boys), Halton, near Wendover, Bucks . . . . .	Grade III.
Electrical and Wireless School, Flower Down, near Winchester (Airmen and Boys) . . . . .	Grades III. and IV.
School of Technical Training (Men), Manston, near Ramsgate . . . . .	Grades III. and IV.
R.A.F. Depot, Uxbridge (Airmen) . . . . .	Grades III. and IV.

The Salary scales, to which Civil Service Bonus will be added, are given below. These scales are provisional and are now being reconsidered. Allowances up to ten increments of the scale can be made for previous experience and war service. Preference will be given to candidates who have served as commissioned officers in any of the three Services. The principal subjects of instruction are English, Practical Mathematics, Applied Mechanics and Drawing.

Grade III. (Graduate) £150-£10-£200-£15-£35 . . . . .	With current Civil Service bonus, approximately . . . . .	£274-£533.
Grade IV. £110-£10-£175 . . . . .		£214-£430.

Applications must be made on A.M. Form 69, which, together with further particulars, can be obtained from the SECRETARY, A.E., AIR MINISTRY, Kingsway, London, W.C.2.

## ROYAL NAVY.

APPLICATIONS are invited for APPOINTMENTS as INSTRUCTOR LEUTENANTS in the Royal Navy.

Candidates must be under 30 years of age, have had a University Training, and have taken an Honours Degree in Mathematics, Science or Engineering.

Present rates of pay are from £365 per annum on entry to a maximum of £945 per annum as Instructor Commander.

Promotion, by selection, to Instructor Captain is also open, with a maximum of £1,277, 10s. per annum.

Retired pay may be granted to Officers over 40 years of age, with a minimum of 12 years' service, up to a maximum of £450 a year for an Instructor Lieutenant Commander, £600 a year for an Instructor Commander, and £700 for an Instructor Captain, according to age and service.

Service victualling, cabin accommodation, and servant are provided, or allowances in lieu.

An allowance of £50 towards the provision of necessary uniform is payable on satisfactory completion of probationary service.

For further particulars apply in the first instance to the SECRETARY OF THE ADMIRALTY, Whitehall, S.W.1.

## UNIVERSITY OF SYDNEY. NEW SOUTH WALES, AUSTRALIA. CHAIR OF ZOOLOGY.

Applications are invited for the above position. Salary (fixed), £1100 per annum, and £120 allowed for travelling expenses to Sydney from Europe. Duties commence March 1, 1923.

Further details of terms of appointment may be obtained from the undersigned, to whom applications (in sextuplicate), stating age and qualifications, accompanied by reference and copies of testimonials, should be sent not later than Thursday, August 31, 1922.

AGENT-GENERAL FOR NEW SOUTH WALES.

Australia House, Strand, London, W.C.2.  
July 5, 1922.

**WOMEN TEACHERS OF SCIENCE,** chiefly BOTANY, required for GIRLS' HIGH SCHOOLS in SOUTH AFRICA and NEW ZEALAND. For full details of vacancies apply to the SECRETARY, S.O.S.E.W., 3 and 4 Clements Inn, W.C.2.

## UNIVERSITY OF CAPE TOWN.

### CHAIR OF INORGANIC CHEMISTRY.

Applications are hereby invited for the CHAIR of INORGANIC CHEMISTRY at the University of Cape Town, which will be vacant from March 1, 1923.

The salary for a man is £500 per annum.  
The Professor must become a member of the University Teachers' Superannuation Fund.

Appointments are generally restricted to candidates under 35 years of age, but in the case of a candidate who has been engaged in teaching or in research in South Africa this restriction need not apply.

Applications (six copies) must reach the SECRETARY, Office of the High Commissioner for the Union of South Africa, Trafalgar Square, London, from whom further particulars may be obtained, not later than July 31, 1922.

The successful applicant will be required to assume duty on March 1, 1923.

## UNIVERSITY OF BIRMINGHAM. FACULTY OF MEDICINE.

### PROFESSORSHIP OF PATHOLOGY.

The Council of the University invites APPLICATIONS for the CHAIR of PATHOLOGY, vacant by the resignation of Professor SHAW DUNN.

The stipend offered is £1000 a year.  
Applications (12 copies) may be accompanied by testimonials, references, or other credentials, and should be received by the undersigned, on or before August 7, 1922.

Further particulars may be obtained from

GEO. H. MORLEY, Secretary.

## MUNICIPAL TECHNICAL COLLEGE, SWANSEA.

Applications are invited for the post of FULL-TIME LECTURER in each of the following departments: Mathematics, Physics, Chemistry, Metallurgy, and Engineering (Electrical).

Salary in accordance with the Burnham Scale.  
Further particulars may be obtained from the undersigned, to whom applications, together with copies of three recent testimonials, must be forwarded not later than July 19.

T. J. REES, Director of Education.

Education Offices, Swansea,  
June 23, 1922.

## UNIVERSITY OF ABERDEEN.

### LECTURESHIP IN BACTERIOLOGY.

Applications are invited for the post of LECTURER in BACTERIOLOGY within the DEPARTMENT of PATHOLOGY.

Salary, £600 per annum.

Federated Superannuation System for Universities compulsory.

Applications, together with full statement of qualifications, age, and 16 copies of not more than three testimonials, to be lodged before July 31, 1922, with the SECRETARY to the UNIVERSITY, MARISCHAL COLLEGE, ABERDEEN.

H. J. BUTCHART, Secretary.

## UNIVERSITY OF LONDON, UNIVERSITY COLLEGE.

### DEPARTMENT OF PHYSICS.

Applications are invited for the post of ASSISTANT in the DEPARTMENT of PHYSICS, under Professor Sir WILLIAM DRAGG.

Commencing salary, £200.

Particulars may be obtained on application to:—

WALTER W. SETON, M.A., D.Lit.,  
Secretary.

University College, London,  
Gower Street, W.C.

## LEEDS UNIVERSITY.

### DEPARTMENT OF CIVIL AND MECHANICAL ENGINEERING.

The UNIVERSITY COUNCIL will shortly proceed to the appointment of a DEMONSTRATOR in MECHANICAL ENGINEERING. Works experience in addition to good academic qualifications essential. Salary, £350. Further particulars may be obtained from the REGISTRAR, the University, Leeds, by whom applications will be received up to July 24.

## DERBY TECHNICAL COLLEGE.

An ASSISTANT LECTURER and DEMONSTRATOR in CHEMISTRY will be required in September next. Good qualifications essential. Burnham scale. Forms of application may be obtained from the PRINCIPAL.

F. C. SMITHARD,  
Secretary to the Derby Education Committee.



SATURDAY, JULY 15, 1922.

## CONTENTS.

	PAGE
Specialisation in Universities	65
More Light on the Bantu Languages. By Miss A. Werner	67
Chemistry and Medicine. By Prof. George Barger, F.R.S.	69
The Hegelian Method and Modern Science. By H. W. C.	70
Soaps and Proteins	70
Commercial Metallurgy. By H. C. H. C.	71
Scientific Activities in the United States: A Biologist's View	72
Our Bookshelf	73
Letters to the Editor:—	
Interspecific Sterility.—Dr. W. Bateson, F.R.S.	76
Geology and the Nebular Theory.—Prof. J. Joly, F.R.S.; W. B. Wright	76
Wegener's Displacement Theory.—Philip Lake	77
Opalescence Phenomena in Liquid Mixtures.—Prof. C. V. Raman	77
Transcription of Russian Names.—Maj.-Gen. Lord Edward Geichen, K.C.V.O.	78
The Influence of Science.—Sir G. Greenhill, F.R.S., The Editor	78
Science and Education at South Kensington. ( <i>Illustrated</i> ). By T. Ll. Humberstone	79
Dark Nebulae. By Prof. H. N. Russell	81
The Corrosion of Ferrous Metals. By J. N. F.	83
Obituary:—	
Ernest Solvay. By John I. Watts	84
The Hon. V. A. H. H. Onslow	85
Dr. A. R. Willis. By A. R. R. and G. W. C. K.	85
Current Topics and Events	87
Our Astronomical Column	89
Research Items	90
Annual Visitation of the National Physical Laboratory	92
Agricultural Research in Great Britain	93
The Magnetic Work of the Carnegie Institution. By Dr. C. Chree, F.R.S.	94
New Social Coleoptera. By Dr. A. D. Imms	95
Spectroscopic Studies of Stellar Velocities. By Dr. William J. S. Lockyer	95
Geology of Antarctic Lands. By G. A. J. C.	96
Durability of Optical Glass. By Dr. James Weir French	97
Volcanic Activity in Nigeria	97
University and Educational Intelligence	98
Calendar of Industrial Pioneers	99
Societies and Academies	99
Official Publications Received	100
Diary of Societies	100

Editorial and Publishing Offices:

MACMILLAN &amp; CO., LTD.,

ST. MARTIN'S STREET, LONDON, W.C.2.

Advertisements and business letters should be addressed to the Publishers.

Editorial communications to the Editor.

Telegraphic Address: PHUSIS, LONDON.

Telephone Number: GERRARD 8830.

NO. 2750, VOL. 110]

## Specialisation in Universities.

IT is not the function of a university to make provision for teaching all the sciences; still less is it the function to confine its work to one narrow branch of specialised study. In one case, apart from the difficulties inherent in such an aggregation, the financial cost would be prohibitive; in the other, a limitation of such a nature would be wholly alien to the modern conception of a university, where, in place of the breadth and proportion of view which comes from the attrition of minds engaged in diverse studies and pursuits, would be found the narrowness and exclusiveness of intellectual segregation. We may therefore dismiss one extreme as impracticable and the other as undesirable.

The universities of to-day have many subjects of study in common. Happily the freedom to develop according to their own individualities, which has hitherto been their lot, has resulted in certain characteristic differences. It is devoutly to be hoped they may not lose these distinctions. The studies common to all universities form a broad humanistic and scientific foundation which is the basis of the intellectual life of the university. Superimposed upon this are the more highly specialised studies, which may in some cases cover a very narrow field, but not seldom form a department in the university linked up in innumerable ways with one or more branches of industrial or commercial life outside. This development has been gradual and, in general, continuous, and it is due to a variety of causes of which probably the two most effective may be defined as historical and regional or environmental. As matters now stand, some studies have already been specialised in certain of the universities and, until quite recently, largely by a process of natural development. To overlook or to underestimate the importance and bearing of this fact would be a mistake.

If the universities were self-supporting or mainly so, it is unlikely that the present system, which on the whole has worked well, would be challenged—it may yet prove to be the best in any circumstances—but since they are not self-supporting, and since they are coming to rely more and more upon assistance from State funds and local rates, they need not be surprised if a time comes when a critical eye is turned upon their activities. Such a time is with us now. The cry for economy, the reduction in the Government grant, the threat of lean years ahead, apart from other considerations, have brought to the forefront the question of the overlapping of university studies, and the possibility of better co-ordination and co-operation of the universities in the future, especially with regard to

the ever-increasing expansion and development of technology and applied science.

With regard to the question of overlapping it should be remarked that at the recent conference in London of the Universities of Great Britain and Ireland, no statement was more generally applauded than that of Prof. Ripper, of Sheffield, who reminded the conference and the public that at present there was no unnecessary overlapping in university studies. Overlapping there may be, but whether this is unnecessary and wasteful is quite another question and one which cannot be answered by mere statistics. This is where co-operation would be most useful both now and in the future. The Minister of Education was on sound lines when, in addressing the conference, he advised the universities to take counsel with one another and husband their resources. Possible wastefulness due to overlapping ought not to be disregarded at any time and most certainly not at a time of financial stringency.

If, for example, each university were to attempt to cover all the main branches of technology, though perhaps the demand for university-trained technologists in a particular field did not reach a score annually, then disappointment and ineffective work must be the result. Obviously where the demand for trained technologists in a particular subject is limited to a comparatively small number, there is distinctly a case for specialising the study in one university. How far universities would attempt to compete with one another in such cases it is difficult to say. But it is worth recalling that, at the conference to which we have already alluded, Mr. Fisher directed attention to the public-spirited action of the University of Leeds a few years ago when glass technology was proposed as a subject for university research. It appears that either Leeds or Sheffield might have been the seat of the new department, but after a conference Leeds agreed to the new work being centred in Sheffield on the ground that the Yorkshire glass industry as a whole was more accessible from there than from Leeds. The method of procedure by conference should be noted.

Cases such as this are obviously cases for specialisation and are perhaps not difficult to settle. It would seem that the limited demand points to concentration and the "regional pull" to the particular university. On the other hand such highly specialised subjects as technical optics, oceanography, hydro-electrics cannot be said to have so localised a regional pull, nor Chinese, Assyriology, and a host of others. Again, departments of study connected with agriculture, forestry, leather industries, dyeing, textile industries, metallurgy, fuel and coal gas industries are already established in one

or more of our universities. If, as is more than likely, any further specialisation of studies is to be made in these departments, especially if it involves considerable expense, obviously there would arise an occasion for co-operation among the various universities interested with the view of suitable distribution of the work.

So far we have been considering the subject of specialisation in universities from the point of view either of the more highly specialised studies or of technology or applied science generally, and have indicated our opinion that in these fields there will be ample scope and real necessity for co-ordination and co-operation. But there is another aspect of the problem which is apt to be overlooked or even in danger of being confused with the one just considered. It has relation to those basic humanistic and scientific studies which are the foundations of the intellectual life of the universities. Among them are included such subjects as the classics, English, history on one side, and mathematics, physics, chemistry on the other. They are found in all our universities, and rightly so, and so long as the university is conceived as "a spirit, a principle of life and energy, an influence . . . caring for the spirit and mind of man, regardless of considerations of utility," so long will they remain there. While, therefore, it is not disputed that the more fundamental of them should be taught in every university, it may be urged in the interests of a specious economy that the prosecution of research in them should be specialised in certain universities. This, we believe, would be a most dangerous principle to adopt, and would be quite contrary to the true spirit of the university. The effect upon the teaching would be little short of disastrous. In its Report of 1921 the University Grants Committee is clear that "sufficient leisure to pursue research is as essential as adequate remuneration," and that "no institution claiming university rank can rest content while it fails to provide opportunities for the advancement of knowledge, nor can junior teachers hope to rise in their profession or indeed carry out their teaching duties efficiently unless such opportunities are open to them." This extract amply confirms the general opinion expressed at the second Congress of the Universities of the Empire, 1921, regarding the great importance and value of research to a university teacher. Without research behind him a university teacher fails in the freshness, mastery, and inspiration required of a good teacher of university students. Whenever such fundamental studies are found in a university some opportunities for research in them should be provided. This may mean overlapping, but it is not overlapping involving wastefulness.

The case is almost equally strong for a subject which, while not absolutely fundamental in the sense indicated above, is necessarily included in the studies of a university for regional or local reasons. If it is argued that the undergraduates might travel to another university for the necessary instruction, it may be replied that in most cases it would be inconvenient and expensive and not seldom impossible. Assuming that the subject is taught in the university, the arguments adduced above show conclusively that opportunities for research are indispensable. A possible alternative would be to bring a teacher from another university to give a course of instruction in it. This is a plan which, though it has been adopted with good results in some universities, is not always possible or desirable. One can picture a case, in economics for example, where investigations into local conditions are absolutely necessary for the proper development of the teaching of the subject, and no substitute can adequately replace it.

While we are sensible of the need for economy and the avoidance of all unnecessary overlapping in our universities, we are also sensible of the wonderful developments which have taken place in higher and specialised studies in the few decades during which the modern universities have come into being and attained some degree of maturity. It may well be said that "not since the monastic period of the twelfth century, or the scholastic revolution of the sixteenth, has England known an educational movement so rich in romance, in courage, in devotion, and in promise." This extraordinary expansion and development, which has changed the whole face of education in England, is one of self-development untrammelled by vexatious restrictions. The modern university has developed under the wing of the State; it can no more dispense with Government assistance than it can with its students or staff. But if it is to fulfil its rightful destiny it must retain its freedom to develop from within. By all means let there be co-operation and co-ordination among the various universities, just as there are within the university itself. But if, unhappily, any attempt to lop or prune activities, hitherto self-determined, were to succeed, the measure of its success would be the measure of the nation's loss.

### More Light on the Bantu Languages.

*A Comparative Study of the Bantu and Semi-Bantu Languages.* By Sir Harry H. Johnston. Vol. 2. Pp. xii + 544. (Oxford: Clarendon Press, 1922.) 3s. 3s.

AFTER numerous and vexatious delays, the second volume of this monumental work has at last seen the light. It contains "an analysis and com-

NO. 2750, VOL. 110]

parison of the phonology and word-roots and a comparative examination of the syntax of the Bantu and Semi-Bantu languages, together with the conclusions to be derived from this evidence." In accordance with this plan we have, first, a review of the various groups of Bantu and Semi-Bantu languages, following the arrangement adopted in the first volume. (An alphabetical index of languages, by the bye, would greatly facilitate research, though the student is helped to a considerable extent by the table on pp. 2-13. In vol. 1, those not gifted with a remarkable memory for numbers had to turn over the pages till they found the particular language required.)

The classification adopted is open to some objections in detail—as was almost inevitable in the circumstances: but one had hoped to see some outstanding inaccuracies corrected in vol. 2, e.g. the treatment of the two distinct languages Lala and Lamba as one and the same. This, of course, is due to Madan, the only authority accessible when the vocabularies were prepared; but other sources of information have since become available. Again, there is some confusion (vol. 1, p. 281, vol. 2, p. 79) as to the languages entered under 70: Chopi, to adopt the ordinary orthography, is a distinct language from Tswa, and also, we believe, from Lenge, which, again, is not the same as Hlengwe. (See e.g. Junod's map in the "Grammaire Ronga.") Sir Harry Johnston dissents from this writer's view, but it is supported by good recent authority.)

The paragraphs dealing with "Group T: the Zulu-Kafir languages" contain several points calling for discussion. It is surely by an oversight that the palatal click (*q̣*, *ɕ*) is said to be "confined mainly to Zulu and Sesuto." It does not occur in Zulu, and only doubtfully in Xosa. (Bleek: "*Vide* Boyce-Davis, p. 4, where the *q̣* is probably intended to indicate this sound.") The fact that it is found in Sesuto is interesting, as showing that it was probably borrowed direct from Hottentots or Bushmen—not, as usually assumed, from the Zulus. The same paragraph contains a somewhat perplexing assertion: "In Zulu the employment of clicks instead of diminishing is extending, through the same spirit of tribal self-assertion as may be met with in the Basuto. Whenever a present-day Zulu or even a Kafir" (why "even," seeing that click-words are more numerous in Xosa than in Zulu?) "wishes to coin a new word—and they are doing this on an immense scale—he nearly always introduces a click into it. . . ."

It is difficult to check statements of this kind unless one is in constant touch with natives, but a rough test may be made by consulting the list of neologisms at the end of Colenso's Dictionary (edition of 1905, pp. 721-724). Among 236 words we find only three

containing clicks, and two of these—*isigqoko* "hat" (adapted from *isigcogo* "head-ring"), and *uTixo* "God"—are not of very recent introduction. As, however, it may be objected that great linguistic changes may take place in seventeen years, we have examined a copy of the native newspaper, "*Ilanga las' e Natal*," dated February 17, 1922, and find, in two columns, averaging about 175 words each, 31 clicks, excluding repetitions and proper names. Of these, all, with the possible exception of three (two of which may be wrongly printed), are either to be found in Colenso's Dictionary, or are obvious derivatives of words there given.

It is strange to see *-gundu-* "rat" given as peculiar to the Swazi dialect, when *igundane* is very commonly used in Natal Zulu. Similarly, on p. 86, we have, *apropos* of the Sesuto *-liba* " (deep) water," the note, "This is a very interesting penetration far to the south of the Zambezi of a root which is very archaic (*-ndiba* or *-diba*), and particularly characteristic of the N.W. Bantu." But surely it is the same word as the Zulu *isi-ziba*, the Ronga *tiba*, the Swahili *ziwa*, etc.

This survey extends over five chapters and is followed by a similar review of the Semi-Bantu languages, after which we have a highly controversial chapter on phonetics and phonology. The note on p. 215 we may leave to be dealt with by scientific phoneticians, but must protest, in passing, against the dictum that "proficiency in speaking an African tongue exactly as it is pronounced . . . is only to be acquired by a parrot-like imitation of the natives." While "parrot-like imitation" can only be compassed by those possessed of a really good ear, a faultless pronunciation can often be acquired even by persons of inferior ear-capacity, by attending to the instructions of the phonetician. But this presupposes an analysis of the sounds carried out with that meticulous accuracy for which our author appears to entertain so great a contempt. Under the heading "Lingual-palatal-sibilant" (p. 217), no notice is taken of the fact that the symbols *c*, *j* cover at least two different sounds, one of which, the palatal plosive, is not a compound consonant "composed of a blending of *t* and *sh*." The difference is important, because sometimes, as in Chinyanja and Zanzibar Swahili, it serves to discriminate between otherwise similar words. Perhaps, however, this point is covered by what is said on p. 222 as to the palatalising of *d* and *l*. The final paragraph of this section (p. 219) fails to make clear the distinction between sentence-intonation and significant word-intonation.

Sir Harry Johnston seems inclined to agree with Prof. Meinhof as to the probable absence of vowel-roots in Proto-Bantu. "A comparison of all the recorded forms often leads to the deduction that the

oldest root of two syllables commenced with a consonant, very often a guttural." This term is now disused as not sufficiently precise—it would cover velar, uvular, and faucal consonants. It is not quite accurate; however, to say that Meinhof in all cases "replaced the dubious or missing consonant by a gamma ( $\gamma$ )." He sometimes postulates *v* (bilabial *v*) and has left the question open for at least sixteen stems, where he was unable to decide what the primitive consonant could have been. It is not quite easy to see what is meant by the next sentence: "My own researches, however, lead me in restoring the missing consonant to greater definiteness; to a *g* instead of a  $\gamma$ , a *h* instead of an *x*, a labial instead of an aspirate." The fact that the form *γenda*, for instance, is found in a small group of languages (only Shambala and Pare-Gweno, so far as I am aware), while *genda*, *jenda*, and *enda* are common, coupled with the greater difficulty of pronunciation of the voiced velar fricative—a difficulty which seems to be felt very generally in Bantu—seem to indicate that Meinhof may be right here.

The chapter dealing with "Prefixes, Suffixes and ConCORDS connected with the Noun" is of great interest. Sir Harry appears to show convincing reasons why the *fi-* or *pi-* diminutive class (Meinhof's 19th) should be identified with the 8th (*vi-*) instead of maintaining a separate existence. That it is singular while 8 is plural constitutes no objection, since we find 14 (*bu-*) fulfilling a similar double function—or rather being treated as plural in some cases (Luganda, Herero, etc.), while in itself it is, strictly speaking, neither singular nor plural. With this example in view, it seems to us that it would have been more logical to place *fi-*, etc. under 8 without creating for it the special subdivision of 8a. This prefix occurs in Karanga (as noticed on p. 75) in the form *svi-* (or rather *vi-*, with the peculiar "whistling *s*"),<sup>1</sup> with *vu-* corresponding to it as plural.

We should have thought it probable that the "honorific" prefix *ka-* belonged to a different class (now lost as such, but leaving traces, e.g. in Luganda, in such words as *Kabaka*, *Katonda*) from the diminutive (13). There are indications, in Konda, Lamba, and elsewhere, of a class of animals with the prefix *ka-*. Whether this was originally identical with the last-named, or had any connexion with the Chinyanja words beginning with *nanka-* (as *nankabai* "hawk"), is a problem which remains for solution.

It seems a pity to confuse the class of infinitives (verbal nouns) with the locatives in *ku-*, which should properly be Class 17, though no doubt the prefixes had originally the same origin. Words like *kuboko* "arm,"

<sup>1</sup>  $\sigma$  is the International Phonetic Association's symbol for this sound, which (or a similar one) is written by Meinhof  $\xi$  and by Junod  $\xi$ . Sir Harry Johnston has nowhere noticed it.



*kuu* "ear," etc., are locatives which have quite usurped the place of the original noun—usually of Class 5, which accounts for the plural in *ma-* (*maboko*, *matu*)—the locative, as such, having no plural. Similarly, the locative in *mu-* accounts for the appearance of parts of the body in Class 3. An interesting illustration of this is found in Swahili: the Mombasa dialect has preserved the old word for "foot," *guu* 5 (for *li-gulu*), pl. *maguu*, which, at Zanzibar, has become *m-guu* 3 (properly "in the foot"), pl. *miguu*.

It is a little difficult to accept in its entirety the following: "Class 18 [Meinhof's 20] implies 'hugeness,' something 'gigantic,' 'brutal' . . . augmentative in an ugly sense. And Class 19 (*Gu-*) is its plural in Luganda; otherwise the plural applied to *Gu-* is usually *Mi-*." As a matter of fact, the plural *mi-* really belongs to a distinct augmentative class, with the prefix *yi-* or *gi-*; still surviving in Swahili, though now practically indistinguishable from the 5th. The prefix is still traceable with monosyllabic roots, as in *jibwa* and *jitu*—elsewhere (by false analogy) it has been dropped, as in *dege*, augmentative of *ndege*. In Mombasa Swahili, the proper plural prefix of these augmentatives is *mi-*. But these two classes, the Depreciative ("augmentative in an ugly sense") and the Augmentative proper have become hopelessly confused—as shown by the Masaba example, *gumuñdu*, plural *gimindu*.

It is difficult to estimate duly the enormous amount of labour which has gone to the making of this volume, and not least to the collating and cross-indexing the word-roots grouped under the English equivalents, after having been enumerated separately under their several languages. With all criticisms that may be possible as to matters of detail (easily corrected if the criticisms are found valid), this work must remain for many years to come the standard guide to the subject. Nothing else that has yet been attempted gives the same comprehensive view of the whole Bantu family, and its possible relationships to the languages adjoining on the north-west. Perhaps the examination of these Semi-Bantu forms of speech is the most valuable part of the whole; and the discovery of the Homa and Banginda languages (hitherto unsuspected forms of Bantu) in the Bahr-il-Ghazal may help to throw light on a difficult question. A. WERNER.

### Chemistry and Medicine.

*Préparation des médicaments organiques.* Par Ernest Fournéau. Pp. viii + 350. (Paris: J. B. Baillière et Fils, 1921). 25 francs.

ONE of the minor effects of the late war has been the increased production of books on technical chemistry in the allied countries. Dealing with the

manufacture of organic medicinal substances, hitherto very much a field of German activity, there recently appeared in this country a monograph by Barrowcliff and Carr, primarily concerned with industrial processes, plant, and patents. Prof. Fournéau, on the other hand, describes in the book under review the preparation of organic medicaments on a laboratory scale. Here are exact directions for all stages of the synthesis of phenacetine, stovaine, veronal, salvarsan, and many others, starting from common materials; for each step the yield is given, which in the author's experience can be obtained. A student of organic chemistry who has worked through these will have acquired quite as much manipulative skill as he usually obtains from Cohen's "Practical Organic Chemistry" or Gattermann's "Kochbuch," and he will have made more interesting substances.

The preparative directions constitute, however, little more than a quarter of the book under notice. Prof. Fournéau begins with a theoretical section, discussing such diverse matters as the relative costs of different processes of large-scale production, the pharmacological methods for testing antipyretics, the considerations which should govern the search for a new local anaesthetic, the chances of finding a useful organic compound of mercury. Like the practical section, the more theoretical one is excellent, and worthy of the discoverer of stovaine, but in a different way. The precision of the experimental part, with its homogeneity and wealth of detail, may recall to some readers that its author is a pupil of Willstätter. The more theoretical portion, less systematic than many German books, is, on the other hand, eminently readable. We feel that Prof. Fournéau has chosen for review just those topics in which he was really interested; thus we are given admirable accounts of adrenaline analogues, phosphatides and nucleic acids, in excess of their pharmacological importance, and in greater detail than his rapid review of alkaloidal chemistry.

The advice to beginners on the setting-up of apparatus gives an interesting glimpse of the author's personality. "Il faut toujours se préoccuper du montage soigneux et élégant des appareils et y consacrer le temps nécessaire; on le retrouve toujours." The laboratory should be kept like a drawing-room, and Moissan's ideal is quoted that the chemist should be able to work "sans se salir, en habit, en cravate blanche, en escarpins vernis, sur un parquet ciré."

However, the aesthetics of the laboratory do not extend to the printing-office, for Prof. Fournéau's book shows a Latin disregard for Teutonic spelling. Aronsohn (p. 22), Wärmestich (p. 23), Fränkel (p. 57, 229), Fildes (p. 109), Laidlaw (p. 176), Rosenheim,

Tebb, Thudichum (p. 187), Strecker (p. 188), Zeisel (pp. 219-221) are all spelt more or less inaccurately. We do not for a moment suggest that such trivial errors in typography constitute a serious blemish on an admirable work; we mention them rather in illustration of what we believe to be a national peculiarity. Chemical errors seem nearly all to have been collected in a list of errata, but the structural formulæ of quinine (p. 37) and of tryptaflavine (p. 109) still require revision. It is perhaps open to discussion whether quinotoxine (p. 39) can be strictly described as the ketone corresponding to quinine, and whether, in French, phenyl potassium sulphate (p. 236) should really be an "éther sulfonique" (but here we may be getting on dangerous ground).

Prof. Fournau's book should find a place wherever organic chemistry is taught to advanced students. It may be warmly recommended to the pharmacologist as a source of information on the chemistry of his subject. To recommend to technical chemists a book by the former director of the Poulenc laboratories seems superfluous.

GEORGE BARGER.

### The Hegelian Method and Modern Science.

*The Ethical Theory of Hegel: A Study of the Philosophy of Right.* By Prof. H. A. Reyburn. Pp. xx+271. (Oxford: Clarendon Press, 1921.) 8s. 6d. net.

THE "Rechtsphilosophie" was the last of the works published by Hegel in his lifetime. Originally it consisted of the rigorous, consecutively demonstrated, chain of numbered paragraphs, which he used as the framework of his courses of lectures. In the form in which we now know it in the collected edition published in 1833 two years after his death, the editors have added the notes and emendations, the celebrated *Zusätze*, with which Hegel was accustomed to elucidate his theory in lecturing.

Prof. Reyburn in this admirable study which he entitles Hegel's Ethical Theory, deals mainly with the "Rechtsphilosophie" but treats it as a general introduction to the whole philosophy of Hegel. It is doubtful if for the modern student he could have chosen a better way. Hegel had no ethical theory in the technical meaning of the term. His philosophy is ethical theory and his ethical theory is his philosophy. It cannot be otherwise if we once accept the view that the real is the rational and the rational is the real. If there be no realm of existence outside of and indifferent to value there is no need for a transcendental theory of morality like Kant's or a utilitarian principle like Bentham's.

The study of Hegel is of peculiar interest at the

present time, and more especially to those who are conscious of the new methodology of science which is manifesting itself in the most modern mathematical and physical theories. So striking indeed is this that had Hegel's place in the history of philosophy been after instead of before the great scientific achievements of the end of the nineteenth and the opening of the twentieth centuries, it would have been impossible to resist the belief that the Hegelian dialectic had been suggested directly to its inventor by the discoveries of science. What finer illustration of identity in difference, of advance by negation, of the union of opposites in a higher synthesis, is to be found than that afforded by the electrical-theory of matter? There have been repeated attempts since Hegel to reform philosophy by introducing into it what has been called scientific method, but the great reform which we are witnessing to-day is the introduction of philosophical method into science. Its keynote is that the concrete only is real. Science is discovering that there is no means of giving self-hood, consistency, independence, to the abstract, and this is the alpha and omega of the Hegelian philosophy.

Anyone who desires an easy introduction to the thought of this most powerful and yet most difficult philosopher of the modern period may be recommended to read Prof. Reyburn's book.

H. W. C.

### Soaps and Proteins.

*Soaps and Proteins: Their Colloid Chemistry in Theory and Practice.* By Prof. M. H. Fischer and others. Pp. ix+272. (New York: J. Wiley and Sons, Inc.; London: Chapman and Hall, Ltd., 1921.) 24s. net.

THE principal author of the volume under notice, who is a physiologist, states in his preface that he is principally interested in the colloid chemistry of the proteins, that this is too complex for direct analysis, and that therefore he turned to the soaps, as sufficiently analogous to the proteins in their colloidal behaviour to enable one "from the surer ground of the soaps . . . to step over into the more slippery one of the proteins." This view of the possibilities of reasoning by analogy will strike most people as decidedly light-hearted, even in cases where the results to be thus applied are unassailable, a condition which cannot be claimed for the author's views on the nature of soap-liquid systems.

The experimental work described consists in the preparation of a very large number of pure soaps (in the widest sense) and their examination under practically one aspect—their power to form gels with water

and other solvents. The results are used to support the author's theory of the sol-gel transformation, which, according to him, is "a change from what is, at the higher temperature, essentially a solution of soap in water to that which is, at the lower temperature, a solution of water in soap." The methods of physical chemistry are held to be inapplicable to the latter type, and the author is thus relieved of the task of considering the fundamental work of McBain and his school. Various experiments are quoted in support of this gel theory, thus (p. 80): "A drop of phenolphthalein solution dropped upon a 10 per cent. sodium stearate water gel remains uncoloured. If, however, the gel is slightly squeezed (which breaks the encircling hydrated sodium stearate film and squeezes out the enclosed solution of soap-in-water), the spot turns bright red." If any one will take the trouble to put a drop of indicator on an acid or alkaline gelatin gel, he will see it turn without squeezing, so that the behaviour of soap gels is not, as the author claims, typical or universal, nor is it any clue to that of protein gels.

The chapters on proteins are trifling, and analogies like that drawn between the heat coagulation of albumin and the behaviour of a boiled solution of sodium palmitate can scarcely be taken seriously. The author almost throughout dismisses the work of other investigators in the airiest fashion; most strikingly, perhaps, in his chapters on emulsions and froths. Surface and interfacial tensions, adsorption and film-formation are all irrelevant: the decisive factor is a curious and novel physical property of the phases, their "breaking length." An extraordinary feature of the book are the illustrations—half-tones of more than 1300 tubes and bottles containing soap solutions which, at their worst, convey nothing and, at their best, no more than the text. They may in part account for the high price of the book, which is difficult to explain on any other grounds.

### Commercial Metallurgy.

*The Metallurgy of the Common Metals: Gold, Silver, Iron (and Steel), Copper, Lead, and Zinc.* By L. S. Austin. Fifth edition, revised and enlarged. Pp. xviii+615. (New York: J. Wiley and Sons, Inc. London: Chapman and Hall, Ltd., 1921.) 42s. net.

THE first edition of Prof. Austin's book was published in 1907—it has now reached a fifth edition. In his preface the author states that since 1913, the date of the last edition, such radical changes and improvements have been made in the metallurgy of the common metals that the present book has been

largely rewritten to bring it in accord with present-day practice. It is refreshing to come across a book which treats metallurgy as a whole and does not, as is so frequently the case, subdivide it into the so-called ferrous and non-ferrous metallurgy. The practice of differentiating the metallurgy of iron and its alloys from that of the other metals has its origin, of course, in the outstanding practical importance of these materials and the scale on which they are manufactured, but there is no scientific reason for making any distinction of this kind, and indeed, there is little doubt that if there were more interchange of opinion between those engaged in the various metal industries it would be of considerable benefit to all concerned.

The first ten chapters deal with general metallurgy under the headings (1) ores and metals, (2) fuels, (3) refractories, (4) the preparation of ores, (5) crushing, grinding, screening, and classifying, (6) metallurgical furnaces, (7) combustion, (8) metallurgical thermochemistry, (9) roasting, and (10) concentration of ores. Inasmuch as these aspects of metallurgy are compressed into 117 pages, the treatment is necessarily somewhat brief. The author, however, has economised space in not attempting to describe methods not now in use. Compactly as the subjects are dealt with, it would appear that terseness has been carried to an extreme in attempting to describe the concentration of ores by gravity, by concentrating tables, and by oil flotation in three pages, a considerable part of which is occupied with diagrams.

The remainder of the book treats of the metallurgy of gold, silver, iron, copper, lead, and zinc in so far as extraction and refining processes are concerned. No attempt, however, is made to deal with the mechanical treatment of metals, either in the hot or cold state, nor their working up into finished products. One of the characteristic features of American metallurgy is its emphasis on the efficient mechanical handling of the materials used in producing the metals and it is natural, therefore, to find this aspect of the subject well treated. The author's account of the metallurgy of gold, silver, copper, and lead is, on the whole, satisfactory. The metal iron, however, receives something less than its share of credit, for an attempt is made to describe the production of wrought iron in less than three pages. To try to deal with the manufacture of wrought iron without any account of the mechanical treatment necessary, except in the most perfunctory fashion, is certainly unusual. With regard to zinc, it is somewhat curious that, considering the importance of the present-day production of electrolytic zinc, very little more than one page is devoted to it.

The last two chapters give a brief account of plant and equipment and their cost and the business of

metallurgy. A satisfactory feature of the book is the calculation of furnace charges in reference to typical metallurgical operations. As has been generally indicated, the book gives a good, if at times too brief, account of the principal operations involved in the metallurgy of the six metals discussed. It is well printed, particularly well illustrated, and bears evidence of careful and judicious preparation.

H. C. H. C.

### Scientific Activities in the United States: A Biologist's View.

*Universities and Scientific Life in the United States.*

By Prof. Maurice Caullery. Translated by James H. Woods and Emmet Russell. Pp. xvii + 269. (Cambridge, Mass.: Harvard University Press; London: Oxford University Press, 1922.) 10s. 6d. net.

BEFORE the war inter-university exchange of professors was much in vogue as between Germany and America. More recently several exchanges of this kind have taken place between America and France, and Prof. Caullery's book is a result—a very useful result—of one of these exchanges. It gives a remarkably lucid and sympathetic interpretation of impressions received by the writer during a stay of five months in America in 1916, when he filled the post of exchange professor of biology at Harvard and visited many of the principal seats of learning in the United States.

The greater part of the book is devoted to the universities and colleges as centres of research and as providing the environment in which future workers are trained. These institutions have, in general, envisaged as their main task the training and equipment of their students for successful leadership in all branches of social activity; and they have come to recognise that with the incessant extension of the fields of application of science to social needs it concerns them to provide the best possible teaching in applied as well as in pure science. Thus the tendency is for science, as the basis of preparation for practical life, to inspire all the activity of the university.

It is sometimes asserted that the study of science in America is apt to be cramped by an excessively utilitarian bias, and such a bias has undoubtedly characterised the State universities, most of which originated in the "Colleges for Agriculture and Mechanic Arts" established under the Morrill Act of 1862. The policy inaugurated by this Act was one which Congress adopted owing to the refusal of the independent colleges to provide urgently needed

teaching in technology. About the same time the growth of scientific knowledge led to the breaking down of the old uniform curriculum and its replacement by the elective system, and to the organisation of "Graduate Schools" by the more important colleges, which thus became full universities and began to cultivate a spirit of original research. Competition with the new State universities soon led to the abandonment of the attitude of aloofness in regard to applied science and proved beneficial to the interests of pure science, both because the broadening of the basis of studies in the old institutions brought them into closer touch with the nation at large and greatly increased their prosperity and resources, including laboratory equipment, and because the State universities have made, and continue to make, successful efforts towards rivalling the others in the cultivation of scientific research of all kinds.

In this connexion Prof. Caullery is able to elucidate and point his argument by reference to science progress in French institutions, where the Napoleonic system of public instruction has shown itself deficient in adaptability to changed conditions and faculties of science have few points of contact with schools of technology. In America adaptation to their environment is reflected in the remarkable growth shown by the universities and colleges during the past thirty years. The student population of the collegiate and graduate departments has twice doubled within this period, and shows, according to statistics summarised recently in NATURE of April 1, p. 425, no tendency towards abatement of this rate of progress. Buildings and equipment have more than kept pace, their value having increased from 108*l.* to 279*l.* per student, and this is due largely to the enormous development of laboratories which has taken place in all branches of science. Recent visitors to the United States are unanimous in admiring the wealth of material equipment for science teaching and research, and some even describe it as excessive. This development has been made possible by a belief, prevalent among all classes of the community, in the practical value of such work and, especially for the private universities, by the spirit of intense loyalty to the Alma Mater on the part of college graduates. The Harvard rule, that at the twenty-fifth anniversary of graduation each class gives the university a sum of 100,000 dollars, affords an example of the very practical forms in which this spirit manifests itself.

When the Graduate School movement began there arose a demand for facilities for scientific research, and, as this could not at the time be met in America, students resorted to Europe, and found that of European countries, Germany best suited their requirements.

A tradition of Germany's scientific supremacy became firmly established, and for forty years America's most promising young workers, coming under the spell of this tradition, became for life "intellectual subjects of Germany." A reaction had begun to set in before the war, and has acquired considerable force, but the German influence on American science has been profound and its effects will be lasting.

Scientific research is unanimously recognised by American intellectuals as an essential function of the university, but while the material requisites for it have been abundantly supplied, there exist certain other conditions less favourable to its development. Students come up to the university ill prepared as regards both acquisition of knowledge and intellectual discipline. Like many other observers, Prof. Caullery regards secondary school teaching as the weakest part of the American system of education. It is, he says, not merely that the college is burdened with the task of imparting knowledge which should have been acquired in the high school, but that the schools defer too much to the taste, or rather whim, of the pupil. "Americans try to compel the child as little as possible, to present life to it under its most smiling form, to spare it opposition, to make work appear to it under the form of pleasure rather than of duty . . . ; they treat the schoolboy too much like a student, to the detriment of healthy intellectual discipline." The "spoon feeding" which is consequently resorted to in the college (where the student is apt to be treated too much like a schoolboy) is unfavourable to the development of capacity for original work. While this does not prevent the colleges from turning out graduates well qualified to achieve success in life, nor stifle the development of exceptionally gifted individuals, in the average case the college gives "a culture not sufficiently deep to be fertile."

The connexion between the college and the graduate school of the University, in which most of the advanced work in pure science is done, is very close. In all except a few of those universities (about thirty) in which a graduate school has been developed, it has no separate teaching staff: its professors are also those of the undergraduate college, although the work is organised quite separately, and is carried out under the superintendence of the Dean of the school. In most universities, moreover, the college tradition, with its emphasis on athletics and the social side of life, is still dominant. Some high authorities in America who believe that the destiny of the universities is to become primarily great schools of research have urged that the time has come to free the graduate school from this domination. Meanwhile there is a clear tendency to create special institutes for research within

more or less narrow limits, some being established within, or in association with, the universities and others with no such connexion.

As regards the actual contributions to science of American universities, Prof. Caullery notes that in zoology and general biology, the sciences in which he is specially interested, they have produced of late years many very remarkable works. He instances those of Edmund Wilson (cytology), E. Conklin (cell-lineage), R. G. Harrison (experimental embryology), T. H. Morgan (Mendelian heredity and mutations in *Drosophila*), Calkins and Woodruff (*Infusoria*, senescence, etc.), and others.

Scientific activities outside the universities and colleges are dealt with by Prof. Caullery in a series of interesting sketches of the more important of the research institutes, the Carnegie and Rockefeller and other foundations for promoting research, the great museums, the Federal scientific services, and the scientific academies and societies. From the first category the Mellon Institute for Industrial Research may be selected as an example of an establishment for pure research attached to a university—Pittsburgh—but retaining a large measure of autonomy. A manufacturer having a problem to solve turns it over with a definite sum of money to the Institute, which proceeds to engage the services of a man of science and provides the requisite laboratories and equipment. The man of science, who is styled a fellow, conducts his researches in secrecy, and the results are the property of the donor of the subvention. The plan is reported to have worked very successfully.

For an indication of the scale on which scientific research is being fostered by these various bodies (except the Federal services) and by great industrial corporations, one may refer to a bulletin published last year by the National Research Council, now the chief agency for co-ordinating scientific research in America. This bulletin (noticed in *NATURE* of August 4 last) enumerated 170 bodies other than universities and colleges which provided funds for this purpose of the aggregate annual value in 1920 of more than 18 million dollars. The Government (Federal and State) grants for research in agriculture, engineering, and the industrial arts have been estimated to amount to 10 million dollars in 1921.

### Our Bookshelf.

*A Text-book of Wood.* By Herbert Stone. Pp. vii+240+41 Plates. (London: Rider and Son, Ltd., 1921.) 21s. net.

This book deals with the anatomy, physical and mechanical properties, anomalies, defects, and decay of wood. Although intended for "advanced students,"

it abounds in elementary errors as regards facts, botanical and mechanical. For example, the account of the production of wood by cambium is truly fantastic, while the implication is made that when dead wood is absorbing water and swelling, the cells of the medullary rays exert great pressure by reason of their turgidity. But quite inexcusable are misquotations of various scientific workers, including R. Hartig and Mathieu (who is made responsible for the statement that heartwood and sapwood are synonymous "expressions").

Errors as regards matters of fact are matched by the author's methods of reasoning and the conclusions that he draws. According to him the wood-vessels cannot have very important functions, "inasmuch as Conifers do without them." Or, again, he writes of a beam under transverse bending load that "the height may be reduced and yet the beam be stronger"; and in dealing with mechanical tests he not only "hopes and believes" that practical men do not "pay any attention to the figures so far supplied by physicists," but also advises the abolition of "all calculations whatsoever." A number of excellent photographs of wood-structure impart some value to the book.

*Textile Design and Colour: Elementary Weaves and Figured Fabrics.* By W. Watson. Second edition, with an Appendix on Standard Yarns, Weaves, and Fabrics. Pp. xi+436. (London: Longmans, Green and Co., 1921.) 21s. net.

The comprehensiveness of Mr. Watson's training is reflected from the pages of this book. A student in the Textile Industries departments of the University of Leeds and the Bradford Technical College, and successively head of the Textile Departments at Salford and the Royal Technical College, Glasgow, Mr. Watson has naturally produced a volume which is both broad in outlook and sequential in treatment. In the maze of small weave effects, for example, it is so easy to degenerate into mere statement and illustration that any writer who can introduce a sequential and reasonable treatment leading to that imaginative insight, which is so much to be desired in the cloth constructor, is to be congratulated. In the future probably more conventional scientific treatment of the structures here referred to will be necessary, for not only do such matters as combinations and permutations appear, but, as was quite accidentally discovered at the meeting of the Mathematical Association last year, the problem of sateen cloth structure is the problem of atomic grouping in crystal structure.

Mr. Watson's treatment of the colour problems involved in textile designing is by no means so satisfactory: it largely resolves itself into "colour and weave" form. The technical treatment of figured fabrics is excellent, and the appendix upon Standard Fabric should prove very useful to all designers and manufacturers.

A. F. B.

*Principia Ethica.* By Dr. George Edward Moore. Pp. xxvii+232. (Cambridge: At the University Press, 1922.) 15s. net.

THIS volume is the reprint of the famous and much-discussed treatise of Dr. G. E. Moore, the present Editor of *Mind*, which was first published in 1903. Readers

will turn at once with interest to the brief note added to the preface in which the author tells us that he is still in agreement with its main tendency and conclusions. His thesis is that "good" is indefinable, but that "the good" can be defined. The good is the thing, simple or complex to any degree, to which the indefinable predicate good belongs. He illustrates his meaning by an extreme case. He asks us to imagine a world exceedingly beautiful, and then to imagine the ugliest world it is possible to conceive. We are asked, in comparing these worlds, to accept the limitation that "we are not entitled to imagine that any human being ever has, or ever, by any possibility, *can*, live in either." Is it irrational, he asks, to hold that it is better that the one should exist and not the other? To most students of ethics the limitation makes the question nonsense in the literal meaning of the term. It is interesting to find that Dr. Moore can still think it a rational question after the lapse of twenty years. Yet we must admit the force of his logic, for if value is to have any meaning at all to the realist, it can only be by finding some way of attaching it to the object and presenting it in complete abstraction from the subject, for the mind is limited in its activity to contemplation.

*Rocks and Fossils and How to Identify Them.* By J. H. Crabtree. Pp. 63. (London: The Epworth Press; J. Alfred Sharp, n.d.) 1s. 9d. net.

WE have here a book, very prettily illustrated by photographs; but the text is not in keeping with the author's daring statement that "geology is, of all concrete science studies, most exact in its observations and conclusions." The loss of land at Dunwich (p. 14) should not be ascribed to subsidence; faults (p. 18) do not imply that "the two parts are pitched at different angles"; limestones are said to be "generally combined with mineral matter"; Radiolaria are photographed in one of the admirable plates as "flinty shell remains of foraminifera"; and in another plate a very mixed assemblage of fossils, including halysites and Fenestella, is attributed to the Old Red Sandstone. "Interlocking teeth" are given as a characteristic of Labyrinthodon, and Tyrannosaurus is said to have preyed upon the mammoth. We must not dilate on the reappearance of Eozoon and the "Laurentian system," or on the "boreal climate" of the Trias (p. 56). If we interpret his remarks on "sauroid fishes" as referring to Sauripterus, the author has been diligent in his reading, and we must regret that he has shown so little regard for exactitude in "observations and conclusions."

G. A. J. C.

*The Mineral Resources of Burma.* By N. M. Penzer. (Federation of British Industries: Intelligence Department.) Pp. viii+176. (London: G. Routledge and Sons, Ltd.; New York: E. P. Dutton and Co., 1922.) 31s. 6d. net.

MR. PENZER, on behalf of the Federation of British Industries, has undertaken with conspicuous success the task of summarising the information hitherto inconveniently scattered through various unrelated publications concerning the mineral resources of the province of Burma. He has taken care to secure the co-operation of recognised authorities with special

local experience, such as Sir George Scott, Mr. La Touche, and Dr. Coggin Brown; and the result is a reference work of exceptional value to prospectors and commercial men. In addition to precise summaries of the recorded information regarding each mineral occurrence, the book contains a very useful sketch of the physical geography, geology, history, administrative systems and communications of Burma, a full index to the local vernacular names in common use, and a very full, conveniently classified bibliography.

*The Statesman's Year-Book: Statistical and Historical Annual of the States of the World for the Year 1922.* Edited by Sir John Scott Keltie and Dr. M. Epstein. 59th Annual Publication. Revised after Official Returns. Pp. xlvii+1568. (London: Macmillan and Co., Ltd., 1922.) 20s. net.

THE new edition of the "Statesman's Year-Book," which appears earlier than usual this year, maintains all the features that have gained for it a unique place among volumes of reference. The number of independent states has now been increased by the addition of Egypt and Lithuania. Various secession states, the status of which is not yet fully recognised, are still grouped with their parent countries. The organisation of the Irish Free State, together with the full Treaty between Great Britain and Ireland, are given in the introductory pages, which also furnish information on the organisation of the League of Nations and the Imperial and Washington Conferences. While the whole volume has, as usual, been carefully revised, special attention has been devoted to Russia and China. We note some discrepancies in the figures for area and population of the countries detached from Russia, as given under the heading of Russia, and of those countries respectively; but the last census returns in this part of Europe were by no means complete. Two coloured maps show the division of Upper Silesia by the League of Nations and the Burgenland settlement between Austria and Hungary.

*The Annual Register: A Review of Public Events at Home and Abroad for the Year 1921.* Pp. xii+332+180. (London: Longmans, Green and Co., 1922.) 30s. net.

THE scope of the "Annual Register" is well indicated by its sub-title, and a truly remarkable amount of information is gathered together within the covers of the volume. Part 1 consists of some three hundred pages, of which about half are devoted to events of importance occurring in England during the past year: a large portion of this section deals with events in Ireland, culminating with the Peace Conference in London and the signature of the treaty of peace. The remainder of Part 1 is devoted to brief summaries of outstanding events in other countries of the world. Part 2 is of a more general nature and contains, among other items, a retrospect of science during the past year. The section is divided into two parts dealing with the biological and physical sciences respectively, and all outstanding events in the world of science appear to be mentioned.

To cover the ground, the articles are of necessity brief, but the whole is welded together so skilfully that the volume, besides serving as a comprehensive

reference book for world affairs, provides an interesting and readable account of man's activities during the year 1921.

*Cotton Spinning.* By W. Scott Taggart. Vol. II. Sixth edition with Appendix. Pp. xv+291. (London: Macmillan and Co., Ltd., 1921.) 8s. 6d. net.

IT is not surprising that Mr. Scott Taggart's work on "Cotton Spinning" should already be in its sixth edition. Books of this type arrange themselves under one of two heads—either they are "descriptive" or they are "demonstrative": rarely are they both. This work, although by no means void of the "why" and "wherefore" and the "for" and "against," is mainly descriptive. Thus in dealing with the distribution of drafts on pages 259 to 266, "fibre movement" does not seem to have been considered, with the result that even here Mr. Taggart is in difficulties in making theory fit with practice. But the treatment of each section of the subject throughout is so clear and concise that even the very limitations of the treatment stand out clearly and thus are not dangerous. This book should certainly be in the hands, not only of every cotton spinner, but of every spinner of materials of a like nature. A. F. B.

*A History of the Association Psychology.* By Prof. H. C. Warren. Pp. x+328+1 chart. (London: Constable and Co., Ltd., 1921.) 16s.

THE volume under notice, by the well-known professor of Princeton University, contains a great deal of matter which cannot fail to be useful to the student, and it is presented in a serviceable form. It is not, however, as the title would lead us to expect, a history of the movement in mental science which followed the adoption of the empirical principles of Hume and explained knowledge by the laws of association,—a theory often described by its critics as psychological atomism. It is rather an attempt to show that an idea which has no history is to be discovered in all the historical systems of philosophy. It begins with the ancient philosophy of Greece and ends with an account of some of the psychological experiments now being conducted in college laboratories and reported in current journals.

*Lubricating and Allied Oils.* By E. A. Evans. Foreword by Sir Charles Cheers Wakefield. (The Directly-Useful Technical Series.) Pp. xv+128. (London: Chapman and Hall, Ltd., 1921.) Price 9s. 6d. net.

THE greater part of this book is taken up with descriptions of the physical and chemical tests usually carried out on oils with the view of determining their commercial value. Sufficient is given to enable the chemist to carry out these tests in the orthodox manner and to reduce the results. The book should also be of value to the engineer, who must understand the meaning of the experimental results; his requirements are considered in later chapters on the selection of lubricants and oils employed in practice. Most of the existing works on lubrication and lubricants are too comprehensive and technical to be of much service to the user of oils, and the author of the present work is to be commended for the brief and clear account of the principal properties he has presented.

### Letters to the Editor.

[The Editor does not hold himself responsible for opinions expressed by his correspondents. Neither can he undertake to return, or to correspond with the writers of, rejected manuscripts intended for this or any other part of NATURE. No notice is taken of anonymous communications.]

#### Interspecific Sterility.

THE implications of modern genetics have been so little considered by biologists in this country that the criticism of my address by Dr. Cunningham (NATURE, June 17), though in purpose destructive, is not unwelcome. Of the points he raises one chiefly calls for reply. I directed once more the attention of naturalists to the fact that we still await the production of an indubitably sterile hybrid from completely fertile parents which have arisen under critical observation from a single common origin. So far as our knowledge goes, all the domesticated races—for example, of dogs, of pigeons, of fowls among animals; and of cabbages, of peas, of *Primula sinensis*, and many more among plants—when intercrossed among themselves never produce this sterility in their mongrels, though the races are often distinct enough to pass for species. But if we begin crossing natural species, even those which on our reckoning must be very closely allied, we constantly find either that they will not interbreed, or that, if they can be crossed, the result is more or less sterile. Dr. Cunningham takes exception to my speaking of this interspecific sterility as the chief attribute of species, but he will not dispute that it is a chief attribute of species.

The races of fowls might, as he holds, on account of their enormous divergences, be without impropriety compared to natural species. They may also, as he thinks, all descend from *Gallus bankiva* (though I find that difficult to believe); but inasmuch as they do not show interspecific sterility they do not help us to understand how that peculiar property of species arose in evolution. In contemporary variation we witness the origin of many classes of differences, but not this; yet by hypothesis it must again and again have arisen in the course of evolution of species from a common ancestry. The difficulty is no new one; but I emphasised it because naturalists should take it more seriously than they have done hitherto. Especially now that a great deal of experimental breeding is in progress, watch should be kept for such an occurrence. I by no means declare that the event cannot happen, but, so far as I know, it has not been witnessed yet.

Dr. Cunningham tries to fill the gap by adducing two instances. The first is that of *Oenothera gigas*. Now I had not forgotten the tetraploids, which so often do not breed freely with diploids, but the applicability of that example is exceedingly doubtful. Interspecific sterility or incompatibility may well be a consequence of nuclear diversity, though we can scarcely regard an unresolved pair of twins, such as the tetraploid must be, as a specifically distinct organism.

His second illustration, if authentic, would be more nearly what is wanted. He says that "two mutants of *Drosophila* in Morgan's experiments are almost completely sterile with one another." The allusion is probably to a paper of Metz and Bridges (Proc. Nat. Acad. Sci., 1917, iii. p. 673), in which they claimed to have found two mutants of *D. virilis* which gave partially sterile hybrids when intercrossed. Dr. Cunningham is not perhaps aware that this claim

was afterwards withdrawn (Metz, *ibid.*, 1920, vi. p. 421), inasmuch as one of the mutants was found to have been partially sterile. Metz and Bridges did adduce another example in *D. ampelophila*, but for a variety of reasons that, even if substantiated, would scarcely be to the point. As a matter of fact, however, in so far as opportunity of repeating the cross has occurred, complete fertility resulted. I know of no other example to which Dr. Cunningham can be referring.

Mr. Crowther (NATURE, June 17, p. 777) mistakes my meaning. It is, as he says, not difficult to "imagine" interspecific sterility produced by a gradual (or sudden) modification. That sterility may quite reasonably be supposed to be due to the inability of certain chromosomes to conjugate, and Mr. Crowther's simile of the sword and the scabbard may serve to depict the sort of thing we might expect to happen. But the difficulty is that we have never seen it happen to swords and scabbards which we know to have belonged originally to each other. On the contrary, they seem always to fit each other, whatever diversities they may have acquired.

W. BATESON.

July 2, 1922.

#### Geology and the Nebular Theory.

I DO not deserve the reproaches of Prof. Coleman (NATURE, June 17, p. 775). My molten earth did not, in point of fact, owe its thermal energy to primitive condensation, but to accumulated radioactive heat, as the concluding part of my lecture might have shown. I am committed neither to the nebular theory nor to the planetesimal theory.

Had I adopted the wider definition of the Archæan favoured by Prof. Coleman, I could not, of course, have described the Archæan sediments as scanty. I referred to an Archæan limited to the Keewatin, and to the Laurentian outpourings of granitic materials. The Keewatin is generally described as mainly volcanic in origin. The definition of Archæan and Algonkian favoured by Van Hise and Leith (Bulletin 360 of the United States Geol. Survey) would bear me out.

While many geologists would agree with Prof. Coleman as to his estimates of Archæan sediments, many, I think, will disagree with him in his contention that there was nothing exceptional in the thermal conditions attending the Laurentian revolution. Prof. Coleman's most interesting discovery of an ice age in Huronian times has, I submit, nothing to do with the matter. On the other hand, I think geologists in their interpretation of the Archæan should keep in mind the possibility (or probability) that the phenomena observed are due to paroxysmal thermal developments traceable to deep-seated radioactive substances; and that these developments, which appear to have been world-wide in extension, may have been sufficiently intense to have closed a biological era. So that, in fact, we have in the Archæan the almost obliterated record of a prior geological age.

Trinity College, Dublin.

J. JOLY.

I HAVE read with interest Prof. Coleman's timely reminder, in NATURE of June 17, p. 775, of the essentially intrusive relations of the Archæan and of the frequently made deduction that the oldest visible rocks of the earth's surface are sedimentary. Of course this deduction is perfectly sound, provided the age of an intrusive rock is taken, as has been the



custom, to be that of its intrusion. We are entitled, however, to consider the previous history of the material composing these intrusive Archaean masses, and, in view of their predominantly banded structure, which marks them off as in some way different from later intrusive masses of similar composition, such consideration seems forced upon us.

Now the banded character of the Archaean gneiss suggests a partial derivation by melting from some stratiform materials such as sedimentary or volcanic rocks, or at any rate from rocks showing marked small-scale differentiation into basic and acid types. I do not think that stratiform differentiation during or previous to crystallisation can be seriously put forward as a cause of the banding, in view of the rarity of this phenomenon in more recent granites, and the fact that in them it is largely a marginal effect.

May we not then have in these Archaean gneisses the recrystallised remnants of still older sediments and lavas, and who is to say that they may not also embrace portions of the original surface on which water first settled, but so obscured by recrystallisation that the question of its molten or planetesimal origin is now unsolvable?

The difference between the two views is simply that one regards the history of sedimentation on the earth as cut off sharply by intrusion, while the other sees it extending still further back into the mists of the past, beyond the point where human vision is any longer capable of discrimination. Where, on either view, is the decisive criterion between the nebular and planetesimal hypotheses?

W. B. WRIGHT.

Manchester, June 27, 1922.

**Wegener's Displacement Theory.**

WEGENER'S speculations have attracted so much attention that there must be many who would be glad to find some simple means of testing his fittings and coincidences for themselves. Owing to the distortion present in all maps such tests must be carried out on a globe. Wegener himself uses tracing paper, which must be cut and slashed in order that it may even approximately fit the surface; and any one who has tried it will admit that it is difficult to obtain satisfactory results. An easier plan is to roll out a lump of modelling wax or plasticine into a sheet of moderate thickness. The sheet may then be pressed upon the globe and cut to the required shape. According to my own experience, the best method is to cut the sheet a little smaller than the area that is to be represented, so that the actual margin appears all round it, and to build it outwards to this margin by the addition of small pieces of wax. Old plasticine which has become rather dry works very well and does not stick to the globe.

But much more precise tests can be carried out with the help of some form of triangular compasses. The three points of the compasses may be placed on three critical points of the globe and afterwards transferred, without altering their relative positions, to any other part of the globe that may be desired. The ordinary triangular compasses of the draughtsman are very little use upon a spherical surface, but a fairly convenient instrument can be constructed with an ordinary one-jointed two-foot rule as its basis. A point about an inch long is fixed near the joint, and each arm is provided with a sliding carrier. Each carrier bears a short sleeve through which a pointed rod, such as a knitting needle, slides rather stiffly. These rods form the other two points, and all three should stand approximately at right angles to the plane of the rule.

This is an easily constructed type, but much more convenient forms can be devised. If, for example, the arms are arcs of circles, of suitable diameter, so that they may stand concentric with the globe, the points may all be of fixed length, and the most troublesome of the adjustments required by the straight-armed form will be avoided.

This is not the place to discuss Wegener's views, but the use of triangular compasses seems to show that a rather high degree of plasticity is necessary in the masses of "Sial" in order to produce the coincidences on which he bases his calculation of the probability that his theory is correct.

PHILIP LAKE.

Sedgwick Museum,  
Cambridge, June 21.

**Opalescence Phenomena in Liquid Mixtures.**

It is well known that liquids which mix completely above a certain critical temperature, e.g. phenol and water, exhibit a strong and characteristic opalescence as the temperature of the mixture is lowered to a point slightly above that at which the components separate. A quantitative theory of this phenomenon was put forward by Einstein (*Annalen der Physik*, vol. 33, 1910) on the basis of thermodynamical reasoning, the spontaneous local fluctuations of concentration of the mixture being taken into account and the light-scattering due to the resulting fluctuations of refractive index being evaluated. He obtained as the expression for the light-scattering

$$\pi^2(M/N\lambda^4) \cdot v \left( \frac{\partial \mu}{\partial c} \right)^2 / \bar{c} \left( \frac{\log p}{\partial c} \right) \text{ per unit volume,}$$

where  $\mu$  is the refractive index of the mixture and  $\partial(\log p)/\partial c$  expresses the rate of change of the vapour pressure of one of the components with concentration, a quantity which becomes very large as the critical temperature and concentration are approached, thus giving rise to a marked opalescence. It should be pointed out, however, that Einstein's expression does not include the whole effect, for we have also to consider the result of the fluctuation of density of either component taken separately, and to add to Einstein's formula

$$(\pi^2/18)(RT/N\lambda^4) [\beta_1(\mu_1^2 - 1)^2(\mu_1^2 + 2)^2 + \beta_2(\mu_2^2 - 1)^2(\mu_2^2 + 2)^2],$$

where  $\beta_1, \beta_2, \mu_1, \mu_2$  are respectively the compressibilities and refractive indices of the components. Further, the light-scattering due to the anisotropy and arbitrary orientation of the molecules of the components has also to be added.

The result of these corrections of Einstein's investigation may briefly be indicated. Very near the temperature at which the mixture separates into two phases, the fluctuations of concentration contribute by far the larger portion of the effect. But at higher and lower temperatures the effects of fluctuations of density and molecular anisotropy are no longer negligible, and when the temperature is sufficiently removed from the critical point they form a substantial part of the whole. Further, the increase in relative importance of the effect of molecular anisotropy in these circumstances should result in an increase in the proportion of unpolarised light in the transversely-scattered beam as we recede from the critical temperature.

The foregoing indications of theory have been confirmed generally in a series of experiments over a wide range of temperatures on light-scattering in phenol-water mixtures undertaken under the writer's direction by Mr. V. S. Tamma. It is found that the increased opalescence of the mixture over

and above the effects due to the components taken separately can be traced at temperatures far higher than the critical point, and the indicated changes in the polarisation of the scattered light are also easily observed.

It is clear that the case of liquids which are completely miscible at ordinary temperatures stands on the same footing as that of imperfectly miscible liquids above the critical temperature, and the recent observations of W. H. Martin on this point (*Jour. Phys. Chem.*, Jan. 1922) agree with the indications of the theory outlined above.

I may take this opportunity of directing attention to a very important result observed in experiments on light-scattering in liquids conducted by Mr. Seshagiri Rao and the writer. It is found that the molecular anisotropy which results in a scattering of unpolarised light is noticeably a function of the frequency of the incident light. This indicates that the anisotropy is really due to the difference of the optical frequencies of the molecule in different directions, a conclusion which has a bearing on the recent interesting work of Havelock (*Proc. Roy. Soc.*, May 1922). Debye and others have suggested that some molecules possess an appreciable permanent electric moment, and would thus exercise perceptible orienting influences on each other even in the gaseous and liquid states. Indications are already forthcoming that this may exercise an observable influence on the phenomena of molecular scattering of light.

Finally, it may be mentioned that a very carefully carried out series of experiments on the light-scattering in ether, benzene, and normal pentane, over a large range of temperatures above and below the critical temperature, has confirmed quantitatively the Einstein-Smolouchowski theory of molecular scattering of light.

C. V. RAMAN.

210 Bowbazar Street,  
Calcutta, May 25, 1922.

#### Transcription of Russian Names.

MR. DRUCE's letter in *NATURE* of June 17, p. 777, makes little of my typographical objection to a Czech transcription for the names of Russian men of science, by saying that *NATURE* and other journals already employ letters with diacritical marks. For my part, I venture to estimate that not one in twenty English newspapers has Czech type among its founts, or, if it had, would know how to use it in transcription. Are, then, Russian scientific names to be rendered on one system in *NATURE* and on another in almost every other newspaper—or even book? And are Russian scientific names to be rendered differently from Russian literary and musical names—or place-names?

Nobody questions that it is possible, and indeed easy, to transliterate Russian into Czech, all Slavonic tongues being closely akin. But is it more helpful to Britons to render ч by ě than by ch, or u by ě than by ts, even though you save a letter by doing so? (I wonder how many Britons would pronounce this "c" correctly!) Czech journals naturally transcribe Russian names into Czech, but that seems to be no reason why journals in other languages should do so.

Mr. Druce, by the way, ignores my remark that Serbo-Croatian, with its ready-made official system of transliterating Cyrillic into Latin characters, has as good a claim as Czech, if a Slavonic language is to be used for this purpose.

Surely what is wanted in this country to replace the old conventional French and German (and hybrid) forms of Russian names is not a Croat nor a

Czech system, but an intelligible British system of transcription, uniform for all Russian names alike; and this we have ready-made in the R.G.S. II. system (obtainable at any of the geographical book-sellers, or at the Royal Geographical Society). Why not use it?

Royal Geographical Society,  
Kensington Gore,  
London, S.W.7, June 23.

EDWARD GLEICHEN.

#### The Influence of Science.

THE defect of the disappearance of Greek from scientific education makes itself felt in the treatment of the history of science (*NATURE*, June 24, p. 801). The controversy between Galileo and the Inquisition was carried out with pretended hostility, but amicably in reality in the manners of good scientific society, as an academic university disputation on an agreed accepted thesis, taken from Plutarch's "Actia Physica," the source of such disputations as "An *detur vacuum?*" or "*de tempore,*" or whether the tide is due to the influence of the moon.

The Pythagoreans were prepared to maintain against all comers that the sun was the centre of our cosmos, in opposition to the Stoic philosophers; and so on for other subjects of disputation in the University of Athens.

Mr. Lones, of the Patent Office, has retrieved for us at last the passages in "De caelo" and elsewhere, of Aristotle that set Galileo to make a test by experiment, with the two weights dropped from the Campanile of Pisa, of density such as not to be affected appreciably by the resistance of the air. The weights struck the ground with one thud apparently; but if Galileo had thrown himself over after, his thud would have been distinctly later.

Because Aristotle was discussing the terminal velocity of rain and hailstones, or even a meteoric stone, from a height high up in the air, the ascent of a bubble in air, or else in water, compared with a stone sinking; he had no air-pump except his lungs, he could not be certain whether air was really a substance in Nature.

"Don'ts for Students in Science and History," compiled by G. S. Boulger (Tract 74, Catholic Truth Society), should be consulted before accepting the common version of many similar controversial stories. Huxley is quoted, writing to Prof. Mivart in 1885: "I gave some attention to the case of Galileo when I was in Italy, and I arrived at the conclusion the Pope and College of Cardinals had rather the best of it." And so the Inquisition was entitled to a parting shot of jubilation, as it would be again to-day on the doctrine of Relativity.

The rival theories of the Greek philosophers could serve as dialectical exercises till the crucial experiment of the "optic tube of Fiesole"; and here Galileo destroyed all previous uncertainty by his use of the telescope, the most powerful instrument in history for revolutionising the ideas of science.

G. GREENHILL.

Staple Inn, June 27, 1922.

[Fortunately, inability to maintain a scientific thesis before philosophic or other authorities no longer involves such penalties as those to which Galileo was subjected. The whole purpose of the article to which Sir George Greenhill refers was to show that the freedom of experimental inquiry thus secured had far-reaching social and intellectual consequences, and we judge from his last paragraph that he agrees with this view.—EDITOR, *NATURE*.]

Science and Education at South Kensington.<sup>1</sup>

By T. LL. HUMBERSTONE.

A LARGE part of the area shown in the accompanying photograph was at one time Brompton Park, a fine estate famous for its snipe-shooting and for its mild and salubrious air. In 1675 the park became a market-garden, the first of its kind in England. A short distance eastwards was Knightsbridge, an outlying hamlet of London, the scene of frequent skirmishes during the Civil War. Cromwell's associa-

started from Hyde Park Corner at regular intervals in bands for mutual protection, and a bell was rung to warn pedestrians when the party was about to set out. Thus the effective history of the district for our purpose begins in 1851, when the great International Exhibition was opened in Hyde Park. Its initiation and success were largely due to the Prince Consort, and appropriately, therefore, the estate, which was

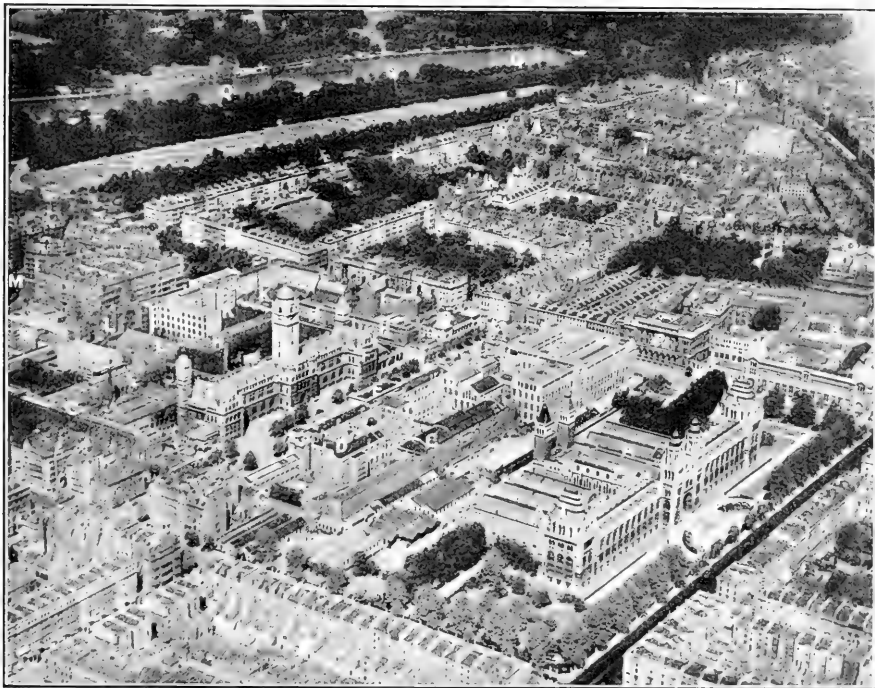

A=NATURAL HISTORY MUSEUM. B=VICTORIA AND ALBERT MUSEUM. C=SCIENCE MUSEUM.  
 D=ROYAL COLLEGE OF SCIENCE (NEW BUILDING). E=SCIENCE LIBRARY. F=IMPERIAL INSTITUTE AND UNIVERSITY OF LONDON.  
 G=ROYAL SCHOOL OF ART NEEDLEWORK. H=INDIA MUSEUM. I=CITY AND GUILDS ENGINEERING COLLEGE.  
 J=ROYAL SCHOOL OF MINES. K=IMPERIAL COLLEGE. L=ROYAL COLLEGE OF MUSIC. M=ROYAL ALBERT HALL.  
 N=ROYAL COLLEGE OF SCIENCE (BOTANY) AND IMPERIAL COLLEGE UNION. O=BROMPTON ORATORY.  
 P=ROYAL COLLEGE OF SCIENCE (OLD BUILDING). Q=SERPENTINE IN HYDE PARK.

tion with the district—there is a tradition that he lived near what is now Queen's Gate—is preserved in the name Cromwell Road. Knightsbridge and Brompton maintained their sequestered character until comparatively recent times. It is recorded that until the middle of the nineteenth century, which must be well within the memory of the oldest inhabitant, people

purchased for the modest sum of 150,000*l.* from the profits of the Exhibition, is dominated on the northern and higher side by the Albert Memorial in Kensington Gardens and by the Royal Albert Hall. Would it be possible to find, in the whole educational history of the country, an example of money spent to greater advantage for the promotion of science and art? Sites have been provided for a splendid group of educational and public buildings and in addition a considerable annual income is received which is devoted to scientific purposes. The Exhibition of 1851 justified the hopes of its founders. It was to be for the nineteenth century

<sup>1</sup> It is fitting that NATURE should take advantage of the method of obtaining "bird's-eye" views by means of aerial photography. Arrangements have been made for a short series of articles dealing with certain London areas of scientific interest illustrated by such photographs. The first of these, on South Kensington, is here printed. This will be followed by an article on Bloomsbury by the same contributor.

what the tournament had been in mediæval times—a challenge to every land, “not to the brightest dames and bravest lances as of yore,” but to its best produce and happiest device “for the promotion of universal happiness and brotherhood.” Happy days! Never perhaps was the spirit of the English people more buoyant, hopeful, confident. This was due in part to a growing appreciation of the benefits which science would confer on humanity.

The Albert Hall was designed to carry out the Prince Consort's expressed ideas as forming “a central point of union where men of science and art could meet, where the results of their labours could be communicated and discussed, and where deputies from affiliated societies could occasionally confer with the metropolitan authorities.” Public response to the appeal for the Prince Consort's memorial was less generous than was expected. The memorial in Kensington Gardens, which cost 130,000*l.* and took twenty years to complete, absorbed all the free-will offerings, including 50,000*l.* from Parliament, and it was therefore necessary to establish the Albert Hall on a commercial basis with the financial assistance of the 1851 Exhibition Commissioners, and even of the builders. A capital sum of 200,000*l.* was raised and seats were retailed (with a generous tenure of 99 years) for 100*l.* each. The foundation-stone was laid by Queen Victoria in 1867 and the Hall was opened in 1871. Those who, in view of the uses to which the Hall is occasionally put, may feel doubt as to the high ideals of its founders should read the inscription on the frieze, which asserts: “This Hall was erected for the advancement of the arts and sciences and for the works of industry of all nations, in fulfilment of the intentions of Albert, Prince Consort.”

Not far south from the Albert Hall is the most beautiful building on the estate, and possibly in the kingdom, the Imperial Institute. This magnificent pile is the permanent memorial of the completion of the first fifty years of Queen Victoria's beneficent reign. Initiated by the Prince of Wales with the co-operation of the Lord Mayor of London, contributions to the fund poured in from all parts of the Empire. By 1892 a capital sum of 413,000*l.* had been obtained, including 236,862*l.* in private donations from Great Britain and 101,550*l.* from India, and a public grant of 20,000*l.* from Canada. Queen Victoria laid the foundation-stone on July 4, 1887. On this occasion the Prince of Wales expressed the hope that the Institute would hereafter exhibit not only the material resources of the Empire, but be “an emblem of that Imperial unity of purpose and action which we believe has gathered strength and reality with every year of your Majesty's reign.” Mr. T. E. Collcutt was the architect, and the style is Italian Renaissance, with rich and abundant ornamentation. The central tower, 280 feet high, contains the Alexandra Peal of ten bells, given by an Australian lady.

Alas! the founders of the Imperial Institute gave more thought to raising the necessary capital than to sordid considerations of current income and expenditure. A somewhat fanciful scheme for electing Fellows, who were given certain club facilities and the right to use letters after their names, came to an untimely end. Call a building a white elephant

and close its doors may be accepted as a paraphrase of a well-known proverb. In serious financial difficulties, the Institute sought the protection and assistance of the Government, which adopted the familiar expedient of taking in lodgers. Thus it came about that the University of London, which during the whole course of its existence had flitted like an embarrassed shade from one set of Government lodgings to another, including Somerset House, Marlborough House, and Burlington Gardens, obtained possession in 1900 of the larger part of the Imperial Institute for administrative purposes. In the remaining part of the building, the Imperial Institute continues its work of investigation and propaganda. Let us hope that in the near future the University may find its Canaan in Bloomsbury and this monumental building may again be wholly used for the noble purposes, sealed and sanctified by the War, for which it was originally founded; thus may Queen Victoria's earnest prayer at its inauguration in 1893 be fulfilled that the Institute might “never cease to flourish as a lasting emblem of the unity and loyalty of the Empire.”

Reverting to the history of the Commissioners' estate, we find that at an early stage a large piece of ground, 12 acres in extent, was sold to the Government for the purposes of the Science and Art Department and its colleges and museums. This Department, originally founded in 1853 as a branch of the Board of Trade, became a few years later a distinct department of the Privy Council. It was moved westward from its quarters in Marlborough House in 1857 and drew up a programme of educational and scientific work which made “South Kensington” famous throughout the civilised world. The mere catalogue of the institutions which the Department administered is sufficiently impressive, including the South Kensington (now the Victoria and Albert) Museum, the Science Museum, the Science Library, the Royal College of Science, the Royal School of Mines, and the Royal College of Art. The Royal College of Science and Royal School of Mines claim descent from the Government “School of Mines and of Science applied to the Arts,” established in Jermyn Street in 1851, and from the Royal College of Chemistry, originally established in Oxford Street, which combined with the School of Mines in 1853. The various departments were transferred to South Kensington between 1872 and 1880 to the old building in Exhibition Road, an early and beautiful example of building in terra-cotta. In 1905 the new chemical and physical laboratories, designed by Sir Aston Webb, were opened in the Imperial Institute Road, and, at about the same time, the new Victoria and Albert Museum, built to the designs of the same architect. The work of the Science and Art Department as a separate department came to an end under the Board of Education Act of 1899. It must be admitted that its adventures into the domain of secondary education were less happily inspired, and that there was need for co-ordination between secondary and technical education. In its day and generation, however, the Department did a great work, from which the impartial historian of national education will not withhold grateful appreciation and the historian of the late War may trace some of the silver threads of victory.

South Kensington was not only closely associated with the early history of general scientific education, but it recapitulates that history. A permanent memorial there to the technical education movement of the 'seventies and 'eighties is the City and Guilds of London Institute for the Advancement of Technical Education. The Institute was formed in 1878 by the Livery Companies of the City of London, one of its principal objects being the establishment of the Central Technical College to supply higher technical education to productive industry. It was designed originally as the coping-stone of a system of technical schools, and particularly for the training of technical teachers. The foundation-stone of the College was laid by the Prince of Wales in 1881, and the building was completed three years later. Its work is now confined to engineering education, and it is one of the largest and best-equipped schools for this subject in the country.

The next important movement, which had for its object the development of teaching and research in applied science, culminated in 1907 in the establishment of the Imperial College of Science and Technology, to which a Royal Charter was granted. The Board of Education transferred to the new governing body of the Imperial College the control of the Royal College of Science and the Royal School of Mines; and the Central Technical College, renamed the City and Guilds (Engineering) College, was also brought into the scheme of common administration. Remarkable progress has since been made in developing the resources of the colleges for teaching and research. A new building has been erected for the Royal School

of Mines, and an extension (provided by the Goldsmiths' Company) of the City and Guilds College and others for botany, plant physiology and pathology, and chemical technology, while the social needs of the students have been met by the provision of a special building for the Imperial College Union.

The foregoing list by no means exhausts the buildings at South Kensington. The Natural History Museum (a branch of the British Museum) is in grey terra-cotta, built to the designs of Alfred Waterhouse, and was finished in 1880. It is both a museum and a centre for natural history study and research. The Royal College of Music, a less austere enterprise, was built by Sir Arthur Blomfield and opened in 1894; and the Royal School of Art Needlework and the headquarters of the Royal Geographical Society in Kensington Gore must also be mentioned.

Some final reflections. First and most obvious, the available space at South Kensington is now practically exhausted. Almost the only science which has not been practised at South Kensington is town planning, and there can be no doubt that the area might have been planned more economically. Much still remains to be done in providing new departments of pure and applied science. Under no possible re-organisation of higher education in the metropolis can South Kensington cease to be a most important centre for education and research in science and art. It has great resources in traditions, in men, in materials; and if, like Oxford, it is already the home of some lost causes, it has a marvellous power of adapting itself to new conditions.

## Dark Nebulae<sup>1</sup>

By Prof. H. N. RUSSELL, Mount Wilson Observatory.

IT is now generally believed that many of the dark markings in the Milky Way, and dark starless regions in the sky, are produced by the interposition of huge obscuring clouds between us and the more remote stars. A long list of such dark markings has been given by Barnard,<sup>2</sup> who has done more than anyone else to point out their importance and probable nature. In some cases, as in the Pleiades, Orion, and Ophiuchus, these "regions of obscurity" merge into faintly luminous nebulosity in the vicinity of certain stars, in such a way that there can be no doubt that they lie near these stars in space.

It thus appears that the obscuring masses or dark nebulae in Ophiuchus and Scorpius are at a distance of 100 to 150 parsecs, those in Taurus at probably about the same distance, and those in Orion some 200 parsecs from us, while the dimensions of the individual clouds are themselves measured in parsecs.

The occurrence of these three great regions of obscurity within a distance which is so small compared with that of the galactic clouds indicates that such objects are probably of great cosmical temperature.

These dark nebulae usually appear to be quite opaque. In some cases the stars can be seen faintly through

them, apparently without much change in colour; but in some examples<sup>3</sup> stars imbedded in dense luminous nebulosity are abnormally red.

Of the various forms in which matter may be distributed in space, by far the most efficient in producing obscuration is fine dust, since this has the greatest superficial area per unit of mass. In a cloud composed of spherical particles of radius  $r$  and density  $\rho$ , distributed at random so that the average quantity of matter per unit volume is  $d$ , the extinction of a beam of light in passing through this cloud will be  $e$  stellar magnitudes per unit of distance, where  $e = 0.814 \frac{qd}{\rho r}$ . The numerical factor is independent of the physical units which are employed. The factor  $q$  is introduced to take account of the complications which occur when the size of the particle becomes comparable with the wave-lengths of light.<sup>4</sup> For particles more than two or three wave-lengths in diameter  $q$  is sensibly equal to unity. For smaller particles it increases and is a maximum, 2.56, when the circumference of the particle is 1.12 times the wave-length. It then rapidly diminishes and becomes nearly equal to  $1/3 \times (2\pi r/\lambda)$  for particles of less than half this diameter.<sup>5</sup> The ratio

<sup>1</sup> Seares, F. H., and Hubble, E. P., *ibid.*, 52, 1920 (8-22); *Mt. Wilson Contr.*, No. 187.

<sup>2</sup> Schwarzschild, K., "Sitzungsberichte der K. B. Akad. der Wiss.," *Math.-Phys. Kl.*, München, 31, 1901 (293-338); Proudman, *Monthly Not.*, R.A.S., London, 73, 1913 (535-539).

<sup>3</sup> Barnard, E. E., *Astrophys. Journ.*, Chicago, 38, 1913 (496-501).

<sup>1</sup> Communication to the National Academy of Sciences, Washington, on March 14. Reprinted from the Proceedings of the Academy, vol. 8, No. 5, May 1922.

<sup>2</sup> Barnard, E. E., *Astrophys. Journ.*, Chicago, 49, 1919 (1-23).

$q/r$  is a maximum, 2.42, when the circumference equals the wave-length.

For clouds of the same mean density  $d$  the opacity reaches a sharp maximum when the particles are of this size. At the same time the absorption changes from the non-selective type to the selective type, varying as  $\lambda^{-4}$ . For visible light the maximum opacity occurs when the radius is  $0.086\rho$ . A cloud of particles of this size, and of the density of rock (2.7), will exert an absorption of one magnitude if it contains only  $1/86$  of a milligram of matter per square centimetre of cross-section, regardless of its thickness. If the particles are of half this size, or smaller, the selective absorption is almost as complete as for a gas, but may be nearly 100 million times as great.

Obscuration of light in space, therefore, whether general or selective with respect to wave-length, will be produced mainly by dust particles a few millionths of an inch in diameter, unless such particles form a negligible proportion by weight of the obscuring cloud.

It is just these particles, however, which will be most influenced by the pressure of the radiation of the stars. Calculations from more accurate data confirm Schwarzschild's conclusion that for a particle of the optimum size and the density of water, the repulsive force of the sun's radiation is about ten times the gravitational attraction, and also show that for stars of the same brightness, but other spectral types, the radiation pressure will be about two-thirds as great for Class M and increase for the whiter stars, till for Class B it is fully ten times as great as for solar stars.

Dwarf stars will scarcely repel dust at all, but giant stars, and especially the very luminous one of Class B, will repel it very powerfully. Only the coarser particles can come near such a star—the finer ones being driven away. This selective removal, from the vicinity of bright stars, of the particles which are most efficient in cloud formation, may explain the fact that the luminous portions of these dark nebulae, though centred upon stars, do not brighten up in their immediate neighbourhood so much as might have been anticipated.

The finest dust must continue to be repelled by the stars, whatever their distance. It may congregate to some degree in interstellar regions, where the repulsive forces from stars on opposite sides are nearly equal, but it can be in no true equilibrium there, and must escape ultimately to an indefinitely great distance.

Some force, however, operates to hold these dark clouds together, for their outlines are often sharp. This is probably the gravitational attraction of the cloud itself.

Taking a spherical cloud as an example we find that, if its mass is  $M$  times that of the sun, and its radius  $R$  parsecs, the velocity of escape at the surface is  $0.092 M^{\frac{1}{2}} R^{-\frac{1}{2}}$  km./sec. The internal velocity of the nebular material is known only in the case of the Orion nebula, where the luminous gas shows irregular variations in radial velocity from point to point, amounting to about 5 km./sec. on each side of the mean.<sup>6</sup>

For a nebula 1 parsec in diameter (which may be taken as a rough representation of the small black, almost round spot about  $15'$  in diameter, discovered

by Barnard<sup>7</sup> in Ophiuchus) the mass must be 60 times that of the sun, if the escape velocity is to be 1 km./sec.

If all this matter were in the form of particles of rock of the optimum size, the extinction for light passing centrally through the cloud would be 2000 magnitudes. An extinction of 10 magnitudes (quite sufficient for opacity) would be produced if the radii of the particles were  $72 \mu$ .

Though these numerical values are largely conjectural, it appears probable that the aggregate mass contained in one of these great obscuring clouds must be very considerable—probably sufficient to form hundreds of stars—and that a sensible fraction of the whole mass must be in the form of dust less than  $0.1$  mm. in diameter.

It can easily be shown that any dust cloud which is impervious to light must also be impervious to particles such as those of which it is composed (and to free-moving electrons as well) in the sense that such a particle could not traverse the cloud without a practical certainty of collision. These collisions may account for the existence of dust within the clouds, even if it was not a primitive constituent.

The transition from these dark nebulae to luminous nebulae in the vicinity of the stars appears to occur in two ways. The first is by simple reflection of the light of the stars: this appears to occur in the nebulosity surrounding the Pleiades, the star  $\rho$  Ophiuchi, and probably in many other cases. The second is by the excitation of gaseous emission, as in the Great Nebula of Orion, which is connected with one of the greatest known regions of obscuration and itself shows signs that obscuring masses lie in front of it.

Both theoretical considerations, as suggested by the writer<sup>7</sup> and the facts of observation collected by Hubble,<sup>8</sup> indicate that the luminosity of gaseous nebulae is probably due to excitation of the individual atoms by radiations of some sort (aethereal or corpuscular) emanating from neighbouring stars of very high temperature. In the Orion nebula the stars of the Trapezium ( $\theta$  Orionis) appear to be the source of excitation.

There is no reason to believe that the luminous gas forms the whole, or even any large part, of the matter present within the region—only that it is selectively sensitive to the incident excitation, and therefore gives out most of the light, just as the gases (carbon compounds and nitrogen) do in the coma and tail of a comet.

If the turbulent motions of the various parts of this nebula are of the same order of magnitude in the other two co-ordinates as in the radial direction, they must correspond to an average proper motion of 1.5 astronomical units per year, or about  $0''.8$  per century (with Kapteyn's parallax of  $0''.0055$ ). In a million years this would carry a nebulous wisp through  $2^\circ$ , which is more than the whole extent of the nebula.

It appears probable, therefore, that the aspect of the Orion nebula was entirely different a million years ago from what it is now, as regards its details. There is no reason, however, to suppose that the nebula was not there. We may rather imagine that wisps and clouds of dust, carrying gas with them, are slowly drifting about. Some of them pass through the field of excita-

<sup>7</sup> Russell, H. N., *The Observatory*, London, 44, 1921 (72).

<sup>8</sup> Hubble, E. P., "Annual Report of the Mount Wilson Observatory," 1921; "Year Book of the Carnegie Institution of Washington," 1921.

<sup>6</sup> "Publications of the Lick Observatory, Berkeley, Cal.," 13, 1918 (98).

tion due to the radiations from the Trapezium stars, and, when in this field, the gas is set shining—faintly near its outskirts, and without excitation of the nebular lines; more strongly, and with the nebular lines, near the middle.

According to unpublished investigations by Hubble, it appears probable that the absorbing clouds in Orion, not far from the nebula, weaken the light of stars

behind them by at least ten magnitudes. The exciting radiations probably penetrate to a relatively small depth into the mass and, even if they went deeper, little of the excited light could get out again. The Orion nebula, on this hypothesis, may be regarded almost as a superficial fluorescence of the gaseous portion of this vast dark cloud, in the limited region where it is stimulated by the influence of the exciting stars.

### The Corrosion of Ferrous Metals.

THE fact that iron readily perishes when exposed to the forces of Nature must have been observed by man practically as long as the metal itself has been recognised. But it is only comparatively recently that the problem of the preservation of iron from corrosion has developed into one of such stupendous economic importance as at the present day. Sir Robert Hadfield estimates the wastage of the world's steel on account of rust alone to reach some 29 million tons for the year 1920. This, at an average figure of 20*l.* per ton, represents a loss to the community of at least 580,000,000*l.* One interesting feature of this calculation is that the annual increase in the world's total stock of iron and steel is only some 30 per cent. of the annual production, the remaining 70 per cent. being absorbed in replacing wastage consequent upon fair wear and tear and upon corrosion.

In a paper read before the North-East Coast Institution of Engineers and Shipbuilders in April last, Mr. A. Pickworth most opportunely directs the attention of marine engineers to this aspect of the subject. It is pointed out that the repairs necessary to counteract the ravages of rusting during ten years' service in the case of a single battleship have, for structural work alone, been known to cost some 150,000*l.* Any one, therefore, who can assist in combating this destructive plague to iron and steel merits the gratitude of the community.

It is now well recognised that, in addition to air, the presence of liquid water is essential to corrosion. Rise of temperature accentuates the evil, the rate of oxidation of iron immersed in water at 80° C. being more than seven times as great as that at 0° C. It is easy, therefore, to offer an explanation, as Mr. Pickworth points out, for the fact that corrosion assumes more serious proportions in the vicinity of boiler-room tanks on steamers than elsewhere. The tanks, whether used for ballast or feedwaters, are alternately filled and more or less completely emptied, but are rarely, if ever, thoroughly dry, for obvious reasons. The residual moisture, coupled with unequal distribution of waste heat from the boilers, and erratic cooling from the floor and shell plating in contact with the sea under the vessel, results in rapid corrosion. The steel work of the bunkers of a vessel frequently requires patching or renewing on account of corrosion. This is particularly the case with pocket bunkers at the sides of the boilers or 'tween-deck bunkers above the boilers. Not only does the heat from the boilers and the moisture in the coal tend to produce a corrosive atmosphere, but the abrasive action of the coal as it enters from the shoots and while it is settling as the lower layers are worked out all tend to accentuate the destruction of the metal. In practice it is found that the lower parts of the bunkers

are the most seriously affected, and this is attributed to the accumulation of a mixture of small coal and mud which is rarely removed except at special surveys. Although in exceptional cases the outside surfaces of the shell plating of a ship may be seriously pitted and corroded, as, for example, when the vessel has been lying in very foul waters, the general rule appears to be for the wastage to be greater on the inside surfaces. This is due, in the main, to the extra cleaning and general attention received by the outside surfaces. Special care should be paid to those portions of the inside shell immediately under the sidelights, for the constant trickling of rain or water of condensation from the glass induces most serious corrosion, resulting at times in actual perforation of the plating.

As might be expected, the most serious external corrosion of the shell plating occurs in the neighbourhood of the wind and water line, the metal being alternately drenched and exposed to air. The surface water also is in motion relatively to the plates, and this tends to stimulate corrosion. One interesting point deserving of consideration is the fact that the external portions of a vessel above the water-line receive deposits of sodium chloride in consequence of the evaporation of sea spray. Owing to the hygroscopic character of the deposit, as well as to its chemical activity, corrosion is readily induced thereby.

It is difficult to obtain trustworthy comparative data on the relative efficiencies of different methods of avoiding corrosion. Early man frequently surrounded his iron with copper or bronze, so that his implements might possess the strength of the former combined with the incorrodibility of the latter metal. Modern developments of this process are galvanising, tinning, electroplating, and the like. The Bower-Barff process consists in coating the iron or steel with magnetic oxide, which is an excellent protection so long as it remains unbroken. The metal is cleaned, heated in a closed chamber by means of producer gas, and finally oxidised in a current of superheated steam for a couple of hours. If, however, the resulting coat of oxide should crack or chip off at any point, the layer of unprotected metal thereby exposed is rapidly attacked. The oxide functions as cathode and the metal as anode, so that deep pitting ensues. Mr. Pickworth mentions that a certain shipowner, relying on the protective action of mill scale, gave instructions for a ship to be built, the shell plates of which were to retain their mill scale as completely as possible. For a time all went well on service, but suddenly the vessel developed leaks and was almost lost. Upon docking it was found that many of the plates had been deeply pitted and even perforated in a number of places where the mill scale had been destroyed either during construction or through

abrasion in service. It is now usual to remove scale by pickling, by weathering, or by some other suitable method, prior to painting, in order to avoid such disaster.

A second method of combating corrosion consists in alloying the iron with some other element that will render it incorrodible. This is the principle underlying the so-called "stainless steel," which contains some 12 to 14 per cent. of chromium, and is remarkably resistant to neutral corrosion, although acids dissolve it with ease. Unfortunately the cost is high, but once that difficulty is surmounted, a vast future lies in store for stainless metals. To realise this it is not essential that the price should fall to that of an ordinary carbon steel. To the writer's own knowledge the cost of painting the steel work in a certain large works recently averaged nearly 5*l.* per ton of steel painted. Assuming the paint will not require renewal within five years, the average annual cost is still 1*l.* per ton of steel. A firm could thus clearly afford to pay considerably extra in initial outlay if by so doing a really incorrodible structure could be obtained which would not require subsequent periodic treatment.

Yet a third method of reducing wastage by corrosion has been investigated, namely, the removal of the active corroding agent, dissolved oxygen, from waters in contact with the metal. The various means of doing this are discussed by Mr. Frank N. Speller<sup>1</sup> in an interesting paper entitled "Control of Corrosion by Deactivation of Water." The method has its limitations, but for hot-water heating systems it would appear to be particularly suitable. The oxygen may be removed either chemically or by purely physical means. A

<sup>1</sup> Journ. Franklin Institute, April 1922.

satisfactory plant was erected in Pittsburgh in 1915 in which the water is first made to flow through a "de-activator" which is a tank filled with a special type of expanded steel lathing. The steel rusts and thus deoxygenates the water, which then passes on to the heating system and is now non-corrosive. The principle is simple enough, but in practice it is necessary to pay great attention to the manner in which the deactivator is charged. Miscellaneous steel turnings usually rust together into a tight mass which offers serious resistance to the flow of the water. In a later form of deactivator installed in Boston in 1917 a filter was provided in order to remove all suspended hydroxide of iron.

Many types of mechanical de-aerators have been designed. The apparatus made by "Balke" in Germany appears to have given satisfactory results. The water at ordinary temperature is sprayed into a chamber carrying a 90 per cent. vacuum, and the released gases are pumped off into a condenser. The efficiency of mechanical de-aerators is of course limited by the solubility of the gases, the temperature, and the power of the vacuum. Normally, therefore, there will always remain a certain amount of unextracted oxygen which may be sufficient to induce gradually serious corrosion in the plant. On the other hand, chemical processes can remove all the dissolved oxygen under favourable conditions. Speller therefore suggests that where very large volumes of water require de-aeration, an economical type of apparatus would be one in which the bulk of the dissolved oxygen is first removed by some simple form of mechanical de-aerator, and the residual oxygen, say the last 5-10 per cent., by chemical treatment.

J. N. F.

## Obituary.

ERNEST SOLVAY.

ON May 26 last, at the ripe age of eighty-five, there passed away, at his residence in Brussels, in the person of Ernest Solvay, one of the world's greatest industrial chemists. To Nicolas Leblanc belongs the credit of inventing the first successful process for manufacturing artificial soda; but it remained for the brothers Ernest and Alfred Solvay to provide the world with a pure and cheap product.

Ernest Solvay was born at Rebecq in Brabant, Belgium, on April 16, 1838. He was the son of Alexandre Solvay, a quarry proprietor and salt refiner. In 1838 two English chemists, Harrison Gray Dyar and John Hemming, patented a process for producing carbonate of soda by acting upon sodium chloride with ammonium bicarbonate and producing sodium bicarbonate and ammonium chloride. The sodium bicarbonate upon calcination yielded soda ash, and the ammonium chloride was decomposed by lime to free the ammonia for re-use. The patentees themselves, and several well-known chemists, erected works to manufacture by this process, but all proved failures, principally on account of the high loss of ammonia. The young Belgian chemist, Ernest Solvay, at the age of twenty-four, was attracted by the process, and, after two years of study and experiment, he devised such

modifications as appeared to him to ensure its practicability, and embodied them in a patent in 1863.

Calling to his aid his brother Alfred, who had been trained for a commercial career at Antwerp and at Hull, they erected works at Couillet, near Brussels, as Solvay et Cie, with a capital of 540*l.* With the starting of these works in 1865 the brothers met with most of the troubles and disasters that had daunted the earlier experimenters. Their experience is perhaps best described in Ernest Solvay's own words:

"With the starting of the works in 1865 began the everlasting struggle, the incessant need for improvements in apparatus, and the series of accidents inseparable from every new industry. This was the hill of Calvary which we had to climb, and its rough road might perhaps have stopped me if I had not been sustained by my confidence of success in the task that had to be accomplished, and above all by that devoted helper, my brother Alfred."

In the following year (1866) the works were producing only 1½ tons of soda ash per day, but by 1869 the process had proved so successful that the works were doubled in size. During these fateful four years, Solvay had encountered all the difficulties that had baffled his predecessors, both technical and financial; but, by his application of wonderful scientific skill and his tireless attention to work, he succeeded in evolving



a remunerative process of manufacture. It was, however, far from perfect, and for the next fifty years Solvay ever strove to reach perfection, sparing neither time nor money to make it approach the ideal. At the time of his death, there are very few methods of manufacture that have so nearly reached the ideal as the Ammonia Soda process.

In 1873 Solvay granted a licence to John Brunner and Ludwig Mond to work the process in England, and Brunner, Mond and Co. started works at Winnington, Northwich, in that year. From this business connexion there sprang up a friendship among the three men that lasted as long as their lives, and it is difficult to decide whether Solvay or Mond effected thereafter the greater number of improvements in the process and apparatus.

In the same year Solvay and Co. erected their large works at Dombasle near Nancy, introducing all such improvements in plant as experience at Couillet had shown to be advisable.

From this time onwards to 1914 few years passed without some new works being erected to carry on the manufacture; in the United States in 1881, in Russia in 1881, in Germany and Austria in 1885, and later in Hungary, Spain, Italy, and Canada, until in 1914 there were scattered throughout the world twenty-three separate works engaged in the Solvay Ammonia Soda process, which were capable of producing nearly 2,000,000 tons of soda ash per year.

With the growth of the Ammonia Soda process, the production of alkali by the Leblanc method gradually declined, until it reached the point where it had to depend upon its chlorine products for its continued survival, and of late years even this monopoly has been seriously challenged by the electrolytic processes. In 1863 the world's production of soda, by the Leblanc process, was 300,000 tons a year. In 1913, the total production amounted to nearly 3,000,000 tons, of which almost two-thirds was made by the Solvay process, while the sale price had dropped to one-quarter. The essential raw materials for the Solvay process are salt, limestone, coke, coal, and ammonia, and in selecting sites for new works, Solvay was ever careful to choose them as near as possible to the source of supply of some of these.

In seeking for a cheap and plentiful supply of ammonia, Solvay was led to study the production of coke, and eventually, in conjunction with Mr. Semet-Solvay, he designed a bye-product coke oven which yielded ammonia through the scrubbing of the gas before its combustion for heating purposes. Many thousands of these Semet-Solvay ovens have been built in Belgium, France, England, Germany, the United States, Italy, and Japan, and in 1913 they were producing about 10 million tons of coke a year.

In the midst of his immense industrial activities Solvay was ever mindful of the welfare of his employees. Working a process that must of necessity be continuous, he was one of the first to reduce the hours of labour from 12 to 8-hour shifts. He insured his workmen against accidents, instituted savings-banks and retiring allowances, provided them with medical attention, built houses for them, and remitted the rent in cases of long service or distress, made free grants of land for culture, built schools and gave scholarships, and made

grants in aid of higher education both in Belgium and abroad.

On the occasion of the company's fiftieth anniversary, a number of grants were made, among which were: 200,000 francs to the Université du Travail, Charleroi, 500,000 francs to provide prizes every fourth year for work on such contagious diseases as the poor are specially liable to suffer from, 500,000 francs to the University of Paris towards the Institute of Applied Chemistry, 500,000 francs to the University of Nancy to complete the Electrical Institute and found a chair of electro-chemistry. In addition, their workpeople received substantial concessions and bonuses. Ernest Solvay's sympathies and interests were not confined to his own workpeople, for he was absorbingly interested in the intellectual and social advancement of mankind in general. He published not only many treatises on these subjects, but also from his immense wealth financed or created numerous institutions for their study; e.g. the Solvay Society of Brussels and institutes of chemistry, physics, physiology, and sociology. In order to encourage the development of chemical and physical science, by providing funds for research workers and by holding conferences, he also inaugurated the Solvay International Institutes of Chemistry and of Physics, and endowed each with a capital of 1,000,000 francs.

During the war, Solvay elected to remain in Brussels in order that he might alleviate the suffering which he foresaw would be the lot of the poor. He devoted his energies and his fortune to this object throughout the whole of the German occupation, and the city will never forget his beneficence. Upon his return to the capital, King Albert personally expressed his thanks to him and created him a Minister of State. He was also the recipient of many other honours. He was a Grand Commander of the Order of Leopold, a Chevalier of the Legion of Honour, a Doctor of the University of Brussels, an honorary member of the Royal Institution of London, and of the German, French, American, and Dutch Chemical Societies, and a corresponding member of the French Academy of Sciences.

At the celebration of the fiftieth anniversary of the formation of his company, he was presented by Prof. Haller in the name of the French Institute with the gold Lavoisier Medal, and by Prof. Appell with the medal of the University of Paris.

In private life Ernest Solvay's tastes were simple, and he was ever happiest in his own family circle. He attracted to his side many men of exceptional ability and formed lasting friendships. By nature he was generally optimistic, and he had a very keen sense of humour. He was an ardent mountaineer, and regularly his summer holidays were spent among the Alps. He could climb vigorously at the age of seventy-five, and abandoned the sport only a few years prior to his death.

JOHN I. WATTS.

#### THE HON. V. A. H. H. ONSLOW.

HUIA ONSLOW, son of the fourth Earl of Onslow, was born in New Zealand in 1890, where his father was Governor-General. Educated at Eton and Trinity College, Cambridge, he met with a calamitous accident at the close of his University career: an injury received in diving left him paralysed below the waist, with no

hope of recovery. Though broken in body, his courage never left him, and with splendid bravery he devoted to scientific work such as remained to him of life. Special facilities for research led him to settle in Cambridge, where he turned one of the rooms of his house into a laboratory into which his couch could be wheeled. Here he became a pioneer in establishing contact between the two growing branches of biology—biochemistry and genetics. Genetical research had recently demonstrated the existence of two distinct kinds of white in the coat of certain animals—one dominant and the other recessive to colour. It had been surmised that in the former case the coat carried something which inhibited the production of colour, and that in the latter either the chromogen was absent, or else some substance which activated it. Onslow's chemical work took the question out of the realm of speculation, and placed it on a solid ground of fact—a notable contribution, which will be found in the Proc. Roy. Soc., 1915. At the same time he was carrying out extensive breeding-experiments with mice and rabbits, both at Cambridge and Pyrford, which helped materially in laying the foundation of a sound genetical knowledge of coat-colour. But it was the biochemical side that attracted him most, for he realised that the geneticist could not go very deep without the help of the chemist. He wished to approach the problem from both sides, and, with this end in view, started breeding-experiments with moths, concerning himself chiefly with melanic forms as likely to be of service for the chemical side of the inquiry. The results were published in a series of papers on the "Inheritance of Wing Colour in Lepidoptera," which appeared in the *Journal of Genetics*, 1919-21. Meanwhile, he became interested in the brilliant iridescent colours exhibited by many insects, and on this subject contributed last year an important paper to the *Philosophical Transactions*. Full of fresh and suggestive observations, it is pervaded by a critical power of thinking, and a knowledge of the physics involved, which must make it a landmark for future investigators of an intricate and fascinating series of problems.

And all this from an invalid couch, full of suffering, and stricken beyond hope of recovery. But fine as is the achievement, finer still was the way in which it was won. With life seemingly wrecked at the very start, his spirit rose above the physical crash, bravely accepted what had to be, and created out of the ruins a fresh life which was the wonder of those who knew him. What he did, and what he was, will assure him of that immortality that lives upon the lips of men; and with that we may

"Leave him still loftier than the world suspects,  
Living and dying."

DR. A. R. WILLIS.

MANY students will regret the death of Dr. Ambrose Robinson Willis, at the age of seventy-two, on May 23 last. From 1872, when he entered the Royal School of Mines as a Royal Exhibitioner, until 1911, when he retired owing to ill-health from the Imperial College of Science and Technology, he had been continuously associated with the South Kensington institution.

In 1875 he obtained the A.R.S.M. in mining, metallurgy, and geology, the Duke of Cornwall's scholarship, the Murchison medal and prize, and the Edward Forbes medal and prize. The wide range of his studies is indicated by the facts that in 1876 he obtained first-class honours in zoology and chemistry at the London B.Sc.; in 1879, the London B.A.; in 1881 the M.A., and in 1883 the D.Sc. in mathematical physics. He was made assistant-professor in mathematics and mechanics at the Royal College of Science in 1884, being associated first with Goodeve and later with Perry. He also acted as examiner in mathematics for the Universities of London and Manchester.

It was as an instructor that Dr. Willis will be remembered, not only by old students of South Kensington, but by an enormously wider circle, in his capacity as an examiner in mathematics to the Science and Art Department and afterwards to the Board of Education. With his fellow-examiners Twisden and Wrigley, he exercised a tremendous influence for many years on students of mathematics and mechanics in all parts of the country. It was no small task virtually to direct the studies of an army of men, the majority with little time to spare from manual work, without means and often without a teacher, and whose only inspiration and incentive came from the desire to pass the various Board of Education examinations. That the duty was ably and wisely carried out will be readily admitted, and by none more than by those who, entering the Royal College of Science as exhibitors or scholars, came into personal contact with the man who had done so much to direct their earlier studies.

Times have changed, and it is not so easy now to bring home the realisation of what it meant to men whose training had been on these lines, to attend Dr. Willis's lectures and listen to his extraordinarily clear, orderly, and inspiring exposition of mathematics. In his prime few can have equalled him in this respect—he radiated enthusiasm as he developed the argument, and his triumph as the full power of the attack made itself felt was delightful to see. Many hundreds of science teachers will still remember wistfully Dr. Willis's carefully prepared lectures in the short "summer courses" for teachers, which were arranged each year at South Kensington by the Board of Education.

Dr. Willis took a real personal interest in his students and possessed the faculty of making the shyest of men feel quite at ease with him. Many of his students can testify to innumerable kindnesses unobtrusively performed, and to his quiet support of any movement which would activate the social side of the College's work. His whole-hearted thoroughness, wide experience, geniality, North-country shrewdness, and sound common sense were greatly appreciated in university circles. His retirement in 1911 was made the occasion of a demonstration of affection and good-will from hundreds of old students, and he then voiced the great satisfaction that he felt to see so many of his old students playing prominent parts in the scientific world, not least in the development of aeronautics.

A. R. R.  
G. W. C. K.

## Current Topics and Events.

THE portrait medallion of Sir Norman Lockyer, by Sir Hamo Thornycroft, which is to be erected at the Norman Lockyer Observatory, Salcombe Hill, Sidmouth, will be unveiled by Sir Frank Dyson, Astronomer Royal, on Saturday, July 22. Lt.-Col. F. K. McClean, a generous benefactor to the observatory, will present the medallion on behalf of the subscribers, and it will be received by Sir Richard Gregory, chairman of the council. The observatory was erected in 1912 upon a plateau 550 feet above sea level, and is unique of its kin in Great Britain, being vested in a registered corporation which possesses the whole of the property and controls the operations. It was founded by Sir Norman Lockyer, and was formerly called the Hill Observatory, but since that distinguished astronomer's death the name has been changed to the Norman Lockyer Observatory in honour to his memory. The director is Major W. J. S. Lockyer, and there is a research committee consisting of Sir Frank Dyson, Prof. A. S. Eddington, Prof. A. Fowler and Prof. H. H. Turner. The observatory possesses an equipment of the first rank for spectroscopic work, and photographs of stellar spectra taken in it are being used for the determination of the parallaxes of stars. The method used was first worked out at the Mount Wilson Observatory and it represents one of the most remarkable developments of astrophysics ever achieved. The gifts of Sir Norman and Lady Lockyer, Lt.-Col. McClean, Mr. Robert Mond, Capt. W. N. McClean and others, together with subscriptions of members, have been sufficient to establish and maintain the observatory hitherto, but additional funds will be required if the work is to be carried on efficiently. In the United States, generous donors to astronomy seem to be forthcoming whenever they are needed, with the result that the chief advances of astronomical science are being made there. The Norman Lockyer Observatory, on account of the elasticity of its constitution, offers similar benefactors in this country an excellent opportunity for emulating the example afforded by America, and we trust that one or more of them will provide the means to continue and extend the work to which a few devoted people have already contributed their full share.

UNUSUALLY heavy gales for the season of the year have occurred over England during the early part of July, especially during the night of July 5-6, and the tempestuous winds were accompanied by torrential rains. On the south-east coast of England the wind attained the velocity of about 60 miles an hour, and at Kew Observatory the velocity registered 53 miles an hour. London experienced considerable interruption to telephone communication, and in the open country much damage was done to the fruit crops. A renewal of the stormy conditions occurred on July 8-9.

OWING to the early breaking of the monsoon the attempt on Mount Everest planned for June 3 had to be abandoned. The *Times* announces that the

members of the expedition are now returning to India. Col. Strutt, Dr. Longstaff, and Mr. Finch have already sailed for England. Mount Everest thus remains unconquered, at any rate for the present, the greatest altitude that was reached being 27,300 feet, or about 1700 feet below the summit. Col. Strutt believes that given favourable weather a future expedition should be able to reach the summit.

THE *Quest* with the Shackleton-Rowett expedition has left Cape Town and arrived at Simonstown on July 7. After a few days there, according to the *Times*, she sails for home via South Trinidad and Rio de Janeiro. It is proposed to spend two days at South Trinidad, the uninhabited volcanic island in the South Atlantic. The island has been frequently visited, notably by the *Discovery* in 1901 and the *Valhalla* in 1905. At an earlier date it obtained fame by reason of several searches for buried treasure. The *Quest* may be expected at Plymouth about September 21.

ACCORDING to the *Meteorological Magazine* of June, a new record height of 10,518 metres (34,500 feet) was attained by J. A. McCready in an aeroplane flight at Dayton on a Lepère machine, with a 400-h.p. Liberty engine, during September 1921. The previous record, by Major Schroeder, has been reduced by the authorities responsible for the official figures from 36,000 feet to 33,114 feet.

It is reported in the *Times* that Captain Amundsen, aboard the *Maud*, left Nome, Alaska, for Cape Barrow, on June 30. Early in August he proposes to make his flight across the Pole, either to Greenland or, more likely, to Spitsbergen. The route to Spitsbergen is the longer of the two, but Capt. Amundsen believes he can make the journey in eighteen hours. His aeroplane has been tested in a thirty-two hours flight. The Norwegian Government is taking steps to afford all possible assistance to Capt Amundsen in the event of his reaching Spitsbergen or Bear Island.

INVITATIONS to serve on the Committee on Intellectual Co-operation of the League of Nations have been accepted by Mr. D. N. Banerji, Prof. Henri Bergson, Mlle. Bonnevie, Prof. A. de Castro, Mme. Curie, M. J. Destrée, Prof. A. Einstein, Prof. G. Gilbert Murray, M. G. de Reynold, Prof. F. Ruffini, M. L. de Torres Quevedo, and Dr. G. E. Hale. The committee, which will be entrusted with the examination of international questions regarding intellectual co-operation, will hold its first meeting in Geneva on August 1.

SINCE the eruption of 1906, Vesuvius has remained inactive on the whole until the early part of the present year. On February 26 the main cone, which had grown since 1906 to a height of about 230 feet, collapsed during an eruption, and shortly afterwards lava issued from several fissures; it has flowed ever since in amounts that are considerable, though not sufficient for it to escape from the crater. Since February, a new crater has been formed and has grown with great rapidity. Towards the end of June,

a large fissure appeared in its western side, and from it there came a stream of lava about thirty feet wide. Owing to these recent flows and to the presence of sulphur fumes, it is difficult to reach the floor of the crater. In the *Times* for July 3 are reproduced, however, two photographs taken from within the crater, one of the new cone, and the other of the lava-stream issuing from it and showing very clearly the fluxion-structure of the lava.

MAY and June were both comparatively dry months this year at Greenwich Observatory, the rainfall in May being only 57 per cent. of the 100 year average, while June was 70 per cent. of the 100 year average for the corresponding month. In January, February, and April the rainfall was in excess of the average. In 1921, each of the first six months had a rainfall less than the normal. The total for the first half of the present year is 10.73 in., while in 1921 the total for the same period was only 5.97 in. The 100 year average for the six months is 10.47 in., and for the 35 year average, used by the Meteorological Office, 10.21 in., so that the period from January to June shows an excess on the normal. There was an absolute drought this year from May 26 to June 12, a period of 18 days, the only drought as yet registered in 1922. July bids fair to be a wet month; practically the average rainfall for the month in London fell in the first week.

THE Natural History Museum Staff Association held their summer scientific reunion in the board room of the Museum on July 5. There was a large attendance. Among other interesting exhibits were the following: specimen of the supposed gigantic Gastropod (*Dinocochlea ingens*) from the freshwater sandstones in the Wadhurst Clay, Hastings; the natural cast of a footprint of an Iguanodon from the Wealden Beds, between Bexhill and St. Leonards; opalised Mollusca of Cretaceous age from New South Wales and South Australia; skin with scutes of a stegosaurian dinosaur from the Upper Cretaceous, Alberta, Canada; specimens from the collection of Swiss minerals bequeathed to the Museum by the late Rev. J. M. Gordon; one of the four meteoric stones which fell in the Strathmore district of Perthshire and Forfarshire on December 3, 1917; living specimens of a branchiopod crustacean (*Leptesheria dahalacensis*) hatched from eggs contained in dried mud from Bagdad; ammonites with the operculum preserved and associated fossils from the same bed in the Lias at Charmouth, Dorset; Horse Chestnut seedlings, illustrating three different methods of replacing the bud of the primary shoot; a very rare British orchid (*Orchis hircina*) recently found near Lewes; examples of the remarkably different, smooth and partly rough, skinned fruits borne on the same tree of the Khatta orange, North India; model of Commerson's dolphin (*Cephalorhynchus Commersoni*) from Port Stanley, Falkland Islands; and the model, enlarged 7.40 diameters, of the itch mite (*Sarcoptes Scabiei*) recently made for the Museum by Miss Grace Edwards. Messrs. R. and J. Beck exhibited their most recent forms of microscope, and Duroglass Ltd. showed

examples of their glass-ware for preserving specimens in spirit and for use in chemical analysis.

At a meeting of the Royal Society of Edinburgh on June 5, Dr. C. G. Knott, general secretary, gave an account of a correspondence between the Academy of Sciences of Paris and the Royal Society of Edinburgh, in which the Council of the latter Society directed attention to the fact that the "Cable Guide" system which was being accepted as the invention of M. Loth during the late war, was invented by Mr. C. A. Stevenson thirty years ago, and described in the Proceedings of the Royal Society of Edinburgh in 1893. In 1921 M. Loth was awarded an important prize for his valuable work in connexion with naval problems, and the report of Vice-Admiral Fournier, in recommending the award, referred pointedly to the method of the pilot cable for guiding ships by electrical signals into harbours during night or at times of fog. A comparison of this report with Mr. C. A. Stevenson's patent of 1893 showed that the two systems were fundamentally identical. Compared with M. Loth's beautiful devices, made possible in these days by the remarkable developments in methods for detecting electric and magnetic charges, Mr. Stevenson's early methods may appear crude, but that does not invalidate his claim as the originator and the first experimenter along these lines. Not only did he invent the pilot cable, but he was the first to demonstrate practically how it could be used in guiding vessels up estuaries and into harbours by means of electric signals from a sunken cable. It was a simple act of justice that these historical facts should be recognised and due credit given to Mr. Stevenson for his valuable pioneer work. A French translation of the statement prepared by the Council has been sent to the Academy of Sciences with the request that it be published in the *Comptes rendus*.

THE Paris correspondent of the *Times* states that the late Prince of Monaco has bequeathed sums of one million francs each to the Académie des Sciences, the Académie de Médecine, the Institut Océanographique, the Institut de Paléontologie Humaine de Paris, and the Musée Océanographique de Monaco.

THE Council of the Marine Biological Association of the United Kingdom has passed a resolution expressing "their respectful homage to the memory of His Highness the late Albert I., Sovereign Prince of Monaco, and their deep appreciation of the great services rendered by him to the advancement of the Science of the Ocean."

THE undermentioned Fellows of the Geological Society have been nominated as Delegates of the Society to the Brussels Geological Congress, 1922: Dr. J. W. Evans, Prof. E. J. Garwood, and Prof. W. W. Watts.

ACCORDING to the *Electrician* the posts of electrical adviser to the Government of India and chief engineer of the Hydro-Electric Survey of India, at present held by Mr. J. W. Meares, are shortly to be abolished.

LORD COLWYN will open the research laboratories of the Research Association of British Rubber and Tyre Manufacturers at 105-7 Lansdowne Road, Croydon, Surrey, on Wednesday, July 26, at 3 P.M.

THE third report of the departmental Committee on Lighting in Factories and Workshops, just issued, deals mainly with the definition of "adequacy" of lighting, which it has already been recommended should be required by Statute and defined by Order of the Secretary of State for different industrial processes. The Committee considers that much work still remains to be done before the regulation of factory lighting can be established on a basis of definite legal minima for illumination. Ample proof is forthcoming of the relation between lighting and production and safety. It is therefore suggested that the chief industries should be invited to assume partial responsibility by sharing in further investigations into the lighting requirements of work in these industries. Meanwhile, as an indication of what is desirable, the Committee furnishes an appendix in which processes in the chief industries are classified as "fine work," requiring 3 foot-candles, and "very fine work," requiring 5 foot-candles. In other appendices values demanded in American codes on industrial lighting are given. It is gratifying to observe that there has already been a substantial improvement in industrial lighting since the Com-

mittee commenced its labours, and there is no doubt that the moderate course they recommend in regard to legal minima will meet with general approval.

MESSRS. GALLENKAMP AND CO., referring to the paragraph in NATURE, July 1, p. 19, on the efforts made by the Museums Association to get rectangular glass jars manufactured in this country, remind us that they are prepared to supply such jars. They have been exhibiting samples at the Museums Association Conference at Leicester this week; we understand that they were unable to make these jars when approached by the Association.

THE attention of archæologists may be directed to a lecture delivered by Mr. G. B. Gordon at the University Museum, Philadelphia, and published in the *Museum Journal* (vol. xii. No. 4), issued by that institution, in which he describes the walls and other antiquities of Constantinople. Mr. Gordon gives a graphic sketch of the history of the city in relation to the existing remains, and his lecture is illustrated by an admirable series of photographs.

A USEFUL list (No. 432) of publications on agriculture and gardening, including some rare herbals, has just been circulated by Mr. F. Edwards, 83 High Street, Marylebone, W.1. It is obtainable free, upon request, of the publisher.

### Our Astronomical Column.

SKJELLERUP'S COMET.—This comet was photographed by Mr. Davidson at Greenwich on June 21 and July 3. The results show that a slight lengthening of the period (previously given as 4.72 years) is needed, and 5.1 years is probably near the truth. This is not unfavourable to the suggested identity with Grigg's Comet 1902 II. Dividing the interval by 4.496 years is obtained as the mean period since 1902, and 5.1 years is quite within the limit of change that might have been produced by Jupiter-perturbations. These would have been considerable early in 1905, and sensible in 1915. The new period is much the same as that of Tempel's Comet, for which the value 5.16 years was found in 1920. This has hitherto been reckoned the second shortest cometary period.

Profs. Crawford and Meyer of Berkeley Observatory, California, find the period 5.53 years for Skjellerup's Comet, but this appears to be somewhat too great, judging by recent observations.

PERIODICAL COMETS.—An investigation has recently been completed by Miss J. M. Young, instructor of mathematics at the University of California, "on the causes which have prevented certain periodical comets being redetected on their predicted returns."

She has brought a number of interesting facts together, with regard to Barnard's Comet of 1884 and Denning's Comet of 1881, and concludes that the most probable period for the former is 5.39 years, and for the latter 8.84 years. Neither of the comets alluded to have been redetected since the years of their discovery, but at certain returns the conditions have been very unfavourable. Miss Young concludes that periodic comets often escape observation owing to the fact that they have not been searched for over a sufficiently large extent of the heavens.

It is to be hoped that greater efforts will be made to rediscover some of the numerous comets of short period which have only been observed at one return. Denning's Comet of 1881 is due in 1925, when the conditions may be favourable; but there is considerable uncertainty as to the date of perihelion.

ROCHE'S LIMIT FOR SATELLITES.—It is not always remembered that the limit assigned by Roche as the minimum-distance of a satellite from its primary (depending on the density of the latter, but of the order of  $2\frac{1}{2}$  times its radius) takes no account of the force of cohesion in keeping the satellite particles together. In the case of bodies of the size of the earth or moon, the disruptive forces would be so large that the force of cohesion might be neglected compared with them; but the case is different when we consider little bodies like Phobos, the inner satellite of Mars. Prof. George Darwin, in his well-known work on the tides, etc., suggested that Phobos was so near Roche's limit that future astronomers might witness its disintegration. Dr. E. O. Fountain gives some useful calculations on the subject in the *Journal of the British Astronomical Association* for May. He assumes as the tenacity of the material forming Phobos about 300 lbs. per square inch, the figure for brick and cement. On this basis he finds that Phobos would still hold together even close to the surface of Mars, while in its present situation a satellite of 200 miles diameter could exist without destruction. He also finds that bodies some 200 miles in diameter could exist without destruction at the inner edge of Saturn's ring, so that the doctrine of Roche's limit can scarcely be invoked to explain the disintegration of the matter of the ring into such tiny fragments as those which appear to constitute the ring particles.

## Research Items.

**ENGLISH GYPSY CHRISTIAN NAMES.**—In the second part of vol. i. of the *Journal of the Gypsy Lore Society*, which has been revived under promising auspices, is a contribution by Mr. E. O. Winstedt on English Gypsy Christian names. This question has hitherto been inadequately treated, and in this branch of Gypsy lore, as in others, there has been a tendency to confine attention too exclusively to Gypsies, and to regard them as more peculiar than they really are. But recent research tends to show that many of their customs, superstitions, folk-tales, and peculiarities of dress are borrowed from the Gorgios among whom they have lived. It is only by foraging among parish registers and similar documents that the remarkable examples collected by Mr. Winstedt can be discovered. Many are certainly of foreign origin, having been brought with them by gypsies as a relic of their travels, and the frequency of Greek names indicates a survival of their sojourn in Greek-speaking countries. Others, again, seem to be English names extensively modified by settlers in this country. These have been traced with much research and ingenuity, and the interest of Mr. Winstedt's paper to philologists and ethnologists is obvious.

**SOCIAL ECONOMICS IN THE PHILIPPINE ISLANDS.**—The relation of religious beliefs and economics to the environment is well illustrated by an important memoir on the Ifugao, who inhabit one of the most isolated districts in the Philippines. They have practically no foreign market for their products, and for their imports they must pay middlemen's profits three or four times over as well as high transport charges. They live in a series of mountain valleys, and this isolation leads to hostility between the groups. The country is fertile, but the climate most uncertain, the latter directly affecting crops and health, and indirectly, it has been a factor which the writer (Mr. R. F. Barton, University of California Publications on Archaeology and Ethnology, vol. xv, No. 5) calls "one of the richest religions in the world," for in order to obtain the favour of good weather and consequent good crops, the Ifugao performs a round of religious feasts, the provision of animals for which is the principal economic motive in his life. The uncertainty of the climate causes much disease, and expensive religious feasts must be given to relieve sickness. "The wealth of the religion has arisen from the variation of climate and the rough and dangerous nature of the mountains, and the perils of the torrents and the landslides. Religion is a great factor, the greatest by far in the commercial activities of the tribe and in the economic activities of the male Ifugao." This survey of an isolated tribe living under special conditions which promote isolation and superstition, is most instructive.

**PARASITOLOGY IN S. AFRICA.**—In the *South African Journal of Science*, vol. xviii., 1921, among the reports of papers read at the South African Association for the Advancement of Science, we note Dr. A. Porter's abstract on the life-histories of some trematodes, including the two African species of *Bilharzia* infecting man and the liver fluke of sheep, the intermediate hosts of which in S. Africa have been ascertained. Prof. H. B. Fantham records observations on parasitic protozoa in S. Africa, including an *Entamoeba*—believed to be new—from the horse.

**MYRIAPODA.**—The attention of workers on this class may be directed to two recently published papers—one by Mr. H. W. Brolemann in Proc. R.

Soc. Edinburg, vol. 42, 1922, on material collected by Capt. W. E. Evans during the Mesopotamia campaign, comprising 17 species, and by Mr. R. V. Chamberlin, in Proc. U.S. Nat. Mus., vol. 60, art. 7, 1921, on the centipedes of Central America.

**CRETACEOUS FOSSIL REPTILES IN INDIA.**—Dr. C. A. Matley, whose services were lent to the Military Accounts Department in India during the later stages of the war, took the opportunity of mapping in detail around the cantonment of Jubbulpore the cretaceous formations locally known as the Lameta beds, which are found underlying the great spread of trap-flows in the Central Provinces. In a paper published in the Records of the Geological Survey of India (vol. liii., Part 2), Dr. Matley shows that in this area the Lametas and trap-flows follow in conformable succession above the so-called Jubbulpore group of the Gondwana system of freshwater beds. Accepting for the Lametas an age of albian to cenomanian, based on correlation with the marine cretaceous beds of western India, the lowest trap-flows are probably not younger than middle cretaceous, while the Jubbulpore group, which was regarded by Feistmantel on palaeo-botanical evidence as middle jurassic, should now be included in the cretaceous system. Dr. Matley's work thus tends to restrict the stratigraphical range previously accepted for these associated formations, and his observations, which were necessarily hurried in places through official duties of an entirely different sort, indicate the desirability of making a detailed re-examination of the strata immediately below and intercalated with the Deccan trap-flows in the Central Provinces of India. The Lameta beds are famous as having yielded the fossil bones on which Lydekker founded the dinosaurian genus *Titanosaurus*. Dr. Matley, in the course of his work, collected further vertebrate remains from previously known localities and discovered some new occurrences. The locality from which General Sleeman, the famous suppressor of "thuggery," first obtained fossil bones in 1828 has been explored systematically with the help of officers lent by the Geological Survey of India, and a large quantity of fresh material has now been obtained, including about 5000 scutes as well as some hundreds of bones, which will certainly yield results on critical examination of the greatest palaeontological interest.

**THE STRUCTURE OF ROCKALL.**—In June last year Dr. J. B. Charcot, cruising in the *Pouquoi Pas?*, visited the little-known island of Rockall, which lies some 200 miles west of the Hebrides. One of his chief aims was to obtain rock samples in the hope of throwing further light on the origin of this curious rock. In this Dr. Charcot was successful, and to an account of his experiences in *La Géographie* for May 1922, is added M. A. Lacroix's report on the geological collections. The prevailing rock of the island is a coarse-grained aegirine granite of a somewhat unusual but not unique type. The so-called rockallite which was described by Prof. J. W. Judd some twenty-five years ago, turns out to be relatively rare. It is a fine grained rock with more aegirine than the normal granite, and it occurs only in patches. Previous to Dr. Charcot's visit the only rock specimens from the island were rockallite. All the rocks contain epidote, which is known also in certain beds in Greenland. Dredgings in the vicinity of Rockall brought to light basaltic rocks, probably the remains of a submerged plateau of basalt, as was suggested some

years ago by Prof. G. A. J. Cole. There can be little doubt that Rockall is the last remnant of a former extensive land surface.

**THE GEOLOGICAL MAPPING OF THE GLOBE.**—In these columns attention has been directed from time to time to the maps issued in connexion with regional memoirs, such as those on Australian states, Sinai, and Mesopotamia. We may now add Lange Koch's geological map of Palaeozoic strata in north-west Greenland, 1:2,000,000, attached to his paper on "The Stratigraphy of North-west Greenland" (*Meddelelser fjo Dansk. geol. Foren.*, vol. v., No. 17, 1920—foreword dated May 1921). In this memoir the earlier Palaeozoic systems are shown to have been involved in the Caledonian folding, which is thus for the first time traced across the Atlantic interval. R. C. Wilson, in "The Geology of the Western Railway" (*Geol. Surv. Nigeria, Bull. 2, 1922, price 17s. 6d.*), includes a coloured map of country north of Lagos, scale 1:250,000, and records Eocene beds near the coast, followed by areas in which composite gneiss is prominent. An immense amount of information as to geological knowledge of the countries bordering the Pacific has been brought together in the Proceedings of the First Pan-Pacific Conference, part 3, published at the office of the Honolulu Star Bulletin, 1921. M. Emm. de Margerie (*Annales de Géographie*, vol. xxxi., p. 109, 1922), in criticising, with a query, "Une nouvelle carte géologique du monde?" points out that the production of such a map is beyond the powers of any one geologist. While indicating defects in a recent publication, he provides valuable notes on material not yet utilised. Hence his essay usefully records a number of publications on regions recently explored.

**GLAZE STORM IN AMERICA.**—The great glaze storm of February 21-23 in the Upper Lake region of the United States of America is discussed by Prof. A. J. Henry and Messrs. J. E. Lockwood and D. A. Seeley of the U.S. Weather Bureau, and is published in the U.S. *Monthly Weather Review* for February. A large amount of damage was done to overhead telegraph, telephone, and other transmission lines in the upper Mississippi Valley and in the States of Wisconsin and Michigan. A serious loss was sustained by shade and ornamental trees and orchards, a loss which cannot be replaced within the lifetime of the present generation. The storm, in common with others of a similar nature, had a cold surface air current which was overrun by a warmer current, the rain which was condensed in the upper current falling upon objects having a temperature some degrees below 32° F. was frozen as it reached them. The diameter of the ice-covered wires varied from a few tenths of an inch to 2.5 in. or more, forming a rod of ice as thick as a man's wrist, and added to this was the weight of icicles which formed along the wires, often very close together, and varying in length from 3 to 12 inches. Often 2 or 3 miles of telephone wires went down at one time. At Oshkosh a small piece of ice-covered branch weighed 2 pounds; without the ice it weighed 2 ounces. In Michigan the ice, sleet, and snowstorm was one of the heaviest on record. Millions of dollars worth of property was destroyed. In many orchards, 25-75 per cent. of the older trees were broken off entirely. At Arcadia a short twig weighing 1 ounce had an ice coating of 2 pounds. Several observers reported the ice coating to weigh 20 to 40 times as much as the supporting branch or wire.

**NEW THEORY OF CYCLONES.**—During the last twenty years our knowledge of the actual movement of the air in a cyclone has increased materially,

and it has become more and more difficult to reconcile it with the theory of cyclone formation advanced by Ferrel 60 years ago. It is only recently that the work of meteorologists in this country and abroad has led to a more satisfactory theory, which has been given a precise form by V. Bjerknes and his son J. Bjerknes, in a series of papers dating from 1917 to 1921. A thoroughly readable account of the present state of the theory will be found in an article by Dr. E. Kuhlbrodt in the issue of *Die Wissenschaften* for May 26. According to Dr. Kuhlbrodt the north polar regions are covered by a cap of cold air which thins out as it extends downwards into temperate latitudes and ends in general about latitude 40°, but may disappear at latitude 50° over a few degrees of longitude. Above the cold cap is a considerable thickness of warm air derived from the south and having a motion to the east. Where the surface of separation of warm and cold air comes down to the earth's surface at an unusually high latitude a cyclone is produced, which is carried to the east by the movement of the warm air. The distribution of wind and weather to be expected in such a region is shown to be in agreement with observation.

**WEATHER AT BLUE HILL, U.S.**—Meteorological observations made at the Blue Hill Observatory, under the direction of Prof. Alexander McAdie, during 1921, are published in the *Annals of the Astronomical Observatory of Harvard College*. The observational data complete an unbroken period of thirty-six years, 1886-1921, and include pressure, temperature, wind direction and velocity, humidity, sunshine, cloudiness, and precipitation. It is estimated that the series should extend over at least fifty years for the establishment of proper normals. A table is given showing advance of the seasons for thirty-six years, 1886-1921. It is interesting to note that the earliest autumn frost for the whole period occurred on August 21 in 1908, and in this year the first snowfall in autumn occurred on December 7, which is the latest of the whole period, an anomaly which would scarcely be expected. The rainfall table giving the monthly amounts for the several years shows a large and varying range of measurement in all months. The average annual rainfall is 46.59 in., ranging from 47 in. for March to 3.20 in. for June.

**A DIFFERENTIAL REFRACTOMETER.**—Messrs. Bellingham and Stanley, Ltd., has constructed a differential refractometer for measuring very small differences between the refractive index of two liquids. The design of the instrument is based on the method described by Hallwachs. The liquids are contained in a glass cell and are separated by a thin glass plate. Light from the source is admitted to the liquid of lower refractive index at grazing incidence on the separating glass plate, which it traverses and then passes through the second liquid at a small angle to the glass plate, the magnitude of this angle depending on the difference between the refractive indices of the two liquids. By means of an observation telescope the axis of which is approximately in the plane of the separating glass plate, the limiting position of the emergent ray from the cell can be observed and the position measured by the screw motion which rotates the cell with its supporting table. In the case of liquids having indices approximating to that of water a difference in index of 0.0001 corresponds to an angle of emergence of about  $\frac{1}{3}$  of a degree. The instrument can thus be made extremely sensitive, and is particularly valuable for the detection of small quantities of impurities in liquids.

## Annual Visitation of the National Physical Laboratory.

A LARGE number of visitors were present at the National Physical Laboratory on the occasion of the Annual Visitation on June 27. The guests were received by Sir Charles Sherrington, president of the Royal Society and chairman of the General Board; and Sir Joseph Petavel, Director of the Laboratory. As is usual on such occasions, the various departments were thrown open and an interesting series of exhibits was arranged, illustrative of the work carried on in the institution.

In the Department of Aerodynamics, exhibits were shown in most of the six wind tunnels. In the largest of these, which has a cross section of 14 ft. x 7 ft., an aerofoil model was set up showing the methods of measuring the lift and drag. The section of the aerofoil under test was on a scale approximately one-fifth of full size. In another channel were shown additions made to the standard type of balance, whereby for one setting of the model the component forces and moments in three directions can be determined. This represents a considerable saving of time in the process of testing. The discontinuous flow of air past a barrier was demonstrated in an effective manner by means of smoke released into the stream of air before it reached the obstacle. Other exhibits included an aeroplane model showing the method of obtaining the distribution of pressure over the wing, an apparatus used for determining the thrust and torque of model propellers, and an ingenious wind direction finder.

The additions to the Engineering Department, consisting of a large experimental shop and a set of offices, have been completed during the year and have much relieved the congestion. Among the exhibits were two machines for testing the efficiency of spur gears and chain drives. In both of these machines the regenerative principle is made use of, so that the power consumption is only that absorbed by the element under test. Thus, to determine the losses corresponding to an actual transmission of 100 h.p., a power of the order of 5 h.p. suffices. The efficiencies can be measured to an accuracy of 0.1 per cent. A new machine for testing reinforced concrete slabs and columns was also shown. The slab specimens can be tested in sizes up to 16 ft. x 6 ft. and 14 inches in thickness, and the columns from 8 to 20 feet in length; the maximum load is 60 tons. It was interesting to note that it was found possible to support the columns by means of knife-edge pivots. During the year, a plant has been completed for the production of asphalt road carpets. This enables the constituents to be mixed accurately in the proper proportions, prior to laying and testing in the standard road-testing machine. Other exhibits in this department included apparatus designed for the measurement of the temperature and pressure of the oil film in lubricated journals, the investigation of heat losses through pipe covers, the determination of the fatigue ranges of stress in materials by the strain method, and for the investigation of the detonation of a mixture of air and liquid fuels in closed vessels.

In the Metallurgical Department, a much-needed extension of space has been provided during the year by the addition of an extra floor on the Wernher building. Considerable attention has been devoted in this Department during recent years to the study of aluminium and its alloys, and examples were shown of an alloy developed at the Laboratory which is specially suitable for aeroplane engines. Pistons and piston rings of this material were on view. A specimen of aluminium was exhibited which had been

submitted many times to an alternate treatment of rolling and melting without any effect on its tensile strength. A very effective experiment was shown on specimens of an aluminium-zinc alloy, which were heated in a furnace at a temperature of 370° C. and then quenched by immersion in water. Within a period of five minutes, a considerable generation of heat occurred—due to the breakdown of an unstable solid phase—which rendered the specimen almost too hot to be held in the hand. An interesting series of micro-photographs, taken during this period, showed the structural changes occurring, which are accompanied by great variation in hardness.

In the section of the department dealing with refractory materials, a new recuperative gas furnace, working under natural draught, and intended for glass melting, was running, while in the section of aeronautical chemistry the viscosity method for characterising deterioration of fabrics was demonstrated. Other exhibits in the Metallurgical Department were a high temperature thermostat arranged for obtaining very slow rates of cooling, and an ingenious relay for controlling furnace currents.

In the Heat Division of the Physics Department, various methods for the measurement of thermal conductivity were demonstrated. These included a new apparatus for dealing with thin sheets of material and for studying the effects of pressure on the thermal conductivity, a large scale apparatus for experiments on insulators for cold storage purposes, and a similar apparatus which has been used for measuring the conductivity of a series of building materials. A method for investigating the convection of heat in transformer oils was shown and also a device for the automatic operation of a ventilating valve with small changes of temperature of the air inside and outside a room. Various types of hygrometers were also exhibited.

In the Thermometry Division a new type of resistance bridge was shown with dials reading to 0.001° C., with a platinum thermometer of 10 ohms fundamental interval.

In the Radiology Division apparatus designed for the X-ray spectroscopic investigation of structure of materials, the measurement of radium salts, the standardising of barium platino-cyanide pastilles, the investigation of protective values of X-ray materials, and the X-ray examination of metals were exhibited.

In the Optics Division, various types of apparatus for measurement and specification of colour were shown. These included a Nutting monochromatic colorimeter, a Lovibond tintometer, a Bawtree colorimeter, and a trichromatic colorimeter for standardisation purposes designed and constructed at the Laboratory. In the latter instrument the mixing of the three primary colours is accomplished by rotating a periscopic prism which passes rapidly in front of three sectorial openings of variable angles in which the coloured filters are placed. Among the exhibits in this division was also a differential refractometer for liquids having nearly the same refractive index, while a new immersion method for measuring the internal bore of a glass tube was also demonstrated.

The Metrology Department (Glass Testing Section) showed a new equipment designed for the accurate calibration of hydrometers against a hydrostatic balance. The liquid in which the hydrometer is immersed is surrounded by a water bath controlled by a thermostat. The whole of this apparatus can be moved under a special balance from the scale pans of which are suspended two plummetts of the same mass



but differing in volume by 100 c.c. The density of the liquid is thus obtained directly by weighing and is compared with the hydrometer under investigation. The balance is of special construction and is provided with inertia bobs at the ends of the arms to counteract the damping due to the movement of the plummets through the liquid. Other exhibits in the Metrology Department included a series of instruments for the precision measurement of engineers' gauges and a vertical interference apparatus for testing the flatness of surfaces, line standards and comparators.

In the Froude National Tank experiments to determine the resistance of a ship form in artificially created waves, and the method of taking continuous records of resistance, pitching angle and pitching period were demonstrated. The object of this work is to obtain data as to the loss of speed of different designs of ships under service conditions. It is interesting to note in this connexion that observations of full size ships have been taken by members of the staff in voyages across the Atlantic in three types of vessels, liners, cargo steamers, and oil tankers. Apparatus was also shown for determining forces on a ship's rudder, the manoeuvring power of a ship's form, and the resistance of a seaplane model on the surface of the water.

Many interesting exhibits were on view in the various sections of the Electricity Department. The Photometry Division showed a method of determining the spectral distribution of energy in arcs having cores of different materials, and of measuring the transmission ratios of coloured glasses intended as standards for ships' navigation lights.

The Alternating Current Section demonstrated the

speed regulation of a D.C. motor by means of a relatively small phonic motor directly coupled to it. The Direct Current Section showed apparatus for experiments on moulded insulators and other insulating materials, tests on buried cables and on energy losses in a 3-core cable with three-phase current.

In the Standards Section, an air gap for dielectric tests on mica and thin sheet materials was shown. This consists of very accurately flat steel plates 12 cms. in diameter, separated by distance pieces of quartz, so as to give an accurately parallel gap. The apparatus can be taken apart and the gap reproduced to within 0.0001 mm. In connexion with the above-mentioned apparatus, a machine of the optical lever type has been evolved for measuring the thickness from point to point of sheets of mica or other thin material.

A standard multivibrator apparatus for radio-frequencies was shown by the same section. In this apparatus a wave with a sharp peak is produced, having a frequency of 1000 per sec. From this, by the help of a highly resonant circuit, every harmonic up to the hundredth may be picked out, thus providing a series of accurately spaced radio-frequencies. The fundamental is kept constant to 1 part in 100,000 by a tuning-fork control. A second multivibrator, which can be controlled from the first one, has a fundamental of 30,000 per second and gives a further series up to 1,000,000 per second.

In the Wireless Section, directional measurements of spark and continuous wave stations were shown, the photographic reception of signals on a string galvanometer, and a new type of thermo-junction ammeter for high frequency.

### Agricultural Research in Great Britain.

THE "assistant principal" at the Ministry of Agriculture, Mr. V. E. Wilkins, has prepared a valuable pamphlet,<sup>1</sup> which gives a useful account of the various forms of agricultural research that are being supported financially by the State. As is well known, the Ministry decided to concentrate research at definite institutions; Rothamsted is concerned with plant nutrition, soil problems, and plant pathology; Cambridge has entrusted to it plant and animal breeding, and animal nutrition; Long Ashton, a branch of the University of Bristol, deals with fruit growing and preserving; plant physiology is dealt with at the research institute attached to the Imperial College of Science; dairying at Reading; animal pathology at the Royal Veterinary College; agricultural zoology at Birmingham; helminthology at the London School of Tropical Medicine; agricultural economics in Oxford; plant breeding, with particular reference to Wales, at Aberystwyth; fruit growing and hops at East Malling; and nursery and market gardening at Cheshunt. Besides these research institutes and stations the Ministry has set up a system of advisory centres from which information in respect of specific subjects is disseminated by advisory officers who also, in many cases, undertake a certain amount of research.

(a) *The Soil and its Effect on Plant Growth*.—This fundamental subject has been entrusted to the Rothamsted Experimental Station, which is concerned, among other things, with the examination of the soil in its relation to bacteria and protozoa, and an account is given of the arduous nature of the research along these lines. The nitrification of

organic nitrogen alone has demanded the services of eight research workers, who in many cases have worked night- and day-shifts. An interesting form of investigation undertaken at this station is concerned with the production of artificial farmyard manure. During the later stages of the war, and subsequently, until the agricultural policy of the Government was altered, there was a prospect of a superabundance of straw, more, in fact, than could be dealt with as food and litter by farm animals. The Rothamsted investigators set about devising a means of converting this straw directly into farmyard manure, and the results are most encouraging, although now, with the reduced area of tillage land, the necessity for such conversion is no longer pressing.

At the same station much work has been done on the influence of colloids on the water-content of soil, and on the mechanical operations concerned with tillage. Most ingenious electrical methods are also being exploited to determine the relation between soil acidity and crop production, and the list of publications that have been issued from Rothamsted during 1920 and 1921 shows the extraordinarily varied character of the work being conducted at this famous station.

(b) *Plant Breeding*.—The problems that are being investigated along this line are concerned with the baking qualities or strength of English wheat, with the production of cereals possessed of a straw stiff enough to stand up under adverse circumstances, with immunity to disease, with the increase of the number of grains in the ear, with the production of harder varieties of winter oats, with the relationship of nitrogen in barley grain to the quality of the produce, and with the production of potatoes immune to wart disease. These problems are being dealt

<sup>1</sup> "Ministry of Agriculture and Fisheries. Agricultural Research and the Farmer: A Record of Recent Achievement." By V. E. Wilkins. Pp. 168. (London: H.M. Stationery Office, 1922.) 2s. 6d. net.

with chiefly at Cambridge; while Aberystwyth, the Welsh plant-breeding station, is concerned principally with the discovery of the production of new and improved herbage plants which must be so important in the West of England from the point of view of pasture and meadows.

(c) *Plant Physiology*.—The chapter on this subject opens with a suggestive discussion on the fundamental principles involved in crop production. These principles are concerned with the causes that determine heavy cropping and light cropping, resistance to disease, and the formation of flower-buds on fruit-trees. The electrical treatment of crops is also receiving attention at Rothamsted, the Harper Adams Agricultural College, and on a station near Dumfries. To quote from the report, "There is no doubt that electrical discharge will increase plant growth, and it is hoped that it will be found possible to continue the patient experimental work that has been going on for some years, for it seems certain sooner or later that electricity must play an important part on the farm in increasing crop production."

(d) *Fruit-growing and Preserving*.—Fruit problems are being dealt with mainly at the horticultural station at Long Ashton and at East Malling in Kent. Much suggestive work has been done on the problem of fruit stocks, a subject that has hitherto been very confused and unsatisfactory. The Paradise stock, for instance, has been proved to be a mixture of several varieties, and it would appear that even the crab stock may be graded into several classes, each of which has a distinct influence on the scion that is grafted or budded on to it. This subject is inseparably connected with the development of the root system, a line of research to which the late

Mr. Pickering gave much attention, showing that it was quite unnecessary to give the amount of attention that is usually bestowed upon planting. This unexpected result appears to have been confirmed at Long Ashton, the original root system playing practically no further part in the growth of the transplanted tree, which seems to develop a new root system independent of the old. Work on ringing, pruning, disbudding, etc., also promises to have an influence on commercial production, while much light is being thrown upon the problem of manuring of fruit. This station has also contributed largely to our knowledge of the factors that determine the production of high-grade cider and perry.

(e) *Plant Diseases*.—In no department of the Ministry's scheme has more activity been shown than in the direction of plant diseases. At the School of Botany in Cambridge special attention has been given to the silver leaf disease, a trouble that is increasing markedly in this country, and is now no longer confined to plums, but has spread to apples and other fruit-trees. How destructive the disease may be is proved by the fact that an apple-orchard of about 6 acres, near Wisbech, showed more than 1000 trees attacked by this disease, the cause being attributed to carelessness in pruning and the neglect to protect the wounds thus caused.

Space does not permit of the publication of details in the departments of animal husbandry, animal breeding, dairying, animal diseases, and agricultural economics, but enough has probably been said to show what an enormous change has come over the country in respect of the provision for agricultural research under the enlightened policy pursued by the Ministry of Agriculture.

## The Magnetic Work of the Carnegie Institution.<sup>1</sup>

By Dr. C. CHREE, F.R.S.

THE primary object of the volume referred to below is to chronicle the results of observations made on land by members of the Department of Terrestrial Magnetism of the Carnegie Institution, Washington, from 1914 to 1920. During that period 1747 stations were occupied, bringing up to 4028 the number of land stations occupied since the world survey began in 1905. Even the general reader will find much to interest him in the field observers' reports on pp. 98-222. Mr. F. Brown, for instance, who travelled over large areas in China, Mongolia, Manchuria, Upper Burma, the Cameroons, and French Equatorial Africa, and who crossed Central Africa from Angola to Mozambique, relates adventures with brigands, lions, witch doctors, and native kings.

There is also a general account of the land instruments employed, references being made to earlier volumes for constructional details. Plate 2 gives illustrations of the instruments supplied by the Department to Captain Roald Amundsen's *Maud* expedition. On p. 9 there is an explanation of the two standards which have been used, the earlier denoted by C.I.W. (Carnegie Institution, Washington), the later by I.M.S. (International magnetic standards). The use of the latter term for standards which have not received international sanction is somewhat open to criticism.

The observational results occupy some 67 pages, and later in the volume there is a detailed description of the stations. Some of the more picturesque places visited are illustrated in seven plates.

<sup>1</sup> Researches of the Department of Terrestrial Magnetism, vol. iv.; Land Magnetic Observations 1914-1920. By Dr. L. A. Bauer and others; and Special Reports. (Publication 175). Pp. vi+475+9 plates. (Washington: Carnegie Institution, 1921.)

Mr. J. A. Fleming describes the construction at the headquarters of the department, at Washington, of a new non-magnetic building for experimental work. It is of considerable size, 28 ft. × 53 ft. ground area, of double-walled concrete. Provision is made for the supply of water, gas, compressed air, and electric circuits for direct and alternating current. The cost, exclusive of the internal equipment, was 8500 dollars. A magnetic survey made after the completion of the building showed differences of 2' in dip and 25γ in horizontal force between the north and south ends.

Mr. H. W. Fisk discusses errors arising from minute pivot defects in dip needles. He advocates the use of at least four needles at each station, so as to recognise with certainty when an individual needle becomes faulty.

A description by Mr. S. J. Barnett of a new sine galvanometer for determining H (horizontal force) is of special interest at the present moment. The construction of similar instruments has been simultaneously in progress in America, Japan, and England. The instrument described by Mr. Barnett is much smaller than that recently described to the Royal Society by Mr. F. E. Smith. Its coils, of approximately 30 cms. diameter, are wound on Carrara marble. An approximation is made to the Helmholtz arrangement, but the coils are really spirals. It is hoped to measure H with an error less than 1 in 10,000. A preliminary comparison with the I.M.S. standard mentioned above gave a discrepancy of only 0.7%, or 1 part in 25,000, but the constants of the instrument are as yet to some extent provisional.

Mr. J. A. Fleming also deals with the results of comparisons, direct and indirect, between Carnegie Institution instruments and the standard instruments

in use at a number of observatories. He claims that the results show, first, that the Carnegie Institution standards are in every way satisfactory, and second, that "the absolute precision obtainable with carefully designed magnetometers and (dip) inductors, provided instruments are carefully used and comparisons are made with reliable standards at least every two or three years, is of the order 0.2 in declination and inclination and of the order 0.00015H (i.e. 37 in England) in horizontal intensity." If this be true, the gain in accuracy to be hoped for from coil instruments is not great. If, however, as stated on p. 468, a complete observation of H with the coil instrument occupies only 2 minutes, its use at an observatory would represent a great economy of time, always

provided little time is spent on keeping the apparatus up to the mark.

However this may be, what is really more wanted is a coil instrument for measuring V (vertical force). Base line values of V curves are at present dependent on dip circles or inductors. Even if the accuracy claimed by Mr. Fleming for dip inductors be conceded, it must be remembered that an error of 0.2 in the dip at a place where the value of H is only 0.03 (the approximate value at the base station of the Australasian Antarctic Expedition 1912-13) leads to an error of about 90% in V. Thus a coil instrument which could give V directly, to within  $\pm 5\%$  even, would be an immense improvement on a dip inductor for use in high latitudes.

### New Social Coleoptera.<sup>1</sup>

By Dr. A. D. IMMS.

IF we regard as truly social only those insects in which the parent, or parents, live with their offspring, protecting and feeding them, there have been known hitherto but three groups of beetles which come into this category, namely, the Platypodidae, Scolytidae, and Passalidae. Prof. W. M. Wheeler has recently added to the list two genera of Silvanid beetles belonging to the family Cucujidae, discovered by him in British Guiana. The beetles in question are *Coccidotrophus socialis* and *Eunaisibius wheeleri* both of Schwartz and Barber. The bulk of his observations concern the first-mentioned insect, the other species being apparently rare. The beetles enter the hollow petioles of a Leguminous tree *Tachigalia* and either bore their way in, or gain admittance through perforations previously made by other insects. They enter either as a single pair, or one beetle enters and is very soon joined by an individual of the opposite sex. Upon taking possession of their future habitation the beetles remove any loose pith, or the remains of previous tenants, by pushing this debris into the pointed ends of the cavity by means of their flattened heads. This behaviour brings the insects into contact with the outermost layer of pith adhering to the walls of the cavity, and certain strips of nutritive parenchyma. The latter tissue forms the food of the beetles, and is also shared by young Coccidae of the species *Pseudococcus bromeliae*, which soon begin to enter the petiole-cavity. By means of the feeding action of the beetles, the strips become converted into grooves, the coccids stationing themselves in a row in each groove. The beetles carefully avoid soiling their food material and store their frass in the areas between the grooves. They lay their eggs along the frass ridges, and the larvæ which hatch out feed upon the same nutritive parenchyma as their parents. When mature, they

construct brown cocoons within which pupation occurs. The beetles emerging from the latter remain in the petiole with the original pair; they mate and produce eggs and larvæ in turn, thus leading to the climax stage of the colony, which may eventually consist of several dozens of beetles of both sexes, and many larvæ and pupæ in all stages of development. The Coccidae also increase in number, so that the cavity of the petiole sometimes becomes crowded with inmates. In the meantime, the old and exhausted beetles die off, and their bodies are consigned to the refuse accumulations already mentioned. When this crowded condition is reached, beetles begin to leave the colony either singly or in pairs and, seeking other petioles, thus found new colonies.

Both the larvæ and imagines of the *Coccidotrophus* solicit honey dew from the coccids by "stroking" the latter by means of the antennæ. The relations of the beetle to the coccids, moreover, are physiologically similar to those of symphyle beetles to host ants that supply them with regurgitated liquids. *Coccidotrophus*, like the symphyles, has specially modified antennæ and labium, such modifications occurring in both the larvæ and adults. This type of relationship with Coccidae has not been noted hitherto in any Coleoptera and, apart from ants, very few insects are known to have developed the ability to solicit honey dew from among the Homoptera.

It appears that the Silvanids have a more primitive social life than any of the three families of beetles previously alluded to, but there is no definite preparation of larval food by the parents. Their colonies represent a stage in social development intermediate between the families mentioned and the merely gregarious species of Cucujidae. For further details, and many interesting observations on the numerous and heterogeneous "biocœnoses" of other insects associated with the plant *Tachigalia*, the reader is referred to Prof. Wheeler's original paper.

<sup>1</sup> W. M. Wheeler, "A Study of some Social Beetles in British Guiana and of their Relations to the Ant-Plant *Tachigalia*," *Zoologica*, New York, vol. iii. Nos. 3-11, Dec. 24, 1921.

### Spectroscopic Studies of Stellar Velocities.<sup>1</sup>

By Dr. WILLIAM J. S. LOCKYER.

IN order to determine the distribution and motion of stars in space it is necessary to know four important facts about each star. The first is its position, known as its Right Ascension and Declination; the second is its proper motion, i.e. the move-

ment at right angles to the line of sight; the third is the radial velocity or movement towards or away from the earth; and lastly, the parallax or distance of the star from the earth.

During the last few years the accumulation of a large amount of such data, extending over many years, has led astronomers to the important problem of investigating the systematic motions of the stars

<sup>1</sup> "The Radial Velocities of 594 Stars," Publications of the Dominion Astrophysical Observatory, Victoria, B.C. (vol. 2, No. 1), by J. S. Plaskett, W. E. Harper, R. K. Young, H. H. Plaskett (Ottawa, 1921).

and their distances, thus leading to our knowledge of the distribution of stars in space, and finally to the structure of the universe.

At the present time, however, data are most lacking regarding stellar radial velocities, and any attempt to increase our knowledge in this respect deserves particular attention. It is, therefore, very satisfactory to know that, when planning the equipment of the Dominion Astrophysical Observatory of Victoria, B.C., the first consideration was given to its suitability for this class of work, which it is proposed to make the great feature of the new institution. Quite recently the first volume of measures has been published, and this comprises the determination of the radial velocities of 594 stars between the fifth and eighth magnitudes, the velocities of which have not been measured before.

The work was commenced in May 1918 by the Director of the Observatory, Dr. J. S. Plaskett, and Dr. R. K. Young. In the following year Mr. W. E. Harper and Mr. H. H. Plaskett joined the staff, so that this volume is the outcome of the endeavours of these four observers, who together made the observations, the measurements and the reductions of the spectrograms, as no computing assistance was available.

The introduction to the volume describes briefly the telescope, the spectrograph, the observing arrangements, measuring machines, wave-lengths of spectral lines employed, etc. The telescope was the large 72-inch reflector, and the spectroscope was used with the Cassegrain combination of the telescope. The regulation and control of the temperature in the spectrograph was at first attained by the use of a mercury contact thermometer actuating a special relay, but this was replaced later by the installation of a Callendar recorder. Considerable attention was devoted to the wave-lengths of the lines employed in the reduction of the spectrograms, and the system eventually adopted was one developed by Dr. Young, which is to some extent a compromise of different methods and systems used by various observers. Tables showing the standard wave-lengths employed are given, and they indicate the wave-lengths used for B-type stars and for A- to F-type stars, together with a list of iron comparison lines.

The work accomplished may be briefly summarised by referring to the results of the measures which are brought together in various tables. The first contains the mean velocities, with their probable errors,

of all stars, 537 in number, assigned to be of constant velocity, including their positions, magnitudes, spectral types, etc. Next follows a summary table of the velocities of the systems of all spectroscopic binaries, the orbits of which have been determined at the Victoria Observatory. Table IV. gives complete information as regards the details of all the 3287 radial velocity plates of the 537 constant velocity stars, an average of 6.1 plates per star. This information is concise, compact, and in a convenient form, and will be valuable for detail reference when required. Similar detailed information is given in Table V. with respect to 206 plates of 35 probably binary stars.

It is interesting to make a short reference to the accuracy of the determinations of the radial velocities, because this accuracy depends to a very great extent on the definition of the lines in the star's spectrum under examination. Thus, some spectra have clean-cut lines which render their measurement easy, while others exhibit fuzzy lines, making measurements difficult. The authors have, therefore, divided the probable errors into three classes. The first includes stars of spectral types between Fo and M (excluding some early F stars) which give the most trustworthy values; the probable errors for these range between  $\pm 0.1$  and  $\pm 1.0$  kms. for the mean velocity obtained from all plates, and between  $\pm 0.2$  and  $\pm 2.5$  kms. for a single plate. The second main class includes about one-fourth of the A-type, about two-thirds of the B-type, and the early F-type mentioned above. The probable errors for this group are given as ranging from  $\pm 0.5$  to  $\pm 1.5$  kms. for the mean velocity, and from  $\pm 1.2$  to  $\pm 3.5$  kms. for a single plate.

The last group embraces mostly A-type stars with the addition of a few B- and O-type, the lines of which are diffuse, broad, and frequently weak. For these the probable errors range from  $\pm 1.0$  to  $\pm 3.8$  kms. for the mean and from  $\pm 2.5$  to  $\pm 10.0$  kms. for a single plate.

The original programme as to the number of photographs of the spectrum of each star to be secured, namely, six plates for each star with well-defined lines and eight or ten plates with poor lines, was almost carried out; the whole system of velocities here deduced is therefore homogeneous and a high grade of accuracy has been maintained. The radial velocity values are the result of a great amount of painstaking care, and their early publication is evidence of the industry that has been displayed in all stages of the research.

### Geology of Antarctic Lands.

A USEFUL reference to recent summaries of the geological features of Antarctica occurs in the Proceedings of the first Pacific Conference, part iii. p. 644 (1921). It is unfortunate that the various researches based on the results of different British expeditions have not been carried out in a common clearing-house and published as an interlocking series. At present three sets of quarto publications are appearing in our libraries, two of them under the auspices of the Royal Society of Edinburgh, and one under those of the Trustees of the British Museum. Mr. J. M. Wordie's observations on the Weddell Sea area (Shackleton expedition, 1914-17) have been already noticed (NATURE, vol. 109, p. 218). The geological results of the expedition from the Falkland Islands in 1913, financed by Messrs. Salvesen of Leith, are now described by the leader, Mr. D. Ferguson ("Geological Observations in the South Shetlands, the Palmer Archipelago, and Graham Land," Trans. Roy. Soc. Edin., vol. liii. p. 29, 1921).

The unrest in the earth's crust in Oligocene and Miocene times is illustrated by great outpourings of basalt in the South Shetland Islands. The later lavas of the series are notably columnar, and are correlated with similar rocks in Patagonia. Volcanic activity continued almost down to recent times, and there is a series of andesitic tuffs and lavas that go back to Jurassic or early Cretaceous age. The photographic landscapes in this memoir are of unusual excellence. The rocks collected abundantly by its author are described by G. W. Tyrrell in a separate memoir (*ibid.* p. 57). They include the varied intrusive masses of Graham Land and its group of islands, and the red adamellite of Mount Theodore, "the most imposing natural feature" of the district. Mr. Tyrrell regards these older igneous rocks as distinctly Andean in type.

Dr. H. H. Thomas (*ibid.* p. 81) deals with the rocks and minerals collected from islands of the same region by Mr. Innes Wilson, of the Falkland Islands, in

1916-17, including a high-grade copper ore from a boulder near Port Lockroy on the Neumayer Channel. The description of the varied lavas of Deception Island in both this and Mr. Tyrell's paper is surely an argument in favour of collation and co-operation.

The reports of the British Antarctic ("Terra Nova") Expedition of 1910, published by the British Museum, are concerned, however, with another quadrant of the antarctic region. In the geological series, Nos. 3 and 4, recent and older sedimentary deposits are described by Mr. F. Debenham, from

his personal observations as geologist to the expedition. Metamorphic rocks are dealt with in No. 5; but their relationships in the field are as yet but little known. Dr. A. Smith Woodward's account (No. 21) of "Fish remains from the Upper Old Red Sandstone of Granite Harbour," including Bothriolepis, provides more definite information. The remoteness and perils of the district excuse the uncorrelated nature of the results, and no doubt also explain the handsome method of their presentation in the year 1921-22. G. A. J. C.

### Durability of Optical Glass.

By Dr. JAMES WEIR FRENCH.

IT is the custom of optical glass manufacturers to issue long lists of types characterised by their optical constants, without much regard to their qualities of durability, which are only occasionally indicated. To the practical computer these lengthy lists are not imposing. Experience has taught him that the number of sufficiently trustworthy types is really very limited, and that only in exceptional circumstances, that fortunately do not frequently arise, may an extension of his list be justified. But while the possibility remains that glass of an unstable kind may be used in the construction of his instruments, the optician has cause for anxiety in the knowledge that his reputation as well as the glass may become tarnished.

The British Scientific Instrument Research Association, the function of which is to provide for the industry the leaven of science, has been charged with the investigation of the durability of glass. According to the admirable report<sup>1</sup> that has recently been issued, "the object of the Research was to determine how far it was possible to establish simple tests by which the durability of different types and varieties of optical glass could be quickly ascertained without awaiting the results of experience by actual use over an extended period." To what extent this object has been attained may be realised from the frank confession at the conclusion of the report, that "it is not possible to recommend any simple test by which the durability of an optical glass can be determined, with such reliability as to avoid the chance of misleading users of the glass in some one or other application of it." With this pessimistic conclusion it is difficult to agree, as the object has already been attained in the workshop, if it is agreed that it is the reflecting or transmitting qualities of the surface with which the optician is concerned.

From the report it appears that numerous tests of Continental and British types of optical glass have

been examined by the iodocein test of Mylius, the autoclave water and steam tests at four and two atmospheres of pressure, and the "dimming" test evolved by the Royal Arsenal Directorate of Chemical Inspection, which co-operated in the research. This dimming test is really an elaboration of the Zschimmer test. The three tests as applied indicate merely to what extent alkali can be dissolved from the surface, and, as is to be expected, the flint glass types appear more durable than the crown types—a conclusion that is misleading, as the report rightly indicates. Our industrial atmosphere unfortunately contains sulphuretted hydrogen, and if in the dimming test an atmosphere more representative of reality had been employed, the flint types would have been placed more nearly in the order accorded to them by Faraday.

The report confirms the interesting fact, already known in the workshop, that in the glass-polishing process alkali is dissolved from the surface layer, which, with a few exceptions, becomes more durable. Workshop experience shows that a new cloth polisher tested with litmus will usually be found to be slightly acid; after a few hours of working it will be neutral; and thereafter it becomes strongly alkaline. A pitch polisher reacts similarly, but it does not retain the dissolved alkali to the same extent.

The optician is concerned in practice not so much with those so-called optical glasses that are visually affected by the tests referred to, as with those that are labelled as being durable and unaffected. If a well-polished specimen of the most durable crown glass be boiled in water at atmospheric pressure for two hours and its reflecting power be then tested by means of a multi-reflection photometer, a loss of 1 per cent. per reflection may be detected. After boiling for eight hours, the loss will be about 2 per cent., but thereafter the rate diminishes.

The drastic autoclave tests adopted in the research are not necessary to demonstrate how many of the types included in the optical glass-makers' lists are vitreous substances of but little value and a source of danger to the unwary.

### Volcanic Activity in Nigeria.

REPORTS have been received by the Governor from Mr. A. A. Reading, of the Bibundi Estate, of a recent volcanic eruption in the Cameroons Mountain, near the coast of Nigeria. Repeated earthquake shocks commencing on February 3 last were followed by an eruption at an altitude of about 4000 feet on the north-west side of the mountain, giving rise to a lava stream which flowed down in the direction of the Bibundi Estate, and entered the plantation area on March 3. The lava extended, roughly, one-third of a mile out to sea, and huge

columns of steam were continually ascending. Attempts to photograph the scene failed on account of the dense smoke and ashes. The centre of the group of craters was estimated to be distant 9900 yards from the house at Bibundi Beach on a magnetic bearing of 128°, and the height above sea-level was believed to be about 4150 feet.

In May the northern stream was still advancing, and threatened to reach the sea along the water-courses on each side of Dollmanshohe. Sometimes there was a loud noise resembling that of a blast

<sup>1</sup> Report of an Investigation on the Determination of the Durability of Optical Glass carried out by T. Haigh. Pp. 51+10 plates. (British Scientific Instrument Research Association, 26 Russell Square, W.C.1.) 7s. 6d.

furnace; at other times there was a series of explosions that sounded like big guns firing. On some days there were showers of ashes, which were so heavy that they broke the leaves of the palm trees.

When on open ground the lava stream came along like a wall of red-hot rock 30 or 40 feet high, which kept falling away in front as it advanced, but when it came down the deep ravine between Wernerfelde and Retzlafelde, it flowed like a red-hot river moving at the rate of about 2 feet a minute. Mr. Reading threw a big stone on it to see if it would make a splash, but although it was moving and looked liquid, the stone bounded off just as if the lava were solid rock.

Since the outbreak of the volcano no severe earthquake shocks have been experienced, though the house was frequently felt to be shaking and two or three slight shocks were noticed.

Mr. Reading went round the edge of the lava in a canoe where it projected into the sea. He could not approach nearer than about 300 yards on account of the heat. At that distance the sea was so hot that he could not put his hand into it, and dead fish abound.

### University and Educational Intelligence.

**BIRMINGHAM.**—Applications are invited from graduates in medicine of the University, of not more than five years' standing, for the Walter Myers travelling studentship (value 300*l.* for one year) for research in any branch of medicine or pathology approved by the selection committee. The studentship is tenable at any university, laboratory, or other approved institution, and the holder must devote his whole time to research. Full information is obtainable from the Registrar of the University.

**LEEDS.**—A Gas Research Fellowship, value 200*l.* per annum, established by the Institution of Gas Engineers at the University of Leeds for the prosecution of post-graduate research in gas chemistry, has been awarded to Mr. S. Pexton. For the last two years Mr. Pexton has worked in the department of coal gas and fuel industries of the University.

**LONDON.**—Applications are invited for the William Julius Mickle fellowship, which is of the value of at least 200*l.*, and awarded annually to the man or woman resident in London and a graduate of the University, who, in the opinion of the Senate, has done most to advance medical art or science during the preceding five years. Particulars respecting the appointment may be obtained from the principal officer of the University. All applications for the fellowship must reach him by, at latest, October 2.

**ST. ANDREWS.**—The honorary degree of LL.D. will be conferred on the Prince of Wales on the occasion of his contemplated visit at the end of September. There will be no public graduation ceremony.

THE Commissioners of the Exhibition of 1851 announce that Senior Studentships for 1922 have been awarded to the following: Mr. J. S. Buck (Liverpool), research student in chemistry, of the University of Liverpool; Mr. G. T. R. Hill (London), research student in aeronautics, of the University of London, University College, late experimental engineer and pilot to Handley Page, Ltd.; Mr. A. E. Ingham (Cambridge), research student in mathematics, of the University of Cambridge; Mr. J. E. Jones (Victoria), lecturer in mathematics, of the University of Manchester; and Mr. C. E. Tilley (Adelaide and Sydney), research student in geology, of the University of Cambridge. Science Research Scholarships (Overseas) have been

awarded, on the nomination of the institution mentioned, as follows: Mr. J. M. Luck (University of Toronto), for biology; Mr. W. H. McCurdy (Dalhousie University), for physics; Mr. D. F. Stedman (University of British Columbia), for physical chemistry; Miss Marie Bentivoglio (University of Sydney), for crystallography; Mr. J. S. Rogers (University of Melbourne), for physics; Mr. J. C. Smith (University of New Zealand), for chemistry; and Mr. I. Low (University of Stellenbosch), for meteorology.

**DR. W. D. HENDERSON**, professor of zoology in the University of Bristol, has been appointed Ray Lankester Investigator at the Marine Biological Laboratory, Plymouth.

THE *Chemiker Zeitung* announces that the Society of Friends of the University of Jena has at its first annual meeting granted a sum of 700,000 marks for scientific purposes and 200,000 marks for the assistance of students. Of the first sum, 200,000 marks is for the Chemical Institute.

An appointment is to be made by a committee of the Royal College of Physicians of London and of the Royal College of Surgeons of England of a Streatfield research scholar. The scholarship was founded for the promotion of research in medicine and surgery and is of the annual value of about 250*l.*, tenable at the discretion of the committee for three years. Applications, marked "Streatfield Scholarship," and stating the nature of the proposed research and where it will be carried out, should reach the Registrar of the Royal College of Physicians of London, Pall Mall East, S.W.1, on or before October 2.

STATISTICS for 1920-21 of 93 State Universities and State Colleges have been published by the United States Bureau of Education (Bulletin, 1921, No. 53), under the heads—teaching force, student enrolment, and property and income. Most of these institutions were originally "Colleges for Agriculture and Mechanic Arts," and their agricultural and engineering schools are still far larger than all their other professional departments put together; but nearly all of them have departments of arts and sciences, and seventeen have graduate departments with not less than 50 students each. The largest teaching staffs are maintained in the following universities: California (1016), Cornell (905), Minnesota (837), Illinois (780), Wisconsin (731), Ohio (569), and Michigan (543). Thirty-four other institutions have more than 100 teachers. Of the total number of teachers (about 15,000) one-sixth are women. Salaries of presidents (most of whom are provided with free quarters in addition) range in general between 5000 and 12,000 dollars; those of professors between 2000 and 6000. The student (regular term) enrolments in the seven large universities named above were: 14,445, 5771, 11,282, 8739, 7573, 7584, and 9611. Forty-two other institutions have enrolments exceeding 1000. Women students constitute nearly a third of the total. Besides the regular term students there are some 60,000 summer school students, of whom nearly two-thirds are women. Almost every one of the State universities and State colleges holds a summer school. Endowments exceeding, in each case, five million dollars, are possessed by the Massachusetts Institute of Technology, Cornell University, and the universities of Texas, California, and Washington. It is remarkable that in no less than five States the private benefactions received by the State universities and State colleges during the year amounted to one-fifth or more of their total incomes.

## Calendar of Industrial Pioneers.

July 16, 1824. Simone Stratico died.—An Italian engineer and mathematician, Stratico held professorships at Padua and Pavia, where he assisted Volta in his physical work, while under the rule of Napoleon he became an inspector of roads and bridges. He was also the author of works on hydraulics.

July 17, 1794. John Roebuck died.—The friend of Joseph Black and Watt, Roebuck was trained as a doctor and practised for a time at Birmingham. Turning his attention to chemical manufacture, he was successful in introducing leaden chambers in place of glass ones in the manufacture of sulphuric acid. In 1760 he founded the famous Carron Iron Works on the river Carron in Stirlingshire, but though a sound metallurgist, his business operations failed financially.

July 17, 1857. Pierre Louis Frederic Sauvage died.—Remembered as one of the independent inventors of the screw propeller, Sauvage was well known as an ingenious mechanic, and had works in the neighbourhood of Boulogne. He patented the propeller in 1832, but reaped no benefit from it; and though granted a pension by Louis Philippe, the failure of his scheme affected his mind and he died in an asylum. A statue of him was erected at Boulogne in 1881.

July 17, 1886. David Stevenson died.—A member of the well-known Scottish family of lighthouse engineers, Stevenson was trained as a mechanic, made surveys, wrote scientific papers, and with his brother Thomas (1818–1887) designed and built 28 beacons and 30 lighthouses in various parts of the world. He also took a leading part in the introduction of paraffin in place of colza oil.

July 17, 1891. Willoughby Smith died.—Entering the service of the Gutta-Percha Company in 1848, Smith superintended the making and assisted in the laying of the first submarine cables, and became chief electrician and manager of the Telegraph Construction and Maintenance Company. He made experiments on coating wire with gutta-percha, introduced improvements in cable manufacture, and was connected with the various Atlantic cable enterprises. In 1882 he served as president of the Society of Telegraph Engineers, now the Institution of Electrical Engineers.

July 19, 1879. Louis Favre died.—The son of a Swiss carpenter, Favre learned his father's trade and afterwards became noted as a builder of railways in the south of France and in Switzerland. In 1872 he became the engineer of the St. Gothard's tunnel, in the construction of which he made use of compressed air as suggested by Colladon. This tunnel is 14,900 metres in length. Favre's death occurred suddenly in the tunnel a short time before its completion.

July 22, 1869. John Augustus Roebling died.—One of the greatest bridge builders of last century, Roebling was a native of Germany, being born on June 12, 1806, at Mulhausen, Thuringia. He graduated from the Polytechnic School at Berlin, and in 1831 emigrated to the United States, where, after experience in canal and railway engineering, he founded a wire-rope manufactory. He constructed a wire-rope suspension aqueduct and a bridge over the Monongahela River, and suspension bridges over the Niagara Falls and the Ohio River, the latter having a span of 1057 feet. The success of his work led to the acceptance of his design for a great bridge over the East River to connect New York and Brooklyn, and it was while superintending the laying out of one of the towers of this bridge that he received the injury from the effects of which he died. E. C. S.

## Societies and Academies.

LONDON.

Royal Microscopical Society, June 21.—Prof. F. J. Cheshire, president, in the chair.—A. Chaston Chapman: The use of the microscope in the brewing industry. The use of the microscope for research and control purposes has been directly responsible for greater technical advances and, indirectly, for more far-reaching discoveries in brewing than in any other industry. The larger breweries have laboratories in which both chemical and biological tests are carried out and much time is devoted to the examination of yeast, to the forcing of beers as a test of stability, to the testing of the efficiency of the air-filters, etc. The successful conduct of brewing operations depends almost entirely on such control work. The introduction of the microscope into the brewery as the result, chiefly, of Pasteur's investigations, has been responsible for the replacement of empirical methods by processes based on scientific knowledge.—J. Strachan: The microscope in paper-making. The microscope was introduced into the industry by amateur microscopists more than a century ago, and during the past twenty-five years, which have witnessed the application of exact scientific methods to paper-making, the technologist found the microscope already in common use. The microscope is used in the paper-mill chiefly for the analysis of paper and of its raw materials and in controlling the blending and preparation of these substances. It has also been applied to the beating process, which is largely a matter of colloid physics, and to sizing, dyeing, impurities in air and water, the valuation of new raw materials, etc. In spite of recent research work, which indicates that the cellulose basis of plants is of a uniform chemical composition, and that X-ray spectrographic methods have proved this substance to be of definite crystalline character, the constitution of cellulose remains unsettled. No important work had been done on its refractive index (about 1.555). Microscopic work on this matter and the application of the polariscope and ultra-microscope would probably yield important evidence.

Mineralogical Society, June 27.—Dr. A. Hutchinson, president, in the chair.—A. Brammall and H. F. Harwood: The Dartmoor granite; its accessory minerals and petrology. Minerals of general occurrence: tourmaline, ilmenite, magnetite, apatite, monazite, garnet, zircon [(1) in water-clear, small crystals, (2) in tawny, zoned, larger, and more abundant crystals], pyrites and pyrrhotine. More restricted: fluor (colourless, blue, and purple), topaz, cassiterite, andalusite, sphene, anatase, barytes. Biotite is abundant; muscovite is scanty. Streams have yielded, in addition, rutile, brookite, and blue-green anatase. Analyses are given of granite types (bulk), biotite, porphyritic feldspars (baryta-bearing), and some accessory minerals. In the tor area (Haytor-Widecombe), the granite occurs as successive sheets or flows, differing appreciably in chemical composition. The texture becomes coarser, porphyritic feldspars become more abundant and richer in plagioclase content, and the percentage of biotite and accessories increases with vertical descent in a flow. The relationship of topography to pseudo-bedding, jointing, veining, and probable faulting is discussed.—W. F. P. McLintock and F. R. Ennos: On the structure and composition of the Strathmore meteorite. From microscopical examination of thin sections of this meteorite, stones of which fell in Perthshire and Forfarshire on December 3, 1917, the structure is that of the intermediate chondrite group (Ci). An apatite-like mineral is present. Detailed chemical analyses of the magnetic and non-

magnetic portions agree closely with the Barotí group.—H. F. Collins: On some crystallised sulphates from the province of Huehva, Spain. Analyses are given of pisanite, chalcantinite, coquimbite, copiapite, voltaite, roemerite, etc., from various pyrites mines. Experiments were made to determine the range of miscibility of iron sulphate and copper sulphate in mixed crystals of pisanite ( $R'SO_4 \cdot 7H_2O$ ) and chalcantinite ( $R'SO_4 \cdot 5H_2O$ ).—H. Hilton: The graphical construction of the constants of a shear. A graphical construction, based on the gnomonic projection, is given for obtaining the two circular planes of a shear, when the initial and final positions of two crystal-planes or edges are known.—H. Hilton: A note on crystallographic notation. A notation is suggested for the 32 crystal-classes and the 230 groups of movements, which is easy to write and print, and is based on the fundamental principles of structure-theory.—A. F. Hallimond and E. G. Radley: On glauconite from the Greensand near Lewes, Sussex; the constitution of glauconite. A boring through 325 feet of gault at Iford Manor yielded glauconite sand. A discussion of the analysis of this material and of some previously published analyses leads to the formula  $R_2O \cdot (4R_2O_3 \cdot RO) \cdot 10SiO_2 \cdot nH_2O$ .—L. J. Spencer: Ninth list of new mineral names.

## DUBLIN.

Royal Irish Academy, June 12.—Prof. Sydney Young, president, in the chair.—G. H. Carpenter and Miss K. C. J. Phillips: The Collembola of Spitsbergen and Bear Island. The collections made by the Oxford University Expedition of 1921 include ten species of Collembola, one of which—*Folsomia sexoculata*—is an addition to the known fauna of Spitsbergen, while another—an *Isotoma* closely allied to the common *I. viridis*—taken on Bear Island is new to science. Twenty species of these insects have now been recorded from Spitsbergen: seven of these have been found also on Bear Island, which possesses, in addition, four species not yet detected on Spitsbergen. Sixteen members of this arctic fauna are represented in Great Britain and Ireland, while thirteen occur in Greenland and North America. Such distributional facts suggest paths of migration to the north of the Atlantic.

## EDINBURGH.

Royal Society, June 19.—Prof. F. O. Bower, president, in the chair.—J. Stephenson: On the pharyngeal glands of the Microdrili (Oligochaeta). The chromophil cells in the anterior segments of the body of the Microdrili have, contrary to the usual view, no direct communication with the alimentary canal, and are not cells of the alimentary lining which have retreated from the epithelial layer while still retaining their connexion with it by means of a long thin neck which acts as a ductule. They are mesoblastic in origin; in the encytracoids (where they form the septal glands) their secretion reaches the pharynx by percolating along special strands of tissue; in all other cases special channels are wanting and the products of the cells simply mix with the coelomic fluid; their secretion is thus an internal secretion.—W. Peddie: On self light, fatigue, inhibition, and recurrent visual images. Formal development of the trichromatic hypothesis is made beyond the stage at which it was left at the time of Helmholtz's death. Phenomena of contrast and after images, steadily decaying or oscillatory, and phenomena of fatigue and inhibition, are treated. The trichromatic theory of colour vision is founded securely on fact.—R. A. Fisher: On the dominance ratio. The "dominance ratio" upon which the relationship correlations depend, when inheritance follows the Mendelian scheme, has a numerical value

for certain human measurements, very near to one-third. This value presents a difficulty to the Mendelian interpretation of the human relationship correlations, in that it could occur only if the frequency ratio of the several factors were unsymmetrically distributed, in such a way that the dominant phase was commonly more numerous than the recessive phase. When, however, the effects of selection are taken into account the distribution of the frequency ratio may be calculated; the distribution obtained is unsymmetrical in the manner required, and the dominance ratio is exactly one-third. The distribution produced by selection also explains the occurrence among the non-recessives of the harmful character sometimes brought out by inbreeding.—A. P. Laurie: Chemical combination and Sir Alfred Ewing's magnetic atom. Sir Alfred Ewing's paper on hysteresis of iron has profound significance for the chemist, for it shows that it is possible to devise an atom of fixed and rotating magnets free from polarity, and that on the approach of another atom the rotating unit can be swung into an unstable position and then fall into a new stable position with evolution of heat. If we assume the electrons to be moving in the tiny orbits but arranged in space round a positive nucleus, the results obtained by Sir Alfred Ewing can be applied to chemical combination, ionisation, and catalytic action.

## Official Publications Received.

Royal Botanic Gardens, Kew. Bulletin of Miscellaneous Information, 1921. Pp. 4+415+42. (London: H.M. Stationery Office.) 10s. net.

Department of the Interior: United States Geological Survey. Water-Supply Paper 487: The Arkansas River Flood of June 3-5, 1921. By R. Follansbee and E. E. Jones. Pp. 44. Water-Supply Paper 477: Surface Water Supply of the United States, 1918. Part 7: Lower Mississippi River Basin. Pp. 38. (Washington: Government Printing Office.)

Memoirs of the Department of Agriculture in India. Botanical Series, Vol. 11, No. 7: Correlation of Colour Characters in Rice. By G. P. Hector. Pp. 153-183. (Calcutta: Thacker, Spink and Co.; London: Thacker and Co.) 1 s. 10 pence; 1s. 8d.

Smithsonian Miscellaneous Collections, Vol. 72, No. 15: Explorations and Field-Work of the Smithsonian Institution in 1921. (Publication 2669.) Pp. 128. (Washington: Smithsonian Institution.)

Survey of India. General Report, 1920-21, from 1st October 1920 to 30th September 1921. Pp. vi+48+8 maps. (Calcutta: Surveyor-General's Office.) 2 rupees; 4s.

Botanical Survey of South Africa. Memoir No. 4: A Guide to Botanical Survey Work. Pp. 89. (Pretoria: Department of Agriculture.) 1s. 6d.

Southern Rhodesia. Geological Survey Bulletin No. 8: (1) The Geology of the Diamond-bearing Gravels of the Somabula Forest, by A. M. Macgregor, with Notes by A. E. V. Zealley; (2) On a Collection of Fossil Plants from Southern Rhodesia, by Dr. A. C. Seward and R. E. Holtum. Pp. 48+12 plates. (Salisbury: Geological Survey.)

Board of Scientific Advice for India. Annual Report for the Year 1920-21. Pp. vii+64. (Calcutta: Government Printing Office.) 12 annas.

National Department of Agriculture for the West Indies. Report on the Agricultural Department, Grenada, January-December 1921. Pp. iv+15. (Barbados.) 6d.

Imperial Department of Agriculture for the West Indies. Report on the Agricultural Department, Montserrat, 1920-21. Pp. iii+33. (Barbados.) 6d.

## Diary of Societies.

## FRIDAY, JULY 14.

INTERNATIONAL NEO-MALTHUSIAN AND BIRTH CONTROL CONFERENCE (at Kingsway Hall, Kingsway, W.C.2), at 10.—Dr. C. K. Millard: Birth Control and the Medical Profession.—Dr. A. Nyström: The Necessity for abolishing Laws against Preventive Measures.—Dr. H. Rohleder: Neo-Malthusianism from the Medical Standpoint.—N. Haire: Sterilisation of the Unit.—Dr. D. B. Hooker: Effect of X-rays upon Reproduction in the Rat.

INTERNATIONAL CONFERENCE OF SETTLEMENTS (at Toynebe Hall, 28 Commercial Street, E.1), at 10 and 2.15.—A. Greenwood, Miss E. M. McDowell, F. J. Marquis, J. J. Mallon, and others: Settlements and Industry.

## SATURDAY, JULY 15.

INTERNATIONAL CONFERENCE OF SETTLEMENTS (at Toynebe Hall, 28 Commercial Street, E.1), at 10.—H. R. Aldridge, T. Adams, Capt. Reiss, Rev. D. MacFadyen, and others: The Relation of Settlements to Health and Housing Reform.

## WEDNESDAY, JULY 19.

FELLOWSHIP OF MEDICINE (at 1 Whipple Street, W.1), at 5.—Y. Bonney: Myomectomy as opposed to Hysterectomy.



# NATURE

A WEEKLY ILLUSTRATED JOURNAL OF SCIENCE.

*"To the solid ground  
Of Nature trusts the mind which builds for aye."*—WORDSWORTH.

No. 2751, Vol. 110]

SATURDAY, JULY 22, 1922

[PRICE ONE SHILLING

Registered as a Newspaper at the General Post Office.]

[All Rights Reserved.]

## BALANCES & WEIGHTS



## REYNOLDS & BRANSON, Ltd.

Chemical and Scientific Instrument Makers to His Majesty's Government (Home and Overseas Dominions).  
LABORATORY FURNISHERS and MANUFACTURING CHEMISTS.

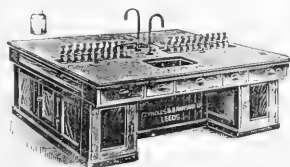

WORKS AND OTHER LABORATORIES equipped with Benches, Fume Chambers, Apparatus, Balances, Chemicals, etc.

Designs and quotations submitted on application

BRITISH - MADE Glass, Porcelain, Nickel Ware, and Filter Papers.

Apparatus in Glass, Metal, or Wood made to customers' own Designs.

CATALOGUES POST FREE.

Enquiries for Technical Chemicals in quantity solicited.

14 COMMERCIAL STREET, LEEDS.



## SPECTROMETERS

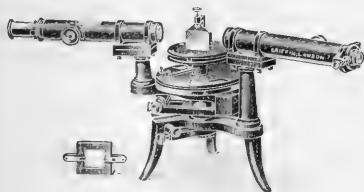

Particulars and Prices on application to—

JOHN J. GRIFFIN & SONS, LTD.  
Kemble Street, Kingsway,  
London, W.C.2.

## HOLIDAY BINOCULARS

We have over 40 different Prism models, and many second-hand patterns in stock. Ask for price list "B.N.," or for a selection on approval.

NEGRETTI & ZAMBRA  
38, HOLBORN VIADUCT E.C.1.  
LONDON.

## THE ROYAL SOCIETY.

### FOULERTON RESEARCH PROFESSORSHIP.

Subject to candidates of sufficient distinction presenting themselves, the President and Council of the Royal Society of London propose to create a FOULERTON RESEARCH PROFESSORSHIP at a stipend of £1400 per annum, the duties of the holder being to conduct such original researches in Medicine or the contributory sciences, on lines approved by the President and Council, as shall be calculated to promote the discovery of the causes of disease and the relief of human suffering. The Professorship will be tenable in the first instance for five years, but may be extended for further periods of five years. Members of either sex are equally eligible.

### FOULERTON RESEARCH STUDENTSHIP.

Subject to candidates of sufficient merit presenting themselves, the President and Council of the Royal Society propose to create a FOULERTON RESEARCH STUDENTSHIP at a stipend of £700 per annum, the duties of the Student being to conduct researches in Medicine or the contributory sciences under the supervision and control of the Managing Committee, to whom he will be required to report from time to time. The Studentship will be tenable for three years, but may be renewed from year to year with a maximum total tenure of six years. Members of either sex are equally eligible. Applications must reach the Royal Society not later than October 31, 1922. Further particulars can be obtained from the ASSISTANT-SECRETARY of the Royal Society, Burlington House, London, W.1.

## ROYAL SCHOOL OF MINES FRECHEVILLE RESEARCH FELLOWSHIPS.

The Imperial College of Science and Technology, South Kensington, London, S.W.7, with which the Royal School of Mines is incorporated, is offering two RESEARCH FELLOWSHIPS of £300 a year each, tenable for one year and possibly renewable for a second year, to aid in carrying out any investigations connected with Mining, Mining Geology, Metallurgy, or the Technology of Oil, which in the opinion of the Selection Committee is of sufficient use or promise.

Applicants, who may be Associates of the Royal School of Mines or others, and preferably men with some practical experience, should apply in writing to the SECRETARY OF THE COLLEGE (from whom further particulars may be obtained) before September 1, 1922, giving the nature of the proposed investigation, qualifications for the work, and references.

It is anticipated that the Committee will make the awards by the end of November, so that the Fellowships and work may begin on January 1, 1923. Holders will be expected to devote their whole time to the work, which may be conducted at the Imperial College or in special circumstances elsewhere at the direction of the Committee.

## ROYAL NAVY.

APPLICATIONS are invited for APPOINTMENTS as INSTRUCTOR LIEUTENANTS in the Royal Navy.

Candidates must be under 30 years of age, have had a University Training, and have taken an Honours Degree in Mathematics, Science or Engineering.

Present rates of pay are at £365 per annum on entry to a maximum of £949 per annum as Instructor Commander.

Promotion, by election, to Instructor Captain is also open, with a maximum of £1277, 10s. per annum.

Retired pay may be granted to Officers over 40 years of age, with a minimum of 12 years' service, up to a maximum of £450 a year for an Instructor Lieutenant Commander, £600 a year for an Instructor Commander, and £900 for an Instructor Captain, according to age and service.

Service vidualling, cabin accommodation, and servant are provided, or allowances in lieu.

An allowance of £50 towards the provision of necessary uniform is payable on satisfactory completion of probationary service.

For further particulars apply in the first instance to the SECRETARY OF THE ADMIRALTY, Whitehall, S.W.1.

## UNIVERSITY OF LONDON, KING'S COLLEGE.

The Delegacy require the services of an ASSISTANT LECTURER in BOTANY (man), one with a knowledge of Physiology preferred; salary, £200 per annum. The duties will commence in October. Opportunities will be given for research work.

Applications, with two copies of not more than three recent testimonials, should be received not later than August 2, by the SECRETARY, King's College, Strand, W.C.2, from whom further particulars may be obtained.

## SUDAN GOVERNMENT.

Applications are invited for the appointment of ASSISTANT GOVERNMENT CHEMIST, SUDAN, at an initial salary of £(E)430, plus £(E)34 temporary war bonus.

Candidates should possess a good chemical degree, and have had experience of Research Work in General or Agricultural Chemistry. Applications, giving particulars as to age, education, scientific training and experience, should be sent before July 31 to Dr. A. F. JOSEPH, 206 Willesden Lane, London, N.W.2, who will arrive in London on July 26. Until that date, further particulars may be obtained from the REGISTRAR, Institute of Chemistry, Russell Square, London, W.C.1.

## UNIVERSITY OF SYDNEY. NEW SOUTH WALES, AUSTRALIA. CHAIR OF ZOOLOGY.

Applications are invited for the above position. Salary (fixed), £1100 per annum, and £150 allowed for travelling expenses to Sydney from Europe. Duties commence March 1, 1923.

Further details of terms of appointment may be obtained from the undersigned, to whom applications (in sextuplicate), stating age and qualifications, accompanied by reference and copies of testimonials, should be sent not later than Thursday, August 31, 1922.

AGENT-GENERAL FOR NEW SOUTH WALES.

Australia House, Strand, London, W.C.2.

July 3, 1922.

## UNIVERSITY OF BIRMINGHAM. FACULTY OF MEDICINE. PROFESSORSHIP OF PATHOLOGY.

The Council of the University invites APPLICATIONS for the CHAIR of PATHOLOGY, vacant by the resignation of Professor SHAW DUNN. The stipend offered is £1200 a year.

Applications (12 copies) may be accompanied by testimonials, references, or other credentials, and should be received by the undersigned, on or before August 7, 1922.

Further particulars may be obtained from

GEO. H. MORLEY, Secretary.

## UNIVERSITY OF ABERDEEN. LECTURESHIP IN BACTERIOLOGY.

Applications are invited for the post of LECTURER in BACTERIOLOGY within the DEPARTMENT OF PATHOLOGY.

Salary, £600 per annum.

Federated Superannuation System for Universities compulsory.

Applications, together with full statement of qualifications, age, and 16 copies of not more than three testimonials, to be lodged before July 31, 1922, with the SECRETARY TO THE UNIVERSITY, MARSHALL COLLEGE, ABERDEEN.

H. J. BUTCHART, Secretary.

## SCIENTIFIC RESEARCH.

THE COUNCIL OF THE BRITISH BOOT, SHOE, AND ALLIED TRADES RESEARCH ASSOCIATION invite applications for the whole-time post of DIRECTOR OF RESEARCH. Salary, £700 per annum, plus superannuation payments. For form of application and particulars apply to THE SECRETARY, Mr. T. A. ROBERTS, Regent House, Kingsway, London, W.C.2.

## WANTED, complete sets or long runs of

"Chemical Abstracts," "Jour. American Chemical Society," "Jour. Industrial and Engineering Chemistry," "Jour. Society of Chemical Industry," "Zeit. f. angewandte Chemie," "Tonindustrie Zeitung." Apply Box 270, c/o NATURE Office.

## THE PROPRIETORS OF THE PATENT

No. 11,818 of 1915, for Improvements in the Electrolytic Refining of Tin, are desirous of entering into arrangements by way of licence and otherwise on reasonable terms for the purpose of exploiting the same and ensuring its full development and practical working in this country. All communications should be addressed in the first instance to: HASELTINE, LAKE & Co., Chartered Patent Agents, 28 SOUTHAMPTON BUILDINGS, CHANCERY LANE, LONDON, W.C.2.

## GREAT MICROSCOPE BARGAIN.

### EXCEPTIONAL OFFER TO STUDENTS.

We offer a few only of the famous Koristka model Da Microscopes absolutely new, and latest models, listed at £27, at the special price of £19. Offer cannot be repeated. Will supply on Deferred terms—£2 down, and twelve instalments of £1:7:6—strict approval, money back if unsatisfactory.

Koristka 1922 Da Microscope, circular stage, centring screws, fine and coarse adjustment, three eyepieces, two dry objectives,  $\frac{2}{3}$ " and  $\frac{1}{2}$ " oil immersion, triple nosepiece, swing-out Abbe condenser, iris, screw adjustment, 60 to 1000 magnifications, in case. Further particulars and illustrated catalogue detailing same, free.

THE CITY SALE & EXCHANGE,  
81 ALDERSGATE STREET, LONDON, E.C.1.



SATURDAY, JULY 22, 1922.

CONTENTS.

	PAGE
The Preservation of Food by Freezing . . . . .	101
The Victorian Age . . . . .	104
Natural History of Pheasants. By W. E. C. . . . .	105
A New Book on the Andamans. (Illustrated.) By R. C. T. . . . .	106
Hydro-Electric Engineering. By F. C. L. . . . .	108
Progress in Fat and Oil Chemistry. By E. F. A. . . . .	109
Our Bookshelf . . . . .	110
Letters to the Editor :—	
Cosmical Theory and Radioactivity.—Prof. J. Joly, F.R.S. . . . .	112
Gas Pressures and the Second Law of Thermodynamics.—R. d'E. Atkinson; Arthur Fairbourne . . . . .	112
Polarisation of Diffused Light under the Sea.—E. E. Brooks . . . . .	114
Discoveries in Tropical Medicine.—Lieut.-Col. A. Alcock, F.R.S. . . . .	114
Ourameba.—G. Lapage . . . . .	114
Histological Stains.—Prof. A. E. Boycott, F.R.S. . . . .	114
The Structure of Organic Crystals. (With diagrams.) By Sir William Bragg, K.B.E., F.R.S. . . . .	115
The Action of Cutting Tools. (Illustrated.) By Prof. E. G. Coker, F.R.S. . . . .	118
The New Building of the National Academy of Sciences, U.S.A. (Illustrated.) By Dr. C. D. Walcott . . . . .	120
The Internal Combustion Engine. By Prof. W. E. Dalby, F.R.S. . . . .	122
The Hull Meeting of the British Association. By T. S. . . . .	124
Current Topics and Events . . . . .	125
Our Astronomical Column . . . . .	127
Research Items . . . . .	128
Glasgow Meeting of the Society of Chemical Industry. By R. M. C. . . . .	130
The Development of Research in Universities. By Principal Irvine, F.R.S. . . . .	131
English Place-Names . . . . .	133
University and Educational Intelligence . . . . .	133
Calendar of Industrial Pioneers . . . . .	134
Societies and Academies . . . . .	134
Official Publications Received . . . . .	135

Editorial and Publishing Offices :

MACMILLAN & CO., LTD.,

ST. MARTIN'S STREET, LONDON, W.C.2.

Advertisements and business letters should be addressed to the Publishers.

Editorial communications to the Editor.

Telegraphic Address: PHUSIS, LONDON.

Telephone Number: GERRARD 8830.

The Preservation of Food by Freezing.

CONSERVATION of our sources of energy is essential to national welfare, and the food-stuffs whence human energy is derived are not the least important of our "fuels." Quite casual enquiry is sufficient to show that serious wastage of food constantly occurs. Markets are at times unable to absorb gluts of fish or fruit for which no cold-storage accommodation is available, and large quantities of these foods are consequently lost, while in the successive stages of transit from the abattoir abroad to the retailer at home, infection by putrefactive bacteria accounts for the loss of an appreciable proportion of our meat supplies. Such losses can be minimised by the development of the methods of cold storage and by a thorough scientific understanding of all that is involved in the refrigeration industry. This industry is now an essential characteristic of life in crowded communities; its expansion during the past forty years, enabling the supply of food to keep pace with the needs of a growing population, has been a remarkable achievement. The importance of the industry is magnified in the case of an island community, such as our own, whose supplies of home-grown food are strictly limited. In an industry of this importance a scientific stocktaking cannot fail to give valuable results.

The refrigeration industry makes wide demands upon the sciences. It calls for the co-operation of physicist, engineer, physiologist, chemist, botanist, zoologist, and mathematician for the solution of its problems. In arranging, through the Food Investigation Board, a joint attack upon the problems of food preservation from these different points of view, the Department of Scientific and Industrial Research is undertaking a most important function. To meet the needs a comprehensive organisation is necessary—if only to visualise the field for research—and since those needs are of vital national importance, it is fitting that the organisation should be initiated and supported by Government.

There has long been lacking a summary of our knowledge concerning the scientific aspects of cold storage, but it has now been supplied by Prof. Walter Stiles, who, at the request of the Food Investigation Board, has prepared a report upon the preservation of food by freezing.<sup>1</sup> We believe that this is the first general systematic study in this country of the scientific principles underlying the preservation of food in the frozen condition. For much of the information which follows we are indebted to Prof. Stiles's report.

<sup>1</sup> "The Preservation of Food by Freezing with Special Reference to Fish and Meat," by Walter Stiles, Special Report No. 7 of the Food Investigation Board. Published by H.M. Stationery Office, 1922, price 10s. net.

Of the two refrigerative processes—chilling and freezing—employed for the preservation of food, the former is much inferior. In this process the temperature is kept at about  $0^{\circ}\text{C}$ ., the physical state of the fresh material being maintained unchanged. In the freezing process, on the other hand, the temperature of storage is kept well below the freezing point of the food substance, which consequently becomes frozen into a solid block, the physical condition being profoundly changed. When it is remembered that, as a rough approximation, the velocity of a chemical reaction is halved by a fall of  $10^{\circ}\text{C}$ ., it will be seen that the chilling process affords greater scope for the progress of the reactions incidental to putrefaction than does the freezing process. Moreover, the solid state of frozen tissue inhibits, or greatly reduces, the growth of micro-organisms and practically puts a stop to such putrefactive chemical actions as take place in aqueous media. While all foods can be preserved for a certain time by the chilling process, comparatively few are at the present time preserved by the freezing process. As Prof. Stiles points out, one of the objects of scientific investigation should be the transference of as many foods as possible from the chilling to the freezing process; and this was the object of many of the experiments of the Food Investigation Board which he describes. His report is restricted to the discussion of the processes and problems involved in the preservation of food in the frozen state. This method of preservation involves freezing, storage in the frozen state, and finally thawing of the frozen material, and the more nearly the condition of the foodstuff so treated resembles the original, the more successful has the storage been from the economic as well as the physiological standpoint.

In the freezing of foods the time of cooling is an all-important matter. It depends upon a number of factors, each of which Prof. Stiles examines in detail and indicates, by reference to the principles of physical chemistry, the extent to which they are controllable in the refrigeration industry. In foodstuffs other than liquids we are dealing with delicate and complex physical systems. True aqueous solutions of organic and inorganic substances and colloidal systems comprising both hydrosols and hydrogels are enmeshed in, or otherwise associated with, more or less definitely solid materials. Foodstuffs comprising such systems are obviously most susceptible to changing physical conditions, and it is only by careful study and control of the latter that successful food preservation can be ensured. The report directs attention to the gaps in our knowledge of matters of fundamental importance in refrigeration, such as, for example, the effect of rate of cooling upon the nature of sols and gels; in some cases the gaps have recently been filled by the work of

Prof. Stiles and his collaborators. Thus he has made the interesting observation that, when rapidly frozen, a chlorophyll hydrosol is reversible; when slowly frozen the hydrosol yields visible "flocks" of chlorophyll, and the sol is not re-formed on thawing. Similarly he finds that the reversibility of the changes taking place in certain gels on freezing is largely dependent upon the rate of cooling, a gel which is rapidly cooled being reversible. Rapid cooling produces a fine-grained frozen mass, and, if this is sufficiently finely grained, the original structure of the sol or gel is restored on thawing. The statement may be extended to the freezing of plant and animal cells and tissues; such information as we have all indicates that, if these be frozen sufficiently rapidly, the changes in structure following freezing are reversed in thawing.

The essential importance of the vitamins for animal nutrition has made it necessary to ascertain the influence of low temperatures upon these accessory food substances. If the influence is markedly destructive, the nutritive value of foods must be seriously depreciated by cold storage. There is very little evidence upon this point at present, but it has been shown by Prof. A. Harden that the vitamin content of butter is undiminished by preservation in this way; investigations of the effect of low temperatures upon the antiscorbutic vitamins are at present in progress. Perhaps of little less importance than the vitamins are the enzymes in foodstuffs. Here more information is to hand. Generally speaking, enzymes survive exposure to the temperatures employed in refrigeration, and can exercise their catalytic functions when temperature and environment again become normal; in some cases, indeed, the catalytic activity may be increased by exposure to low temperatures.

Practically there are only two general methods employed in the freezing of foods on the large scale. These involve freezing in cold air, and in a cold brine solution, respectively.

Prof. Stiles's report includes a comparative account of the principles utilised in these processes. Air cooling is effected either by means of a system of cooling pipes placed inside the refrigerating chamber or by blowing into the chamber air which has been cooled outside by passage over a similar cooling-pipe system. Each method has obvious advantages and disadvantages, and the choice in any particular case will depend upon whether it is more important to reduce desiccation to a minimum or to avoid growth of micro-organisms. Fish depreciates rapidly by desiccation, but is not very liable to attack by micro-organisms; meat, on the other hand, does not lose water readily, but favours the growth of moulds.

The freezing of foodstuffs in salt solutions is a process

still in the experimental stage, although a description of it is to be found in the British patent specification of Hesketh and Marcet of 1899. The advantage of the method over that of air freezing lies in the much more rapid cooling that results, and rapid cooling, as mentioned above, is a characteristic of the most successful refrigeration. Brine is the only salt solution employed in present practice, but other salts, such as magnesium or calcium chloride, might conceivably be used. The process of brine freezing has its inherent difficulties; not only may the food cell contents pass outwards into the cooling medium, but salt may also pass from the latter into the tissues of the food. Penetration of salt into the food material is in some cases (*i.e.* fish) not objectionable, but in certain instances chemical action may occur between the foodstuff and the salt with undesirable consequences. Thus, while large pieces of beef frozen in brine were found to be in some respects superior to air-frozen beef, a reaction takes place between the salt and the pigment of the beef which so changes the appearance of the latter that its market value may be considerably reduced. The penetration of salt into the food substance cannot be prevented, but it can be minimised by a judicious selection of physical conditions.

The methods adopted for the storage of frozen food require the same careful consideration as those employed for freezing; the inherent difficulties are just as great. Physical changes, such as evaporation of water and aromatic flavouring substances, chemical changes including autolytic reactions, hydrolysis of fats and oxidation of the hydrolytic products, and finally the growth of moulds and bacteria, must be guarded against. All these changes can be retarded by lowering the temperature of the storage chambers, but economic conditions impose a limit at which reduction of temperature must stop. It becomes, once more, a question of selecting the least injurious conditions for each particular food; the conditions in storage chambers should, it may be emphasised, be different for different foods.

The use of liquid air on a large scale in the freezing and storage of food appears a remote possibility at the present time; but it is perhaps not entirely fanciful to picture a liquid air plant supplying nitrogen for use in the refrigeration industry and oxygen for other industrial purposes.

Prof. Stiles gives a brief summary of the available information concerning thawing of food. This side of the subject is not without importance, since the rate of thawing of frozen food has a significant effect upon its character.

A considerable proportion of the report is devoted to an examination of the relative merits of air freezing and freezing in salt solution in the case of both fish and

of meat. The comparison, so far as the ultimate value of the food is concerned, is much in favour of the latter process. Parenthetically it may be added that Prof. Stiles does not deal with the economic side of the refrigeration industry. Despite its advantages and the fact that it has been known for a considerable time, the freezing of fish in a solution is a process which has only been employed during recent years, and on a small scale. Its chief advantages are the maintenance of weight, appearance, and general food value of the fish due to the reduced time of freezing and consequent minimised histological change. A quantity of experimental evidence obtained by the author and his co-workers under the Food Investigation Board, as well as by other workers in the subject, is collected in the report, and merits careful study by those who are concerned with the design and installation of food-preservation plant.

For the refrigeration of meat, freezing by immersion in brine has not yet been technically employed; the only process utilised is that of freezing in cold air. Beef which has been preserved in the frozen state is frequently inferior to fresh beef on account of the drip of meat juice which occurs on thawing. This loss may amount to as much as 15 per cent. of the weight of the meat. Consequently beef is, wherever possible, transported in the chilled condition; but since it cannot be kept in this state for more than three or four weeks, it is not possible to import chilled beef into the United Kingdom from Australia or New Zealand. From far distant countries beef must come "on the hoof" or in the frozen condition. Mutton, on the other hand, can be imported in the frozen state from the countries named in perfectly satisfactory condition. The discovery of a method of freezing beef which will obviate the difficulties mentioned is evidently a matter of importance, and the attempts made by the Food Investigation Board in this direction are of considerable interest. Small preliminary experiments indicated that rapid freezing by immersion in cold brine was an effective way of preservation so far as absence of drip, and appearance and flavour of the product after thawing were concerned. Larger-scale experiments have not yet gone sufficiently far to yield conclusive results. One rather serious objection has already been mentioned. This is the discoloration of the surface layers of the lean of the meat owing to the conversion of hemoglobin into methæmoglobin. The discoloration detracts seriously from the appearance and market value of the meat, but it is hoped that the cause, and a method of prevention, will be discovered in the course of further work. The successful application to beef of the method of brine freezing would lead to a very desirable expansion of our source of supply.

### The Victorian Age.

*The Victorian Age: The Rede Lecture for 1922.* By Dr. William Ralph Inge. Pp. 54. (Cambridge: At the University Press, 1922.) 2s. 6d. net.

IN choosing the Victorian Age as the subject of his Rede Lecture, Dean Inge afforded his audience ample occasion in which to enjoy the *obiter dicta*, which so frequently characterise his public utterances, and impart to them so piquant a flavour. It may be said the theme itself provided its opportunities. Its possibilities, in fact, of observations *en passant*, without a too obvious breach of continuity, are well-nigh limitless. The learned lecturer evidently revelled in the wealth and suggestiveness of his material, and the epigrams and aphorisms, at times, are almost coruscant in their brilliancy. Not that we would for a moment imply that the Dean's prelection in any way resembles the sermon of which King James remarked "that the tropes and metaphors of the speaker were like the brilliant wild flowers in a field of corn, very pretty, but which did very much hurt the corn." The richness of the soil which the Dean undertook to cultivate ensured the wealth and vigour of his crop; his flowers do but enhance the beauty of the field.

It may, however, be questioned whether the Dean's *obiter dicta* are always as sound as they are brilliant. For example, it is by no means invariably true that the pioneer starts by being unintelligible or absurd, has then a brief spell of popularity, and ends by being conventional and antiquated. The general character of the Civil Service in 1837 no doubt left much to be desired, but it is a travesty to say that it was "a sanctuary of aristocratic jobbery," and that its clerks were languid gentlemen with long whiskers, who, like Charles Lamb, departed early from their offices because they arrived late. The Dean occasionally is in danger of risking his credit for veracity by his irrepressible lore of paradox and his affection for the epigram's peculiar grace, and for

"Some unexpected and some biting thought

With poignant wit and sharp expression fraught."

If, however, we make due allowance for the characteristic foibles of the lecturer, the Dean's brilliant survey of the significant features of the time covered by the reign of Queen Victoria is both illuminating and instructive. As he truly says, that period extended over the latter half of a *saeculum mirabile*, the most wonderful century in human history. His word-picture of England before what Toynbee styled the Industrial Revolution, is done in his most characteristic manner. The country then, we are told, was, on the

whole, prosperous and contented. "The masses had no voice in the government, but most of them had a stake in the country. . . . Political power was in the hands of a genuine aristocracy, who did more to deserve their privileges than any other aristocracy of modern times. . . . They were enlightened patrons of literature and art, and made the collections of masterpieces which were the pride of England and which are now being dispersed to the winds. . . . Those who have studied the family portraits in a great house, or the wonderful portrait gallery in the Provost's Lodge at Eton, will see on the faces not only the pride and self-satisfaction of a privileged class, but the power to lead the nation, whether in the arts of war or of peace"—a picture, in short, which will bring solace to the shade of that "Great Cham of Literature," the immortal Dr. Samuel Johnson. Not that the Dean can be truthfully described as a *laudator temporis acti*, for he is never wholly content with any age, and least of all with that in which he lives.

The whole account of the condition of England in the earlier years of the Victorian Age is tinged with that flavour of mordant pessimism in which the Dean delights, and practically every phase and institution of the period comes under the gentle lash of his tolerant satire—its literature of complacency, the Platonism of Ruskin, the vehemence of Carlyle, the ugliness of the modern English or American town ("Never since civilisation began has such ugliness been created"); the gigantic blunder of the Industrial Revolution; the problem of mending or ending industrialism, foolishly called capitalism. ("Ruskin's own artistic life would have been impossible without the paternal sherry and the rich men who drank it; and Morris's exquisite manufactures depended absolutely on the patronage of the capitalists whom he denounced.") Departmental inefficiency; the systems of judicature; the slow emergence of the universities from the lethargy of the eighteenth century, "when they neither taught nor examined nor maintained discipline," when the Fellows "were most of them waiting for college livings, to which they were allowed to carry off, as a solatium, some dozens of College port"; the state of the army, "when a Royal Duke could not be given a military funeral, because there were not troops enough to bury a Field Marshal"; its glaring incompetence as revealed by the Crimean War, etc.

But the age had its compensations. The Dean is constrained to admit with Lecky that, at least so far as internal affairs went, no country was ever better governed than England between 1832 and 1867. "The one prime necessity for good government was

present; those who paid the taxes were also those who imposed them. . . . Sound finance benefited the whole population by keeping credit high, interest low, and taxation light. Political life was purer than it had been, and purer probably than it is now. The House of Commons enjoyed that immense prestige which has been completely lost since the old Queen's death."

With regard to the intellectual and spiritual movements of her reign the Dean, if not exactly eulogistic, is at least more commendatory, and no part of his lecture affords more delightful reading, or exhibits sounder discrimination, than his account of the literary glories of the Victorian Age. As regards religion, he thinks it may be doubted whether organised Christianity has ever been more influential in England than during that period, "before the growth of the towns threw all the Church's machinery out of gear." At the same time, he admits that religious intolerance was very bitter, and only the secular arm stopped a whole series of ecclesiastical prosecutions. "Real hatred was shown against the scientific leaders, which Darwin calmly ignored, and Huxley returned with interest."

In parting with his subject the Dean, as might be anticipated, strikes no jubilant note. To him the Elizabethan and the Victorian Age appear as the twin peaks of English civilisation. But, he concludes, "as regards the fortunes of this country, the signs are that our work on a grand scale, with the whole world as our stage, is probably nearing its end." To which we can only fervently reply, *Absit omen*.

### Natural History of Pheasants.

*A Monograph of the Pheasants.* By William Beebe. In four volumes. Volume III. Pp. xvi+204+pl. XLV-LXVIII+photogravure plates 40-60. (London: published under the auspices of the New York Zoological Society by H. F. and G. Witherby, 1922.) 12l. 10s. net.

THE third volume of this sumptuous work treats of the true pheasants—the genus *Phasianus*—and of the birds of the allied genera *Puchrasia*, *Catreus*, and *Syrmaticus*. Mr. Beebe has made an extensive study of the genus *Phasianus*, which embraces the most familiar and important birds dealt with in the monograph. His conclusions, based upon an exhaustive examination of numerous specimens, and his unique knowledge of the birds in their native haunts, are of outstanding importance.

In order to treat clearly of the group, Mr. Beebe has drawn a sharp line of demarcation between *Phasiani*

as they exist in their real zone of distribution, and the forms which have been crossed indiscriminately and acclimatised in all parts of the world. At least thirty-five forms have been described as species, or sub-species, or geographical races, according to the personal bias of authors; but in the evolution of these forms, mutation appears to have played little part, for most of them actually grade into one another, and even in their extremes are separated only by slight differences of colour and pattern. A good deal of individual variation occurs, especially in the more widely distributed forms, and this necessitates changing the status of species in this genus. The genus has usually included more forms than those recognised by the author, who, by consistently applying his criterion of genera—that of geographic non-overlapping—has removed the birds of the genera *Syrmaticus* and *Calophasis* from *Phasianus*, which is thus left "as an exceedingly homogeneous group."

In addition to a careful comparison of the numerous types and study of their environment, distribution, and barriers, Mr. Beebe has devoted much attention to the classification of the birds of this genus. Two very different lines of observation have contributed much to his ultimate decision. First, the results of a single day's collecting in China revealed, out of four brace of fully adult birds in freshly moulted plumage, several belonging to one covey, three recognisable sub-species, and two undescribed ones were obtained in two moderate-sized rice-fields. The second array of facts is derived from the conditions found among semi-wild hybrids introduced into foreign countries. Thus, at Tring, pheasants of *colchicus*, *torquatus*, and even of *versicolor* blood were turned down. Later a strain of *pallasi* was introduced, and from this mixture there arose pheasants which were absolutely indistinguishable from the wild form known as *satscheuensis*, the home of which is in the heart of China. From scores of similar facts Mr. Beebe has decided to consider every one of the continental forms of *Phasianus* as sub-species of *Phasianus colchicus*. The Japanese pheasant (*P. versicolor*) stands the test of a good species and is the most distinct of all the *Phasianus* group.

The distribution of the wild members of the *colchicus* group extends across Asia, from the Sea of Azof and the Black Sea eastwards to the Sea of Japan—a distance of nearly 5000 miles—and from Manchuria in the north to beyond the Tropic of Cancer. Throughout this wide area they have penetrated into valleys or along mountain slopes, sweeping through passes and adapting themselves to semi-arid deserts.

The typical form of the entire group, the common pheasant, the "Rion Caucasian Pheasant" of the

monograph, is a native of Caucasia, and is said to have been introduced into Europe from the banks of the River Phasis (now the Rion) in Colchis (now Kurtaisi). Though not mentioned by Mr. Beebe, the remains of Phasianus have been found in the Miocene of France and Switzerland, in the Pliocene of Greece, and in the Pleistocene of Germany—hence pheasants, possibly forms of colchicus, existed in Europe long before the advent of man.

With regard to the Koklass pheasants—genus Puchrasia—Mr. Beebe alludes to the difficulty of placing them with certainty in any linear scheme of classification. They show traces of resemblance to several groups, and perhaps come as close to the genus Syrmaticus, as defined by him, as to any other. The genus is one of the most interesting of the Phasianinæ, and its various forms reveal one of the rarest phenomena in nature—a widespread series showing delicately graduated and increasing complexity within a single closely related group of living creatures. Three species are recognised—*P. macrolopha*, *P. xanthospila*, and *P. darwini*, each with several forms.

The genus Syrmaticus, previous to Mr. Beebe's researches, contained a single species only—the gorgeous long-tailed Reeves pheasant, but here it has been expanded to include four additional species, namely, the copper pheasant, *S. soemmerringi*, comprising three forms; Hume's pheasants, *S. humia*, with two forms; Elliott's pheasant, *S. ellioti*; and the Mikado pheasant, *S. mikado*.

The Cheer pheasant (*C. wallichii*) exhibits a number of characters sufficiently distinct to warrant its inclusion in a separate genus, *Catreus*. It is confined to a comparatively small belt in the west and central Himalayas—Kumaon, Garhwal, and western Nepal—where it is found at elevations of 4000-10,000 feet.

In addition to the author's masterly treatment of the taxonomic aspect of the subject, he has added a charm to it by his graphic descriptions of the haunts and habits of the various birds which came under notice during his remarkable journeys, undertaken for observing and procuring specimens in various stages of plumage. He has also quoted copiously, when desirable, from the experiences of others. This combination of excellence, if it has ever been equalled, has never been surpassed in such a monograph.

The coloured plates, twenty-four in number, are reproductions from original drawings. Of these eleven are devoted to the principal forms of the true pheasants, and are from very careful drawings by the late Major Jones. The rest are the work of several well-known artists, among them Mr. G. E. Lodge, Mr. Fuertes, and Mr. Grönvold, but their reproduction is not so satisfactory as those which graced the pre-

ceding volumes. There are twenty-one photogravure plates depicting the haunts amid which the various forms are found and some of their nests. These are mainly from photographs by Mr. Beebe, and add much to the attractiveness of the volume. The maps delineating the distribution of all the forms treated of are a very useful adjunct.

W. E. C.

### A New Book on the Andamans.

*The Andaman Islanders: A Study in Social Anthropology.* (Anthony Wilkin Studentship Research, 1906.) By A. R. Brown. Pp. xiv + 504 + 20 plates + 2 maps. (Cambridge: At the University Press, 1922.) 40s. net.

THIS handsome volume contains the anthropological results of a short residence of about eighteen months in the Andaman Islands on behalf of the "Anthony Wilkin Students' Research," and may therefore be taken as a sample of approved work by the modern type of Cambridge-trained student. It is well produced by the Cambridge University Press, and is excellently illustrated from photographs taken, it is presumed, by the author. Indeed, so good are these last that the present writer recognises the originals of several of the portraits. As regards photographs illustrating these aborigines, their surroundings, habits, manners, and customs, the scientific world is specially well off, owing to the efforts extended over many years by such competent illustrators as Messrs. E. H. Man and M. V. Portman, the many magnificent volumes of the latter observer, deposited in the India Office Library, being not nearly so well known as they should be.

The book may be divided into two parts: a running account of Mr. A. R. Brown's travels, giving the results of his observations of facts, together with references to and criticisms of his predecessors in this particular field of research, chiefly of Mr. E. H. Man, and an "interpretation" of the observations. The plan of the book is thus a good one. The writer states his own observations and where he differs from his predecessors, and then builds his theories on the results. It is where he ventures to differ from Mr. Man that the plan seems to fail to be as effective as it ought to be. He constantly sets up Mr. Man's views and statements only to knock them down. He thus pits his opinions against Mr. Man's. This makes for comparison, and leads to the observation that Mr. Man was thirty years with the Andamanese, knew them intimately and their language well, and studied them unremittingly: all this, too, at a time when they were numerous, their tribes well separable from each other, and the contact



with Europeans comparatively recent. Whereas Mr. Brown was with them for a short time, depended on interpreters, did not know the language except superficially, and only met them after they had been so decimated by epidemics that the tribes had had to drop their old exclusiveness and mingle freely together. It is true that Mr. Man was a pioneer who had to learn

nothing more than a witness—a good witness certainly, trained to his work—but only a witness, and the reader will have to decide for himself between him and Mr. Man.

In the matter of recording language Mr. Brown has not been fortunate, though he has laboured hard. The older books and articles, from Mr. Man's works

onwards, used an alphabet framed *ad hoc* by no less an authority than the late Mr. A. J. Ellis, whose skill, knowledge, and experience in such matters are still difficult to beat. The result has been that a good trustworthy system for recording these "unwritten" dialects for English readers has been in vogue for something like half a century. Mr. Brown has discarded it, and substituted the "Anthropos" Alphabet of Pater Schmidt. No one disputes the capacity of Pater Schmidt in this matter, but why in a book by an Englishman for English readers, published by an English University, go to an Austrian for the transcription of the language of the inhabitants of a British possession, when an adequate and well-known English transcription has been established for a long period, and has been used in many books? At any rate the result is not happy. Diacritical marks are used which are strange to English readers, though common enough in the Eastern European languages. The vowels are not familiar to users of English, and what are we to say of an observer who cannot detect the difference between "the *e* in error" and "a in Mary," and thinks they represent the same sound (p. 496). Or between the "o in not" and the "o in nought" (p. 496). Unhappily for Mr. Brown all four sounds are common in Andamanese, and he has



An Andaman Islander shooting fish in Port Blair Harbour  
From "The Andaman Islanders."

his way, and that Mr. Brown was a trained observer from the beginning, but all who know Mr. Man's work cannot also help knowing how meticulously and conscientiously careful he is in recording an observation of fact. It requires some boldness to differ from him on the point of accuracy. Several observers have tried, and not successfully. The result is that this latest book on the Andamanese after all contains only evidence and not judgment. Mr. Brown is, here,

thus put himself out of court as a recorder of languages, much more so as a critic of other people's work in this respect.

Like so many of his Oxford and Cambridge contemporaries, Mr. Brown reverts too often to a bad habit of the seventeenth-century writers on travel and foreign countries in ignoring the bibliography of his subject—in this case a long one—except to appropriate without acknowledgment the information gathered,

often laboriously, by even living predecessors. There are too many clear instances of this in his book.

Despite its drawbacks, however, the book supplies much good evidence on its subject, and the student will do well to make its acquaintance. With the second part one is not inclined to quarrel. It propounds a theory which cannot be gone into in a short review; but whether a theory stands criticism or not as time goes on, it is a good thing to put it forward, as the mere dissection of it promotes research and the acquisition of knowledge resulting from the research.

R. C. T.

### Hydro-Electric Engineering.

*Hydro-Electric Engineering.* Vol. 1, *Civil and Mechanical.* Editor: Dr. A. H. Gibson. Contributors: H. D. Cook and the Editor. Pp. x+232. (London: Blackie and Son, Ltd., 1921.) 25s. net.

THE water resources of the world, from the point of view of available power for domestic, industrial, and agricultural uses, have received very considerable attention in recent years, and in many countries a large amount of information has been accumulated as to the amount of water-power that is available for exploitation. Not only have various sources of power, such as those of the great waterfalls, been harnessed, but in addition many schemes for impounding waters in suitable valleys and utilising them for power generation, irrigation, and for distribution to cities many miles distant have been carried into effect and at the present time many more are receiving serious consideration. In this country much has been done to impound waters for town and city purposes, but comparatively little has been attempted to develop the water-power available. Until the war came, with all its consequent economic problems, not least of which is the very serious increase in the price of coal, power could be produced by steam-engines and internal combustion engines at a price which made it practically impossible for water-power to compete, involving as it does large capital outlays per unit power produced and cost of transit over long distances. It is perhaps not surprising, therefore, that although Fairbairn and James Thompson in the British Isles were largely responsible for the very important developments which took place in water wheels and turbines in the nineteenth century, and the correct principles of design were very largely developed here and in France, yet neither of these countries have developed water-power as have, for example, Switzerland, Norway, and the United States. Students in Great Britain have not been encouraged to take a very keen interest in the subject and the

literature published in this country has been somewhat scanty.

Recently, however, the Water Resources Committee, which has issued a number of reports, has investigated the power available in Great Britain, and a good deal of interest has been aroused in the possibilities of the development of hydro-electric power schemes. An equal interest has been awakened in other parts of the empire where the power available is much greater than here and where coal is not so easily obtained. This work on hydro-electric engineering comes, therefore, at an opportune time, for it is desirable that engineers and business men should understand clearly the principles underlying the storage and use of water for power purposes, and engineering students should have available a trustworthy guide in the study of the subject. A word of warning is required to those who hope to take a short cut to knowledge of the subject. In few branches of engineering have such diverse matters to be dealt with, and thus only those who are prepared by a sound training in engineering principles, civil, mechanical, and electrical, can appreciate fully and overcome the difficulties.

In the work before us, the authors have discussed some of the important principles involved but a great part of the work is occupied with descriptions and details of actual works. The all-important subject of the relationship of the water available to the rainfall on a given watershed, the power that can be obtained, and the problem of the flow of water and its measurement receive adequate treatment in the first third of the book.

The remaining portion of the book deals entirely with turbines. The various types are described with the aid of drawings of actual turbines, and the principles of design are discussed. It is of the greatest importance that the behaviour of turbines under variable conditions of gate opening and speed should be known, and typical characteristic curves are given for reaction turbines in which unit power is plotted against unit speed for various gate openings. Efficiency curves are also shown for turbines working under varying conditions of load. The Pelton Wheel is described and the theory discussed. The all-important question of the choice of the most suitable type of turbine for particular conditions is somewhat briefly referred to but the essential points to be considered are clearly presented.

An important chapter is devoted to speed regulation, and hydraulic problems connected with any attempt to change suddenly the flow of a large volume of water, and the theory of the surge tank are clearly discussed. Johnson's approximate formula for the movement of the water in a large tank for a given change of velocity

in the pipe is also obtained. The danger of the period of oscillation in the tank synchronising with the governor is pointed out, and Johnson's differential surge tank, introduced to overcome this difficulty, is described. The concluding chapters deal with the general arrangement of stations and water-power reports. The text is clearly written and the illustrations are very good.

F. C. L.

### Progress in Fat and Oil Chemistry.

*Chemical Technology and Analysis of Oils, Fats and Waxes.* By Dr. J. Lewkowitsch. Sixth edition, entirely revised by G. H. Warburton. Vol. 1. Pp. xviii + 682. Vol. 2. Pp. xii + 959. (London: Macmillan and Co., Ltd., 1922). 36s. and 42s. net.

THE successive editions of Lewkowitsch's "Oils and Fats"—now carried on by his successor, Mr. G. H. Warburton—are regarded almost as milestones by those engaged, in whatever capacity, in the industries based on these products, and their appearance affords a fitting moment for taking stock. It is perhaps of interest that the third edition was noticed in NATURE of September 22, 1904, p. 502, the fourth in the issue for August 19, 1909, p. 211, and the fifth in the issue for December 18, 1913, p. 449. The book is now of such size that this—the sixth edition—is like its predecessor, divided into three volumes of which only the first two have so far appeared. The index, unfortunately for the reader and the reviewer, is confined to the third volume, so that reference to these volumes is far from easy. We would strongly urge that this defect in so valuable a work be rectified in the future, as the temporary use of the first two volumes is impaired, and the reader in the future has to go to the labour of consulting two heavy volumes for the desired information.

Volume 1 as heretofore is devoted to the chemistry and analysis of the fats, a side which during the last decade has been relatively neglected. Volume 2, after an all too brief introductory section devoted to the obtaining of oils by the various methods of practice, deals in detail with the properties of the several oils. Volume 1 is described on the title page as entirely rewritten and enlarged, and volume 2, more circumspcctly, as entirely revised. Both volumes, however, would be more properly described as revised, as little more has been done than to bring them up-to-date by the addition of new matter. No doubt in the remaining volume, which deals with a section of the subject in which very great progress has been made largely as the result of the altered conditions brought about by the war, much will have to be rewritten, but it is scarcely correct to apply this phrase to these volumes.

From this point of view the new edition is frankly a disappointment: opportunity might have been taken to prune much which was diffuse and indefinite, and really to keep the work up-to-date in a crisp form. As it is, the reader at all versed in the subject will more often than not experience disappointment on consulting it, while for those who have the former edition the expenditure of a somewhat large sum on the new issue cannot be justified.

It is to be regretted that the study of the chemistry of fats and allied compounds is not at present fashionable amongst schools of chemical research, possibly in part because of the difficulty of the subject and the need to tackle it by what may be termed team work before results can be obtained. However this may be, the field of research is full of the most interesting possibilities both in the domain of pure organic, of physical and of biological chemistry. We may cite the work of Hardy, Adam, Langmuir, and others in this connexion, and the pioneer work on the synthesis of mixed glycerides commenced by Emil Fischer just before his death, with the hope that some of our workers will once more be attracted into this field of inquiry. Analytical work such as is embodied in volume 2 of the book is of interest technically, but the number of oils of prime industrial importance is limited to those which can be produced in quantity, and with sufficient regularity to make it an economical proposition to instal the requisite machinery to deal with them. Consequently, but few of the newer oils described become of practical interest: the world shortage of oils and fats so confidently predicted by the expert a few years ago has failed to materialise, so that there is no demand for new oils; indeed, to-day most of the vegetable oils are being marketed at prices unremunerative to the grower and manufacturer.

What is mainly wanted at the present time is far greater attention to quality: in this connexion it should be emphasised how little is known as to the manner of production of oils in plants, and the supposed change in the proportion of saturated to unsaturated acids in the oil during the ripening of the seed; also the cause of the development of fatty acid in the oil and its increase during storage. There is an opportunity for much research on the part of the biochemist in this direction.

The structure of a long open chain organic compound and the points of weakness at which it is most susceptible to attack is a question of prime interest to the chemist. The close packing hypothesis of Pope and Barlow, the modern crystal structure theory of the Braggs, and the recurrent spiral structure resembling a drawn-out coil of wire attributed to it of others, all have their adherents, and additional practical data are

most desirable. The hydrocarbons themselves are unsuitable for this purpose, but the fatty acids with their crystalline derivatives afford much more desirable material for research.

While in no way depreciating the enormous amount of information contained in the book, which virtually makes it an exhaustive dictionary, it is permissible to suggest that from the point of view of the user, a much more careful selection and limitation of the material would be an advantage. E. F. A.

### Our Bookshelf.

*Die chemische Analyse.* Herausgegeben von Dr. B. M. Margoschke. VIII.-IX. Band: Methoden zur Untersuchung von Milch und Molkereiprodukten. Von Dr. Kurt Teichert. Pp. 374. (Stuttgart: F. Enke, 1909.) 11.40 marks (England: 45.60 marks).

ON account of the interest now being shown in the quality of our milk supply, attention may be usefully directed to this book. It deals exclusively with milk and dairy products and forms the eighth and ninth volume of the general treatise on chemical analysis. The greater part of the space is devoted to the standard methods of analysis, but there is in addition a large amount of information which ought to be of help to the analyst and medical officer of health.

A preliminary section deals with the composition and properties of milk and the factors which are responsible for any change in the normal composition. Following this comes the portion which is concerned with the detailed analytical methods for the determination of fat, milk sugar, protein, etc. The chapter on cleanliness of milk and its freedom from bacterial contamination puts the facts in a clear and convincing manner, and is very valuable in view of the recognition of the dangers of uncleanness both from the standpoint of public health and the manufacture of such products as butter and cheese. In this connexion the employment of the reductase and catalase tests has not become so general as was at one time expected, although the direct determination of dirt is now a regular practice in all analytical and public health laboratories, and leads to the punishment of those who dispose of filthy and insanitary milk.

Purely bacteriological methods of examination are shown to be difficult, particularly when applied to the detection of pathogenic organisms. The fermentation test, which is easily and rapidly carried out, is now being used to a greater extent both in connexion with the public milk supply and the cheese factory.

The chapter on the adulteration of milk, and the interpretation of the results of analysis obtained in this connexion, is valuable, as is also the one on the testing of cream, skim milk, whey, condensed milk, etc.

As in the case of milk, so with butter and cheese there are given details of analytical methods and hints on the interpretation of results. The detection of adulteration by the addition of foreign fats is dealt with, and other sections are concerned with the analysis of materials used in the preparation of cheese.

The volume is one for reference and the details appear to be scientifically sound.

*Aeroplane Performance Calculations.* By Harris Booth. (The Directly-Useful Technical Series.) Pp. xv + 207. (London: Chapman and Hall, Ltd., 1921.) 21s. net.

THE development of aviation appears to be entering on a new phase in which "safety in the air" is singled out as of primary present importance. This follows an era of military devotion to the cult of "performance," and the object of the book under review appears to be the statement of the detailed steps which have hitherto been taken to secure the greatest speed and maximum rate of climb of an aeroplane.

It is probable that the actual arithmetical processes described will rapidly fall out of use, but that the principles invoked will have a greater degree of permanence. The interest of the book is not so much in the relative merits of the four methods of prediction of aeroplane performance described in chapter 11, as in the statement of the problem as it appears to a designer. Much of the book shows the individuality of the author, but the general outlook is typically that of the community of aeroplane designers.

It is perhaps desirable at this point to indicate the established position as to aeroplane design and its relation to performance. The data used by all are common—derived mainly from sources external to the aviation industry—and have been used with almost equal success by a number of designers. In the result it is found possible to predict the consequences of the best efforts from preliminary sketch designs. To realise completely the maximum performance, it is necessary for a designer to consider the details of his craft carefully, and Mr. Harris Booth's book shows how that may be done. Further, it illustrates an essential element of progress, for it assesses in numerical form the importance of separate items in the complete whole. In illustration of this point, it will be found that 14 lbs. is estimated to be the resistance of a flying-boat hull if the open cockpits and hydroplaning steps are excluded. A further estimate shows that the steps account for 52 lbs. at the same speed and each cockpit for a further 17 lbs. Here is a striking example of the fact that the very small resistance of a smooth streamline body may be increased five- or six-fold by departures required for various reasons.

It is just because of its indications of the need for care in design that the present volume may fairly be accorded a place on the shelves of an aeronautical or design office library. So far as can be judged its importance is limited to such function, since the writer is following common practice in supposing that "performance" does not include "safety."

*Building Contracts: The Principles and Practice of their Administration.* By Edwin J. Evans. (The Directly-Useful Technical Series.) Pp. xviii + 304. (London: Chapman and Hall, Ltd., 1922.) 10s. 6d. net.

THE building trade resembles a good many others in that, while liberally supplied with works on the technical side, there is very little literature dealing with the business side. The present volume is intended to fill this gap. The subject matter is divided into four

parts, namely, the administration of contracts, office management, book-keeping, and trade memoranda. A glance at the table of contents will prepare the reader for some interesting information regarding what goes on behind the scenes. For example, among "methods usually adopted by contractors to obtain business" we find the following which refers to work undertaken on a percentage basis:—"It is surprising how many commissions of this character are secured by some contractors, and often well proceeded with, before their competitors are aware that the work is in operation. It must therefore be obvious that a good portion of the time and energy of these enterprising contractors is spent by keeping in touch with and studying the wishes and the requirements of architects and others who have work to place. These contractors are usually most obliging and amiable gentlemen who see no trouble in doing anything which will bring about business." The author is equally candid in many other matters, and it is impossible to read his book without feeling that he is intimately in touch with all the ramifications of his subject. The volume is a mine of information on all matters connected with the execution of building contracts, and will be of great value both to contractors and students.

*Handboek der Algemeene Erfelijkheidsleer.* By Dr. M. J. Sirks. Pp. x+494. ('S-Gravenhage: M. Nijhoff, 1922.) 15 gld.

TEXT-BOOKS of genetics have lately appeared with great rapidity. The most recent is that by Dr. Sirks, now before us. It is a substantial and well-illustrated volume, as good as its predecessors, covering the ground which has been explored up to date. The weakness of the book is that it attempts nothing new, whether by way of presentation or analysis. In a subject so new as genetics, something more than an exposition of easily accessible records should be demanded from a considerable text-book. The literature of horticulture and of animal breeding contains abundant material, both illustrative of established principles and suggestive of extensions, which has not yet been drawn upon. An author need be at no loss for novel themes of discussion, even if he has no actual discovery to present.

Dr. Sirks shows a disposition to limit his survey to the publications of the modern period and to subjects which have acquired topical familiarity. His treatment, moreover, is occasionally uncritical. The reader should have been told more explicitly that some of the interpretations, given as accepted doctrine, are highly speculative, and that some of the statements of fact are greatly in need of verification. Reports, for example, of the production of mutations as a direct consequence of changed conditions should not be accepted without a warning that, until the experiments have been repeated on an ample scale and confirmation obtained, evidence of this class has only suggestive value.

*Manchester University Roll of Service.* Pp. xvi+274. (Manchester: At the University Press; London: Longmans, Green and Co., 1922.) 10s. net.

THE Roll of Service of the University of Manchester contains 3765 names, of which 500 are those who lost their lives on service during the war. In each of these

latter cases a brief account is given of the career, including details of parentage, education, military history, distinctions, and particulars of death. In all, 842 distinctions were won, including two Victoria Crosses.

A preface to the volume has been written by the Vice-Chancellor, Sir Henry A. Miers. The record is very well arranged and produced, and serves as an adequate reminder of the service rendered by members of the University. It is also, to some extent, a memorial to those who laid down their lives in the common cause.

*James Stirling: A Sketch of his Life and Works, along with his Scientific Correspondence.* By Charles Tweedie. Pp. xii+213. (Oxford: Clarendon Press, 1922.) 16s. net.

MR. TWEEDIE'S volume opens with an account of the life of James Stirling, the distinguished mathematician of the early eighteenth century. Next follows a description of Stirling's contributions to mathematical knowledge, chief among them being his enumeration of cubic curves and the *Methodus Differentialis*. This latter is a remarkable piece of analysis, considering the state of mathematical knowledge at the time when it was evolved; it leads to the well-known expansion for  $\log(n!)$  associated with Stirling's name. About three-quarters of the volume is occupied by copies of letters exchanged (during the period 1719-1740) between Stirling and such contemporary mathematicians as Maclaurin, Cramer, N. Bernoulli, Machin, Clairaut, and Euler. In days before scientific journals were developed new results were communicated by one worker to another in such letters as these. Much care has been expended by Mr. Tweedie in the reproduction of these letters: his book would have been improved by the addition of English translations of the French and Latin ones and by further comments upon them.

W. E. H. B.

*Contemporary Science.* Edited, with an Introduction, by W. B. Harrow. (The Modern Library of the World's Best Books.) Pp. 253. (New York: Boni and Liveright, 1921.) 95 cents net.

THE work under notice consists of a collection of twelve essays on recent achievements in various branches of science, by men who are masters in each. All are written in a way which makes them intelligible to readers whose special knowledge is not profound; yet even those who are engaged in advanced research may find interest in perusing them. This applies with special force to an excellent review of modern physics by Prof. Millikan. Though perhaps none the worse for the fact, the volume is a little unbalanced, articles of general importance being placed side by side with those dealing with such special topics as methods of gas warfare, the physiology of the aviator, and the measurement of brain-power. The inclusion of these is a reflection of the preoccupations of war time; and if their interest has waned, they serve to mark points in history. Atomic structure, engineering (Parsons), enzymes (Lister), duration of life, bacteriology (Flexner), psychoanalysis and Einstein, will serve as clues to the scope of the volume.

### Letters to the Editor.

[The Editor does not hold himself responsible for opinions expressed by his correspondents. Neither can he undertake to return, or to correspond with the writers of, rejected manuscripts intended for this or any other part of NATURE. No notice is taken of anonymous communications.]

#### Cosmical Theory and Radioactivity.

SIR ERNEST RUTHERFORD in his book "Radioactive Substances and their Radiations" has suggested the possibility that solar heat may be supplied from radioactive energy derived from elements which had become radioactive under the extreme thermal conditions prevailing.

(As possibly having bearings on cosmical theory (formation of nebulae, planetary genesis, etc.) I would direct attention to the probability that such induced radioactivity would be attended with explosive phenomena on a very great scale and of extreme intensity.)

Let it be assumed that in some deep-seated region of the sun the temperature has attained a potential critical for some element present—that is to say, adequate to disturb the atomic stability of this element. Now normal radioactivity results from internal atomic causes and the radioactive constant is statistical in origin, like a death-rate. But here instability is induced from without inwards. It seems, therefore, difficult to imagine that a normal radioactive constant can control the resultant effects. What will happen must resemble no mere death-rate based on statistics, but rather the mortality brought about by earthquake or flood. A large number of the specific atoms would be affected and a very great local rise in temperature would follow. There is, now, the further probability that this sudden rise will involve yet other elements in the catastrophe.

If this inference is justified, explosive phenomena in suns and nebulae so far from being unaccountable must be regarded as inevitable, as being associated with gravitative attraction and the internal properties of the atom.

It is to be expected that such explosive phenomena would diminish in frequency and intensity as time advanced and elements of higher atomic weight became degraded. Thus, in primeval times, our sun may have been many times rent by such explosions. There appears to be evidence that central explosions of great violence occasionally occur even to-day.

How would the principle of the conservation of moment of momentum fare under conditions involving the translation of internal atomic energy into molar forms?

J. JOLY.

Trinity College, Dublin, July 9.

#### Gas Pressures and the Second Law of Thermodynamics.

IN the June *Philosophical Magazine* Mr. Fairbourn endeavours to prove that in certain easily attainable cases the second law of thermodynamics might be circumvented. He attempts to show that if an enclosure be divided by a partition, the chance that a molecule of a rarefied gas will pass the partition, from the space I to the space II, may be modified, by a funnel, without affecting the chance of passing from II to I, so that a pressure difference will arise. He considers the simple case, shown in Fig. 1, of a right-angled "funnel" in two dimensions only, truncated so that the diameter at the end BC is twice that at AD. Taking a point O on BC he shows

that, of the molecules passing through O, on the whole more than half will be reflected by AB or CD and less than half will pass through AD, since they can approach from an angle  $\pi$  while the angle between the limiting paths by which they can get through is in general less than  $\pi/2$ . He deduces that of  $2N$  molecules striking BC in a given time less than  $N$  will pass through AD, while all of the  $N$  molecules reaching AD from the other side in the same time will cross it, so that on the whole more will come from II to I than *vice versa*.

The error in this argument lies in the fact that it is impossible to construct a line BC out of a number of points O; it is necessary to define the tolerance before one can say whether molecules have passed through O or not. As soon as this is done (by taking an element of length  $dl$  at O, and defining passage through O as passage through this length), it is clear that the chance of "passing through O" is not independent of the angle of incidence  $\theta$ , but is proportional to  $\cos \theta$ , since  $dl$  is foreshortened for obliquely moving molecules. In any given case it will now be found that the total number of paths leading through AD is the same on both sides of the partition ZZ'. However, the following general proof of this equality should save the trouble of integrating particular cases. It applies to three dimensions and any shape of funnel.

It is clear that before the funnel (AB,DC) was added to the partition the chances of passing from

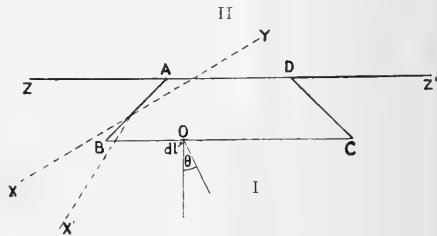

FIG. 1.

II to I and from I to II were equal, and that adding the funnel does not alter the chance of passing from II to I. If it is to have an effect then it must decrease the number of paths from I to II. But for every such path XY which it blocks it introduces a new path X'Y, and this is true of every point in any funnel. This result is of course well known in geometrical optics; if it were incorrect any temperature and energy density of radiation would be obtainable without work.

It may also be remarked that there is not only molecular roughness in even a polished wall, but thermal agitation of all the molecules of the wall; the argument that if the wall reflects light it should "reflect" a molecule is vitiated by the fact that the wave-length of visible light is about a thousand molecular diameters; and the argument that even if the direction of rebound is fortuitous the funnel should have an effect defies elementary hydrostatic theory.

Lastly, the mean free path of the molecules is irrelevant. Mr. Fairbourn assumes that his theory would not apply if there were a large proportion of encounters between gaseous molecules; but it is clear that if the effect of the funnel is to give on the whole a bias away from II to the average molecule striking it, it cannot matter whether that molecule retains the bias or hands it on to another in an encounter.

The effect, if there were one, should be proportional to the number of molecules striking the funnel per second, *i.e.* to the total pressure.

R. D'E. ATKINSON.

Clarendon Laboratory, Oxford, June 1.

In reply to Mr. R. d'E. Atkinson's letter, I should like to point out that, while his conclusion is undoubtedly true with regard to light, it is by no means clear that analogy justifies his extension of this conclusion to the molecular problem under consideration in my paper. The fundamental conception of unchanging uniform concentration would appear incorrect when applied to particles proceeding between collision centres and entering a minute vessel, the diameter of which is considerably less than the mean free path of the gas concerned. This confusion of issue, introduced by regarding the problem of light as identical with that I was considering, may perhaps be brought out most clearly by the following calculation, which is almost identical with the one Mr. Atkinson suggests would be possible.

If ABCD (Fig. 1) is the figure dealt with in the paper, and DH, AF, PE all be inclined at angle  $\alpha$  to BC, while DI is perpendicular to BC, and D' is the

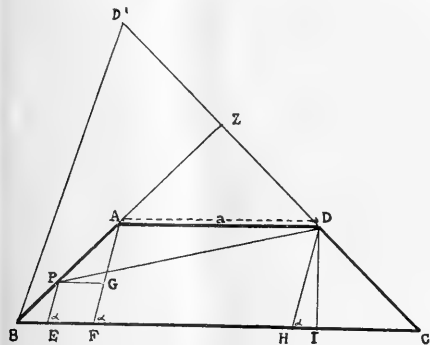

FIG. 1.

mirrored image of D with respect to BZ, P being the point on BZ such that angle EPB is equal to angle DPA, then the following relationships may be calculated.

Case 1, where  $\alpha$  is not less than angle D'BC. By the usual laws of reflection, light approaching BC from below, approximately at angle  $\alpha$ , must pass out at AD if it enters between E and H, but will be returned through BC if it enters either between B and E or between H and C.

$$EH = EF + FH = PG + a = a \cot \alpha + a.$$

Case 2, where  $\alpha$  is not less than angle DBC, and is not more than angle D'BC. In this case only light entering between B and H will escape through AD.

$$BH = BI - HI = \frac{3}{2}a - \frac{a/2}{\tan \alpha} = a(1\frac{1}{2} - \frac{1}{2} \cot \alpha).$$

Case 3, where  $\alpha$  is less than angle DBC. In this case all the light will necessarily be returned through BC. Where  $\alpha$  is greater than a right angle these three cases are merely duplicated.

Hence, if equal light intensity in all directions be assumed, and if A be taken as a constant representing its uniform concentration, then the ratio of the

amount of light which passes from AD to BC to that which passes from BC to AD in unit time must be

$$\begin{aligned} & A \int_{\alpha=0^\circ}^{\alpha=90^\circ} a \sin \alpha \cdot d\alpha \\ & : \left\{ A \int_{\alpha=\angle D'BC}^{\alpha=90^\circ} (a + a \cot \alpha) \sin \alpha \cdot d\alpha + A \int_{\alpha=\angle DBC}^{\alpha=\angle D'BC} a(1\frac{1}{2} - \frac{1}{2} \cot \alpha) \sin \alpha \cdot d\alpha \right\} \\ & = Aa : \left\{ Aa \int_{\alpha=\angle D'BC}^{\alpha=90^\circ} (\sin \alpha + \cos \alpha) d\alpha + Aa \int_{\alpha=\angle DBC}^{\alpha=\angle D'BC} (1\frac{1}{2} \sin \alpha - \frac{1}{2} \cos \alpha) d\alpha \right\} \\ & = Aa : Aa (0.643 + 0.357), \text{ approximately,} \\ & = Aa : Aa. \end{aligned}$$

The above integration to equality is essentially dependent upon the axiomatic acceptance of the unchanging existence of equal concentrations or

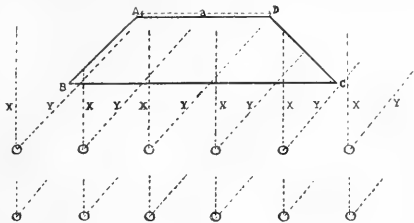

FIG. 2.

intensities in all directions, uniformly throughout the medium in which the cone is placed. Such unchanging uniformity of concentration might be presumed to exist in perfectly diffused light, but it cannot exist in gases, since changes of concentration occur as intermolecular collisions, and must be important in relation to the entering of vessels considerably smaller than the mean free path of the gas. The light problem is one of flow; the molecular problem may be regarded as one of (interrupted) oscillation, at least to a large extent.

If each of the little circles in Fig. 2 be taken to represent equal areas (or spheres if three dimensions are being considered), the probability of molecules proceeding outwards, from collision in one of these circles, along a path X, is equal to that of their proceeding from collision, in that same or any other equal circle, along a path Y, this being true however many circles are under consideration, even in the limit of their occupying the whole space within free path distances from the cone. If two directions, X and Y, are considered for a large number of such circles, regularly placed so as to be representative of the equal probability of collision in all parts, it is obvious that molecules approaching BC along directions X

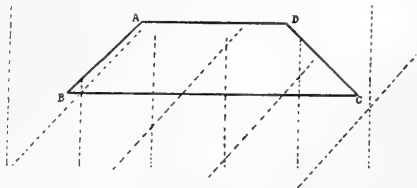

FIG. 3.

and Y, and starting from collision sources, do not cross BC in numbers proportional to the sines of the angles of these paths with BC, as has to be assumed in light calculations such as the one above, which may be illustrated by Fig. 3 where no collisions occur,

and where the light approaches in two regular streams of equal concentration. The difference is due to the position of the opening BC relative to collision centres below it within less than free path distances, from which the approaching molecules will start, with equal probability of movement in all directions. The molecular problem would thus appear to approximate to the simple statement in my paper, in which the "points O" may consequently be regarded as little elements of area, and to be quite different from light calculations such as the one worked out above.

In connexion with Mr. Atkinson's claim that elementary principles would be defied if an effect were to occur, it is not obvious why this should be so (provided, as has always been emphasised, that the apparatus shall be sufficiently small to deal with the oscillations or movements of molecules individually), any more than in the case of the energy of a swinging pendulum being converted into useful external work by the agency of suitable mechanism.

The argument that if light is reflected, then molecules must actually be so similarly, to which Mr. Atkinson strongly objects, does not appear in my paper, where, in fact, the exact opposite is stated (page 1053, line 26), although such reflection, as an average effect, is not regarded as being impossible.

ARTHUR FAIRBOURNE.

King's College, University of London,  
Strand, W.C.2, June 22.

#### Polarisation of Diffused Light under the Sea.

I took advantage of a recent opportunity to make some observations on polarisation of the diffused light in sea-water, using a detector consisting of four quartz prisms made up on the De Senarmont principle, combined with a Nicol. The depth was 30 feet, the sea-water very clear, and the day cloudy, with no trace of sky polarisation. The diffused light at the bottom was quite strongly polarised, the water behaving like a turbid medium observed at right angles to the incident beam, the plane of polarisation being perpendicular to the surface.

The greatest intensity was in the horizontal direction, diminishing rapidly as the angle of elevation increased, and disappearing completely long before the direction became nearly vertical. Repeated observations created a strong impression that the direction of maximum polarisation was not exactly horizontal, but very slightly inclined downwards. However, the difference, if any, was so small that it must be regarded as doubtful.

I should have liked to repeat observations on a day of blue sky, but the opportunity did not arise. The light from the sandy bottom and from a white plate did not show any trace of polarisation.

Apart from polarisation, it was interesting to observe the surface. It is not easy to look vertically upwards in a diver's helmet, but there was evidently a circular luminous area directly overhead, rapidly falling off in intensity without any sharpness of transition. It was a kind of inverse penumbra effect.

E. E. BROOKS.

Leicester City Technical School, June 30, 1922.

#### Discoveries in Tropical Medicine.

IN NATURE of June 24 Sir Ray Lankester repeats his statement that the transmission of *Filaria bancrofti* from infected to healthy men through the intermediation of the mosquito is not a sufficiently established fact. I trust you will permit me to state, for the benefit of those of your readers who may be puzzled by an assertion so discordant with current teaching, that at this school we shall always be happy to demonstrate sections of mosquitoes and of human

lymphatic gland that show the facts of that transmission.

With regard to Sir Ray Lankester's other emphasised statement that "Manson did not discover the part played by the mosquito" in this transmission, we shall be happy to show Manson's original charts and drawings made in Amoy, and other necessary evidence that Manson did follow out the development of the embryonic and larval *Filaria bancrofti* in the stomach and body-cavity of the mosquito. This evidence, quite apart from any additions to it or corrected inferences from it, establishes the essential fact that the insect is the vital agent of transmission, since it releases the imprisoned embryo from the blood-vessels of its host, nourishes it until certain necessary organs are developed, and thus enables it to make a start in life.

A. ALCOCK.

London School of Tropical Medicine,  
Emsleigh Gardens, Euston Road, N.W.1,  
July 5.

#### Ouramœba.

WITH regard to the notes by Messrs. Rowley and Kirkpatrick in NATURE of July 8, on the occurrence of Leidy's genus *Ouramœba* in England, it may be of interest to record that I have recently (a few days before their letters were published) found one specimen of *Amœba proteus* in this condition, *i.e.* infected with a parasitic alga. I was very much interested, because I have never encountered anything like *Ouramœba* in the neighbourhood of Manchester, where I have chiefly collected.

I have not Leidy's book with me now for reference, but am familiar with his figures, and have no doubt whatever that the specimen which I found corresponds exactly with his genus *Ouramœba*. It was a typical *Amœba proteus*, with filaments of the parasitic alga projecting fanwise in two tufts, one tuft on each side, nearer the end which was posterior in progression. Its vitality certainly was not impaired in any way.

This specimen was taken from a small tarn near Crag House farm, not far from Windermere. The tarn lies at the summit of a ridge, the altitude of which is given as 700 feet on the Ordnance Survey map. It should be emphasised that, although the tarn contains ordinary *Amœba proteus* in fair abundance, only one specimen has so far been seen which was infected with the alga. The other fauna of the tarn include very numerous *Thecamœbida*, some *Flagellata*, *Ciliata*, *desmids*, *diatoms*, etc., a fauna which corresponds fairly closely with that dealt with by Leidy in his book, and which is probably typical of open moorland country at high altitudes.

*Amœba proteus* is found in other tarns in this neighbourhood; but I have never seen any other specimen infected with the alga from these other localities, although, since reading Mr. Rowley's letter, I have again searched fresh material.

G. LAPAGE.

Bowness-on-Windermere, July 10.

#### Histological Stains.

WITH reference to Dr. Nierenstein's remark (July 8, p. 33) that the British dye industry would do well to pay attention to the supply of dyes suitable for histological work, it should be recorded that in 1919, when pathologists here had a difficulty in getting satisfactory stains, the Pathological Society of Great Britain and Ireland approached Dr. Levinstein in the matter and received from his organisation ample and most useful help which carried us on until reasonably good stains became available again through the ordinary trade channels.

A. E. BOYCOTT.

July 8.



## The Structure of Organic Crystals.<sup>1</sup>

By SIR WILLIAM BRAGG, K.B.E., F.R.S.

IT may be said with truth that modern advances in physical science are due in the main to the acquisition of the power to handle the individual atom. Until the present time we have always attacked the problems of matter by examining the behaviour of atoms or molecules in groups. The new powers arise in two ways:—

In the first the individual atom is endowed with excessive speed and energy, and is able to make its individuality felt on this account. The  $\alpha$ -particle of the radioactive radiations is a helium atom moving with a speed of the order of one-tenth of that of light. While in possession of the relatively tremendous energy which the speed implies it can, unaided, make a visible impression on a fluorescent screen. It can pass through thousands of other atoms without sensible deviation and, if occasionally it suffers violent deflection, it has penetrated to the very core of the atom which has deflected it. Rutherford has shown us what important deductions can be drawn as to the construction of the atom by examining these rare and sharp deviations, and is going even further in examining the shattering effect which the deflecting atom may itself experience. So also, the electron endowed with sufficient speed can traverse matter and bring about its ionisation and other effects of great interest, but if its velocity becomes less than one million metres per second this free existence disappears. It is attached to the first atom it meets.

The second method of attack upon the individual atom proceeds on very different lines. It is by way of the mutual action of X-rays and crystals. When we are examining things by eyesight we follow the influence of the objects that we look at upon the waves of light. If we wish to penetrate deeper into the minute, we take advantage of the optical effects of lenses and build microscopes: but, even then we cannot attack individual objects containing less than many thousands of individual atoms. A limit is set by the difficulty that light cannot show us the form of things which are much smaller than the wave length of the light itself. With the aid of the very short waves known as X-rays we can make our way down to objects ten thousand times smaller, but by itself this extension of our powers would be inefficient, because the effect due to one atom or one unit of pattern would be inappreciable. Here lies the value of the crystal, which, being an aggregate of some small atomic pattern repeated again and again through space, shows up on a measurable scale the properties of the atoms in the single unit. By the combination of X-ray and crystal we can examine the very foundations of material construction. It is difficult to set a limit to what may be the consequences of the exercise of these powers since we can now examine all physical effects, so to speak, at their source, and must in the end be able to refer all the physical and chemical properties of materials to the properties of the individual atoms and their mutual forces. So far the new methods have scarcely begun to show their full strength. A few inorganic crystals have been examined with a view of discovering

their structure, but the new field of research is barely entered. Inviting roads lie before us pointing in numerous directions.

Very little has yet been done in the way of applying the new methods to the structure of organic crystals, although no study could be more tempting. Their vast variety of form, the perfection of their structure, their importance, all urge us forward, and especially the fact that the whole progress of organic chemistry shows that the science depends upon laws of position with which the X-rays are especially qualified to deal. The difficulty at the outset lies in the complexity. In the naphthalene molecule there are 18 atoms: in what way can we expect by means of X-rays to solve the intricate problem of their relative positions? Our first attempts to solve inorganic crystals depended for their success upon two facts:—

The first, the simplicity of the structures which were attacked.

The second, the guidance derived from the principles of crystallographic symmetry.

The determination of the structure of rocksalt opened a way to further determinations of such simple crystals as the diamond, zinc blende, fluorspar, and others. In all these the principles of symmetry supplemented the knowledge derived from the examination of the intensities of X-ray reflection by the various crystal planes. As the work has proceeded in the hands of observers in many countries, other principles have emerged or are emerging which render further and very valuable aid so that problems appear to be coming within our grasp that not long ago seemed most difficult of solution.

Of these principles, one began to appear in consequence of the very earliest results. It was a very striking fact that in crystals of polar substances the molecule seemed to disappear; it was in fact dissociated, and the structure of the crystal depended upon the grouping of the positive ions round the negative and of the negative ions round the positive. In rocksalt each metal atom is surrounded by six atoms of chlorine and *vice versa*. If we accept this as an indication of the general character of such structures, adding to it the condition that every atom is to be like every other atom of its own kind in respect to relative distances and orientations of all its neighbours, it becomes possible to foretell the probable form of structure, using the X-ray methods for subsequent verification. This method of proceeding may be very much easier than if it were taken in the reverse way. We might for example have gone far to foretell the structure of fluorspar. It is an ionic compound in which the calcium atoms are doubly charged and fluorines are singly charged. Each positive is to be surrounded, therefore, by twice as many neighbours as each negative by positive. The fluorspar structure in which the metal atoms are arranged at the corners and the face centres of the cube, while the fluorines lie at the centres of the eight small cubes into which the larger ones can be divided is one of the very few regular ways in which this numerical relation of 2 to 1 can be carried out. So also in ice, the 2 to 1 arrangement is

<sup>1</sup> Discourse delivered at the Royal Institution on Friday, May 19.

carried out in a second of these ways, the relative numbers of neighbours being four to two. It is the lightest and most open of the 2 to 1 structures, and is consistent with the low specific gravity of ice and with the possibility of compressing the substance into denser forms: at the same time it shows the six-pointed arrangement and the featheriness of the snow crystal.<sup>2</sup>

The earlier results at the same time showed that in the diamond we had a construction of very different properties and nature. Here the atoms are electrically neutral and are bound to one another, not by electrical attraction from centre to centre, but by a more intimate process which probably consists in some way of a sharing of structural electrons. The diamond is on this account the hardest of known substances.

These considerations amount to a recognition that the bonds between the atoms may be of very different characters though it may be difficult to draw hard and fast lines between them. We can say that there is a very strong electron sharing bond of which the diamond is typical, and that there are ionic bonds in polar compounds which in general are of a weaker character, as, for example, in rocksalt, though on the other hand they may be strong when, as in the ruby, the ionic charges are large.

Lastly, there is a third type, which is found in the organic crystal, where it would appear that the separate molecule can be distinguished. The atoms in each molecule are strongly tied together, but the forces that bind molecule to molecule may be described as residual. They would appear to be weak fields concentrated at definite points on the molecule, the positive and negative charges to which they are due lying within it.

The second principle which emerged fairly early in the experiments was described by my son in an address which he gave in this Institution some time ago.<sup>3</sup> We may call it the principle of radii of combination. The distance between the centre of one atom and the centre of a neighbour can in many cases be measured with great accuracy: we can compare these distances when substitutions are made in isomorphous compounds. The replacement of fluorine by chlorine, chlorine by bromine, bromine by iodine in a series of salts produces changes in the distances which imply that the radius of any one of the atoms mentioned may be treated as a constant within the range of the substitution considered. The accuracy is amply sufficient to give useful assistance in crystal analysis. It would not be true, however, to say that each atom has an invariable radius, and indeed the original statement of the principle purposely refrained from going so far. It is not right to speak of the *radius* of an atom; it is better to speak of a *radius of combination*. We may take an illustration from the behaviour of arsenic, antimony, and bismuth. The crystals of these substances are trigonal in form,<sup>4</sup> plainly showing that the properties of each atom are not the same in all directions within the crystal: in fact, analysis shows that each atom is fastened to three on one side of it by much closer bonds than to three atoms on the other side. One bonding resembles more closely that of the diamond, the other

that of a metal where free electrons keep the atoms together by electrostatic attraction. It may be said that the atom behaves as a metal on one side and a non-metal on the other. At any rate, there are two radii of combination varying with the nature of the bond. The metallic bond is the weak one and the cleavage plane cuts only through such bonds. It seems very likely that in this way we can understand the formation of crystals of different type when these elements enter into their composition. For example, in the cubic form of senarmonite ( $Sb_2O_3$ ) the atoms of antimony are completely separated; each touches six atoms of oxygen, while each oxygen touches four atoms of antimony. Antimony is here behaving as a metal only, so that we represent it in a model as a sphere, and the uniform spheres of antimony and of oxygen naturally build into a simple crystal. It is a cube in which the atoms of antimony occupy the corners and centres of the faces while the six oxygen atoms lie at the centres of six of the eight small cubes into which the large one can be divided.

There is, however, an alternative form of  $Sb_2O_3$  known as valentinite, which is ortho-rhombic. Analysis, so far as it has gone, though it is not yet complete, points emphatically to the conclusion that here atoms of antimony are pairing, the bonds between the members of a pair being of the stronger variety already referred to. We now have an elementary body of a dumb-bell shape which, when forming part of the crystal structure, will naturally cause a deviation from a simple cube.

Yet again, there are principles which are barely established as yet, though it seems probable that they will be found of material assistance in analysis. The greater expansion of some crystals in certain directions than in others seems to depend upon the nature of the bonds. Bismuth expands more along the axis than across it, as we might expect from the fact that in the one expansion the weak bonds alone can be operative. In the same way diamond has an extremely small expansion co-efficient because all the bonds are of the strongest kind, but in graphite, on the other hand, the expansion along the axis may be described as enormous. Mr. Backhurst finds an increase in length of 3 per cent. for a rise of 900° C. At the same time, so far as can be inferred, the expansion across the axis is still quite small. In one case weak bonds only are concerned, in the other, strong bonds of the same kind as in the diamond.

It is when all these considerations are taken into account that it seems possible to make an attempt upon the structure of the organic crystals. They are, of course, very complex; naphthalene contains 10 atoms of carbon and 8 atoms of hydrogen, and our ability to interpret X-ray evidence, that is to say, the relative intensities of reflection by the different planes in different orders, is not sufficiently advanced to enable us to place so many atoms in their proper position in the cell from this evidence alone. We can readily find the size of the unit cell, show that there are two molecules in it, and that the points, each of which represents a whole molecule, are to be placed as is shown in Fig. 1, but without some further help we can frame no hypothesis on which to proceed.

Suppose now that we compare the structures of diamond and graphite. As my son showed long ago,

<sup>2</sup> Proc. Phys. Soc., London, vol. xxxiv, pt. 3, p. 98.

<sup>3</sup> See *Phil. Mag.*, Aug. 1920.

<sup>4</sup> James and Tunstall, *Phil. Mag.*, Aug. 1920 and July 1921; Ogg, *Phil. Mag.*, July 1921.

the structure of graphite must be derivable from that of the diamond by separating to nearly double their previous distance the sheets of atoms parallel to one of the cleavage planes of the latter crystal. The question has been very carefully considered more recently by Hull in America and by Debye and Scherrer on the Continent in the hope of finding more exactly the details of the movement: they do not quite agree.

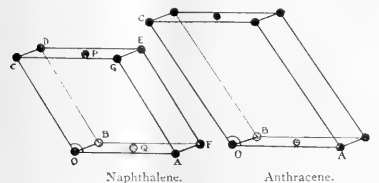

FIG. 1.—Unit cells of naphthalene and anthracene drawn to the same scale.

	OA = a.	OB = b.	OC = c.
Naphthalene	8.34	6.05	5.69
Anthracene	8.7	6.1	11.6
Naphthalene	$\alpha = \text{BOC} = 90^\circ$ , $\beta = \text{COA} = 122^\circ 49'$ , $\gamma = \text{AOB} = 90^\circ$ .		
Anthracene	$\alpha = \text{BOC} = 90^\circ$ , $\beta = \text{COA} = 124^\circ 24'$ , $\gamma = \text{AOB} = 90^\circ$ .		

Fig. 2 represents the change as described by Hull. The bonds between the atoms in each sheet are unaffected apparently, but those between sheet and sheet are replaced by something much weaker. The diamond is typical of hardness, the graphite is used as a lubricant. If the hexagonal rings of which the sheets are formed have survived this violent change, why not suppose that they may survive the further change when the sheets break up into ring structures? In other words, suppose that the benzene ring is really a fact, not merely a diagram; the distance between atom and atom in

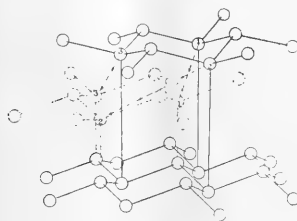

FIG. 2.—The fine lines of the diagram show the structure of graphite. By moving the top layer to the position shown by the broken lines the diamond structure is obtained.

the ring is 1.54 Å.U. as in the diamond, and perhaps we may add that the atoms are not all in one plane, but are arranged, as may be seen in Fig. 3. We then proceed to test this hypothesis by finding whether we can fit together molecules of the assumed size and shape into the cells which hold them. From X-ray studies we know the exact form and dimensions of the cells, and can learn also much concerning the relative distributions of the molecules within them. It appears at once that in the few simple cases which have been examined an excellent fit is possible and, more than that, we find encouraging signs that the structural idea has been chosen rightly. For instance, the comparison of the cells of naphthalene and anthracene, one a two-ring, the other a three-ring combination,

shows that two of the axes of the cell remain constant while the third has grown by an amount which is nearly the width of the benzene ring. From these and various other indications we build a structure such as is represented in Figs. 3 and 4. It would seem that the molecules are linked together side to side more strongly than from end to end, and that is why these and similar crystals cleave across the end or  $\beta$  position.

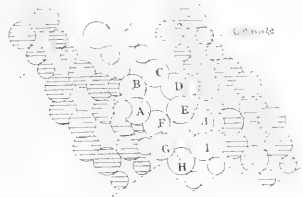

FIG. 3.—Showing mutual relations of three naphthalene molecules and parts of others.

The unshaded circles between the two cleavage planes represent a molecule as at Q (Fig. 1). The shaded represent molecules B and F in the same figure. The small circles represent hydrogen atoms, but their size is uncertain.

Diameter of carbon atom = 1.50, BH = 4.92. Projection of AD on the plane of the diagram = 2.50. Benzene ring consists of atoms A...F only.

If we examine  $\alpha$ -naphthol in which hydrogen at the side of the naphthalene molecule has been replaced by an OH group, we find that the standard cell contains four molecules, which is what we should expect, for each of the four  $\alpha$  positions must be represented. When the OH group is taken from the side and put at the end, we find that the cell has shrunk sideways and grown lengthways by the amount we should expect to result from the addition of an oxygen atom. When as in acenaphthene a complex group of atoms is attached to one side of the molecule and the crystal

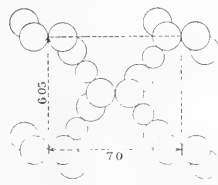

FIG. 4.—Section of naphthalene cell perpendicular to the axis of  $c$ , showing  $\alpha$ -hydrogens connecting the molecules side to side.

to our surprise becomes more regular than before, right angled instead of oblique, we find an explanation in the fact that there are now four molecules within the cell instead of two, and that by sloping in pairs in opposite ways they increase the symmetry of the crystal.

These examples may serve to show how an attempt may be made to arrive at a knowledge of the structure of these organic compounds with, I think, some success. It seems justifiable to see in the rigid and queerly shaped molecule attaching itself at definite points, and with great precision of orientation to neighbouring molecules, a cause of the immense multiplicity and, at the same time, the accurate form of organic crystals, and indeed to find here the foundations of organic chemistry.

## The Action of Cutting Tools.

By Prof. E. G. COKER, F.R.S.

ENGINEERING activity is so largely dependent on the action of cutting tools, that it is not surprising to find a very large amount of research work has been devoted to its study, and at the present time there are in England two committees actively pursuing researches in this field, in addition to private investigators. At the suggestion of the Cutting Tools Research Com-

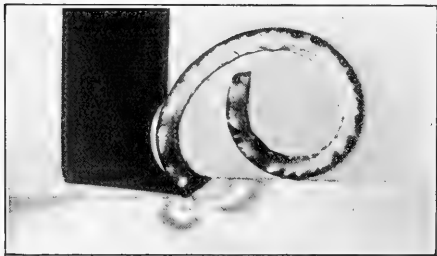

FIG. 1.—Steel tool planing a strip of nitro-cellulose.

mittee of the Institution of Mechanical Engineers, of which Sir John Dewrance is chairman, some experimental studies of a preliminary character have been made recently at University College, London, on transparent bodies subjected to the action of cutting tools, and the double refraction produced by stress has been used to measure the stress distribution in the cut material. Similar experiments have also been carried out on some glass-cutting tools used for turning and planing operations.

The photo-elastic method has many advantages over direct experiment on metals, as up to and, in fact, well beyond the elastic limit of the transparent nitro-cellulose used, the stress distribution produced can be measured with considerable accuracy at all points in a disk or flat plate under the action of a tool. The optical effects give, at once, a measure of the difference of the principal stresses at a point, the lateral contractions afford a measure of their sum, and the isoclinic lines map out the directions of the stresses. Existing literature shows how very difficult it is to obtain similar information from the metal itself when under the action of a tool. Since the distributions are similar up to the elastic limit of each material, owing to the absence of elastic constants in the fundamental equation  $\nabla^2 \chi = 0$ , there are obvious advantages in a study of the characteristics of cutting tools by these means. The general phenomena observed when a tool is cutting are shown in Fig. 1, where a steel tool is planing a plate of nitro-cellulose in a circularly polarised field of light. It will be observed that colour bands spring from the cutting edge of the tool and curve round in approximately circular arcs to meet the boundary, indicating the existence of variable radial compression stress in

the area in front of the tool, and a similar state of tensional stress behind it.<sup>1</sup> Measurements of the principal stresses and their inclinations show that this is approximately what obtains, and a very fair idea of the stress conditions in the material can be obtained from the photograph if radial lines are drawn in all directions from the point of the tool to intersect the colour bands. The outer bands pass through all points at which the stress is 1150 pounds per square inch, for the sharply defined boundary between the purple and the blue, and the succeeding ones reckoning inwardly mark stresses of twice and three times this value. The fourth band indicates possibly a somewhat different stress intensity than its numerical order warrants, owing to its close proximity to the black area in which intense plastic stress is developed at and near the cutting edge of the tool. An interesting feature is the partial recovery of the material, for the black area is met with only at this place. The shaving again shows brilliant colour effects after it has finally left the tool, but later becomes obscured, again owing to the further curl developed due to contact with the parent material.

Careful measurements show, however, that the actual state of stress, excluding the plastic field, is somewhat more complicated. The stress is never quite radial, and the isoclinics are therefore not straight lines, but are always curved somewhat, as indicated in Fig. 2, which shows a set of isoclinics obtained from a disk of about six inches in diameter when subjected to the action of a turning tool with a somewhat acute cutting angle. The lines of principal stress confirm this, and the values of the minor principal stresses appear to be small in the cases examined so far, and to a first approximation the distribution of principal

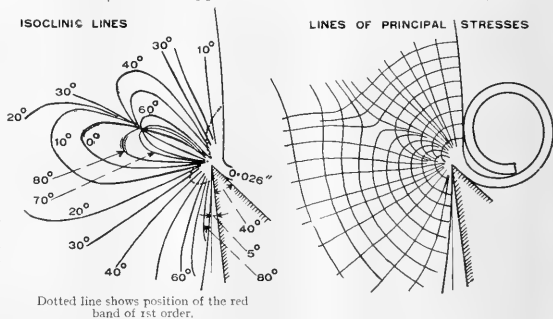

FIG. 2.—Isoclinics and lines of principal stress in a disk under the action of an edge-turning tool. From the Proceedings of the Institution of Mechanical Engineers, by permission of the Council.

stresses  $\bar{R}\bar{R}$  and  $\bar{\theta}\bar{\theta}$  may be taken to be of the type

$$\bar{R}\bar{R} = (-2P/\pi) \cdot \cos \theta/r$$

where  $\bar{\theta}\bar{\theta}$  is small, and the angles are measured from the radial black brush dividing the tension from the compression area. The position of this latter brush

<sup>1</sup> "An Account of some Experiments on the Action of Cutting Tools," by Prof. E. G. Coker and Dr. K. C. Chakko, Proceedings of the Institution of Mechanical Engineers, 1922.

depends on the cutting angle of the tool, and also upon its rake and clearance, but investigation has not proceeded far enough as yet to define accurately the influence which each element has upon its position.

A somewhat remarkable change from these conditions is produced when the cutting edge is not so perfectly sharp as it is possible to make it. It then becomes apparent that the shaving is no longer cut from the main body, but is broken or torn away by the continual forcing of a wedge between the shaving and the main body of the material, after the latter has once been penetrated. The shaving breaks away at a point A above the cutting edge (Fig. 3), mainly owing to the

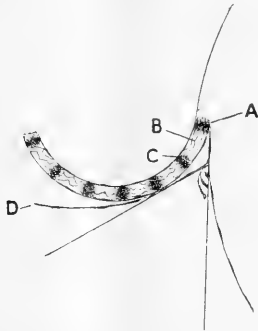

FIG. 3.

bending action exerted by the raking face of the tool, and is so much overstressed at this place that all colour effects are obliterated. An intense and permanent black patch is therefore produced separated by a less stressed part B, in which plastic stress colour effects are observable from a similarly much more overstressed part C immediately preceding. These effects are repeated at regular intervals as is indicated in Fig. 3 in a somewhat diagrammatic form, and are accompanied by a rhythmic pulsation of the colour bands in phase with this phenomenon. The tearing away of the shaving in this manner produces a rough uneven surface on the material, which in planed work is therefore not truly flat, and in turned work is not perfectly cylindrical. It is probable that this influences the character and kind of chip produced in brittle materials, as it undoubtedly influences the shaving from an elastic material which is capable of assuming a plastic condition. Moreover, it is sometimes found that when this latter condition occurs the tool is acting in a two-fold capacity, for not only does it break off a shaving, but it may also pare off the irregularities as the point of the tool comes in contact with them, so that occasionally a second and much thinner shaving, D, is produced, and peeled off as indicated in Fig. 3, by a true secondary cutting action. Double shavings are sometimes produced in this manner when steel is turned in a lathe, and it is probable that the fine powder, which can often be observed falling away from a tool working on cast iron, is due to this secondary cutting action.

In tools with multiple cutting edges the same general features of stress distribution are observed in the

material. They are sometimes accompanied by additional phenomena, as, for example, with the milling

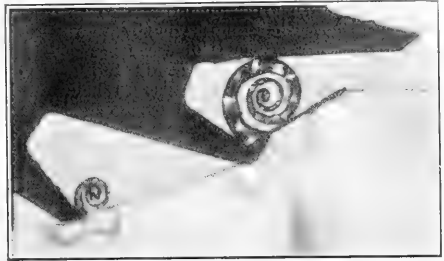

FIG. 4.—Steel milling cutter operating on a plate of nitro-cellulose.

cutter, shown in Fig. 4, where the depth of cut is variable owing to the uniform movement of the material up to the cutting edges, which are also turning at a definite and uniform rate. The shaving cut from the trochoidal contour is continuously increasing in thickness therefore, as the cut advances, and in the

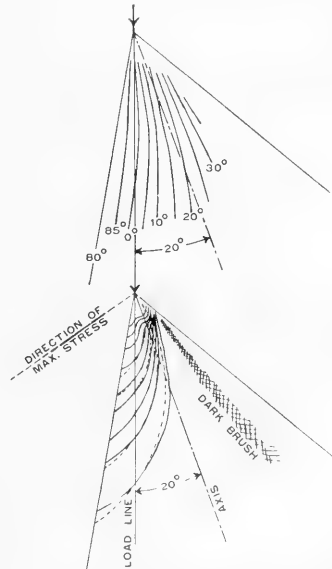

FIG. 5.—Isoclinic lines and colour bands observed and calculated for a wedge of angle 60° when a load of 50 pounds is applied at an angle of 20° with the axis. Colour bands observed are shown in full lines; equivalent stress lines given by theory are shown dotted. From the Proceedings of the Institution of Mechanical Engineers, by permission of the Council.

present instance is being torn off rather than cut, as the characteristic markings for this kind of action occur in a very pronounced manner. If sufficient travel is given to the work, the separate lobed colour bands springing from each cutting edge, and denoting approximate radial stress, ultimately coalesce before

the end of the cut, and the stress distribution becomes much more complicated.

The stress in glass tools when cutting nitro-cellulose has been studied, and it is found that when the material is being removed in a thin shaving by a true cutting action the stress system is of a simple radial type. The colour bands are very nearly arcs of circles passing through the cutting edge as indicated in Fig. 3, and are such as would be produced by the action of a concentrated force applied at this place. They are, in fact, of the same type as those obtained when a non-axial force is applied at the apex of a wedge, giving isoclinic curves and colour bands (Fig. 5), all of which pass through this point up to the yield point of the material. The centres of the circular arcs of these latter bands all lie upon a line passing through the apex and perpendicular to the dark band shown in Fig. 5, which marks the region of no stress. They are, therefore, approximately consistent with Michell's theory of stress in a wedge,<sup>1</sup> and have been shown

experimentally, in the paper referred to above, to be in good agreement therewith along the line of action of the applied force. The stress system is found to be almost entirely radial and expressed by

$$\bar{r} = -c \cdot \frac{\cos(\alpha - \phi)}{\gamma}$$

along this line—where  $\alpha$  is the inclination of the outer face to the line of centres of the colour bands, and  $\phi$  is the inclination of the applied force to the same face. Along each colour band  $\bar{r}$  is practically constant. The value of the constant  $c$  is also expressible in terms of the force  $P$ , the angle  $\alpha$  and the angle  $\gamma$  of the wedge. The stress system in the case when the material is being torn off by the action of the raking face of the wedge angle of the tool has not, so far, been made out. Experiment shows, however, that it is of a more complicated type, especially when the action is accompanied by the building up of a secondary wedge on the tool from the material torn off in a manner which is familiar to those engaged in machinery operations involving heavy cuts.

<sup>1</sup> Proceedings of the London Mathematical Society, vol. xxxiv, 1902, and Love's "Theory of Elasticity," 2nd edition, pp. 208-209.

## The New Building of the National Academy of Sciences, U.S.A.

By Dr. C. D. WALCOTT.<sup>1</sup>

IN 1863 Henry Wilson, United States Senator from Massachusetts, asked a number of men eminent in science to come together to form an organisation by which the scientific strength of the country might be brought to the aid of the government. This meeting was directly the result of an Act of Congress passed March 3, 1863, incorporating the National Academy of Sciences of the United States of America. While Senator Wilson presumably had aid and suggestions from the incorporators, the bill had its inception with, and was drawn by him, and did not incorporate the Academy in any state or territory, or in the District of Columbia. It seems to have been his idea that the Academy should be national in its broadest sens<sup>2</sup>.

The Academy has held its annual meetings in Washington at the Smithsonian Institution and its autumn meetings in other cities. Joseph Henry was president for many years and at the same time secretary of the Institution. The records and library of the Academy have been stored in several hundred boxes at the Institution, awaiting such time as the Academy may have a building of its own where this material can be made available.

The semi-centennial in 1913 gave new life to the activities of the Academy, and the foreign secretary, Dr. George E. Hale, proposed then that the Academy should have a home. He prepared tentative plans and had them put in shape by an architect. These plans provided laboratories and a library for the use of the Academy and resident men of science for research work.

The project was not to be long delayed, for the world war coming in 1914 changed and broadened the thought of the world. What started to be a battle of armed forces turned to competition between the countries at war in creative scientific research, looking

to the destruction of masses instead of individuals. This led to the need in the United States of a body that could bring together the most able men in the fields of science for the solution of war problems. Dr. Hale, conceiving the need for such a service long before it was an actual necessity, proposed that the Academy take preliminary steps in the organisation of the scientific resources of the United States, and this was the beginning of the National Research Council which rendered such effective service at the request of the President of the United States during the war.

Appreciation of this service from the Academy was shown in an executive order issued by President Wilson, directing the National Academy of Sciences to continue the Council. Under this order the Research Council was reorganised on a permanent peace basis as an agent of the Academy, and the need of the Academy for a home was accentuated. Dr. Hale's precious plans were discussed at length, but the question of available funds continued. The quarters in the Smithsonian Institution, already too crowded, could not afford room for this new body, and temporary space elsewhere was found in the Munsey Building; then a residence at 16th and L Streets, having twenty-one rooms, was secured. A little later a larger building at 16th and M Streets was occupied, until the present location at 17th and Massachusetts Avenue was leased.

Early in these renewed activities strenuous efforts were made to secure a permanent endowment and money for a building for the Academy, and a suggestion was made to the Carnegie Corporation of an endowment and building for the Academy and Research Council, resulting in an offer of 5,000,000 dollars, provided the Academy would secure a site and present satisfactory plans. The amount needed for the purchase of this site was apportioned, so that the entire country might have a part in the great enterprise. The raising of funds for the purchase of the

<sup>1</sup> Paper read before the National Academy of Sciences on April 24.

ground was accomplished through the efforts of Dr. Hale, Dr. Millikan, and others.

The lot purchased by the Academy is known as Square 88. It contains 189,755 square feet. Originally its highest point was in north-west corner and its lowest point was under water in the river at the south-east. To-day its lowest point is about 24 feet above high water and its highest 41 feet. The borings show that there is a fill of from 5 to 10 feet where the building will stand, from 6 to 28 feet of clay and sand, and from 7 inches to 3 feet of decomposed rock.

The building planned has a frontage of 260 feet and is 140 feet deep. The height above the first floor is 60 feet. The vestibule is 11 by 20 feet; the entrance hall, 36 by 21 feet; the central hall, 64 by 24 feet; the

Facing the Lincoln Memorial, the marble building in simple classical style will rise three stories from a broad terrace. On the first floor there will be an auditorium seating some 600 people, a lecture-hall holding 250, a reading-room, library, conference rooms, and exhibition halls. The basement will contain a cafeteria and kitchen. The two upper floors will be devoted to offices.

The building is the gift of the Carnegie Corporation of New York, while the ground was bought at a cost of nearly 200,000 dollars through the donations of about a score of benefactors. Bertram Grosvenor Goodhue of New York is the architect. He is one of the best-known architects in the country, and designed the St. Thomas Church, the West Point



FIG. 1.—New building to be erected in Washington, D.C., for the National Academy of Sciences and the National Research Council.

library, 36 by 64 feet; the lecture-room, 34 by 50 feet. The five exhibition halls range in size from 26 by 14 to 34 by 21 feet.

The total number of square feet of floor space, exclusive of elevators, doorways, and hallways, is 39,874. This includes exhibition space amounting to 14,571 square feet, lecture and entertainment space of 7982, and 14,786 square feet for administrative purposes. Every modern convenience and facility will be provided.

Having brought you thus far, let us assume that we are on our way to the annual meeting in 1924. Walking west along B Street, half-way between 21st and 22nd Streets, we find a broad walk on our right, with reflecting pools in the centre leading through a formal effect of trees and shrubs to a building in the middle of the square surmounting a series of terraces. It is the home of the National Academy of Sciences and the National Research Council—a marble structure of fine proportions, standing out in bold relief against the blue sky in the morning sunlight (Fig. 1).

Building, the Nebraska State Capitol, and many other buildings. The contract for the construction of the building has been let to Charles T. Wills, Inc., of New York, and it is expected that the building will be ready for occupation in the autumn of 1923. Lee Laurie, the sculptor, has been selected to do the decorations, which will symbolise and depict the progress of science and its benefits to humanity. A series of bronze bas-reliefs will show a procession of the leaders of scientific thought from the earliest Greek philosophers to modern Americans.

On passing through the entrance hall the visitor will find himself in a lobby rotunda. Here he will see in actual operation apparatus demonstrating certain fundamental scientific facts that hitherto he has had to take on hearsay. A coelostat telescope, mounted on the dome of the central rotunda, will form a large image of the sun on the white surface of a circular table in the middle of the room. Here visitors will be able to see the sun-spots, changing in number and form from day to day, and moving across the disc as the sun

turns on its axis. A 60-foot pendulum, suspended from the centre of the dome, will be set swinging through a long arc, repeating the celebrated experiment of Foucault. The swinging pendulum will mark an invariable direction in space, and as the earth of the building revolves beneath it, rotation will be plainly shown by the steady change in direction of the pendulum's swing over a divided arc.

Two great phenomena of Nature, the sun and the rotation of the earth, are thus to be exhibited. Other phenomena to be demonstrated in striking form in the central rotunda are magnetic storms, earthquakes, gravitational pull of small masses, the pressure of light, the visible growth of plants, swimming infusorians in a drop of ditch water, living bacteria, and other interesting phenomena.

In the seven exhibition rooms surrounding the central rotunda, the latest results of scientific and industrial research will be illustrated. One room will be set aside for the use of Government bureaus, another for industrial research laboratories, others for the

laboratories, observatories, and research institutes of universities and other institutions. The newest discoveries and advances in the mathematical, physical, and biological sciences and their applications will be shown in this living museum, in which the exhibits will be constantly changing with the progress of science. One week there may be displayed the latest forms of radio-telephony; the next perhaps a set of psychological tests or a new find of fossils or a series of synthetic chemical compounds. Such a mutating museum will continue to attract and instruct large numbers of visitors and residents.

We call it the building for the National Academy of Sciences and the National Research Council, but in reality it should be the national home of science in America, and will be looked upon by our fellow-citizens and the world at large as the place where the creative mind will be able to do much to bring about a better existence for the future people of the world, for it is to their enlightenment and advancement that it will be dedicated.

### The Internal Combustion Engine.<sup>1</sup>

By Prof. W. E. DALBY, F.R.S.

#### *The Influence of the Internal Combustion Engine.*

TO engineers the terms horse-power and horse-power hour have strictly technical meanings. They can be illustrated by comparing the weight and efficiency of an aircraft engine and a locomotive engine. An aircraft engine can be built with about  $2\frac{1}{2}$  lbs. of metal per horse-power as against approximately 250 lbs. of metal per horse-power in a locomotive engine. An aircraft engine requires about  $\frac{3}{4}$  lb. of fuel oil per H.P. hour as against 3 lbs. of coal per H.P. hour used by the locomotive engine, in addition to which the locomotive engine must carry about 3 gallons of water per H.P. hour. All these, of course, are round figures. It is the extreme lightness of the petrol engine in relation to its power which has made it possible to develop aircraft.

An internal combustion engine of the Diesel type is built to use heavy oils, and has provided a prime mover by means of which the submarine was able to develop so considerably during the war. Thus the internal combustion engine helped to sink our food ships, but at the same time helped to save the situation by driving the agricultural tractor. Few, perhaps, realise fully how serious was our position in 1917. Horses were required for the Army and were being taken from the farms; but the agricultural tractor replaced them at the plough and thus made it possible to maintain the necessary food supplies.

Probably the greatest effect of the internal combustion engine on our national life is its influence on road transport. Standing at Hyde Park Corner twenty years ago a motor car would have excited notice; standing there to-day it is almost true to say that the horse-drawn vehicle has practically disappeared. The internal combustion engine is displacing the horse from the streets, and is even causing the railway companies grave concern. The chairman of one of them stated at the last half-yearly meeting that

the companies had lost 9 million tons of goods, and 6 million passengers to the motor lorry and the motor car. This is a remarkable achievement for the small 16-20 H.P. internal combustion engine which is fitted in these vehicles. During 1921 about 800,000 licences were issued to vehicles propelled by internal combustion engines and the tax on them amounted to about ten million pounds.

These brief considerations indicate how profound has been and is the influence of the internal combustion engine in shaping our destinies. It has conquered the air, and has given us a prime mover useful in farming and in transport. It is influencing the policy of our railways, and will shortly so transform our outlook and our modes of life that men of to-day will appear to be separated from their boyhood not by a few decades but by a few centuries.

#### *Some Problems of the Internal Combustion Engine.*

Considering combustion from the point of view of the Kinetic Theory of gases, but without attempting to explain the nature of the differential attraction between molecules, most of the energy developed in the cylinder of an internal combustion engine arises from the fact that oxygen combines with carbon and hydrogen to develop large quantities of heat. The function of the engine is to convert as much as possible of this heat into mechanical work.

It can be deduced by the laws of gases that the molecules at 22° C. and atmospheric pressure require 729 times the volume they occupied as a liquid. This can be illustrated by "air patterns" representing the distribution of molecules in the air. Actually the molecules are flying about at a high velocity across the vessel the sides of which they are continually bombarding and therefore exerting pressure on them.

Calculation from the kinetic theory of gases shows that at 22° C. the oxygen molecules in the air are flying at a velocity of about 1600 ft. per second, the nitrogen

<sup>1</sup> From a Discourse delivered at the Royal Institution on Friday, May 26.



molecules at about 1700 ft. per second. This velocity is not the mean but the square root of the mean square of the actual velocities of the particles. The molecules collide and zig-zag about in the enclosing vessel so that it is only by imagination that we are able to conceive them as standing still and forming a pattern something like the pattern on a wall-paper.

When a spark is passed in a mixture of air and a hydrocarbon such as pentane a re-arrangement of the molecules takes place. The 5 atoms of carbon in the pentane molecule produce 5 molecules of carbon dioxide; 12 atoms of hydrogen produce 6 molecules of steam. Before ignition there are 41 molecules including 32 molecules of nitrogen. After the explosion there are 43 molecules, nitrogen taking no part in the change. Oxygen ceases to exist as a separate entity. The result is that every pound of pentane so transformed produces 10,000 lb. calories of heat.

The immediate effect of this production of heat is to increase the velocity of the flying molecules. The actual velocity of the products of combustion in the vessel depends on the mean temperature. Direct measurement of the temperatures of the working charge of a gas engine gives 2570° abs. as a reasonable temperature from which to calculate molecular velocities. At this temperature the carbon dioxide molecules are moving at 3950 ft. per second, the steam molecules at 6166 ft. per second, and the nitrogen molecules at 4950 ft. per second; these numbers being the square roots of the mean squares of the actual velocities.

The next point for consideration is the time taken to effect this change. The time-interval taken by oxygen to combine with carbon and hydrogen lies along a time scale beginning with a detonation and ending with slow burning. In a mixture of air and pentane the oxygen molecules are a long way, on the average, from the carbon and hydrogen of the pentane molecule, and also the freedom of action of the oxygen molecules is clogged by the inert nitrogen present, but the rapidity with which oxygen can combine when the circumstances are favourable is shown by nitro-glycerine.

Chemists have discovered how to produce this nitro-glycerine molecule so that oxygen lies side by side with the carbon and the hydrogen. Its action is unclogged by any other substance, and the molecular distances have been annihilated, or perhaps it would be better to say that they have become atomic distances. Moreover, the molecule contains almost the exact quantity of carbon and hydrogen required to satisfy the oxygen present. As Lord Moulton once put it, it is a case of the lion and the lamb lying down together. A mechanical shock causes an immediate transformation—the lion devours the lamb; and the time-interval for the meal is so short that it is not measurable. This is called a detonation. Chemists have by their researches shown how to combine nitro-glycerine with other substances in order to control the rate of combustion. Engineers are also trying to get control of the rate of combustion of some of the mixtures used in the internal combustion engine. Thus the chemist and the engineer are working in different parts of the same wide field of research.

Experiments initiated by Sir Dugald Clerk are now

proceeding at the National Physical Laboratory under the general supervision of the Aeronautical Research Committee for the Air Ministry. Apparatus of the most refined nature has been devised, and the research is being carried out by Mr. Fenning. Various combustible mixtures are made up in a bomb. These are exploded and then the time taken for the chemical combination to take place is recorded. Two results may be mentioned: a mixture of one part by volume of hydrogen, 2½ parts by volume of air, was compressed to 64 lbs. per sq. inch and then exploded. Between the passage of the spark and the beginning of the rise of pressure about four-thousandths of a second elapsed. The combination was complete in about the same interval of time. In another experiment the mixture was diluted with one part of hydrogen and 6 parts of air; this caused delay in the combination, which took six-hundredths of a second to complete. In such diluted mixtures the energy has to be shared by all the molecules which do not take part in the change.

The engineer is faced with two problems: the problem of a too rapid combustion, becoming a detonation, and the problem of a combustion too slow for complete combustion at high speeds.

In practice the turbulence and eddies caused by the rapid admission of a charge through the narrow annulus of an open admission valve results in quickening the rate of combustion, and it is owing to this cause that the gas engine can run at speeds greater than those corresponding to the measured rate of flame propagation for an efficient mixture. Sir Dugald Clerk found a striking difference in the area of indicator diagrams according to whether the mixture was exploded immediately after the admission valve was closed or whether it was exploded after precautions had been taken to damp out the eddies.

Among the problems arising from running internal combustion engines at high speeds is that of torsional oscillations, and synchronous oscillations. There is also the balancing problem. The four-cylinder petrol engine is usually constructed so that it is perfectly balanced for primary forces and couples, but gives the maximum error for unbalanced secondary forces. At certain speeds a model of this type suspended from springs will oscillate twice as fast as the speed of rotation of the engine, while at the same speed and on the same springs a model, balanced to eliminate the secondary forces, will run steadily at all speeds.

Other problems have also to be considered. Accurate records of the pressure-volume relation in the internal combustion engine must be obtained, and the difficulties are increased owing to the high speed at which the cycles take place. The direct measurement of temperature is also a difficult matter, and there are various fuel problems.

Sufficient has been said to show that the future of the internal combustion engine is not settled; it is full of problems requiring continuous and laborious research. The question is what provision has been made for this research. Before the war purely scientific research on the internal combustion engine was focussed largely in the Research Committee of the British Association established at the Dublin meeting in 1908. This Committee was the only one of its kind, and the

work was carried on vigorously until the war under the successive distinguished chairmen, Sir William Preece and Sir Dugald Clerk. The Committee is still in existence. There is also the Research Laboratory at Shoreham under the direction of Mr. H. R. Ricardo, himself a distinguished scientific investigator.

During the war official organisations have been established, and now the Department of Scientific and Industrial Research provides aid in money, apparatus, advice, and encouragement to any individual worker who has ideas and is qualified to carry on a research alone or under direction. This is a great national asset. But above all, so far as the petrol engine is concerned, there is the powerful organisation for Research within the Air Ministry itself, generally under the supervision of Air-Marshal Sir Geoffrey Salmond (known as the Director-General of Supply and Research), but under the immediate direction of Brigadier-General Bagnall-Wild, officially known as the Director of Research. The Air Ministry is advised by the Aeronautical Research Committee under the chairmanship of Sir Richard Glazebrook. This Committee has grown from the old Aeronautical Advisory

Committee of the late Lord Raleigh. Work of the highest scientific value is now in progress at the National Physical Laboratory, at Farnborough, and at other places under the direction of the Ministry.

All I have done here is to hint at some of the work now going on at the National Physical Laboratory; it would take a whole evening merely to epitomise the researches in progress at that institution. Farnborough is now entirely a research establishment in its widest sense, for it is organised both for laboratory and for full-scale work. Work on the internal combustion engine has reached a magnitude and an intensity undreamt of before the war. The war has, in fact, shown that the internal combustion engine instead of being a convenient prime mover to put in our motor cars, to drive our workshops, or even our ships, has become an engine vital to our very existence. The Aeronautical Research Committee realises this, and the Air Ministry also. Let us hope that the nation will realise it too, and that in the need and passion for economy our legislators will not starve research on this vital national prime mover.

## The Hull Meeting of the British Association.

### LOCAL ARRANGEMENTS.

ARRANGEMENTS are well in hand in connexion with the meeting of the British Association for the Advancement of Science at Hull, September 6-13. Hull is particularly well provided with suitable rooms for the evening discourses, public lectures, and sectional meetings. Its large City Hall, centrally situated, accommodates three thousand people, and trams for every part of the town start at its doors. In this the inaugural meeting on Wednesday, September 6, will be held at which Sir Charles S. Sherrington (President of the Royal Society) will deliver his presidential address entitled "Some Aspects of Animal Mechanism." On the following day the City Hall will be the scene of the Lord Mayor's reception.

Hull's new magnificent Guildhall provides an excellent reception-room, adjoining which the banqueting chamber makes a very fine lounge and writing-room. On the same floor are suitable rooms for the various officers of the Association, the press bureau, the meteorological demonstration given by the Air Ministry, etc. This last named will be very welcome in the reception room, where it will be seen by everybody, and in an adjoining room the methods of preparing the chart will be available to the members.

Across the road from the reception-room are the British Association refreshment rooms, the Queen's Hall (Section F (Economics) and joint meetings), Section A (Mathematics) meets in the Central Hall, Pryme Street; B (Chemistry) in Waltham Street; C (Geology) and H (Anthropology) in the Museum and Royal Institution; D (Zoology), E (Geography), K (Botany), and M (Agriculture) in the new Art School; I (Physiology) in the Church Institute; J (Psychology) in the Albion Hall; and L (Education) in the Lecture Hall, Jarratt Street. All these buildings are within three minutes' walk from the terminus of the various tram routes in the City Square.

The Local Committee is providing each member with

a small badge, which has been artistically designed and will serve as a more convenient means of identification than the somewhat cumbersome members' ticket (this latter, however, is this year to be waistcoat-pocket size and once more includes, as formerly, a map of the meeting-rooms). Each badge bears the number of the member's card, so that a reference to the index at the end of the list of members will enable the identity of any particular member to be ascertained, if desired.

With regard to the accommodation, while it is not expected that there will be any difficulty in providing for as many members as care to visit the city, the hotel accommodation which will be available for visitors is exceedingly limited. This year, therefore, a list of hotels and lodgings will not be prepared, but a special committee is sitting with the object of meeting the requirements of the members. In this connexion rooms are being provided at Bridlington, Hornsea, Withernsea, Beverley, Cottingham, Brough, Ferriby, Hessele, and other places in the immediate vicinity, but the provision of special late trains and of exceptionally favourable weekly contract tickets for this meeting will help considerably. It is desired to impress upon intending visitors to the Hull meeting the necessity of filling in the cards on the back of their preliminary programme, and returning them to the Secretary at the earliest possible moment, in order to prevent unnecessary trouble, which will certainly be caused if members arrive at the meeting without having previously notified their intention of being present. This warning seems particularly necessary, as several members have intimated their intention of being present, but neither state that they have found accommodation nor that they wish accommodation to be found for them. Those who have applied will receive particulars of their rooms shortly.

In a previous article reference was made to the various presidential addresses, with the exception of

Section J (Psychology), which was to have been by the late Dr. W. H. R. Rivers. We are now pleased to announce that Dr. C. S. Myers has accepted the presidency of this section and will deliver an address on "The Influence of the late Dr. W. H. R. Rivers on the Development of Psychology in Great Britain."

An exceptional opportunity at the Hull meeting will be afforded for discussing thoroughly the work of the Corresponding Societies of the Association. This subject has had the serious consideration of the council of the British Association for some time, and at the Hull meeting it is proposed to depart from the practice which has grown up in recent years of looking upon the Conference of Delegates almost in the light of still another section of the Association, and to revert to the former system of discussing the various ways in which the corresponding and other local societies may accomplish useful work. Conditions which obtained since the war are likely to interfere with the work of natural history, geological, archaeological, botanical, and allied societies; already the publication of the results of their work has been seriously impeded by the present charges for printing, and in many other ways it seems desirable that this Conference of Delegates shall be more of a conference than of a Section X, to which papers, not quite desired by other sections, shall be sent! Certainly in recent years the connexion between the Conference of Delegates and some of the papers presented at its meetings has been somewhat remote. At Hull, therefore, there will be no set presidential address to the conference.

Advantage will be taken of the fact that the meeting is held in the county in which probably the leading provincial society in the British Isles (that is, the Yorkshire Naturalists' Union) exists, and the way in which this society, by means of its sections, committees, publications, etc., carries out and records its researches will be explained in Hull, as probably upon such lines it will be necessary that other societies should work in the future.

The list of the distinguished members from the near continental countries, from the United States, Canada, and other parts of the world, is constantly growing, and the Hull meeting bids fair to be memorable from the part these gentlemen will take in its proceedings.

Under the editorship of one of the local secretaries a handbook to Hull and the East Riding of Yorkshire is

in preparation, and will be presented to each member. In this booklet an effort will be made to direct attention to the various attractions in the Riding, as well as to give descriptions of the city and district under the heads of geology, zoology, botany, archæology, meteorology, commerce, etc.

Elaborate arrangements are being made by a special excursions committee for general and popular excursions to Scarborough, Flamborough, Bridlington, York, Beverley, and other places of scientific interest within easy access of the city, as well as for special excursions of smaller parties of members particularly interested in geology, engineering, chemistry, and other subjects.

In addition to the handbook, a local programme is in preparation, which will contain particulars of the various directions in which the members may be occupied during their stay in Hull. The Constitutional Club, the East Riding Club, and others are electing members of the British Association honorary members of the clubs during the meeting, the Freemasons are giving a reception to their brethren, and special exhibitions of various kinds are being prepared to interest the different sections of the Association. One of these, organised by the Yorkshire Naturalists' Union, will be held in the Board Room of the Education Offices opposite the Museum in Albion Street, and will illustrate the work of the various sections and committees of that society.

The public lectures to citizens so far arranged are as follows:—Dr. A. Smith Woodward on "The Ancestry of Man"; Dr. E. H. Griffiths on "The Conservation and Dissipation of Energy"; Sir Westcott Abell on "The Story of the Ship"; Prof. A. P. Coleman on "Labrador"; and the Rev. A. L. Cortie, S.J., on "The Earth's Magnetism."

Evening discourses will be given by Dr. F. W. Aston on "The Atoms of Matter, their Size, Number, and Construction," and by Prof. Walter Garstang on "Fishing: Old Ways and New."

For the first time, special lectures are being arranged for the children in the upper classes in the secondary and other schools in the city, and these will be given by Prof. H. H. Turner on "The Telescope and what it tells us"; Prof. J. Arthur Thomson on "Creatures of the Sea"; and Mr. F. Debenham on "The Antarctic." Each lecture will be given to two thousand pupils.

T. S.

### Current Topics and Events.

AN imposing gathering of savants recently assembled in the great hall of the Sorbonne to celebrate the double centenary of the foundation of the Asiatic Society and the discovery by Jean François Champollion of the secret of the Egyptian hieroglyphs, the most important of which is the famous Rosetta Stone in the British Museum. The meeting, presided over by M. Millerand, was addressed by M. S enart, who pointed out that the Asiatic Society was founded at the period when Champollion, in his famous letter to Dacier, revealed the secret which restored to humanity five thousand years of history. Since then the Society had always been in the van of Orientalism, and Phœnician and Palestinian epigraphy and archæology owed it a lasting debt.

SIR ARTHUR EVANS, in the *Times* of July 14, announces two dramatic discoveries at Knossos. It had long been observed that the position of the walls at the South-east Palace angle indicated a sudden collapse of the building by what could only have been a great earthquake shock. The discovery of two large skulls of the urus ox, and in front of them, remains of portable terracotta altars, showed that "previous to the filling in there had been a solemn expiatory sacrifice to the Powers below—recalling the words of the *Iliad*, 'in bulls doth the Earth-shaker delight.' There can be little doubt that the great deposits throughout a large part of the Palace area, all illustrating an identical cultural phase and indicative of a widespread contemporary ruin

about 1600 B.C., were due to the same physical cause. The great earthquake of Knossos, in fact, sets a term to a Minoan period." Even more dramatic than this is the discovery on the South side of what appeared to be the opening of an artificial cave, with three roughly cut steps leading down to what can only be described as a lair adapted for some great beast. "But here perhaps," says Sir Arthur Evans, "it is better for imagination to draw rein." Was this really the abode of the Minotaur?

A BIOLOGICAL expedition is leaving Antwerp for Brazil during this month. It is under the direction of Prof. C. Massart, of the department of botany in the University of Brussels, and there are four other members of the expedition, two of whom are students. For several years before the war the universities of Belgium and Holland organised expeditions to enable students to go into the field under the guidance of their professors, and it is one of these expeditions, to Brazil, which has now been promoted by the University of Brussels. The party will not aim at exploring Brazil; the object is rather to put the young naturalists directly in touch with tropical Nature; they will have the opportunity of collecting botanical and zoological material for study and demonstration and of making ethnological observations. Brazil has been chosen on account of its salubrity and also because, some twenty days' journey from the starting-place, the party will be in the virgin forest. The expedition will remain in Brazil from August until January or February next, and visits will be paid to the States of Rio de Janeiro and Bahia, to the Campos de Minas Geraes, a region in the State of Bahia which is almost deserted, and to some of the peaks of the Serra de Mantiqueira. The necessary financial support for the expedition has been assured by the University of Brussels and the Belgian Ministers of the Colonies and of Sciences and Arts, while the Brazilian Government has promised every assistance for the success of the expedition.

THE American Museum of Natural History has recently received from Mr. J. D. Rockefeller, jr., a gift of a million dollars—the largest single donation that has ever come into its exchequer. It is the result of a long and careful inquiry which the donor has caused to be made into the value of the work done by this institution in connexion with the public schools. At the same time, Mr. George F. Baker, a leading New York banker, has given a quarter of a million dollars to the museum. The income from these gifts may be used to extend the direct educational work of the museum, or to assist its research expeditions. The most important of these enterprises being carried on at present is the sending of a party, with specially constructed automobiles, to penetrate the Great Mongolian Desert, a tract which is almost virgin soil for the archaeologist and palaeontologist.

A NOTE is given in the *Meteorological Magazine* of June from Mr. R. C. Mossman on some recent remarkable temperatures. At Buenos Aires, on the morning

of April 26, the shade minimum fell to 27°·9 F. and the grass minimum to 20°·5 F. The previous April shade minimum in the last 60 years was 33°·4 F. On March 10, at Grytviken (South Georgia), the shade maximum rose to 83°·8 F., which is 13° above the previous record.

SIR WILLIAM POPE has been elected president of the International Union of Pure and Applied Chemistry for the ensuing three years. The next meeting of the Union will be held at Cambridge in June 1923.

PROF. A. N. WHITEHEAD has been elected president of the Aristotelian Society for the coming session; he will deliver his inaugural address on November 6.

THE annual meeting of the French Association for the Advancement of Science will be held at Montpellier on July 24-29 under the presidency of Prof. Mangin, director of the Paris Museum of Natural History.

AT the annual general meeting of the Royal Society of New South Wales on May 3, Mr. C. A. Sussmilch was elected president. Mr. Sussmilch is principal of the Newcastle Technical College (N.S.W.), and was for many years lecturer-in-charge of the Department of Geology and Mining, Sydney Technical College. His contributions to science include an account of the geology of New South Wales and a number of papers on geology and physiography.

A MEETING of the Royal Meteorological Society will be held in the Rooms of the Royal Society, Edinburgh, on Monday, July 24, at 3 o'clock, when the following papers will be read: "Observations of Upper Cloud Drift as an aid to Research and to Weather Forecasting," C. K. M. Douglas; "Note on the Effect of a Coast Line on Precipitation," J. S. Dines; and "Note on Turbulence," illustrated by smoke and cloud photographs, Dr. A. E. M. Geddes and G. A. Clarke.

IN the Calendar of Industrial Pioneers in NATURE for June 24 it is stated that Singer, who died in 1817, was the inventor of the gold-leaf electrometer. Singer's invention of this instrument may have been independent, but the credit for its first invention belongs to the Rev. Abraham Bennet, who in 1789 included a description of it in his "New Experiments on Electricity." Mr. Shurlock, Principal of the Technical College, Derby, who has kindly pointed this out, says Bennet was a fellow of the Royal Society and for twenty-five years was curate of Wirksworth, Derbyshire, where he died, May 6, 1799, at the age of 49, but that little more is known of his career.

THE death of the eminent anthropologist, Dr. W. H. R. Rivers, has already been recorded in these columns. It will be satisfactory to his many friends, and to others who recognise his great services to science, to know that a full biography, with a complete list of his numerous books and articles, by

Dr. A. C. Haddon, his colleague in the Cambridge Expedition to Torres Straits, and Mr. F. C. Bartlett, appears in the July issue of *Man*. The bibliography of his published work between the years 1888 and 1922 is a remarkable record of the scientific knowledge and powers of work which this scholar possessed, and will increase the regret felt by all his friends and the students of his writings at his sudden and unexpected death in the plenitude of his activity.

At the first glance one might be tempted to remark that the science master has no concern with the teaching of English, but it is evident from the papers on the subject by Mr. Eggar and by Mr. Breames which have appeared in the *School Science Review* for June 1920 and 1922 respectively, that many science masters have to begin by teaching the boys who come to them to write English. We are told that boys of fourteen who have spent several years on the classical side of a public school are turned over to the science side unable to read English intelligibly or to write it in such a way that their meaning is clear. In such circumstances the science master's task is doubled. He must teach his boys the scientific and technical terms of his subject and also how to express themselves clearly and correctly. Mr. Breames divides the latter process into two stages. In describing an object or an experiment he trains his boys to devote one sentence to each feature or to each change. Afterwards he teaches them to combine into one longer

statement the sentences dealing with the features or changes which are closely related. He finds that this procedure produces a "respectable style" of writing in about two years.

A BOOKLET from C. F. Elwell, Ltd. (Craven House, Kingsway), shows one of the directions in which wireless telephony is developing, for we have illustrations of receiving sets made up into elaborate pieces of drawing-room furniture in the various period styles of decoration. The apparatus itself within these attractive coverings is in the form of compactly arranged enclosed standard panels, the simplest of which is equipped with a crystal detector. The more useful panels employ valve receivers, and the distance from which they will pick up messages, etc., can be extended by the addition of one or more panels of similar dimensions and appearance equipped with amplifiers. Either head telephones or loud-speaking apparatus can be used, and where the higher degrees of amplification are employed, an indoor loop aerial can replace the outdoor aerial which would otherwise be necessary.

MESSRS. H. K. LEWIS AND CO., Ltd., 136 Gower Street, W.C.1, have sent us two catalogues just issued by them, namely, "College Text Books and Works of Reference on Science and Technology" and "Works on Medicine and Allied Subjects." As the lists are carefully classified they should be very useful for reference.

### Our Astronomical Column.

It is stated in the *Times* that the proposal to remove the Paris Observatory to a new site is again under consideration. When the Observatory was erected it was outside the city boundaries, but to-day it is surrounded by busy thoroughfares and streets of tall houses. Commenced in 1667 and finished in 1671, a few years before the Greenwich Observatory, the main buildings, as seen to-day, were designed by Claude Perrault, the famous architect of the Louvre. The first director was Dominique Cassini, who had come to France in 1669 at the invitation of Louis XIV., and the directorship remained in the Cassini family for about 120 years. Picard and La Hire were among the first to work in the Observatory, and Grant, in his "History of Physical Astronomy," regrets that Picard's great merits as a practical astronomer were not recognised by his being placed at the head of it. The Observatory contains a fine collection of historical instruments and apparatus used by the distinguished astronomers and physicists who have laboured there, and once a month the public are admitted to see the Observatory and its treasures and to listen to short lectures on the instruments in daily use.

CAMBRIDGE UNIVERSITY OBSERVATORY.—It is satisfactory to learn from the annual report of this Observatory, of which Prof. Eddington is director, that its activity, which was sadly crippled during the war, two of the assistants having lost their lives, is now fully re-established. The Sheepshanks equatorial is being used for photographic determinations of proper motion of faint stars by comparison of pairs of plates taken 15 or 20 years apart, one of each pair being photographed through the glass to permit of juxtaposition of images, film to film. The regions include those around stars investigated

for parallax by Prof. Russell and Mr. Hinks from 1903 to 1905, also the region round  $\theta$  Orionis, and Kapteyn's Selected Area No. 12. Some of the proper motions are being investigated by Miss Payne (Newnham). Miss Douglas (Newnham) is studying the relation between stellar velocity and absolute magnitude.

Mr. W. M. H. Greaves has been engaged on various gravitational researches, chiefly connected with the stability of Saturn's Rings, which have been published in the Monthly Notices of the R.A.S.

HARVARD COLLEGE OBSERVATORY REPORT.—This is the first annual report issued since Dr. Harlow Shapley succeeded Prof. Pickering, who died in 1919, as director of this observatory. The report shows the wide, sweeping nature of the researches undertaken. Dr. Shapley and Miss Cannon have in hand a discussion of the distribution of stars of different spectral type and magnitudes which occur in the Henry Draper Catalogue. The investigations of stellar distances is another line of work in hand which will help in the study of the structure of the stellar system. Good progress has been made in the publication of the valuable Henry Draper Catalogue, and volume 97 has just been distributed. By the generosity of private donors the prompt appearance of the remaining volumes is now assured. Numerous discoveries as to stars with peculiar spectra have been made from an examination of the plates of the Henry Draper Memorial, among which the number of spectra having bright lines in the region of the Large Magellanic Cloud has been increased from 48 to 61. The Arequipa station is becoming yearly of more importance, and particularly so now when the distances of southern stars are so much required.

## Research Items.

**THE ART OF THE MARQUESAS ISLANDERS.**—In 1595 the Spanish admiral, Alvaro de Mendana, discovered a group of islands about midway between the Peruvian coast and New Guinea, to which he gave the name of Marquesas, a shortened form of the name of his patron, the Viceroy, Garcia Hurtado de Mendoza, Marques de Canete. In the *Museum Journal*, issued by the University of Pennsylvania, Mr. H. Usher Hall describes a fine collection of the art of the islanders, including finely carved war-clubs, warriors' fillets, amulets made from cylinders of human bones, the war conch-shell, fans carved in whale ivory and wood. The human figures used in the ornamentation of canoes are particularly interesting. The article is illustrated by an exceptionally fine collection of photographs.

**THE DEVELOPMENT OF FLINT IMPLEMENTS.**—In *L'Anthropologie* (vol. xxxii. Nos. 1-2) M. A. Vayson, under the title of "L'Étude des outillages en pierre," publishes a valuable, well-illustrated article on the development of flint implements. Two principles which he lays down deserve attention: "La similitude des outils n'implique pas la communauté de races ou de civilisation de leurs fabricants; l'identité de forme des outils en pierre ne signifie pas l'identité d'emploi. Ainsi les similitudes vu les différences des outils en pierre que nous pouvons étudier ne permettent pas de conclure nettement sur leur emploi et sur les autres industries dont ils étaient auxiliaires."

**A REMARKABLE PARASITE.**—An interesting study of the flowers of the parasite *Rafflesia Arnoldii* is published by P. Justesen in *Annales du Jardin Botanique de Buitenzorg*, xxxii. Pt. 1, 1922. The observations were made on flowers and buds growing on "vines" in the highlands of Sumatra. The paper is illustrated by good photographs showing the form and structure of the large flowers; full measurements are also given of the mature male and female flowers. It is estimated that the complete development of a flower from a prominence just recognisable on a vine root occupies almost a year, and Mr. Justesen gives tables showing the increase in size of the buds during their development. Seven mature flowers were found—four female and three male. One of the female flowers, which is illustrated, measured 64 cm. across, but the largest was 72 cm., while the largest mature male flower measured 75 cm. in diameter. The author gives some details of the ripening of the seeds, which appear to take several months to reach maturity, and he has made some interesting observations as to their dispersion. The fertilisation of the dioecious flowers also presents some unsolved problems. The author suggests that the small seeds may be carried into the earth by termites, and that in so doing they may easily bring them into contact with the roots of the vines. He also suggests, from the finding of *Rafflesia* in widely separated areas which are nearly always just within the edge of primeval forest, and close to the tracks of pigs and other animals, that wild pigs, pangolins, and mice may be the agents for the wider dispersal of the seeds. A fine model of the flower of *Rafflesia Arnoldii*, which is the largest flower in the world, may be seen in Museum No. 1 at the Royal Botanic Gardens, Kew.

**PHYSIOLOGY OF FUNGI.**—In the *Annals of the Missouri Botanical Garden* (vol. viii. No. 3) appear

two additions to the excellent series of studies in the physiology of fungi. The first, by G. M. Armstrong, is entitled "Sulphur Nutrition: The Use of Thiosulphate as Influenced by Hydrogen-Ion Concentration." Three fungi, *Aspergillus niger*, *Penicillium glaucum*, and *Botrytis cinerea*, were grown in various solutions containing different compounds of sulphur, and a study was made of the end products of thiosulphate and of its efficiency as a source of sulphur. Reversions of reaction from the more acid condition towards neutrality were observed with both *Aspergillus* and *Penicillium*. R. W. Webb, in his study of "Germination of the Spores of Certain Fungi in Relation to Hydrogen-Ion Concentration," finds that the majority of the fungi employed exhibit a distinct maximum of germination between Ph. 3.0 and 4.0. It is not until Ph. 1.5-2.5 is reached that inhibition of germination is evidenced. A study is made of the effect of different nutrient solutions such as Czapek's solution and solutions of mannite, peptone, and beet decoction, and curves of germination are given for different hydrogen-ion concentrations. In some solutions, *A. niger* and *B. cinerea* on germination produced no change in reaction, but in alkaline cultures of sugar-beet decoction caused a slight shift towards neutrality. The data presented by Webb are of considerable interest and importance and should be taken into consideration in any future study of fungicides or spray mixtures.

**GIANTISM AMONG GASTROPODS.**—The stories circulated of a gigantic gastropod in the Wealden strata of Sussex have been confirmed by Mr. B. B. Woodward in a paper on "*Dinocochlea ingens*, n. gen. et sp." (*Geol. Mag.*, 1922, p. 242). A photograph is given of a specimen lying in calcareous sandstone of the Wadhurst Clay series, and it appears that this spiral object is the cast of a gastropod that sometimes attained a length (or altitude) of 2.22 metres (about 7 ft. 3 inches). The affinities of this giant are with the Tiaridae. The shells are lost by solution, but the spiral casts show that they conformed to molluscan rules of growth. The whorls, some 23 in number, increase only slowly in size from the apex to the mouth, and the whole form is thus fairly cylindrical. Mr. Woodward shows how these objects differ from the concretions that occur in the same beds; but the seemingly abrupt appearance and extinction of *Dinocochlea* present a fascinating puzzle. The author reminds us that the Carboniferous *Actinoceras giganteum* may have been at least as large. The writer of the present note recalls the vertical cylindrical "concretions," some 10 feet in height, in the Potsdam (Upper Cambrian) sandstone of Blake's Quarry, near Kingston, Ontario, which he inclines to attribute to the burrows of gigantic worms. The notion has hitherto seemed fantastic; but surprises evidently await the palæontologist.

**THE "TURTLE-OREODON LAYER" IN S. DAKOTA.**—The Oligocene continental strata now under investigation by Princeton University in the Big Badlands of the White River, S. Dakota, afford an interesting parallel with the flood-deposits of Upper Miocene age which entombed the turtles of Old Castle (*NATURE*, vol. cviii. p. 481). Prof. W. J. Sinclair describes (*Proc. Amer. Phil. Soc.*, Philadelphia, vol. lx. p. 457, 1921) how the remains of enormous numbers of land-turtles occur in all positions in the Oredon beds, with skulls of mammals, bones gnawed by rodents, and coprolites of carnivores.

The assemblage is attributed to temporary floods sweeping across a surface on which the animals decayed. At several horizons in the Oligocene beds of Indian Creek Basin calcareous algal crusts have accumulated up to a foot in thickness, probably formed by a species of Cyanophyceae.

**PHOTOSYNTHESIS OF NITROGEN COMPOUNDS.**—In a paper published in the June issue of the *Journal of the Chemical Society*, Prof. E. C. C. Baly, Prof. I. M. Heilbron, and Mr. D. P. Hudson describe the photosynthesis of nitrogen compounds from carbon dioxide and nitrates. It has previously been reported that decisive evidence of the production of formaldehyde by the action of light on carbon dioxide and water, in the presence of photocatalysts, had been obtained. It is now found that the "activated formaldehyde" so produced can react with potassium nitrate. This reaction takes precedence of the polymerisation of the activated formaldehyde to reducing sugars. When the activated formaldehyde is produced at a rate greater than that at which it can react with the nitrite and with the form-hydroxamic acid thus formed, the excess polymerises to reducing sugars. In this case, the two reactions take place simultaneously and independently. Small traces of ammonia are frequently found in the solutions after exposure to light, and activated formaldehyde reacts with ammonia to give methylamine. This confirms Pictet's contention that formaldehyde acts in photosynthesis as a methylating agent. In the synthesis of compounds by the action of activated formaldehyde on formhydroxamic acid, oxygen is set free. The possible modes of formation of indole and quinoline compounds are discussed, and the paper is one which has great interest from the point of view of plant chemistry.

**IRON ORE IN SOUTH AUSTRALIA.**—The Geological Survey of South Australia has recently published in Bulletin No. 9 a very complete account of the iron ore resources of South Australia by R. L. Jack, Deputy Government Geologist. The iron ores of South Australia are of importance, first of all as a flux in smelting, particularly in smelting the silver-lead ores of Broken Hill; ultimately Port Pirie became the centre of this lead-smelting industry, and the bulk of the iron ore required was supplied from the important deposit at Iron Knob, which was acquired by the Broken Hill Proprietary Company. Subsequently this company took advantage of the large supply of good iron ore thus available to erect important iron and steel works at Newcastle, New South Wales. These steel works were started in 1915, and the South Australian production of iron ore went up at once from a little more than 37,000 tons to nearly 265,000 tons, while in 1921 it reached nearly 629,000 tons. Since 1919 the value of the iron ore produced has exceeded that of any other mineral product. A very large number of deposits of iron ore are described in this Bulletin, though it is obvious that the two groups, Iron Knob and Iron Monarch, with estimated reserves of 133 million tons, and Iron Prince and Iron Baron, with estimated reserves of 32 million tons, overshadow all the others in importance. Since South Australia possesses no fuel supplies for metallurgical purposes, the iron ore production is necessarily for export, and on this account the accessibility of a deposit of iron ore in South Australia forms an essential element in determining its economic importance; due regard has been paid to this point in describing the various deposits, stress being laid on those that are well suited for export purposes.

**FORMATION OF THUNDERSTORMS.**—Mr. E. V. Newnham, of the Meteorological Office, has contributed a discussion, *Professional Notes*, No. 20, on the formation of thunderstorms over the British Isles in winter. Thunderstorms are rare in winter over eastern England, but they occur more frequently in the west and north. In January during the eight years discussed, 1900–1907, storms occurred on one or two days only, on the east coast of England, but on 19 days at Blackod Point, 14 at Stornoway, and 11 at Valencia. Forty years ago Dr. Buchan showed that thunderstorms were quite common in winter in the west of Scotland but were very rare in the east. The author has attempted to explain the cause of the winter thunderstorms, following the reasoning generally admitted for the formation of thunderstorms in summer, namely, instability of the air with height caused by a rapid fall of temperature. He attributes the instability in winter to the heat imparted to the lower layers of cold air currents in disturbances which have come from cold northern regions and have subsequently travelled over a considerable area of the warmer ocean. Maps are given showing the trajectories of the January storms he has discussed. It is shown that when a thunderstorm occurred with a south-west or west wind the origin of the air was nearly always in higher latitudes, and air which traverses a long stretch of ocean seldom occasions thunderstorms unless it has come from very cold regions, but with these conditions thunderstorms usually occur.

**A DIRECT-READING SPECTROMETER.**—The Government Laboratory exhibit at the Royal Society Conversazione on May 17 included a new type of direct-reading spectrometer made by Messrs. Bellingham and Stanley, Ltd., which embodies several novel features. The optical arrangement is shown in Fig. 1. The light entering through the slit *i* is reflected

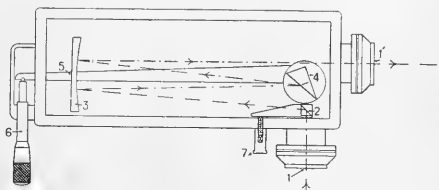

FIG. 1.

by a small right-angle prism on to a concave mirror 3, which directs a parallel beam of light on to the dispersing prism 4. The prism reflects the beam back to the concave glass mirror which brings it to a focus in a plane on the slit *i'*. The dispersing prism is mounted on a rotating table which may be turned by the arm 5 operated by the micrometer screw 6. The screw head is divided so that it can be set to pass any particular wave-length of light to slit *i'*, and thus the instrument can be used as a monochromatic illuminator. For investigations in the ultra-violet the glass prism 4 is replaced by one of quartz, and the mirror is of quartz with mercury tinfoil amalgam backing. When in use as an infrared spectrometer the dispersing prism is of either quartz or rock-salt. The chief advantages of this design are that the 30° prism is always used in the position of minimum deviation, and that with the concave mirror no chromatic differences of focus are introduced.

## Glasgow Meeting of the Society of Chemical Industry.

THE forty-first annual meeting of the Society of Chemical Industry, which was held in Glasgow on July 4-11, was the fourth occasion on which the Society has visited Glasgow, the last visit being in 1910. Last year the Society met in Canada, under the presidency of Sir William Pope, and at this year's meeting it has been honoured by the presence of its Canadian president, Prof. R. F. Ruttan, of McGill University, Montreal, with a party of visitors from Canada and the United States.

The president addressed the Society on "Some Aspects of Scientific and Industrial Research," and, after referring to the influence of the war in directing academic research into industrial channels, spoke of the lesson of co-operation which had thereby been learned, and the prominence now being given to internationalism in science. This was expressed notably in the establishment at Brussels in 1910 of the International Research Council of the Allied and Neutral Nations. The Council includes the International Union of Pure and Applied Chemistry, and its ultimate goal is to make a World Parliament of Sciences. This organisation, said the president, should do more than any other for the unification of mankind, because its underlying principle is the universalism of science and the catholicity of truth. The organisation in Great Britain of a State Department of Scientific and Industrial Research has given rise to similar Departments in the Overseas Dominions and the United States. In consequence, a dearth has been revealed of men sufficiently trained and laboratories suitably equipped for research. One of the first problems to be faced by the research organisations is how permanently to associate those pursuing abstract science with those concerned with its application. Universities must be regarded as holding their laboratories and equipment in trust for the community; and they are responsible for inculcating the principles and habits of work which underlie all research. The countries of the Empire expect capacity for research from the scientific departments of their universities, and the universities must therefore have adequate State aid to discharge these responsibilities. Further, Prof. Ruttan advocated the establishment of a State-aided Research Institute in Great Britain, where future scientific and industrial research would be suitably blended. A compromise must be made between scientific ideals and industrial needs; and scientific research should become an accepted responsibility of the State, as certain and permanent as that of national education.

A noteworthy feature of the present meeting has been the inauguration of the Messel Memorial Lectures, established by means of a legacy to the Society of Chemical Industry by the late Dr. Rudolph Messel, which was to be applied for "... the furtherance of scientific research and such other suitable objects as the Council of the Society may determine." The first Messel Medal was presented to Prof. H. E. Armstrong, who delivered a lecture entitled "Rhapsodies culled from the Thionic Epos."

The title of Prof. Armstrong's lecture is explained by the fact that Dr. Messel was the pioneer in the manufacture of sulphuric anhydride by the aid of a platinum catalyst. Besides discussing the mechanism of catalysis and the influence of water in chemical

change, the lecturer made an earnest plea for clear thinking in science, for free criticism and exchange of opinion, and for the development of a philosophy of science based on experience. Prof. Armstrong said he was glad that, after the great attention which had been paid to the physical aspects of chemistry, a return was now being made to the consideration of molecular structure, and the inner meaning of chemical phenomena. Advance in the domain of organic chemistry has outstripped that in other branches, because in them there had been little effort to develop a theory of chemical change on the foundation laid by Faraday.

Papers were read by Dr. J. W. M'David on "A Rapid and Accurate Method for the Calibration of Storage Tanks," a method which depends on the time taken to fill the tank to a given level by water forced through an orifice by a constant head; and by Dr. R. A. Joyner on "The Viscosity of Cellulose in Cuprammonium Hydroxide," a novelty described being the preparation of the reagent by dissolving finely divided copper in aerated ammonia solution.

The remaining papers of scientific interest were provided by the Engineering Group, which, in its fifth conference under the chairmanship of Mr. J. A. Reavell, considered the subject of evaporation and distillation.

In an introduction to an abstract of the papers the relation between evaporation and distillation with reference to modern types of plant was emphasised. Mr. P. Parrish presented a paper on the design of ammoniacal liquor stills, in which the origin of the present type of still was traced, details of the composition of ammoniacal liquor were given, and the distinguishing features of the various kinds of still were discussed, together with the physico-chemical principles involved in their use, and the probable lines of future development. Mr. W. A. Walmesley dealt with tar distillation. In this paper the differences in composition between tar from horizontal and from vertical retorts were considered, and details were given of experiments on the continuous distillation of tar, which yields a greater output than the intermittent process. The treatment of tar fractions was outlined, experiences with modern distilling columns were described, and lines of desirable progress suggested.

The general problem of evaporation was reviewed by Prof. J. W. Hinchley. The influence of various conditions of temperature, atmospheric pressure, and hygroscopic state, radiation, and air-contact upon evaporation was considered. Appropriate evaporation formulae were developed, their application to details of engineering design was discussed, and their economic importance emphasised. Mr. T. H. Gray read a paper on the historical development of the distillation of glycerine in which interesting drawings of plant were submitted. The importance of economic working was pointed out and the high state of purity of the modern product emphasised. The value of all these papers was much enhanced by the discussions by which they were followed.

A handbook of the meeting had been prepared by the local secretary, Dr. J. A. Cranston, which contained a useful account of the chemical and allied industries of Glasgow and the West of Scotland, prepared by Mr. W. H. Coleman. R. M. C.



## The Development of Research in Universities.<sup>1</sup>

By Principal IRVINE, F.R.S., Vice-Chancellor of the University of St. Andrews.

FOR some years it was my privilege to direct the work of a research laboratory where young graduates were trained in research methods and, after a period of collaboration, enabled to strike out independent lines of inquiry for themselves. This endeavour to make research work an organised part of the university's activities was successful, and it occurs to me that the experience thus gained in miniature may be of service in discussing the larger problems associated with the development of research in all subjects, in all universities.

It is not necessary to defend here the idea that research is a vital necessity. My plea is that, although much has been done, our research efficiency as a nation can be vastly improved and the full advantage reaped from present expenditure by changes which in themselves would not be expensive. The functions of a university are threefold: to satisfy the intellectual needs of the people, to lead the communities we serve, and to add to the store of human knowledge. Yet it must be emphasised that every advance made by investigation is something more than a mere addition to knowledge; it means also that some one has gained a rich experience. It is not so much the prize as the discipline of training and the joy of supreme effort which makes any contest worth while, and this applies equally in the world of intellect as in the realm of sport. The universities should not leave original research to the solitary worker, to the unaided enthusiast, but must place facilities for research in the way of every one naturally equipped with the spirit of inquiry.

These ideas are widely spread and are all but universally accepted. The movement in favour of the research development in the universities has suddenly taken shape after many years spent in educating public opinion. Glance for a moment at the phases through which it came into being. In doing so I confine myself meanwhile to research in experimental science, where development has been most rapid and is most easily traced.

I commence with the institution of the 1851 Exhibition Research Scholarships, a wise step which placed at the disposal of a few selected graduates the means necessary for extending formal study by research work.

On this was modelled some nineteen years ago the research scheme of the Carnegie Trust which has done so much to improve the efficiency of the Scottish universities. Whatever views may be held regarding the payment of university fees by the Carnegie Trust there can be only one opinion as to the wisdom and success of this feature of their activities. Notice the points of distinction between the Carnegie Trust Scheme and that of the 1851 Exhibition Commissioners. The latter is confined to scientific subjects alone, and, until recently, scholarship awards were made on one uniform standard. On the other hand, the Carnegie Trust also opens the door to literature, language, history, and economics. The award begins with a scholarship, and from this the best scholars are promoted to fellowships and ultimately to research assistantships, which include teaching duties. There is thus a steady weeding-out process at work, and only the best survive.

There are, of course, other research organisations operating in the universities, but I may pass at one step to the national scheme now administered by the Department of Scientific and Industrial Research. The details of this scheme follow closely the lines adopted by the Carnegie Trust for the universities of Scotland, but differ in the exclusion of non-scientific subjects.

I question very much if the full measure of advantage afforded by these schemes could ever have been attained if the universities had not taken the common action of instituting the Ph.D. degree. Now we are launched on this great new effort. The word "research" is on every tongue. In many subjects of study provision has been made for financing the way to research, and the universities have recognised the movement by the award of the new doctorate. What obstacles and difficulties have already been encountered and what have we still to guard against? These are among the questions I try to answer from an experience admittedly incomplete. Let us take the features common to all universities, irrespective of size or location, and to all subjects of study. The first urgent need I perceive is that our research organisation must recognise the claims of three distinct classes of original workers. These are: First, the young graduate, attracted sometimes by the genuine spirit of research, sometimes by less worthy motives, who in practically all cases is immature and untrained. Then there is the second class, represented by the university lecturer who has passed the apprentice stage and couples with teaching duties the continuation of his researches, frequently through love of the work, sometimes through recognition that worldly wisdom and the hope of a chair make it advisable. In the third place, we have the mature worker and thinker, represented by the professor, the man whose experience is ripe but whose time, already getting short, is fully occupied with other things.

Each class merges into and feeds the other, and all three classes need help. Prudence points to using the mature material to the best advantage, yet we have never done so, and the research schemes of to-day make the situation infinitely harder than before. The bulk of support is now afforded to the graduate research worker. Scholarships are awarded generously and widely. The conditions attached are moderate and reasonable, and there is now a rush to research. But the young worker has to be trained, supervised, guided, inspired, and this help can come only from the members of my two upper classes—the lecturers and the professors. I wish specially to emphasise this necessity, for I have seen too many good research workers spoiled and discouraged through lack of help, and too many moderate workers developed into investigators of the first rank by careful guidance. Such supervision and training involve the complete absorption of the time and energy of the mature investigator. There can be no formal course of instruction, no common course applicable to all pupils and all topics. Each individual has to be studied. There must be the daily consultations at the laboratory bench, in the library, and round the study fire.

The question of training and supervision must be taken seriously; there is a great danger, particularly in scientific subjects, that this has not been fully appreciated. How great is the temptation in such subjects to use the technical skill of the graduate

<sup>1</sup> From an address on "The Need for the Provision of Enlarged Opportunities for Advanced Study and Research in the British Universities," delivered at the annual Conference of Universities of Great Britain and Ireland, held in London on May 13.

to carry out one's own researches, to regard these young workers as so many extra pairs of hands. Even when the responsibility of becoming a research supervisor is fully recognised, how difficult it is to put oneself in the position of the beginner. The unexpected result is obtained, and the supervisor immediately explains it out of his long experience. What benefit does the student derive? The real supervisor has to curb his impatience and lead his collaborator to sum up the evidence and at long length reach the conclusion for himself. But that takes patience, sympathy, and, above all, time. The supervisor has his reward when gradually the research pupil reveals himself and emerges as an independent worker, but his own research output fades away. There is a novel called "The Devourers," in which a woman of genius finds her artistic development arrested when in time her children claim her every thought. Just as children are in this sense the devourers of their mothers, so are research students the devourers of their professors. When I relinquished my chair I was spending daily three hours at teaching and seven hours with the "devourers."

My first two points may be summarised thus:

(1) Research training must be thorough and must be taken seriously, both by the student and the supervisor.

(2) This training must be in the hands of mature investigators, who should be relieved of routine or administrative work and who need undertake only a limited amount of teaching.

This will cost money, and staffs must be enlarged to supply the main bulk of routine university teaching. There is plenty of room in university organisation for the patient conscientious teacher on whom the gods have been kind enough to bestow only a modest passion for inquiry. Nevertheless, the research supervisor himself must be a teacher and must mingle freely with undergraduates so as to recognise at the earliest possible stage the potential research workers of the future and to guide their studies accordingly.

The needs of the lecturer class of research workers are easily defined. They require more leisure for research than they get at present, and this freedom must not be secured through the agency of overwork and late hours. It should be defined and form part of the terms of appointment. So many hours in the day, so many days in the week, or weeks in the academic year, should be kept free from teaching or administrative work. Here again we encounter the question of finance. Additional staff must be provided, and for this more money is required. In this connexion the research assistantships recently instituted by the Carnegie Trust are a step in the right direction. One other point appeals to me strongly and involves no finance. Every facility should be given the lecturer-investigator to secure collaborators to work under him. I do not mean, of course, that the professor should take the pick of the bunch and leave the residue to his juniors. Every professor should pass a self-denying ordinance on himself in this matter, and, frankly speaking, he will find that it pays.

The professor's needs have already been dealt with, but there is another thing in which we can help him. Again it is a domestic matter. It is, I am convinced, a mistake for a governing body to call for an annual list of publications from their research departments. Nothing could be more injurious to the true atmosphere of research than the feeling of pressure; that papers must be published or the department will be discredited. Thus we have scrappy, incomplete accounts of topics which

have been chosen apparently for no other reason than that results will come quickly. One point more regarding the professor: Let him have as much financial support for his work as can be spared, but it is well to insist on his keeping these accounts separate from those concerned with university teaching. But these are perhaps petty details compared with the greatest need of the professor-investigator—the necessity to be free at intervals to travel to other centres and refresh himself in the company of kindred workers.

What I have said appears to me to apply generally to all forms of university research and is founded partly on experiences other than my own. I turn now to concrete suggestions. The first and most important is that in each university there should be a Board or Standing Committee entrusted with the supervision of higher study and research. We have Entrance Boards, or Matriculation Boards, governing and regularising the first phase of university study, and it is equally necessary to have such a body assisting in the highest studies. The functions of such a body would be widely varied, and should include the power (1) to recommend additions to the teaching staff in departments actively engaged in research work and to recommend promotion; (2) to allocate money voted from university funds for research purposes, and to see that subjects which are denied benefits from Government or public schemes are properly supported (I speak more particularly on behalf of classical and philosophical subjects, which are in a serious position to-day); and (3) to supervise higher degrees, including approval of the topics given to students.

These need not be elaborated; but here are some specific needs which such a body at once encounters: (1) The provision of research libraries in which reference works can be consulted in the department where the work is carried out; (2) travelling grants to enable workers to visit libraries, to consult authorities, to inspect MSS., or carry out investigations in the field; (3) publication grants, so that where no periodical literature is available in which research results can be published, the work will not remain buried and obscure—the classical and philosophical workers in particular have difficulty in finding a publication medium; and (4) special assistance for subjects not included in National Research Schemes.

As a matter of practical convenience the policy of establishing separate suspense accounts for each of the above has been adopted in the University of St. Andrews, so that heavy expenditure in one year is balanced by accumulations.

An organisation such as I have outlined is, of course, open to some objections. Research cannot be machine-made; it cannot be governed by regulations or committees. The very word "research" is an expression of intellectual freedom. But some organisation is necessary. It is effected on lines similar to those sketched by the Carnegie Trust in Scotland and in miniature within my own university. The system works well in that the available money is fairly distributed without reference to utilitarian demands. All classes of research workers are stimulated by the feeling that their interests are being looked after and that no subject has preferential treatment. The classical scholar can work in harmony with his scientific brother and without a feeling of envy. Above all, it is a step towards the safeguard that all subjects of inquiry will be prosecuted in the universities, and we may be saved from the degradation of a one-sided intellectual development. The system educates even the mature investigator, and I am sure it is a good thing for the twentieth century chemist to

learn something of, say, the social conditions of the twelfth. Then again, the danger is minimised that a young worker will be given, as is so often the case, an absurd problem, either fully explored, or hopelessly ambitious. In many branches of study the research enthusiasts have got their chance now, and they will have to work hard to justify it. The greatest need is money, so that all subjects may be helped, and our greatest difficulty will be to spend it wisely.

### English Place-names.

AT a meeting of the Royal Anthropological Institute held on June 27, Prof. A. Mawer, of the University of Liverpool, read a paper on "A Survey of English Place-names." He said that from the earliest times the value of place-names as a possible source of historical knowledge has been recognised. Much early history has frankly been invented from them, and historians have speculated freely as to their meaning. More recently, scholars like Kemble have seen the possibilities latent in place-names; but until Prof. Skeat first put place-name study on its only secure basis, namely, the study of the early forms of the names, most of the work in this direction was only idle speculation. Conducted on scientific lines, place-name study could do much to throw fresh light on the dark places in the history of our country and its civilisation, where we had no documentary evidence or only such as has long been worn threadbare. Place-names and archaeology are the only unworked sources of evidence still remaining open to us, and these studies should be conducted in close touch with one another. With the aid of place-names, not only should we have fresh light on long-standing problems, but we should also be furnished with excellent illustrations of many phases of our history and culture.

At present we are only at the beginning of these studies. Much had been done by individual scholars upon single areas, but it has gradually come home to workers in this field that, in addition to such work, we also need co-operative effort, if ever we are to glean the true harvest of knowledge from place-names. The reasons for this are that (1) no safe inferences, either particular or general, can be drawn with reference to the names of any area except in the light of the full evidence for at least the whole of England; (2) the range of interests, historical, linguistic, topographical, and archaeological, concerned in the problems of place-names is so wide that they could not be dealt with adequately by any single scholar. These considerations have moved a small body of scholars representative of the various interests named to initiate, under the patronage of the British Academy, a scheme for a survey of English place-names with a view, not only of the interpretation of the individual names, but also of drawing from them all that wealth of historical and cultural lore which is latent in them. During the first six months of work of the survey, a start has been made in several counties; many eminent scholars skilled in the various aspects of the work are giving active help, and close relationships have been established with the two public offices most immediately concerned in the matter, namely, the Ordnance Survey and the Public Record Office.

In opening the discussion, Mr. H. J. E. Peake expressed his gratification that the projected survey of English place-names was not to proceed upon purely linguistic lines, as had been done by earlier workers on this subject, but that archaeological, historical and geographical evidence was to be taken

into account. The organisation of local branches and local correspondents in this country which the Royal Anthropological Institute had just initiated, might well be of assistance in the work of the survey on these lines. In connexion with the survival of pre-Saxon elements in place-names, to which Prof. Mawer had referred as an instance in which archaeological evidence might be brought to bear upon this problem, he indicated the possible connexion between the element "leck" (*e.g.* in Leckhampton) and a stone, monument or other, and between the element "wick" (*e.g.* Wickham) and Roman roads. The unknown site of the battle of Wodensburgh, wrongly identified with Wansdyke, to which Prof. Mawer had referred, he himself had identified by archaeological evidence within the bounds of Aston Priors, the name possibly surviving in the neighbouring Woodborough. Dr. Singer emphasised the necessity for the study of anthropology of this country, as well as that of the primitive peoples of other parts of the world, to which attention had hitherto been too exclusively directed, and Mr. Nixon gave instances of explanations of Yorkshire place-names which he had obtained by investigations in Norway.

### University and Educational Intelligence.

ABERDEEN.—The recent graduation ceremony on July 13 was one of the heaviest ever carried through; there were 224 degrees conferred, which included 101 in arts and education, 60 in science and commerce, and 57 in medicine. The special graduation of the previous week was devoted wholly to conferring the degree of LL.D. on ex-President Taft. The Vice-Chancellor, Sir George Adam Smith, presided on both occasions.

EDINBURGH.—Mr. J. A. S. Watson has been appointed to the chair of agriculture and rural economy in succession to Prof. Robert Wallace, retired. Prof. Watson was demonstrator in botany under Sir Isaac Bayley Balfour, afterwards continuing his studies in Germany, America, and Canada. He has been lecturer in agriculture in the University for some time.

At the graduation ceremony last week a "record" number of five hundred graduates were capped by the Vice-Chancellor, Sir Alfred Ewing. The B.Sc. degree in mining was conferred for the first time.

LEEDS.—Dr. W. MacAdam has been appointed medical tutor and registrar. Dr. MacAdam is a graduate of Glasgow University. He was awarded the Brunton Memorial prize as the most distinguished graduate in medicine of the year, and, after completing his University course, held the McCunn scholarship and the Carnegie scholarship in physiological chemistry. For two years he was senior assistant tuberculosis officer in Sheffield, and was at the same time a demonstrator in Sheffield University. He has been lecturer in pathology at the University and has held a number of medical posts. Mr. H. W. Symons and Mr. P. J. Moir have been appointed clinical assistants in surgery; both have been closely associated with hospital work for some years. These appointments, to new full-time posts, mark an important step in the development of the clinical teaching of medicine and surgery.

MANCHESTER.—The Council has appointed Prof. J. S. Dunn to the Procter chair of pathology and pathological anatomy in succession to Prof. H. R. Dean. Prof. Dunn at present holds the chair of

pathology at the University of Birmingham. Mr. W. W. C. Topley has been appointed to the chair of bacteriology and to the directorship of the Public Health Laboratory. Mr. Topley is at present director of the Institute of Pathology and lecturer in bacteriology and pathology at Charing Cross Hospital, London.

It is announced that Mr. R. M. Wilson, at present principal of the East Anglian Institute of Agriculture, Chelmsford, has been appointed principal of the South-Eastern Agricultural College, Wye.

THE Empire Cotton Growing Corporation will shortly appoint an assistant for cotton research in St. Vincent, West Indies, whose duties will consist of genetics research on the cotton plant. The salary offered is 600*l.*-700*l.*, with free bachelor quarters. Further particulars are obtainable from the Secretary of the Corporation, Millbank House, Millbank, S.W.1. The latest date for the receipt of applications for the post is Thursday, August 10.

A NUMBER of evening advanced courses in technology are being organised as usual for the coming session by the University of Leeds. Students who are under the age of twenty-two are required to produce evidence of adequate preparation for the courses or to pass an entrance examination before they will be admitted. Courses are held in civil, mechanical, electrical, and gas engineering, coal mining, textile industries, colour chemistry and dyeing, leather industries, fuel, metallurgy and geology. Many of the courses are specially suitable for those desirous of undertaking research work.

Two Frecheville Research fellowships are being offered by the Imperial College of Science and Technology, South Kensington, to aid in carrying out any investigation or research connected with mining, mining geology, metallurgy, or the technology of oil, which, in the opinion of the Selection Committee, is of sufficient use or promise. Each fellowship will be of the annual value of 300*l.*, tenable for one year, with a possible renewal for a second year, and the holder will be expected to devote his whole time to the work of the fellowship. Further particulars may be obtained from the secretary of the college, and all applications must be lodged with him before September 1, information being furnished at the same time as to the qualifications of the applicants and the nature of the proposed investigations.

THE president and council of the Royal Society propose to create a Foulerton Research Professorship and a Foulerton Research Studentship, the duties respectively of each being "to conduct such original researches in medicine or the contributory sciences . . . as shall be calculated to promote the discovery of the causes of disease and the relief of human suffering," and "to conduct researches in medicine or the sciences under the supervision and control of the managing committee." The annual value of the professorship will be 1400*l.* and that of the studentship 700*l.* Members of either sex are eligible for appointment. Applications must reach the Royal Society, Burlington House, Piccadilly, W.1, by, at latest, October 31.

THE West Indian Agricultural College, which has materialised as the result of the report of a committee on the question, referred to in NATURE of April 1, 1920, p. 153, will be opened in October next, in temporary accommodation which has been acquired

at St. Augustine, Trinidad. Sir Arthur Shipley, who represents the University of Cambridge, is chairman, and Sir David Prain, representing with Mr. E. R. Darnley, the Secretary of State for the Colonies, deputy chairman of the governing body, on which will be also representatives of the University of Glasgow, the Royal Botanic Gardens, Kew, and the Imperial College of Science and Technology. The College will aim at providing a three years' diploma course in tropical agriculture for those desirous of following the business of tropical planting, and a shorter course for those unable to take the full course; there will also be facilities for research. Sir Francis Watts will combine the duties of Principal of the College and Commissioner of the Imperial Department of Agriculture, which has been amalgamated with the College. The College has offices at 15 Seething Lane, London, E.C.3, and further details of the courses can be obtained from the secretary, Mr. A. Aspinall, at that address.

PROF. ALEXANDER MAIR, writing in the Bulletin of the Association of University Teachers, says—"Research . . . is the fashionable cant word of our generation." He deplores "the fact that so many men and women . . . are induced to spend one or two important years in doing pedestrian work that could equally well be performed by an intelligent mechanic or clerk" owing to the fallacy that free creative activity can be commanded by a mere fiat. A similar warning is embodied in an article on Medical Research in the report for 1920-21 of the president of the Carnegie Foundation for the advancement of teaching. "Every college and university," he says, "covets the reputation of being a centre of research. . . . The result of this striving is that the thing which ought to be the greatest inspiration toward good teaching has become only too often an excuse to escape the primary duty of teaching." In Prof. Mair's article reference is made to "an inquest into the whole question" (of research by members of university staffs) which, it seems, the Association of University Teachers is undertaking.

THE retirement is announced, on the ground of failing health, of Mr. Sidney H. Wells from the post of Director-General of the Department of Technical Education of the Egyptian Government. Mr. Wells was appointed to that position in 1907 upon the creation of the department by Lord Cromer, and during his fifteen years' service has organised technical, agricultural, commercial, and industrial education in all branches. Generally speaking, schools of three grades in each of the sections named, elementary, intermediate, and higher, have been created, and there are now nearly fifty different institutions at work in the country extending from Alexandria to Assuan. With the creation of the Ministry of Agriculture, the direction of the agricultural schools was transferred to that Ministry, and it is intended to incorporate the Higher Colleges of Engineering and Architecture, and of Commerce, with the proposed new Government University of Cairo. For his work during the war as Director of Civilian Employment for the Egyptian Expeditionary Force, Mr. Wells was mentioned in Lord Allenby's despatches and in 1919 was awarded the C.B.E. He also holds the insignia of Grand Officer of the Mejidieh Order, and of the Order of the Nile conferred by the Khedive Abbas and Sultan Hussein for his services to Egypt. Mr. Wells will be remembered as the first Principal of the Battersea Polytechnic, which position he held from the building of the institute until his departure for Egypt in 1907.

## Calendar of Industrial Pioneers.

**July 23, 1875.** Isaac Meritt Singer died.—The story of the sewing machine is one of the romances of modern industry. To such as Thomas in England, Thimmonier in France, and Howe and Wilson in America are due the main features of the machine, but it was the Boston mechanic Singer who made it available for even the poorer people. Singer patented his machine in 1851; the Singer Manufacturing Company dates from 1863, while the annual output of machines rose from 21,000 in 1863 to 800,000 in 1896. To-day the Company produces more than 2,000,000 machines a year.

**July 23, 1876.** Henry Deacon died.—A successful industrial chemist, Deacon was born on July 30, 1822, in London, where at an early age he came under the influence of Faraday. He was trained as an engineer by James Nasmyth—for whom it is said he made the first model of the steam hammer—and afterwards became manager of glass works and chemical works. In 1855, with Gaskell, he founded the firm of Gaskell, Deacon and Co., manufacturing carbonate of soda, attacking the ammonia soda process, and taking out many valuable patents. With Gossage and Muspratt he was one of the founders of the prosperity of Widnes.

**July 24, 1899.** Sir Arthur Thomas Cotton died. — Like his contemporary, Sir Proby Thomas Cautley, Cotton was trained as a soldier but became a great irrigation engineer. He not only carried out many of the earliest and most important irrigation schemes in India, but he founded a school of hydraulic engineers, which is still engaged in the development of the resources of the Indian rivers.

**July 25, 1843.** Charles Macintosh died.—Born in Glasgow, December 29, 1766, Macintosh was enabled to attend Black's lectures at Edinburgh, and in 1786 he set up as a manufacturing chemist. In 1797 he started the first alum works in Scotland, and for many years was connected with Charles Tennant of the St. Rollox Works, Glasgow. His name is popularly known at the present time, however, for his invention in 1823 of a method of making cloth waterproof by cementing two thicknesses together with a solution of rubber in naphtha, an invention which, together with the discoveries of Goodyear and Hancock, laid the foundation of the rubber industry.

**July 28, 1886.** Sir John Anderson died.—An eminent mechanical engineer, Anderson was trained in Scotland, and after working with Fairbairn, John Penn, and David Napier was appointed in 1842 to Woolwich Arsenal, where he effected a complete revolution in the method of manufacturing guns and small arms, and ultimately became superintendent of machinery. He wrote a treatise on the strength of materials, lectured at the Royal Military Academy, and was officially connected with some of the great exhibitions.

**July 29, 1708.** Swalm Renkin died.—Known as the constructor of the famous "Machine de Marli," Renkin was born at Liège in 1644, and at an early age acquired a high reputation for his skill as a carpenter and millwright. Employed by Louis XIV. on the plans for conveying the water of the Seine to the fountains and works at Versailles, Renkin began the great machine in 1675 and completed it in 1682. The machine is said to have cost 8,000,000*l.* It consisted of 14 water-wheels driving no fewer than 253 pumps, some of which worked at a distance of three-quarters of a mile by chains and rods. The water was raised in three stages to a height of 533 feet, whence it flowed to Versailles by an aqueduct. This "gigantic specimen of a race of mechanical megalosaurusians" was dismantled in 1817, and the water pumped by one of Watt's steam engines. E. C. S.

## Societies and Academies.

## LONDON.

**Faraday Society, June 26.**—A. W. Porter and J. J. Hodges: The law of the distribution of particles in colloidal suspensions with special reference to Perrin's investigations. Perrin found that the particles of a suspensoid distribute themselves according to the same law as the molecules in an atmosphere of gas; but his experiments extended over only a very small range of depth. Observations have been extended over a much greater range and wide divergence from the gas law is found; e.g. for the concentrations employed the concentration becomes sensibly uniform in a depth of one millimetre. Curves are fitted to the observations and the question is examined theoretically as well as experimentally.—W. R. Cooper: The electrochemical effects produced by superimposing alternating currents upon direct currents. Previous authors have shown that when an alternating current is superimposed on a direct current increased corrosion is obtainable and the overvoltage may also be reduced. It is now found that low frequency currents do not affect the amount of deposition or corrosion in the case of copper plates in copper sulphate. The view expressed by Goodwin and Knobel that alternating currents affect hydrogen overvoltage only when the conditions are such as to give a reversal of current in each period appears to be incorrect. The effect increases as the strength of the alternating current is increased, but the percentage effect becomes less, and takes an appreciable time to pass off when the current is discontinued. With platinum wire electrodes in dilute sulphuric acid, low frequency current gives the greatest effect when the applied voltage for the direct current is below the decomposition voltage, but this is not the case with high frequency currents. The absorption of hydrogen is very marked and there are other differences between the electrodes. If a fine platinum wire and a comparatively large platinum surface are used as electrodes, a high frequency current causes an electric discharge to take place under certain conditions. The resulting bubble forms in the body of the electrolyte, at a distance from the electrode, and the discharge is luminous in the dark.—T. M. Lowry and E. E. Walker: Expansion and shrinkage during caking of potassium carbonate. Photographic evidence is given of the expansion and subsequent shrinkage of an old package of potassium carbonate, after emptying out into a jar. Attempts to produce artificially such an expansion in various modifications of potassium carbonate have led to negative results. A possible explanation of the expansion assumes the presence in the material of a sesquihydrate, which expands on conversion into the dihydrate. Data are given in reference to the methods of preparation of this sesquicarbonate.—T. M. Lowry and L. P. McHatton: The powdering of minerals by decrepitation. The decrepitation of barytes may be attributed, as in the case of water-soluble salts such as lead nitrate, to the presence of included water; clear fragments have been obtained which are completely resistant to decrepitation by heat and a semi-quantitative relationship has been found between the water-content of barytes and the fineness of the powder produced by decrepitation. The decrepitation of celestine, crocoite, and common salt has also been investigated.—A. M. Williams: Two properties of powders. It is suggested that specific surface should be referred to unit mass and not to unit volume, owing to the relative difficulty of measuring

the latter in the case of substances in a state of fine division. The heat of immersion is discussed and its relation to the apparent specific volume of a powder as obtained by the immersion method, and a new criterion to distinguish between a physical and a chemical change in certain cases is given.—**J. L. Haughton** and **G. Winifred Ford**: A note on the systems in which metals crystallise. In the majority of cases the system in which a metal crystallises depends on its position in the periodic table. Alloys which form a homogeneous series of solid solutions right across the diagram generally crystallise in the same system. There is apparently no relationship between the changes which occur in the physical properties of metals at the melting-point, and their crystalline habit. A possible exception is the electrical resistivity of the metals in the odd series of group 5.—**A. J. Kieran**: The electrical conductivity of hydrochloric acid and potassium chloride in presence of sucrose. The equivalent conductivities of hydrochloric acid, through a wide range of dilution, were determined in the presence of varying quantities of sucrose, the concentration of the latter being maintained constant in each series of measurements. While the behaviour of potassium chloride in presence of sucrose is normal, in that the equivalent conductivity increases regularly with increasing dilution of the salt to an asymptotic limit, that of hydrochloric acid is abnormal, the equivalent conductivity passing through a maximum and falling thereafter with increasing dilution. This is connected with the relatively minute traces of electrolytic impurity present even in the purest samples of sucrose obtainable. The nature of the abnormality is of interest in view of the close association of minimal amounts of electrolytes with other organic substances of high molecular weight.

## PARIS.

**Academy of Sciences, June 19.**—**M. Emile Bertin** in the chair.—**Marcel Brillouin**: The isotropic field. Heterogeneous fluid sphere.—**Maurice Leblanc**: A new freezing machine with air as the working fluid. A detailed description, with diagrams, of a machine based on the principles given in an earlier communication (June 12). The results obtained by this machine will be published later.—**Charles Dépéret**: An attempt at the general chronological co-ordination of the quaternary period.—**A. Rateau**: The pressure and specific gravity of air in a normal atmosphere.—**M. Riquier**: The elimination of arbitrary constants.—**G. Friedel** and **L. Royer**: The liquids of Grandjean with equidistant planes.—**M. Charles Gravier** was elected a member of the section of anatomy and zoology in the place of the late **M. Ranvier**.—**M. Gosse**: Partial differential equations of the second order integrable by the method of Darboux.—**Bertrand Gambier**: Applicable surfaces with equality of the principal radii of curvature.—**L. Dunoyer** and **P. Toulon**: The polarity of the electric arc.—**B. Szilard**: A new electrometer with rigid pointer designed for the measurement of radiations. A description and diagram of the instrument are given; the advantages claimed are transportability, easy adjustment to the zero of the scale, and sensibility. A visible displacement is obtained with 0.01 gram black uranium oxide free from uranium-X.—**F. Guéry**: A curious property of a special mounting of electrical machines excited in series.—**Edouard Belin**: The transmission of handwriting and drawings by wireless telegraphy. An account of additional experiments by the method described in an earlier communication. A reproduction is given of a radio-

telephotogram sent across the Atlantic.—**Pierre Jolibois** and **Robert Bossuet**: The precipitation of uranyl nitrate by soda. The radioactivity of the precipitate. The first precipitate formed carries with it a considerable proportion of uranium-X. The oxide of uranium-X is less basic than uranium oxide.—**Max Gelo**: The absorption of iron by precipitates of manganese dioxide.—**Ch. Dufraisse** and **P. Gérard**: The action of alcohols on  $\alpha$ -bromobenzalacetophenone.—**Henri Longchambon**: Study of the tritoluminescence spectrum of saccharose. Previous work on this subject has led to the conclusion that the light given out when crystals of sugar are crushed is continuous. It has now been proved that the spectrum is discontinuous, and the bands observed correspond with the second positive band spectrum of nitrogen. The effect is probably due to a silent electrical discharge between two solid particles of sugar suddenly separated and charged electrically. This view is confirmed by the fact that when sugar is broken in a vessel containing air under reduced pressure (40 mm. to 1 mm. of mercury) the luminosity is much more intense.—**St. Jonec**: The distribution of the anthocyanidines in the coloured organs of plants.—**E. Wollman** and **M. Vagliano**: The influence of avitaminosis on lactation. A rat fed with food deprived of vitamins is incapable of supplying its young with the vitamins necessary for growth. Young rats, from the earliest days of their existence, can utilise vitamins of foreign origin (from yeast and butter).—**G. Mouriquand** and **P. Michel**: Auto-immunisation against deficiency diet.—**L. Panisset** and **J. Verge**: The "donneurs de sang" (horses providing blood for transfusion) in veterinary medicine. The transfusion of blood from one individual to another of the same species is known, in the case of man, to be attended with certain risks (agglutination, hemolysis). Laboratory experiments *in vitro* and also clinical practice show that these risks are very small with horses or with cattle.—**Jean Delphy**: *Gregarina Saururidis* and its host.—**W. R. Thompson**: The study of some simple cases of cyclic parasitism in entomophagous insects.—**C. Levaditi** and **S. Nicolau**: Vaccine and neoplasms.

## Official Publications Received.

The National Physical Laboratory. Report for the Year 1921. Pp. 207. (London: H.M. Stationery Office.) 6s. 6d. net.

The North of Scotland College of Agriculture. Guide to Experiments at Craibstone, 1922. Pp. 42. (Aberdeen.)

Report of the Director of the Royal Observatory, Hongkong, for the Year 1921. Pp. 17. (Hongkong.)

Canada. Department of Mines: Geological Survey. Summary Report, 1921. Part C: Geology and Mineral Resources of Rice Lake and Oiseau River Areas, Manitoba. By H. C. Cooke. Pp. 366. (Ottawa.)

Canada. Department of Mines: Geological Survey. Bulletin No. 34, Geological Series, No. 41: Physiography and Glacial Geology of Gaspe Peninsula, Quebec. By A. P. Coleman. Pp. 52. (Ottawa.)

Canada. Department of Mines: Victoria Memorial Museum. Bulletin No. 36, Biological Series, No. 8: Land Snails from the Canadian Rockies. By S. Stillman Berry. Pp. 19. Memoir 126, No. 4 Biological Series: A Botanical Exploration of the North Shore of the Gulf of St. Lawrence, including an Annotated List of the Species of Vascular Plants. By Harold St. John. Pp. iii+130. (Ottawa.)

Redogörelse för Skogsöverskottsstatistiska Verksamhet under Fyraårsperioden 1918-1921 jämte Förslag till Arbetsprogram: Summary of the Programme of the Swedish State Institute of Experimental Forestry for the period 1922-1926. (Meddelanden från Statens Skogsöverskottsanstalt, Häfte 19, Nr 1.) Pp. 123. (Stockholm: Centraltryckeriet.)

The Journal of the Institute of Metals. Edited by G. Shaw Scott. Vol. 27. Pp. viii+621+35 plates. (London: The Institute of Metals.) 31s. 6d. net.

Annual Report of the Board of Regents of the Smithsonian Institution showing the Operations, Expenditures, and Condition of the Institution for the Year ending June 30, 1920. (Publication 2622.) Pp. 704+plates. (Washington: Government Printing Office.)

University of Bristol. The Annual Report of the Agricultural and Horticultural Research Station (The National Fruit and Cider Institute), Long Ashton, Bristol, 1921. Pp. 160. (Bristol: The University.)

# NATURE

A WEEKLY ILLUSTRATED JOURNAL OF SCIENCE.

*"To the solid ground  
Of Nature trusts the mind which builds for aye."*—WORDSWORTH.

No. 2752, VOL. 110]

SATURDAY, JULY 29, 1922

[PRICE ONE SHILLING

Registered as a Newspaper at the General Post Office.]

[All Rights Reserved.]

## OPTICAL PROJECTION APPARATUS

for all classes of  
EDUCATIONAL WORK.

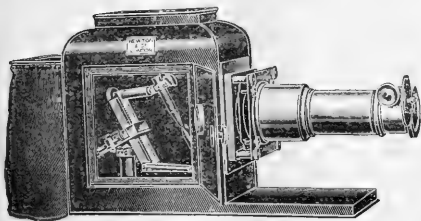

*Catalogue on application.*

**NEWTON & CO.,**

*Opticians to H.M. the King.*

72 WIGMORE STREET, LONDON, W.1.

## CHEMICALS

Analytical, Technical and A.R.

RECD. TRADE MARK

## APPARATUS

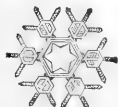

A SNOW CRYSTAL

Balances  
**BENCHES**

Fume Chambers, etc.,

for  
Chemical, Physical, and  
Technical Laboratories.

*Price Lists and Estimates on Application.*

## REYNOLDS & BRANSON, LTD.,

Contractors to the War Office, Admiralty and  
Egyptian Government, &c.

14 COMMERCIAL STREET, LEEDS.

**BAIRD & TATLOCK (LONDON) LTD.**

SCIENTIFIC INSTRUMENT MANUFACTURERS  
and LABORATORY FURNISHERS.



N/9283  
RESISTANCE BOX

Physical  
Apparatus  
for  
Schools  
and  
Colleges.

14 CROSS STREET HATTON GARDEN LONDON E.C.1

## BAROGRAPHS

Four rubber feet to the base  
— a self-adjusting pen arm—  
a supporting rod to the cover—  
these are some of the refinements  
on our Recording Barometers.  
Write for price list "B.3."

## NEGRETTI & ZAMBRA

38, HOLBORN VIADUCT, E.C.1.  
LONDON.

FACTORY HALF-MOON WORKS,  
BARNBURY.

## UNIVERSITY OF LONDON, KING'S COLLEGE.

### FACULTY OF ENGINEERING.

Complete COURSES of STUDY, extending over either three or four years, are arranged in

#### CIVIL, MECHANICAL, AND ELECTRICAL ENGINEERING

for the Engineering Degrees of the University of London, and for the Diploma and Certificate of the College.

The four years' Course provides, in addition to the academic training, opportunity for practical training in "Works."

#### HEADS OF DEPARTMENTS.

Professor G. COOK, D.Sc., A.M.Inst.C.E., A.M.I.Mech.E., Mechanical Engineering.  
 Professor A. H. JAMESON, M.Sc., M.Inst.C.E., Civil Engineering.  
 Professor E. WILSON, M.Inst.C.E., M.I.E.E. (Dean), Electrical Engineering.  
 Professor S. A. F. WHITE, M.A., Mathematics.  
 Professor G. H. JEFFERY, M.A., D.Sc., F.I.C., F.R.S., Chemistry.  
 Professor SAMUEL SMILES, O.B.E., D.Sc., F.I.C., F.R.S., Chemistry.  
 Professor A. J. ALLMAND, M.C., D.Sc., F.I.C., Chemistry.  
 Professor O. W. RICHARDSON, D.Sc., F.R.S., Physics.  
 Professor W. T. GORDON, D.Sc., F.R.S.E., Geology.

Considerable extensions have been made in the Engineering Department. These include a large additional Drawing-Office, Lecture-Room, and Laboratory for Hydraulics and Strength of Materials in the Civil and Mechanical Departments; and Research Rooms, including Wireless Telegraphy, in the Electrical Engineering Department. Large additions have been made to the equipment of the Laboratories in the three Departments for purposes of Teaching and Research.

There is a College Hostel and a large Athletic ground.  
 For full information apply to THE SECRETARY, King's College, Strand, W.C.2.

## THE ROYAL SOCIETY.

### FOULERTON RESEARCH PROFESSORSHIP.

Subject to candidates of sufficient distinction presenting themselves, the President and Council of the Royal Society of London propose to create a FOULERTON RESEARCH PROFESSORSHIP at a stipend of £1400 per annum, the duties of the holder being to conduct such original researches in Medicine or the contributory sciences, on lines approved by the President and Council, as shall be calculated to promote the discovery of the causes of disease and the relief of human suffering. The Professorship will be tenable in the first instance for five years, but may be extended for further periods of five years. Members of either sex are equally eligible.

### FOULERTON RESEARCH STUDENTSHIP.

Subject to candidates of sufficient merit presenting themselves, the President and Council of the Royal Society propose to create a FOULERTON RESEARCH STUDENTSHIP at a stipend of £700 per annum, the duties of the Student being to conduct researches in Medicine or the contributory sciences under the supervision and control of the Managing Committee, to whom he will be required to report from time to time. The Studentship will be tenable for three years, but may be renewed from year to year with a maximum total tenure of six years. Members of either sex are equally eligible.

Applications must reach the Royal Society not later than October 31, 1922. Further particulars can be obtained from the ASSISTANT-SECRETARY of the Royal Society, Burlington House, London, W.1.

## SCHOOL OF GARDENING AND NATURE STUDY.

CLAPHAM, near WORTHING.

Principals: Miss C. CRACKNELL, N.D. Hort., late of Swanley Horticultural College.  
 Miss G. COLEMAN.

PRACTICAL and THEORETICAL TRAINING in GARDENING: Fruit, Vegetable, and Flower Growing; Glasshouse and Frame Work; Course of two years; Poultry; Dairy Work; Bees. Preparation for R.H.S. Examinations.

## TO SCIENTISTS, RESEARCH STUDENTS, AND SCHOLARS.

### THE INTERNATIONAL BIBLIOGRAPHICAL SERVICE BUREAU

supplies complete Continental and American bibliographies on any scientific, literary, or medical subject. Medical work a speciality. Extracts made.

Headquarters: Vienna. English representative: "ALEXANDRIAN," 1A I. & 21, 1/2, Road, Earl's Court, S.W.5.

## THE RESEARCH ASSOCIATION OF BRITISH MOTOR AND ALLIED MANUFACTURERS.

PHYSICIST required as a Senior Research Assistant. Salary, £500-£600, according to qualifications. Apply by letter to the SECRETARY.

15 Bolton Road, Chiswick,  
London, W.4.

## UNIVERSITY COLLEGE OF SWANSEA

### (A CONSTITUENT COLLEGE OF THE UNIVERSITY OF WALES.)

#### Applied Science Departments.

##### METALLURGY.

Professor: C. A. EDWARDS, D.Sc. (Manchester).  
 Lecturer: H. I. COE, M.Sc. (Wales and Birmingham).  
 Assistant-Lecturers: A. L. NORBURY, M.Sc. (Manchester), L. B. PERLIT, B.Sc., A.R.S.M.

##### ENGINEERING.

Professor: FREDERIC BACON, M.A. (Cantab.), A.M.Inst.C.E., M.I.Mech.E., M.I.E.E.  
 Lecturer in Electrical Engineering: R. G. ISAACS, B.Sc. (Lond.), A.M.I.E.E.  
 Lecturer in Civil Engineering: To be appointed.  
 Demonstrator: J. SELWYN CASWELL.

The College offers a number of exceptional advantages to students who aim at entering upon professional careers in Metallurgy or Engineering. It is situated in the heart of an industrial area, which includes a large number of Works of very varied character, and presents an unrivalled variety of metallurgical practice. The manufacturers of the district, who contribute largely to the support of the College, give the staff and the students of the Applied Science Departments every access to the Works, and the Managers, Engineers, and Technical Officials co-operate with the Staff of the College in making visits to Works of practical educational value to the Students.

Courses of study are provided (1) for the B.Sc. Degree of the University of Wales in (a) Metallurgy, (b) Civil Engineering, (c) Mechanical Engineering, (d) Electrical Engineering; and (2) for Diplomas of the College in (a) Metallurgy, (b) Civil Engineering, (c) Mechanical Engineering, (e) Electrical Engineering.

Students who are not desirous of studying for degrees or diplomas may attend selected College Classes, provided they satisfy the authorities of the College that they are qualified to benefit by such classes.

Entrance Scholarships will be offered for competition in September 1922. Particulars concerning admission to the College, and of the Entrance Scholarships, may be obtained from the undersigned.

EDWIN DREW, Registrar.

University College,  
Singleton Park, Swansea.

## UNIVERSITY OF SYDNEY. NEW SOUTH WALES, AUSTRALIA.

### CHAIR OF ZOOLOGY.

Applications are invited for the above position. Salary (fixed), £1100 per annum, and £150 allowed for travelling expenses to Sydney from Europe. Duties commence March 1, 1923.

Further details of terms of appointment may be obtained from the undersigned, to whom applications (in sextuplicate), stating age and qualifications, accompanied by reference and copies of testimonials, should be sent not later than Thursday, August 31, 1922.

AGENT-GENERAL FOR NEW SOUTH WALES.

Australia House, Strand, London, W.C.2,  
July 3, 1922.

## EMPIRE COTTON GROWING CORPORATION

Applications are invited for the post of ASSISTANT FOR COTTON RESEARCH in St. Vincent (West Indies), from candidates suitably qualified in genetics and plant physiology with experience of practical agriculture. The duties will consist of genetics research on the cotton plant, and the researcher will work under the general direction of the Imperial Commissioner for Agriculture for the West Indies. Salary, £600 to £700 per annum according to qualifications, and free bachelor quarters. Applications must be made by letter not later than August 10 to THE SECRETARY, Empire Cotton Growing Corporation, Millbank House, Millbank, London, S.W.1, from whom further particulars may be obtained.

## ISLE OF WIGHT COUNTY EDUCATION COMMITTEE. SANDOWN SECONDARY SCHOOL.

The County Education Committee invite applications from Masters or Mistresses for the post of HEAD TEACHER of the above School.

The commencing salary will be the minimum rate laid down in paragraph 11 (1) of the Bathurst Secondary Scale.

Forms of application and further particulars can be obtained from the undersigned upon receipt of a stamped addressed envelope.

The last date for the receipt of applications will be Saturday, September 9, next.

H. J. JERVIS, M.A., Director of Education.  
County Hall, Newport, I.W.,  
July 21, 1922.





SATURDAY, JULY 29, 1922.

## CONTENTS.

	PAGE
The Cause of Rickets . . . . .	137
The Border Land of Tibet and Nepal. ( <i>Illustrated.</i> ) By H. H. G. A. . . . .	139
The Early Metal Ages in South America. By Henry Balfour . . . . .	141
A Monument to a Master Chemist. By Dr. E. F. Armstrong, F.R.S. . . . .	142
American General and Economic Geology . . . . .	143
Our Bookshelf . . . . .	145
Letters to the Editor:—	
The Intensity of X-ray Reflection.—Prof. W. L. Bragg, F.R.S., and R. W. James . . . . .	148
Geology and the Primitive State of the Earth.— Dr. Harold Jeffreys . . . . .	148
$\alpha$ -Particles as Detonators.—Dr. Horace H. Poole . Occurrence of a Crystalline Style in the American Slipper Limpet ( <i>Crepidula fornicata</i> ) and its Allies. —Dr. J. H. Orton . . . . .	149
Sense of Smell in Birds.—C. B. Williams . . . . .	149
The Skull of Sir Thomas Browne.—Sir Arthur Keith, F.R.S., and Prof. Karl Pearson, F.R.S. . . . .	149
Bloomsbury and the University of London. ( <i>Illustrated.</i> ) By T. Ll. Humberstone . . . . .	150
The Physiology of Life in the Andes. ( <i>Illustrated.</i> ) By J. Barcroft, C.B.E., F.R.S. . . . .	152
Obituary:—	
H. S. H. Prince Albert of Monaco. By Sir W. J. A. Herdman, F.R.S. . . . .	156
Current Topics and Events . . . . .	158
Our Astronomical Column . . . . .	160
Research Items . . . . .	161
Leicester Conference of the Museums Association . . . . .	163
The Arrangement and Motion of the Sidereal System . . . . .	163
The Oil Palm in French West Africa . . . . .	164
The French Dye Industry . . . . .	154
The Metallic State . . . . .	165
University and Educational Intelligence . . . . .	165
Calendar of Industrial Pioneers . . . . .	166
Societies and Academies . . . . .	167

Editorial and Publishing Offices:

MACMILLAN &amp; CO., LTD.,

ST. MARTIN'S STREET, LONDON, W.C.2.

Advertisements and business letters should be  
addressed to the Publishers.

Editorial communications to the Editor.

Telegraphic Address: PHUSIS, LONDON.

Telephone Number: GERRARD 8830.

## The Cause of Rickets.

SO much has been heard in recent times of rickets as a disease due to a deficiency of the fat-soluble vitamin A which promotes growth, that it is a good corrective to examine again the position of those observers who do not agree that the disease is essentially an "avitaminosis," as the French would say. An interesting survey of the work of the Glasgow school from this point of view is given by Dr. Leonard Findlay in the *Lancet* (April 29, 1922, vol. i. p. 825). He there reviews the variety of investigations which have been carried on for some 15 years by himself and his collaborators—clinical, experimental, and sociological—and comes finally to the conclusion that "confinement and defective hygiene are the most potent causes in the production of rickets." While opinions will differ as to whether this summary may not be too comprehensive, no one can fairly say that the facts which he adduces are compatible with a positive conclusion that rickets is due to a deficiency of fat-soluble A. It is fortunately no longer necessary to try to decide which of these two views is correct for, as so often happens, it is now pretty clear that both are right, and, which deserves less notice, that both are wrong. The two propositions are indeed not contradictory but complementary.

In the same journal (July 1, 1922, vol. ii. p. 7) appears a preliminary account by Dr. Chick and her colleagues of their observations on children in Vienna which goes far to reconcile and harmonise the two points of view. By very careful experiments they show clearly that under certain conditions rickets can be controlled by cod-liver oil, and it is legitimate to assume for the present that the active factor is fat-soluble vitamin A. They also show (1) that the well-known seasonal prevalence of rickets in the winter and early spring finds a rational explanation in the preventive and curative action of sunlight, which can be duplicated by rays from a mercury vapour quartz lamp, and (2) that under equal conditions of diet and environment the disease develops much more readily in children under six months of age than in those a little older, presumably in correlation with the more rapid rate of growth, as Mellanby found in his experiments on dogs. The occurrence of rickets is evidently conditioned by a number of circumstances, of which one or another may in any given case be the "cause" in the pragmatical sense that attention to it may give satisfactory prophylaxis or cure.

From the vast amount of clinical and experimental work on the subject which has appeared in the last two or three years it seems possible to disentangle a certain number of definite data. If conditions are otherwise

favourable, rickets may be encouraged (a) by defective diet, the deficiency being in the sense of (i.), too little fat-soluble A, (ii.) too little calcium and phosphate, (iii.) too little meat and too much bread; (b) by bodily confinement and lack of exercise or by rapid growth; or (c) by the absence of sunlight. Conversely, rickets may be ameliorated or cured by (a) giving plenty of fat-soluble vitamin in cod-liver oil or butter, avoiding too much cereal food, and (which is of experimental rather than practical importance) having a reasonable amount of calcium and phosphorus in the diet; (b) by encouraging metabolism by massage and electricity, or, which comes to the same thing, by being careful that the total intake of energy in the food is no more than is necessary; or (c) by exposing the skin to open sunlight or to sources still richer in ultra-violet light, such as mercury vapour lamps or metallic arcs.

Dr. Findlay rightly objects to any superficial conclusion from this array of circumstances that rickets has many causes. A disease of so definite and isolated a species must be held *prima facie* to have but one cause. What that *vera causa* is we do not know, but evidently if the various contingencies that have been enumerated can be reduced to some common factor, some progress will have been made in its discovery. In the analogous case of beri-beri it is known that the quantity of vitamin B which is required to avert the onset of polyneuritis in experimental pigeons is proportional to the quantity of carbohydrate in the diet. It seems likely that the quantity of vitamin A necessary to prevent or cure rickets varies similarly with the intake of other food. A full diet and rapid growth encourage its onset: a meagre stunting allowance is to some extent a preventive. The quality of the food is evidently also of importance: it must contain an adequate and balanced supply of the materials necessary for bone formation, and, though this is still obscure, the right kinds of proteid (animal rather than vegetable) and no large excess of carbohydrate. It also makes a difference whether the food absorbed into the economy is used for energy production or for storage and growth. Exercise, even that brought about by the irritation of the itch, according to Dr. John Mayo (1674), is antagonistic to rickets, and if the child cannot take it in the ordinary way massage and electrical stimulation may supply it.

It appears, therefore, that the amount of vitamin B which is necessary varies with the proportion or quantity of food which is not used for energy production; if all other conditions are as favourable as possible, the vitamin may with some children be reduced without ill results to amounts which appear to be very small by the available method of testing on growing rats: from which comes the conclusion that the vitamin

has not much to do with the ætiology of rickets. If, on the other hand, all or some of the other conditions are unfavourable, the quantity of vitamin—the abundance, e.g., of butter or cod-liver oil—may make all the difference between a healthy and a sick child: hence the conclusion that vitamin B is the most important factor. Even in respect of the necessary components of bone, the vitamin is quantitatively important. Rickets may be induced in rats by a deficiency of vitamin A and of calcium, but not by a deficiency of either substance alone. The vitamin in this case enables the growing tissues to make use of a concentration of calcium which otherwise they would be unable to utilise for bone formation. Such observations may in time elucidate the relative weight of the various factors of which at present it is known only that they are quantitatively related to one another.

To bring the influence of ultra-violet rays on the skin into this conception of the causation, or rather the contingency, of rickets, it is not difficult to believe that it acts by increasing general metabolism, in other words by giving exercise. It is known that inflammatory and sub-inflammatory processes in the skin may lead to the generation of substances which are absorbed into the circulation and affect the whole body, e.g. by increasing the susceptibility of the whole skin to the action of some local irritant. By some similar process, metabolism might easily be affected. It is also possible that vitamin A is developed in the skin under this form of stimulation, though the nocturnal and crepuscular habits of our pigmented hairy predecessors make it difficult to explain the phylogenetic history of the mechanism. Whatever the solution, the observation that rickets may be cured by short exposures to the mercury vapour lamp in hospital wards provides a welcome experimental confirmation and partial analysis of the sociological finding that the conditions of life in the dreadful tenement flats of Glasgow are *per se* conducive to the disease.

The question therefore "What is the cause of rickets?" is at present as insoluble as the problem "Is the tubercle bacillus the cause of tuberculosis?" The answer in both cases is that it depends on circumstances. In the latter case we have, however, reached the stage when we can say that tuberculosis is impossible without the tubercle bacillus: the bacillus has been identified as the ultimate limiting factor. That absence or deficiency of vitamin A occupies the same position in respect of rickets has yet to be shown. It seems likely that it does, but the demonstration has not been made that cod-liver oil will avert rickets when all other germane circumstances have been arranged to provoke it.

### The Border Land of Tibet and Nepal.

*Mount Everest: The Reconnaissance, 1921.* By Lieut.-Col. C. K. Howard Bury and other Members of the Mount Everest Expedition. Pp. xi + 356 + 33 plates + 3 maps. (London: E. Arnold and Co., 1922.) 25s. net.

THIS is a very attractive book with its wealth of beautiful illustrations, and the interest is great, whether told by Col. Howard Bury himself, or in the introduction by Col. Sir Francis Younghusband, by the surveyors—Major Morshhead, Major Wheeler, and Dr. Heron—by other members, Dr. Wollaston and Mr. L. Mallory. The latter's knowledge of the Alps makes his portion a valuable contribution. The description of the monasteries, the beautiful type of their architecture shown in photographs, will be new to many. Of the Lamas themselves and their orderly system of government we find the same from one end of Tibet to the other. This will interest and prove instructive; readers will find they are not ignorant savages, but a people highly advanced in arts and education, and in many respects far more practical, united, and sensible than we are. Of course it is not new; much can be seen in Ladak and in the fine monastery of Himis near Leh, but what is new is the degree to which the tameness of wild animals and birds has been brought by the Buddhists living under the shadow of Mount Everest, markedly by those leading a hermit life in the Rongbuk Valley.

There are some striking lines in chapter 12, p. 183, where Mr. Mallory describes his feelings on the first good view of Everest, feelings shared in by Mr. G. H. Bullock, on their sighting it at 57 miles distance from Shiling, west of Tinki, their first impressions of what was before them. I was struck by, and like, what Col. Howard Bury says on "Back to Civilisation," p. 176. The right type of traveller is shown here:

"There was sorrow in our hearts, however, at parting with the friendly and hospitable folk whom we had encountered, and at leaving behind us the familiar landscapes with the transparent pale blue atmosphere that is so hard to describe and the distant views of range upon range of snowy mountains often reflected in the calm waters of some blue coloured lake. The attractions of Tibet may yet be strong enough to draw us back again once more."

It is very disappointing to read in the *Geographical Journal* for May, p. 380, that "No Survey of India party is to go this year, and that Dr. Heron of the Geological Survey has not been allowed by the political authorities to continue his geological work." This may possibly be got over, but I fear that what I said in my article in this journal last year on our successful entry into Tibet, quoting the president of the Royal

Geographical Society, "Our geography of it must be complete," may not be realised.

These are investigations of true interest and value in connexion with the history of the Himalayan Range, the combining of accurate topography with knowledge of the rocks, so that a formation, say like that of the Ladak Range, can be traced mile after mile for a considerable distance, defining the age of the rocks both on the north and south of it.

The climbing of Mount Everest, on the other hand, is of secondary importance compared to what will be lost by political exigency, partly because "there was some little difficulty last year about the disturbance of the dragons that live under the sacred mountains" (quoting from the *Geographical Journal*, May 1922, p. 380). As a member of the Bhutan Mission in 1863-64, I remember what unreasonable, unexpected difficulties they will throw on the traveller going to any particular peak, or in any particular direction.

The past year's work, so well recorded in this book, has given us an insight into the geology and topography of the great peak. We know of the many valleys descending from it, towards the northern Tibetan side, and the type of the glaciers. It is lamentable to be told that Dr. Heron will not be able to complete his survey of the metamorphosed sedimentaries and associated granites, even on the limited slopes above the Chang La, which this year's expedition will reach, for there would be much detail for Dr. Heron to observe, and whether the "Daling Series" extends thus far.

I draw a line between climbing and mountaineering. There is a charm in the first, similar to that felt in the rigging of a ship by every sailor when he ascends to the main truck or lays out on a yard in a stiff breeze—there is a spice of danger in it. The second—and Mallory comes in here—demands a period of apprenticeship to gain that eye for ground which tells the surveyor where he can go, where he cannot, and the time it will take him to get over any particular section of country. Mountaineering is the highest form of athletic exercise that can be conceived; mind and knowledge enter into it.

I have long doubted the possibility of reaching the summit of Mount Everest by several thousand feet. What is the possible height attainable only those who have been on its side can guess. It is now being solved. I am guided by past experience at much lower elevations, less than 21,000 feet, but at a much higher latitude in Kashmir territory. There are so many uncertain factors, such as the impossibility of waiting for any length of time for a change of weather at the highest camp; strength of wind; cloud and snow and mountain sickness, which will prostrate a whole party at even 19,000 feet (Baltistan and Ladak).

A few remarks may be made on what there is to do. Accurate comparison should be made between the very typical glaciers of this far southern section of the Himalayan range and those in Kashmir territory and the Alps, on both of which much has been written. The accompanying illustration (Fig. 1) shows the rugged pinnacled surface, caused by difference in temperature between 28° latitude and that of Kashmir some 6° farther north, where the accumulation of both snow and moraine is so similar to that in the Alps. Around

Bhutan and on the Assam Range, with the elevation of which Everest is closely connected. Since late Pliocene time enormous disturbance and crushing on the Tibetan plateau has taken place, disturbance well displayed in the Naga Hills, on the Burreil range, where the whole thickness of the Tertiary rocks, from the base upwards, is seen elevated to 10,000 feet, resting unconformably on a much older formation. How much and how often has the course of the Arun altered, and with it the Tsauspu, in that, geologically



FIG. 1.—Mount Everest from the Rongbuk Glacier, nine miles north-west.  
From "Mount Everest" (slightly reduced in width from the illustration facing p. 214).

Mount Everest all is changed; its height and isolation alter all the usual conditions, even those of denudation. It is desirable to know the thickness of the glaciers, the stratification, rate of motion, how far the moraines extend, and to what extent rocks *in situ* show the effects of past glaciation. Among the members of this very large expedition some should take such observations and fewer be engaged in finding what height a man can reach with or without oxygen.

The extent of the moraines at the base of Mount Everest tell something of its history. They would be the same age approximately as those I have observed farther east on the south face of the Himalaya in

speaking, short lapse of time? Mr. Mallory describes this basal area and the surface of the Rongbuk Glacier, comparing it with his knowledge of the Alps. I am led to quote him (p. 192): "The glacier is prostrate, not a part of the mountain; not even a pediment, merely a floor footing the high walls. At the end of the valley and above the glacier Everest rises not so much a peak as a prodigious mountain mass." The party—put at 12 Europeans, 500 mule-loads, with number of coolies unknown—is to me, who worked long ago, huge, and out of all proportion to what has to be achieved, particularly as the first year's work has been so well told, the survey and geological work

so well done. The oxygen apparatus had much better have been left out, and experiments made on some more accessible peak. Never yet used under natural conditions at any elevation, it is complicated, and as four bottles weigh 32 lbs., impossible to work, for it seems to me the surveyor or climber carrying it would be unable to use his eyes or observe anything at the most critical time and under the most critical conditions.

I conclude with some remarks on the nomenclature of peaks. In the pages of the book and on Map 2, a large-scale one of Mt. Everest, constructed at the Royal Geographical Society, are the names Pumori, Ri-Ring, etc. In the May number of the *Alpine Journal* these, eleven in number, are explained (p. 228) in a contribution by Mr. Arthur R. Hinks, secretary of the R.G.S. They are all fictitious, and after all that has been written on the subject of nomenclatures I cannot too strongly condemn their creation, although they have had the criticism of Sir Charles Bell. Henceforward it will be no longer possible to distinguish between a *bona fide* Tibetan name and these inventions, unless as is adopted in natural history, the name of a species is followed by the name of its describer. The English names of Conway, Bullock Workman, and Dr. de Filippi, such as "Ogre Peak," "Mitre Peak," "The Bride," etc., are of a higher inoffensive order, and I for one see no reason why they should not be accepted. Will these new-coined names please the Tibetans, lay or sacerdotal? They may possibly give offence. Should we as a nation be pleased to see some foreign power mapping this country and giving names to our hills and valleys? I now come to the last name assigned to Mount Everest, "Chomo Lungma." It is not a happy one for a peak though quite correct in the passport issued by the Dalai Lama's Prime Minister, and very applicable to the country, a series of valleys round the great peak, which the Expedition was to work in. Lungma and Lungpa is a common name for a valley from Scardo eastward, and on Sheet 29A, N.E. of part of Baltistan and Little Tibet will be found a similar name, "Chogo Loongma," for the great glacier valley which ends at Arundo. Substitute "Chomo," feminine prefix (godness) for "chogo" (large), there is a close resemblance, but neither is applicable to the summit of a mountain.

I am glad the Survey of India did not rush at the discovery of this name and adopt it. Mallory thus records on p. 225: "In the Sahib's tent that night there took place a long and fragmentary conversation with the headman, our sirdar acting as interpreter. We gained one piece of information: there were two chomolungmas," that is, valleys. Every valley has its name in Tibet, where they go with their flocks and herds, but peaks are not so universally noticed and distinguished. While the R.G.S. is publishing on maps

new names for Himalayan peaks, I notice comparison with Peak K<sub>2</sub> occurs on p. 309. This, the second highest peak in the Himalaya, received the name of Godwin-Austen. At a meeting of the Royal Geographical Society, when Lieut. Younghusband read his paper, "From China through Tibet to Kashmir," I was present, and pointed out, on a large-scale plan I had prepared, the great size of the Baltoro Glacier and the position of the great peak near the source. Then followed the proposal of General J. T. Walker, R.E., the late Surveyor-General of India, under whom I had served, seconded by Sir Henry Rawlinson, president, in the chair, put to the meeting and carried unanimously. It was a great honour, an unexpected recognition of my survey work, and was deemed worthy of notice, appearing in a short time in the "Times Atlas" and in a German one. By degrees the R.G.S. has discarded my name; this book does the same; geographical record is wiped out, and leaves me to regret I was present that evening. The Indian Survey, carrying out rules of their own, correctly recognise no other name than Mount Everest; for the rest they must be of true native origin. H. H. G.-A.

### The Early Metal Ages in South America.

*The Copper and Bronze Ages of South America.* By Erland Nordenskiöld. (Comparative Ethnographical Studies, 4.) Pp. viii+197. (London: Oxford University Press, 1921.) 18s. 6d. net.

THERE has long been felt the want of a general summary of information relative to the employment of copper and bronze in South America, and Dr. Erland Nordenskiöld's volume will be welcomed as, to a great extent, filling the gap. In about 200 pages he has brought together a considerable mass of detailed information derived from the historical record, from representations of metal objects on textiles, pottery, etc., and from the actual implements and ornaments of copper and bronze. He discusses the problem from a variety of points of view, each chapter dealing with a particular line of inquiry.

The chronological horizons of S. American antiquities are as yet, unfortunately, insufficiently defined, and much spade-work will be required before the sequence of cultures and their relationship to one another can satisfactorily be established. The author, in dealing with this aspect of the inquiry, has made use of such evidence as is to hand and offers deductions which are often very suggestive, especially when the chronological evidence is correlated with the data derived from the study of geographical distribution of types, to which Dr. Nordenskiöld has devoted special attention.

Perhaps the most valuable portion of the present volume is that which is concerned with the chemical analyses of the metal objects. A considerable number of analyses of implements, weapons, and ornaments, the basic material of which is copper, is now available, and comparisons can be made of the percentages of tin combined with copper to yield different qualities of bronze. From the data supplied it will be seen that in the New World bronze objects the proportion of tin to copper varies exceedingly. In some instances it is so small as to make it doubtful whether the alloy can be intentional; and, in such cases, it may, perhaps, be legitimate to include the objects in the category of "pure copper." In others an unusually high percentage of tin is revealed (55-60 per cent. having been recorded by Ambrosetti in one chisel), though frequently it is the ornamental objects which contain a high proportion of tin. As Dr. Nordenskiöld points out, from the results of experiment, copper with a slight admixture of tin can be hardened effectually by hammering. In fact, for the manufacture of implements designed for hard usage (cutting tools, etc.) a relatively low percentage of the alloy, combined with the process of compacting the metal by hammering, seems to give the most satisfactory results. The hardness of various objects of copper and bronze was tested experimentally with a Brinell press, and the tests were applied to different parts of the same implement, the results showing that the edge was hardened more than the rest, as might be expected.

It is clear from the capriciously variable percentages of tin that the alloying of copper with this metal was not fully understood, and that the metallurgy of bronze was still for the most part in an experimental stage in South America.

The author endeavours to prove that throughout the territory of the Inca empire the Bronze-age was preceded by an age of pure copper. He makes out an interesting case, but this point can be settled finally only by stratigraphical evidence. Much of the argument is based upon typological classification and geographical distribution of types, which, together with analyses of the metals, form a powerful combination in suggesting sequences, though they cannot prove actual chronological successions.

An interesting typological sequence is afforded by certain socket axe-blades of copper, in which the decorative treatment preserves the memory of an earlier method of hafting, by means of a collar of stitched raw-hide or leather. The form of the leather collar, which suggested the socket in this type of axe, and also the thong-stitches, are realistically represented on the later copper blades, although the latter were entirely of metal and cast in one piece.

The book has suffered somewhat at the hands of both translator and printer. Several sentences are very obscure in their meaning, and misprints and other blemishes are unduly abundant. Such an expression as "bronze (pure copper)" surely should not occur in a treatise which aims at differentiating between the alloyed and the pure metal. This expression occurs more than once and tends to obscure the issue and weaken the argument.

In spite, however, of the avoidable blemishes which occur in this translated version, the book is of real value and throws light upon a very interesting archaeological problem. The volume is profusely illustrated, though the figures are of unequal merit, and contains maps and tables which are very helpful. There is also a bibliography.

HENRY BALFOUR.

### A Monument to a Master Chemist.

*Untersuchungen über Kohlenhydrate und Fermente II.* (1908-1919). Von Emil Fischer. Herausgegeben von M. Bergmann. Pp. ix+534. (Berlin: J. Springer, 1922.) Germany, 186 marks; England, 22s. 6d.

IT is an accepted fact in art and literature that, apart from the vagaries of fashion, only a future generation can properly assess the ultimate fame of artist or author. This is no doubt equally true in science, yet we are already sure that time will only serve to enhance the reputation of Emil Fischer. The remarkable official account of his life and work, written for the German Chemical Society by Kurt Hoesch, and the biographical fragment "Aus meinem Leben" left by Fischer himself, afford a unique store of material: when properly digested in this country by those competent to understand it, this should make it possible to obtain a clear view of his personality and attainments which will be free from the natural patriotic bias of his own countrymen.

During his lifetime Fischer, who was not without a characteristic strain of personal vanity, issued in book form reprints of his work on the sugars, proteins, purins, and tannins, including in the first papers published up to the end of 1908. Dr. M. Bergmann, a very loyal fellow-worker, has now collected the later sugar papers from 1908 onwards. To workers in this field, the advantage of possessing these volumes is very great, and science owes a debt of gratitude to Dr. Bergmann for completing them.

The sugars were Fischer's first love, though not the subject of his earliest work; to his work with phenylhydrazine he owed the chronic illness which had so great an effect on his daily life, causing him for a time to abandon their study, first for that of the de-

rivatives of purin—the mother substance of uric acid—and later of the proteins, thereby opening the door to almost a new branch of organic and physiological chemistry. Even in 1908, when he compiled the first set of reprints of his sugar work, he expressed the fear that this sensitiveness to phenylhydrazine would prevent him from taking any further active part in developing the chemistry of the sugars. Fortunately for posterity the old love proved too strong, and he returned again and again to the fray, the result being that forty-six additional essays chronicle the work achieved.

The writer had the good fortune to come under Fischer's tuition at the time of the opening of the new chemical laboratories in the Hessische Strasse in Berlin, and to be intimately associated with him during nearly three years, carrying out sugar inquiry under his inspiration, although at this time all other workers in the laboratory were busily engaged in the early stages of the great investigation on amino acids and proteins. Viewed from the perspective of twenty years later, it would seem that Fischer was already at that time a tired man, feeling both the strain of the work involved in obtaining and designing the new laboratory and the distraction caused by the heavy burden of official duties, which he never relished but could not avoid. Hoesch now throws much light on the events behind the scenes just before this period, as the provision of the new laboratory, made the first condition of Fischer's going from Wurzburg to Berlin, eventually took seven and a half years. His account includes the statement that at one time Fischer even seriously considered leaving Berlin and going to Bonn.

Apparently from the time he came to Berlin, as successor to Hoffmann, Fischer lived only for his work, and withdrew more and more within himself as the years passed. A widower, with his sons still young, he had no one to draw him out of himself in private life; he seemed to lose the power of unbending to his associates, although he was worshipped by his laboratory companions.

Having achieved the first synthesis of a natural sugar, glucose, Fischer's greatest ambition was to make ordinary cane sugar in the laboratory, and in 1900 this problem was again attacked with all the resources of the new laboratory. At first some measure of success was attained, as complex sugars (disaccharides) were obtained, identical or isomeric with some of the natural materials. The problem of the synthesis of cane sugar itself defied solution, however, and a measure of the difficulty of the subject is afforded by the fact that to-day, twenty years later, we are apparently no nearer success, in spite of the great progress made in other sections of carbohydrate chemistry.

The difficulties of synthesising natural and artificial glucosides were fully mastered, nearly half the papers published since 1908 dealing with this field of inquiry. These include the recognition of a third form of methylglucoside, the existence of which was concurrently demonstrated by Irvine in this country. This form, which apparently contains a  $\gamma$ -oxide ring, is highly active, and according to later work of Haworth, it may be the form in which the fructose molecule is present in cane sugar, for which Haworth accordingly suggested a new formula. The writer is not aware that Fischer expressed his views anywhere as to the correctness of Haworth's work; it cannot but have inspired him to renewed experimental effort to effect the much-desired synthesis.

In a dozen of the later papers are described results of the investigation of the acyl derivatives of the sugars, while a like number deal with mutations within the sugar molecule leading to the formation of substances such as glugal. The results serve to show that the chemist has still much to learn about this remarkable group; but they are too complex to be considered here.

Fischer's early work on enzymes is an acknowledged classic contribution to biological science. He returns to the subject in the last paper in this collection, dated July 14, 1919, a day before his death: this contains additional data for the discussion of the all-important question of the influence of the structure of  $\beta$ -glucosides on the activity of emulsin. It is written in Fischer's usual simple style—he used to dictate his papers while moving about the room in a very restless state—and shows how to the very end he retained his clarity of mind. A future generation alone can decide whether he should not be regarded as the greatest organic chemist the world has yet known.

E. F. ARMSTRONG.

### American General and Economic Geology.

*A Text-book of Geology.* By Prof. A. W. Grabau. In two parts. Part I.: General Geology. Pp. xviii+864. Part II.: Historical Geology. Pp. viii+976. (London: G. G. Harrap and Co., Ltd., n.d.) 64s. net, two vols.

*The Economic Aspects of Geology.* By C. K. Leith. Pp. xvi+457. (London: Constable and Co., Ltd., 1922.) 18s.

(1) **P**ROF. AMADEUS GRABAU, who is now professor of palæontology in the University of Peking and palæontologist to the Geological Survey of China, is the author of several excellent American geological text-books, and his new "Text-book of

Geology," in two volumes—one with the sub-title "General Geology," and the other with that of "Historical Geology"—supports his reputation. His work is marked by a logical arrangement of his material and a clear and interesting statement of the main problems. His teaching has been exceptionally wide in its range, as he was first lecturer in mineralogy at Tufts College, then professor of mineralogy and geology at the Rensselaer Institute, and afterwards professor of palæontology in Columbia University, New York. He has therefore had to teach both the physical and biological sides of geology, and he writes on both with sound knowledge and judgment.

The course of study Prof. Grabau recommends is to begin with the necessary elements of chemistry and mineralogy; then pass to the igneous rocks and volcanic action; next to take the "aqueous rocks"—which he limits to those formed as chemical precipitates, excluding those due to the mechanical action of water—and the organic rocks. Then follows the examination of the processes of erosion by wind, water, and ice, and by organic agencies; and after this work has been dealt with he proceeds to their products, the clastic rocks. The materials of the earth's crust having been studied, the course proceeds to the deformation of the rocks of the earth's crust by fold and fault, and to metamorphism and the rocks made by it, and concludes with the sculpturing of the earth's surface. This scheme, according to Prof. Grabau, is unusual in America, the physiographic section of the subject being usually taken first, but though that arrangement has no doubt great advantages in secondary schools, and in the popular presentation of geology, the author's course, beginning with the primary rocks and their constituents, seems to be the most logical for advanced students, and is adopted in some British universities.

The second volume deals with historical geology, and is the section in which the author's previous work renders his opinions of most interest and weight.

One striking feature of the book is its wealth of illustrations, which in the two volumes number 1980. Some of the most original are diagrammatic sections explaining the migrations of faunas, and they show that colonies have often played an important part, though not on the lines of the hypotheses which led to this process having been so long held in well-justified distrust.

One interest of such a general text-book is its evidence as to progress towards international agreement in terminology and theory. Prof. Grabau's classification of the pre-Cambrian rocks shows that their nomenclature is still chaotic. In the names of the geological systems he regretfully uses the adjectival

ending of "ian," as in Cambrian, as a concession, but he thinks the ending in "ic," such as "Cambric" will ultimately be adopted. He quotes the use of the term *caldera* for an explosion crater like Krakatoa, and uses the term *sink* for a hollow due to subsidence for which *caldera*, the Spanish word, or its English equivalent, *cauldron*, has prior right. His chapter on vulcanism is illustrated by an excellent map of its distribution, but the Cameroons volcano should not be entered as extinct. The chapter on petrology makes no use of the American system, and the author's conservative classification will probably be found generally convenient for students of the standard for which the book is intended. The view that the temperature of the centre of the earth may be 200,000° or 350,000° F. is far in excess of the more moderate temperature suggested by the probable high thermal conductivity of the barysphere.

The author discusses the cause of former glaciations, and considers that none of the theories is wholly satisfactory. He objects to the theories based on variations in composition of the atmosphere, on the ground that their effects should be world-wide, whereas the glaciations have been local. Apparently he seems most disposed towards a theory of the shifting of the poles, though recognising the weight of the mathematical objections. He gives a diagram showing how the movements of the North Pole into Greenland would explain the glaciation in North America and north-western Europe combined with the contemporary freedom of Asia from ice. As a palæontologist taking especial interest in historical geology, his views on the changes and positions of the ocean are of weight. He admits great movements of the seas, but considers that in the Palæozoic period both the Atlantic and the Pacific were shallow oceans; he represents most of the Atlantic as having been occupied by sea in the Cambrian. He discusses at some length prehistoric man, and adopts dates in years for him as if they were well established; but he is more cautious in his reference to Piltown man than some of his co-patriots when dealing with the possibility of the skull and the jaw belonging to the same individual.

(2) Mr. C. K. Leith's book on the economic aspects of geology contains many features of special interest. The central part of the book consists of brief descriptions of the chief ores and economic minerals, of their industrial uses, geological features, and mode of formation. The terseness of the descriptions makes them all the more convenient for those who desire a synopsis of the classification and formation of the chief economic minerals. The classification places pyrites amongst the group of fertilisers. This unusual arrangement is due to pyrites being largely used for



sulphuric acid in the manufacture of superphosphate. The book discusses some general problems which are not usually dealt with in geological text-books; thus there is a chapter on the world production of minerals, the capital value of the mineral reserves, and the political and commercial control of minerals. The last chapters deal with the relation of the geologist to the exploration and development of mineral deposits, the valuation and taxation of minerals, and mining law.

The discussion on this question includes the author's opinion of the much controverted Apex Law, wherein the mining laws of the United States and Rhodesia differ from those of the rest of the world. Mr. Leith says of the American geologists and engineers that "almost to a man they favour either modification or repeal of the law"; but he recognises that as it has been in force for 50 years, so large a body of vested interests has been established under it that it would now be difficult to make serious changes in it. He remarks on the objections to the present system of the use of expert evidence in law courts and the apparent advantage of selection of experts by the Court instead of by the contending parties; but he thinks the present system on the whole preferable, as the Court might find a sound selection impossible. The intense competition in such inquiries leads to the most intensive study of the problems. The author considers that few scientific treatises on economic geology contain facts better established than the reports of the great cases that have been rendered necessary in America by the imperfections of the Apex Law.

The author's conclusions as to the conservation of mineral resources are that little is to be feared from the actual shortage of supplies, but that the difficulties will arise in their extraction and distribution at a rate adequate to meet the future demand. He explains the use of geology in the late war and discusses the international problems based on mineral resources, which he represents as now in such confusion that it will take the combined efforts of the various governments many years to bring them into order. He says the entire European coal situation is in a state of chaos, and that, "unless there is a miraculous recovery and development of Germany's coal industry, impossible conditions have been imposed."

The volume concludes with chapters on the training of the economic geologist and on the ethics of his profession. The author recommends that the intensive study of geology should be a post-graduate course, that the universities should not give degrees in economic geology, but should leave the maintenance of a high standard, both of knowledge and conduct, to the professional societies connected with geology and mining.

## Our Bookshelf.

*British Labour: Replacement and Conciliation 1914-21: Being the Result of Conferences and Investigations by Committees of Section F of the British Association.* Part 1, on Replacement, Co-ordinated and Revised by Miss L. Grier and Miss A. Ashley; Part 2, on Conciliation, Edited by A. W. Kirkaldy. Pp. xxxv + 266. (London: Sir Isaac Pitman and Sons, Ltd., 1921.) 10s. 6d. net.

An attempt has been made in the volume under notice to "sum up and co-ordinate" the various reports, issued between 1915 and 1920 by the Economic Section of the British Association, and relating to problems of labour during war-time.

In the first part of the volume, Miss Grier and Miss Ashley have succeeded admirably in their rather difficult work of collation, and the result is to present in small compass a concise history of the industrial adventure of women during the period of the war. The outlines of the story are by now sufficiently familiar: the value of the present contribution lies in the rich store of material, partly statistical, which it offers, and in the conclusions it reaches regarding the future of women in industry. The moral of the story is that while war-time experience has left women more ready to offer their services in production, there has been little permanent modification of industry which would make it possible to utilise those services.

Part 2 of the volume, dealing with conciliation in British Labour, 1914-1921, is somewhat inchoate. It is practically a reprint of reports on the promotion of industrial harmony and on industrial unrest, which had already been published elsewhere, and there is little evidence of selection from the papers and speeches which make up the original reports. Some excision and co-ordination would have added to the permanent value of this section.

The last forty pages of the volume contain a sympathetic discussion of works committees by Mr. C. G. Renold, who deals, with much breadth of vision, with the problems of industrial management involved in the growth of these committees.

*Royal Society. Reports of the Grain Pests (War) Committee.* Nos. 1 to 10 (in 1 volume). Pp. 23 + 48 (+ 11 plates) + 18 + 20 + 10 + 51 + 52 + 28 (+ 11 plates) + 52 + 16. (London: Harrison and Sons, 1918-1921.)

THE Grain Pests (War) Committee was appointed by the Council of the Royal Society in June 1916, as the result of correspondence with the Board of Agriculture, in which the Board requested the Royal Society to appoint a committee "in relation to the damage done to grain by insects." When established, the committee at once took very active measures to carry out the work allotted to it, and published the results of the investigations which it initiated in a series of valuable reports. Most of the latter have already been noticed in our pages and need no further comment. These reports have now been issued in book form, together with a final brochure (Oct. 1920), drawn up by the chairman, Prof. W. A. Herdman, who has summarised the results of the researches and puts forward certain

recommendations as to future work. The findings of the committee have shown clearly that the whole subject of grain pests is one of great importance to the Empire, and it is recommended that the State should assume a general responsibility for the continuance of the investigations. It is obvious that, if the work is to be placed on a permanent basis, it must be sufficiently provided for in order that it may be carried to its logical conclusion—the practical control of grain pests. The recommendations made for the provision of a nucleus organisation do not involve any large expenditure of money and, in view of the great importance of the conservation of food-stuffs, it is earnestly hoped that the Government will see its way to establish the work along lines suggested by this committee.

A. D. IMMS.

*Among Primitive Peoples in Borneo: A Description of the Lives, Habits and Customs of the Piratical Head-Hunters of North Borneo.* By I. H. Evans. Pp. 318. (London: Seeley, Service and Co., Ltd., 1922.) 21s. net.

The part of Borneo described by Mr. Evans is that which is under the control of the British North Borneo Company, and the peoples with whom he deals are three in number: the Dusuns, an Indonesian people speaking a Malayo-Polynesian language, who inhabit the interior; and the Bajaus and Illanuns, immigrants of Proto-Malayan stock who live on the coast. Mr. Evans is a careful observer, and his experience as an official of the company enables him to speak with authority. On many points he is able to correct or supplement our previous information. The peoples he describes present marked contrasts, both in temperament and in culture. The Dusun is an agriculturist, in the main industrious, living in independent village-communities, each under a headman. In religious belief he is an animist, and has a strong and abiding faith in omens. The coastal peoples, on the other hand, are indolent and inveterate gamblers, who, now that their former chief industry—piracy—has been suppressed, earn their living from the sea. They are Mahomedans, but lax, and their religious beliefs embody many survivals of primitive beliefs, of which, unfortunately, Mr. Evans had opportunity to collect only a few examples.

*The Island of Roses and her Eleven Sisters: or, the Dodecanese from the Earliest Time down to the Present Day.* By Dr. Michael D. Volonakis. Pp. xxv + 438. (London: Macmillan and Co. Ltd., 1922.) 40s. net.

In this volume the author gives an account, both historical and geographical, of the twelve islands lying off the western extremity of Asia Minor, for which the term "Dodecanese" has become current since the Italo-Turkish war. Of these, the most important is the island of Rhodes, and to English readers the names of others, notably Patmos, associated with St. John and the Book of Revelations, and Cos, the home of Hippocrates, will be equally familiar. The author, himself a native of the Dodecanese, relies mainly upon literary sources, but has supplemented these by the evidence of archaeology and numismatics, while his intimate local knowledge has proved invaluable in

elucidating his authorities. Owing to the isolation of their insular position, the inhabitants, while taking part in times of crisis in the affairs of mainland Greece, have kept their institutions practically intact from a remote period, notwithstanding successive waves of invasion, and subjection to the Knights of St. John, the Turk and the Italian. Hence this description of the islands has a peculiar value, and the author's fuller account of their archaeology and culture here promised will be awaited with interest. The book is exceedingly well illustrated by numerous photographs.

*The Machinery of the Mind.* By Violet M. Firth. Pp. 95. (London: G. Allen and Unwin, Ltd., 1922.) 3s. 6d. net.

It is stated by the author that this volume is for the edification of those who have neither the time nor the training necessary for the study of standard texts.

Whether such readers will be in the position, at the end of its perusal, to apply its generalisation to the interpretation of their own problems, or be inspired to continue the subject, is doubtful. In less than one hundred pages the author disposes of some of the most fundamental and debatable problems of modern psychology, but naturally there is no clue to their debatable character. It may be possible to compress the general truths of some sciences into a few pages, but none of the biological sciences are in that position, and psychology least of all. In a few lines the technical terms, sensation, percepts, concepts, images are used but not explained, while complex is used in two different senses. Analogy is useful in its place, but is very much over-used here; nor is it scientifically sound to give as evidence in a later chapter what has been merely asserted in an earlier one. In short this book is little more than an expanded dictionary of some frequently used psychological terms with the drawback that the order is not alphabetical.

*Human Traits and their Social Significance.* By Dr. Irwin Edman. Pp. xii + 467. (London: Constable and Co., Ltd., n.d.) 15s.

THE work under notice is designed to serve as a general introduction to the problems of contemporary civilisation. The author feels that in attempting to interpret the conditions of life under which we live the psychological point of view is too frequently overlooked, and yet it is most important. Following Dr. McDougall and Prof. Thorndike, he describes the fundamental activities which are man's endowment, his primitive instincts, their environmental modification and development, the individual difference in endowment and the part played by language. While emphasising the innate character of many of man's actions and aims, the author realises that there is also in man the power to reason and to put before himself ideals which he considers desirable; such ideals when embodied in social customs, institutions, and speech become powerful motives.

The style is clear and the whole book is easy to read and should prove of value to the historian, economist, and the student interested in the complexities of life. The subdivision of each chapter, however, into paragraphs with a heading in heavy type seems unnecessary, and is a hindrance rather than a help.

*Problèmes et exercices d'électricité générale.* Par Prof. P. Janet. Pp. vii+254. (Paris: Gauthier-Villars et Cie, 1921.)

PROF. JANET gives an interesting collection of problems which have been set in the entrance examinations for the Higher School of Electricity in Paris. Many of the problems are novel, and in some cases it is shown how the solution can be obtained by several different mathematical methods. The examples are purely theoretical, so exact solutions can be given. They are expressed in nearly every case by algebraical formulæ, numerical illustrations being left to the student. The English reader will find the latter part of the book very instructive, as the author frames his problems so as to take into account mechanical as well as electrical considerations. For example, the instantaneous values of the currents depend on the moments of inertia of the moving parts of the machines as well as on the inductances of the circuits. We hope this innovation will be followed in English text-books. The students are supposed to have a thorough knowledge of electrical principles and to be familiar with the calculus. We can recommend this book to teachers. A. R.

*Thought-Coin.* By Bart Kennedy. Pp. x+219. (London: W. Rider and Son, Ltd., 1921.) 5s. net.

THE title gives no clue to the contents of this book. It is not, as might be imagined, one of those pseudo-scientific works urging a one-sided belief in the all potency of thought, nor is it a psychological treatise on thought-processes. It is an attempt to consider some of the problems of life, such as dreams, consciousness, grouping, sex, etc., not as abstractions but as living realities; it is a frank acceptance of facts as against the "oughts" and "ifs" of so many writers, and so far is more truly scientific than some of the more apparently scientific books. The author surveys the universe with the vision of the seer, and gives to problems which are so often treated in isolation the background of relation to the universe. All life is for him an ever provocative mystery. He writes with a penetrating imagination, but imagination controlled and vitalised by the teaching of science. It is interesting to read scientific problems expressed in terms of imaginative literature.

*The Evolution of Consciousness.* By A. W. Tilby. Pp. 256. (London: T. Fisher Unwin, Ltd., 1922.) 15s. net.

MR. TILBY writes with a vivacity and humour which make his book exceedingly pleasant reading. It contains no original research, but it is exceptionally well-informed. The idea is outwardly very like that of Bergson's creative evolution, and may have been suggested by it—that consciousness in every form, instinctive and intellectual, is a product of the evolution of life and utilitarian in its purpose. There is an essential difference, however, in the fact that Mr. Tilby recognises no interpretative principle such as that which, for Bergson, makes evolution creative. All that is, Mr. Tilby tells us, has emerged in a definite historical sequence, and we have merely to accept the fact and not ask why. The inert we are led to under-

stand preceded the living, and even memory is a purely material fact.

F. C. Donders. *Reden gehalten bei der Enthüllung seines Denkmals in Utrecht, am 22. Juni 1921.* Von Prof. Dr. C. A. Pekelharing, Dr. Sikkel, Dr. A. F. Baron van Lijnden, Dr. J. P. Fockema Andree, aus dem Holländischen übersetzt von Paula Kraiss geb. Engelmann. Pp. 62. (Leipzig: W. Engelmann, 1922.) Fl. 1.

THE unveiling of a statue of F. C. Donders last summer at Utrecht was the occasion for the delivery of several addresses on his life and work. These have been collected, translated into German and issued as a small illustrated booklet. Donders was the founder of modern teaching on the accommodation and refraction of the eye, his great work on which was published in 1864. He was a prolific writer, and a list of his papers (1840-1883) is included: some of his latest contributions deal with colour-blindness.

*The Microscope: A Simple Handbook.* By Conrad Beck. Pp. 144. (London: R. and J. Beck, Ltd., 1921.) 2s. 6d. net.

MR. BECK has in this little book collected and set out in elementary form a considerable amount of information useful to the microscopist. The optics of the instrument are described in a simple manner, and a final chapter deals with pond-life as objects for the microscope. Published by Messrs. R. and J. Beck, the book avowedly deals with the products of that firm, but is none the worse for that so long as the reader is aware that other makers of microscopes exist. We can commend this account of the microscope to the beginner, who will find in it clear directions for use and explanations of many difficulties.

R. T. H.

*Reports of the Progress of Applied Chemistry.* Issued by the Society of Chemical Industry. Vol. 6, 1921. Pp. 638. (London: Society of Chemical Industry, 46-47 Finsbury Square, n.d.) 7s. 6d. to Members; 12s. 6d. to Non-members.

REFERENCE has previously been made in NATURE to the very useful annual reports issued by the Society of Chemical Industry. This year the report is of the same high standard as its predecessors. A particularly noteworthy feature of the separate reviews of the progress made during the year, each written by a specialist, is that the matter is treated critically. The reports are essential to those who wish to follow the progress of chemical industry, and should be in the hands of technical chemists, teachers, and students, all of whom will find matter of interest in them.

*Practical Polishing and Staining.* By A. W. Parkhouse. Pp. viii+120. (London: Benn Bros., Ltd., 1922.) 8s. 6d. net.

MR. PARKHOUSE writes from practical experience, and his book is a very readable and well-informed account of the subject. He very properly lays stress on the importance of close co-operation between the polisher and the cabinet maker, and his book may be recommended to both.

### Letters to the Editor.

[The Editor does not hold himself responsible for opinions expressed by his correspondents. Neither can he undertake to return, or to correspond with the writers of, rejected manuscripts intended for this or any other part of NATURE. No notice is taken of anonymous communications.]

#### The Intensity of X-ray Reflection.

IN a letter on "The Intensity of X-ray Reflection from Powdered Crystals" (NATURE, July 8, p. 38), Prof. A. H. Compton and Mr. N. L. Freeman have described some measurements which they have made on the reflection of X-rays by rock-salt, and have compared their results with figures published by us in the *Philosophical Magazine* for July 1921. Quantitative measurements of the amount of radiation reflected by the crystal are of great interest, since it is probable that an estimate of the way in which the electrons are distributed throughout the atom may be based on them.

In the case of the reflection by the (100) planes of rock-salt, they find a large discrepancy between our figures and theirs. The point at issue may be put as follows. By comparing the incident and reflected monochromatic X-ray beams, and applying formulæ calculated by Darwin and others, it is possible to estimate the amount of X-ray energy scattered by an atom in certain directions in terms of that scattered by a single electron under the same conditions. As the angle through which the rays are scattered is increased, the amplitude of the diffracted wave falls off, owing to interference between the waves scattered by the electrons distributed around the centre of the atom. In the case of the (100) reflection by rock-salt, we found that at the angle at which the reflection takes place the effect of the 28 electrons in a pair of sodium and chlorine atoms is reduced to an effect 20.1 times as great as that of a single electron (p. 7, *Phil. Mag.*, loc. cit.). The ratio 20.1/28 is that indicated by  $\psi$  in this note by Prof. Compton and Mr. Freeman.

We obtained an estimate for  $\psi^2$  by measurements made with a single rock-salt crystal. Prof. Compton and Mr. Freeman determined the quantity by the powder method, measuring the amount of radiation diffracted by a layer of powdered rock-salt spread on a plate, irradiated by an X-ray beam made homogeneous by previous reflection. They obtain a value of  $\psi^2$ , equal to 0.64, correct to 10 per cent., and quote our results as giving  $\psi^2 = 0.43$ , a much lower value.

It may well be that our estimate is too low, for the reasons given by Prof. Compton in his note, with the reasons being fully discussed recently by Darwin (*Phil. Mag.*, May 1922). By using the powder method, the extinction effect, which increases the absorption of the rays passing through at the reflecting angle, is partly or wholly eliminated. We believe, however, that an error has been made in quoting our value for  $\psi^2$  as being 0.43. We obtained

$$\psi = \frac{20.1}{28} = 0.718,$$

$$\psi^2 = 0.515.$$

If this be the case, the discrepancy is not so great as Prof. Compton and Mr. Freeman believe. They used the molybdenum  $K_{\alpha}$  line, of wave-length 0.708 Å.U., whereas we used the rhodium  $K_{\alpha}$  line of wave-length 0.615 Å.U. The value of  $\psi^2$ , however, is independent of the wave-length for a spectrum of given order.

Their estimate for the value of  $\psi^2$  in the case of the

(100) reflection is of the very greatest interest. The measurements made with a single crystal are difficult to interpret for the strong reflections, on account of extinction, though they are probably accurate for the weaker ones. On the other hand, it is just these values for  $\psi^2$  at small angles which are of the greatest importance, as indicating the distribution of electrons in the atom, particularly in its outer confines.

W. L. BRAGG.  
R. W. JAMES.

Manchester University, July 13.

#### Geology and the Primitive State of the Earth.

I HAVE NO wish to depreciate the importance of the work of those geologists who have examined the older known rocks of the earth's crust and decided that all of them have been altered since they first became solid; but I question whether their results afford the evidence concerning the primitive state of the earth that is suggested by Prof. A. P. Coleman and Prof. G. A. J. Cole (NATURE, June 17 and July 8). The deepest boring yet made is one of 2.5 km., and there are few over a kilometre in depth; that is the extent of the crust accessible to geologists. Yet the average thickness of sediments over the continents is probably some kilometres, and in many places it is practically certain that the thickness reaches tens of kilometres. In addition, we have vast thicknesses of intrusive and eruptive rocks. Would it be surprising if all rocks in their primitive state have been denuded away or buried to an inaccessible depth?

Even if it is considered that a piece of primitive crust, still unaltered, has had an appreciable chance of being discovered and examined, I do not see that the results actually found afford any evidence for the cold earth theory as against the hot earth theory. The primitive rocks formed by slow accretion of solid planetesimals would be in a perfectly characteristic and recognisable condition; no such rock has, so far as I have heard, been discovered, and therefore Prof. Coleman's arguments, if they are sound, would be just as injurious to the planetesimal theory as to the hot earth theory.

The temperature of the surface of the earth is at present maintained almost wholly by solar radiation, and not by conduction from the interior. The rate of conduction of heat from the interior is of order  $2 \times 10^{-6}$  cal/cm.<sup>2</sup> sec. The solar constant is about  $3 \times 10^{-2}$  cal/cm.<sup>2</sup> sec. Even if the earth had a solid crust only a mile thick, the surface temperature would still depend wholly on the sun's radiation. Thus it would become cool at the surface at a very early stage in the solidification, and it is not surprising that the oldest rocks should show evidence of water at the surface.

I have published in the *Monthly Notices of the Royal Astronomical Society*, vol. 77, 1916, pp. 84-112, and in the *Proceedings of the Royal Society*, vol. 100, 1921, pp. 122-123, arguments that I believe to be fatal to the form of the planetesimal hypothesis that attributes to solid planetesimals any cosmogonical importance, and postulates an earth that has always been solid. No supporter of this hypothesis has yet published any reply to, or acknowledgment of, these criticisms.

HAROLD JEFFREYS.

St. John's College,  
Cambridge, July 10.

#### $\alpha$ -Particles as Detonators.

THE observation recorded by Mr. Henderson in a letter to NATURE of June 10, under the above heading, appears to involve possibilities of the greatest prac-

tical importance. Mr. Henderson found that under suitable conditions an  $\alpha$ -particle may cause the detonation of nitrogen iodide, about one  $\alpha$ -particle in  $10^7$  or  $10^8$  being effective. He suggests that other unstable substances may be similarly affected. The question naturally arises as to whether any of the explosives commonly used are sufficiently unstable to be detonated in this way. As they are all very much more stable than nitrogen iodide we would expect that the chance of an  $\alpha$ -particle causing detonation would be much smaller, so that an explosion might only occur after a lengthy exposure to a copious source of  $\alpha$ -particles. Still, in view of the almost universal presence of small traces of radioactive matter, it is possible that some unexplained explosions have been brought about in this way. It would appear to be worth while to conduct an investigation into the possible effect of  $\alpha$ -particles on various explosives and detonators. If it is found that there is even the remotest possibility of detonation occurring, precautions should be taken in the manufacture of explosives to reduce the radioactive contamination to the lowest possible value.

HORACE H. POOLE.

Royal Dublin Society, July 11, 1922.

#### Occurrence of a Crystalline Style in the American Slipper Limpet (*Crepidula fornicata*) and its Allies.

DURING recent investigations, carried out with the aid of a Government grant, on the oyster beds in the river Blackwater, freshly caught specimens of the American slipper-limpet (*Crepidula fornicata*) were examined fresh microscopically, and the interesting fact was established that this species possesses a crystalline style. Individuals which have been out of water 24 hours or more still possess remains of the style, which has undergone partial solution. *Crepidula* differs therefore in this respect from the native oyster (*O. edulis*), the style of which is frequently completely dissolved within 3 to 5 hours after individuals are taken out of water, and is completely dissolved in all specimens after about 10 hours out of water.

In the style of *Crepidula* occasional Spirochætes (*Cristispira balbiani*?) were seen, but not identified. By analogy it was suggested that the allies of *Crepidula* should also possess a crystalline style, and an examination of fresh specimens at Plymouth at once proved the surmise correct in the case of the species *Calyptrea chinensis* and *Capulus hungaricus*. It is highly probable, therefore, that a crystalline style is present in the whole of the Calyptræidæ and the Capulidæ; it is also not improbable that a style may be present in all sedentary non-parasitic Streptoneura.

I have long suspected that a crystalline style—particularly in molluscs—is associated with a mode of feeding which consists essentially in the capture of planktonic organisms by mucus controlled by harmonised ciliary mechanisms. The discovery of a crystalline style in *Crepidula* and some of its allies, which all feed in the manner mentioned, lends some support to this idea; but too little is known of the habits of other gastropods which definitely possess a style, to permit of a general correlation of the presence of style with capture of food by means of mucus. Some indications have been obtained by rough hurried experiments that the style substance is a good solvent for mucus; and if this observation can be confirmed it may well be shown that the dissolving of the

mucus enveloping food-masses is one of the most important functions of the crystalline style.

J. H. ORTON.

The Marine Biological Laboratory,  
Plymouth, July 13.

#### Sense of Smell in Birds.

IN the issue of NATURE for June 17 there is a discussion on the inadequacy of present observations on the sense of smell in birds. Perhaps the following notes would be of interest. They are from an account of the habits of the birds of Trinidad which will be published shortly by the Department of Agriculture of that island.

On September 20, 1918, I observed large numbers of the black vulture (*Cathartes fætens*) collected on and round a field which had recently been experimentally manured with liquid slaughter-house refuse and could be smelt a quarter of a mile away, although nothing was visible to the eye. A few red headed vultures (*Cathartes aura*) were also present. In Panama the same birds quickly found the body of an animal that I put close to the trunk of a thick tree, quite invisible from above.

Still more interesting is an observation by Hart (Bull. Dept. Agr. Trinidad II., p. 155), who records that *Cathartes fætens* used to collect in the morning hours on trees near a plant of *Aristolochia gigas* v. *sturtveantii* which was flowering, and which has a particularly strong odour. There can be no doubt that these birds have an efficient sense of smell. At the same time I think that their congregation in numbers is due to watching the movements of their neighbours.

C. B. WILLIAMS.

Ministry of Agriculture, Cairo, Egypt,  
June 29.

#### The Skull of Sir Thomas Browne.

IT may be known to some readers of NATURE that the skull of Sir Thomas Browne has recently been reentered at Norwich, but that previously it came to London, where careful measurements, drawings, and tracings of it were made. It is proposed to publish a full account of the skull in *Biometrika*, but it would add much to the interest of the proposed monograph if it were accompanied by a series of reproductions of the portraits and engravings of one of the most noteworthy of Englishmen who have combined the study of medicine with the pursuit of literature.

The large number of plates required to illustrate adequately the relation of the skull to the portraits renders—under the present conditions of both printing and illustrative work—the appearance of a complete monograph, such as we desire to see issued, very difficult. We propose, therefore, to issue one hundred copies of the monograph at the price of one guinea each, if lovers of Sir Thomas Browne can be found in adequate numbers to subscribe for copies. Will you kindly permit us to appeal through your columns for the names of those who are willing to aid in this scheme for putting on permanent record the physical aspect of the author of the "Religio medici," who, by that and his other works, has won a unique position in the heart as well as in the mind of every cultured Englishman? Willingness to subscribe may be notified to either of the undersigned at the Royal College of Surgeons, Lincoln-Inn Fields, and University College, London, respectively.

ARTHUR KEITH.  
KARL PEARSON.

London, July 12.

## Bloomsbury and the University of London.

By T. LL. HUMBERSTONE.

**B**LOOMSBURY, originally Lomosbury, was in ancient days a retired village, renowned for its wholesome and pleasant air, situated with its manor near the present Bloomsbury Square. The Royal mews, established here, were burnt down in 1537, when the hawks and steeds were removed to Charing Cross. Two great houses were in the neighbourhood—Montagu House, which became the British Museum, and Southampton House, afterwards called Bedford House, near the present Russell Square. To the north,

was preserved the belief that Great Ormonde Street was the hub of the fashionable world.

The British Museum forms the natural centre of the district. Its establishment was due to a man of high scientific attainments, Sir Hans Sloane, a physician, who for a quarter of a century was president of the College of Physicians. He accumulated at his house in Chelsea a vast and varied collection of books and manuscripts, objects of natural history, and works of



(Photos by Central Aerophoto Co.)  
 A=BRITISH MUSEUM. B=FOUNDLING HOSPITAL. C=RUSSELL SQUARE. D=BEDFORD SQUARE. E=WOBURN SQUARE.  
 F=INSTITUTE OF CHEMISTRY. G=ROYAL INSTITUTE OF PUBLIC HEALTH. H=TORRINGTON SQUARE. I=SITE FOR INSTITUTE OF LONDON.  
 J=SITE FOR INSTITUTE OF PUBLIC HEALTH. K=UNIVERSITY OF LONDON UNION. L=CAVENDISH'S HOUSE.

stretching towards Hampstead and Highgate, was open country with irregular patches, frequented by duellists, and the scene of robbery, murder, and every form of depravity.

Russell Square was built at the beginning of the nineteenth century, and became the resort of "gentlemen of the long robe." In those days, or somewhat earlier, Great Ormonde Street was a centre of fashion, but in course of time the district lost caste, and it was accounted a mark of high breeding not to know the locality. Croker inquired in the House of Commons, "Where *is* Russell Square?" It is recorded, however, that the dignity of this once patrician quarter of London

art, which he directed by his will should be offered to the nation on favourable terms. After his death, in 1753, an Act of Parliament was passed approving the acquisition of the collection, together with the Harleian Library of Manuscripts and the Cottonian Library; and to house the collections the Government purchased Montagu House, raising for this purpose, by means of a lottery, the sum of 100,000*l.*, of which 20,000*l.* was used for the purchase of the Sloane Collection. The museum was opened in 1759, and ever since has been available for "studious and curious persons," to quote the official regulations. In its gardens were encamped, in 1780, the troops who quelled the Gordon Riots.

George IV.'s Library was afterwards purchased, the *Quarterly Review* spitefully remarking that women's looks were the only books His Majesty required. The present building was designed by Sir Robert Smirke. It was commenced in 1846 and cost 800,000*l.*, an amount which is worth remembering in view of the fanciful estimates of the cost of housing the University of London on the adjoining site. The dome of the library is said to be the largest in the world, with the exception of the Pantheon at Rome. The north extension is a recent addition of great architectural dignity.

The next-most important building in Bloomsbury is undoubtedly University College in Gower Street, founded in 1826 to afford "literary and scientific education at a moderate expense." Tom Campbell, the poet, and Lord Brougham share the credit for its foundation. Campbell, in his letter to the *Times*, suggested that a number of the "middling gentry" in London would be prepared to pay 50*l.* to furnish the inside of their skulls, that being the amount willingly paid for a full-bottomed periwig for external adornment. The College was nicknamed Brougham's "patent omnibus" as a play on the motto *Patens omnibus Scientia*. From the first, however, the ideals of the College were high and comprehensive. "May God," prayed H.R.H. the Duke of Sussex in laying the foundation stone on April 30, 1827—it should be noted that the centenary of this auspicious event is rapidly approaching—"bless the undertaking which we have so happily commenced, and make it prosper for the honour, happiness, and glory, not only of the metropolis, but of the whole country." This odour of sanctity was short-lived, for the Church party stigmatised the institution as the "Godless College," and established King's College in the Strand as an antidote. Nevertheless, the Duke's prayer has been answered; the bare fact of the inclusion of Lister's name in the list of distinguished *alumni* would be sufficient proof. After the ceremony the company dined together at the Freemasons' Tavern, thus establishing an early tradition of good-fellowship. The beautiful buildings, with the characteristic portico and graceful cupola, were designed by William Wilkins, the architect of the National Gallery.

The College is not included in the photograph, but to the north of the British Museum are to be seen the four plots recently purchased by the Government for the new headquarters of the University of London. The whole of Torrington Square and parts of Russell and Woburn Squares also belong to the University site of 11½ acres, to which it is proposed to move King's College also in the fulness of time. This is not the occasion to attempt even the briefest summary of the controversy which has raged round this question during the past eleven years. One point is, however, pertinent, as it is illustrated by the photograph. It has been charged against the site that its division into four plots is a great disadvantage. Could it not be urged with equal force that this is one of its greatest advantages? The four plots will permit of the construction of a group of well-lighted and ventilated buildings, with numerous entrances and appropriate purposes. The alternative of a mammoth single building would inevitably suffer from defects of lighting and ventilation, and would cause endless annoyance through the waste

of time involved in pacing long corridors. The modern civic university must be, literally and figuratively, on the street rather than in some secluded grove. As will be seen, one of the plots is occupied by some wooden buildings, which have been acquired by the University Union Society from the Young Men's Christian Association as a temporary home. Immediately to the north is the University Institute of Historical Research, established last year for the benefit of students pursuing their investigations at the British Museum, the Public Record Office, and other archives. There they will come "to discuss their problems and results, and to receive that oral guidance for which they are properly debarred in libraries and manuscript departments." The Institute includes departments for English and Colonial history, naval and military history, the history of London, and of various foreign countries, and palæography. The plan is admittedly "opportunist rather than ideal," but the Institute may serve as a model and forerunner of numerous University Institutes for special studies. Between the wooden buildings and Gower Street is the site of the new Institute of Public Health to be established by the Rockefeller Foundation.

Bloomsbury has many interesting associations, as the plaques fixed to its houses testify. These are mostly literary or artistic, but occasionally scientific. At the Bedford Square end of Gower Street is the house where Cavendish, the chemist and philosopher, lived for some years. The house became packed with books and apparatus, and another in Dean Street, Soho, was taken as a library. When Cavendish wanted a book he signed a formal receipt. Enormously wealthy, he made no use of his money. His daily fare consisted of legs of mutton; and it is said that when his servant informed him that the one leg of mutton in the house would not be sufficient for the company, Cavendish instructed him to get another. Such simple direct answers to difficult questions are the acid test of greatness. We read also that Cavendish gave to Humphry Davy some bits of platinum for his experiments, and visited him to see the results of his experiments on the decomposition of the alkalis. He died in 1810.

While the Bloomsbury landlady, to whom respectful tribute has already been paid, remains extant, the district, as a whole, is rapidly changing in character. Russell Square and Bedford Square and the adjoining streets provide accommodation for a large number of learned and other societies of an academic character, and for several teaching institutions connected with the University of London, in addition to those already mentioned. The district is favoured by foreign consulates, the legal, architectural, and other professions, and by business concerns for administrative purposes. It certainly offers many attractions in its "wholesome and pleasant air," its nearness to the great railway termini, its dignity and traditions, its faint historical aroma, its spacious squares and wide streets. As London grows, a process which continues without rest or abatement, the importance of its central areas must be accentuated for all public and private purposes involving the visitation or meeting together of people from the environs of the city. Therefore, whatever its detractors may allege, the future of Bloomsbury is assured.

### The Physiology of Life in the Andes.<sup>1</sup>

By J. BARCROFT, C.B.E., F.R.S.

THE recent expedition to Peru was initiated under the auspices of the Royal Society. So far as the British members were concerned, it was financed in part by a grant made by that body, in part by two substantial private subscriptions from Sir Robert Hadfield, then on the Council of the Royal Society, and Sir Peter Mackie, who has on previous occasions been a staunch supporter of anthropological research undertaken by the Royal Society. In part also its expenses were met by grants from the Moray and Carnegie funds in Edinburgh. These grants paid some of the expenses of the expedition as a whole, together with the personal expenses of three of its members—namely, Dr. J. C. Meakins, professor of therapeutics in Edinburgh; Mr. J. H. Daggart of King's College, Cambridge; and myself. The project was warmly supported by a number of institutions on the American continent, each of which sent a member of the party at its own expense. Harvard Medical School was represented by Dr. Bock, Dr. Forbes, and jointly with Toronto Medical School by Prof. Redfield; the Presbyterian Hospital, New York, by Dr. George Harrop; and the Rockefeller Institute by Dr. Carl Binger. The American and British parties sailed from New York and Liverpool respectively in the middle of November, the American section arriving in Peru a fortnight or more before we did.

I have perhaps given the impression that the party consisted of two sections from different continents, sharply marked off from one another, and neither of which had seen the other before. This impression is erroneous, for the whole idea of the expedition grew from the fertile soil of collaboration in the researches carried out under a single roof. Dr. Redfield and Dr. Bock had been working in Cambridge (England) throughout the previous year, and Dr. Harrop had been there for a short time. There the scheme had been hatched, the methods standardised, and a number of the controls carried out.

Why did we go to Peru, or, more precisely, to Cerro de Pasco? The question may most easily be answered by comparing Peru with some of the other localities to which we might have gone, and to which others have gone before us; for example, Monte Rosa, Pike's Peak in Colorado, the Peak of Teneriffe, and the Himalayas. Without going at length into the merits of each, the advantages of Peru will be sufficiently apparent if I compare it to one of the above, and I will select one of which I have personal experience, namely, the Peak of Teneriffe. Peru and Teneriffe have in common the merit of being close to the sea. In either case the baggage can be put on board at Liverpool or Southampton and taken to your mountain base without further transhipment. Peru, however, possesses the first necessity of laboratory equipment—an abundant supply of water—up to a height of 16,000 ft., *i.e.* 4,000 ft. higher than the Peak. In the latter place the highest altitude at which I know of water is 7,000 ft., while at 11,000 ft.—near the situation of the Alta Vista hut—there is an ice-cave from which water may be obtained by melting the ice.

Again, the conditions of transport are vastly different

in Peru from what they are in Teneriffe. In Teneriffe everything goes up the mountains by mule. The amount of apparatus which can be taken up is therefore small; and if it arrives whole at its destination the worker is fortunate. If it arrives broken, there is little hope of mending it. We were very fortunate, at an early stage of our preparations, in getting in touch with Mr. Oliver Bury, the chairman of the Peruvian Corporation. The Peruvian Corporation owns, among other railways, the trunk line which goes directly inland from Lima, climbs the Andes to a height of almost 16,000 ft., and then drops down to Oroya (12,000 ft.), situated on the pampa between the two parallel ranges of the Cordilleras. From Oroya railways run north to Huancayo, and south to Cerro de Pasco (14,200 ft.), which place was to become our principal seat of operations. To the Peruvian Corporation we owe our laboratory. For the purpose we were assigned a luggage van, 45 ft. in length, together with a goods van which we used as a store; and these they offered to take to any locality on their system at which we desired to work. While the American members of the party awaited our arrival at Lima, they fitted up the luggage van and made a very fine laboratory of it. At one side the door was closed up and windows put in its place, benches and shelves were fitted, electrical wiring was installed, and ultimately we had electric light, power, and heat. What greater contrast in efficiency could exist than between our mobile laboratory at Cerro, jacked up off the bogies to prevent vibration, fitted with X-ray plant and apparatus for the measurements of hydrogen ions, on one hand, and the Alta Vista Hut in Teneriffe, with its paraffin stoves which emitted little but smuts and barely sufficed to melt a few handfuls of ice. Of more account, however, than all these advantages was the fact that, up to an altitude of 16,000 ft. in Peru there is a population most of which is connected with the mining industry. This population may be divided into two categories, namely, the Anglo-Saxon officials and the native labourers. The latter are of Indian descent, and as a race have lived at this altitude for many generations. In Cerro they are designated "Cholo," a name that has no exact anthropological significance, but I shall use it and so avoid an assumption of anthropological knowledge which I do not possess.

To judge from the customs which prevail in the outlying villages, the Cholo is not far removed from a very primitive civilisation. Within a mule-ride of Gollarisquisga there are communities in which private ownership of land does not exist; the land, as in some of the Russian communities which are, or were, on the Canadian prairie, belongs to the village. The produce, if the village is small, is placed in the church; in the larger villages there is a store for this purpose. If the stock of some commodity has run out, some person goes to such a market as Huancayo and buys some more, not for himself, but for the village. I said "buys"; but there are places to which money has scarcely penetrated, and where the exchange of commodities is still a process of barter. The condition of medical science in these villages may be gathered from the fact that such

<sup>1</sup> From a discourse delivered at the Royal Institution on Friday, June 9.



nostrums as horse-dung and well-kept human urine occupy an honourable place in the pharmacopœia, and that a custom appears to linger by which, when the practitioner has done his best—or worst—and failed, the services of another official are called in. He is the "despenador" or "putter out of pain." I need say no more of his or her duties than to give the following quotation from Bensley's "Spanish and English Dictionary": "Despenadora—a woman who is supposed to push her elbow into the stomach or breast of dying persons to relieve them from agony."<sup>1</sup>

It seems clear then that the Cholo, not the Cholo of Cerro de Pasco or Oroya, but of some of the far outlying districts, has been little touched by the Spanish or even the Inca civilisation, and that in him we have a subject for physiological research whose like has varied little for generations. In physique he is short in stature and sallow, or with some blood in his cheeks. That part of his anatomy which was principally of interest to our party was his chest. We made a considerable number of chest measurements. As regards the chest circumference the following statement sums up our findings. We based our measurements on Prof. Dreyer's tables, accepting his estimate of the normal ratio between the trunk length and the chest circumference. We ascertained that the average circumference of the Cholo chests which we measured would normally be 79 cm. It was, in point of fact, 92 cm. As a rough check we measured our own trunk chest ratios and those of the American and British engineers, a community of fine physical development. The circumference of the Anglo-Saxons was little in excess of Dreyer's estimate. The lowest level at which we came across one of these small people with chests which appeared out of proportion to the rest of his stature was at Matucana (8000 ft.), and on inquiry we found that he was a native of Huancayo (12,000 ft.).

To pass to the more strictly physiological aspects of the work of the expedition, one must reflect that the desire to investigate mountain sickness goes back at least to the middle of the last century. It is remarkable, when one comes to think of it, how recently our knowledge of the causation of disease has grown. The lure of mountain sickness to the physiologist lay originally in the fact that it was a disease to which a definite cause could be assigned. You go a certain height up the mountain—any mountain—and when your ascent corresponds to a given fall in the barometer you suffer from mountain sickness; when you descend, the malady leaves you. Mountain sickness, or as it is called in Peru, "seroche," seemed to form a sort of opening into the ætiology of disease.

In recent years the centre of interest has to some extent shifted. The cause of mountain sickness is universally regarded as insufficient oxygen supply to the tissues of the body, though there may still be some doubt as to the directness of the connexion between the deficiency of oxygen pressure in the blood and the activity of the nerve cells responsible for the continence of food in the stomach. Interest latterly has centred rather around the methods which the body has at its disposal for adapting itself to such a condition. But the same thread still runs through the fabric; this

particular instance of adaptation to environment is studied because our knowledge of the conditions with which the body has to deal are so exact and the conditions themselves so easily produced or abolished.

Partly, of course, it has another interest, namely, that imperfect oxygenation of the blood is a factor in a number of pulmonary complaints and an analysis of those complaints demands an investigation of this particular factor. That is the definitely medical aspect, of which I shall say but little. Rather I shall turn my attention to the extent to which adaptation can take place, and the means by which it is brought about.

Some of the Cholos appear at first sight to have acquired an astonishing capacity for physical effort at high altitudes. An example may be cited. Near Cerro de Pasco there is a mine worked in the old Spanish way. The ore is raised from the bowels of the earth on the backs of porters, who carry their loads up a rude staircase. The mine is about 250 feet below the surface, and the staircase about 650 feet in length. It opens under a sort of hut. The first porter whom we saw emerge was a little fellow, who said that he was ten years old. We so far doubted his word as to place his age at thirteen or fourteen years. He had on his back a load of ore which I estimated at 40 lbs.—and that at an altitude at which the barometer stood at only 458 mm., or about 18 inches. Shortly a more mature boy appeared—perhaps seventeen or eighteen years of age—his load was about 100 lbs. To understand these feats, it must be remembered that exercise may be of two kinds, spasmodic or continuous. In the case of continuous exercise, such as that of long-distance running, the subject must maintain an approximate equilibrium between the oxygen which he uses and that which he absorbs. His oxygen account must, so to speak, balance approximately at any given time. In the case of spasmodic exercise it is otherwise. If the subject is prepared for the exercise to cease after a very short time, he may expend oxygen at a greater rate than he takes it in, and thus overdraw his oxygen account. A limit is, however, set to the overdraft, and when that limit is reached he must rest till his oxygen account has righted itself. This formed the subject of a most interesting investigation carried out by Dr. Lupton recently in the laboratory of Prof. A. V. Hill. The porters in the old Spanish mine raise their loads by a series of spasmodic efforts, each of which is followed by a rest of considerable length accompanied by great respiratory distress.

Of the means by which the body acclimatizes itself to oxygen want, real or alleged, we investigated the following:

#### 1. *Secretion of oxygen by the pulmonary epithelium.*

Numerous direct estimations were made of the oxygen pressure in the arterial blood, and in the alveolar air. The two usually came out within two or three millimetres of one another, which is approximately the experimental error of the method. Such a coincidence can only mean that the oxygen passes into the blood by a process of diffusion through the very attenuated partition of epithelium which separates the air from the blood in the lung. Thus the view that the lung could enable the body gradually to overcome the effects of altitude by creating a sort of forced draught

<sup>1</sup> I am indebted for this quotation and much else to Mr. Murdock, manager of the coal mine at Quishuareanca.

and maintaining the oxygen pressure in the blood at its sea-level value is unfounded.

However, the blood as it leaves the lung must contain appreciably less oxygen than its hæmoglobin would normally absorb. It is, to use the American phrase, *unsaturated* to a considerable degree. Such blood, of course, would lack the bright scarlet colour of true arterial blood. The actual colour of the blood as withdrawn from the radial artery entirely bore out this view; as it flowed into the syringe it was of a dull red colour often verging on chocolate, and in the case of the natives was 82.86 per cent. saturated with oxygen, instead of 95.96 per cent. as at the sea level.

Curves giving the relation between the percentage saturation of the blood and the partial pressure of oxygen in lungs at Lima and Cerro de Pasca for different members of the party are shown in Fig. 1, from which

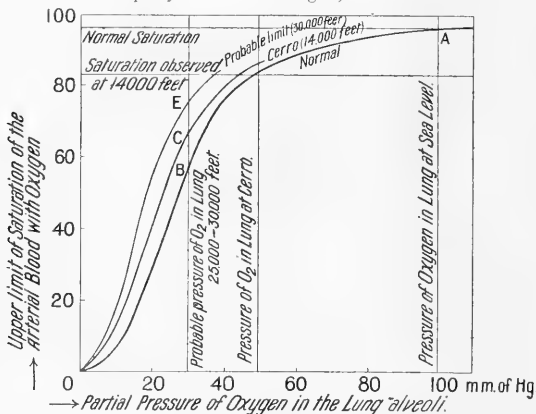

FIG. 1.

it is apparent that at high altitudes the partial pressure required to secure a percentage saturation sufficient for life decreases considerably.

The establishment of the fact that life can be supported with some degree of efficiency with the blood in this condition is of great importance, because in recent years there has been a tendency to assume that a small degree of unsaturation of the arterial blood must of necessity produce very grave results. Fig. 1 shows that there is some adjustment of the blood to the new conditions. At Cerro the unsaturation of the blood was written on the faces of the inhabitants. Any one who had any colour in his face was appreciably cyanosed.

2. *Increased pulmonary ventilation* has been shown by all recent observers to be of great importance as a factor in adaptation to high altitudes. In our case, had our respiration been the same in rate and depth at Cerro as it was at Lima we would have had about 40 pressure mm. of carbonic acid and 35 mm. pressure of oxygen in the air of our lungs. In fact, owing to increased respiratory effort, we reduced the carbonic acid to about 25 mm. and raised the oxygen to about 52 mm. The importance of these facts is enhanced by the certainty that it is the partial pressure of

oxygen in the alveolar air which regulates the degree of saturation of the blood.

While the increased ventilation of the lung had been demonstrated by previous observers, the mechanism which was responsible for it had been much in dispute. This we investigated. The mechanism of hypernoea at rest seems to be that first suggested by Haldane, namely, that the want of oxygen heightens the activity respiratory of the respiratory centre, resulting in a mild degree of forced respiration—so mild as not to be apparent to the subject, yet sufficient to reduce the carbon dioxide content of his blood. Incidentally this process acting alone would make the blood more alkaline. The measurements of hydrogen ion concentration in the blood of persons at rest bore out this view; either the blood was more alkaline than at sea level, or it was of approximately the same reaction.

The effect of exercise on the blood has been more fully investigated, though for the most part by indirect methods. Our results support those already obtained, namely, that a given increment in the hydrogen ion concentration of the blood is produced by less exercise at high altitudes than at the sea level. Thus the dyspnoea of exercise is the cumulative effect of two factors—an increased response of the respiratory centre to a given stimulus, and an increase in the stimulus evoking the response.

3. I have already alluded to the size of the Cholos chest. With it appears to be associated an interesting modification of its configuration. Fig. 2 shows two X-ray photos of the left sides of two chests photographed from behind. Both pictures were made at Cerro de Pasco. That on the right is my own, and is fairly typical of our party; that on the left is a typical Cholo chest. There is a marked difference in the angle at which

the ribs are carried; my own slope down from the vertebral column at a quite considerable angle, while those of the native are much more horizontal. It seems highly probable that this horizontal carriage of the ribs indicates a compensatory effort designed to increase the facility with which the blood obtains oxygen, for it is acquired at sea level by persons suffering from emphysema and other complaints in which there is shortness of breath. Several of the mining engineers, of whose chests we took radiograms, showed a similar tendency. At this point another peculiar physical conformation may be mentioned, namely, clubbing of the fingers, which, when found at sea level, is frequently associated with some trouble which prevents sufficient oxygen from reaching the extremities. Though they are not the rule, clubbed fingers are by no means unusual at Cerro de Pasco in persons without any circulatory or respiratory lesion.

4. An increase in the number of red blood corpuscles in each cubic mm. of blood has long been known to occur at high altitudes. Systematic researches carried out principally under the direction of Dr. Haldane have shown that the increase in the number of red blood corpuscles is associated with an increase in the quantity of hæmoglobin present. These two observa-

tions we have verified, and to them have added a third, namely, that the chemical conditions under which the hæmoglobin is held in the red blood corpuscle confer on it the peculiarly useful property of acquiring more oxygen when exposed to rare atmospheres than is the case with normal blood.

5. We sought in vain for any such form of acclimatization as might be afforded by the driving of an increased volume of blood round the body in unit time. A rather natural supposition would be that, if the hæmoglobin of each cubic centimetre of blood were deficient in oxygen, the tissues might be fed with sufficient oxygen by the simple process of giving them more blood; but this is not so. It is true the heart quickened with exercise, but the quickening seems to have been rather a signal of distress than a compensatory mechanism.

Three principal forms of compensation have been described: they are increased total ventilation, increased expansion of the chest, increased hæmoglobin, and increased affinity of the blood for oxygen; their relative importance is a matter for future research. Jointly or severally they may mitigate the effects of oxygen want, but they cannot entirely abolish them; at some altitude the human frame must always succumb. We were naturally somewhat interested in the question of whether we could foretell which of our own party would succumb most quickly, and various members of the party worked out systems of prophecy which differed not only in character but in the prophetic order in which the various individuals would prove susceptible to altitude. One of these proved quite successful. It was based on the determination of Bohr's diffusion constant (the ratio of the quantity of oxygen absorbed per minute to the average difference of pressure between the oxygen in the alveolar spaces and alveolar capillaries) for the lung, and was suggested by Prof. Krogh. The members of the expedition could be divided into two distinct groups—those who had a constant for oxygen of more than 40 and those who had a constant less than that figure. One group with the higher diffusion constant suffered from obvious symptoms of mountain sickness, while the other did not. It is true that of the four who suffered the salient feature was different in each case: in one it was faintness, in another vomiting, in a third high temperature and intense headache, and in the fourth deafness and indistinct vision. Only further research can show whether the coincidence was fortuitous, or whether any causal relation exists between the diffusion constant and the tendency to "seroche." The hint, however, seemed to be worth taking, and in consequence an arrangement has been come to by which persons intending to go to the mining districts in the Andes are being tested in the Rockefeller Institute in New York.

I must also make some allusion to the goodwill which was extended to us by every one with whom we came in contact in Peru, from the President down to the humblest employee of the Cerro de Pasco Copper Corporation. Of the manager and the officials of this company we can only say that their kindness in placing themselves and their resources at our disposal was one of the most potent factors in enabling us to achieve such scientific results as we obtained. No less can be said of the officials of the Pacific Steam Navigation Company.

The problem of Everest from the point of view of physiology, upon which our work in the Andes throws some light, may be stated thus:

Every cubic centimetre of arterial blood which leaves the lung must contain a certain quantity of oxygen,

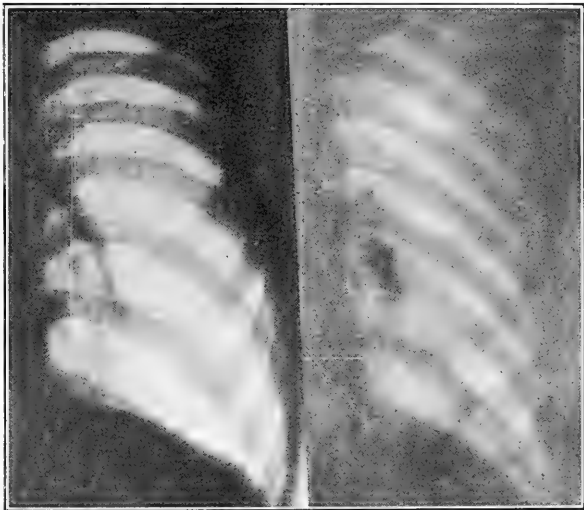

FIG. 2.

expressed as a percentage of the maximum which the blood can hold, if life is to be maintained at a level consistent with any degree of efficiency. It is not known what this quantity of oxygen may be. The following considerations, however, give some clue to it:

(a) Let the maximum quantity of oxygen (shown on the ordinate of the graph in Fig. 1) which the blood can hold be called 100.

(b) There is a certain relation in the blood for normal persons between the amount of oxygen it can hold and the pressure of oxygen to which it is exposed; that relation is shown in the graph labelled "normal." (The partial pressure of oxygen forms the abscissa.) At the sea level the oxygen pressure in the lung is about 100 mm. and the quantity of oxygen in the blood 96 per cent. of the possible load. (See the point A on the graph.)

(c) Until recently it was supposed that the curve did not alter, and therefore the graph labelled "normal" stood for all altitudes.

(d) Also the most competent authorities regarded an oxygen load of about 90 per cent. of the possible maximum as being required for the conduct of life—apart from short exposures.

(e) The probable partial pressure of oxygen in the lungs at 25,000-30,000 feet is calculated by a process of extrapolation to be about 30 mm. Combining *c*, *d*, and *e* above, the quantity of oxygen in the arterial blood on Everest would be 58 per cent. of the maximum—far below that necessary.

(f) The recent expedition to Cerro de Pasco has brought out two new points:

(1) That natives lead a reasonably normal existence with blood charged only up to 82 per cent. of the

possible, and Europeans with 85 per cent. of the possible, load of oxygen.

(2) That the graph changes in position, and for natives and Anglo-Saxons approximates to that labelled Cerro (14,000).

(g) On this graph a partial pressure of 70 mm. of oxygen in the lung might saturate the blood up to 67 per cent. (c).

(h) It is scarcely likely that the curve moves further than that marked "Probable limit (30,000 ft.)." On that curve, however, the blood would be charged up to 76 per cent.—a figure within a reasonable distance of what has actually been observed in the Andes.

## Obituary.

### H.S.H. PRINCE ALBERT OF MONACO.

NOT infrequently in the past have princes and nobles been munificent patrons of science and played a useful part in promoting the advancement of knowledge—would that we had more such at the present day—but it must be rare indeed for a reigning prince to attain recognition and distinction as a practical, working, man of science. The late Prince of Monaco, whose death took place recently, was both. He has given to France and the world of science at least three research institutions of first-rate importance, and throughout many years of his life, during the last half-century (since, in January 1873, on one of his early expeditions he met the *Challenger* at Lisbon), he has himself planned and carried out many notable investigations in both physical and biological oceanography.

His Serene Highness Prince Albert Honoré Charles, a descendant of the ancient House of Grimaldi, was born in 1848, and succeeded his father, Prince Charles III., as ruler of the principality of Monaco in 1889. In his early youth Prince Albert served as lieutenant in the Spanish Navy, and since then has shown a life-long devotion to the sea and a rare enthusiasm for its scientific exploration. Probably the most characteristic representation of the Prince is the statue in the entrance hall of the Museum of Oceanography at Monaco showing him in plain sailor's uniform standing at the rail on the bridge of his yacht. He must have spent a large portion of his life, and much of the ample funds at his disposal, in the many expeditions which he conducted in the successively larger and more perfectly equipped yachts *Hirondelle* (a 200-ton schooner) and the first and second *Princesse Alice*—the last a magnificent ocean-going steamer of 1420 tons, built by Lairds' on the Mersey in 1898, and fitted with all necessary machinery and apparatus for every form of modern oceanographic research, and for the capture of whales. By means of these vessels the "Gulf Stream" in its various parts, and its effect on the coast of France, the Azores, the seas around Spitsbergen, the Mediterranean, and much of the Atlantic from the equator to within the Arctic Circle, were systematically investigated in both their physical and their biological characters. Among his companions and assistants on these expeditions have

been Baron Jules de Guerne, Dr. Jules Richard, and occasionally our own countrymen Mr. J. Y. Buchanan and Dr. W. S. Bruce; and the results of more than thirty annual cruises have been made known to science first by the Prince's preliminary reports in the *Comptes rendus*, and later, in full detail, in those beautifully illustrated, sumptuous memoirs in the series entitled "Résultats des Campagnes Scientifiques accomplies sur son Yacht par Albert I<sup>er</sup> Prince Souverain de Monaco," dating from 1889, and the later series of the *Bulletin* and the "Annales de l'Institut Océanographique."

It is chiefly in connexion with the devising of apparatus for deep-sea research, and with the introduction of new methods of investigation, that the Prince's personal influence was felt on his expeditions. Among other new appliances which have yielded notable results may be mentioned his huge baited traps (the "Nasse"), his various types of trawls and nets for use in different zones of water, and his use of submarine electric lights to attract free-swimming animals with power of vision, such as fishes and Crustacea. There can be no doubt that his practical knowledge as an experienced sailor and as a mechanical engineer has added greatly to the efficiency and success of all his work on the yachts. His chief assistant, Dr. Jules Richard, who has charge of the museum and laboratories at Monaco, gave full descriptions and useful illustrations of many of these appliances for oceanographical investigation in a special volume of the *Bulletin* series that was published about 1900.

All the Prince's successive voyages have been very fruitful of scientific results, and biology owes its knowledge of many deep-sea, Atlantic animals to the special memoirs issued from the Monaco Press; but none of these have been more remarkable, novel, and almost sensational, than the results of the Prince's whale-fishing expeditions, when he obtained the more or less perfect remains of various new, and in some cases gigantic, cuttlefishes (such as *Lepidoteuthis* and *Cuciotheuthis*) from the stomachs of captured sperm whales. Some account of these discoveries and exploits, and of Homeric combats when, for example, three huge killer-whales attacked one of the boats and tried to crush it between their bodies, and again when a large Cachalot died under the keel of the yacht which

it had charged as an enemy, are given in one of the recently published volumes of "Accounts Rendered" by Mr. J. Y. Buchanan, who was a companion of the Prince on several of his expeditions.

There is another oceanographic investigation which will always be connected with the Prince of Monaco's name, and that is his distribution, commenced so far back as 1885, of floating or drift bottles over wide areas of the Atlantic, starting from the Azores as a centre, in order to determine the set of the currents. The knowledge acquired from such experiments extending over many years enabled the Prince to write what is probably the latest of his own personal contributions to science, a paper and map communicated to the French Academy, in 1919, on the future of the floating mines which, having gone adrift as the result of operations in the recent war, may be a danger to navigation in certain parts of the Atlantic for some years to come. He showed how mines from the European coasts will gradually be drawn into the various currents associated with the "Gulf Stream," and how some will, in all probability, continue to circulate in the great whirlpool of the Sargasso Sea, while others will eventually find their way to the Norwegian fjords and the Arctic Ocean and be destroyed ultimately in their encounter with the ice.

The inauguration of the Musée Océanographique, towards the end of March 1910, brought together at Monaco such an international gathering of men of science interested in the exploration of the sea as had never been seen before. Official representatives of many countries, delegates from the great Academies of the world, and others invited personally by the Prince, were united in celebrating the progress of oceanography and in launching an institution unique in character and of first-rate importance for science. This great museum with its laboratories and other workrooms rises sheer from the Mediterranean on the southern side of the rock of Monaco, the lower three stories facing towards the sea being below the level of the old town and palace, and the main entrance to the museum, from the streets, being half-way up the building. From the seaward side the appearance is especially striking, the masonry appearing to be almost a part of the rock and to grow up in a series of arches from the ledges of the cliff itself. This, the first Museum of Oceanography, demonstrates the methods of investigation and the results obtained. It contains the extensive collections made on the Prince's expeditions, and also shows the various types of dredges, trawls, tow-nets, deep-sea thermometers and water-bottles, current-meters, and other apparatus used by the different nations in their explorations of the ocean.

The museum at Monaco is, however, only one part of the foundation which the Prince has provided for the study of the sea. With the object of arousing interest in scientific marine studies in France, he instituted a series of lectures at the Sorbonne in 1903, and in 1906 he gave permanence to these by means of an endowment, and presented to the French nation a building specially devoted to university instruction in oceanography. In connexion with this "Institut Océanographique" at Paris three professorships have been established—one of physical oceanography, one

of biological oceanography, and the third of the physiology of marine life. As was said of him at one of the inaugurations, "By his researches the Prince of Monaco has won for himself a distinguished place in the ranks of men of science, and by enshrining the results in the monumental buildings at Monaco and Paris he has invested his labours with permanent value for all time."

The third great scientific benefaction of the Prince is the Institut de Paléontologie Humaine at Paris, where again, as at Monaco, there is a museum and a laboratory with professors devoted entirely to the investigation and demonstration of one special subject—the early history of man. The Prince's personal interest in prehistoric archaeology has been shown for many years by the explorations he has conducted or promoted at the Grimaldi caves near Monaco and at other caverns and important sites in France and Spain, with Prof. Boule, the Abbé Breuil, and others—and the results, as in the case of the oceanographic investigations, have been published at his expense in princely style. It has been reported in the daily press, since his death, that he has bequeathed a million francs, as further endowment, to each of these three research institutions. He has certainly put to a noble purpose for the advancement of science the ample funds which have come to him under the conditions of the concession granted many years ago to the proprietors of the Casino at Monte Carlo. It is well known that the Prince has expressed publicly his strong disapproval of the pigeon-shooting competitions at Monte Carlo; but considers that as he is not an autocrat, under the terms of the concession, he has no power to interfere with vested interests at the Casino except by the support his name and influence can give to public opinion.

None of those who were present at Monaco as the Prince's guests, during the four days of conferences and celebrations at the inauguration of the Musée Océanographique, will be likely to forget his gracious hospitality, his gravely courteous manner, his evident interest in all the scientific questions raised, and his keen desire to secure co-operation between the different nations in the further exploration of the oceans. In recent years, since the war, he has played a prominent and most helpful part in such international co-operation. He was appointed president of the "Commission internationale pour l'Exploration scientifique de la Mer Méditerranée" at the meeting in Madrid in 1919, and at the recent international conference in Rome he was chosen as president of both the physical and biological sections of oceanography. In all such meetings and in the subsequent work he was no mere figurehead, but took a prominent part in the proceedings. His death, in Paris, on June 26, will leave a great gap in many important organisations, and be felt as a real loss by all interested in the promotion of the science of the sea. He was a natural centre in organisation and a leader in work. In his independent position he stood apart from all international rivalries and showed only a single-minded devotion to the pursuit of truth. As he once said of himself, modestly and truthfully, in an address on his work at sea, in July 1891, to the Royal Society of Edinburgh, "I undertook the mission that lay before me because I was at once

a sailor and devoted to science." And that seems to express his attitude throughout all his work.

W. A. HERDMAN.

THE death is announced in the *Chemiker Zeitung* of June 24 of Prof. W. Hallwachs, of the Technische Hochschule, Dresden, on June 20. Prof. Hallwachs, who was sixty-three years of age, was known for his researches on electricity, particularly on the photo-

electric effect. The same journal also records the death of Prof. Otto Lehmann, on June 20, at the age of sixty-seven. Prof. Lehmann, who has occupied the chair of physics at the Technische Hochschule at Karlsruhe since 1889, was best known for his work on liquid crystals. His first paper on this subject was published in 1890, and his further researches were embodied in two monographs published later. In addition, he carried out work of importance in connexion with discharge and cathode-ray phenomena.

### Current Topics and Events.

COL. E. M. JACK has been appointed Director-General of the Ordnance Survey in succession to Sir Charles Close, who is retiring in August.

THE *Chemiker Zeitung* announces that Prof. H. Kamerlingh Onnes, director of the Physical Institute of the University of Leyden; Dr. P. Zeeman, professor of physics at the University of Amsterdam; and Dr. N. Bohr, professor of theoretical physics at the University of Copenhagen, have been elected corresponding members in the Physical-Mathematical Class of the Prussian Academy of Sciences, Berlin.

THE Charles P. Daly medal of the American Geographical Society has been presented on behalf of the society by the American Ambassador to Sir Francis Younghusband. The medal, which was instituted under the will of the late Charles P. Daly, sometime president of the American Geographical Society, is awarded for valuable or distinguished geographical services or labours, and that presented to Sir Francis Younghusband bears the inscription, "For explorations in Northern India and Tibet and for geographical publications on Asiatic and African borders of the Empire."

SOME appointments have recently been made on the scientific staff of the Field Museum of Natural History, Chicago. Mr. R. Linton has been attached to the department of anthropology as assistant curator of North American ethnology. Mr. Linton has carried out extensive investigations, principally archaeological, in the eastern, central, and south-western United States, as well as in Central America and Polynesia. Recently he has returned from an expedition to the Marquesas Islands for ethnological and archaeological researches, undertaken under the auspices of the Bishop Museum of Honolulu, Hawaii. A new division of taxonomy has been created in the department of botany, and Mr. J. F. Macbride, now in Peru at the head of a botanical expedition for the Field Museum, has been designated as assistant curator. In the department of zoology, Dr. C. E. Hellmayr, well known for his extensive work on Neotropical birds, has been appointed associate curator of birds. Dr. Hellmayr was formerly connected with the Rothschild Museum at Tring, and more recently has been with the Museum of the University of Munich. Mr. Heller, a former associate of Theodore Roosevelt, and Mr. J. T. Zimmer have been appointed assistant curator of mammals and assistant curator of birds respectively;

they are at present engaged in field work in Central Peru. Mr. Karl P. Schmidt, formerly with the American Museum of Natural History, New York, has been appointed as assistant curator of reptiles and batrachians.

JUNIOR Beit Memorial Fellowships for medical research of the annual value of 350*l.*, and tenable for three years, have been awarded by the trustees to the following, the subject and place of research being given after each: Mr. E. B. Verney: The physiology and pathology of urinary secretion, at the Institute of Physiology, University College, London; Prof. F. Cook: A study of the neuromuscular apparatus of the uterus, at Guy's Hospital; Dr. J. L. Rosedale: The chemistry of normal and pathological tissue with special reference to the protein and nuclein constituents, at St. Thomas's Hospital Medical School, London; Mr. R. Hilton: The study of the blood gases in various stages of pulmonary collapse produced by artificial pneumothorax; the condition of the circulation in the collapsed lung, at the Lennec Hospital, Paris, and at St. Bartholomew's Hospital; Mr. A. St. G. J. M'C. Huggett: The investigation of the function of the placenta in relation to the passage of gases and other substances from the mother to the foetus and the cause of foetal apnoea, at the Sherrington School of Physiology, St. Thomas's Hospital, and at the Brown Animal Institution at Vauxhall; and Mr. V. D. Allison: The investigation of the nature and properties of a hitherto undescribed substance which has a strong bacterioidal, bacteriolytic and bacteri-inhibitory action—named lysozyme, at the Institute of Pathology and Research, St. Mary's Hospital. Fourth year Fellowships of the annual value of 400*l.* have been awarded to Dr. D. Keilin: The life-histories of protozoa pathogenic to insects; the life-history, anatomy and physiology of insects, at the Molteno Institute for Research in Parasitology, Cambridge; and Mr. I. de B. Daly: Auriculo-ventricular block, at the Institute of Physiology, University College, London. The trustees of the Beit Scientific Research Fellowships have re-elected Mr. H. L. Riley and Mr. W. A. P. Challenor to fellowships for the year commencing September 1922, and elected Mr. H. W. Buxton to a fellowship for the same period. All the fellows are required to carry out their research at the Imperial College of Science and Technology. Mr. Riley will continue his research on "The

Atomic Weight of Silver, and the Dielectric Constants of Dry Gases" in the chemistry department, and Mr. Challener will continue his work on "Ring Formation in the Aromatic and Aliphatic Series of Organic Chemistry" in the chemistry department, both under the direction of Prof. H. B. Baker. Mr. Buxton will carry out investigations on "Nitrogenous Metabolism in Plants" in the biochemistry department under the supervision of Prof. J. B. Farmer.

THE final attempt, at least for this year, to reach the summit of Mount Everest was made on June 7. The party, according to General Bruce's despatch to the *Times*, consisted of Messrs. Mallory, Somervell, Finch, Wakefield and Crawford, with native coolies. From the outset bad weather was experienced. Captain Finch, feeling the result of his great exertions during the previous climb, had to give up and return. On the North Col the rest of the party were caught in an avalanche; Messrs. Mallory, Somervell and Crawford and one porter were able to extricate themselves unhurt, but the second party consisting of porters were overwhelmed. Three of them were rescued, but seven lost their lives. The attempt to gain the summit was then abandoned. General Bruce writes in terms of great praise of the loyalty and devotion of the native porters, whose loss the expedition felt keenly. Most of the Europeans with the expedition appear to be suffering from exposure at high altitudes; there are several cases of frostbite. It is not yet decided if a new attempt on Mount Everest is to be made next season. Several members of the expedition, including Colonel Strutt, Dr. Longstaff and Captain Finch, have already reached England.

FOR some time past the practicability of measuring the depth of the ocean by means of sound waves reflected from the bottom has been discussed. A short explosive signal is made at the ship's hull and the time of this, and the echo from the bottom, are recorded. Apparently corrections are made for temperature effects on the velocity of transmission of the signal. Obviously the measurements can be repeated very quickly, or they may even be carried out automatically. It was announced in New York, on July 6, that extended trials had been made by Dr. Hayes, on board one of the U.S.A. destroyers, with much success. The outline of the sea bottom on a traverse between Rhode Island and Gibraltar is said to have been charted and minute records between Josephine and Tysburg Banks have been obtained. The bottom here is an extensive plain, bordered by mountains and tablelands rising to a height of 4000 feet above the plain, and containing several unrecorded deeps. Doubtless the apparent uniformity of level over vast areas of ocean bottom is to be explained partly by the paucity of deep soundings: this applies particularly to much of the Pacific Ocean. Should the new method prove trustworthy on critical investigation it will be possible to study the minor differences of depth with ease.

A MEMORANDUM regarding the probable amount of monsoon rainfall in 1922 was submitted to the

Government of India in the early part of June by Dr. G. T. Walker, Director-General of Observatories. As frequently happens there are said to have been temporary advances of the monsoon in May, and in early June the rains began much earlier than usual in upper India, but the advance did not persist. The monsoon rainfall is affected by previous conditions over various parts of the earth, and a summary is given of the recent data which appear to be of importance. Among the factors stated as available are: a slight excess of snow in the mountain region of north-west India, a deficiency of rainfall over Java during the period of October to February, an excess of rain in Ceylon during May, and an excess of pressure at Mauritius in the same month. The data of Java, the Azores, and South America are decidedly favourable, of Iceland and the Cape scarcely appreciable, and of the east African coast decidedly unfavourable. The resulting indication shows that the Peninsula rainfall will be in excess, and for north-west India the rain is likely to be slightly deficient but not far from the normal. The establishment of the Arabian Sea monsoon will probably be delayed. For Upper Burma, north-east India, Mysore, and Malabar the indications are said to be conflicting and a useful forecast cannot be made.

THE Empire Forestry Association, which held its inaugural meeting in November last, was founded with the object of federating all the various societies interested in forestry throughout the Dominions overseas and India, as well as in the home countries. One of the functions of the Association is to disseminate information by means of a journal, *Empire Forestry*, the first number of which appeared in March. This contains about a dozen articles, the most important being a statement by Mr. R. L. Robinson, Forestry Commissioner, concerning forestry practice and available timber supplies throughout the Empire, based on the latest official information and statistics. Canada heads the list, as regards forest area, with 932,420 square miles of forest lands, of which, however, only 390,630 square miles are considered to be merchantable, the remainder being unprofitable or inaccessible. British India is second, with 120,310 square miles of merchantable forests; Nigeria is next, with 50,400 square miles; while Australia has 37,840 square miles. It is fortunate that 75 per cent. of the forest area of the Empire still belongs to the State. There is time yet to preserve the forests from ruthless destruction, by wise legislation aiming at effective regulations as regards felling, natural regeneration, and protection from fire. A useful feature in this number of *Empire Forestry* is a list of books, reports, and other publications on forestry and timbers, issued in 1920 and 1921.

REPORTS on lac, turpentine, and rosin have been issued by the Imperial Institute (London: J. Murray; 5s. net). Shellac is a characteristic Indian product, and indeed 94 per cent. of the world's supply comes from India and Burma. It is a resinous exudation produced by the lac insect, *Coccus lacca*, on various trees. In spite of the practical monopoly enjoyed,

the state of the industry in India is not satisfactory, and recommendations for improvement in the manufacture are given. The other reports deal with Indian turpentine and rosin. These have been produced on a small scale for some time past in the United Provinces and the Punjab, only one species of pine, *Pinus longifolia*, being tapped commercially. The turpentine of this tree is unfortunately inferior to that produced in the American and French forests. It appears that a much better turpentine could be obtained from *Pinus excelsa*, another species widely spread in the Himalayas, but the yield is small. *Pinus khasya* might also be tapped in Assam and Burma. The industry is at present merely in the experimental stage; but it is predicted that, with energetic business methods, the total annual yield, which is now trifling, might be increased in ten years to 120,000 cwts. of turpentine and 430,000 cwts. of rosin.

A CASE in which two cuckoos were apparently reared together in the same nest by a cock blackbird is recorded by Miss E. R. Saunders, Newnham College, Cambridge. A blackbird's nest containing four eggs on which the cock bird was sitting was found and observed. The fact that a dead hen blackbird was found close by afterwards may account for the continued presence of the cock bird on the nest. When the eggs hatched, two of the nestlings were black-

birds, the bodies of which were found on the ground, while in the nest was a young cuckoo. Another young cuckoo was perched on a stake within a hand's breadth of the nest. Cuckoos frequent a belt of trees nearby, and it seems in this case that two eggs were deposited in the one nest.

IN regard to the correspondence in NATURE of March 9 and June 3, under the title "A Rainbow Peculiarity," on the enhanced brightness of the sky within the primary bow, Mr. L. C. W. Bonacina writes to point out that the fact is splendidly illustrated, and duly commented upon, by Mr. G. A. Clarke in his book on "Clouds" published in 1920 (Plate 35*b*).

A NEW classified list of second-hand scientific instruments (No. 75) has been issued by Mr. C. Baker, 244 High Holborn, W.C.1. As is customary in these well-known catalogues, the instruments are arranged in groups and there are long sections dealing with microscopes, many by first-class makers, and telescopes and accessories. Among the electrical apparatus we notice a Marconi receiving instrument, and there is also a quantity of apparatus suitable for other departments of physics as well as surveying and drawing instruments. Most of the apparatus can be inspected at Mr. Baker's premises. A novel feature is the offer for hire, at very moderate charges, of field- and opera-glasses of various types.

### Our Astronomical Column.

SKJELLERUP'S COMET.—The identity of this comet with 1902 II. (Grigg) is now very highly probable. Mr. G. Merton finds, with the aid of recent Greenwich photographs, that the period of Skjellerup is close to 5.13 years, the other elements being nearly the same as those recently given in this column. Further, the following new orbit has been deduced for 1902 II., which represents the observed places within a few minutes of arc, an amount well within their probable error:

$T = 1902, \text{ July } 2.52 \text{ G.M.T.}$

$\omega = 346^{\circ} 41'$   
 $\Omega = 222^{\circ} 40' \left. \begin{array}{l} 1902.0 \\ 1902.0 \end{array} \right\}$

$i = 9^{\circ} 4'$

$\phi = 48^{\circ} 12'$

$\log a = 0.4662$

Period = 5.004 years.

The period was assumed, since the observations are not nearly precise enough to determine it. The other elements are fairly near those of Skjellerup. The differences are explicable by the fact that there was a very near approach to Jupiter at the beginning of 1905. By the above elements the comet was then in Longitude  $29\frac{1}{2}^{\circ}$ , N. Lat.  $2^{\circ}$ ,  $\log r$  0.7081; Jupiter was in Longitude  $32^{\circ}$ , S. Lat.  $1^{\circ}$ ,  $\log r$  0.6950.

THE PARIS ASTROGRAPHIC CATALOGUE.—M. Jules Baillaud notes in *Comptes rendus* for July 3 that this Catalogue, which extends from North Declination  $18^{\circ}$  to  $24^{\circ}$ , is approaching completion, and it is already possible to give data about the number of stars per plate in the different parts of the zone. He does this in two ways: (1) the uncorrected numbers, (2) the numbers after allowance has been made for variations due to imperfectly clear sky, less sensitive plates, etc. These have been estimated by comparing the overlapping portions of adjacent plates. Both sets of numbers are shown graphically. There are two steep

peaks in the curve at  $6^{\text{h}}$  and  $21^{\text{h}}$  R.A., where the zone intersects the galaxy. The curve indicates 1100 stars per region of  $6^{\circ} \times 6^{\circ}.6$  at  $6^{\text{h}}$  R.A., and 1200 stars at  $21^{\text{h}}$  R.A.

The minima are at  $3^{\text{h}}$  and  $14^{\text{h}}$  R.A., where the star numbers are 150 and 70 respectively per  $6^{\circ} \times 6^{\circ}.6$ . There is thus a 14-fold range in star-density. It will be noted that the minima do not fall symmetrically between the maxima.

OBSERVATIONS OF MARS AT SÉTIF, ALGERIA.—M. R. Jarry-Desloges has sent a report to the Paris Academy of Sciences of observations which he and M. G. Fournier have made this year (*Comptes rendus*, July 3). They have used two refractors, apertures 37 cm. and 26 cm.; it is noted that the smaller has practically no secondary spectrum, although there are only two lenses in the objective. While this is advantageous in most cases, M. Fournier finds that for the purpose of detecting slight colour-differences on the planets the former is preferable.

Some of the dusky regions in the southern hemisphere of Mars were seen to be covered with a misty veil, and M. Desloges notes that this was also seen in 1909 when the season on Mars was the same. He also directs attention to the difficulty of tracing the southern boundaries of these dusky regions: a similar difficulty was experienced in 1907, but in intermediate years these boundaries have been well defined. The misty veil is stated to be lifting, so that by June the boundaries could be traced. As a change that is probably not seasonal he adduces the present great development of the system Lacus Moeris, Nepenthes, Thoth, to the left of Syrtis Major. These features were not seen in 1907.

Lacus Phœnicis is large at present, and Lacus Solis is girdled by a system of dark streaks. Fons Juventæ has also been seen.



## Research Items.

**FOLKLORE AMONG THE ALGERIAN TRIBES.**—In the June issue of *Folk-lore* (vol. xxxiii. No. 2) Mr. M. W. Hilton-Simpson publishes the result of a series of excursions among the hill and desert tribes of Algeria. In this hitherto practically unknown field he has found many curious usages. Among others, at a marriage firearms are discharged to scare the Jinn who are on the watch to possess the bride. On her arrival at her husband's house she is lifted into the house by a man, and as she reaches the door a female member of her family presents her with an egg, which she breaks on the lintel as she passes under it. This last usage is sometimes modified by the bride smearing the door-lintel with butter, the series of charms being probably fertility magic.

**RELIGIOUS CEREMONIAL OF THE PARSIS.**—An interesting collection of articles used in religious ceremonies by the Parsis of Bombay and preserved in the United States Museum is described by Mr. I. M. Casanowicz, the assistant curator, in Proceedings of the United States National Museum (vol. lxi. Art. 2), with a useful account of the origin and ritual of these people. The finest object is a brass nickel-plated fire-iron, with a ladle and tongs, used in making the sacred fire, and a similar tray on which offerings of fruit, flowers, milk, water, wine, or sherbet are made in remembrance of the souls of the departed, or with the object of invoking the help of protecting spirits.

**FAR EASTERN ARCHAEOLOGY.**—The July issue of the *Antiquaries' Journal* (vol. ii. No. 3) is devoted to the presidential address by Sir Hercules Read, who took as his subject the work of Sir Aurel Stein carried on for twenty years in exploring Eastern Turkestan. "The masterpieces of the earlier dynasties of China stand unchallenged in our museums and in private possession. Their value and interest are enhanced beyond words when we have in addition such a collection as that brought home by Sir Aurel Stein. By singular good fortune he has retrieved just the very objects that the earth can never yield to us. Pictures, embroideries, manuscripts, such as constitute his hoard, even if they had been buried in the graves, would have been destroyed by damp in much less than a thousand years. His finds in the bone-dry caves of the Thousand Buddhas form the necessary complement of what excavation has yielded from China itself, with the result that we have in England what is probably a unique mass of material for the study of Chinese archaeology, religion, and art during the three centuries preceding the Norman Conquest."

**THE PILTDOWN SKULL.**—Since the discovery of fragments of a human cranium and jawbone at Piltown in Sussex in 1912 a fierce controversy has raged over these interesting remains. The recent contributions to the discussion are reviewed by Mr. E. N. Fallaize in the July issue of *Discovery*. As regards the question of dating, he remarks that the claim of its identification as a specimen of Pliocene man must be held not to be proven. As to the character of the skull, a fresh reconstruction of it has recently been made by Profs. Elliot Smith and Hunter, generally confirmatory of earlier reconstructions of Dr. Smith Woodward and Mr. Pycraft. It is low and broad and of a capacity less than 1300 c.c. It differs, however, in one important respect. The occipital fragment, which determines the shape

of the back of the skull, assumes a more vertical position, and produces a form more nearly resembling the anthropoid skull than that of modern man. The result is a skull like no other skull, but its similarity to the Simian skull brings it into complete harmony with the chimpanzee-like jaw. The difficulty of the discrepancy between cranium and jaw has thus been cleared up, while the endocranial cast, as might be expected, takes its place between that of *Pithecanthropus erectus*, the fossil skull from Java, and that of the recently discovered Rhodesian Man.

**PALÆOZOIC BRACHIOPODA FROM EASTERN ASIA.**—Two parts of a paper, which constitute a portion of the attempt of the Geological Institute in Sendai (Japan) to contribute to the knowledge of the geology of Eastern Asia, are contained in the Science Reports of the Tōhoku Imperial University, Sendai (Second Series: Geology, vol. vi. No. 1). In these, Ichirō Hayasaka discusses the palæozoic Brachiopoda from Japan, Korea, and China. The majority of forms are referred, although occasionally doubtfully, to species well known from the same strata in other parts of the world, but in one case the author has felt justified in establishing a new genus, *Athyrisina*, for two Middle Devonian species, also new. The seven photo-lithographic plates are good, but sometimes wanting in clarity; more exact illustration would have been especially acceptable in the case of the new genus and its species.

**MIMICRY AMONG BIRDS.**—Mr. G. T. Harris, Buckereil, East Devon, has sent us a description of a robin attacking a cuckoo. The latter species is frequently harassed by single small birds in this way, or is "mobbed" by a band of them. At first sight this might seem to indicate resentment of the cuckoo's parasitic habits, but it is probably going too far to credit the victimised species with so intelligent an awareness of the position: for although the chosen foster-parents will try to drive off a cuckoo about to lay in their nest, they will subsequently hatch the egg and rear the young parasite in a way which shows that they have indeed no understanding of the trick which is played upon them. A more credible explanation is to be found in the cuckoo's similarity to a hawk, for small birds will "mob" hawks and owls in much the same way when they can get these birds-of-prey at a disadvantage. The cuckoo is a comparatively weak bird, and its mimicry of a hawk is doubtless useful both in regard to its peculiar breeding habits and otherwise, although at times it entails the unwelcome attentions referred to above. This interesting mimicry is probably to be regarded as a definitely evolved adaptation: the alternative explanation of mere coincidence might perhaps be urged if there were not numerous other examples to show that such mimicry is quite possible. There is an Indian cuckoo, for example, which habitually victimises a drongo as a foster-parent and closely resembles that species in outward appearance. Again, there is the striking case of the friar-birds and orioles of the Malay Archipelago: here the weak orioles appear to gain an advantage in the struggle for existence by their close mimicry of the pugnacious friar-birds. Moreover, there are several species of friar-birds on different islands, and for each there is an appropriate oriole. Among insects, too, there are many good examples of the mimicry of one species by another and unrelated form.

**EARTHQUAKES IN THE REGION AROUND TOKYO.**—Prof. Omori contributes to the second number of the new journal, *Seismological Notes*, an interesting paper on the Tokyo earthquake of December 8, 1921, the strongest experienced in that city since 1894, though resulting in only slight damage to buildings. The shock was notable for its extraordinary duration, having been sensible for three minutes. The position of the epicentre, as determined by the duration of the preliminary tremors at Tokyo, Mito and Choshi, is 58 kms. N. 65° E. of Hongo (Tokyo). The actual distance of the focus from the latter place was, however, 65 kms., leading to the conclusion that the depth of the focus was about 29 kms. or 18 miles. Prof. Omori also considers the distribution of Tokyo earthquakes in space and time. Those of the eight years 1914–1921 originated for the most part in four regions, three of them at a mean distance of about 35 miles from Tokyo, the district surrounding the capital being at present immune, and the fourth a submarine zone off the eastern coast of the Main Island. The curve of annual frequency beginning with the year 1876 resembles so closely the curve of mean precipitation at Niigata and Akita (places in the Japan Sea region with an abundant snowfall) as to suggest the probability that the precipitation on the north-west side of the Main Island may be one of the secondary causes that determine the frequency of earthquakes felt in Tokyo.

**AURORAL MEASUREMENTS.**—In No. 8, vol. ii, *Geofysiske Publikationer* of the Norwegian Geophysical Commission, Prof. Karl Störmer gives further results of his auroral measurements. As a check on the accuracy of his methods, he deals with simultaneous observations taken on March 22, 1920, at Christiania, Kongsberg and Frederikstad. Combining the stations in pairs, he gets three sets of results derived from three differently oriented bases, having lengths of approximately 66, 79, and 89 kilometres. The heights of three selected auroral points are calculated in two different ways. As the accuracy seems much the same for the two methods, it will suffice to give the results of the first. The means of the heights calculated for the three points were 143, 177, and 214 km., and the differences between the highest and lowest of the three estimates from the three bases were respectively 5, 5, and 7 km. A second chapter deals with observations on the height and position of an auroral arc determined from observations with a base of 258.5 km. As seen from the southmost station, near Christiania, the arc was near the horizon. It was overhead at a point situated about 700 km. to the north-west. Besides diagrams in the text there are eight large plates, the first two referring to the cases described above. The others are selected as among the finest auroras which Prof. Störmer has yet photographed. In some cases difficulty may be experienced in deciding which is the top and which is the bottom of the picture. This might with advantage have been stated in words on the plates.

**THE NEW MAGNETIC ATOM AND ITS PROPERTIES.**—In order to improve his original theory of magnetic induction in ferromagnetic materials, Sir J. A. Ewing published in February his theory that the magnetic element is not the atom itself but something smaller which can rotate within the atom. It may be likened to a wheel with a number of like poles on its rim and the poles of opposite kind at its centre. Around it is a fixed ring provided with magnetic poles, under the action of which the wheel may take up a number of positions of equilibrium. Two months later, Prof. E. T. Whittaker showed that a

model of this type when approached by an electron with kinetic energy exceeding a certain amount  $U$ , would take from it an amount  $U$  depending on the electronic charge and on the constants of the model, and that if  $n$  is the frequency of the oscillations of the model and of the radiation it emits, then  $U = hn$  where  $h$  is the constant of the quantum theory. More recently Dr. H. S. Allen has pointed out that such a vibrator would not lead to the equipartition law, and Dr. R. A. Houston has shown that for the model to vibrate with the frequency of sodium light its diameter must be  $2.7 \times 10^{-8}$  cm. and with X-ray frequency  $3.5 \times 10^{-10}$  cm. which agree well with the known diameter,  $2 \times 10^{-8}$  cm. of the hydrogen atom. The four papers mentioned will be found in the Proceedings of the Royal Society of Edinburgh.

**STRUCTURE OF ABRADED GLASS SURFACES.**—A series of papers issued from the Research Department of Messrs. Taylor, Taylor and Hobson, Ltd., and published in the current number of the Transactions of the Optical Society, provide a valuable contribution to our knowledge of the physical nature of the processes involved in the workshop operations of cutting and grinding, particularly of hard brittle substances. Detailed photomicrographic studies of the structure of ground glass surfaces and of the flaws produced in glass by various means lead the author, Mr. F. W. Preston, to the conception of a flaw and fissure complex rather than the current view of a hill and hollow structure as characterising a ground surface in brittle materials. His experiments show that in polishing as well as in grinding, the forces of mechanical abrasion are active, although in the former case they tend to be obscured by surface tension effects. During polishing the whole of the flaw complex previously formed is broken away from the roots and a slight molecular rearrangement of the new surface then takes place, as observed by Beilby, who has demonstrated the existence on all polished surfaces of a flowed (surface tension) layer. The enhanced solubility of ground surfaces in hydrofluoric acid, and also the appearance of the structure of polished surfaces as developed by etching, suggest a low value for the thickness of this surface tension layer—in the case of glass some two or three millionths of an inch at the most.

**REPEATING PATTERNS AS DECORATIONS.**—The Journal of the Royal Society of Arts for June 30 contains an interesting paper by Major P. A. MacMahon on the design of repeating patterns for decorative work. Major MacMahon has recently investigated the modes of dividing flat space into identical figures without gaps or overlapping. Such divisions are familiar to every one in wall paper designs, which are generally formed by cutting up the plane first into identical parallelograms. More complex types of repeating pattern were designed in very early days and some of them still survive in ancient tessellated pavements. The method of classification obtained by Major MacMahon has proved wide enough to place every such design brought to his notice, and he has reasons for thinking that it is exhaustive. He reports that at least 90 per cent. of the few hundreds of categories have apparently never been drawn upon for practical application. The paper is illustrated by a few specimen patterns, some of which are sufficiently remarkable to merit close attention from those engaged in decorative work. An interesting fact, which does not appear to have been generally recognised before, is that a plane can be completely filled with congruent quadrilaterals of any shape.

## Leicester Conference of the Museums Association.

THE thirty-third annual conference of the Museums Association, held on July 10-15 at Leicester, under the presidency of Mr. E. E. Lowe, director of the Museum, Art Gallery, and Libraries in that city, was attended by eighty-six members, comprising delegates from most of the leading museums, national and provincial, in the British Isles, as well as from Canada and the United States. The admirably organised hospitality of an influential reception committee rendered the meeting one of the most enjoyable in the history of the Association; and the devoted labours of its experienced president with his helpers, in their endeavours to make up for the regretted absence of the secretary, Dr. W. Tattersall, through illness, led to an unusual smoothness of working. Above all, the papers and discussions were thoroughly practical, and seemed likely to produce valuable results.

The president divided his address into a more popular part, for the benefit of the local dignitaries and other friends who attended the opening meeting, and a more technical part addressed to the members of the Association alone. This is an example that might sometimes be followed elsewhere. The first part showed how romance could be extracted from the objects in a museum and used to make more effective contact between the museum and the public. The second part suggested a means by which the Association might undertake more constructive work than it had previously been able to accomplish, and by which members other than the officers and council could take a more continuous and active share in the life and labours of the corporate body. This was the establishment of sub-committees, similar to those of the British Association, to conduct inquiries during the year and to report through the executive to the annual meeting. The proposal was taken up by the Council and welcomed by the meeting. Three such sub-committees were appointed to investigate matters already laid before the conference. Thus Mr. E. Rimbault Dibdin's paper on the organisation of picture exhibitions in the provinces led to the appointment of a committee to consider his proposals. A second committee, arising out of a demonstration by Mr. E. Howarth, is to report on the cleaning and restoration of pictures. The third committee is to investigate and report upon preservative solutions and upon cements for use with various preservatives. This committee, as at present constituted, comprises Dr. W. E. Hoyle (chairman), Dr. G. Hay Murray, and Dr. J. J. Simpson (secretary), and will doubtless welcome assistance from every quarter. The last two gentlemen presented to the meeting notes and demonstrations on cements and labelling for spirit specimens.

Other practical communications included a demon-

stration by Sir Sidney Harmer of his researches on the fading of museum specimens, illustrating his important paper published in a recent number of the *Museums Journal* and previously noticed in these columns; a paper and demonstration on taking squeezes of fossils by Dr. F. A. Bather; and a paper on museum labelling and printing, by Mr. A. T. Roberts, head of the Leicester School of Arts and Crafts. Leicester is famous for its printing and lettering, and the labels in the Leicester Museum admirably exemplify the influence of this school, while the exhibitions held there from time to time help the business community to improve the style of advertisement. Mr. Loney, of the Norwich Museum, recounted his success in obtaining money for museum purposes through an organisation known as "Friends of the Museum"; Mr. R. W. Brown, of Northampton, made sound suggestions on mutual co-operation between museums and public libraries; Mr. Williamson, of Derby, discussed the classification of Derby porcelain; Prof. Parks, of Toronto, described the constitution of the Royal Ontario Museum; and Mr. R. F. Martin reported on the Buffalo meeting of the American Museums Association which he had attended. Mr. J. Bailey urged the appointment of a Royal Commission "to investigate and report upon the work of museums of the United Kingdom in relation to industries and general culture" and his proposals, endorsed by a large meeting, were subsequently adopted by the council.

In connexion with the conference there were arranged at the museum an exhibition by the British Institute of Industrial Art, an exhibition of wood-grain panels, executed by Mr. A. J. Rowley, after designs by well-known artists, and a number of modern paintings lent by artists of international reputation. Bearing more directly on the work of the Association were two rooms filled with exhibits by members and by fifteen business firms, all of which attracted the constant attention of the delegates and other visitors throughout the week. But perhaps the most illuminating and inspiring exhibit was the Leicester Museum itself, not so much for the building or the specimens contained in it as for the prevailing sense of life and directing intelligence. The numbers that thronged the galleries on Sunday afternoon and the cordial assistance of the Mayor and many members of the corporation showed how highly the people of Leicester appreciate a museum and a director of whom they may well be proud. In doing so they prove how true are the principles for which the Museums Association and notably its retiring president have never ceased to strive.

The next conference will meet at Hull in July 1924, under the presidency of Mr. Thomas Sheppard.

## The Arrangement and Motion of the Sidereal System.

THE above is the title of the late Prof. Kapteyn's last paper, which appeared in the *Astrophysical Journal* for May. In an earlier paper he had shown that the surfaces of equal stellar density are approximately ellipsoids of revolution, modified, however, by inflexions near the pole. In the present paper he assumes the exact ellipsoidal form, for convenience of computation, though admittedly not quite in accord with fact. He draws ten ellipsoids, embracing the known portion of the stellar system; the semi-minor axes (towards the galactic pole) range from 118 to 1660 parsecs, while the radii of the circular galactic sections are in each case 5.1 times the polar semi-axes. The logarithms of the star-density in the successive shells fall off from 9.80 in the inner to 8.00

in the outer, the density in the sun's neighbourhood being the unit. For simplicity the sun was taken as central; its most probable distance from the centre is given as 650 parsecs, the latter lying in R.A.  $23^{\text{h}} 10^{\text{m}}$ , N. Decl.  $57^{\circ}$ ; this is not far from Kapteyn's 1893 position, which was R.A.  $0^{\text{h}}$ , N. Decl.  $42^{\circ}$ . Kapteyn noted that his work would need correction for this eccentric position of the sun, and also for the fact that he combined stars of all spectral types together, though it is known that there are systematic differences in their motions.

The convenience of assuming that the successive shells are ellipsoids is that each shell exerts no attraction on the space within it, and if there are other similar shells outside the outermost one considered,

these will have no effect. Assuming that there are no dark stars or bodies the average masses of the stars are found to fall off from 2.2 near the sun to 1.4 in the outer regions. The mean is 1.6, practically the same as Jackson and Furner found from a study of binary stars. This seems to show that the amount of dark matter in the system is relatively small; we may infer that the duration of the system in the past is not greatly longer than the luminous period of individual stars. The two star-drifts are ascribed to rotational movements of the stars in opposite directions about the galactic polar axis, an idea that was also suggested by Eddington in the Jubilee Number of *Astronomische Nachrichten*.

Kapteyn shows that the supposition explains not

only the observed directions of the drifts but also their numerical amounts, namely, 40 km./sec. for the relative velocity of the drifts. It is noted that if the drifts are really due to circular motion the more distant stars should give somewhat different apices from the nearer ones. This will afford a test of the theory.

Some preliminary statistics based on the study of the "Selected Areas" were used in the paper; when these data are fully available it will be possible to give improved values of the star-density in the outer regions. The paper is noteworthy as being one of the earliest attempts to explain dynamically all the star-movements in the system; while avowedly only approximate, it supplies a foundation on which more exact researches may be based.

### The Oil Palm in French West Africa.<sup>1</sup>

THE resources of the French possessions in West Africa in oilseeds and nuts are practically inexhaustible, and considerable attention is now being given by the colonial authorities to the possibility of greatly increasing the supplies of these valuable products by scientific research, particularly in the direction of plant-breeding and selection, and the most up-to-date methods of cultivation. In collaboration with the Institut Colonial de Marseille the Governor-General of French West Africa is establishing research stations and experimental plantations in Dahomey and on the Ivory Coast, chiefly for oil-palm study, but work on the cotton plant and ground-nut (arachis) will also be included. It is estimated that, with proper methods, 300,000 tons of palm oil per annum could be obtained from the Ivory Coast alone. Two oil-palm experimental stations have been already planned, and a chemical and botanical staff is being engaged for the work under M. Teissonnier, Director of Agriculture of the Ivory Coast.

The programme of research both at Bingerville and at Dakar will include primarily the improvement of oil-palm varieties, and more particularly the evolution by selection of a variety which will give a maximum yield of palm oil. The aim therefore is to increase the pulp or pericarp at the expense of the kernel, since it is held that palm oil is of more value than palm kernel oil, and is likely to be still more so if the present research work on the production of an edible palm oil is completely successful. The best varieties at present known, *e.g.* Pisifera and Ceredia (A. Chevalier), will be used as a starting-point, and it is hoped by judicious selection, breed-

<sup>1</sup> Bull. des Matières Grasses de l'Inst. Col. de Marseille, 1921, 9 and 10, 145-158.

ing, and proper cultivation in plantations, instead of happy-go-lucky native methods, to increase largely the yield of palm oil, and also improve its quality to such a degree that an edible grade can be obtained without the need of any subsequent chemical refining. Another important aim is to achieve a variety which will mature early. At present an oil palm in West Africa must be about five years old before commencing to bear fruit, although in the Dutch East Indies (east coast of Sumatra) they are reported to come into bearing at three years. On the other hand, in the East Indies, the seed takes much longer to germinate—six to nine months as compared with five or six weeks in West Africa.

The possibilities of plant research in connexion with many important economic products are now realised, and these experiments in French West Africa will be watched with interest, although, of course, some years must elapse before certain and definite results can be obtained.

Reference has been already made to the Dutch East Indies, where similar work has been undertaken both in Java and in Sumatra for many years. Doubtless also the big English firms interested in African palm oil are fully alive to the importance of this kind of research, and as a matter of fact they initiated experimental plantations years ago, but no results have been published, for obvious reasons.

The East Indies and also Malaysia have now entered the lists as serious rivals to West Africa in supplying the world with oil-palm products, and in some respects they seem to have an advantage over West Africa, but assuming that natural conditions of soil and climate are approximately equal, the deciding factor will be the success or otherwise of these plant-breeding experiments.

### The French Dye Industry.

THE issue of *La Nature*, April 15, contains an interesting summary of the French dyestuff industry, particular attention being paid to progress made since 1914. In 1913, 2000 tons of dyes, of the value of seven million francs, were imported. Eighty-five per cent. came from Germany and ten per cent. from Switzerland. The balance of the consumption of 9000 tons represented French manufacture. It is pointed out, however, that the dyestuff factories of France, of which there were four, were almost completely dependent on Germany for intermediates, the home production of which represented scarcely ten per cent. of the requirements. There were in addition German works which received intermediates or even finished dyes from Germany. The article refers to

the ready adaptation of the dye works in Germany to the manufacture of munitions during the war, and does not omit to point out that, without the means of obtaining synthetic nitric acid, which the enemy had also perfected, his dye works would not have been of the slightest use to him.

The French efforts during the war are described at length. In April 1916 the Syndicat National des Matières Colorantes was established, which had relations with the State and further arranged to take over after the war the national factories used in the manufacture of explosives. The Compagnie National des Matières Colorantes et de Produits Chimiques was constituted in January 1917 and at once set to work. Two factories rapidly grew up, the first at Nogent-

les-Vierges on a semi-technical scale, and a large factory at Villers-St-Paul, with a contemplated capacity of 4,000 tons of synthetic indigo a year. This was abandoned during the German advance in 1918 and the material removed to Lyons, but it has again been set in operation, and as a result of intensive work, the total production of the French factories had grown from 175 tons in 1919 to 765 tons in 1920. Since that time the production has decreased on account of the economic crisis, although the capacity of production is now stated to exceed 13,000 tons. With a few exceptions, dyes of all the main types are manufactured and progress is being made.

The company has two large centres of production. The Oissel Works, installed at the old national factory, with an area of 39,000 sq. m. of buildings, is connected with the main line from Paris to Rouen. The power is generated by turbo-alternators of the most modern type, each of 1000 kilowatts. The factory is at present making intermediates, of which more than sixty are being produced, together with sulphur dyes and azo-dyes. These are produced directly from the intermediates without isolation of the latter from solution.

The second works is that at Villers-St-Paul, with an area of 35,000 sq. m. of buildings, on the main line from Paris to Compiègne. A very modern boiler plant is installed, which when complete will consume 300 tons of coal daily. In this works are made the dyes which require special apparatus, such as indigo and alizarine, phthalic acid and basic dyes derived from it, triphenyl and diphenylmethane dyes, pyrazolone dyes, etc. Vat dyes are also made, and there are large research laboratories.

At Saint-Denis the old works has been enlarged, while a new works at Isère grew up during the war. It is stated that prices are now high owing to high costs of raw materials, and the yields could also be improved by the further efforts of the chemists, and particularly of the engineers.

### The Metallic State.

RECENT advances in our knowledge of the structure of the atom have added very little to the elucidation of the nature of the metallic state, and in this connexion a very suggestive paper by Prof. C. A. Kraus, in the June number of the *Journal of the American Chemical Society*, will be of interest. According to modern views the metals owe their characteristic properties to the presence of negative electrons free to move within the body of the metal. Electronegative elements, such as chlorine, owe their characteristic property of forming anions to the fact that they are capable of forming stable complexes (the ions) with one or more negative electrons. Metallic properties may be expected only in such substances as do not contain sufficient electronegative elements to engage the negative electrons supplied by the more electropositive constituents, or otherwise, in which electronegative elements are lacking. The smaller the affinity of an element or group for the negative electron, the more electropositive will it appear, and the more readily will it enter into reaction with more electronegative elements.

The association of negative electrons with positive metallions, which is supposed to make up the structure of a metal, has some resemblance to a salt. At very low concentrations the negative electron may no longer possess the freedom of motion characteristic of the metallic state, and it is known, for instance, that mercury vapour is a very poor conductor. The metal may under such conditions exhibit salt-like

properties, and intermetallic compounds may also show resemblances to salts. There are many such compounds which have properties in harmony with this view. The more electronegative elements in such compounds are supposed to have a negative charge. The compound  $\text{Na}_3\text{Sb}$  is then similar to  $\text{Na}_3\text{N}$  or  $\text{Na}_3\text{P}$ . The question is raised whether the apparent deviations of intermetallic compounds from the valency relations may not be due to the tendency of electronegative elements to form complexes. This is shown in the compounds  $\text{NaN}_3$ ,  $\text{KI}_3$ , etc., and it is suggested that something of the kind occurs in such compounds as  $\text{Na}_4\text{Sn}$ ,  $\text{Na}_2\text{Sn}$ ,  $\text{Na}_4\text{Sn}_2$ ,  $\text{NaSn}$ , and  $\text{NaSn}_2$ . The atoms in such complexes, however, may not all function in the same manner. The property of metallicity is not an atomic one; it is due to the negative electron, and the rôle of the positive constituent is a secondary one.

Many reactions in liquid ammonia solution, and the existence of substituted ammonium amalgams and substituted ammonium radicals in liquid ammonia solution, support the views expressed. As an example it is stated that tellurium reacts with a solution of sodium in liquid ammonia to form a white crystalline precipitate of the typical salt-like compound  $\text{Na}_2\text{Te}$ . On further addition of tellurium this goes into solution with the production of complex tellurides,  $\text{Na}_2\text{Te}_2$  and  $\text{Na}_2\text{Te}_4$ , which form strongly coloured solutions, similar to those of alkali-metals, and when precipitated from solution exhibit metallic properties.

### University and Educational Intelligence.

LONDON.—At a meeting of the Senate on July 19, Dr. J. C. Drummond was appointed to the University chair of biochemistry tenable at University College. Dr. Drummond graduated from East London College with first-class honours in chemistry, and has been research assistant in the Physiological Laboratory at King's College and assistant analyst in the Government Laboratory (Foods Department). He has also conducted research work at the Cancer Hospital, and has been since 1920 University reader in physiological chemistry at University College.

PROF. ADRIAN STOKES was appointed to the Sir William Dunn chair of pathology tenable at Guy's Hospital Medical School. Prof. Stokes has held the posts of assistant to the professor of pathology at Dublin University and pathologist to the Royal City of Dublin Hospital, while since 1919 he has been professor of bacteriology and preventive medicine at Dublin University. Two years ago he worked with the Rockefeller Commission on Yellow Fever in Nigeria.

The following doctorates were conferred:—*D.Lit.*: Mr. W. I. Moore, King's College, for a thesis entitled "Education and Social Systems, English and French: A Study of Educational Effort and Opinion 1750-1810"; *D.Sc.*, in *Botany*: Miss Dorothy Haynes, King's College and the Imperial College—Royal College of Science, for a thesis entitled "(1) Electrical Conductivity as a Measure of the Content of Electrolytes of Vegetable Saps, and (2) the Action of Salts and Non-electrolytes upon Buffer Solutions and Amphoteric Electrolytes and the Relations of these Effects to the Permeability of the Cell"; *D.Sc.*, in *Physics*: Mr. W. E. Curtis, King's College, for a thesis entitled "The Structure of the Band Spectrum of Helium"; Mr. B. A. Keen, University College, for a thesis entitled "The Physical Properties of Soil"; Mr. F. H. Newman, for publications entitled "Active Modification of Hydrogen and Nitrogen produced by

X-rays," "A New Form of Wehnelt Interrupter," and other papers; Mr. H. R. Nettleton, for a thesis entitled "On the Absolute Measurement of the Thomson Effect," and other papers. *D.Sc. (Engineering)*: Mr. Herbert Moss, the Imperial College—Royal College of Science, for a thesis entitled "Air Consumption and B.H.P. of Aero-Engines."

Mr. H. G. WELLS has accepted the invitation of the Labour Party of the University of London to offer himself as the candidate of the Party at the election for a representative of the University in the House of Commons to be held after the retirement of Sir Philip Magnus at the end of the present session of Parliament. Mr. Wells occupies such a distinguished position in the world of literature and among leaders of thought to-day that his early work in science and education is often overlooked. He was a student at the Royal College of Science, South Kensington, in 1884-87, and was the first president of the Old Students' Association of the College. He took his B.Sc. degree with honours in zoology in 1890, and his first book was a "Text-book of Zoology," written particularly for London University students while he was a teacher of the subject. He is a fellow of the College of Preceptors, and for a short time edited the *Educational Times*. Throughout his career he has been a steadfast supporter of scientific methods in schools and government, and in his books has pleaded the cause of scientific education and research with eloquence and conviction. It is not too much to say that no graduate of the University of London possesses such a rare combination of brilliant literary power and scientific thought or has used these gifts with greater effect than has Mr. Wells in his many and various works.

It is announced in *Science* that by the will of Seymour Coman, of Chicago, the University of Chicago is made trustee of his residuary estate, about 29,000*l.*, the net income from which is to be used for scientific research with special reference to preventive medicine and the cause, prevention and cure of diseases. The bequest is to be known as the Seymour Coman Research Fund. By the will of Alexander D. Thomson, of Duluth, Minnesota, the sum of 20,000*l.* is bequeathed to the University of Minnesota for use in the medical department. It is also stated that Wake Forest College School of Medicine, North Carolina, is entitled to receive the principal of a trust fund, amounting to 275,000*l.*, which was created in 1892 by Jabez A. Bostwick, a director of the Standard Oil Company.

A SUMMER course in the Austrian Tirol of unusually wide interest is being organised by the directors of Leplay House, 65 Belgrave Road, Westminster, S.W.1. The course will be of the nature of a civic and rustic survey, and for this purpose the party will be divided into groups each of which will take one particular aspect of the work. Mr. H. J. E. Peake, president-elect of the Anthropological Section of the British Association for the Advancement of Science, has undertaken to direct the group studying the anthropological aspects; Dr. M. Hardy will organise a survey of plant life and agriculture, while other sections will deal with the geology, physiography, history and sociology of the district. Group meetings and gatherings of the whole party will frequently be held for the purpose of discussing and comparing results, which when assembled and collated should provide a valuable record of natural conditions and life in the Tirol. The tour will commence on August 4 and will last four weeks, although it is possible to arrange for a shorter course of two weeks.

## Calendar of Industrial Pioneers.

**July 31, 1884. Charles Manby died.**—The eldest son of Aaron Manby, one of the pioneers of iron ship-building, Charles Manby was engineer of the first iron steamer which crossed the English Channel, and after gaining experience in his father's gas and iron works in France returned to England, and from 1839 to 1856 rendered valuable services to the engineering world as secretary to the Institution of Civil Engineers.

**August 2, 1910. Oscar Guttman died.**—Hungarian by birth, Guttman became editor of an Austrian mining journal, practised on the continent as a chemical engineer, and eventually settled in England, where he erected several works for the manufacture of explosives. He wrote and lectured on explosives, on which he was a recognised authority, and was elected a vice-president of the Institute of Chemistry.

**August 3, 1792. Sir Richard Arkwright died.**—Born at Preston, December 23, 1732, four years before Watt, Arkwright was responsible with Watt for the great industrial developments in England in the latter part of the eighteenth century which enabled this country to withstand the tremendous drain on her resources due to the Napoleonic wars. Starting life as a barber, Arkwright became a hair merchant, and about 1767 gave himself up to inventions in cotton spinning. Two years later he patented his "spinning frame," "the first adequate example of those beautiful and intricate mechanical contrivances which have transformed the whole character of the manufacturing industry." He is also regarded as the founder of our factory system.

**August 3, 1880. Mungo Ponton died.**—A Writer to the Signet and a founder of the National Bank of Scotland, Ponton through ill-health retired from business and devoted himself to science. In 1839 he made the important discovery that the action of the sun renders bichromate of mercury insoluble.

**August 3, 1906. Sir Alexander Moncrieff died.**—Educated at the universities of Edinburgh and Aberdeen, Moncrieff became an officer in the Forfarshire Militia and saw active service in the Crimean war. He afterwards became known as the inventor of the Moncrieff disappearing gun-carriage and the hydro-pneumatic system of recoil.

**August 4, 1921. Samuel Alfred Varley died.**—A member of a famous family of electricians and one of the pioneers of the dynamo, Varley made numerous experiments on submarine telegraph cables. In 1866 he made a self-exciting dynamo with soft iron magnets, and ten years later patented the compound-wound dynamo.

**August 5, 1729. Thomas Newcomen died.**—A native of Dartmouth and born in 1663, Newcomen is believed to have been a blacksmith. He became associated with Thomas Savery in his attempts to use steam for pumping, but it was Newcomen's own great invention of the atmospheric steam-engine which furnished the model for pumping engines during the eighteenth century. His first engine appears to have been erected at Dudley Castle in 1712. Newcomen died in London and was buried in Bunhill Fields.

**August 5, 1876. James Freeburn died.**—Freeburn enlisted in the artillery in 1825 when seventeen years of age, and rose to the rank of sergeant-major. Turning his attention to the exploding of shell he brought out a series of metal and wood fuses for time or percussion which, after various improvements, were adopted. Freeburn after thirty years' service was retired with the rank of honorary captain.

E. C. S.

## Societies and Academies.

LONDON.

**Geological Society**, June 28.—Prof. A. C. Seward, president, in the chair.—C. E. Tilley: The petrology of the metamorphosed rocks of the Start Area (South Devon). The rocks of the Start area comprise a group of mica- and quartz-mica-schists, together with a great development of green schists of basic composition. They can be divided into lower mica- and quartz-mica-schists, green schists, and an upper group of mica- and quartz-mica-schists. The field relations of these rocks show that the dominant feature of the area is an anticlinorium with an axis plunging westwards. The rocks are sharply differentiated from the slates and phyllites of Devonian age in the Kingsbridge area immediately to the north; the two areas are probably separated by an important boundary of dislocation. The aluminous sediments are typically quartz-muscovite-chlorite types, the grade of metamorphism corresponding to the formation of biotite not being reached. In the composite type of sediment, where tuffaceous material is included, the highest stage of metamorphism is reached in the muscovite-chlorite-garnet-albite-schists. The garnet is rich in the spessartine molecule, and the reversal of the normal biotite-garnet order in an increasing grade of metamorphism is ascribed to the presence of manganese.—A. R. Derryhouse: The glaciation of the counties of Antrim, Down, and parts of Armagh, Londonderry, Tyrone, Monaghan, and Louth in Ireland. The deposits consist of boulder-clay, gravel, and sand, and are divided into two groups according to their direction of transport: those derived from the north-east and carried by a glacier which flowed by way of the Firth of Clyde from Scotland; and those the source of which lay to the west, carried by an Irish ice-sheet having its origin in Donegal. The former are characterised by the riebeckite-bearing rock of Ailsa Craig with granites, quartz-porphry, and pitchstone from Arran; the latter contain boulders of igneous rocks from County Tyrone. Delta-terraces and overflow-channels show that ice-dammed lakes existed in the district. Moraines occur, the most conspicuous being those near Armo in Antrim and near Garvagh in Londonderry. The earlier glaciation was effected by the ice from Scotland, which reached south-west to the town of Monaghan and the eastern flank of Slieve Beagh. The Scottish ice was then gradually replaced by that from Donegal. The latest phase of the glaciation was a second advance of the Scottish ice, which formed definite frontal moraines in the neighbourhood of Ballymoney and Armo, and the establishment of a small local centre of glaciation in the neighbourhood of Trostan, the highest mountain in County Antrim. Glaciation was probably continuous.

DUBLIN.

**Royal Dublin Society**, June 27.—Dr. J. A. Scott in the chair.—H. H. Jeffcott: The electrical design of A.C. high tension transmission lines. A method is given for calculating the performance of high tension transmission lines, based on direct evaluation by complex quantities. The process can be systematised into an arithmetical routine. Examples of its application to specific problems are given.—T. Dillon, Rosalind Clarke, and V. M. Hinchy: Preliminary experiments on a chemical method of separating the isotopes of lead. Lead chloride containing thorite lead was treated with magnesium ethiodide and the resulting lead tetraethyl and metallic lead were re-converted into lead chloride. This material was treated with magnesium ethiodide and comparative atomic weight determinations of

the lead from the two fractions of lead chloride obtained showed a difference of atomic weight of 0.2 to 0.3.—T. Johnson and J. G. Gilmore: (1) The lignite of Washing Bay, Co. Tyrone. Lignite was found at various depths, but especially at 1000 ft., in the Washing Bay core. It is all coniferous in nature and is referred to *Sequoia Couttsiae*, Heer, of which cones, seeds, and foliage have been previously described from the same beds. The Lough Neagh lignite originally described by Unger as *Peuce Prichardi* may prove to be a *Sequoia* also. (2) *Libocedrus* and its cone in the Irish Tertiary. A foliage impression of *Libocedrus salicornioides* showing characteristic stomata and epidermal papillae is described. The specimen was found at a depth of 904 ft. in the clay core of the coal-bore at Washing Bay, Lough Neagh. The foliage shoots and cones of the same species from the interbasaltic beds of Ballypalady, Co. Antrim, are also described, the specimens being preserved in the Belfast Museum. Restorations of the wood show agreement between the Irish material and that from Leoben in Styria and with recent *Libocedrus*, of which *L. decurrens* (California) and *L. chilensis* are the nearest living representatives.

PARIS.

**Academy of Sciences**, June 26.—M. Emile Bertin in the chair.—P. A. Dangeard: Researches on the structure of the cell in the iris. In an earlier communication the author has suggested that the term chondriome really comprises three different types of elements named vacuome, plastidome and spherome. This is confirmed by a study of the leaf of *Iris germanica*. The structure is best observed on unstained specimens. Fixing and staining methods are liable to cause distortion, and have, in the author's opinion, led to erroneous interpretations of the cell structure in the past.—J. Costantin: Acquired heredity. The wild potato is a mountain species, growing in the Andes up to 4000 metres, and the formation of tubercles is caused by a fungus. In the absence of this fungus, the hereditary characters can be maintained intact only if the plant is maintained under the climatic conditions which it requires. Thus the variety "Up to date" degenerates in Algeria, but has been maintained without change for twenty-five years in Scotland.—Pierre and Louis Bazy: Vaccination before operation. Preventive auto-vaccination is suggested as preferable, except in cases requiring immediate operation, to preventive serotherapy.—Maurice d'Ocagne: Transparent nomograms.—A. Rateau: Calculation of the variations of the level of an aeroplane due to a variation of its weight or to the use of a turbo-compressor.—Henri Jumelle: The group of *Chrysalidocarpus lutescens*.—M. Amé Pictet was elected correspondent for the section of chemistry in the place of the late Prof. Ph. A. Guye.—H. Mineur: Certain functional algebraical equations.—Torsten Carleman: The problem of moments.—Paul Lévy: The law of Gauss. Correction of an error in an earlier note (March 27).—W. Margoulis: Transparent abacus with orientation.—Gaston Bertrand: The law of Riemann, the perihelion of Mercury, and the deviation of light. Measurements of high precision are necessary to decide between the formulae of Einstein and Riemann.—Charles Nordmann and Le Morvan: Observations of stars of the N type and especially of a star with a very low effective temperature, by means of the heterochrome photometer of the University (Paris). One of the three stars examined (112, 559, Henry Draper Memorial Catalogue) has an effective temperature of 2160° absolute (1887° C.), the lowest temperature of any star measured.—N. Vasilesco Karpen: A new evaluation of the internal

pressure of liquids. The criterion of the association of the molecules in a liquid.—B. Szilard: The direct estimation of very small quantities of radium by the penetrating rays. An application of the portable electrometer described in a previous paper (June 19). Using 500 grams of material containing  $10^{-9}$  grams of radium per gram, the error of estimation is within 2.5 per cent.—Paul Pascal: Magnetochemical research on the constitution in mineral chemistry. Acids containing arsenic.—G. Gire: The dissociation of barium chloroplatinate. The dissociation pressures of this salt were measured at temperatures ranging between  $428^{\circ}$  C. and  $665^{\circ}$  C., and the heat of reaction calculated.—A. Demolon: The accessory elements in Thomas slag. Besides phosphate, basic slag contains lime, magnesia and manganese. Determinations of the solubility of the slag in various solvents (water, sugar-solution, carbolic acid, etc.) have been made and the results given as curves with time as abscissa.—L. J. Simon: Oxidation by mixtures of sulphuric acid and chromates. The use of silver chromate with sulphuric acid gives a more complete combustion of organic compounds than alkali chromates and sulphuric acid. The modification is especially useful in the analysis of bodies containing the acetyl group.—Mlle. Hélène Billon: The action of trimethylene chlorobromide on some ketones of the fatty series.—R. Locquin and Sung Wouseng: The transformation of the tertiary ethylenic alcohols (linalol type) into primary ethylenic alcohols (geraniol type).—F. Kerforne and L. Dangeard: The palaeozoic rocks brought up by the dredge of the *Pourquoi-Pas*? in 1921 in the western English Channel.—F. Ehrmann: The discovery of the Silurian with graptolites and the Devonian with tentaculites at Beni-Afeur (south of Djidjelli, Algeria).—Ch. Gorceix: The distribution of temperature in Lake Bourget.—Pierre Nobécourt: The mechanism of the parasitic action of *Penicillium glaucum* and of *Mucor stolonifer*. Experiments on the artificial ripening of sterilised fruits by inoculation with the two moulds named above. The action appears to be due to a secretion of enzymes, and the action takes place only in acid media.—Joseph Bouget: Observations on the most favourable altitude for the coloration of flowers.—Jean Dufrenoy: Tumefaction and tuberisation (in plants).—W. Mestrézat, Pierre Girard, and V. Morax: The elective ionic permeability of the cellular elements. Experiments on the cornea of the dog and rabbit prove that the permeability of the cells to electrolytes is an ionic permeability and that it is elective.—M. Doyon: Comparison of the effects of the nucleic acids and of the antithrombine of peptone plasma on the coagulability of the blood circulating in the frog.—L. Panisset and J. Verge: Idiocynerasy and anaphylaxy.—Maurice Nicloux and Georges Welter: Does cyanic acid exist in the blood? Attempts to show the presence of cyanic acid in the blood and lymph gave negative results.—A. Weber: Influence on the development of the eggs of a batrachian of a substance extracted from the fertilisine of the eggs of a fish.—A. Lécailion: Variability of the species and the experimental creation of new races in the silk-worm of the mulberry tree.—R. de La Vaulx: The appearance of intersexual forms in a strain of *Daphnia magna*, and on the probable determinism of the phenomenon.—A. Vandiel: Geographical spanandria in a terrestrial isopod.—R. Hovasse: A Peridinin, an intracellular parasite of the Vellela.

## MELBOURNE

Royal Society of Victoria, April 8.—Mr. F. Wisewould, president, in the chair.—F. Chapman: New or little-known Victorian fossils in the National Museum. Pt. XXVI. Some Tertiary Mollusca. Four-

teen new species of Pelecypoda and Gasteropoda are described and the distribution and diagnoses of eight other forms are discussed. So far back as Oligocene and Miocene times there existed many species of Mollusca which are so closely related to living forms that they are evidently the direct ancestors of present molluscan types. Others have migrated from the Bassian area and are now found only as varietal offshoots in warmer Australian waters. Certain species dating back to the older Tertiary are now found living in lower latitudes of the Southern Ocean.—H. B. Williamson: An addition to the flora of Victoria. A new species of *Helichrysum*, *H. Galesii*, has been found growing on dry hillsides a few miles from Lorne by the Rev. A. C. F. Gates. The plant resembles a *Leptorrhynchus*, but approaches very closely to *Helichrysum podolepideum*, a Central Australian species. It is probably a connecting link between sections *Oxylepis* and *Chrysocephalum* of the genus.—J. Shirley and C. A. Lambert: *Coprosma Baueri*, End. The leaf pits were examined, but no acarids were found. The pits are of teratological interest only, as the plant no longer lives under xerophytic conditions.—G. H. Hardy: Notes on some Australian Asilidæ (Diptera) in the collection in the National Museum. A new species of *Neotamus* is described, and notes and new descriptions on the remaining fifty-four species and one subspecies in the collection are given.—A. J. Turner: Studies in Australian Lepidoptera. A number of species obtained on the Claudie River in the Cape York Peninsula, N. Queensland, in the National Park, Queensland, and in Tasmania are described. Revisions of orders previously described are given, together with descriptions of some new forms.

## SYDNEY

Royal Society of New South Wales, May 3.—Mr. E. C. Andrews, president, in the chair.—E. C. Andrews: Presidential Address. The coral-bearing limestones of the Cainozoic within the Pacific are of two types, namely, Tertiary and Pleistocene. The Tertiary consist of sediments deposited unconformably upon sinking surfaces of submarine erosion, whereas the Pleistocene, although deposited unconformably along the Cainozoic, have grown in clear water away from the influence of silt-laden streams. No signs of bedding occur in them, and they are amorphous, massive, and homogeneous. Cliffs one thousand feet in height exist, which reveal no sign of structure. To understand the origin of coral reefs, it must be remembered that the continents bordering the Pacific have grown mainly towards that ocean in the form of land waves or undulations commencing at the continental nuclei, such as South-Western Australia, the Canadian Shield, Brazil, and Siberia. Island groups such as Japan, New Zealand, Fiji, and Tonga represent extensions of earth waves of this type. These earth undulations have grown as oscillatory vibrations with a progressive but slow radial movement of the major wave axes. Each island group forms a compound earth wave. Generally, the western islands and the larger individual groups, such as New Caledonia and Fiji, have been stable during the later Pleistocene, whereas the eastern satellite islands and islets have moved up and down in vibratory undulations during the same period. The true coral reefs of the Pacific indicate the peculiar vibrations and undulations of movement in these relatively unstable masses of the island groups and also the growth of great barriers and fringing reefs, such as the Great Australian Barrier, on submerged areas of submarine erosion. Generally, Pleistocene coral reefs are amorphous and non-bedded, and have been formed on submerged surfaces of submarine erosion at various stages.



# NATURE

A WEEKLY ILLUSTRATED JOURNAL OF SCIENCE.

*"To the solid ground  
Of Nature trusts the mind which builds for aye."*—WORDSWORTH.

No. 2753, VOL. 110]

SATURDAY, AUGUST 5, 1922

[PRICE ONE SHILLING

Registered as a Newspaper at the General Post Office.]

[All Rights Reserved.]

## BALANCES & WEIGHTS



## SPECTROMETERS

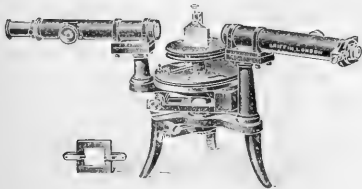

Particulars and Prices on application to—  
**JOHN J. GRIFFIN & SONS, LTD.**  
Kemble Street, Kingsway,  
London, W.C.2.

DO YOU KNOW  
THAT  
**VITREOSIL LABORATORY WARE**

is  
Incomparably Superior  
to any other similar Material?

IT IS  
Constant in Weight, Reliable,  
and Reasonable in Price.

Write for Pocket Edition of  
Price List.

**HEAT  
PROOF**



**ACID  
PROOF**

SOLE MANUFACTURERS

**THE THERMAL SYNDICATE, LTD.,**  
VITREOSIL WORKS—WALLSEND-ON-TYNE.  
LONDON DEPOT—28 VICTORIA ST., S.W.1.  
ALSO AT PARIS AND NEW YORK.

## BAROGRAPHS

Four rubber feet to the base  
—a self-adjusting pen arm—  
a supporting rod to the cover—  
these are some of the refinements  
on our Recording Barometers.  
Write for price list "B.3."

**NEGRETTI & ZAMBRA**  
38, HOLBORN VIADUCT, E.C.1.  
LONDON.

FACTORY : HALF-MOON  
WORKS, BARNBURY.

## NOTICE

The Index to Vol. 109 of NATURE will be issued with the number of the journal to be published on Saturday, August 12.

The price of the number will be 2s.  
ST. MARTIN'S STREET, LONDON, W.C.2

### UNIVERSITY OF LONDON, KING'S COLLEGE. FACULTY OF ENGINEERING.

Complete COURSES OF STUDY, extending over either three or four years, are arranged in

**CIVIL, MECHANICAL, AND ELECTRICAL ENGINEERING**  
for the Engineering Degrees of the University of London, and for the Diploma and Certificate of the College.

The four years' Course provides, in addition to the academic training, opportunity for practical training in "Works."

#### HEADS OF DEPARTMENTS.

Professor G. COOK, D.Sc., A.M.Inst.C.E., A.M.I.Mech.E., Mechanical Engineering.

Professor A. H. JAMESON, M.Sc., M.Inst.C.E., Civil Engineering.  
Professor E. WILSON, M.Inst.C.E., M.I.E.E. (Dean), Electrical Engineering.

Professor S. A. F. WHITE, M.A. } Mathematics.  
Professor G. B. JEFFERY, M.A., D.Sc. }  
Professor SAMUEL SMILES, O.B.E., D.Sc., F.I.C., F.R.S. } Chemistry.  
Professor A. J. ALLMAND, M.C., D.Sc., F.I.C. }  
Professor O. W. RICHARDSON, D.Sc., F.R.S., Physics.  
Professor W. T. GORDON, D.Sc., F.R.S.E., Geology.

Considerable extensions have been made in the Engineering Department. These include a large additional Drawing-Office, Lecture-Room, and Laboratory for Hydraulics and Strength of Materials in the Civil and Mechanical Departments; and Research Rooms, including Wireless Telegraphy, in the Electrical Engineering Department. Large additions have been made to the equipment of the Laboratories in the three Departments for purposes of Teaching and Research.

There is a College Hostel and a large Athletic ground.  
For full information apply to THE SECRETARY, King's College, Strand, W.C.2.

### BATTERSEA POLYTECHNIC.

Principal—\* ROBERT H. PICKARD, D.Sc., F.R.S.

University Courses, day and evening, under Recognised Teachers of the University of London are provided in Science, Engineering and Music.

CHEMISTRY.—\* J. KENYON, D.Sc., F.I.C.; \* J. L. WHITE, D.Sc.  
PHYSICS.—\* S. MARSH, B.Sc., Ph.D.; \* A. E. EVANS, B.Sc.; \* J. F. PHILLIPS, B.A., B.Sc.

MATHEMATICS.—\* F. M. SAXELBY, M.Sc., B.A.; \* F. W. HARVEY, B.Sc., M.A.; \* W. G. BICKLEY, M.Sc.

MECHANICAL AND CIVIL ENGINEERING.—\* W. E. M. CURNOCK, M.Sc., B.Eng.; \* J. B. SHAW, A.R.C.S., Wh.Ex.; \* H. M. EDMONDS, B.Sc.; \* V. C. DAVIES, B.Sc., A.M.I.Mech.E.

ELECTRICAL ENGINEERING.—\* A. T. DOVER, M.I.E.E., A.A.M.I.E.E.; \* H. C. MANN, A.M.I.E.E.

MUSIC.—\* H. D. WETTON, Mus. Doc., F.R.C.O.  
\* Denotes recognised teacher of University of London.

There are also—

Day Technical College in Engineering and Science. Day Training College of Domestic Science. Day Department of Hygiene and Physiology. Day School of Art and Crafts.

Evening Courses in Engineering, Chemistry, Physics, Mathematics, Bacteriology, Chemical Engineering, Hygiene and Physiology, Art, Matriculation Subjects, Domestic Economy, Music, Physical Training, Hostels for Women Students. Large playing fields at Merton.

### RESEARCH PRIZE OF \$1000.

The ELLEN RICHARDS RESEARCH PRIZE is offered for award in the year 1923. Theses by women based on independent laboratory research are eligible for competition and must reach the Committee before February 25, 1922. For circulars of information and application blank, apply to Dr. LILIAN WELSH, Goucher College, Baltimore, Maryland.

## NATIONAL UNION OF SCIENTIFIC WORKERS.

25 VICTORIA STREET, WESTMINSTER, S.W.1.

The main object of the Union is to secure in the interests of national efficiency that all scientific workers are given the fullest opportunity of working up to the hilt of their capacity in the service of the community.

There are now eighteen branches of the Union. They include those formed by:

- (i.) University Scientific Staffs and Research Workers and Scientific Staffs in other teaching institutions;
- (ii.) Government Scientific and Technical Staffs;
- (iii.) Scientific workers in Industry.

The General Secretary of the Union will be pleased to arrange for members of the Executive to address meetings of industrial, Government departmental, or university scientific workers, on the work of the Union.

A list of members and the Annual Report for the year 1920-21 will be sent on application to

THE GENERAL SECRETARY,

at the above address.

### ROYAL SCHOOL OF MINES FRECHEVILLE RESEARCH FELLOWSHIPS.

The Imperial College of Science and Technology, South Kensington, London, S.W.7, with which the Royal School of Mines is incorporated, is offering two RESEARCH FELLOWSHIPS of £300 a year each, tenable for one year and possibly renewable for a second year, to aid in carrying out any investigation or research connected with Mining, Mining Geology, Metallurgy, or the Technology of Oil, which in the opinion of the Selection Committee is of sufficient use or promise.

Applicants, who may be Associates of the Royal School of Mines or others, and preferably men with some practical experience, should apply in writing to the SECRETARY OF THE COLLEGE (from whom further particulars may be obtained) before September 1, 1922, giving the nature of the proposed investigation, qualifications for the work, and references.

It is anticipated that the Committee will make the awards by the end of November, so that the Fellowships and work may begin on January 1, 1923. Holders will be expected to devote their whole time to the work, which may be conducted at the Imperial College or in special circumstances elsewhere at the direction of the Committee.

### APPOINTMENTS BOARD

OF THE

### IMPERIAL COLLEGE OF SCIENCE AND TECHNOLOGY,

SOUTH KENSINGTON, S.W.7.

EMPLOYERS requiring men who have received a thorough training in Science and Technology, and who are Diplomates or Associates of the Imperial College, or of one of its three constituent Colleges, are asked to make use of the services of the Board. No fees.

The Imperial College includes The Royal College of Science, The Royal School of Mines, and The City and Guilds (Engineering) College. The Associates of the Colleges receive thorough training in Science and Technology, including Aeronautics, Applied Optics and Optical Engineering, Biology, Chemical Technology, Chemistry (all branches), Engineering (all branches, including Metallurgy, Mining, Mining Geology and Oil Technology), Geology, Mathematics and Mechanics, and Physics.

### THE INSTITUTE OF PHYSICS.

#### APPOINTMENTS REGISTER AND REGISTER OF CONSULTING PHYSICISTS.

The Appointments Register Committee is prepared to recommend to Public Departments, Universities and Colleges, Directors of Research, Manufacturers and others desirous of employing or consulting fully qualified physicists, suitable persons possessing special knowledge of any branch of physics.

By Order of the Board,

F. S. SPIERS, Secretary.

10 Essex Street, London, W.C.2.

### UNIVERSITY COLLEGE OF SOUTH WALES AND MONMOUTHSHIRE.

#### COLEG PRIFATHROFAOL DEHEUDIR CYMRU A MYNWY.

The Council of the College invites applications for the post of ASSISTANT-LECTURER AND DEMONSTRATOR IN METALLURGY. Salary, £300 per annum. Further particulars may be obtained from the undersigned, by whom three copies of application with testimonials (which need not be printed), must be received on or before August 26, 1922.

University College,

D. J. A. BROWN, Registrar.

Cardiff, July 15, 1922.



SATURDAY, AUGUST 5, 1922

## CONTENTS.

	PAGE
General and Specific Sanitation . . . . .	169
The Vegetation of High Asia . . . . .	170
Alcohol as a Fuel. By J. S. S. B. . . . .	172
Chemistry and Life . . . . .	173
Aristotle in English. By A. E. T. . . . .	174
A Rock-Desert. By G. A. J. C. . . . .	175
Our Bookshelf . . . . .	175
<b>Letters to the Editor:—</b>	
The Mode of Feeding of the Jelly-fish, <i>Aurelia aurita</i> , on the Smaller Organisms of the Plankton. —Dr. J. H. Orton . . . . .	178
Roche's Limits for Satellites.—Prof. J. Joly, F.R.S. . . . .	179
Optical Definition and Resolving Power.—J. Evershed, F.R.S. . . . .	179
Interspecific Sterility.—Prof. R. Ruggles Gates . . . . .	179
The Influence of Science.—Rev. A. L. Cortie, S. J. . . . .	180
Surface Tension and Cell-Division.—H. Graham Cannon . . . . .	181
Electricity and Matter. (With diagram.) By Sir Ernest Rutherford, F.R.S. . . . .	182
The Royal Botanic Society's Gardens. (Illustrated.) . . . .	185
<b>Obituary:—</b>	
S. P. Smith. By H. D. S. . . . .	187
Current Topics and Events . . . . .	188
Our Astronomical Column . . . . .	189
Research Items . . . . .	190
The Norman Lockyer Observatory. (Illustrated.) . . . .	192
Pioneer Work in Submarine Cable Telegraphy? . . . . .	195
International Chemistry . . . . .	196
Radio Broadcasting in Great Britain . . . . .	197
University and Educational Intelligence . . . . .	198
Calendar of Industrial Pioneers . . . . .	199
Societies and Academies . . . . .	200
Official Publications Received . . . . .	200

Editorial and Publishing Offices:

MACMILLAN &amp; CO., LTD.,

ST. MARTIN'S STREET, LONDON, W.C.2.

Advertisements and business letters should be  
addressed to the Publishers.

Editorial communications to the Editor.

Telegraphic Address: PHUSIS, LONDON.  
Telephone Number: GERRARD 8830.

NO. 2753, VOL. 110]

## General and Specific Sanitation.

ALTHOUGH hookworm infection (anchylostomiasis) is so rare in this country as to be unknown except among miners, the principles governing its control give an illustration of the relationship between specific and general control over infection, which is not without value for British hygienists. For this reason a monograph recently issued by the Rockefeller Institute for Medical Research<sup>1</sup> is deserving of attention. Hookworm disease is chiefly a rural disease in Brazil as elsewhere, and is most prevalent where there is complete disregard of elementary sanitation, especially in warm climatic conditions, which favour the life of the hookworm embryo in the soil, and encourage workpeople to go barefooted.

Dr. Smillie's investigation shows that hookworm disease is most common in the ages between fifteen and forty. It may be correctly described as an industrial disease, as it occurs chiefly in unshod field-workers. This fact comes out more clearly when a distinction is drawn, as it should be, between hookworm infection and hookworm disease. The importance of this distinction is gradually becoming appreciated in public health. In diphtheria it forms an essential consideration; and rational measures cannot be devised for the prevention of tuberculosis, which have no regard for this distinction. In male children under ten years of age the average number of intestinal hookworms per person was 39, increasing to 169 between ten and twenty, and over 200 in men between twenty and forty years old. The injury to health occurs chiefly in the persons showing heavier incidence of intestinal worms.

The work of Looss and his successors proved that the chief mode of hookworm infection is through the skin, by its contact with faecally contaminated moist earth, the mouth being an incidental and altogether unimportant channel of infection. This important fact in natural history suggests the two chief methods of control of the disease, the provision of latrines and covering for the feet. The third line of action, that of treatment of infected persons, has relatively smaller importance; and in Dr. Smillie's judgment treatment may properly be limited to field-workers, and may be disregarded for persons under five and over fifty-five years of age. Hookworm disease being an industrial malady, the construction of latrines in the working fields as well as domestically is indispensable if the disease is to be controlled; and the difficulty of reform in this direction is seen in the statement that there are practically no latrines in rural Brazil. As regards the second method of control, it has been found that the use of a crude pair

<sup>1</sup> "Studies on Hookworm Infection in Brazil, 1918-20." Second paper by Dr. Wilson G. Smillie (Monographs of the Rockefeller Institute for Medical Research, No. 17, May 12, 1922).

of half shoes by farm-workers has reduced infection to less than one-tenth of the usual rate suffered by those who did not wear shoes.

Only a few outstanding points in this valuable report have been cited, but enough has been given to show that in hookworm disease we have a notable illustration of the close connexion between elementary sanitation and the prevention of disease. In England we associate this connexion chiefly with diarrhoea and enteric fever, and William Budd's researches will always furnish the classical illustration of the close relations between defective latrine accommodation and the spread of infection as soon as typhoid fever is introduced into a village. The association is probably wider than is usually suspected. The relation of excessive diarrhoea to the continuance of conservancy systems in English towns and villages has been repeatedly emphasised, and there is strong reason for assuming a similar association of these systems with excessive pneumonia in young children.

But the hookworm story emphasises even more the importance of exact knowledge of the infecting agent. The provision of shoes or even their compulsory wearing is a novelty in sanitary administration from a British point of view; but it appears to be the most urgent need where hookworm disease is endemic. So, likewise, the fact that hookworm disease is an occupational disease shows where preventive work is chiefly needed, while the distinction between incidental infection and actual disease points to the persons among whom administrative control must be chiefly attempted. These contentions are illustrated in the paper by the wasted effort displayed in such public health work as the "swat-the-fly" campaign, in which a vast amount of effort and much money are expended in fruitless endeavours to eliminate flies by wholly illogical methods.

### The Vegetation of High Asia.

*Southern Tibet: Discoveries in Former Times compared with my own Researches in 1906-1908.* By Sven Hedin. II. *A List of Flowering Plants from Inner Asia, collected by Dr. Sven Hedin, determined by various authors, and compiled by C. H. Ostenfeld and Ove Paulsen.* Pp. 25+100+8 plates. (Stockholm: Lithographic Institute of the General Staff of the Swedish Army, 1922.) 30 marks.

KNOWLEDGE of the vegetation of High Asia is now extensive. The climate, while leaving something to be desired in other respects, favours the preparation of botanical specimens, and travellers in the inclement uplands of Tibet and the Pamirs have supplied much material for herbarium use. Yet,

owing to circumstances beyond their control, this material compares unfavourably with that secured by explorers in temperate and tropical regions. As a result, our acquaintance with the flora of High Asia is still far from exhaustive.

Geographical reconnaissance involves the investigation of as much ground as an expedition can map, and is thus somewhat incompatible with an intensive study of the vegetation of a given area throughout a round of the seasons. Any combination of the two activities means either that geography must be content with fewer data, or that botany must rest satisfied with indifferent material. The best botanical results of geographical expeditions are obtained during halts made when plants are in active growth.

The traveller in temperate regions may arrange his halts. In the tropics, as in high latitudes and at great altitudes, halts usually depend on meteorological conditions. Those caused by heat or rain coincide with periods of vegetative activity; those due to cold and snow occur when plants are dormant. The arctic-alpine flowering season is, besides, so brief that when the explorer sets out he may find only leaf-specimens; ere his journey ends, he may collect only specimens of plants the seeds of which have fallen. He may, if fortunate, secure complete material of species general along his route but he must be prepared for the possibility that his specimens of local plants are not always identifiable.

The botanical interest in any collection of plants from High Asia is therefore intelligible. Underlying this interest is a hope that new material may resolve old doubts. That hope explains our attitude towards arctic and alpine collections as compared with those from temperate latitudes or moderate elevations. A difference of a few days in the dates on which particular arctic or alpine camping-grounds were visited may give assurance to identifications originally tentative. The value of any High Asia collection is thus enhanced if it comes from districts already carefully investigated.

The importance of a census of the flowering plants found by Dr. Sven Hedin in the course of his various journeys in Inner Asia during 1894-1907 will therefore be readily appreciated. This census, compiled by workers so careful and competent as Prof. C. H. Ostenfeld and Dr. O. Paulsen, affords concrete evidence of the effects upon botanical survey of the exigencies of geographical exploration at great heights, and exemplifies the disadvantages against which the traveller on lofty uplands must contend.

The praiseworthy pains the authors have taken to identify many incomplete specimens have been more than justified by their results. Notwithstanding their care, the compilers have felt debarred from suggesting

specific names in the case of eleven, or 4 per cent. of the 275 plants enumerated. If to these we add the cases in which specific determination remains more or less doubtful, we have a total of 27, or nearly 10 per cent. of the whole. The authors have laid those who may study this census under a lasting obligation by recording the precise condition of the material available and thereby indicating why, as well as where, doubt attaches to certain identifications.

The imperfection of much of Dr. Hedin's material has induced the authors to restrict themselves to a taxonomic enumeration of the plants actually found by that eminent traveller in East Turkestan, the Pamirs, and Tibet, and to regard their work as supplementary to that of Dr. Hemsley<sup>1</sup> and Madame Fedtschenko.<sup>2</sup> Other considerations may have weighed with workers who are recognised as authorities both on plant-distribution and plant-association, when deciding that phytogeographical or ecological discussion is not yet feasible.

The census shows that Dr. Hedin collected 57 distinct plants in East Turkestan, 72 in the Pamirs, and 185 in Tibet, but that two only of the plants enumerated were found by him in all three regions; only one not met with in Tibet was found both in East Turkestan and the Pamirs, and only eight not met with in the Pamirs are recorded both from East Turkestan and Tibet, while no fewer than 27 not met with in East Turkestan are recorded both from the Pamirs and Tibet.

These figures are not surprising when regard is had to the fact that all the Pamir plants were collected at elevations of 12,000-15,000 feet and all the Tibetan ones were found at elevations of 8500-17,000 feet, whereas 44 of the 57 plants reported from East Turkestan were met with at altitudes of only 2750-3500 feet. Conformity as regards elevation may account for the appreciable common element in the Pamir and the Tibet vegetations; disparity in this respect may explain the relative isolation of East Turkestan. That isolation may indeed be greater than the census suggests. All the East Turkestan plants reported from altitudes exceeding 3500 feet were found in one or other of three localities. The thirteen plants in question include one of the three recorded as common to East Turkestan and the Pamirs and seven of the ten recorded as common to East Turkestan and Tibet.

One of these three localities is Toghde-gol, 9100 feet, in southern Tsaidam. This locality is cited in the census for four plants. Only in the case of two of these is the place said to be in East Turkestan; under the

others it is said to be in Tibet. Another of the localities is Bash-kurgan, 8750 feet, south of Lop-nor, which is cited for five plants. In connexion with two of these the place is said to be in East Turkestan, under a third it is stated to be on the East Turkestan-Tibet frontier, and in connexion with the two remaining plants the locality is placed in Tibet. The third locality, Tatlik-bulak, 6500 feet, is mentioned in connexion with eight plants. Here we have no such formal inconsistency; on each occasion the place is attributed to East Turkestan. But this does not remove all doubt; Tatlik-bulak lies south-east of Lop-nor and therefore farther east than Bash-kurgan.

It is possible that this discrepancy of statement merely reflects a difference in point of view. In floristic studies it is often convenient to respect political boundaries; in phytogeographical ones it is always desirable to recognise natural frontiers. From an ethnic standpoint all three localities may belong to East Turkestan; the evidence of the plants themselves suggests that from a botanical standpoint all three belong to Tibet. However this may be, the census prepared by Prof. Ostenfeld and Dr. Paulsen appears to justify one general conclusion. While it is clear that East Turkestan can be properly included in the region our authors speak of as "Inner Asia," it must be excluded from the region for which Dr. Hemsley has employed the term "High Asia."

How deeply we are indebted to Dr. Paulsen for our acquaintance with the vegetation of the western Pamirs, the drainage of which is towards Ferghana and the Oxus, readers of NATURE are already aware. Regarding the plants of the eastern Pamirs, the streams of which flow towards Yarkand, we have hitherto known little beyond what was to be learned from a few specimens gathered by Sir F. E. Younghusband thirty years ago in the Pamir of Taghdumbash. All save one of the Pamir plants in Dr. Hedin's collections are reported from the eastern half of the region; the evidence they afford is thus of unusual importance.

Unfortunately, that evidence is still far from complete. From the Taghdumbash Pamir, which from its connexions to the south and the east should perhaps prove the most "critical" of these high valleys, we have again to be content with a few specimens. Nearly 30 per cent. of Dr. Hedin's Pamir plants are from the Karakul Pamir, probably the least critical of the eastern valleys. More than 40 per cent. were gathered on the slopes of Mustagh-ata, highest of the Pamir peaks, but in this case it is not clear that all the Mustagh-ata plants were collected in one Pamir. Until the vegetation of these various eastern Pamirs has been investigated as exhaustively as that of the Little Pamir was by Lt.-Col. Alcock during the Pamir

<sup>1</sup> The Flora of Tibet or High Asia: W. B. Hemsley, assisted by H. H. W. Pearson (Jour. Linn. Soc., Bot. vol. xxv, pp. 124-265, 1920).

<sup>2</sup> Flore du Pamir: Olga Fedtschenko (Act. Hort. Petrop., vol. xxi, pp. 233-471, 1903; *ibid.* vol. xxiv, pp. 123-154, 1904; and pp. 313-355, 1905; *ibid.* vol. xxviii, pp. 97-126, 1907; and pp. 455-514, 1909).

Boundary Commission and as that of the Alichur Pamir was by Dr. Paulsen during the second Danish Pamir Expedition, the last word on the vegetation of this region as a whole must be left unsaid. The numbers of plants found by Dr. Hedin in all the eastern valleys visited by him falls short of the number which Lt.-Col. Alcock has taught us may be found in a single western one.

The evidence supplied by Dr. Hedin, imperfect though it be, does, however, sustain the general conclusion, based on our acquaintance with the vegetation of the western Pamirs, that while many plants are common to all, some are peculiar to each.<sup>3</sup> Another general conclusion to which the material obtained by Dr. Hedin appears to point is that it may prove more convenient and natural to employ the term "High Asia," restricted by Dr. Hemsley to Tibet, in an extended sense which will include also the "Pamirs."

Tibet is by far the largest of the three regions visited by Dr. Hedin; he collected there twice as many plants as he found in the Pamirs, and three times as many as he gathered in East Turkestan. The plants from Tibet which the authors have been compelled to describe as new are five times as numerous as the new species reported from both of the other regions. The authors of this census are therefore fully justified in remarking that its main interest lies in the Tibetan plants therein discussed. These facts notwithstanding, it is more impossible to deduce conclusions regarding the vegetation of Tibet from the evidence here supplied than it is to do so in the case of East Turkestan or of the Pamirs. The phytogeographical indications are sometimes as inconsistent as in the case of East Turkestan and are, if possible, more inexplicable than they are as regards that region. Localities are at times placed in Inner Tibet with no indication of latitude or longitude, and therefore with only imperfect clues as to their precise situation. When more precise indications are supplied, Inner Tibet is now given as synonymous with Northern, and as synonymous with Eastern Tibet. Certain localities are said in one case to be in North Tibet, in another to be in East Tibet. The list itself forms part of the sixth volume of a work entitled "Southern Tibet," yet it does not include any plant said to have been collected in South Tibet.

Perhaps the most interesting individual species in the list is one which Prof. Ostenfeld has proposed to treat as the type of a new genus, *Hedinia*. Though thus characterised, this plant, as it happens, is not a new discovery. It is one that so long ago as 1852 was referred by Dr. T. Thomson to the Cruciferous genus *Hutchinsia*, with the characters of which it conforms so indifferently that in 1861 it was transferred by Sir

J. D. Hooker to the genus *Capsella* as admittedly a very aberrant member. In 1904 Mr. W. Lipsky was so impressed by the unsatisfactory character of both these suggestions that he transferred the plant to the genus *Smelowskia*. With this particular genus, however, the plant has less natural affinity than it has with either *Capsella* or *Hutchinsia*. The treatment now accorded the plant by Prof. Ostenfeld is certainly more convenient than any hitherto proposed. It is to be hoped that it may also prove to be more natural and that it may provide a lasting memorial to the explorer whose name it is intended to perpetuate.

### Alcohol as a Fuel.

*Power Alcohol: Its Production and Utilisation.* By G. W. Monier-Williams. Pp. xii + 323. (London: Henry Frowde and Hodder and Stoughton, 1922.) 21s. net.

THE enormous increase in the number of engines using motor spirit throughout the civilised world, and the demand for other products of mineral oil, have forcibly directed attention to the great problem of the world's reserves of oil, and to alternative sources of fuels suitable for engines where a fuel of high vapour pressure is necessary. Dr. Monier-Williams deals in his opening chapter with this big problem—the motor fuel question—in a very comprehensive and clear manner. It is shown that while in 1913 the import of petroleum spirit into the United Kingdom was 101 million gallons, by 1920 the imports had reached 200 million gallons. In the United States (where it is said that there is one motor car to every eight of the population) the motor spirit consumption rose from 1200 million gallons in 1914 to 2680 million gallons in 1918.

It is clear that this modern development of locomotion, together with the requirements for aviation, will make further and further demands upon Nature's not inexhaustible reserves of suitable fuel. Although much has been accomplished in rendering a greater proportion of the crude oil available as fuel, by widening the distillation range, by "cracking" heavier fractions, and by taking out the more easily condensable portions of natural gas ("casing head gasoline"), the world is undoubtedly faced with the big problem of Nature's reserves of oil and the possibility of alternative supplies of liquids of sufficiently high vapour pressure to supplement, or in the long run largely to replace, the motor spirit derived from crude petroleum. Dr. Monier-Williams says "a complete solution of the motor fuel problem can only be found in the opening up of extensive, and as yet unproved, new areas of supply, together with the introduction of fuels derived from other sources than petroleum."

<sup>3</sup> NATURE, vol. cvii, p. 270 (April 22, 1921).

Allowing the exclusion of a liquid fuel produced by inorganic agency, he considers that "contemporary vegetation constitutes the only alternative to bituminous mineral deposits as a source of motor spirit, and it would seem that it must eventually supply (as alcohol) a large proportion of the world's requirements." To-day it is a question of the comparative cost of alcohol and petroleum spirit, and alcohol is at a serious disadvantage. In concluding his first chapter Dr. Monier-Williams cogently observes that "the balance of evidence certainly favours the view that before many years have elapsed the supply of petrol will be permanently unequal to the demand, and that power alcohol, considered from the standpoint of a supplementary and not necessarily competitive fuel, has an undoubted future before it."

The many problems associated with the economic production of fuel alcohol have received a great deal of attention, and the author has given a most complete account of the chemical and economic questions involved. In his later chapters he gives very full information on the results which have been obtained in practice with alcohol, and fuel mixtures containing it, and particular mention should be made of the excellent chapter on the chemical and physical properties of alcohol from the motor fuel standpoint. Here are included the important results which have recently been obtained by Ricardo, Tizard and Pye, and Ormandy.

One of the outstanding problems in connexion with fuel alcohol must be the bearing of excise regulations on its production, and the associated question of denaturing. When duty-free denatured alcohol was legalised in 1855 the duty was only 12s. per bulk gallon; to-day it is 6l. 3s. 3d. per gallon of 95 per cent. alcohol. To protect the revenue many onerous conditions have to be applied to production, and these necessarily are reflected in the costs, but some relaxation has already been sanctioned since 1921. It is now possible to import power alcohol as bulk cargo at certain ports, denature it in bond with at least 25 per cent. of petrol, benzol, or other approved substance, and to distribute the spirit without further restriction for power purposes alone. Dr. Monier-Williams deals very fully with these questions of excise supervision and denaturation, but concludes, after summarising the ideal requirements of a denaturant, that no substance has yet been found which fulfils satisfactorily all these conditions.

Whether "Power Alcohol" is considered from the point of view of the chemist, the engineer, or the general reader, it gives a complete and well-balanced consideration to all the problems associated with the production and utilisation. Sooner or later alcohol

seems bound to play no small part in our means of transport, but above all it is necessary to-day to maintain a proper sense of proportion, and this Dr. Monier-Williams may justly claim to have preserved. Enthusiastic advocates of a new development so often fail to recognise economic limitations.

J. S. S. B.

### Chemistry and Life.

*La Chimie et la Vie.* By Georges Bohn and Dr. Anna Drzewina. (Bibliothèque de Philosophie scientifique.) Pp. 275. (Paris: Ernest Flammarion, 1920.) Price 7.50 frs. net.

**B**YOND a short chapter with general statements concerning colloids, nucleoproteids and lipoids, and a chapter insisting upon the specificity of the chemistry of living animals and plants, chemistry plays no more part in the arguments of the authors of "La Chimie et la Vie" than many other sciences. The authors do not deal with pure chemistry, but with chemical physics—the object of which is to determine the influence exerted by physical conditions such as pressure, temperature and concentration of solutions on the progress or change of direction of chemical reactions. They object to the tendency to localise the various properties of plants and animals to particular chemical substances, and suggest that ferments, hormones, antibodies, etc., may not be specific substances so numerous and varied as the effects they produce; but they may be, on the contrary, various methods of activity of a limited number of substances resulting for the most part from the disintegration of living matter.

The main thesis of the book shows how insolubly bound up with one another are all the various branches of biological science. Discussion centres around recent work from practically every branch—chemistry, physical chemistry, zoology, botany, physiology, psychology, general biology, cytology, embryology, medicine, serology. The authors show how fruitful has been the introduction of chemistry to the study of phenomena of life and to what degree chemical physics has restored interest in and revived problems of biology. Some of their own work is recorded briefly. They describe how a double Hydra can be produced from a single Hydra by temporarily depriving the organism of oxygen, and how the symmetry of the Stauridium is altered by a simple change of environment.

The authors consider that the law of van't Hoff and Arrhenius may be applied to vital actions—development of the egg, reproduction, respiration, rhythm of the heart, and growth—and that the "law of reciprocal phenomena" holds for sleep, secretion, movement

and growth. They also attempt to establish a parallelism between form and movement, considering that the same factors acting through the same mechanisms are concerned with both. In the origin of form and in the origin of movement, physics and geometry are working in unison with chemistry.

Immunity, Abderhalden's "ferments of defence," anaphylaxis, agglutinins, hæmolysins, precipitins, the secretions of the interstitial glands of the reproductive organs, and hormones in general receive attention. Interesting experiments of tropisms, of fertilisation by chemical means, of experimental parthenogenesis, and of plant grafting, extend the scope of the book. The authors consider that the substances which kill are at the same time the substances which give life; thus, a tumour is submitted to the same physico-chemical determination as a developing organ.

The attempt to co-ordinate in a readable and instructive form the recent discoveries of biological interest is certainly successful, and the book is inexpensively though well arranged.

### Aristotle in English.

*The Works of Aristotle translated into English. De Cælo*, by J. L. Stocks; *De Generatione et Corruptione*, by Harold H. Joachim. (Oxford: Clarendon Press, 1922.) 10s. net.

THE great Oxford version of Aristotle could scarcely have begun to deal with that philosopher's physics and cosmology at a more opportune time than the present. It is only a year or two since Prof. Whitehead, speaking with all the authority that belongs to his utterances on such a subject, warned us that the first explicit beginnings of the "bifurcation" which has infected nearly all subsequent philosophising about Nature and natural science, are explicit in Aristotle, and that the duty of the *Naturphilosoph* of the present day is to put himself back at the Pythagorean standpoint represented by Plato's "Timæus" and study the "passage" of nature with a mind freed from the prejudices begotten of a substance-attribute metaphysics.

This weighty modern endorsement of Bacon's old complaint that Aristotle corrupted natural science at its sources by his "dialectic," must have set many who know little Greek wishing to have the means of knowing more accurately than can be known from modern summaries exactly what the Aristotelian interpretation of Nature was. The translation of the "De Cælo" by Mr. J. L. Stocks and of the "De Generatione" by Prof. Joachim comes very opportunely to meet the need, so far as Aristotle's astronomical and physical doctrines are concerned. It is to be hoped that we

shall not have to wait much longer for the versions of the "Physics," the treatise which expounds the Aristotelian mechanics of the universe, and the "Meteorologica," which deals with the "sublunary" department of cosmology.

The University of Oxford may be highly complimented on producing an English version of the two historically very important works before us, which may be taken by all but specialist scholars as equivalent to the original text. In constituting the actual Greek text, both translators have done excellent work in removing a large number of the singularly infelicitous alterations made by Prantl, the editor of the Teubner editions. Mr. Stocks has given a very generous amount of annotation to the explanation of his divergencies from Prantl; Prof. Joachim, having recently published his own recension of the "De Generatione," naturally makes his version avowedly from that text, and thus escapes the necessity of critical notes. It is perhaps a pity, in view of the appeal his version should make to many who are scarcely likely to possess his text and commentary, that he has not recorded quite briefly at least the more important of his differences from one of the standard texts, e.g. Bekker's. Of course it is inevitable that the fuller and more argumentative annotations of Mr. Stocks should at times require him to take sides on disputable points of reading or exegesis, and he himself would, no doubt, be the first to admit that appreciation of the value of his work does not imply agreement with all his decisions on such issues. To agree or disagree in detail would only be possible after a special minute study of Mr. Stocks's notes in conjunction with the Aristotelian text and the commentary of Simplicius.

We note that on one very important point the exact meaning of the original seems to have been misconceived. We believe it can be made clear that the kind of motion of the earth stated in "De Cælo," ii. 293 b 30 ff., to be spoken of by Plato in the "Timæus," is not "rolling" of any kind. If that had been meant, Aristotle would not have been so careful to say that the "Timæus" speaks of something different, "motion at the centre." It is clear also that axial rotation cannot be meant, for reasons into which space will not permit us to enter. The poetical word used in the "Timæus" and repeated by Aristotle (*ἄλλασθαι*) appears properly to describe "to-and-fro" motion, "oscillation," or "excursion" about a mean position. If we suppose that Aristotle knew, as he could scarcely help knowing, the correct interpretation of the Platonic phrase, we see at once why he is so careful to distinguish this movement of the earth "to and fro" about "the middle" from all theories of movement "round the middle." The point is important, because, in speaking



of movement "round the middle," Aristotle has just mentioned (293 a 28 ff.) an argument for it which we know, on the authority of Theophrastus, to be Platonic. It follows, therefore, that Plato is included among the "many others" who seem to agree with the Pythagoreans in denying that the earth is "at the middle," and that Aristotle was well aware that the theories Plato ascribes to Timaeus are not necessarily Plato's own theories, as has erroneously been assumed by almost all expositors of Platonism. A. E. T.

### A Rock-Desert.

*Ministry of Finance, Egypt. Petroleum Research.*

Bulletin No. 10. *Topography and Geology of Northern Sinai*. Part 6, Session 1919-1920. By F. W. Moon and H. Sadek. Pp. vii + 154 + 51 plates. (Cairo: Government Publications Office, 1921.) P.T. 50.

IT is no disparagement to the scientific observations recorded in this volume if we notice its handsome mode of production at the outset. In printing, illustration, and the inclusion of coloured sections, it will bear comparison with the work of any Geological Survey in the world. Two coloured maps on the scale of 1:250,000 are folded in a pocket at the end, and these are mounted on linen, a feature almost unique in official publication.

The researches that are placed in this permanent form before the public could not have been undertaken by private enterprise. Their object is to furnish a basis on which exploration may go forward in search of petroleum in Sinai, guided by the stratigraphy of a difficult and arid region. The oil-indications occur in Upper Cretaceous strata, mainly in the Cenomanian series, and any local concentration that may be found will depend on these beds as the primary sources of supply. Two places where the conditions seem favourable have been recommended to the Egyptian Government as sites for boring (p. 142). The clean exposures of rock-edges allow the geologist to read the structure of this desert country, as he can among the splendid folds of the Lange Bergen or in the high plateaus of Arizona. The features of a rock-desert are admirably pictured in photograph No. 12, where something is seen of the most notable structural feature of the region, the Cretaceous beds being strongly folded as they are traced downwards, while the conformable Eocene above them is almost undisturbed. The dome-structure sought for by oil-prospectors is thus present in the areas where beds older than the Santonian are exposed, but is scarcely to be traced in higher series. The authors, after a useful historical review (p. 37), advise the abandonment of the term Nubian Sandstone as indicating a stratigraphical horizon.

A thin band of potassium salt has been found under Gebel Sinn Bisher, a place where old workings, probably for rock-salt, may be traced. We may note the spelling Gebel, for Jebel, now adopted in Egyptian memoirs, which will commend itself equally to English-speaking folk. We congratulate Messrs. Moon and Sadek on carrying out this fine piece of mapping in a country where "life is, at its best, a very hard one," and where the Arab natives speak, quite happily, of their "homes" in caves cut in the mountain sides.

G. A. J. C.

### Our Bookshelf.

*La Géographie de l'Histoire: Géographie de la Paix et de la Guerre sur Terre et sur Mer.* Par Jean Brunhes et Camille Vallaux. Pp. vi + 716. (Paris: Félix Alcan, 1921.) 40 frs. net.

Two distinguished French geographers have collaborated in producing a volume on the relations of geography and history, which is really a treatise on political geography. Rather more than half the volume is concerned with the principles of the subject, and the remainder with their application to current political and social problems, arising out of the redistribution of territory and alterations in frontiers after the war.

Beginning with the thesis that man is the chief geographical agent, since he can more effectively modify the surface of the earth than the physical agencies at work, the authors consider the distribution of man. Regions of dense population may be either zones of passive concentration where conditions favour increase in numbers but do not demand any great degree of effort in order to find nutriment, and zones of active concentration where man, reacting against conditions not wholly favourable, triumphs by the exercise of effort. In the first category are regions of high temperature with considerable atmospheric humidity and abundant surface water, like the Chinese river valleys or the Nile delta. In the second category are oceanic borderlands and islands in temperate regions where conditions entail some struggle against sea and climate but are not unpropitious. In this category also are the areas where temperate forest has to be cleared and where coalfields are exploited.

From these "facts of fixation" the authors pass to "facts of movement" and discuss the influences behind migration and human movements. Some of the most important chapters in the book are those which deal with the growth and stability of states and the positions favourable to sites of capital cities. In struggle, though not necessarily war, the authors see one of the essentials for the healthy life of a state. Struggle means growth, but a state of political and social equilibrium means stagnation and decay. We have no space to do justice to this volume, and have indicated only a few of the ideas it contains. Every step in the authors' arguments is abundantly illustrated by concrete examples. The only drawback to the book is its lack of lucidity in places. The style at times is more ponderous than one would expect from French writers. There are black and white maps and full indices.

*Handbuch der Pflanzenanatomie.* Herausgegeben von Prof. K. Linsbauer. Allgemeiner Teil: Cytologie (Die Organe der Zelle). Band 1., Zelle und Cytoplasma. Von H. Lundegårdh. Pp. 192. Band 2., Allgemeine Pflanzenkaryologie. Von Prof. Dr. G. Tischler. Pp. 384. (Berlin: Gebrüder Borntraeger, 1921.) 2l. 5s.

THE volumes under notice are the first two in a series to be published under the general title "Handbuch der Pflanzenanatomie." The complete series as projected will number 15 or 20 volumes by various authors, under the general editorship of Prof. K. Linsbauer. It will include volumes on cytology, histology, galls, experimental anatomy, and a series on the "anatomy" of the various plant groups from Mycetozoa to flowering plants. Two volumes—both unfinished—have already been issued, the first, by Dr. H. Lundegårdh, dealing with the cell and cytoplasm; the second, by Prof. G. Tischler, giving a general account of the plant nucleus. The price quoted in English money for the two volumes, in paper covers, is unjustifiably high, and must mean a huge rate of profit for the publishers. The sale on these terms is not likely to be very wide.

The first volume begins with a history of plant anatomy and the cell theory, occupying 60 pages, and illustrated by figures from Hooke, Malpighi, N. Grew, and others. Then follows an account of cell structure and form, with numerous illustrations. The protoplasmic connexions between cells are considered at some length. Other topics considered are the arrangements of cells in tissues, and the physical and chemical organisation of the cell.

The second volume treats of the plant nucleus in considerable detail, beginning with the morphological and chemical organisation of the resting nucleus, and its relations to the cell as a whole. This part occupies 232 pages. The remainder of the volume, which is as yet incomplete, deals with nuclear division and its various forms in different plant groups. The numerous figures are taken from the cytological literature of the last thirty years.

*Thirty-fifth Annual Report of the Bureau of American Ethnology to the Secretary of the Smithsonian Institution. 1913-1914.* In 2 Parts. Part 2. Pp. viii+795-1481. (Washington: Government Printing Office, 1921.)

THIS volume forms an important supplement to that which preceded it, giving a collection of bardic chronicles and songs illustrating the beliefs and customs of the Kwakiutl, a fishing-tribe on the coast of Vancouver Island. It has been compiled by Mr. G. Hunt, a member of the tribe, and the text is given in the tribal dialect with an English translation. It is not easy reading, but the report in the preceding volume supplies an adequate commentary. It forms an impressive picture of life in the lower culture. We have traces of totemism in the shape of paintings of animals on the sides of the house door and posts erected with special ceremonies. Much of the ritual consists of orgiastic dances, performed by men and women in a state of nudity, wearing masks, their faces being painted with charcoal, on which swan-down is stuck, their heads and necks adorned with pieces of red cedar. It also assumes a more brutal form. In one account

we read: "The Rich-Woman carried in her arms a body, leading the Cannibal; and the Tamer went on the right-hand side of the Cannibal, and the One-Who-Presses-Down went on the left-hand side of the Cannibal, and each of the four eats part of the corpse—that is, the Cannibal and the Rich-Woman, and the Fire-Dancer and his Grizzly-Bear-of-The-Door." Scattered through the book are interesting accounts of the initiation of novices, the magical effect of names, magical songs sung to secure the capture of salmon, pre-nuptial incontinence, marriage by purchase and the levirate, burial in trees, magical transformation of men into animals, and much other matter of interest to anthropologists. It is well that these facts should have been recorded, as the tribe is rapidly coming under "civilised" influence. In one list of gifts we read of blankets, canoes, jewellery, forty sewing-machines, and twenty-five phonographs.

(1) *Lehrbuch der Elektrotechnik.* Von Dr. E. Blattner. Erster Teil. Vierte Auflage. Pp. ix+423. (Bern: K. J. Wyss Erben, 1922.) 20 fr.

(2) *Electricity.* By Sydney G. Starling. (Science in the Service of Man.) Pp. viii+245. (London: Longmans, Green and Co., 1922.) 10s. 6d. net.

(3) "*Lektrik*" *Lighting Connections.* With Introductory and Explanatory Notes by Gus. C. Lundberg and the late W. P. Maycock. Seventh Edition (Thoroughly Revised). Pp. 156. (London: A. P. Lundberg and Sons, 1921.) 1s. net.

(1) WE welcome the fourth edition of the first volume of Dr. Blattner's text-book. The principles of electrical engineering are very clearly stated and as the international symbols and nomenclature are adopted it can be readily understood even by a student whose knowledge of German is limited.

(2) Mr. Starling has written an interesting popular work on electricity. The subjects of the various chapters are well chosen, theory and practice being evenly balanced. The epoch-making discoveries of recent years in radio-telegraphy and in the theory of the atom are included.

(3) The third of the works under notice is a useful little book on electric wiring. It shows various ways of wiring electric lamps so that they can be controlled from several different places and also how the light they give can be varied. The special switches used for these purposes are described.

*Early British Trackways, Moats, Mounds, Camps, and Sites.* A Lecture given to the Woolhope Naturalists' Field Club, at Hereford, September 1921. By Alfred Watkins. Pp. 41+20 plates. (Hereford: The Watkins Meter Co; London: Simpkin, Marshall and Co., Ltd., 1922.) 4s. 6d. net.

IN this little book the author attempts to show that during a long period, going back at least to neolithic times, all trackways were in straight lines marked out by experts on a sighting system. Such sighting lines went from mountain peak to mountain peak with secondary sighting points on the lower ground. It is fairly obvious that long distance roads in primitive times would tend to lie in a more or less straight line between prominent peaks. This scarcely needs veri-

fiction, and Mr. Watkins' case must rest mainly on his intermediate points. These he finds in mounds, moats, tumps, churches (occupying the site of an earlier mark), stones, trees, and camps, holy wells, and the like. Place-names are also called in to support his argument. Without entering into a detailed examination of his evidence, which the reader may do with the aid of an ordnance map, it may be said generally that in some cases the so-called sighting marks were the objective of the road as in the case of a holy well or a ford, and that others, such as a burial mound or an encampment, owed their position to the previous existence of a road.

*Poverty and its Vicious Circles.* By Dr. Jamieson B. Hurry. Second and Enlarged Edition. Pp. xvi+411. (London: J. and A. Churchill, 1921.) Price 15s. net.

THE first edition of this detailed study of poverty was published before the war. In this second and enlarged edition the general plan of the work remains unaltered, but the author has revised and extended the original chapters and has written several new ones. Further, he has viewed his subject more from the international standpoint. His "vicious circles" are the various elements entering into the causation and perpetuation of poverty which aggravate or intensify the causes out of which they grew by lowering the standard of life and efficiency. Dr. Hurry describes in detail the effect of such factors as defective housing, defective feeding, defective clothing, defective education, defective credit, unemployment, insecurity, and the like. Each is considered separately, it being a part of the author's theory that each factor must be diagnosed and attacked in isolation; but the interaction of the circles one with another is both recognised and considered. The last portion of the book deals with remedial measures and gives a useful historical survey of poor relief under the State and by local authorities, and of the scope and objects of a number of private or semi-public voluntary organisations.

*Plant Materials of Decorative Gardening: The Woody Plants.* By Prof. Wm. Trelease. Second Edition, Revised. Pp. xliii+177. (Urbana, Ill.: The Author, University of Illinois, 1921.) 1 dollar.

By the help of this handy little volume a careful observer, who will make himself acquainted with the technical terms as explained in the glossary at the end of the book, may learn the name of any hardy tree, shrub, or woody climber that he is likely to find cultivated in the eastern United States—apart from the extreme south—or in northern Europe, except on the more pretentious estates, or in nurseries or botanical establishments. It accounts for 1150 distinct kinds, representing 247 genera and 782 species. For a few hopelessly complicated genera, such as haws, cotoneasters, and roses, only the most easily recognised species have been admitted. By means of a dichotomous key, divided into four sections—trees, bushes, undershrubs or bog or rocky plants, and woody climbers or scramblers—the name of the genus may be determined. The greater part of the book is occupied by a systematic description of the genera under their families, and under each genus is given a key to the species.

*Common Plants.* By Dr. M. Skene. (Common Things Series.) Pp. 271+26 plates. (London: Andrew Melrose, n.d.) 6s. net.

DR. MACGREGOR SKENE has produced a very readable series of essays, written in thirty-three chapters around different common plants, which are made the texts for a popular presentation of many of the problems and achievements of the modern study of plants. In the opening sections the themes of plant nutrition and the world's food supply are grouped around the wheat plant. Other chapters treat, for the popular reader, the various groups of plants, while still others are concerned with the rise of a land flora and various problems of the inter-relations of plants and animals, water supply, reproduction, and the relations of plants to man. The paper is unfortunately of poor quality, but the essays are excellently informed and attractively written, with lucid style and a human point of view.

*Scientific Management in the Home: Household Engineering.* By Mrs. Christine Frederick. (Efficiency Books.) Pp. 527. (London: George Routledge and Sons, Ltd., 1920.) Price 12s. 6d. net.

THERE is no place where the application of science is more desirable than in the home, and none where it is more commonly neglected. Mrs. Frederick, whose work is already known in this country through her connexion with *The Ladies' Home Journal*, here presents the story of her success in managing her own home. Science is to be found pleasantly blended with common sense in the pages of this book, which is to be recommended to the notice of private individuals as well as to those who are concerned with the teaching of domestic economy.

*Précis de physiologie végétale.* Par Prof. L. Maquenne. (Collection Payot.) Pp. 175. (Paris: Payot et Cie, 1922.) 4 frs.

THE author of this little book is a professor at the Museum d'Histoire naturelle in Paris, and here reproduces in simple, lucid, and attractive form the substance of a course of lectures given at the Museum for more than twenty years. The subjects briefly treated include osmosis, colloids, germination, growth, assimilation, respiration, etc. The definition of such terms as osmosis and colloid are not above criticism, but any one with no previous knowledge of the subject should find it an attractive and, on the whole, an accurate presentation of the general features of plant physiology.

*Dictionary of Botanical Equivalents: French-English, German-English.* By Dr. E. Artschwager and E. M. Smiley. Pp. 137. (Baltimore, Md.: Williams and Wilkins Co., 1921.) n.p.

THIS little dictionary of botanical terms should prove useful, especially for students. It is nearly all German, only 15 pages being devoted to the French-English portion. The pages are interleaved, so that additional terms can be entered at any time. The explanations given are not always happily chosen or accurate. Thus *zeitlicher Dimorphismus* is rendered "polymorphy."

## Letters to the Editor.

[The Editor does not hold himself responsible for opinions expressed by his correspondents. Neither can he undertake to return, or to correspond with the writers of, rejected manuscripts intended for this or any other part of NATURE. No notice is taken of anonymous communications.]

**The Mode of Feeding of the Jelly-fish, *Aurelia aurita*, on the Smaller Organisms in the Plankton.**

WHILE engaged in investigations (carried out with the aid of a Government grant) on the oyster beds in the River Blackwater, a jelly-fish (about 8 cms. in diameter) kept as a pet was given large numbers of oyster larvæ to see what it would do with them. From the fate of the oyster larvæ it was at once seen that the adult jelly-fish, *Aurelia aurita*, feeds definitely and—normally—automatically on smaller plankton organisms in a manner resembling that in which bivalves, some worms, and other animals feed on plankton. On adding the oyster larvæ to the jar in which the jelly-fish was living, it was observed that the larvæ were quickly formed up on the ex-umbrella surface of the jelly-fish in lines embedded in mucus and were also swept on to and retained in quantity on the oral arms. This immediately raised suspicion, and the jelly-fish was thereupon fed at intervals and carefully observed.<sup>1</sup> It was found that small plankton organisms of about the size of oyster larvæ were collected from the ex-umbrella surface of the jelly-fish and carried, mainly by ciliary action, towards the rim of the umbrella. The rhythmic waves of contraction of the bell or umbrella assist in carrying the strings of collected plankton-food to the edge of the umbrella, whence they are transferred—by a process not yet fully worked out—either to the oral arms or to the under surface of the rim of the umbrella. At the rim of the umbrella in this jelly-fish there is narrow curtain fringe cut normally into 8 segments so that one portion of the fringe lies between two of the marginal sense-organs (tentaculocysts). The fringe therefore resembles that often seen at the rim of a parasol except that it consists normally of 8 segments. The tentacles arise from the edge of the umbrella at the base of and outside this fringe.

It has thus been seen that by some means—partly by ciliary action and partly by contraction of the bell—a portion or all of the plankton collected on the ex-umbrella surface of the jelly-fish is transferred to the inner or outer sides of these umbrella fringes. Food-particles consisting of the smaller plankton organisms are, however, also collected on the inner surface of the umbrella and apparently also on the bases of the rim tentacles and transported in mucus by ciliary action to the inner side of the fringe at the edge of the umbrella. Plankton is therefore collected by both ex- and sub-umbrella surfaces and probably also on the bases of the rim tentacles and transported thence to the rim fringe. When the plankton reaches the rim fringe it is carried by ciliary action along the base to the middle of each segment of the rim fringe. Thus when an *Aurelia* has been feeding there are normally 8 blobs of food collected in the middle portions of the 8 rim fringes, which lie exactly opposite the straight adradial canals. It is curious that the point at which the blobs of food are constantly collected is not specially differentiated in any way unless it be by the development of an extra pucker in the rim fringe, which permits the accommodation

of the food-mass. As and when the blobs of food are collected, it can be observed that the jelly-fish deliberately and apparently consciously licks them off by passing over each the separated lips of an oral arm. The cilia on the internal faces of the arm quickly take charge of the food-mass and pass it into the groove made by the infolding of the sides of the oral arm. From the groove in the oral arm the food can be seen to be carried towards the mouth proper and travel by its own channel into the appropriate gastric pouch to be digested. When an *Aurelia* is actually feeding, food can be seen to be passing into the gastric pouches by four main channels. Oyster larvæ dropped on to the central region of the arms near the mouth appeared to be greedily accepted, and within a few minutes had passed into the gastral pouches by ciliary action through one or other of the four main food-channels. There are, however, two subsidiary food-channels to each gastric pouch, so that on occasions three strings of food can be seen passing into one gastric pouch.

After noticing the way in which this jelly-fish feeds it was realised that the kind of plankton in the sea at a particular moment could be speedily found out by capturing individuals and extracting and examining the collected food-masses from what may now be called the food-pouches on the rim of the umbrella opposite the straight adradial canal. Fortunately it was a simple matter to catch specimens of *Aurelia* recently washed into the oyster pits at high tide. Examination of such food-masses taken direct from the *Aurelia* showed them to consist of the following planktonic organisms: gastropod larvæ, of *Crepidula* and others, oyster larvæ (black spat), copepods, various species including *Calanus* and Harpacticids, Eucaridid larvæ in fair quantity, larvæ of cirripedes and copepods, Cypris larvæ of balanoids, young polychætes, especially *Polydora*, a good number of rotifers, algal threads green and brown, in one case with a large colony of vorticellids attached, eggs of polychætes or rotifers, eggs and tadpoles of *Ciona* and other ascidians, nematode worms, tintinnoids, a number of diatoms of several species, and some sand grains. In one instance an *Aurelia* was liberated for a few minutes in an oyster pit, which contained what was practically a good natural culture of the diatom *Nitzschia*. On examining the food-masses extracted from the food-pouches of this particular jelly-fish a few minutes after immersion in the water, fairly large numbers of the diatoms were found embedded in the mucoid food-mass.

It is clear, therefore, that *Aurelia* feeds mainly on what is technically termed medium to coarse plankton, but that it also captures small quantities of the finer plankton. In addition it is well known that larger organisms are taken and eaten, but from the above description it would seem that in the normal habitat of this jelly-fish, plankton organisms of the smaller kind will constitute the main diet.

From the relatively slight morphological variations which occur in the group to which *Aurelia* belongs, it would seem highly probable that a similar but probably modified mode of feeding occurs throughout the group. In some members of the group it is well known that young fishes frequently take shelter under the umbrella and often inside the cavities of the jelly-fish with impunity, but hitherto it has been difficult even to guess at a reasonable explanation of the association of a jelly-fish with—that has often been considered legitimate prey—young fishes. The mode of feeding in *Aurelia*, however, suggests a possible explanation of this phenomenon if, as is very likely, other allied jelly-fishes feed in a similar way. The aggregation of plankton-food in masses provides an excellent opportunity for parasites, as

<sup>1</sup> Gemmill (Proc. Roy. Phys. Soc. Edin., vol. xx, part 5, 1921) records some interesting notes on food-capture and ciliation in the epiphyra of the jelly-fish, which are not, however, the same as in the adult, the structure of which is more complex.

is seen in the case of the pea-crab and various bivalve molluscs and ascidians, or Myzostoma and Antedon. Now many jelly-fishes are infested with amphipods such as Hyperia, and it is a reasonable deduction that these crustaceans may be feeding on the food material collected by the jelly-fish. Thus, if the young fishes which take shelter below the umbrella of a jelly-fish assist the jelly-fish by keeping down ecto-parasites such as Hyperia, then an intelligible explanation is offered of the association of young fishes with such an apparently voracious host as a large jelly-fish, for in return the jelly-fish in these circumstances would have less of its own food stolen.

J. H. ORTON.

Oyster Store, Packing Shed Island,  
West Mersea, July 2,  
and The Laboratory, Plymouth, July 14.

#### Roche's Limits for Satellites.

THE notice in NATURE (July 15, p. 89) respecting Dr. Fountain's work on Roche's limit for satellites brings to my recollection some estimates which I made many years ago with respect to the stability of satellites moving close to the surface of Mars (Trans. Roy. Dub. Soc., 1897, vol. vi.).

The question arose in connexion with a theory accounting for the "canals" as resulting from stresses set up in the surface rocks of Mars by the proximity of such satellites. The doubling of the canals came out nicely and the curvature of the canals as mapped by Lowell, Douglass, and Pickering was in agreement. But the doubt arose as to whether former satellites of sufficient magnitude could have preserved their stability when circulating around the planet with the requisite degree of approximation.

Assuming that the satellite possessed the cohesive strength of basalt and taking the case of Phobos supposed to be moving in an orbit but 23 miles from the planet's surface (*i.e.* with but five miles separating the surfaces of planet and satellite), I found that the satellite, even at this distance, would be stressed only to one-seventh of its breaking strength.

J. JULY.

Trinity College, Dublin, July 15.

#### Optical Definition and Resolving Power.

IN Mr. Mallock's letter on "Definition, Resolving Power and Accuracy," published in NATURE of May 27 (vol. 109, p. 678), reference is made to the measurement of star images on eclipse plates, from which one might infer that the evidence for the Einstein deflexion of light obtained in 1919 was of a very doubtful character.

I have had no experience in measuring star images; but there is little doubt that if the same order of accuracy can be obtained as is possible in measuring spectrum lines, the Einstein deflexion should be easily determinable with a focal length of 19 feet, provided that it can be disentangled satisfactorily from the scale correction.

In my method of measuring photographs of spectra the image of a line is not bisected by a thread, but a positive copy is superposed on the negative in the micrometer and the coincidence of the two images estimated. By this means the intervals to be measured are doubled, and an extraordinary degree of precision is attainable with practice, as is shown by the agreement between different measurers. I have often had occasion to repeat measures made by one of my assistants of the shifts of the solar lines with reference to the arc lines, and we rarely differ by an amount exceeding 0.001 mm. in the interval measured. This is the result of taking the means of six settings in

each line, and the probable error derived from the accordance of settings is usually about half a micron.

Probably star images cannot be measured so accurately as this by the ordinary method of bisection, but a skilled measurer should be able to determine the position of a star easily within 0.005 mm. or, on the scale of the eclipse plates, within 0".18.

J. EVERSHED.

Kodaikanal, June 24.

#### Interspecific Sterility.

DR. BATESON in his letter on interspecific sterility (NATURE, July 15, p. 76) seems to lay insufficient emphasis on certain facts. If one considers plant and animal species in general, it would appear that interspecific sterility is by no means so general as was formerly assumed to be the case. Among the *Enotheras*, in which great numbers of species crosses have been made, complete fertility, in the sense that large numbers of fertile offspring are produced, is the rule unless the forms differ in chromosome number. Even species of *Enothera* which come from widely separated regions and differ conspicuously in all their characters, including flower-size, are fertile in crosses. That a certain amount of gametic and zygotic sterility also frequently occurs is of course well known, and it is probably correctly interpreted in terms of lethal factors. But lethal factors are not peculiar to wild species, for numbers of them arise in the mutations of *Drosophila melanogaster*.

Among animals, interspecific sterility appears to be more widespread, but even here the Bovidae are, I believe, all interfertile. The contrasted condition of the Equidae, at least as regards the horse and the ass, is accounted for by the difference in their chromosome numbers. In the *Drosophilidae*, where interspecific sterility is extreme, there is a considerable range in chromosome form and number. The two species, *Drosophila melanogaster* and *D. simulans*, which are extremely alike and have similar chromosome groups yet produce sterile hybrids, might be cited as corresponding exactly to Dr. Bateson's conception of interspecific sterility. But it is an extreme case, and there are probably more numerous instances to cite on the other side.

Dr. Bateson refers to the case of *Enothera gigas* and agrees that tetraploids frequently do not breed freely with diploids. But he says that "the applicability of that example is exceedingly doubtful" because we "can scarcely regard an unresolved pair of twins, such as the tetraploid must be, as a specifically distinct organism." It is this statement in particular to which I should be inclined for several reasons to take exception. In the first place, in calling the tetraploid an "unresolved pair of twins" Dr. Bateson scarcely recognises the intimate character of the union involved. I formerly analysed (*Arch. f. Zellforsch.* vol. 3, pp. 525-552, 1909) the changes which have occurred in *E. gigas* in so far as this could be done by comparative cell measurements, and found that the cell units were not merely larger, owing to the doubling in the chromosome content of their nuclei, but that in various tissues they were altered in shape, the increase in one dimension having been much greater than in another. Moreover, the genetic behaviour of *E. gigas* indicates, as de Vries first contended, that some other change has taken place in the germplasm of this species, in addition to the doubling of the chromosomes.

I have only recently been convinced on this point by comparisons of *E. gigas* with the tetraploid forms obtained by Winkler (*Zeits. f. Botanik*, 8,

417-531, 1916) from his grafting experiments with the tomato. Here the tetraploid form apparently arises through the fusion of pairs of somatic nuclei where the cut surfaces of the cells are in contact. The forms obtained in this way appear to be merely tetraploid, stouter but without any alteration in the shape of leaves or other organs such as occurs in *E. gigas*. Winkler shows that these tetraploids have larger cells, nuclei and chloroplasts, but there are apparently no changes in cell shape except in the pollen grains, which have four pores instead of three just as in *E. gigas*. There seems no reason to alter my original interpretation of this change in the pollen grain as a direct result of the altered space relationships between the larger cell and its nucleus in the tetraploid forms.

It therefore appears probable that in some experimental tetraploid forms, such as Winkler's *Solanum*s and probably the Marchals' tetraploid mosses, all the changes are such as follow directly from the original doubling of the chromosomes, while in others such as *E. gigas* and certain wild tetraploid species, an additional change has taken place in the germplasm. One cannot yet, however, regard this as fully proven.

It might also be pointed out here that the wide occurrence and evolutionary significance of tetraploid species in nature has not yet been generally realised by biologists. In *Potentilla*, for example, a whole group of wild species is tetraploid as compared with others. Species with  $4X$  chromosomes are also known to occur in many other genera, such as *Lactuca*, *Crepis*, *Muscari*, *Acer*, etc. Such a doubling of the chromosome number must have occurred in connexion with the origin of many wild species and genera.

Tetraploidy undoubtedly forms a barrier to free crossing with diploid forms in any line of descent. I therefore see no reason why such forms as *E. gigas* arising in cultures should not be regarded as mutations significantly accompanied by partial inter-specific sterility. For both in cultures and in Nature the cross-breds with unbalanced chromosome groups tend to be eliminated, leaving the pure forms each to perpetuate itself.

R. RUGGLES GATES.

King's College, Strand, London.

### The Influence of Science.

In his letter to NATURE (July 15, p. 78) Sir George Greenhill does well in directing attention to the fact that the quarrel between Galileo and the Holy Office was largely a domestic quarrel between two opposing schools of thought. It is historically a fallacy, though a very common one, to suppose that the freedom of experimental inquiry was secured in consequence of the action of the Roman Curia in the case of Galileo. So long as scientific investigators confined themselves to their own legitimate subjects of study, and left doctrinal and Scriptural matters alone, freedom of experimental inquiry was never interfered with by ecclesiastical authority. Nicholas Copernicus was a devout Catholic priest, and his heliocentric doctrine was freely taught, even in ecclesiastical colleges, until Galileo interested himself as a champion of the system.

For Galileo, as all historians testify, was a truculent and hot-headed controversialist, who, in spite of the advice of his friends not to raise the question (I quote from his contemporary Guicciardini, the Tuscan ambassador), "demanded that the Pope and the Holy Office should declare the Copernican system to be founded on the Bible; he wrote memorial after memorial. Paul V., wearied with his importunities, decreed that the controversy should be

determined in a Congregation, and having sent for Cardinal Bellarmine, ordered him to bring it immediately before the Holy Office." Let me make use of an analogy from the practice of our own English Courts to elucidate the matter. The Court of King's Bench was originally constituted to judge cases pertaining to the King's peace. To widen its jurisdiction, all classes of injuries, even actions for breach of contract, had to be interpreted as acts of violence, even though perpetrated by otherwise peaceful citizens.

Similarly, the Holy Office had, by its procedure, to consider every case submitted to it, with reference to heresy and orthodoxy. Let us also bear in mind that Holy Scripture must ordinarily be interpreted literally, unless a rigid proof can be adduced to the contrary. What rigid proofs, in the then state of scientific knowledge, could Galileo allege in support of his contention that the Copernican system was founded on the Bible? Let us recall in passing that such eminent men of science as Tycho-Brahe and Bacon rejected the system, while Descartes would not admit the hypothesis as proved, and that the Cardinals of the Congregation, so far as proofs of Copernicanism were concerned, had perforce to rely upon the opinion of their scientific advisers. The only proofs that were brought forward were the analogy of Jupiter's satellites, the moon-like phases of Venus, and the simplicity with which the theory accounted for the observed motions of the planets. The other alleged proofs from the tides and the earth's magnetism were worthless.

On the other side was the apparent authority of the words of Scripture, the universal experience of mankind, which seemed to attest that the earth was immovable, while the sun, moon, and stars moved round it, and the Ptolemaic system which for centuries had explained in a satisfactory manner the apparent movements of the planets. In such circumstances what could the Congregation do but declare, according to the forms of the court, that the Copernican system was heretical, in the sense that it contravened the literal and obvious meaning of Scripture? According to the knowledge of that time, the Copernican system was "false and absurd philosophically, inasmuch as it expressly contradicts the doctrine of Holy Scripture." The proviso and restriction is noticeable.

What did Galileo do? Instead of teaching the Copernican theory as a scientific hypothesis, after a most generous reception in Rome in 1624 by his friend Pope Urban VIII., he returned to Florence, and in his famous Dialogue not only lampooned his benefactor, but was guilty of gross contempt of court. For such egregious contempt of court an English judge would rightly commit a man to prison. Galileo had as a penance to recite certain prayers, and was sent to a beautiful villa at Arcetri, where, free from the disturbing influences of controversy, he was at liberty to pursue his favourite studies.

As Whewell says in his "History of the Inductive Sciences," pp. 425-6, "The persecutors of Galileo are still held up to the scorn and aversion of mankind; although, as we have seen, they did not act until it seemed that their position compelled them to do so, and then proceeded with all the gentleness and moderation which were compatible with judicial forms." Or, to quote another non-Catholic, Prof. A. De Morgan (English Cyclopædia, "Motion of the Earth"), "We heartily wish all persecutions, Catholic and Protestant, had been as honest and as mild." Nor did the Roman Curia possess a monopoly in opposition to Copernicanism. Martin Luther went further, for he considered Copernicus to be an arrogant fool, who wrote in defiance of Scripture, while Melancthon declared

that such mischievous doctrines should be suppressed by the secular arm.

Finally, is it not time that this old bogey of the case of Galileo, as a proof that the Church was opposed to scientific research, should be decently buried? "The Papal power," wrote De Morgan (*loc. cit.*), "must on the whole have been moderately used in matters of philosophy, if we may judge by the great stress laid on this one case of Galileo." Cardinal Newman dubbed it rightly as "the one stock argument."

A. L. CORTIE, S.J.

Stonyhurst College Observatory, Lancs.

July 17.

### Surface Tension and Cell-Division.

In a recent paper on "Surface Tension and Cell-Division" (*Q.J.M.S.* 66, pp. 235-245), Mr. J. Gray maintains that "cell-division may be accounted for by the movement of the two asters away from each other," and that "there is no necessity to postulate regions of differential surface tension at the poles or equator of the cell."

These conclusions are drawn chiefly from the results of a series of experiments in which the effect of "acid" sea-water on the cleaving eggs of *Echinus miliaris* is interpreted in the light of the effect of increased hydrogen-ion concentration on an oil-water interface. Mr. Gray points out that there is undoubtedly a lipid or oily phase in the protoplasmic surface, but, if any value is to be placed on the analogy between the effect of acid on cleaving eggs and on an oil-water surface, one has to suppose that the lipid phase in the protoplasmic surface is a continuous phase, otherwise two different types of surface are being dealt with. This view, as pointed out by Bayliss (2nd Brit. Assoc. Rep. Colloids, 1918), would necessitate that the volume of the cell should not have any definite relation to the osmotic pressure of the external solution.

In these experiments it was shown that if the egg, in which a cleavage furrow had appeared, is placed in "acid" sea-water, the furrow disappears and, owing to the unknown force which elongates the egg, equilibrium is attained when the egg has the form of a cylinder with hemispherical ends. The shape of the dividing egg is stated to be dependent entirely on (a) the surface tension at the egg surface, and (b) the other force acting against the surface tension which produces elongation of the cell axis and is "associated in some way with the elongation of the astral figure." Now the pressure inside the fluid egg at any region due to surface tension can be determined from the curvature of the egg surface in that region. Since the egg is presumed to be in equilibrium at any stage during mitosis, any inequalities in pressure due to the surface tension and resulting from the varying curvature, must be counteracted by the second "elongating" force. In the case quoted above, in which the dividing egg is in equilibrium when its shape is that of a cylinder with hemispherical ends, it is easy to show that the pressure inside the hemispherical caps due to surface tension is exactly twice the pressure inside the cylindrical portion due to surface tension. Thus the elongating force, of which the astral figure is to some degree an expression, must produce a differential pressure on the inside of the egg surface, such that the pressure exerted over the middle cylindrical portion is uniform and equal to half the pressure produced over the hemispherical ends. If the view is accepted that the mitotic figure is in any way connected with the force that produces elongation and cleavage of the egg, I think the hypothesis that

this force is essentially a polar force must be adopted, and it is difficult to see how any polar force could produce such a distribution of forces as is necessitated to produce equilibrium in the fluid cylindrical egg described by Mr. Gray.

He further describes an experiment as due to Plateau, on a drop of oil placed between two metal rings "so as to form a complete cylinder" (of course, with spherical end surfaces), which, on moving the two rings apart, changed in form, when the distance between the rings became greater than  $\frac{3}{2}$  the diameter of the rings, in the same way as a dividing egg. The exact reference to this experiment is not given, but the experiment is very similar to one that Plateau carried out on the stability of a fluid catenoidal surface. According to Mr. Gray a cleaving egg can be divided into three parts: a middle cylindrical portion and two convex ends to this cylinder. The middle cylinder is taken to be analogous to the drop of oil in Plateau's experiment. It is obvious, however, that the whole of this experiment depends on the fact that the two rings, as they are being moved apart, exert a lateral thrust on the surface film of the drop. Is one, then, to believe that the force which causes the egg to elongate also exerts a lateral thrust in two parallel planes corresponding to the two rings? Actually, if there is sufficient oil between the two rings they may be moved apart to a distance equal to  $\pi$  times the diameter of the rings before the central cylindrical portion becomes unstable and divides, but this in no way resembles the form of any cleaving egg, so far as I am aware.

While I quite agree with Mr. Gray that the mitotic force counteracts the effects due to surface tension, it seems to me that one cannot account for the stability of his cylindrical stage on the supposition of uniform surface tension over the whole egg surface, without ascribing to that mitotic force properties that one would hesitate to ascribe to forces focussed round two definite centres. Unless the view that the forces which elongate the egg are correlated with the spatial relations of the two centrosomes is adopted, all the morphological evidence of the mechanism of cell-division is neglected.

In the introduction to his paper Mr. Gray says that theories postulating a higher or lower surface tension at the equator of a cleaving cell are of little value, as "there is no apparent means of determining how such a state of affairs could arise." In many cells it has been shown that the cytoplasmic inclusions are arranged around the centrosomes as foci, and further, that the distribution of these elements may be correlated with the apparent activity of the centrosomes. From this it may be inferred that there are substances in the egg which are repelled or attracted, either directly or indirectly, by the centrosomes. One of the first events in the cleavage of an *Echinus* egg is the appearance of two "active" centrosomes. These are approximately symmetrically placed in the egg and move apart from one another. Substances repelled by the centrosomes will tend to gather at the surface of the egg, but, as the centrosomes move apart, these bodies, once having reached the surface, will move towards that region of the egg surface in the plane in between the two centrosomes, which is termed the equator of the egg. If the presence of these substances in the surface film of the egg affects in any way the surface tension of the protoplasmic surface, here is a mechanism whereby there may arise a differential surface tension over the surface of the cleaving egg.

H. GRAHAM CANNON.

Imperial College of Science and Technology,

South Kensington, London, S.W.7.

July 14.

Electricity and Matter.<sup>1</sup>

By Sir ERNEST RUTHERFORD, F.R.S.

IT has been customary in the earlier Kelvin lectures to give an account of some phase of Kelvin's work. I could easily follow this custom by concentrating on the publications of Kelvin that deal with the proof of the atomic nature of matter and the dimensions of atoms and molecules, including the first suggestions of the mechanism of atomic constitution. This was a subject in which Kelvin was permanently interested. In his Royal Institution lecture of 1883, reprinted in "Popular Lectures and Addresses," vol. 1, he gives an illuminating account of the different lines of evidence that all converge to a cumulative proof that matter is coarse-grained or atomic in structure and set a definite minimum limit to the dimensions of the atom. His deduction of the diameter of the water molecule from the cooling effect observed when a water film is stretched, is one of the most notable of these examples. In his later papers he accepts Stoney's arguments in support of the atomic nature of electricity, and in a paper of curious title, "Æpinus Atomised,"<sup>2</sup> he restates the old theory of Æpinus of the nature and relation of positive and negative electricity in a more modern form, by assuming that the negative electricity in an atom is distributed in the form of definite units called "electrions"—or electrons, as we should now term them—held in equilibrium embedded in a sphere of uniform positive electrification. This was the first type of model atom put forward. A similar type of atom, developed and worked out in detail by Sir J. J. Thomson, played a notable part in giving a concrete view of atomic structure which was directly amenable to mathematical calculation. In some of his later papers, Kelvin devised types of atoms which, under certain disturbances, broke up with explosive violence, simulating in behaviour the atoms of radium. While keenly interested in such speculations, there remained the curious anomaly that he did not accept entirely the current explanation that radio-activity was a consequence of the successive disintegrations of atoms.

The discovery in 1897 of the individual existence of the negative electron of small mass, and the proof that it was a component of all the atoms of matter, was an event of extraordinary significance to science, not only for the light which it threw on the nature of electricity, but also for the promise it gave of methods of direct attack on the problem of the structure of the atom. This discovery of the electron, coupled with the recognition of the atomic nature of electricity, has created a veritable revolution in our ideas of atoms.

The first definite proof of the close relations that exist between electricity and matter we owe to the famous experiments of Faraday on the passage of electricity through electrolytes. It was clear that the simple numerical relations found by him between the electrochemical equivalents of the elements and their atomic weights could be simply interpreted by assuming that electricity was atomic in character and that the charges carried by the individual ions were integral multiples of a fundamental unit of charge. It is curious to note the long interval that elapsed

before the idea of the atomic nature of electricity was generally accepted by men of science—possibly because of the great difficulty of obtaining confirmatory evidence. The suggestion was mentioned by Maxwell and Helmholtz, although with reservation, but was revived with conviction by Johnstone Stoney, who suggested that the name "electron" should be applied to the fundamental unit of electricity and made a rough estimate of its magnitude. Actually, as we know, the term "electron" is now used to denote not the actual value of the unit of charge, but the free atom of negative electricity.

Following the discovery of the independent existence of the electron and the proof of the production of charged ions in gases by X-rays and other radiations, it was implicitly assumed by men of science that electricity must be atomic in nature, and all the experimental data were interpreted on this view. It was found by Townsend that the charge carried by the ions produced in gases and by the electron itself was numerically equal to that carried by the hydrogen ion in the electrolysis of water, which was taken as the fundamental unit. By the ingenious device of balancing the weight of a charged drop by the attraction of the electric field, Millikan was able to give a very direct and convincing proof of the correctness of this view and to determine the magnitude of the fundamental unit with great precision. Knowing the value of this constant, the electrochemical data give us immediately the mass of the atom of each of the elements. While no one now doubts the atomic nature both of matter and of electricity, it should be noted that the atomic nature of matter is in reality a consequence of the discrete nature of electricity, for all the evidence indicates that the atom itself is a purely electrical structure.

It was soon recognised that the negative electron of small mass was an actual disembodied atom of electricity, and that its apparent mass was electrical in origin. Sir J. J. Thomson had shown as early as 1881 that a charged body in motion behaved as if it had an additional electric mass due to its motion. The moving charge generates a magnetic field in the space surrounding it, resulting in an increase of energy of the moving system which is equivalent to the effect produced by an increase of the mass of the body. The experiments of Kaufmann and others on the swift electrons ejected from radium showed that the mass of the electron, while sensibly constant for slow fields, increased rapidly as the velocity of the electron approached that of light. This variation of mass was in good agreement with calculations based on the electrical theory. Later, Einstein from considerations of relativity showed that for any material particle, whether charged or not, the mass  $m$  must vary with speed according to the relation  $m/m_0 = (1 - \beta^2)^{-\frac{1}{2}}$ , where  $m_0$  is the mass for low speeds, and  $\beta$  is the ratio of the velocity of the particle to the velocity of light. Experimental results agree closely with this calculation.

Since there must always be electric mass associated with the movement of electric charges, it is natural

<sup>1</sup> From the thirteenth Kelvin lecture, delivered before the Institution of Electrical Engineers on May 18.

<sup>2</sup> *Philosophical Magazine*, March 1902.



to suppose that the mass of the electron is entirely electrical in origin, and no advantage is gained by supposing that any other type of mass exists. If the atom is a purely electrical structure, the mass of the atom itself must be due to the resultant of the electric mass of the charged particles which make up its structure. We shall see that only a small fraction of the mass of an atom can be ascribed to the negative electrons contained in it, but the main part is to be ascribed to the positively charged units of its structure. One of the main difficulties in our attack on the question of atomic constitution has lain in the uncertainty of the nature of positive electricity. Without entering upon the changes in point of view on this important question, it may suffice to say that the evidence as a whole supports the idea that the nucleus of the hydrogen atom, *i. e.* a positively charged atom of hydrogen, is the positive electron. No evidence has been obtained of the existence of a positively charged unit of mass less than that of the hydrogen nucleus, either in vacuum tubes or in the transformation of the radioactive atoms, where the processes occurring are very fundamental in character.

It might *a priori* have been anticipated that the positive electron should be the counterpart of the negative electron and have the same small mass. There is, however, not the slightest evidence of the existence of such a counterpart. On the views outlined, the positive and negative electrons both consist of the fundamental unit of charge, but the mass of the positive is about 1800 times that of the negative. This difference in the mass of the two electrons seems a fundamental fact of nature and, indeed, is essential for the existence of atoms as we know them. The unsymmetrical distribution of positive and negative electricity that is characteristic for all atoms is a consequence of this wide difference in the mass of the ultimate electrons which compose their structure. No explanation can be offered at the moment why such a difference should exist between positive and negative electricity.

Since it may be argued that a positive unit of electricity associated with a much smaller mass than the hydrogen nucleus may yet be discovered, it may be desirable not to prejudge the question by calling the hydrogen nucleus the positive electron. For this reason, and also for brevity, it has been proposed that the name "proton" should be given to the unit of positive electricity associated in the free state with a mass about that of the hydrogen nucleus, namely, about  $1.007$  in terms of  $O=16$ . A name for this unit will be found very convenient in discussing the inner structure of atoms. In the following, the term "electron" will be applied only to the well-known negative unit of electricity of small mass.

On the classical electrical theory, the mass of the electron can be accounted for by supposing that the negative electricity is distributed on a spherical surface of radius about  $1 \times 10^{-13}$  cm. This is merely an estimate, but probably gives the right order of magnitude of the dimensions, though it should be pointed out that in some recent theories of Compton and others it has been supposed that the electron behaves like a flexible ring, the dimensions of which are about  $10^{-11}$  cm., or about 100 times the original estimate. Without

going into these difficult questions, what little experimental evidence there is seems to me to support the older estimate of size. Taking the view based on the older theory, the greater mass of the proton is to be explained by supposing that the distribution of electricity is much more concentrated for the proton than for the electron. Supposing the shape spherical, the radius of the proton should be only  $\frac{1}{1800}$  of that of the electron. If this be so, the proton has the smallest dimensions of any particle known to us. It is admittedly very difficult to give any convincing proof in support of this contention, but at the same time there is no evidence against it. From the point of view of simplicity of explanation, it is natural to make the assumption that the proton and the electron are the fundamental units of which all atoms are built.

It would take too long to consider in any detail the gradual development in the last twenty years of our ideas on the structure of atoms. Progress has depended mainly on a clearer understanding of the relative part played by positive and negative electricity in atomic structure. It is now generally accepted that the atom is an electrical system and that the atoms of all the elements have a similar type of structure.

The nuclear theory of atomic constitution has been found to be of extraordinary value in offering an explanation of the fundamental facts that have come to light, and is now generally employed in all detailed theories of atomic constitution. At the centre of each atom is a massive positively charged nucleus of dimensions minute compared with the diameter of the atom. This nucleus is surrounded by a distribution of negative electrons which extend to a distance, and occupy rather than fill a region of diameter about  $2 \times 10^{-8}$  cm. Apart from the mass of the atom, which resides mainly in the nucleus, the number and distribution of the outer electrons, on which the ordinary physical and chemical properties of the atom depend, are controlled by the magnitude of the nuclear charge. The position and motions of the external electrons are only slightly affected by the mass of the nucleus. According to this view of the atom, the problem of its constitution naturally falls into two parts—first, the distribution and mode of motion of the outer electrons, and secondly, the structure of the nucleus and the magnitude of the resultant positive charge carried by it. In a neutral atom the number of external electrons is obviously equal in number to the units of positive (resultant) charge on the nucleus.

The general conception of the nuclear atom arose from the need of explanation of the very large deflections experienced by swift  $\alpha$ - and  $\beta$ -particles in passing through the atoms of matter. A study of the number of  $\alpha$ -particles scattered through different angles showed that there must be a very intense electric field within the atom, and gave us a method of estimating the magnitude of the charge on the nucleus. Similarly the scattering of X-rays by the outer electrons provided us with an estimate of the number of these electrons in the atom, and the two methods gave concordant values. The next great advance we owe to the experiments of Moseley on the X-ray spectra of the elements. He showed that his experiments received a simple explanation if the nuclear charge varied by one unit in passing from one atom to the next. In addition,

it was deduced that the actual magnitude of the nuclear charge of an atom in fundamental units is equal to the atomic or ordinal number when the elements were arranged in order of increasing atomic weight. On this view, the nuclear charge of hydrogen is 1, of helium 2, lithium 3, and so on up to the heaviest element uranium, of charge 92. It has been found that between these limits, with few exceptions, all nuclear charges are represented by known elements.

This relation, found by Moseley, between the atoms of the elements is of unexpected simplicity and of extraordinary interest. The properties of an atom are defined by a whole number which varies by unity in passing from one atom to the next. This number not only represents the ordinal number of the elements, but also the magnitude of the charge of the nucleus and the number of outer electrons. It could scarcely have been anticipated that, possibly with few exceptions, all nuclear charges between 1 and 92 would represent elements found on the earth. With the exception of the radio-active elements, the atoms are all stable for intervals represented by millions of years. The atomic weight of an element is not nearly so fundamental a property of the atom as its nuclear charge, for its weight depends upon the inner structure of the nucleus, which may be different for atoms of the same nuclear charge.

The most definite information we have of the structure of the nucleus has been obtained from a study of the modes of disintegration of the radio-active atoms. In the great majority of cases the atoms break up with the expulsion of a single  $\alpha$ -particle which represents the doubly charged nucleus of the helium atom; in other cases a swift  $\beta$ -ray or electron is liberated. There can be no doubt that these particles are liberated from the nuclei of the radio-active atoms. This is clearly shown by the variation of the atomic numbers of the successive elements in the long series of transformations of uranium and thorium (see Fig. 1). The expulsion of an  $\alpha$ -particle lowers the nuclear charge of the atom by two units and its mass by four, while the expulsion of an electron raises it by one. On this simple basis we can at once deduce the atomic number and, consequently, the general chemical properties of the long series of radio-active elements. In this way we can understand at once the appearance in the radio-active series of isotopes, *i.e.* elements of the same nuclear charge but different atomic masses.

The existence of isotopic elements was first brought to light from a study of the radio-active elements. For example, radium-*B*, radium-*D* and the end product, uranium-lead, are isotopes of lead of nuclear charge 82, but of masses 214, 210, and 206 respectively. As regards ordinary chemical and physical properties, they are indistinguishable from one another, differing only in properties that depend on the nucleus, namely, atomic mass and radio-activity. For example, radium-*B* and radium-*D* both emit  $\beta$ -rays, but with different velocities, while their average life is widely different. Uranium-lead, on the other hand, is non-radioactive. Many similar examples can be taken from the thorium and actinium series of elements. These illustrations show clearly that elements may have almost identical

physical and chemical properties and yet differ markedly in the mass and structure of their nuclei.

From the radio-active evidence it seems clear that the nuclear structure contains both helium nuclei and electrons. In the uranium-radium series of transformations, eight helium nuclei are emitted and six electrons, and it is natural to suppose that the helium nuclei and electrons that are ejected act as units of the nuclear structure. It is clear from these results that the nuclear charge of an element is the excess of the positive charges in the nucleus over the negative. It is a striking fact that no protons (H nuclei) appear to be emitted in any of the radio-active transformations, but only helium nuclei and electrons.

Some very definite and important information on the structure of nuclei has been obtained by Aston in his experiments to show the existence of isotopes in

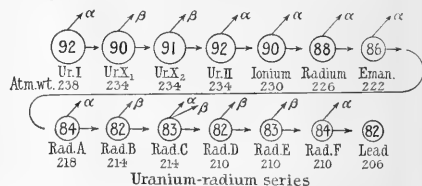

FIG. 1.

the ordinary stable elements by the well-known positive-ray method. He found that a number of the elements were simple and contained no isotopes. Examples of such "pure" elements are carbon, nitrogen, oxygen, and fluorine. It is significant that the atomic weights of these elements are nearly whole numbers in terms of  $O=16$ ; on the other hand, elements such as neon, chlorine, krypton, and many others consisted of mixtures of two or more isotopes of different atomic masses. Aston found that within the limit of error—about 1 in 1000—the atomic weights of these isotopes were whole numbers on the oxygen scale. This is a very important result, and suggests that the nuclei of elements are built up by the addition of protons, of mass nearly one, in the nuclear combination.

[Experimental evidence was here given of the liberation of protons from the elements boron, nitrogen, fluorine, sodium, aluminium, and phosphorus. See NATURE of May 6, p. 584.]

From the radio-active evidence, we know that the nuclei of heavy atoms are built up, in part at least, of helium nuclei and electrons, while it also seems clear that the proton can be released from the nuclei of certain light atoms. It is, however, very natural to suppose that the helium nucleus which carries two positive charges is a secondary building unit, composed of a close combination of protons and electrons, namely, 4 protons and 2 electrons.

From the point of view of simplicity, such a conception has much in its favour, although it should be mentioned that it seems at the moment impossible to prove its correctness. If, however, we take this structure of the helium nucleus as a working hypothesis, certain very important consequences follow. On the

oxygen scale, the helium atom has a mass very nearly 4.000, while the hydrogen atom has a mass 1.0077. The mass of the helium atom is thus considerably less than that of four free H nuclei. Disregarding the small mass of the electrons, in the formation of 1 gram of helium from hydrogen there would be a loss of mass of 7.7 milligrams.

It is now generally accepted that if the formation of a complex system is accompanied by the radiation of energy  $E$ , the reduction of the mass  $m$  of the system is given by  $E=mc^2$ , where  $c$  is the velocity of light. This relation between mass and energy follows not only as a direct consequence of the theory of relativity, but can be derived directly from Maxwell's theory, as pointed out by Larmor. On this relation, the energy  $E$  liberated in the formation of 1 gram of helium from hydrogen is equal to  $6.9 \times 10^{18}$  ergs or  $1.6 \times 10^{11}$  gramme-calories. This is an enormous amount of energy, large compared even with the total energy emitted during the complete disintegration of 1 gram of radium and its products, namely, about  $3.7 \times 10^9$  gramme-calories. It can be calculated that the energy radiated in forming one atom of helium is equivalent to the energy carried by three or four swift  $\alpha$ -particles from radium. On this view we can at once understand why it should be impossible to break up the helium nucleus by a collision with an  $\alpha$ -particle. In fact, the helium atom should be by far the most stable of all the complex atoms.

It has been pointed out by Perrin and Eddington that in all probability the energy of radiation from our sun and the stars is derived mainly from the enormous emission of energy accompanying the formation of helium from hydrogen. If this be the case, it is easy to show that sufficient energy can be derived from this source for our sun to radiate at its present rate for several thousand million years, whereas the older theories of Kelvin and Helmholtz, in which the heat of the sun is ascribed to the gradual concentration of the material under gravity, make the life of the sun much shorter than modern estimates of the age of the earth and appear to be quite inadequate to provide the requisite energy.

This interesting suggestion of the probable origin of the greater part of the enormous energy radiated by the sun and stars is one of the first-fruits of the investigations on the structure of atoms. It is believed that the formation of helium from hydrogen occurs under certain conditions in the great central furnace of the sun and stars, but there is no evidence, so far, that this combination can be produced under laboratory

conditions. It may be that it can be effected only under conditions of very high temperature and enormous intensity of radiation such as occur in the interior of a sun. Even then the process of formation may go on at a very slow rate and for periods measured by millions of years.

Most workers on the problem of atomic constitution take as a working hypothesis that the atoms of matter are purely electrical structures, and that ultimately it is hoped to explain all the properties of atoms as a result of certain combinations of the two fundamental units of positive and negative electricity, the proton and electron. Some of the more successful methods of attack that have been made on this most difficult of problems have been indicated. During recent years, unexpectedly rapid advances have been made in our knowledge, but we have only made a beginning in the attack on a very great and intricate problem.

Great difficulties arise the moment we consider why the nucleus of an atom holds together, and progress seems likely to be slow because it seems clear that the ordinary laws of force between electrified particles break down at such minute distances. There are, however, a number of obvious lines of attack that may yield us very valuable information. In particular, a closer study of the modes of transformation of radio-active bodies, where the process of devolution of elements takes place before our eyes, may be expected to give much important data. During recent years the study of the  $\gamma$ - or very penetrating X-rays from radio-active bodies has progressed very rapidly. The general evidence indicates that the  $\gamma$ -rays, like the  $\alpha$ - and  $\beta$ -particle, have their origin in the nucleus. The study of the  $\gamma$ -rays thus gives us information of the frequency of vibration of the electrons which form part of the nuclear structure. In addition, Ellis has shown that it appears probable that the laws of quantum dynamics which govern the motions and vibrations of the outer electrons apply also to the nuclear electrons. If this conclusion can be verified, it offers the hope that we may be able later to form some idea of the detailed structure of nuclei. There are also a number of other lines of evidence that will have to be taken into account in formulating any definite theory of the evolution of the elements; for example, Harkins has pointed out some very interesting relations that appear to exist between the relative abundance of elements in the earth and their atomic number, while the close study of stellar evolution should ultimately throw much light on the general problem.

### The Royal Botanic Society's Gardens.

THE gardens of the Royal Botanic Society, Regent's Park, are one of the landmarks of London. They occupy the whole of the Inner Circle of Regent's Park, an area of nearly 20 acres. The accompanying aerophotograph shows very well their main features. The Society was established by Royal Charter in 1839, "for the promotion of botany in all its branches, and its application to medicine, arts, and manufactures, and also for the formation of extensive botanical and ornamental gardens within the immediate vicinity of the metropolis." The first president was the Duke of Richmond, and the first secretary James

De Carle Sowerby, a botanist and artist, whose father, James Sowerby, was a well-known botanist in his time. The latter was author of "English Botany," a classic collection of coloured drawings of British plants, and other works. The son, James De Carle Sowerby, inherited his father's tastes as a botanist and artist. He also handed on to his son and grandson the office of secretary, the latter resigning shortly before the war.

Their Majesties the King and Queen and Queen Alexandra, and H.R.H. the Prince of Wales are patrons of the society, and the present President is Viscount Lascelles. The grounds of the gardens were originally

intended as the site for a royal palace, and had been used as a nursery garden. They were cleared and laid out as an example of English landscape gardening, an artificial lake being excavated and a mound formed near the centre of the ground in the process. In 1845 the conservatory was erected. It was the first large iron house built in England, the palm-house at Kew being constructed later. The herbaceous garden, in which the plants were arranged according to the natural orders, was also a novelty in its time. It

contains a warm-water tank in which *Victoria regia* is grown very successfully every year. In the late summer this is one of the sights of the gardens. In this house are also grown bananas, rice, bamboo, sugar cane, the sacred lotus, as well as a variety of tropical water plants and climbers. Some of the other houses are devoted to orchids, succulents, ferns, stove plants and bedding plants.

A practical gardening school was established in 1897, and has done excellent work. Lady gardening students

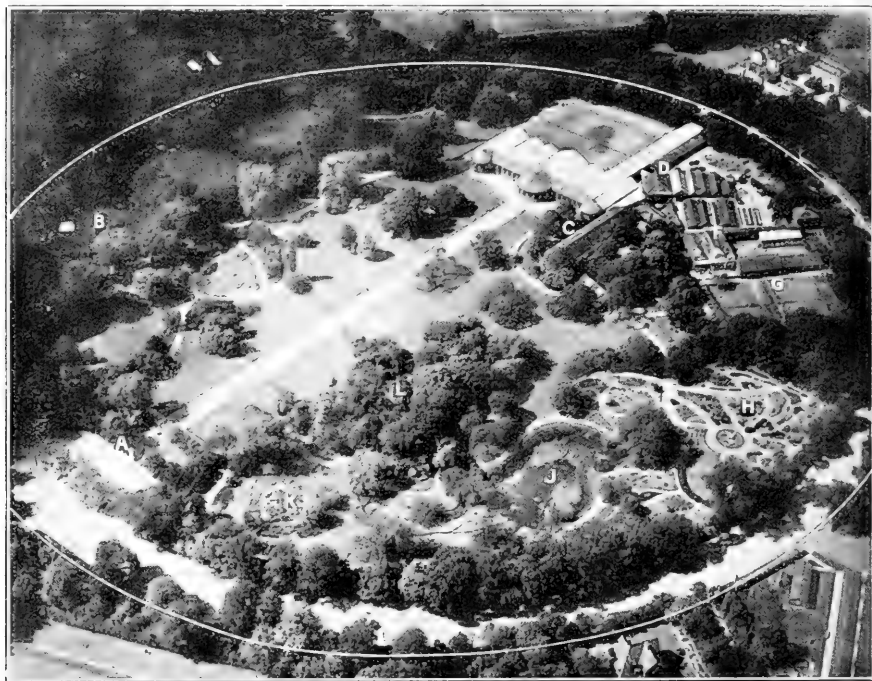

ROYAL BOTANIC GARDENS.

[Pics. by Central Aerophoto Co.]

A = MAIN ENTRANCE. B = MUSEUM AND LIBRARY. C = FELLOWS' ROOMS. D = VICTORIA REGIA HOUSE AND GREENHOUSES. E = CONSERVATORY. F = STUDENTS' HOUSE: PRACTICAL GARDENING SCHOOL. G = KITCHEN GARDEN. H = ORDER BEDS AND METEOROLOGICAL INSTRUMENTS. J = TOLL. K = ROCK GARDEN AND SURLIV. L = TOWER AND SUN RECORDER.

includes economic and medicinal plants, and has proved very useful to botanical students throughout the history of the gardens. As early as the 'eighties of last century 600-800 students' tickets were issued annually. The gardens have also been and are still an important source of specimens for botanical teaching in London. The kitchen-garden and rock-garden are other features having their special uses.

The greenhouses are now in need of replacement, and that process will begin shortly with the erection of two new and modern houses. The museum contains an important collection of economic products, particularly of tropical plants. The library is chiefly devoted to economic botany, including agricultural and horticultural publications. The Victoria House

were first admitted in 1904, and they have been very successful. They now number 22, and a new students' house was recently built for them. The course in practical gardening extends over three years, and includes practice in all the operations of gardening, as well as a certain number of lectures. Those who have completed the course have been very successful in the gardening competitions of the Royal Horticultural Society and in obtaining situations.

The gardens are also recognised as a meteorological station for London. The society possesses a complete set of instruments, and daily observations are made and published. The records include ground temperatures and sunlight.

In the years before the war the gardens ceased to

make progress and fell into debt. Beginning in 1906, a Commission from the University of London considered the possibility of incorporating them into the University and making them the centre of a Botanical Institute, but the scheme was not adopted. Since the war the gardens have taken on a new lease of life. An energetic Superintendent has been appointed, who has already increased considerably the utility and the amenities of the gardens. Ground has been set apart for genetic experiments under the direction of Prof. Ruggles Gates, of King's College, London. Several hard tennis courts have also been built, which are a considerable source of income.

In 1919 a Government Committee was appointed under the chairmanship of Sir David Prain, to consider how the work of the Royal Botanic Society could be made more useful from the scientific and educational point of view. Definite recommendations were made, which it is hoped will be carried into effect as funds become available. The recommendations included (1) the establishment of a School of Economic Botany, where a knowledge of economic and tropical plants and their products could be obtained; (2) an Institute of Research, especially on the living plant and its physiology; (3) a centre for teaching in horticulture; and (4) courses in school gardening for teachers.

When these are all carried out they will involve an annual expenditure of about 3000*l.* for salaries and expenses, and an initial outlay of some 5000*l.* for laboratories and equipment. Such an Institute of Economic Botany would be of enormous value to botany in this country, and in particular would contribute much to the economic development of our tropical possessions.

It is highly desirable that the necessary funds for this purpose should be forthcoming in the near future, so that the reconstruction of greenhouses and other buildings, which has become essential, can be carried out in a scheme harmonious with the present arrangements of the gardens. Botany in Great Britain has occupied in some respects a unique position, especially in its many-sidedness and in the closeness of the relations which have usually existed with economic, agricultural, and horticultural interests, and an Institute of Botanical Research of the kind recommended by the Government Committee in 1919 would probably do more than any other measure for the advancement of botanical science throughout the Empire. Any public-spirited citizen who would set the example of subscribing funds for this purpose would earn the gratitude of all those who have at heart the development of botanical science for the welfare of mankind.

### Obituary.

S. P. SMITH.

THE name of Stephenson Percy Smith, whose death is reported at New Plymouth, New Zealand, is probably more widely known than any other among students of Polynesian ethnology. Mr. Smith was born at Beccles in Suffolk, and arrived with his parents at the infant settlement of New Plymouth on February 7, 1850. In 1855 he entered the Government Survey Department, passing upwards through all grades and becoming Surveyor-General in 1889, a post which he held till his retirement in 1900. Among a number of important and arduous departmental undertakings carried through with conspicuous ability were the survey following the great eruption of Tarawera, and the mapping and charting of the Chatham Islands and the Kermadecs. His ability in affairs was recognised and made use of by the New Zealand Government on several occasions, perhaps most notably when he was dispatched to Niue, where he drew up the constitution under which that island has prospered ever since.

In spite of his varied services to the State, it is in another capacity that he will be best remembered, namely, as the leading authority on Polynesian traditions. A few months before his death a fourth edition appeared of "Hawaiki: The Whence of the Maori," a book which has been more widely read and more often quoted than any other modern work on Polynesia. In its latest form it has been considerably expanded, and it is weightier and more mature, even, than before. He published several other books dealing with the Maori, and a very large number of papers, every one of which is of value.

A service to ethnology almost as important as the publication of his own works was performed by Percy Smith in the capacity of president of the Polynesian Society and editor of its Journal. He was the most prominent of its founders in 1892, and he presided over

it and guided it until his death. Thirty volumes of the Journal have appeared, and the immense industry and the scholarship involved in editing them and in translating numberless papers published in them, would alone constitute a notable life-work. By thus providing a means for the rapid publication of ethnological research in New Zealand and the Pacific he performed a service for anthropology in that part of the globe probably greater than has been rendered by any other worker in the field. He was an honorary member of many scientific societies in different parts of the world, and in New Zealand had been honoured by a Fellowship of the New Zealand Institute, and by the award of the Hector Medal.

No one could meet Percy Smith without recognising the strength and range of his intellect. He rendered ready help alike to great and small. His loss will be felt not only by those who knew him personally and experienced his generous help, but by every student who begins research in the field of which he was the unchallenged master.

H. D. S.

WE notice with regret the announcement of the death, on July 27 last, of Dr. A. J. Harries. Dr. Harries, who was born in 1856 and received his medical education in London and Brussels, was well known for his work on electro-therapeutics and kindred subjects. Among a number of medical works which he published was "A Manual of Electro Therapeutics," issued in 1890; he was also the author of papers on the dangers and uses of electricity, including one contributed to the Leeds meeting of the British Association in 1890, in which it was pointed out that current strength, as well as voltage, is an important factor in estimating the danger to life from accidental contacts with "live" wires and structures.

## Current Topics and Events.

DR. E. T. WHITTAKER, professor of mathematics in the University of Edinburgh, has been elected a Foreign Member of the Reale Accademia dei Lincei, Rome.

SIR CHARLES PARSONS, inventor of the Parsons steam turbine, Dr. J. H. Tuftsbery, until recently secretary of the Institution of Civil Engineers, and Mr. C. le Maistre, Secretary of the International Electro-Technical Commission in London, have been elected honorary members of the Royal Dutch Institute of Engineers.

THE D. G. Elliot gold medal of the National Academy of Sciences of the United States of America has been awarded to Dr. O. Abel, professor of palaeobiology in the University of Vienna for his work, "Methoden der paläobiologischen Forschung," which forms a part of Abderhalden's "Handbuch der biologischen Arbeitsmethoden."

THE Franklin Gold Medal of the Franklin Institute of Philadelphia was presented on July 26 by Lord Balfour to Sir Joseph J. Thomson, in the presence of a distinguished gathering of men of science from Great Britain, Canada and the United States of America. This medal, which was instituted in 1914 by Samuel Insull, is awarded annually "to those workers in physical science or technology, without regard to country, whose efforts . . . have done most to advance a knowledge of physical science or its applications."

MR. W. H. DINES, Director of the Aerological Observatory of the Meteorological Office at Benson, has retired after many years' service in connexion with the upper air. The *Meteorological Magazine* for July, speaking of his retirement, mentions Mr. Dines as a link with the past. After a training in mechanical engineering, and with a Wrangler's degree at Cambridge, he was specially qualified to undertake the direction and management of an observatory for the upper air. Much of his earlier work was effected with kites. The upper air work is said by Sir Napier Shaw to have been successful beyond hope and expectation, though both were high, and pre-eminence is claimed for the high-water mark of the investigations in this country. Mr. Dines's services to science and the State have been of the highest order and of very special value during the development of aircraft and engines, and the maximum result has been achieved with the minimum of cost. His payment as Director was a small honorarium and out-of-pocket expenses.

A LOAN collection of water-colours of New Zealand, by Mr. C. N. Worsley, is at present being shown in the New Zealand Court of the exhibition galleries of the Imperial Institute. The pictures give an excellent impression of the beauty of the scenery of New Zealand. Among the new collections recently added to the galleries is a representation of the resources of British North Borneo, which includes an exhibit illustrating the important tobacco industry.

NO. 2753, VOL. 110]

THE annual exhibition of the Royal Photographic Society for the present year will be held at 35 Russell Square, W.C.1, from September 18 to October 28, inclusive. The exhibition will comprise the following sections: Pictorial Prints, Pictorial Lantern Slides, Pictorial Colour Transparencies and Prints, Natural History Subjects, Photomicrographs, Radiographs, Astronomical, Aerial, and Spectrum Photographs, Stereoscopic Slides, Scientific Colour Work, and Technical Applications of Photography.

A CONFERENCE of representatives of the various branches of the dairy industry in this country, held on July 28 at the Ministry of Agriculture, under the chairmanship of Sir Francis Floud, was addressed by Prof. H. E. Van Norman, president of the World's Dairy Congress which it is proposed to hold in October 1923 at Philadelphia. At the conclusion of the meeting, the following resolution was passed:—"That this meeting, having heard Professor Van Norman's statement of the objects, etc., of the World's Dairy Congress to be held in the United States of America in October 1923, is of opinion that this country should be adequately represented at the Congress, and it requests the Ministry of Agriculture in conjunction with the Ministry of Health to invite the various Associations and bodies interested in the Milk Industry to nominate representatives to serve on a General Committee to organise the representation of the Industry in England and Wales at the Congress."

MR. NORMAN L. SILVESTER sends us from Pangbourne, Berks, a specimen of Scabious having a remarkable malformation of the head. Presumably a case of forking of the original bud, one "half" has grown to produce a complete head, the other "half" has remained short and produced a few florets only.

MR. K. NORRIS, Purley, writes to record that an albino crested newt (*Molge crestata*) was found in a pond at Sanderstead, Surrey, on Friday, June 30. Instead of the usual form, dark grey or blackish brown, with orange underparts blotched with black, the specimen is creamy white with pink eyes. It is at present exhibited at the naturalist's stores of Mr. G. A. Bentall, 392 Strand, W.C.2.

WE recently mentioned (July 8, p. 54) a communication by Mr. Hazeldene Warren published in the June issue of *Man*, on the subject of the Red Crag Flints of Foxhall. In the July issue of *Man* Mr. J. Reid Moir presents a rejoinder to Mr. Warren's criticisms. We cannot find space for further reference to the discussion, but think it worth while to direct attention to Mr. Moir's reply.

IN an article on radio direction-finding in flying machines in *NATURE* of July 8, p. 59, it was stated that Mr. Gregory Breit worked out mathematically the nature of the field from the two horizontal coils which are used, but no other names are mentioned. Mr. Breit now writes to point out that the work on

direction-finding was carried out by Messrs. Kolster and Dummore, and that the use of two horizontal coils as a transmitter was due to Mr. Willoughby. Mr. Breit's own work was confined to the calculation of the radiation from the Willoughby transmitter.

THE Imperial Bureau of Mycology, in addition to its other activities, has recently begun the publication, under the editorship of the director, Dr. E. J. Butler, of the *Review of Applied Mycology*. One of the important functions of the Bureau is the accumulation and distribution of information on all matters connected with the diseases of plants, and the co-ordination of investigations in this particular field of study to enable workers in all parts of the world to keep in touch with recent research. In order that this may be accomplished a complete index of the literature is to be kept, and abstracts of the more important investigations will be pub-

lished. The review is being issued monthly and several numbers have already appeared. The importance of a periodical of this kind issued by a competent authority is obvious, and if only the abstracting can be maintained at its present high level and the review published punctually, with abstracts well up-to-date, it will be of great service to economic mycologists.

MAJOR T. F. CHIPP, Conservator of Forests, Gold Coast, since 1921, and previously assistant director of the Botanic Gardens, Singapore, has been appointed assistant director of the Royal Botanic Gardens, Kew. Major Chipp received part of his early training at Kew and worked as a temporary technical assistant in the Herbarium. Later he went as demonstrator in botany at the Birkbeck College, and in 1910 was appointed an assistant Conservator of Forests in West Africa.

### Our Astronomical Column.

LARGE FIREBALL ON JULY 26.—The Toronto correspondent of the *Times*, in a message dated July 26, reports that a loud explosion shook the ground for 20 miles round Wynward, Saskatchewan, and that a giant meteor was seen to fall into the Big Quill Lake. A large fiery ball was observed by many persons in the district to drop from the clear sky, and after it had sunk in the waters of the lake, clouds of steam are said to have risen from the surface.

Other reports have come from Vanscoy, south-east of Saskatoon, which is in longitude  $107\frac{1}{2}^{\circ}$  west, and north latitude  $52\frac{1}{2}^{\circ}$ . The inhabitants of this neighbourhood heard five or six explosions, and the ground lying between Vanscoy and Pike Lake was severely shaken.

No further details of a definite character have yet been received, and it is difficult from the information at hand to draw safe conclusions other than that a large fireball descended near the places named, and apparently fell to the earth. The date of July 25 or 26 is one when large meteors are usually abundant. The principal shower is sometimes directed from near the stars  $\alpha_1$  and  $\alpha_2$  Capricorni. The meteors of this shower are often brilliant, and they traverse long paths with slow motion. It is quite possible that one of the objects composing this stream may have fallen to the earth, and is identical with the fireball observed.

THE SYSTEM OF CASTOR.—This interesting system has been the subject of much research since the earliest known observation of it as a binary by Bradley and Pound in 1719. The determination of the period was nearly hopeless until comparatively recently; until 40 years ago some computers put forward values so large as 1000 years. But with the approach to periastron, which is due in some 30 years, the problem is simplified, and Mr. W. Rabe, in an exhaustive study of the system in *Astr. Nach.*, No. 5164-5, gives the following elements:  $a = 6^{\circ}.06$ ,  $e = 0.5593$ ,  $i = 66^{\circ}.79$ ,  $\omega = 81^{\circ}.97$ ,  $\Omega = 32^{\circ}.55$ ,  $T = 1954.73$ , Period 306.28 years. The probable error of the period is given as 5 years. The orbit coincides practically with the minimum ellipse drawn by Mr. Lewis in his Memoir on the Struve double stars. The analysis of the observations by Mr. Rabe supports the suggestion, first vaguely made by Mr. Burnham (Mon. Not. R.A.S., vol. 51), that the fainter star has

a fairly close unseen companion, the period being about  $8\frac{1}{2}$  years. The spectroscopic observations of radial velocity are stated to agree with this hypothesis. The parallax of the system is discussed, and the value  $0^{\circ}.0745$  adopted. The combined mass is then 5.74 in terms of the sun; Rabe assigns 3.33 of this to the brighter star, 2.41 to the fainter. If the supposed unseen companion is real then its mass accounts for 0.60 of the 2.41.

Both of the visible stars are spectroscopic binaries, and from the velocities measured it had been conjectured that the fainter star was the more massive. This, however, involved the doubtful assumption that the spectroscopic orbits were coplanar with the principal orbit, an assumption rendered improbable by Mr. Rabe's discussion. As the distant companion C is also a member of the system, there would seem to be at least six components altogether.

The proper motion of the centre of gravity could not be given till the mass-ratio was determined. Mr. Rabe gives it as  $-0^{\circ}.0134$  in R.A., and  $-0^{\circ}.108$  in Decl. Combining this with the radial velocity, and correcting for solar motion, the true velocity is 10.46 km./sec. towards R.A.  $305^{\circ}.5$ , Decl.  $+42^{\circ}.5$ . This agrees with the motion of a group of 22 A-stars of Drift I discussed by Prof. Plummer.

THE DOMINION ASTROPHYSICAL OBSERVATORY, VICTORIA.—Publication No. 26 of vol. i. of this observatory contains a list of 88 new spectroscopic binaries discovered there, in addition to the first 100 announced in No. 10. The spectrograph is mounted on the 72-inch reflector which is used as a Cassegrain with equivalent focal length 100 feet. Analysis of the stars shows that they are distributed through all spectral types, but 90 per cent. belong to types B, A and F. Of the B-stars about every second one investigated proved to be binary, suggesting that duplicity may be the normal accompaniment of the attainment of this type, for in some cases the variable velocity would not be detected if its component in the line of sight was small. The following star of the pair  $\Sigma$  1890 (separation  $3^{\circ}.5$ ) is one of the stars on the list. The preceding star has a fixed velocity, while the following one shows in the violet "beautiful sharp double lines with a separation of about 70 km." Another star is Boss 4777, which is the distant companion ( $46^{\circ}$ ) of  $\beta$  Lyrae.

## Research Items.

**THE KWAKIUTL INDIANS.**—The report of the Peabody Museum of American Archaeology and Ethnology, at Harvard University, for 1920-1921, published in 1922, records the results of many expeditions. The one of chief interest to British readers is a visit to the Kwakiutl Indians of British Columbia, made by Dr. C. F. Newcombe, to look for the few remaining house-posts or other large carvings of those Indians. From Kalukwis village on Tournour Id. he secured two fine house-posts, about sixteen feet high and nearly four feet across. Each is carved with figures representing the speaker of the chief and the ancestral grizzly bear who was friendly to the founder of the family, giving him rights to certain dances, and teaching him the use of the appropriate masks. These carvings are now on exhibition, and a house group of Kwakiutls has been added to the fourteen previously illustrating the home life of the American Indians. A new Hall of North American Ethnology was opened to the public in September 1920, but it needs more cases before the collections can be finally arranged. With the reduction in the price of plate glass, it is hoped that these cases will soon be added.

**THE ETHNOLOGY OF SCANDINAVIA.**—Prof. H. F. Osborn contributes to *Natural History* of April last (vol. xxii, No. 2) an article entitled "Our Ancestors arrive in Scandinavia," in which, with good illustrations, he sums up the latest conclusions on its archaeology. From the chronological table he argues that "it becomes apparent that what the far-distant north-west was to our American pioneers, what Ultima Thule was to ancient historic times, such was Scandinavia to the people of the Mediterranean borders. In the course of thousands of years implements, symbols, and inventions—useful, religious, or artistic—slowly found their way westward and northward, from Eastern Asia to Sweden, a distance which, thanks to the telephone, is to-day spanned in a few seconds. For example, copper is said to have been used at Anau, Turkestan, about 4000 B.C., and first appears in Sweden 1500 years later—namely, 2500 B.C. The Age of Bronze, which was in full sway in Egypt and Chaldea by 3000 B.C., makes its first appearance in Sweden eight hundred years later. Thus within a period of eight thousand years our ancestors arrived in Scandinavia and passed through a long hunting stage of evolution with only flint implements; through all the Neolithic phases; through a superb development both of the art of flint and of bronze; into the culminating period of the Age of Iron."

**THE FORGING OF FINGER-PRINTS.**—It is disconcerting to learn from an article by Mr. J. C. Goodwin in the third number of the new publication, *Dactylography*, that the practice of forging finger-prints is increasing and will soon become a problem for New Scotland Yard. The criminal must first obtain specimens of the prints of the dupe on whom he intends that suspicion should fall. This he does by arranging that the dupe leaves his prints on a glass, or on a polished piece of furniture, after which the prints are photographed. One method of forging involves the use of a rubber stamp, where a facsimile of the original is reproduced on the rubber by means of transfer paper, and the surrounding rubber deftly pared away with a sharp knife. The second method is to take a negative cast of the finger to be forged by pressing it into a mould of soft wax, plaster of Paris, clay, or even bread. A third process involves

photographing a photograph of the prints to be forged on a reversed plate, which is clamped to a duplicate plate made of gelatine mixed with bichromate of potassium. The two are exposed to the light, with the photographic negative nearer to the light, and the sensitised surface touching the gelatine.

**FOSSIL FISH FROM SOUTHERN ITALY.**—Prof. Geremia D'Erasmus describes and figures in the Rendiconto dell' Accademia delle Scienze, Napoli (Ser. III., vol. xxviii.), some fossil fish from southern Italy. They comprise an almost complete Picnodont (*Calodus costati*, Heckel) from the cenomanian beds of Alessano, province of Lecce, where examples of this group are scarce; a *Leptolepis* from the cretaceous of Roccavedandro, province of Caserta; as well as a *Seriola*, a *Thynnus*, two species of *Clupea*, and a *Pelamys* from the pleistocene strata of Taranto.

**REDESCRIPTION OF AN EOCENE LIZARD.**—Discovered and described fifty years ago, the remains of *Saniwa ensidens*, Leidy, from the Bridger deposits (Eocene) of Wyoming, have only recently been properly developed from the matrix. The unusual perfectness of the skeletal remains thus revealed have justified their redescription by Mr. C. W. Gilmore (Proc. U.S. Nat. Mus., vol. lx.). The fossil proves to be a true member of the family Varanidae, which therefore contains the genus *Varanus*, largely made up of living species of lizards, and the genus *Saniwa*, which now includes six or more extinct species, since Marsh's *Thinosaurus* is considered by the author as congeneric with *Saniwa*.

**OWL FROM THE EOCENE OF WYOMING.**—A fragment of a humerus and two vertebrae from the Bridger deposits of Wyoming were referred in 1873 by Dr. J. Leidy to a lizard which he named *Saniwa major*. The humerus is now shown by Mr. A. Wetmore (Proc. Acad. Nat. Sci., Philadelphia, vol. lxxiii.) to be avian and to represent an owl of the family Bubonidae, similar in size to *Pulsatrix perspicillata*, Latham. It does not resemble closely any existing genus of modern North American owls, but in a way combines characters pertaining to several. The author assigns it tentatively to Shufeldt's genus *Minerva* under the new trivial name of *M. sawoodosis*, but admits that that genus, founded on a claw at first referred to *Aquila*, although from the same formation and district, may yet prove to be an incorrect receptacle for the new species.

**SYSTEMATIC BOTANY.**—The forty-seven articles of the latest volume of the Kew Bulletin (Bulletin of Miscellaneous Information, Royal Botanic Gardens, Kew, 1921; 10s. net) are an index of the activities of the Royal Gardens. They are mainly of systematic interest, including revisions of genera, descriptions of novelties, and notes on plants of botanical or economical importance. A point of general interest which emerges is the indication of the great amount of work which remains to be done before we can have an accurate knowledge of the constituents of the floras of the different parts of the world. The revision of the *Stipa* grasses of Australia (by Miss D. K. Hughes) indicates 40 distinct forms in place of the 15 hitherto recognised; it also bears out the common experience, that variation in anatomical structure of the leaf-blade of grasses does not run parallel with the characters of leaf and flower from which we infer their relationships. The incomplete state of our knowledge of the Central American forest flora is well illustrated by a revision of the genus *Belotia*, and of the family *Tiliaceae*, in which T. A. Sprague distinguishes eleven species, an increase of six on the number hitherto recognised.



A difficulty which the economic botanist frequently meets is illustrated by an inquiry (by S. T. Dunn) into the cause of the variability in the yield of camphor from the Camphor tree (*Cinnamomum Camphora*). Some trees are found to be worthless, the oil yielding no solid camphor on distillation. Careful examination discloses no perceptible botanical difference between good and worthless trees, but there may be peculiarities which affect only the chemical products of the tree. Such physiological varieties are known in rubber and timber trees. Investigation indicates that climatic conditions, the age of the leaves when cut for distillation, and the general health of the tree have an important bearing on the yield.

**BRITISH AND IRISH PAGURIDEA.**—The Paguridea (including hermit crabs and the stone crab) which have been found on the coasts of Ireland had been studied by Mr. C. M. Selbie, of the National Museum, Dublin, who died at the Somme in July 1916. The account now published (Fisheries, Ireland, Sci. Invest. 1921, I.) has been completed from Mr. Selbie's rough drafts by Dr. S. W. Kemp. The material reported upon, nearly all obtained by the Irish Fishery Cruiser, contains eleven species, one of which—*Nematopagurus longicornis*—has not hitherto been known from British waters. To complete the list of British and Irish representations of this tribe there are to be added an Irish species of *Eupagurus* recorded in 1866, and two species—one *Diogenes* and one *Anapagurus*—known from the shores of Great Britain but not yet discovered in Irish waters—a total of fourteen species. The majority of the species inhabit water that is shallow or of moderate depth, but one—*Parapagurus pilosimanus*—is a true deep-water species and occurs at depths ranging from 250 to 2260 fathoms. Three of the fourteen species extend north of the Arctic Circle and eight are found in the Mediterranean. There are keys to the families, genera, and species, and a systematic account is given of each species with notes on its distribution.

**THE SEMI-DIESEL ENGINE.**—Owing to the high price of fuel in France at the present time the Mechanical Arts Committee of the Société d'Encouragement pour l'Industrie nationale has thought it desirable to publish an account of the present position of the semi-Diesel engine, and in consequence the May issue of the Bulletin of the Society contains an article of nearly 100 pages on the subject from the pen of M. A. Schubert. It goes into the theory of the engine, the reasons which have led to its development, the forms which it at present takes in France and in other countries, and the oils which can be used in it. Under the last head the author deals especially with the vegetable oils which are produced in great quantities in the French colonies in Africa and in Asia. It concludes with a short account of the tests of such engines carried out recently by the Society in conjunction with the Automobile Club of France and the marine and agricultural authorities. From the results we gather that several engines of horse-powers from  $2\frac{1}{2}$  to 50 show a consumption of oil of the order of 320 grams per h.p. hour, while one of 20 to 30 h.p. consumes 247 grams only. M. Schubert's article, while intended primarily for French engineers, will be found of great value by the engineers of this country.

**UNDERGROUND WORKROOMS.**—In the Annual Report of the Chief Inspector of Factories for 1921 special reference is made to conditions in underground workrooms. Of the 300 rooms inspected during the inquiry a number were expressly designed for use as workrooms and the conditions were satisfactory. But others were never intended for use in this way and the structural conditions render it im-

possible to secure good lighting, ventilation and sanitary conditions. Of the rooms visited about 61 per cent. were provided with means for flushing the rooms with air, in 20 per cent. the through ventilation was only partial, and in 19 per cent. it appeared that there was practically no through ventilation. It was considered that the state of the air was fresh or satisfactory in 68 per cent. of the rooms, while in 24 per cent. it appeared to be close or stale, and in 8 per cent. stagnant. In approximately 78 per cent. of the rooms the natural light was deemed insufficient to light the whole of the room, but, fortunately, in most cases the artificial lighting was considered satisfactory in intensity although glare due to imperfectly screened lamps appears to be common. There is no doubt that access of light through windows is often neglected; in some cases broken windows are obscured by sacking, cardboard, etc. Daylight is undoubtedly superior to all but the very best artificial lighting, and the effect of a mixture of daylight and artificial light is rarely satisfactory. Every effort should therefore be made to secure the maximum admission of natural light in underground buildings. Another drawback to the use of basements as workrooms is the tendency for dust to enter from the pavement outside. Mention is made of a case where a trough fitted under a grid ventilator at pavement level was found to be filled by about a quart of black dust. Muslin or gauze is sometimes fitted over ventilator-entries to prevent dust entering, but the pores of the material are liable to become choked and it requires frequent washing.

**A CHEMICAL SPECTROMETER.**—A spectrometer of entirely novel design has recently been produced by Messrs. Adam Hilger, Ltd., of 75a Camden Road, N.W.1. By the application of an autocollimating telescope the designer has been enabled to dispense with the collimator tube of the ordinary spectrometer.

The arrangement of the components is shown in the sectional drawing, Fig. 1. The eye-piece E of the telescope contains, on the left, the slit and small auto-collimating prism for introducing the light which, after passing through the object glass O, proceeds to the  $30^\circ$  prism P, is reflected from the silvered back surface and re-traces its path through the object glass to the eye-piece where the spectrum is viewed. The prism is rotated by means of a micrometer screw which is attached to a drum D giving readings direct in wave-lengths. The design of the instrument renders it extremely compact. In size and external appearance it is similar to a microscope and occupies about the same amount of table space.

It has the additional advantage of ease in setting up, convenience in manipulation and low cost, compared with a spectrometer of the ordinary type having a similar degree of accuracy. Such an instrument should tend to encourage the more general use of spectroscopic measurements in chemical laboratories.

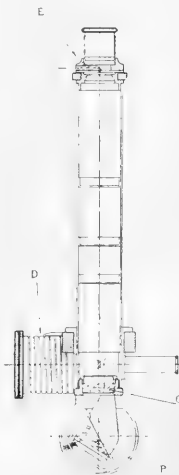

FIG. 1.

## The Norman Lockyer Observatory.

UNVEILING OF A PORTRAIT MEDALLION OF THE FOUNDER.

ON Saturday, July 22, a portrait medallion of Sir Norman Lockyer was unveiled by the Astronomer Royal, Sir Frank Dyson, at the Norman Lockyer Observatory, Salcombe Hill, Sidmouth, in the presence of a large and distinguished company. The medallion, which had been executed by Sir Hamo Thornycroft, R.A., was erected in honour of the

late Sir Norman Lockyer by his relatives and friends, and was presented by them to the Corporation of the Observatory. (A reproduction of the medallion, with the accompanying inscription, is illustrated in Fig. 1.) The guests were received on behalf of the Observatory Corporation by Sir Richard Gregory (chairman of the council), Mr. Robert Mond (chairman of the Corporation), and by Lady Lockyer. Much interest was taken by the guests in the exhibits arranged in connexion with the work of the observatory, the McClean and Kensington telescopes and other instruments.

In opening the proceedings Sir Richard Gregory remarked that they had assembled to take part in a ceremony of high significance both to the county of Devon and to British science. On the summit of Salcombe Hill, with its clear and wide horizon, they had united to dedicate with affection and esteem a memorial to the great astronomer, Sir Norman Lockyer, who had planted the observatory there. The event was one in which they might all be proud to participate, whether as Sir Norman's personal friends, as admirers of his life and influence, or as scientific students familiar with the remarkable advances of astronomical physics originated by him or inspired by his genius. His discoveries were inscribed upon the tablets of the stars, and in this temple of the skies

they now met to manifest in reverence the honour in which they held him.

Lt.-Col. F. K. McClean said that he regarded it as a great honour to present, on behalf of relatives and friends, the medallion, so faithfully executed by Sir Hamo Thornycroft, to the observatory. It was his good fortune to have been associated with Sir

Norman in the foundation of the observatory in 1912. Through the energy and enthusiasm of Sir Norman the observatory has proved a successful enterprise, and commencing as a private institution it has become a Corporation and is the first of its kind in this country. American observatories are more useful now, but the Norman Lockyer Observatory, though at present a baby, will grow and develop; and what its future may be can be seen by looking at the Mount Wilson, Yerkes, and Lick Observatories. So long as the observatory lasts, the name which it has the honour to bear will be the watchword of advance.

THE ASTRONOMER  
ROYAL'S  
TRIBUTE.

Sir Frank Dyson, in unveiling the memorial, said:

This portrait medallion is a pious tribute of relatives and friends to the memory of a man

of genius. It recalls to our minds the features of a man we have known and honoured, and preserves his likeness for future generations. The name of Sir Norman Lockyer will always be associated with the application of the spectroscope to the study of the sun and stars. In this beautiful medallion Sir Hamo Thornycroft has given a true and striking portrait of a very earnest worker and great pioneer.

Like David Gill, another astronomer whom most of us know, Lockyer began as an amateur with

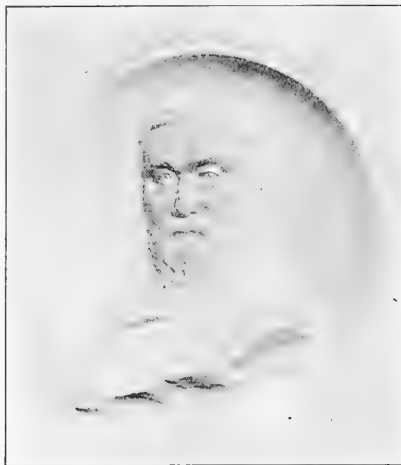

FIG. 1.—Portrait Medallion of Sir Norman Lockyer.

17TH MAY, 1836—16TH AUGUST, 1920  
TO THE ENDURING MEMORY OF THE GENIUS AND CONSTRUCTIVE IMAGINATION OF  
**SIR NORMAN LOCKYER, K.C.B., F.R.S.,**  
CORRESPONDANT DE L'INSTITUT DE FRANCE  
HON. LL.D., GLASGOW, ABERDEEN AND EDINBURGH; HON. SC.D., CAMBRIDGE AND SHEFFIELD;  
HON. D.S.C., OXFORD.  
FOUNDER AND DIRECTOR OF THE SOLAR PHYSICS OBSERVATORY, SOUTH KENSINGTON, 1885-1913; AND OF THIS OBSERVATORY, 1913-1920.  
FOUNDER AND EDITOR OF "NATURE," 1865-1919.  
PIONEER IN THE INVESTIGATION AND INTERPRETATION OF THE CHEMISTRY OF THE SUN AND STARS AND IN THE SCIENCE OF ASTRONOMICAL PHYSICS.  
DISCOVERER OF HELIUM IN THE SUN AND ORIGINATOR OF THE THEORY THAT HELIUM AND HYDROGEN ARE THE ULTIMATE PRODUCTS OF THE DISSOCIATION OF MOLECULES AND ATOMS.  
FOUNDER OF THE SYSTEM OF STELLAR CLASSIFICATION BASED UPON ASCENDING AND DESCENDING TEMPERATURES IN ORDERLY CELESTIAL EVOLUTION.  
REVEALER OF THE ASTRONOMICAL SIGNIFICANCE OF STONEHENGE AND OTHER ANCIENT MONUMENTS.  
FOUNDER OF THE BRITISH SCIENCE GUILD FOR THE PROMOTION AND APPLICATION OF SCIENTIFIC METHOD TO PUBLIC AFFAIRS.  
THIS PORTRAIT WAS ERECTED BY RELATIVES AND FRIENDS.

a telescope in his garden and devoted his spare time to astronomy. The two men were alike in their energy and intense enthusiasm. One sees on nearly every page of his book on "Solar Physics," published in 1893, the delight which Sir Norman took in his work. He makes one feel that the years following Kirchhoff's explanation of the dark lines in the solar spectrum were glorious times for astronomers, who suddenly found a way to explore the chemical and physical constitution of the heavenly bodies. One could scarcely say that each day brought a new victory, but new victories and new problems followed one another very rapidly.

When Sir Norman Lockyer commenced his work in 1866, current views on the constitution of the sun were very different from those we now hold. Although Herschel's idea of the cool dark interior had been given up, some traces of its influence still remained. Faye conceived of the interior of the sun as a nebulous gas of feeble radiating power at a temperature of dissociation: the photosphere, on the other hand, being of a high radiating power and at a temperature sufficiently low to permit of chemical action. In the sunspot we see the interior nebulous mass. Balfour Stewart and De la Rue were opposed to this view and explained a sunspot as due to an inrush of matter from the sun's atmosphere into the photosphere. With a small direct-vision spectroscope on a  $6\frac{1}{2}$ -inch equatorial, Sir Norman Lockyer examined the spectrum of a sunspot and compared it with that of the surrounding photosphere. He found no bright lines, but the same absorption lines as in the solar spectrum, and so far as he could judge with his small dispersion rather broadened. This supported Balfour Stewart rather than Faye. In a paper communicated to the Royal Society he laid stress on the importance of *detailed spectroscopic study of the sun's surface*. He also puts the question, "May not the spectroscope afford us evidence of the existence of the 'red flames' which total eclipses have revealed in the sun's atmosphere; although they escape all other methods of observation at other times?"

With the aid of funds from the Government Grant Committee he proceeded to construct a solar spectroscope of sufficient dispersion, and on October 20, 1868, wrote to the Royal Society: "After a number of failures which made the attempt seem hopeless I have this morning perfectly succeeded in obtaining and observing part of the spectrum of a solar prominence. As a result I have established the existence of three bright lines in the following positions:

- I. Absolutely coincident with C.
- II. Nearly coincident with F.
- III. Near D.

The third line is more refrangible than the more refrangible of the two darkest lines by eight or nine degrees of Kirchhoff's scale."

A similar communication was made to the French Academy of Sciences, and in addition, the form of the prominence was roughly drawn. The letter to the French Academy was followed by a communication received the same day from M. Jannsen reporting the success of an expedition to observe a total solar eclipse. During the eclipse the idea had occurred to him of how the red flames could be made visible without an eclipse, and he carried it out on the following day. In this dramatic manner the observations of prominences was started, and their gaseous nature proved. The French Government struck a special medal in memory of the discovery and in honour of the discoverers.

Observation of prominences was after this success carried on with renewed vigour. By the simple device of widening the slit the forms of the prominences were seen in C or F light. A further important

discovery was made almost at once. Sir Norman Lockyer found that bright C and F lines were visible all round the sun. In this way was discovered the existence of a continuous envelope round the sun of fairly uniform height except where it was heaped with prominences. This envelope was named the chromosphere and it was estimated to be about 5000 miles thick.

The behaviour of the F line, which is described as sometimes exceedingly brilliant and widening out so as to present a bulbous appearance above the chromosphere, and the existence of the line near D with no corresponding Fraunhofer line, suggested work in the laboratory. This was undertaken in conjunction with Edward Frankland. These investigations showed that the yellow D<sub>3</sub> line could not be obtained in the spectrum of hydrogen, however the conditions were varied. It was attributed by them to a new element, a light gas, as yet undiscovered on the earth, and the name helium was given to the element producing the line. As is well known, the D<sub>3</sub> line and allied lines were found to have great importance in stellar spectra, and in 1895 was found by Ramsay in a gas from the mineral cleveite. The subsequent history of helium and the prominent part it has played in physical science makes its initial discovery by Lockyer in the sun, twenty-six years before it was found on the earth, a most interesting episode in the history of science.

These laboratory experiments of Lockyer's and Frankland's are of great importance. Sir Norman had a strong conviction, at this early date, that research should be carried on concurrently in the observatory and the laboratory. The spectra found in the observatory were to be interpreted by experiments on the differences produced by temperature, pressure, and varied methods of electric excitation. In this way spectroscopy would lead to knowledge not merely of the chemistry, but of the physical conditions of the heavenly bodies. One immediate conclusion was that the continuous spectrum did not necessitate a solid or liquid photosphere but could arise from a gaseous body. Further, that the absorption indicated by the Fraunhofer lines may take place in the photosphere itself, or very near it, and not in an extensive outer absorbing atmosphere. How fruitful this method of research became in his hands and those of his pupils we all know.

At South Kensington his work was to a large extent a natural development and exposition of the views he had previously formed. The idea of the dissociation of elements at increasing temperature led to a very extensive comparison of the arc spectra of metals with those obtained in the higher temperature or more intense electric conditions of the spark. In 1881 he found that the iron lines 4924.1 and 5018.6 were greatly enhanced in brightness when one changed from the arc to the spark spectrum. The lines of iron, titanium, manganese, chromium, and many other metals were exhaustively investigated at South Kensington. The names of Proto-Iron, Proto-Titanium, etc., were given the metals when in condition to give these enhanced lines. We know now more definitely that what was described as dissociation is loss of an electron, and that when this occurs the enhanced lines appear.

It is scarcely possible to exaggerate the important results which have accrued from the study of enhanced lines. They have contributed greatly to the interpretation of solar and stellar spectra, and have assisted in the sorting out of lines of different elements into series.

In the course of his life Sir Norman Lockyer made observations of no less than eight total eclipses of the sun. His use of a spectroscope without slit led to a

continuous increase of our knowledge of the spectrum of the chromosphere and corona. It has always seemed to me that the most successful of all eclipse expeditions was the one which he led in 1898 and in which he had Prof. Fowler and Dr. Lockyer among his assistants. The differences between the chromospheric and Fraunhofer spectrum were clearly shown as regards the hydrogen and helium lines and the numerous enhanced lines of many metals. In addition the wave length of the principal corona line was determined and some hypotheses as to its origin disposed of finally.

In 1887 Sir Norman Lockyer put forward a scheme of stellar classification in which the stars were arranged according to an ascending and descending scale of temperature. He presented his views in a connected form in his book on "The Meteoritic Hypothesis," published in 1890. In 1902 he published "A Catalogue of 470 Stars classified according to their Chemistry," from material accumulated at South Kensington with an objective prism and studied in the light of laboratory researches. For a long time he stood alone. If we refer to the book of such a learned and judicious astronomer as Newcomb, we find in 1901 ("The Stars," pp. 220-225) that he takes a linear order of development of the stars from the blue to the red, with the sun at about the maximum temperature in the series. Sir Norman could not get over the difficulty that a great orb like Betelgeuse or Antares must be in a widely different condition from a small star like Gr. 24 or Kruger 60. With great freshness of mind and boldness of outlook he framed the meteoritic hypothesis. A comet served as his model for the nebulous beginning of a star. With gradual contraction temperature increased in accordance with Lane's Law till the B stage was reached, after which cooling began, so that in the course of its history a star went twice through the yellow and red stages.

Twenty years later Prof. H. N. Russell, bringing together facts and arguments from many sides, has confirmed Sir Norman's main idea. He has shown that stellar evolution proceeds in the line of increasing density, and that stars of the same temperature may be divided into giants and dwarfs in Prof. Hertzsprung's phrase—in the giants the temperature is increasing and in the dwarfs decreasing.

Sir Norman did not succeed in finding the spectroscopic criteria for giving the sizes of stars. These were found later by Adams and Kohlschütter at Mount Wilson. It is very pleasant to be able to direct attention to the success attending work in this direction now carried on at the Norman Lockyer Observatory.

I cannot conclude without expressing in one sentence the deep obligations which all men of science owe to Sir Norman Lockyer for founding NATURE. One cannot speak too highly of the usefulness of this journal or of the pleasure one takes in reading it each week. Its long continuance is a testimony to the wisdom and foresight of its founder.

The few remarks I have made have dealt very briefly with the main lines of Sir Norman Lockyer's contributions to astronomy—The constitution of the sun—the variety and relationship of terrestrial spectra—stellar evolution. To each of these questions he brought a very fresh mind, and attacked them with courage and imagination. He was a great pioneer of solar and stellar physics. This portrait medallion with its inscription commemorates him in the most suitable place in the observatory which he founded, and which is faithfully carrying on the search prosecuted by him so diligently and successfully into the nature of sun and stars.

#### CONSTITUTION AND WORK OF THE OBSERVATORY

Sir Richard Gregory, in expressing the grateful thanks of the Corporation to the subscribers for their most acceptable gift, said:

As one who had the privilege of being associated with Sir Norman in different capacities for nearly thirty years, as research student, assistant editor of NATURE, and in connexion with the great national organisation—the British Science Guild—created by him in 1905, perhaps I may be permitted to add my tribute to what the Astronomer Royal has said, and to state briefly what this observatory stands for and what we hope it will be in the near future. Sir Norman Lockyer was seventy-six years of age when he started to establish the observatory in 1912, and this in itself is sufficient to show his unbounded zeal and energy. An appeal for funds was made, and some generous supporters came forward, but the means for providing the necessary buildings and equipment, the site itself, and sums for maintenance for several years, were supplied mainly by Sir Norman and Lady Lockyer and Lt.-Col. Frank McClean. The observatory was incorporated in 1916, and its constitution is entirely democratic. Each member of the corporation, whatsoever his contribution, has a single vote, and membership is open to any one approved by the council.

The corporation is unique in its purpose and its constitution. It exists solely to maintain and develop this observatory, not for financial profit but for the gain of knowledge of the heavens. Its foreign members include some of the leading astronomers of the world, and a Research Committee, consisting of Sir Frank Dyson (Astronomer Royal), Prof. Eddington (Cambridge University), Prof. Fowler (Imperial College, South Kensington), and Prof. Turner (Oxford University), advises upon work which may be usefully undertaken. The management and control of the observatory are vested in the council, which is elected by the members.

In these days it may be difficult for some people to realise that a corporation can be formed in which all the services of the council and advisory committees are performed voluntarily, yet such is the case with this observatory corporation. Were it not, indeed, for gifts by members of the corporation, among them the Maharaj Rana of Jhalawar, Mr. Robert Mond, Miss Leigh Browne, Capt. W. N. McClean, and others, as well as for work willingly and freely undertaken, the observatory could not exist. In order to provide, however, for the salaries of the staff and general maintenance of the observatory, even on the present basis, it will be necessary to raise the sum of, at least, fifteen thousand pounds, as the funds hitherto subscribed provide less than one-half the annual income required to meet expenses. We are fortunate in having as director of the observatory Major Lockyer, and it is really wonderful what he manages to accomplish with his assistant, Mr. D. L. Edwards. There is no observatory in the kingdom where more photographs are being taken of the spectra of the stars, from which we learn something of celestial chemistry and are able to classify them from their beginnings as vast attenuated masses up to fervid suns which afterwards cool and condense to the dull redness and darkness of decaying worlds. A generation ago, celestial evolution was believed to proceed entirely on a down grade of temperature from the condition of incandescent gas in a nebula, but Sir Norman Lockyer showed that there is an ascent as well as a descent in stellar temperature, and this key to the classification of the stars is now generally accepted by astronomers.

The large number of photographs of stellar spectra accumulated by Sir Norman Lockyer and largely

taken at this observatory under his direction and that of his son, are now being used to determine the distances of stars by a method due to Prof. W. S. Adams, one of the foreign members of the observatory. The measurements are being made by Mr. D. L. Edwards and Mr. W. B. Rimmer. The Department of Scientific and Industrial Research has made a grant to the latter for the purpose of carrying out a portion of this research while attached to the observatory. The equipment and opportunities here for both education and research in the physics and chemistry of celestial bodies are as full and free as could be desired by the most progressive student or investigator. The endowment of two or three research scholarships tenable at this observatory would be the best service that could be rendered to astronomy, and would certainly result in notable increase of our knowledge of the heavens.

It is remarkable that in the United States funds are provided for observatories and astronomical work, by both university institutions and private benefactions, on a scale far beyond anything available in this country. We once led in astronomy, but America now surpasses us both as regards great observatories and remarkable achievements. Whatever funds are required for buildings, equipment, and workers are readily forthcoming, whereas here benefactions for astronomical work are extremely rare. The Mount Wilson Observatory, where the best astronomical work in the world is now being carried on under the direction of Dr. G. E. Hale, one of our foreign members, cost more than a quarter of a million pounds, and has an annual income exceeding 40,000*l.* It possesses a 100-inch telescope, upon which more than 100,000*l.* has been expended, and it was in connexion with this instrument that nearly two years ago the remarkable achievement was accomplished of measuring the diameters of certain stars, among them the star Antares, which proves to have a diameter of 400 million miles. The Yerkes Observatory, Lick Observatory, Harvard College Observatory, and Lowell Observatory are other examples of great astronomical institutions in the United States which we both admire and envy. The difficulty there is not to obtain funds for astronomical work, but men who will devote their lives to it: here we have plenty of men eager to take up astronomical research but no means to provide them with the necessary instruments and modest salaries to maintain them.

The Norman Lockyer Observatory is the only institution of its kind in this country, and it owes its existence to the generosity of a few people who believe that to place here a temple devoted to the increase of knowledge of the heavens is to provide a mansion in the skies. The county, the nation, and the whole world of science, owe a deep debt of gratitude to the founder and to his supporters, for this fine building reaching out high unto the stars to question them and understand the messages they send us in their beams.

For the means to continue and extend the work so nobly instituted and profitably begun, we appeal to all who are interested in the pursuit of knowledge for its own sake or because of its uplifting influence upon the spirit of man. In faith and hope we ask that this memorable occasion shall mark the beginning of a new and enlarged stage in the history of this observatory, and that the future will see upon this site a centre of modern astronomical research which will maintain the prestige of British science throughout the world and be a worthy memorial to the renowned astronomer who built here this tower from which the heavens can be scanned for intellectual expansion and the enlightenment which the spirit of man is ever seeking as to his destiny.

Col. J. E. H. Balfour, High Sheriff and Lord of the Manor of Sidmouth, expressed on behalf of the county appreciation of Sir Norman's association with Devon and the neighbourhood of Sidmouth. While Sidmouth was famed for its natural advantages of climate and scenery it was little thought that these advantages would be turned to such wonderful and useful purposes. He was glad to know that the confidence felt in the suitability of the site for the observatory had been amply justified, and he deemed it an honour to Sidmouth to possess such an observatory. He expressed the wish that the observatory would have a great future in the advancement of science and knowledge that it deserved.

The Rev. J. S. Cornish recalled that in his memory the grounds of the observatory were formerly one of the wildest and least useful parts of Salcombe Regis. He little thought it possible that from such an expanse of waste would arise an institution that had already become known throughout the scientific world. He referred to the stone of the old sun-worshippers, which still stands near the observatory land where now the modern astronomer reads the truth of the stars with his magnificent telescopes. He hoped that the observatory would become increasingly famous throughout the world, as was the heart's desire of its founder, Sir Norman Lockyer.

Lady Lockyer heartily thanked those who had assembled that day for the unveiling ceremony. Sir Norman looked forward to the observatory being a place where research students could carry out investigations in any branch of spectroscopic research. The provision of a library was essential to house the large collection of books. This would cost about 2000*l.* and they had not that amount of money to spend on it. She hoped a much greater interest would be taken in the work of the observatory, and that the expansion of its activities would not suffer from lack of support. Lady Lockyer expressed the gratitude of Sir Norman's family that his portrait was erected in the observatory which he founded and directed, and which now, by the wish of all the members, bears his name.

### Pioneer Work in Submarine Cable Telegraphy.

THE jubilee celebrations of the Eastern Associated Telegraph Companies are so nearly contemporaneous as to seem to be almost part of the commemoration of the foundation of the Institution of Electrical Engineers, which antedated that of the Company by only a few months. These celebrations carry with them a warning not to lose our sense of historic proportion: they remind us that before a Society of Telegraph Engineers could be established, telegraph engineering had already been well founded, and that the great submarine cable company which now for fifty years has served the Empire and the

whole world with such conspicuous ability and commercial success could scarcely have been the concept of the earlier pioneer days. Only when the art of submarine telegraphy had been amply assured of success could so great a commercial undertaking as that which the Eastern Telegraph Company is now celebrating be initiated.

The following notes on the pioneer work of the cable engineers and others have been drawn freely from the discourse which Sir Charles Bright delivered at the Electrical Engineers' commemoration.

Perhaps it is a little far-fetched to treat quite

seriously the earliest suggestion that electric signals might be sent under the sea. Yet it is worth while to note that so early as 1811 an effort was made to discover a suitable insulating covering for a submarine wire and that the material used was india-rubber. The decisive factor whereby submarine telegraphy became a practical proposition was, however, contributed by Dr. Werner Siemens in 1847 when he laid a telegraph cable in Berlin with wires insulated by gutta-percha. Faraday, as Sir Charles Bright reminds us, was also at the same time directing attention to the insulating properties of this new material. Gutta-percha has never from that day to this had a serious rival for insulation of deep-sea cables.

Not that the pioneers had waited for it! Previously, in June 1845, the brothers Brett, although only small shopkeepers, in the true spirit of the old merchant venturers applied for government sanction to the provision of telegraphic communication between England and France. When the concession came in 1849, gutta-percha had come into its own and most of the cable laid was of copper wire with a half-inch coating of gutta-percha. The need for a special "shore-end" was recognised even then; but it is puzzling to know why a different insulation should have been adopted. Yet we read that "the shore-ends for about 2 miles from each terminus consisted of a No. 16 BWG. conductor covered with cotton soaked in indiarubber solution, the whole being encased in a very thick lead tube." It is scarcely surprising that it failed, but not before, by transmission of a few signals, it had demonstrated the practicability of ocean telegraphy. A "mad freak," a "gigantic swindle," but, like many another failure, a signpost to success. The next year a new concession was secured and the Submarine Telegraph Company was formed, but it was only floated on the capital of a railway engineer (Thomas R. Crampton) and his friends. The resulting cable, not completed until the end of 1851, marked another development of the engineer's art in cable-making. Küper, a colliery engineer, suggested sheathing the insulated wire with iron wires like a colliery pit rope; and so was reached the essential, and till now the final, form of the successful and trustworthy submarine cable.

Perhaps one day some one will write a work on "Government *versus* Enterprise" in the hope that responsible public servants may be taught by their predecessors' failures. In 1850 the Bretts again found that, "although sensible of their perseverance in bringing the submarine telegraph about," the Government could do nothing to help, and so—"landing rights" not having yet been invented—the Bretts proceeded on their own responsibility to span the

Irish Channel. Ultimately success was achieved in 1853, with Charles Tilston Bright (aged 21) in command as engineer to the Magnetic Telegraph Company.

These efforts, however, although they had demonstrated the practicability of submarine telegraphy, had not finished the work of the pioneer—the great unfathomed depths of ocean had yet to be spanned. To put a cable miles deep on the bed of the Atlantic would be impossible, it was said, even if signals could be passed through the enormous length of 2000 miles. Of course pioneers are never very anxious to do anything but the impossible; so J. W. Brett, Cyrus Field (a wealthy American business man who incidentally had discovered, or perhaps invented, "landing rights" for Newfoundland) and Charles Bright (as engineer) projected and with other venturers formed the Atlantic Telegraph Company and secured the required capital in a few days. This was of course only the beginning of the pioneer engineers' work. The British and the United States Governments encouraged and helped the scheme with men-of-war, and at last on August 5, 1858, the shore-end having been duly landed at Newfoundland, the telegraph had bridged the ocean; and the *Times* could say "since the discovery of Columbus nothing has been done in any degree comparable to the vast enlargement which has thus been given to the sphere of human activity." Unfortunately, although the practicability of the scheme had been amply demonstrated and the engineering success was unquestionable, after about two months' work the communication failed—the conductivity of the cable was too low and the power applied to it was too high.

Then followed cables to the east—to Malta, Alexandria and India *via* the Persian Gulf, and it was not until 1865 that any further effort to lay a cable across the Atlantic was projected. In the meantime, Lord Kelvin had perfected his wonderful mirror apparatus, the progenitor of the siphon recorder; closer knowledge of the actual requirements had been secured and improvements in methods of manufacture developed. Also the paying-out and picking-up gear had been largely developed by Henry Clifton, and Brunel's great ship the *Great Eastern* was available to take the large core cable that Bright had succeeded in securing. By the end of 1866 there were two cables working across the Atlantic and the pioneers had about finished their part of the business. The next was routine—and skill combined with knowledge. Other cables followed, east and west; and then in 1872 commenced the great commercial achievements under Sir John Pender, which the Eastern Telegraph Companies are celebrating, after fifty years, with such justifiable pride.

### International Chemistry.

THE International Union of Pure and Applied Chemistry held a successful annual meeting in Lyons on June 27-July 2. This was the third annual meeting and a good deal of time was, as on the former occasions, devoted to the details of organisation and the business of getting such an international body well established. Prof. Moureu has been president for three years and has had a difficult task in framing a policy for the score of nations who are now represented in the Union and in guiding them into harmony in these troublous times. He has achieved his desire, and the Union seems likely to continue for many years and to have an increasing importance. It is intended in the future to pay more attention to the purely scientific side of the subject and to attempt some discussions which will be of permanent value.

The Lyons meeting was well attended, about a hundred and twenty delegates taking part, among whom may be mentioned Messrs. Swarts and Timmermans (Belgium), Billmann (Denmark), Mourelo (Spain), Parsons, Bartow, and Washburn (United States), Grignard, Kestner, Marie, Moureu, and Perrin (France), Pope, Lowry, Hewitt, and Mond (Great Britain), Nasini and Paterno (Italy), Bodtker (Norway), Cohen, Kruyt, and Verkade (Holland), and Votofek (Czecho-Slovakia). Lyons is well provided with suitable buildings for the various meetings and social functions and there are many objects of interest in the vicinity. The commissions on nomenclature, publications, standards, food analysis, industrial hygiene, and international patents continued their work and presented interim reports. To carry out the recommendations of these commissions

requires more money than the International Union can provide, and a finance committee was appointed to allocate such funds as are available to those commissions the needs of which seem to justify the expenditure the most. It will be a case of the survival of the fittest, and the members of the finance committee, Messrs. Fraser (U.S.A.), Bertrand (France), Pomilio (Italy), and Miall (England) are not likely to be very popular with the members of the various commissions.

M. Kestner presided over the commission on international patents, a difficult problem which admits of no speedy solution. He has a plan for dealing with some of the defects of the existing system but proposes no universal panacea for all the inventors' troubles. Those who are interested in this thorny question might well communicate with him or the Société de Chimie Industrielle in Paris.

Interesting papers on purely scientific subjects were read by Profs. Perrin and Vignon.

Owing to the inability of some of the members to visit Lyons at this time the important Committee on the Elements which replaces the old International Committee on Atomic Weights did not meet. It is now meeting or has just met in Paris, and an authoritative list of atomic weights, isotopes, and

other such data should be issued at a suitable interval after that meeting.

The Union elected as president for the ensuing three years Sir William Pope, and as vice-presidents for the same period Profs. Bancroft, Paterno, Billmann, and Votoček. It is probable that two additional vice-presidents will in due course be elected also, a proposal which is necessitated by the growing number of the countries concerned in the Union.

The next meeting will be held in Cambridge in the latter part of next June, and a considerable effort will be made to render this meeting one of real chemical importance. The French, who have been very prominent in the early stages of the Union, have done such good work in very difficult circumstances that it is felt that the English must, to maintain the tradition now that things are becoming a little easier, play their part in a manner which will be worthy of the ancient University which offers its hospitality and of the new president who will direct the proceedings of the meeting.

It is quite likely that the Society of Chemical Industry will hold its annual meeting next year in Cambridge immediately after the meeting of the International Union and a considerable migration of British and foreign chemists may be expected.

### Radio Broadcasting in Great Britain.

DISAPPOINTMENT has been expressed at the delay in introducing radio broadcasting, arrangements for the establishment of which have been under discussion for some time past by the Postmaster-General and manufacturers of radio apparatus. The necessity, however, for the most careful and thorough examination of all aspects of the question is best illustrated by considering the present position of broadcasting in the United States. Radio broadcasting was commenced by the Westinghouse Electric and Manufacturing Co., for the information and entertainment of the public. Their success, however, produced a host of imitators, and broadcasting stations were established indiscriminately, some privately and some publicly owned. Only during the last few weeks has the United States Government taken action to co-ordinate and control indiscriminate transmission from radio-telephonic stations. When two broadcasting stations send out messages at approximately the same wave-length the electrical waves interfere with each other and the listener hears the conversation of two people speaking at the same time. It is not surprising to learn that the absence of a co-ordinating authority in the United States has resulted in a service which is unsatisfactory to the public owing to the lack of general agreement as to hours of operation, wave-lengths employed, and the character of broadcasted matter.

The British Government has wisely and properly decided that broadcasting licences will not be issued until those interested in carrying out this work are agreed on a scheme which will ensure, in the first place, efficiency and continuity of broadcasting, and, in the second place, agreement respecting hours of working, wave-lengths, number and location of stations, etc. Only in this way can confusion be prevented. Furthermore, the Government desires to prevent the broadcasting of advertising matter, in addition to having to safeguard the interests of newspapers and news agencies, Army, Navy, and Air Force work, commercial radio-telegraphy, etc.

We understand that about twenty manufacturers applied to the Postmaster-General for leave to broadcast, and during the preliminary discussions it became evident that the erection, equipment, main-

tenance, and operation of a proper broadcasting station costs approximately 20,000*l.* per annum. A number of manufacturers therefore intimated their desire to abandon the idea of broadcasting, while about six of the strongest electrical concerns in the country interested in radio developments are prepared to continue. The manufacturers appointed a sub-committee to draft a scheme, and this committee reached agreement on all the main features of a broadcasting system for Great Britain. They were, however, unable to put forward an agreed scheme for one company to undertake broadcasting. It is now understood that the manufacturers have divided themselves into two groups, each of which is proceeding to form a broadcasting company, with one or other of which all manufacturers of radio apparatus would be associated. At the same time the Postmaster-General has intimated his willingness to give a licence to each of these companies to operate stations. The two groups between them undertake to establish a sufficient number of stations to serve the whole country. There will probably be one station belonging to each group in London and seven other stations distributed throughout Great Britain, divided between the two groups by mutual arrangement or, if agreement is not reached, by allocation of the Postmaster-General.

There is little doubt that details of working arrangements between these two groups will shortly be settled, and that broadcasting will be established on a basis which will give efficient and continuous service to the public without the hopeless confusion and lack of adequate control evident in the United States.

If each of the above nine stations is to have an annual cost of about 20,000*l.* per annum, the two broadcasting groups have to contemplate an outlay of 180,000*l.* per annum. In order to assist the groups in securing an adequate return for this enormous outlay, it has been suggested to the Postmaster-General that a portion of the licence fees paid by users of receiving sets should be returned to the broadcasting groups. The groups represent between them the whole of the manufacturers of radio apparatus in this country, and their constitution is such that a genuine manufacturer must be admitted if he so

desires. The arrangement, therefore, does not exclude any genuine manufacturer, either now or in future, from playing his part in the business of manufacturing and selling receiving sets, and cannot therefore in any sense be regarded as creating a monopoly. Should the share of the annual licence fee paid to the broadcasting groups provide more money than is necessary to carry on the work, the licence fees could be automatically reduced.

Radio receiving apparatus lends itself particularly to manufacture abroad, in countries on the Continent where the depreciated exchanges make it possible to export receiving sets to this country at a price which would prohibit manufacture here. If this is allowed a promising new industry which will give employment to a very large number of people will be strangled before it has a fighting chance to succeed, and an opportunity of relieving distress arising from unemployment will be lost. Help for this industry, which may have ramifications far more important from the national point of view than the provision of entertainment or even methods of communication, may be given in some way. The Postmaster-General does not propose to license receiving sets unless made by members of one or other of the broadcasting organisations.

It is questionable whether manufacturers will be prepared to risk incurring the heavy expense attached to a broadcasting scheme if conducted in a proper manner, unless some assistance on the lines suggested can be provided. It is also not unreasonable to ask the public to assist in the cost of broadcasting, in view of the likelihood of providing programmes such as the following, which is typical of the best American stations.

"At six o'clock each evening, summary of important news, commercial, general, and sporting, followed at 7 P.M. by special addresses and lectures by business men and women. At 7.30 P.M. a bed-time or nursery story is provided for children, and at 8, for the remainder of the evening, a high-class musical programme comprising vocal and instrumental items or orchestral selections. Time signals are radiophoned at definite hours.

"On Saturdays the musical side of the programme is increased to include afternoon as well as evening performances. On Sundays church and chapel services and sermons are transmitted during morning and evening, with a Bible story for children during the afternoon.

"The lectures and music cover an extraordinarily wide range and appeal to all tastes, while the character of the broadcasted matter is varied and the quality is uniformly high. The tendency is to avoid transmission of gramophone music."

There will be nothing of interest to hear until broadcasting programmes are established, but a number of English stations can be set up very quickly once the preliminary discussions are completed and conditions of working settled, and there is reason to believe that by the autumn the country will be able to enjoy the best broadcasting in the world.

### University and Educational Intelligence.

BANGOR.—Dr. Edward Greenly has been appointed "Special Lecturer" in geology. Dr. Greenly has for the last twenty years been engaged on a detailed study of the geology of Anglesey, and has recently published an account of his researches in a monograph "The Geology of Anglesey" (2 vols.), which has been issued under the auspices of the Geological Survey. For this work, Dr. Greenly received the

Honorary Degree of D.Sc. from the University of Wales. Dr. Greenly is now studying the Carnarvonshire coast. His appointment as "Special Lecturer" will enable him to direct the studies of advanced students who wish to work in this district, which is well suited for geological research.

EDINBURGH.—At the recent graduation ceremonies on July 21, science was represented in the list of Honorary Graduates in Laws by the following: Sir Isaac Bayley Balfour and Sir J. Halliday Croom, recently retired from their respective chairs; Prof. J. B. Farmer of the Imperial College of Science and Technology, London; Sir Thomas Middleton, formerly of the Board of Agriculture; Mr. J. W. Mollison, late Inspector-General of Agriculture in India; M. Roger, Dean of the Faculty of Medicine of the University of Paris; Sir Charles S. Sherrington, Waynflete professor of physiology in the University of Oxford, and Dr. W. Somerville, professor of rural economy in the University of Oxford.

Dr. E. M. Wedderburn, known for his experimental work on seiches and for his services during the war as a meteorologist, has been appointed to the chair of conveyancing in the University.

LONDON.—Dr. J. F. Unstead, head of the geography department, Birkbeck College, has been appointed professor of geography in the University, in respect of the post held by him at Birkbeck College.

MANCHESTER.—The following have been awarded the degree of Doctor of Science: Mr. A. F. Campbell, for theses on (i.) The influence of the introduction of the methyl group into the phenol molecule; (ii.) The separation of phenol, ortho-, meta-, and para-cresols from crude coal tar and carbolic acids; (iii.) A method for the preparation of  $\beta$ -naphthyl-amine; and seven other papers. Mr. J. N. Greenwood, for theses on (i.) The constitution of copper-aluminium alloys; (ii.) Applications of optical pyrometry in steelworks practice; (iii.) Heat flow of steel during ordinary processes of manufacture; and six other papers. Mr. W. A. Harwood, for a memoir on upper air work in India. Mr. J. Holker, for a thesis on the periodic opacity of certain colloids in progressively increasing concentration of electrolytes; and twelve other papers. Mr. J. E. Jones, for theses on (i.) The distribution of energy in air surrounding a vibrating body; (ii.) The velocity distribution function of the stresses in a non-uniform rarefied monatomic gas; (iii.) The kinetic theory of electrical conduction in an ionised monatomic gas; and three other papers. Mr. J. Pearson, for memoirs on (i.) The Holothuriidea of the Indian Ocean; (ii.) Cancer; and a large number of articles and reports on biological work in Ceylon.

A PHYSICIST is required by the Research Association of British Motor and Allied Manufacturers for work as a senior research assistant. Applications are to be made by letter to the Secretary of the Association, 15 Bolton Road, Chiswick, W.4.

The British Silk Research Association, Inc. (Kingsway House, Kingsway, W.C.2), invites applications for the appointment in its laboratory in Leeds of a chemist with research experience and special qualifications in physical chemistry. The latest date for the receipt of applications is August 11.

APPLICATIONS are invited for the position of a plant physiologist in the division of botany of the Department of Agriculture, Union of South Africa. Candidates must possess a University degree and have carried out research work in plant physiology. Applications, with particulars of education, qualifications and experience, etc., all in duplicate, must



reach the Secretary, Office of the High Commissioner for the Union of South Africa, Trafalgar Square, W.C.2, not later than August 30.

A DIRECTOR of fisheries for Bengal is to be appointed shortly by the Ministry of Agriculture and Fisheries for a period of at least three years. Candidates are expected to have a first-class knowledge of marine biology, and practical experience in fishery work. Further particulars may be obtained from the Fisheries Secretary, Ministry of Agriculture and Fisheries, 43 Parliament Street, London, S.W.1, to whom all applications, accompanied by not more than six testimonials, should be addressed by, at latest, August 20.

Two research scholarships in veterinary science, each of the annual value of 200*l.* and tenable for three years, are being offered by the Ministry of Agriculture and Fisheries. The scholarships are open to candidates who have obtained the diploma of the Royal College of Veterinary Surgeons, or who have shown evidence of proficiency in medicine or other relevant branch of science. Applications will be received until August 15 on the prescribed form, of which copies may be obtained from the Ministry at 10 Whitehall Place, S.W.1.

The prospectus for the year 1922-23 of the Technical College, Bradford, contains very complete accounts of the courses of study offered by the College. Diploma courses, which involve full-time attendance for three or four years, are arranged in the departments of civil, mechanical, and electrical engineering, textile industries, chemistry, dyeing, and occasionally in biology. These courses are suitable for students desirous of presenting themselves for the honours examinations of the University of London. There are also special day courses in these departments, and preparation is given for the professional examinations in medicine, dentistry, and pharmacy. Part-time day courses are arranged in various subjects which are suited to the needs of apprentices and others who are unable to devote the whole of their time to study. The prospectus gives particulars of the conditions for the admission of students, and there are also detailed syllabuses of the various courses.

THE Ramsay Memorial Fellowship trustees have made the following awards: Ramsay Fellowship of the value of 300*l.* tenable for one year, but renewable for a second year, to Dr. R. W. Lunt, of the University of Liverpool, and of University College, London, for the continuation of his work at University College, London, on chemical effects of electromagnetic waves over the frequency range,  $10^5$  -  $10^6$  cycles; Glasgow Ramsay Fellowship of 300*l.* to Mr. J. A. Mair, of the University of Glasgow, who will continue his research on the chemistry of the terpenes; a special Fellowship of 300*l.* for one year to Mr. W. Davies, who has already held a Ramsay Fellowship for two sessions and whose work, especially that on the preparation of synthetic reagents from the toluic acids, shows special promise; Danish Ramsay Fellowship to Mr. Kristian Højendahl, of the University of Copenhagen, who will pursue his research in the University of Liverpool; two Swedish Ramsay Fellowships, to Dr. J. O. G. Lublin and Mr. A. W. Bernton; and two Norwegian Ramsay Fellowships to Mr. Dag Nickelsen, who will work at the Imperial College of Science and Technology, and Miss Milda Prytz, who will work at University College, London. A special Ramsay Fellowship of the value of 350*l.*, which was placed at the disposal of the National Research Council of the United States of America, has been awarded to Dr. C. S. Pigott, of Baltimore, who will begin work at University College, London, in October.

## Calendar of Industrial Pioneers.

**August 7, 1834.** Joseph Marie Jacquard died.—A native of Lyons, which he helped to defend against the armies of the Convention in 1793, Jacquard was a weaver by trade. Becoming known for his ingenuity and his attempt to construct lace-making machines, he was employed by Carnot at the Conservatoire des Arts et Métiers, and on December 23, 1801, he patented his well-known loom for weaving figured materials. Though like Arkwright he met with much opposition, Napoleon in 1806 granted him a pension of 6000 francs and a premium on each loom erected.

**August 7, 1913.** Samuel Franklin Cody died.—Accidentally killed when flying at Aldershot, Cody was one of the most enthusiastic of the early fliers and was the designer and constructor of the machines he flew. Born in 1861 in Birdville, Texas, after a somewhat chequered career he gained a reputation by his experiments with kites, and in 1906 was appointed chief instructor in kite-flying to the British Army.

**August 7, 1747.** Martin Triewald died.—A promoter of industrial progress in Sweden, Triewald was born in Stockholm. He spent some years in England as manager of a coal mine at Newcastle, and on his return to his native country introduced the use of the Newcomen atmospheric engine.

**August 8, 1873.** Sir Francis Ronalds died.—One of the pioneers of the electric telegraph, Ronalds was the son of a London merchant. Born in 1788, he was early engaged in scientific pursuits, and in 1816, in the garden of his house in Hammersmith, laid down eight miles of wire through which he sent signals by the aid of a small frictional machine. From 1843 to 1852 he was honorary director of the meteorological observatory at Kew.

**August 10, 1896.** Otto Lilienthal died.—After achieving success as an engineer and manufacturer, Lilienthal in 1889 began his experiments in flight. With machines of his own construction he made many long gliding flights from the top of an artificial mound nearly 100 feet high at Lichterfelde, and it was while pursuing these experiments that he met with the accident from which he died.

**August 12, 1848.** George Stephenson died.—Recognised as the father of our railway system, and as the chief pioneer of the locomotive, Stephenson built his first successful locomotive in 1814 while engine wright at Killingworth Colliery. For the Stockton and Darlington Railway he constructed and drove the *Locomotion* with which the line was opened in 1825, and four years later achieved a notable success with the *Rocket* constructed for the Liverpool and Manchester Railway. Stephenson was engineer to both of these lines and was afterwards engineer also to the London and Birmingham, the Manchester and Leeds, the Manchester and Birmingham and other important railways. He was the first president of the Institution of Mechanical Engineers, founded in 1847.

**August 13, 1897.** Sir Isaac Holden died.—Born near Paisley in 1807, Holden at the age of ten began work in a cotton mill. From a shawl weaver he became a school teacher and then a book-keeper for a Glasgow worsted firm. Turning his attention to invention, with Lister (afterwards Lord Masham) in 1847 he took out a patent for combing and preparing genappe yarn and founded a factory at St. Denis, Paris. He afterwards concentrated his business at Bradford, where it became the largest woolcombing concern in the world. E. C. S.

## Societies and Academies.

## PARIS.

Academy of Sciences, July 3.—M. Emile Bertin in the chair.—The president announced the death of Prince Albert of Monaco, foreign associate of the Academy.—P. A. Dangeard: The structure of the cell in the Iris. In a recent communication the author has given a detailed description of the plastidome and spherome in the leaves of *Iris germanica*: this is supplemented in the present paper by similar details for the same formations in the tissues, petals, sepals, stamens, ovary and ovules. The plastidome and spherome are independent formations and have an existence as general as the nucleus in the plant cell.—André Blondel: The unsymmetrical electric arc between carbon and metals.—M. Albert Recoura was elected correspondent for the section of Chemistry in the place of the late M. Ernest Solvay.—The Permanent Secretary announced the death of M. Otto Lehmann, correspondent for the section of Mineralogy.—Armand Cahen: Singular solutions of differential equations of the first order.—Mieczislas Biernacki: The displacement of the zeros of integral functions by derivation.—R. Jarry-Desloges: Contribution to the study of the surface of planets. The systematic observation of the planetary surfaces, especially of Mars, commenced in 1907 at Revard, have been continued in May and June of this year at Sétif, with the 37 cm. and 26 cm. refractors. The decoloration of certain dark areas in the southern hemisphere of Mars, observed in 1909 at Revard, has been seen again this year.—Jules Baillaud and Mlles. Bonnet, Clavier, and Lhomme: Distribution of stars in the Paris zone of the astrophotographic catalogue.—Axel Lindh: The absorption spectrum of sulphur for the X-rays. An examination of sulphur compounds grouped according to the valency of the sulphur. As in the case of chlorine previously studied, the limits of the K absorption for sulphur are displaced towards the shortest wave-lengths for the higher valencies.—Albert Portevin: The thermal treatment of cast pieces, and especially of cast projectiles. Thermal treatment produces porosity in the metal.—Roger G. Bousso: The limit of inflammability of the vapours of the alcohol-petrol system and of a triple system containing as base alcohol and petrol.—C. Matignon and M. Fréjaques: The transformation of gypsum into ammonium sulphate. Calcium sulphate was stirred with concentrated ammonium carbonate solution in approximately equimolecular proportions. Equilibrium was reached after five hours, about 96 per cent. being converted into ammonium sulphate.—Albert Granger and Pierre Brémont: The chemical composition of rock, supposed to be kaolin, from Djebel Debar, Algeria. This is formed of halloysite, associated with a hydrated aluminium silicate containing combined sulphuric acid.—Paul Thiéry: The upper Bajocian of Lorraine.—G. Denizot: The last variations of the marine level on the coasts of Basse-Provence.—P. Bugnon: The basinge acceleration in the hypocotyl.—G. Nicolas: A new host of Phyllosiphon. This parasite was found on *Arum italicum* near Toulouse. This resembles *P. Arisari*, and if not belonging to a different species, constitutes a different biological strain, since although *Arisarum vulgare*, carrying *P. Arisari*, grows in the neighbourhood of *Arum italicum* in Algeria, the latter plant has not been found attacked by the parasite.—

Pierre Lesage: Experiments on the movement of liquids in cell masses.—Jacques de Vilmorin and Cazaubon: The catalase of seeds. The presence of catalase cannot be taken in all species as a proof of the vitality of the seed.—Marc Romieu and Fernand Obaton: Comparative spectroscopic study of the green pigment of the Chetoptera and the chlorophyll of the green alga, *Uha lactuca*. The chetopterin is regarded as a pigment of extrinsic origin, and is a modified chlorophyll.—Mme. Danysz-Michel and W. Koskowski: Study of some digestive functions in normal pigeons, fed with polished rice or kept without food. Comparative experiments made with pigeons on four different diets: normal diet, no food, polished rice only with and without daily injection of histamine. From the examination of the gastric juice and intestinal contents it is concluded that the observed facts can be explained without assuming the intervention of a vitamin.—J. Athanasü: Nerve motor energy: electromyograms.—L. Garrelon, D. Santenoise, and R. Thuillat: The action of peptonic shock on the vago-sympathetic nervous system.—P. Wintrebert: The first manifestations of nervous co-ordination in the body movements of *Scylliorhinus canicula*—Pierre Girard: Remarks on a note of M. L. Lapique on the mechanism of the exchanges between the cell and the surrounding medium.—W. R. Thompson: The theory of the action of entomophagous parasites. Increase in the proportion of hosts carrying parasites in cycle parasitism.—S. Metalnikov: An epizootic disease in the caterpillars of *Galleria mellonella*.—R. Cambier and E. Aubel: The culture of bacteria in a medium of definite chemical composition, with pyruvic acid as a base. The degradation of pyruvic acid. In these cultures the only source of carbon is sodium pyruvate. Three bacilli could be grown on this medium, the pyocyanic bacillus, Flügge's fluorescent bacillus, and the coli bacillus. Acetic, lactic, and glycollic acids were isolated from the cultures.

## Official Publications Received.

Records of the Indian Museum. Vol. 24, Part 2, June: Notes on Crustacea Decapoda in the Indian Museum. By Stanley Kemp, XV. P. 201-224. Pp. 113-288+plates 3-9. (Calcutta: Zoological Survey of India.) 2 rupees.

The Institution of Civil Engineers. Engineering Abstracts prepared from the Current Periodical Literature of Engineering and Applied Science, published outside the United Kingdom. Edited by W. F. Spear. New series, No. 12, July. Pp. 228. (London: The Institution of Civil Engineers.)

Bureau of Education, India. Pamphlet No. 12: Science Teaching in England. By H. Banister. Pp. v+28+ii. (Calcutta: Government Printing Office.) 7 annas.

Ministry of Agriculture and Fisheries: Intelligence Department. Report on the Work of the Intelligence Department of the Ministry for the Two Years 1919-1921. Pp. 198. (London: H.M. Stationery Office.) 5s. net.

Ministry of Public Works, Egypt. Report on Investigations into the Improvement of River Discharge Measurements. By E. B. H. Wade. Part 2. (Physical Department Paper No. 6.) Pp. 12+14 plates. (Cairo: Government Publications Office.) P.T. 5.

Ministry of Public Works, Egypt: Physical Department. Meteorological Report for the Year 1917. Pp. x+118. (Cairo: Government Publications Office.) P.T. 30.

The Mauritius Almanac and Commercial Handbook for 1922 (with which is included an Appendix on Seychelles). Compiled by A. Walker. Pp. iii+2+ xviii+ viii+ A66+ B57+ C67+ D64+ E30+ F80+ 15. (Port Louis, Mauritius: General Printing and Stationery Co. Ltd.) 10 rupees.

Loughborough Collee, Leicestershire. Calendar, Session 1922-23. Pp. xx+216. (Loughborough.)

Forestry Commission. Second Annual Report of the Forestry Commissioners: Year ending September 30th, 1921. Pp. 44. (London: H.M. Stationery Office.) 9d. net.

Report for 1921 on the Lancashire Sea-Fisheries Laboratory at the University of Liverpool and the Sea-Fishery at Picl. Edited by Prof. J. Johnstone. No. 30. Pp. 237+13. (Liverpool.)

# NATURE

Stamp: 25 1/2 National Mus

A WEEKLY ILLUSTRATED JOURNAL OF SCIENCE.

*"To the solid ground  
Of Nature trusts the mind which builds for aye."*—WORDSWORTH.

No. 2754, VOL. 110] SATURDAY, AUGUST 12, 1922 [PRICE TWO SHILLINGS

Registered as a Newspaper at the General Post Office.]

[All Rights Reserved.]

## OPTICAL PROJECTION APPARATUS

for all classes of

EDUCATIONAL WORK.

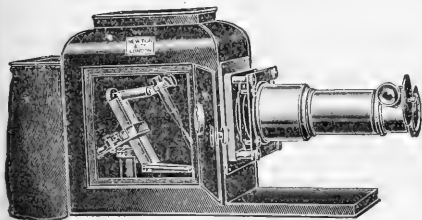

*Catalogue on application.*

**NEWTON & CO.,**

*Opticians to H.M. the King.*

72 WIGMORE STREET, LONDON, W.1.

## CHEMICALS

Analytical, Technical and A.R.

REC'D. TRADE MARK **APPARATUS**

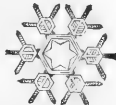

A SNOW CRYSTAL

Balances  
**BENCHES**

Fume Chambers, etc.,

for  
**Chemical, Physical, and  
Technical Laboratories.**

*Price Lists and Estimates on Application.*

**REYNOLDS & BRANSON, LTD.,**

Contractors to the War Office, Admiralty and  
Egyptian Government, &c.

14 COMMERCIAL STREET, LEEDS.

**BAIRD & TATLOCK LONDON LTD.**

SCIENTIFIC INSTRUMENT MANUFACTURERS  
and LABORATORY FURNISHERS.

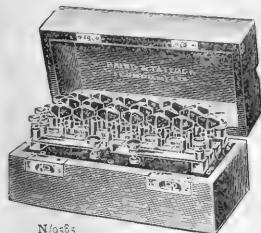

N/19c85  
RESISTANCE BOX

Physical  
Apparatus  
for  
Schools  
and  
Colleges.

**14-15 CROSS STREET, HATTON GARDEN, LONDON, E.C.1.**

## BAROGRAPHS

Four rubber feet to the base  
—a self-adjusting pen arm—  
a supporting rod to the cover—  
these are some of the refinements  
on our Recording Barometers.  
Write for price list "B.3."

**NEGRETTI & ZAMBRA**  
38, HOLBORN VIADUCT, E.C.1.  
LONDON.

FACTORY : HALF-MOON  
WORKS, BARNSBURY.

## UNIVERSITY OF ST. ANDREWS.

Chancellor—Field Marshal The Right Honourable THE EARL HAIG OF BEMERSYDE, K.T., G.C.B., O.M., G.C.V.O., K.C.I.E., LL.D.

Rector—SIR JAMES MATTHEW BARRIE, Bart., O.M., M.A., LL.D.

Principal and Vice-Chancellor—JAMES COLQUHOUN IRVINE, C.B.E., Ph.D., D.Sc., LL.D., F.R.S.

### OPENING OF SESSION 1922-1923—WEDNESDAY, OCTOBER 11, 1922.

Preliminary Examinations begin Friday, September 15. Schedules and other information may be had from the SECRETARY, University, St. Andrews.

Before beginning a course of study for Graduation every student must obtain a certificate showing that he has satisfied the Scottish Universities Entrance Board of his fitness to enter upon the curriculum.

Courses of instruction open to men and women students are provided towards Graduation in Arts, Science, Medicine, and Divinity.

The University grants a Diploma in Public Health, a Diploma in Dental Surgery, a Diploma (for Graduates) and a Certificate (for other qualified students) in Social Study and Training.

### ARTS, SCIENCE, AND MEDICINE, UNITED COLLEGE, ST. ANDREWS.

The Classes include Latin, Greek, English, French, German, Hebrew, Logic, Moral Philosophy, Political Economy, Education, Mathematics, Applied Mathematics, Natural Philosophy, Chemistry, Zoology, Botany, Geology, Modern History, Medieval History, Economic History, Anatomy, Physiology.

ENTRANCE BURSARIES, open to competition annually in June:

For Men—Twelve to fourteen Bursaries, £50 to £100 per annum, tenable for three or four years.

For Women—Six Medical Bursaries, £40 to £50, tenable for two years.

For Men or Women—Six or eight Bursaries from £50 to £100, for three, four or five years. (Other Bursaries are open to competition at intervals of three or four years; and eight or ten Presentation or Preference Bursaries, in the gift of patrons, ranging from about £40 to £2100, are annually presented.)

SECOND YEAR BURSARIES.—Two or three Bursaries of £50 to £40 for two years (men or women), and one or two Bursaries of £30 to £16 for two or three years, for men students, awarded annually by competition.

FOURTH AND FIFTH YEAR BURSARIES AND GRANTS.—Eight or nine Bursaries and Grants from £40 to £15, tenable for one year, are annually awarded to students of the fourth or fifth year studying for Honours Degrees.

SCHOLARSHIPS, etc.—Seventeen or eighteen Scholarships, Bursaries, and Grants for Advanced or Research Students, £80 to £200, tenable for one year, awarded annually.

Particulars in a free pamphlet may be had from the SECRETARY, University, St. Andrews.

### ARTS, SCIENCE, AND MEDICINE, UNIVERSITY COLLEGE, DUNDEE.

The Classes include Mathematics, Applied Mathematics, Physics, Chemistry, Engineering and Drawing, Zoology, Botany, Anatomy, Physiology, Electrical Engineering, Geology, Latin, English, French, German, Logic, Education, Modern History and Scots Law.

ENTRANCE BURSARIES, open to competition annually in June.—Nine Bursaries, £15 each, tenable for one year, open to men or women students in any Faculty, and one of £15 for Engineering students.

SECOND AND THIRD YEAR BURSARIES.—Ten Bursaries, £15 to £20 each, tenable for one year.

SCHOLARSHIPS, etc.—Eight Bursaries of £15 to £20 for Advanced Students and several Scholarships for Graduates undertaking Research work.

Particulars on application to SECRETARY, University College, Dundee.

### CONJOINT MEDICAL SCHOOL, DUNDEE.

The Classes include Pharmacology and Therapeutics, Pathology, Surgery, Medicine, Midwifery, Forensic Medicine, Public Health, Ophthalmology, Mental Diseases, Clinical Surgery, Medicine and Midwifery, Diseases of the Ear, Nose and Throat, Diseases of Children, Diseases of the Skin, Fevers, Anaesthetics, Bacteriology, Courses for Diplomas in Public Health and Dentistry. (The first two years of Medical study are provided for either in the United College, St. Andrews, or University College, Dundee.)

The following free pamphlets, "Graduation in Arts," "Graduation in Science," "Graduation in Medicine," "Handbook of Advanced Study and Research and Higher Degrees," "Diploma in Dental Surgery," may be had from the SECRETARY, University, St. Andrews, or the SECRETARY, University College, Dundee.

### DIVINITY, ST. MARY'S COLLEGE, ST. ANDREWS.

The College will open on Wednesday, October 11. The Examination for Bursaries begins on Friday, October 13. Intimation of candidature is not necessary.

A Scholarship of £160 tenable for one year may be awarded biennially to a graduate in Divinity, for advanced study or research.

A free pamphlet will be supplied by the Secretary of the University.

### RESIDENCE HALLS.

Residence Halls for Men and for Women Students at St. Andrews. Particulars may be had from the SECRETARY, The University, St. Andrews.

Residence Hall for Women Students at Dundee. Particulars may be had from the SECRETARY, University College, Dundee.

ANDREW BENNETT,  
Secretary and Registrar.

The University, St. Andrews,  
August 1922.

## EAST LONDON COLLEGE (UNIVERSITY OF LONDON),

MILE END ROAD, E.1.

PASS AND HONOURS COURSES IN THE  
FACULTIES OF ARTS,  
SCIENCE AND ENGINEERING.

FIRST YEAR MEDICAL COURSE.  
POST GRADUATE AND RESEARCH WORK.

Fees—Twenty Guineas a year.

EVENING COURSES, M.A. FRENCH, M.A. & M.Sc.  
MATHEMATICS.  
RESEARCH WORK IN EXPERIMENTAL SUBJECTS.

Fees from Two Guineas a session.

SESSION COMMENCES OCTOBER 2.

## TECHNICAL COLLEGE, BRADFORD.

### Day Courses.

Full-time (Day) Courses, extending over three or four years, and leading to the Diploma of the College, are arranged in the following departments:—

TEXTILE INDUSTRIES. MECHANICAL ENGINEERING.  
CHEMISTRY. CIVIL ENGINEERING.  
DYEING. ELECTRICAL ENGINEERING.  
BIOLOGY.

Special facilities are available for Advanced Study and Research.

### Evening Courses.

Part-time (Evening) Courses are also arranged, on the successful completion of which students are awarded Senior and Advanced Course Certificates.

Further particulars and prospectuses may be obtained on application to THE PRINCIPAL, TECHNICAL COLLEGE, BRADFORD.

## UNIVERSITY COLLEGE OF SWANSEA.

(A CONSTITUENT COLLEGE OF THE UNIVERSITY  
OF WALES.)

Principal—T. FRANKLIN SIBLY, D.Sc., F.G.S.

The Third Session will open on October 2, 1922.

Courses of study are provided for:

- Degrees of the University of Wales in Arts, in Pure Science, and in Applied Science (Metallurgy and Engineering);
- Diplomas of the College in Metallurgy and in Engineering;
- The training of Teachers for Elementary and Secondary Schools;
- The first Medical Examination of the University of Wales and of other Examining Bodies.

Persons who are not desirous of studying for degrees or diplomas may attend selected College Classes, provided they satisfy the Authorities of the College that they are qualified to benefit by such classes.

Entrance Scholarships will be offered for competition in September 1922. Particulars concerning admission to the College, and of the Entrance Scholarships, may be obtained from the undersigned.

EDWIN DREW, Registrar.

University College,  
Singleton Park, Swansea.

## NORTHAMPTON POLYTECHNIC INSTITUTE.

280 ST. JOHN STREET, LONDON, E.C.1.

The Governing Body invites applications for the post of full-time LECTURER and DEMONSTRATOR in the TECHNICAL CHEMISTRY DEPARTMENT, in which the subjects of instruction include Electro Metallurgy, Engineering Chemistry and Metallurgy. Salary on the Barnham scale. Full particulars and forms of application may be obtained from R. MULLINEUX WALMSLEY, D.Sc., Principal,



SATURDAY, AUGUST 12, 1922.

## CONTENTS.

	PAGE
Universities of Oxford and Cambridge Bill	201
Paracelsus. By Sir T. E. Thorpe, C.B., F.R.S.	202
The History of British Agriculture. By Sir E. J. Russell, F.R.S.	204
Ore Deposits. By Prof. H. Louis	205
The Living Soil	206
The Presentation of Thermodynamics	207
Dialectic. By Prof. H. Wildon Carr	208
The Methods of Ecological Investigation. By Dr. E. J. Salisbury	208
Avian Minstrelsy	209
Our Bookshelf	210
Letters to the Editor:—	
The Cause of Rickets.—Sir W. M. Bayliss, F.R.S. ; The Writer of the Article	212
The Phenomena and Conditions of Sex-change in the Oyster ( <i>O. edulis</i> ) and <i>Crepidula</i> .—Dr. J. H. Orton	212
Wegener's Displacement Theory.—E. R. Røe- Thompson	214
The Elliptic Logarithmic Spiral—H. S. Rowell	214
Pairing and Parthenogenesis in Saw-flies.—A. D. Peacock	215
Some Significant Relations in the Quantum Theory of Spectra.—Satyendra Ray	215
Extraction of Radiolaria from Oozes.—H. L. Thomas; Arthur Earland	216
An Attempt to Influence the Rate of Radioactive Disintegration by Use of Penetrating Radiation.— Dr. G. Hevesy	216
Black Coral. By Prof. Sydney J. Hickson, F.R.S.	217
The Determination of Stellar Distances. ( <i>With     diagram.</i> ) By Dr. William J. S. Lockyer	219
Short-wave Directional Wireless Telegraph. By C. S. Franklin	220
Obituary:—	
Prof. W. Wislicenus. By J. F. T.	223
Dr. A. G. Mayor	224
Dr. Alexander Graham Bell. By A. R.	225
Current Topics and Events	226
Research Items	228
The "Immured Standards" in the House of Commons	230
The International Research Council	230
The Philosophical Congress at Manchester	231
The Congress of the Royal Sanitary Institute	232
Pharmaceutical Education and Research	233
University and Educational Intelligence	233
Calendar of Industrial Pioneers	234
Societies and Academies	235
Official Publications Received	236

Editorial and Publishing Offices:

MACMILLAN &amp; CO., LTD.,

ST. MARTIN'S STREET, LONDON, W.C.2.

Advertisements and business letters should be  
addressed to the Publishers.

Editorial communications to the Editor.

Telegraphic Address: PHUSIS, LONDON.  
Telephone Number: GERRARD 8830.

## Universities of Oxford and Cambridge Bill.

WHEN some three years ago the Universities of Oxford and Cambridge applied to Parliament for an annual grant to meet recurring expenses it was obvious that such aid could be given only after due inquiry. Accordingly a Royal Commission was appointed on November 14, 1919, "to enquire into the financial resources of the Universities and of the Colleges and Halls therein, into the administration and application of those resources, into the government of the Universities, and into the relations of the Colleges and Halls to the Universities and to each other." On March 24 of the present year the report of this commission was published, and as a direct result we have the Bill which was introduced by Mr. Fisher, president of the Board of Education, into the House of Commons on July 24.

The Bill is short, consisting of ten sections, with a schedule embodying certain provisions of the Universities of Oxford and Cambridge Act, 1877, adapted for present purposes. Two bodies of commissioners are to be set up, styled respectively "The University of Oxford Commissioners" and "The University of Cambridge Commissioners." The commissioners are named and comprise men representative of the varied aspects and interests of university life. Their tenure of office is temporary and will normally expire at the end of the year 1924, but may on the application of the commissioners themselves be continued by His Majesty in Council for other two years. From and after January 1, 1924, these commissioners will "make statutes and regulations for the University, its colleges and halls, and any emoluments, endowments, trusts, foundations, gifts, offices, or institutions in or connected with the University in general accordance with the recommendations contained in the Report of the Royal Commission, but with such modifications as may, after the consideration of any representations made to them, appear to them expedient."

After the termination of the powers of the commissioners the universities and colleges will again assume their own government, but notice of any proposed statute for a college must be given to the university before it is submitted to His Majesty in Council, and any college statute which affects the university may not be altered without the consent of the university. Again, except with the consent of the trustees or governing body, no trust may be altered "unless fifty years have elapsed since the date on which the instrument creating the trust came into operation." This, however, will not operate against increasing the endowment of any emolument. Further, the contributions of the colleges to university purposes must be assessed in

the first place with regard to the needs of the colleges themselves.

The schedule deals with such questions as the interim powers of the universities and colleges; the provision that the commissioners in framing statutes "shall have regard to the interests of education, religion, learning, and research; the election of college representatives as commissioners; and procedure generally and other matters of detail.

Obviously the Bill must be read in the light of the Report. The institution of two bodies of commissioners is the result of a recommendation in it "that a Statutory Commission should be set up to carry out the changes recommended," and the powers of these two bodies are defined, except in special circumstances, by it. As we have remarked in a previous article in these columns the Report is distinctly conservative. Similarly, the Bill, for example in its provision for dealing with trusts and endowments, shows clearly that there is no intention of making sweeping changes. The new commissioners hold office for a season; the suspension of the autonomy of the universities is merely temporary.

The new bodies have no easy task before them. The problems will demand knowledge, skill, and tact. The question of the reform of the government of the university requires delicate handling. The colleges must be brought into closer relationship with the university. The teaching will have to be reorganised and co-ordinated, and proper provision made for research and advanced work. Fellowships, scholarships, extramural education, cost of living in colleges, non-collegiate students, and entrance examinations are some of the questions to be dealt with. In addition, there are the twin problems of salaries and pensions. Here it may be expected there will be difficulties. Notwithstanding all that has been done in recent years in the modern universities these are problems still unsolved there. The question is not an easy one. For the Cambridge Commission there is the further question of the position of women in the university.

The projected reforms can be effected only by a large increase in the income of the two universities. The Report recommends an annual Parliamentary grant of 100,000*l.* to each university. Such a sum is none too great for carrying into effect its financial proposals. At present the grant is 30,000*l.* to each, and doubtless a further instalment in the immediate future is contemplated. This raises the important question as to whether or not Oxford and Cambridge should have separate and individual consideration in the matter of State aid apart from the modern universities. In some respects it is right and proper that separate and individual consideration should be given to these ancient

institutions, particularly if due respect is to be paid to the conservation of the best of their traditions. But the case is not on all fours where finance is concerned. Until recently the modern universities had been treated somewhat scurvily by the State, and even now they receive only 1,200,000*l.* of an annual Parliamentary grant for allocation among something like sixty institutions. The largest individual grant for the year 1921-2—that received by the Imperial College of Science and Technology—amounts to 67,500*l.*, a sum in our opinion quite inadequate for the expansion and development of an institution of this standing. Moreover, when the amounts allotted to the other institutions of university rank are considered in detail, it is clear that a sum of 200,000*l.* for Oxford and Cambridge is quite out of proportion. The modern universities are not receiving the financial help from the State to which they are entitled, and, in particular, at the very time when Oxford and Cambridge are receiving for the first time an annual grant of 60,000*l.*, they are being deprived of an annual grant of 300,000*l.* This withdrawal cannot be justified. In point of fact the financial difficulties of the modern universities are equally as great as, if not greater than, those of the two older universities.

The question of Parliamentary grants to our universities should be considered as a whole and not piecemeal. In the light of seemingly contradictory statements made in public regarding State aid given to the modern universities it would appear that the whole question should be discussed in Parliament. It is not true, except as a mere technicality, to say that the annual grant to the modern universities will remain at its present level. Any one who takes this statement at its face value will have a rude awakening in the coming financial year. In our opinion, in such circumstances, it would be a mistake to consider the financial needs of Oxford and Cambridge apart from those of the modern universities. The position of the whole of the universities in the United Kingdom should be considered together, and not simply the position of two of them however ancient and honourable their traditions.

### Paracelsus.

*Theophrastus Bombastus von Hohenheim, called Paracelsus: His Personality and Influence as Physician, Chemist, and Reformer.* By Prof. J. M. Stillman. Pp. viii + 184. (Chicago and London: The Open Court Publishing Co., 1920.) 10s. net.

AS is well known, it is the customary lot of revolutionaries, whether in politics, religion, literature, or science, or indeed in any department of intellectual activity, to be both vilified and extolled, and the

praise and the blame are usually administered in very unequal measure, and with no due regard to the intrinsic merits of the recipient. The common instinct of mankind is to oppose change, and he who sets himself athwart the general tendency to consider whatever is right is certain to reap abuse for his pains, and to have his motives, however well meant, misrepresented and traduced. History shows that most reformers are in advance of their age. It is rarely that they hit what is mistakenly called the psychological moment—that is, when the world is ripe for the change they advocate, and willing and even eager to see it effected. In this exceptional case the reformer is extolled, his service universally acclaimed, and his immediate fame assured. The pioneer who has to face the *vis inertiae* of his age may, and usually does, go down to his grave “unwept, unhonoured, and unsung.” It is only when the fermenting leaven he has laboured to introduce has, it may be after many years, produced its effect, that his effort is recognised and its results appreciated.

Such was the fate of him who is the subject of the work under notice. No man of his epoch was so systematically and so consistently disparaged, abused, and reviled as Theophrastus von Hohenheim, commonly called Paracelsus. His true vocation was that of a medical practitioner, and the head and front of his offending was that he should have striven to enlarge the scope of the medical system of his time—not simply by opposing the time-honoured doctrine of Hippocrates and Galen, as authorised by all the medical faculties of the period in every University of Europe—but by seeking to graft on to it newer conceptions and a wider and more rational scheme of therapeutics.

Paracelsus is frequently regarded as a chemist, and he certainly has his place in the history of chemistry. But he made no cardinal discovery in that science, and his name is not associated with any process or apparatus in operative chemistry. He wrote no treatise exclusively concerned with chemistry. He led a restless wandering existence, travelling, according to his own account, over nearly the whole known world, picking up and mentally storing the medical *arcana* of the various countries he traversed.

During the forty-eight troubled years of his chequered life Paracelsus certainly acquired a considerable knowledge of the chemical arts of his time; he writes familiarly of certain chemical processes, and shows acquaintance with the properties and uses of a fairly wide range of manufactured products. His great service to chemistry was that he was among the earliest to point out that the work of the professed chemists of his epoch was on wholly wrong lines. The ostensible objects of alchemy were illusory. In con-

ceiving the possibility of transmutation the alchemists were imagining a vain thing. The true and proper function of the chemist was to serve humanity by preparing and studying the properties of substances of natural and factitious origin with a view of applying them in the treatment and cure of disease.

By thus creating the school of iatro-chemistry Paracelsus enlarged greatly the field of chemistry and extended enormously the scope of its operations. But, strictly speaking, Paracelsus only reverted thereby to the practice of the Arabian followers of Galen—Avicenna, Averrhoës, and their immediate followers—who taught that chemistry was the true hand-maiden of medicine. Their precepts had been misinterpreted and corrupted by a succession of commentators—mostly scholastics—who had imported into their teaching a leaven of mysticism and occultism altogether foreign to the spirit of Galen. Erasmus said of the medical system of his time that the whole art as they practised it was but an incorporated compound of craft and imposture.

The reform of medicine was part of the general movement of the Renaissance, and Paracelsus was as much a product of the period as Leonardo da Vinci, Copernicus, Thomas More, Luther, Vesalius, and the other progenitors of that great awakening. He created not only a new departure in chemistry, but he infused a new spirit into medical teaching and practice, and his reward was to suffer the slings and arrows of outrageous fortune in obloquy, poverty, and occasional starvation. He was fighting against the *Zunftgeist* of his age, against powerful corporations and strongly entrenched vested interests. Although he fell in the unequal struggle he was not beaten, for the spirit he invoked lived after him and eventually triumphed.

Paracelsus was a highly complex character—a strange compound of genius and folly, of ill-regulated life and unstable habits. It is this complexity of nature which is doubtless at the basis of the very divergent estimates which his various biographers have formed of him. He had all the defects of his qualities, and to a great extent he brought his misfortunes upon himself. He was of a rash, unbalanced disposition, impetuous, impatient of contradiction, a hard-hitter, and prone to intemperate language. Of course, he was stigmatised as a quack and a charlatan, and it must be admitted there were incidents in his career which afforded ground for the imputation. He seems to have treated the reproach with a contemptuous indifference which afforded no sufficient answer to his adversaries and no real satisfaction to his few followers and friends.

In spite of much that has been written concerning him Paracelsus remains an enigma, and his memory still suffers from the obloquy which was heaped upon

him during his life. Of late years there has been a tendency to seek to do him fuller justice and to put a more liberal and more kindly interpretation upon his conduct and actions, and to place him in what is to be regarded as his true relation to his epoch. Prof. Stillman's book is the latest attempt at his rehabilitation. It is a scholarly contribution to a subject which has still its perplexities and difficulties. The story of his life is here told without bias, dispassionately, and in the light of all available information, and the result is an eminently readable monograph written in the true spirit of history.

T. E. THORPE.

### The History of British Agriculture.

- (1) *English Farming: Past and Present.* By the Rt. Hon. Lord Ernle. Third edition. Pp. xvi + 504. (London: Longmans, Green and Co., 1922.) 12s. 6d. net.
- (2) *A Short History of British Agriculture.* By John Orr. Pp. 96. (London: Oxford University Press, 1922.) 2s. 6d. net.

(1) THE story of British agriculture is for the greater part of its course the story of the life of the ordinary Briton, for until the industrial and commercial era began a century ago the country was in the main agricultural. Several histories have appeared, but none is more attractive than the volume written by Lord Ernle, which has now reached its third edition. There are few records of actual farming prior to the Norman invasion, and the account here given begins practically in the thirteenth century, though there is no reason to suppose that any great change had been brought about in agricultural methods for a long while previously. From that time onwards, however, the story is continuous, though it has had to be pieced together from manorial records, old country sayings, illuminated MSS., and many other sources. Lord Ernle has done his work remarkably well, and he traces with great clearness the changes from the old open field system, through the enclosures of the sixteenth, seventeenth, and eighteenth centuries, to the great changes introduced in the nineteenth century, and finally to our own times.

The edition before us differs from the previous one in that it contains a chapter on war farming in 1914-1918. This was an essay in State control, and the measure of its unpopularity in the countryside was seen in the almost savage joy with which the wholesale retrenchment of the numerous inspecting officials after the war was hailed, and in the irresistible demand for the removal of all restrictions on freedom of cropping and of farm management. Whatever the urban

voter may elect to bear in the way of State control of industry, it is perfectly certain that the countryman will have none of it: he is an incorrigible individualist.

Space does not allow of an adequate quotation from the account of the history of those eventful days. Lord Ernle has the double advantage of inside knowledge and of freedom from any restriction in relating the course of events, and he tells the story vividly. The real agricultural difficulty began in 1917, after the harvest of 1916. The Board of Agriculture had foreseen this and had prepared a scheme, but the Cabinet had not put it into operation. The winter 1916-17 was very unfavourable to the agriculturist; the supply of men, of feeding-stuffs and of fertilisers was short, and was diminishing, and farmers generally were losing heart. State control became imperative. The method adopted was probably as good as could be devised, and very full powers were given to the large body of experts brought in for the purpose. In spite of all its disadvantages and the increasing difficulties in regard to labour and materials, the system was successful in producing certain items of human food, as the following table proves:

Crops.	1918.	1916.	1904-13.	Increase.		Percentage of Increase.	
				Over 1916.	Over 1904-13.	Over 1916.	Over 1904-13.
(In Thousands of Quarters.)						%	%
Wheat . . .	10,534	6,835	6,653	3,699	3,881	54	38
Barley . . .	6,085	5,181	6,212	904	-127	17	-2
Oats . . . .	14,336	10,411	10,572	3,925	3,764	38	36
Mixed Corn . .	4620	..	..	620	620	..	..
Beans and Peas . . .	1,328	1,122	1,529	206	-201	18	-13
Total . . . .	32,903	23,549	24,966	9,354	7,937	49	32
(In Thousands of Tons.)							
Potatoes.	4,209	2,505	2,643	1,704	1,566	68	59

The present writer can testify, however, that the machine was kept going only by constantly reminding the rural community of the men in the trenches, and had it not been for the poignant sorrow and bitter tragedy of the war no power on earth would have kept the farmers to the programme. It is not that they are less patriotic than others, quite the contrary. But the system is not suited to the conditions of the countryside and so it lacks permanency. Post-war agriculture is adjusting itself to post-war economic conditions.

The volume is full of interest and will certainly appeal to a large body of readers.

(2) Teachers of agriculture generally will welcome the appearance of a little book on the history of the subject which they can place in the hands of their students, in the first instance to stimulate their interest, and afterwards as an introduction to larger works.

\* Mixed corn is shown separately in 1918. In previous years it is shown under wheat, barley, or oats.



Mr. Orr's book can confidently be recommended for this purpose.

The book is simply written and can be read without any extensive knowledge of English history: it is unbiassed and, for its size, it gives as good an account as we have yet seen of the course of events in British farming from the earliest times to the present day. The illustrations are excellent and well chosen from a wide range of sources: they show, side by side, the older and the newer types of implements or of animals, and afford admirable demonstrations of the great changes that have taken place since agriculture began to develop.

In discussing the post-war period Mr. Orr ends on a note of subdued optimism which we hope and believe is justified: "The market for farm produce is weak. Agriculture must share the bad fortune as well as the good fortune of the country and even of the world. In view of the magnitude of the war its evil effects will probably be very great and very prolonged. But however difficult times may be, there is promise for the future in the better feeling that exists between landlords and tenants, employers and employed, as compared with that which prevailed a century ago. There has been no poor-law payment of wages, and the difference between the treatment of the labourer then and now is an indication of the progress that has been made."

E. J. RUSSELL.

### Ore Deposits.

*Abriß der Lehre von den Erzlagerstätten: In Anlehnung an die dritte Auflage des Lehrbuches und unter Benützung hinterlassener Aufzeichnungen.* Von Prof. Richard Beck. Bearbeitet durch Georg Berg. Pp. xi + 408. (Berlin: Gebrüder Borntraeger, 1922.) 16s. 8d.

AS is stated by Dr. Berg in his introduction, this work, an abstract of the study of ore deposits, is an abbreviation of the large work in two volumes by Richard Beck. The original work was well known, and three editions have been published since it was originally issued in 1900. The general principle of classification remains nearly the same as that in the original work, and it must be admitted that, generally speaking, the changes that have been made have not made for a clearer understanding of this exceedingly complex subject.

As in the original, a clear cut is made between epigenetic and syngenetic deposits; the author defines these phrases as follows: in the former he includes deposits into which ore has been introduced only after the formation of the immediately adjoining country rock, while the latter term is restricted to magmatic

segregation in which the ore is formed simultaneously with the country rock. These basal definitions, however, are by no means satisfactory. The author's definition excludes from the syngenetic group sedimentary deposits, such as beds of ironstone deposited originally as bog ironstone, etc., and in fact Dr. Berg has treated such deposits quite separately from his syngenetic deposits and has placed them in his classification after the epigenetic deposits. Dr. Beck, on the other hand, looked upon such ores as syngenetic, and there is no doubt that his view is the sounder and leads to a clearer understanding of the entire subject.

Again, Dr. Berg devotes a separate section to the Gozzans or alteration products of existing ore deposits, formed above permanent water level, which may include both secondary enrichment and impoverishment of the deposits in respect of their metallic contents. He classifies these deposits as epigenetic on the grounds that certain deposits are in themselves not worth working except in the zone of secondary enrichment; perhaps, strictly speaking, there is something to be said for this argument, but it certainly does not make for a clear understanding of the subject. If distinctions are to be drawn between the deposit itself and its more or less altered outcrop, confusion is bound to result. In fact, one of the great faults of the work lies in the author's failure to appreciate that in dealing with such phenomena as ore deposits, where a natural system of classification is practically impossible, broad lines must be followed; even so, there will be numerous border cases which every student of the subject will treat on somewhat different lines. One of the most striking points in the book, which well illustrates what has just been said, is the minute subdivision of mineral veins based upon differences, and sometimes small differences, in their mineral contents. In this Dr. Berg has followed Dr. Beck, the need for simplification apparently not having occurred to him. The whole of the treatment of mineral veins may be described as somewhat antiquated, seeing that over one-third of the work is devoted to fissure veins. This diffuse treatment is reminiscent of the days when the overwhelming proportion of all metallic minerals (with the exception of iron ores) was derived from fissure veins, as was the case a century ago. To-day, on the other hand, the output from veins is relatively unimportant, and the author does not seem to have realised how great the change has been in this respect.

The author divides his subject into the following main groups:

- I. Magmatic segregations.
- II. Contact deposits.
- III. Mineral veins.

## IV. Epigenetic ore bodies.

V. Sulphuretted ore deposits mainly of epigenetic origin.

## VI. Ores formed by sedimentation.

## VII. Gozzans.

## VIII. Secondary (clastic) deposits.

Many of these groups are by no means satisfactory, inasmuch as the deposits included in them do not properly correspond to the titles given. Thus the author quotes as examples of magmatic segregation the magnetites in gneiss of the Lofoten Islands and the Kiruna ore, although he admits that the latter ore deposit is definitely younger than the adjoining eruptive rocks and accordingly not syngenetic with these. Similarly he includes among contact deposits, by which he understands those formed under the influence of contact metamorphism at or near the boundaries of the eruptive and the stratified rock masses, a number of deposits as to which he is bound to admit that he cannot ascribe their origin to any particular eruptive rock. He describes those as krypto-contact deposits, but obviously such a description is far from satisfactory. Among his epigenetic ore bodies he includes such deposits as those of Bingham and Bisbee, where the protore is undoubtedly syngenetic, gash veins and similar deposits in pre-existing cavities, true metasomatic deposits like the red hæmatites of Cumberland, and certain residual deposits, while his group of sulphuretted ore bodies is admittedly not a natural entity and contains examples of syngenetic, epigenetic, and indeterminate modes of origin. This method of dealing with the subject creates confusion rather than clearness; it is conglomeration, not classification.

There are various mistakes in geography, which should have been avoided; for example, the Sierra de Ronda is said to be on the Portuguese coast, and Leadville in England! Moreover, the work aims at describing every deposit of importance, but there are several notable omissions.

No doubt there is room for a good, small text-book on mineral deposits, but it will have to be on different lines from those of the present one; more care will have to be devoted to classification and to the discussion of the modes of formation of the deposits, and fewer examples, and those only typical ones, must be quoted, references to descriptions of others being generally sufficient. It is probably only in this way that the student can get a clear view of this complex subject. The work at present before us does not fulfil these conditions; it may be of use for reference to the experienced mining geologist who is not likely to be led astray by it, but it is scarcely a safe book to place in the hands of a beginner.

H. LOUIS.

## The Living Soil.

*Das Edaphon. Untersuchungen zur Ökologie der bodenbewohnenden Mikroorganismen.* Von R. H. Francé. Zweite Auflage. Pp. 99. (Stuttgart: Franckh'sche Verlagsbuchhandlung, 1921.)

"EDAPHON" is the name which, from their analogy to the plankton, Dr. Francé has coined to cover all the forms of life occurring in the soil. In spite of the very considerable amount of work that has been done in recent years on these organisms, very little of it is at present available to the general biological reader. There are text-books of agricultural bacteriology and a considerable number of scattered papers dealing with single organisms or groups of organisms from the soil, but most of these reach only the specialist. Dr. Francé has therefore performed a real service in writing a brief general account of the soil fauna and flora, its conditions of life, and the influences of the different groups of organisms on one another and on the soil.

As a general handbook to the subject, however, it suffers from one considerable defect, for during the past few years great advances have been made both in this country and in America, of which apparently Dr. Francé has as yet heard nothing, since he gives no references to any non-German work of a later date than 1912. Even a casual glance through recent numbers of the English and American journals would not only have given him many useful facts, but would also have suggested methods of technique which would have made his own investigations much more fruitful. His accounts in particular of the insects and flagellates give very little idea of the number and variety of these creatures occurring in the soil.

The observations on the ecology of the organisms would also have been more satisfactory if a little more statistical information had been given. It is not very useful to be told that in May a cubic millimetre of soil contained 15 organisms (omitting bacteria), whereas in August the number had fallen to 3, unless we are also told how much variation there is between duplicate samples taken at the same time or at brief intervals. Since Dr. Francé frequently reminds us of the close analogy between the edaphon and the plankton, one naturally recalls the wide divergences found in duplicate catches of the latter. Probably he is right in believing that the figures given are significant, but the reader who wishes to understand what are the effects of temperature, moisture, season, and the physical and chemical properties of the soil on the organisms living in it, is at a great disadvantage if he is not told just what is the degree of significance.

In spite of these defects, however, the present

volume contains a great many useful observations and a very lucid and stimulating review of the subject. One may question whether the biological influences have quite the dominating importance in the soil that is here claimed for them, and in particular whether the organisms found in it can as yet be satisfactorily used as a criterion of the agricultural properties of a soil; but the subject is still young and its possibilities are undoubtedly great.

### The Presentation of Thermodynamics.

*Vorlesungen über Thermodynamik.* Von Prof. Dr. Max Planck. Sechste Auflage. Pp. x + 292. (Berlin: W. De Gruyter and Co., 1921.)

ONE of the most universal generalisations that can be made about the study of mathematical physics is that everybody finds thermodynamics a very difficult subject. In consequence of this there have arisen several different ways of presenting it, which vary far more from one another than do the presentations in such subjects as dynamics or electricity. There is first the thermodynamics of the engineer, in which entropy is something steam has, which can be found from tables. Then there is the thermodynamics of the chemist, whose laboratory is stocked with semi-permeable membranes. He is a great designer of engines, but all his enjoyment of his wonderful instruments is spoiled by his perpetual suspicion that Nature is trying to score off him. Next, there is the thermodynamics of the mathematician; this scraps the chemist's machinery and does the whole business by means of Pfaffian forms, a peculiar branch of mathematics, and almost the only one in which it looks as if more comes out at the end than is put in at the beginning. Lastly, there is the super-man, who can see and count the atoms, who regards all the others as gamblers, though he is bound to admit that they know how to lay the odds. He occupies a position rather apart, being, so to speak, engaged in a study of the jurisprudence of thermodynamics.

Now (excepting the last), all these presentations claim to derive their results from the two laws of thermodynamics, but there is no agreed statement of those two laws. In most books the chapter on the Second Law is not opened by a formal statement of that law—as Newton's laws of motion would head the corresponding chapter in a book on dynamics—but it is necessary to have several pages of tendentious discussion first, to create the atmosphere in which the law shall be acceptable. This can only mean that the law as stated contains a good many implied assumptions. Some years ago Carathéodory, the pure mathematician, formulated the principles in a really

logical manner, and it is to be hoped—if we can believe that the human mind is by taste rational—that this formulation will be more successful in making the subject easy than has the exceptional variety in presentation which has hitherto prevailed. Carathéodory's work was transcribed a year or two ago in the *Physikalische Zeitschrift* by Born. He insists that there is no way of shirking the Pfaffian problem in some form or other, but gives a simple geometrical description of it; in the consequent deduction of absolute temperature and entropy there is some rather heavy work which could probably be simplified. But the most important modification is the new place taken by temperature in the presentation. In the ordinary way it occurs muddled up with the Second Law, but here it is taken out and introduced as the primitive idea—of course, measured on an arbitrary scale. The consequence is that the First Law no longer deals with quantities which are undefined, and the Second Law becomes a clear-cut statement instead of a jumble of two statements.

The new presentation is too recent to have been adopted in text-books, and it will be most interesting to see whether it is destined to drive out the older types. The book under review is of a class about midway between those of the chemist and those of the mathematician. That it has gone through six editions shows that it is a first-rate introduction to the subject; but it certainly can be criticised from the logical point of view, for it brings in absolute temperature by means of the perfect gas, and only later justifies it in the general case. It is a philosophical question whether it is legitimate to introduce ideas connected with reality by means of a hypothetical substance—perhaps it may be defended, like the introduction of rigid bodies in dynamics. But the point really is that this method is apt to leave the student with the idea that absolute temperature is in some way connected with perfect gases, an idea rather encouraged by many of the examples that are usually cited. It is surely a pity to start by dealing with a special case, when the whole argument is that Carnot's cycle works exactly as well whatever the substance in the cylinder. Apart from this criticism, however, the whole work is an admirably detailed development of the theory, with numerous illustrative examples from physical chemistry. The chief changes in the new edition are in connexion with the theory of solutions; in particular, an account is given of the theory of J. C. Ghosh of Calcutta, of the freezing-points of strong solutions, which would seem to have attracted more attention in Germany than in this country. There is also more said about the equation of state of solids and their expansion coefficients.

We have dwelt perhaps with undue weight on the question of fundamentals, because this seems to us a matter which should be put right. But the present work, supplemented by a proper treatment of those fundamentals, certainly constitutes an excellent course in the general theory of thermodynamics.

### Dialectic.

*Studies in the Hegelian Dialectic.* By Dr. John McT. E. McTaggart. Second edition. Pp., xvi + 255. (Cambridge: At the University Press, 1922.) 15s. net.

IT is curious that a book which professed only to be a study of Hegel, and deals with criticisms of the Hegelian method and principle current more than thirty years ago, should be reprinted to-day and present the same freshness and vigour to the reader now as it did then. This is the feeling with which one who read Dr. McTaggart's book on its first appearance now lays it down, having read it again from beginning to end. It contains the best exposition of the dialectic, and the best defence of the dialectic, and the best criticism of it by any living writer. The conclusion Dr. McTaggart reaches would be accepted probably even by the most convinced Hegelians, namely, the conclusion that the logic is of permanent value and the dialectic sound, but that the metaphysic is unsatisfactory and cannot be final. His own view would seem to be that the ultimate reality is a unity of personalities, but that this unity is not itself a personality. Most of this book was originally presented in papers read and discussed at the Aristotelian Society in the early 'nineties and published in *Mind*, for at that time the Society did not publish Proceedings. It is a living work to-day because, more than at any previous time, the problem of the methodology of science is in the forefront. Mathematical discoveries, which have caused a revolution in our mode of conceiving the physical universe, and the discoveries of the new psychology, which have profoundly changed our mode of conceiving the mind, have necessitated a reconsideration of what is implied in the experimental method. We have found a need for dialectic, for the logic of philosophy. The stone which was set at naught by the scientific builders of the nineteenth century is become the head of the corner.

In the thirty years which have elapsed since Dr. McTaggart's book was written there have been some notable attempts in philosophy to reform and advance the Hegelian dialectic. It would be interesting to know Dr. McTaggart's attitude towards them. In section 120 he seems almost to anticipate Croce's criticism of Hegel as failing to differentiate between "opposites" and "distincts." Also one would like

to know how far he considers that Gentile, in the theory he has worked out of the identity of philosophy with its history, has met his objection to the place assigned by Hegel to philosophy in the supreme triad of absolute mind. Dr. McTaggart's own recent work, "The Nature of Existence," gives the impression that he has himself moved away from the position of these early studies and has fallen under the spell of the opposite method to that of the dialectic, the method which is known as logistic and has its home in his college. It may be, however, that he is illustrating in his own mental development the dialectical advance through negation. In any case we can say that this republication of his early work is of the greatest value to those who are endeavouring to follow the constructive work in which he is now engaged.

H. WILDON CARR.

### The Methods of Ecological Investigation.

*Geobotanische Untersuchungsmethoden.* Von Prof. Dr. Eduard Rübel. Pp. xii + 290. (Berlin: Gebrüder Borntraeger, 1922.) 16s. 8d.

IT is now seventeen years since the first appearance of Prof. Clement's work on "Research Methods in Ecology," written at a time when this branch of knowledge was still in its infancy and its methods for the most part yet to be devised. Since 1905, however, considerable advances have been made, particularly in the two directions of intensive study of the habitat factors and the extensive study of the plant community.

The growth of the subject is indicated by the establishment, both in this country and in America, of specialised journals devoted to this field alone, and this growth has naturally been accompanied by the development of a definite technique for the study of plant societies. We therefore welcome the work before us, in which Prof. Rübel has aimed at giving us a survey of the present position of ecological methodology on the botanical side.

Broadly the subject matter falls into two sections corresponding to the two main lines of progress already mentioned. Of these the consideration of the factors of the habitat, climatic, edaphic, biotic and orographic, with the methods of their measurement, occupies nearly half the text.

The climatic section contains a useful account of several American types of atmometer, methods of measuring light intensity under water, etc. The section treating of edaphic factors is regrettably short, especially having regard to the extensive development in this direction. For example, details might usefully have been furnished of the freezing-point depression methods of estimating the concentration of soil solutions

and the more fundamental methods of chemical analysis. No description is given of a modern type of calcimeter such as that of Collin's, but only of the two Passon's calcimeters in which the sources of error still remain. Again, ecologists might reasonably hope to find in these pages an account of either the electrical or colorimetric methods for determining the hydrogen-ion concentration of soil solutions, or of the colorimetric determination of nitrates.

It is particularly in respect to physical and chemical methods, of which the details are often widely scattered in non-botanical literature, that the biological investigator needs most guidance. The elucidation of ecological problems is becoming every day more a question of the investigation of the chemical and physical properties of the environment as they affect the different species directly, and their relationships to one another.

The second part of the volume is devoted to a consideration of the plant community, and is a helpful summary of the recent work on the extensive side of the subject. Here are dealt with such aspects as frequency and the methods of its determination, the occurrence of "constants" and characteristic species, the life forms of plants as classified by Raunkaier, the chief plant formations and the important subject of cartography.

Prof. Rübél's considerable experience in the Swiss Survey lends especial value to his pertinent discussions of the various statistical methods. The results so obtained are often by no means free from the personal equation, and hence often have a spurious appearance of accuracy to which attention is rightly drawn. The classification of plant formations is, in essentials, that put forward by Brockman and Rübél in 1912, based largely on the physiognomy of the dominant species. The chief change is the creation of a new class termed *Saxideserta* for stony deserts in which cryptogamic vegetation predominates.

Ecology, from the very complexity of the problems with which it deals, must cull its methods from all branches of science, and if we have criticised omissions it is not without a due appreciation of the magnitude of the author's task and of the encyclopaedic knowledge requisite to its ideal performance.

E. J. SALISBURY.

### Avian Minstrelsy.

*Songs of the Birds.* By Prof. Walter Garstang. Pp. 101. (London: John Lane, The Bodley Head, Ltd., 1922). 6s. net.

IN his "Songs of the Birds" Prof. Garstang has given us an unusual but agreeable mixture of science and verse. His introductory essay on avian

song is a contribution to the science of the subject which deserves serious consideration. His attempts to set down on paper representations of the songs of different species are also interesting, although opinions will probably differ as to whether he has greatly succeeded where others have failed. Finally, there are the author's own verses about the songsters, often incorporating his representations of their own music; but these, together with the little sketches from Mr. J. A. Shepherd's humorous pencil, scarcely fall within the scope of a notice in these pages.

Prof. Garstang starts from the assumption that "birds are not automatic musical boxes, but sound-lovers, who cultivate the pursuit of sound combinations as an art, as truly as we have cultivated our arts of a similarly aesthetic character. This art becomes to many of them a real object of life, no less real than the pursuit of food or the maintenance of a family." He also, following Warde Fowler, places bird song on the æsthetic level of the rude music of primitive man. The songs of birds, he tells us, "are in each generation an expression of the whole joy of life at its climax of achievement and well being," and he holds that it is wrong to regard them as essentially love lyrics. These views are a welcome reaction from the too mechanical conceptions that are common, but there is at the same time some danger of their leading towards too anthropomorphic ways of thinking.

Much ingenuity has been expended at various times, and with indifferent success, on the attempt to translate birds' songs into human speech or musical notation. Prof. Garstang obviously approaches this vexed question with a knowledge of music and a sense of poetry, and his endeavours to place the matter on a firmer footing are, at the least, interesting and instructive. As "the bird is a minstrel, not a musician," and as "timbre and resonance, rather than musical pitch, constitute the dominating features of a bird's sounds," the author has adopted a syllabic notation. His view is that "the secret of representation lies not in punctilious imitation of every sound (which is unattainable), but in accuracy of phrasing combined with a fair approximation to the succession of dominant vowels and consonants." As we have said, however, opinions are likely to differ as to whether the question is really solved, for the personal factor enters so largely into both the hearing of the songs themselves and the reading of the written symbols. The reader who has an ear may thus best judge for himself whether a useful advance in the means of studying and describing bird music has been achieved by such examples as the following representation of the song of the willow-warbler:

*Sip, sip, sip, see! Tee, tew, wee, tew!*  
*Witty, witty, wee-wee, weewee!*

### Our Bookshelf.

*Columns: A Treatise on the Strength and Design of Compression Members.* By Dr. E. H. Salmon. (Oxford Technical Publications.) Pp. xvi + 279. (London: Henry Frowde and Hodder and Stoughton, 1921.) 31s. 6d. net.

THE question of the strength of columns is one of considerable difficulty, on both the theoretical and the experimental side, and the author is to be congratulated on the value of his contribution to this subject.

Dr. Salmon's book consists of three parts: Part 1 is a bibliography arranged chronologically and gives the author's name and the title of the work. Part 2 is an analytical discussion covering various methods of fixing the ends; in each case ideal conditions are first assumed, and then departures from these conditions are considered until the ordinary column is reached. Part 3, synthetical, contains accounts of various formulae used in practice and the experimental evidence on which they are based. The last two parts are taken substantially from a thesis submitted for the D.Sc. (Engineering) degree of the University of London. Part 1 in the thesis was historical, consisting of short summaries of each important memoir, including experimental work; it is unfortunate that, owing to the present impossibility of publishing the complete work, this section has been compressed into a bibliography of sixteen pages. The treatment in Part 2 is mathematical without unnecessary refinements.

Apart from the advantage of the presentation in one volume of much valuable work, hitherto scattered in many books and journals, the author's systematic treatment has led him to elucidate various new points, and will undoubtedly stimulate the reader in the same direction. For the same reason the suggestions given for future research must carry weight. Dr. Salmon considers that the most pressing point for future research on columns is the question of the degree of imperfection common in practical direction-fixed ends. This matter is of great importance in other structural members as well as in columns, e.g. arch ribs and encasté beams. We can thoroughly recommend the volume to all who are interested in the subject of the strength of materials.

*A Text-Book of Mineralogy: With an extended Treatise on Crystallography and Physical Mineralogy.* By Prof. Edward S. Dana. Third edition, revised and enlarged by Prof. William E. Ford. Pp. ix + 720. (New York: J. Wiley and Sons, Inc.; London: Chapman and Hall, Ltd., 1922.) 25s. net.

THIS well-known book was first published in the year 1877, and a second edition appeared in 1898. The present third edition leaves the form essentially unchanged, the close relation between the author's "System of Mineralogy" and this book having rendered it inadvisable to revise the chemical classification of the minerals until a new edition of that larger work can be undertaken. The distinguished author is now professor emeritus at Yale; he still retains the post of curator of Mineralogy, however, but being well advanced in years the revision of the book has been undertaken by Prof. Ford.

The principal changes appear to be the introduction of a section on stereographic and gnomonic projections, and improvements in the description and explanation of the optical properties of crystals. The reference to the very important recent work on the elucidation of crystal structure by means of X-rays, however, occupies only slightly more than one page, without a single illustration. On the other hand, however, there is a much longer and really valuable section on the determination of the refractive indices of microscopic crystals by the more recent improved microscopic methods of F. Becke and F. E. Wright.

We are glad to see that the references to classes of lower than full systematic symmetry as "hemihedral" and "tetartohedral" (possessing a half or a quarter of the full number of faces) is now only a passing one, as to an antiquated, misconceived, more or less discarded and inadequate method of description. The crystal classes are now referred to as possessing each their own definite elements of symmetry, the only truly scientific method of distinguishing them.

A. E. H. T.

*General Economic Geology: A Text-book.* By Prof. W. Harvey Emmons. Pp. xiii + 516. (New York and London: McGraw-Hill Book Co., Inc., 1922.) 20s.

STUDENTS and others interested in economic geology will appreciate Prof. Emmons's volume. The scope of the work is extremely wide and all of the following are dealt with: coal, petroleum, natural gas, metalliferous and non-metalliferous minerals of economic importance, and building stones.

The text as a whole shows a great resemblance to that of two of the author's previous works, e.g. "Geology of Petroleum" and "Principles of Economic Geology," but the section on coal is entirely new. The chapter on oil appears to be a précis from the former of the two books mentioned, and some parts dealing with mineral deposits have largely the same text and diagrams of the corresponding earlier work. The chapters on the non-metallic minerals, however, have been greatly enlarged, and contain much additional information.

It is evident that the author has written his "General Economic Geology" primarily for an American public, since all his examples, where possible, are from American localities, with little or no mention of occurrences of equal or greater importance in other parts of the world. An outstanding example of this is the 70 pages which he devotes to the coalfields of North America to the exclusion of fields elsewhere.

The value of the book is greatly enhanced by the addition of an excellent bibliography, which will allow of a more specialised study of particular areas when required. Moreover, the text throughout is plentifully supplemented with maps, diagrams, and half-tone blocks.

*Imperial Institute Handbooks. The Agricultural and Forest Products of British West Africa.* By Gerald C. Dudgeon. Second edition. Pp. xii + 176 + plates. (London: J. Murray, 1922.) 7s. 6d. net.

SINCE the first edition of this handbook appeared in 1911 many changes have taken place. The development of British West Africa has experienced a serious

set-back through the occurrence of the war, but useful lessons have been learned and many subjects have come forward or called for increased attention. The cultivation of cotton has been shown to be successful and profitable in Nigeria, in the northern provinces great progress has been made in perfecting a cotton originally grown from "American Upland" seed, while the southern provinces have produced increasing quantities of an improved native cotton of the type of "Middling American." The products of the oil palm and especially the kernel of the nut have been in increased demand for edible purposes, but improved methods of extraction are still awaited, and the successful cultivation of the oil palm in the Dutch East Indies and British Malaya threatens to rival the industry in West Africa. Successful plantations of Para rubber have been established in Nigeria and in the Gold Coast, and the latter has become the chief cocoa producer of the world. The extension and improvement of the Agricultural Departments will be a factor in developing the possibilities of the various territories in West Africa for which Great Britain is now responsible. The handbook will serve as a guide to all who seek information on the agricultural and forest products of British West Africa.

*Memoirs of the Geological Survey. Special Reports on the Mineral Resources of Great Britain.* Vol. 2: Barytes and Witherite. By G. V. Wilson, T. Eastwood, R. W. Pocock, D. A. Wray, and T. Robertson. With contributions by H. G. Dines. Third edition. Pp. iv + 119 + 6 plates. (Southampton: Ordnance Survey Office; London: E. Stanford, Ltd., 1922.) 3s. net.

THE issue of a third edition of this memoir shows public appreciation of the economic work of the Geological Survey; the revision has involved further visits to all the principal mines, and the records of output include those of very recent years. A brief sketch of the characters of the two minerals concerned and of their uses precedes the detailed account of the mines. Photographs of crystals, and some account of the relation of barytes to metallic sulphides in the field, might have added interest to this section; but the cost of the memoir to the public has no doubt been carefully considered. The graphic tables showing the total output go back only to 1890. It would be of interest to trace the quick response of the Derbyshire miners to the demand that arose in 1856. The earliest date mentioned on p. 64 is 1892; but in 1857, two years after the industrial development of barytes lodes was started in the county of Cork, Derbyshire produced as much as 9000 tons. The thoroughness of the memoir as a record of present-day mining is shown by the descriptions of methods of treatment of the ore at various places, and of means of transport.

G. A. J. C.

*The Edge of the Jungle.* By William Beebe. Pp. 237. (London: H. F. and G. Witherby, 1922.) 12s. 6d. net.

MR. BEEBE has a graphic pen. His account of the life of bird, beast, and insect as seen from a small clearing on the edge of the British Guiana forest gives a vivid and kaleidoscopic impression of teeming life. His capacity for close and careful observation and his

artistic power of selecting just the right details, combine to convey to the reader a feast of tropical colour, sound, and scent. It is impossible not to follow his account of, say, the happenings in the "army ants' home town" with an interest as tense as though he described the fortunes of human individuals. The transformation of "Guinevere" from a tadpole into a tree-frog holds the reader entranced. Mr. Beebe does not confine his attention entirely to his clearing; while on a visit to the gardens at Georgetown he was fortunate enough to see a group of manatees of which he records his impressions for the benefit of his readers. Incidentally he raises an interesting question as to the origin of flower growing for non-utilitarian purposes, which may suggest to the anthropologist a new field in which to view the influence of magic.

*Land Drainage.* By W. L. Powers and T. A. H. Teeter. Pp. ix + 290. (New York: J. Wiley and Sons, Inc.; London: Chapman and Hall, Ltd., 1922.) 13s. 6d. net.

LAND drainage occupies a large and important place in American agriculture, and the volume under notice is evidence of its prominence. It deals mainly with conditions in the Corn Belt and Western States, and is intended as a practical handbook from which may be obtained the most important details of procedure in the construction of drainage works. As these operations vary according to the nature of the land—reclaiming a marsh presents different problems from the draining of irrigated land which has begun to show signs of alkali—the authors have supplemented their general discussion by detailed descriptions of actual installations. These accounts include the balance-sheets of the operation, which show that in most of the schemes the increased crops have paid for the outlay in a short time. Particular interest attaches to the section dealing with drainage laws, and the manner in which the cost and the benefits of a proposed scheme for a district are divided among the farmers. The concluding chapter is devoted to the care and use of surveying implements, and a useful appendix of laboratory exercises is provided, in which the main principles of drainage are illustrated. B. A. K.

*Homework and Hobby Horses.* Edited by H. Caldwell Cook. (Perse Playbooks, No. VI.) Pp. xii + 58. (London: B. T. Batsford, Ltd., n.d.) 3s. 6d. net.

THE Perse Playbooks are by now sufficiently well known to educationists. This little volume—the sixth of the series—embodies a selection of poems, ballads, and carols which have been produced, with one exception, by boys of the Perse School as a part of the system of the play-method of teaching English composition. The authors are all under fourteen, and the facility of the verse and, generally, its smoothness suggest that the statement that English verse composition has no terrors for, at any rate, some of the boys, is well founded. Some of the compositions are avowedly parodies, others are obviously derivative, but many show a poetic feeling which is surprising, as well as a considerable command of an appropriate vocabulary. The incongruous, the mark of the unpractised versifier, is commendably absent. It is interesting to note that of the various classes of poems, the carols are by far the most successful.

### Letters to the Editor.

[The Editor does not hold himself responsible for opinions expressed by his correspondents. Neither can he undertake to return, or to correspond with the writers of, rejected manuscripts intended for this or any other part of NATURE. No notice is taken of anonymous communications.]

#### The Cause of Rickets.

THE scientific interest of the work that has been done and is reviewed in the leading article in NATURE of July 29, p. 137, is that it shows that ultra-violet light, acting on the skin, produces by a photo-chemical reaction a definite substance which circulates in the blood. This substance is able to replace vitamin-A in the food; whether wholly or only partially is not yet certain, although it should not be difficult to decide the question. If the former, it appears that light actually causes the formation of the vitamin, as suggested by Prof. Harden, or at all events some compound closely similar to it. Dr. Rollier finds in his sunlight treatment of tuberculosis that cod-liver oil is quite unnecessary; but, of course, his patients get vitamin-A in butter and so on. In rickets, vitamin-A can apparently be reduced to a very small amount if there is plenty of sunlight, but it is uncertain whether the vitamin can completely replace sunlight.

Looking at the evidence as a whole, it seems to me that the six or seven causes enumerated in Dr. Findlay's article may really be reduced to two and perhaps ultimately to one. These two are deficiency of sunlight and of vitamin-A. Taking the remaining suggested causes in the order mentioned, it is obvious that bone cannot be made without its constituents calcium and phosphate, and, as the article points out, this is not a matter of great practical importance, especially if a proper quantity of milk is included in the diet. As to the avoiding of cereals in favour of meat, it seems that the question here is really one of the rate of growth. There is no doubt that the more rapid the growth, the more vitamin-A is needed, probably because it is stored to some extent in the new tissues, especially if these consist of much fat. Prof. Mellanby's experiments showed clearly that the addition of carbohydrate to the diet of his puppies necessitated more vitamin because the growth was so much more rapid than on meat diet alone. It is of interest that Dr. Rollier's experience with tuberculous cases is at variance with Dr. Findlay's with rickets. Rollier finds that much meat is injurious, and that oatmeal is one of the best foods. At the same time, he deprecates over-feeding.

The next cause, rapid growth, has been dealt with above.

I am inclined to think that the factors included in bodily confinement and lack of exercise actually mean lack of sunlight. I understand that at Johns Hopkins Hospital it was found that the two factors mentioned were immaterial if exposure to ultra-violet light was given. It is very doubtful whether massage and electrical treatment have much effect. It is remarkable that the effects ascribed to these are obtained by Rollier in cases which of necessity have to lie quiet, such as tuberculous vertebrae, by the action of sunlight alone. The firmness and "tone," even growth, of the muscles is very obvious.

I doubt whether much advance is likely to be made by obscure references to increase of general metabolism as an explanation of the action of ultra-violet light. The dogmatic statement that animal protein is of especial value rests on no good evidence. Apart from vitamin-A, diet does not seem of great import-

ance, and even this vitamin may be reduced to a very small quantity in presence of adequate sunlight.

Should not "vitamin-B" in the seventh line from the bottom of the first column on p. 138 read "vitamin-A"? And also in the sixth line from the top of the second column?

I would conclude that we can reduce the effective factors in the prevention of rickets to vitamin-A and sunlight. It may be found to sunlight alone.

W. M. BAYLISS.

University College, London.

I AM much obliged to Sir William Bayliss for pointing out my inexcusable mistake of writing "B" for "A" vitamin. One of the advantages of solving the rickets question may be that we shall be able to use a more definitive and memorable nomenclature. "Anti-rachitic" factor is at present plainly inadmissible; it would be pleasant to call it "Hopkins' stuff," were it not obvious that the identity of the substances which promote growth and have a preventive influence on rickets is still an open question.

On the general question it seems to me that Sir William Bayliss is too ready to accept as a demonstrated fact that ultra-violet light, acting on the skin, produces by a photo-chemical reaction a substance which is equivalent to or identical with the factor in cod-liver oil which influences growth and rickets. It is a very tempting hypothesis because it brings into line a number of apparently discrepant observations. But it neglects a great mass of clinical experience which relates the occurrence of obvious rickets to the total intake of food and to the influence of exercise and massage. This experience may not be capable of the precise formulation one would like, it may not be of any very high order of observational or experimental accuracy, but it has, I think, none the less to be taken into account. It is known too, though here again the data are not beyond criticism, that light increases the rate of general metabolism in experimental animals.

The alternative hypothesis suggested in the article seems to have the advantage of bringing all the more or less certain and uncertain data which are available into line. What is, of course, needed is a whole series of clinical experiments made with the control and precision of the observations carried out by Dr. Harriette Chick and her colleagues in Vienna. Experiments of this kind are laborious and difficult. Meanwhile the practical sanitarian can get to work with sunlight and cod-liver oil and abolish the disease before any one has found out what part of the spectrum is effective.

THE WRITER OF THE ARTICLE.

#### The Phenomena and Conditions of Sex-change in the Oyster (*O. edulis*) and *Crepidula*.

IN NATURE of December 15, 1921 (vol. 108, p. 500), I described an experiment from which a sexually mature male oyster was obtained of a maximum age of 23 weeks, from the River Blackwater. In this experiment a fair number of oysters born in 1921 were obtained on specially prepared shells kept isolated *in the sea* with the view of determining the conditions of sex at a known age at later intervals. With the aid of a Government grant from the Royal Society it has been possible to follow up the experiment this year with the following highly interesting results. The young oysters this year were found mostly to be sexually mature or had recently spawned. In one sample of 32 examined from shells on the south shore, River Blackwater, most of the individuals were males, but one large individual (28 × 31 mm.)



was found on July 3 to be carrying thousands of young oyster embryos. This same individual was taken to Plymouth and kept alive; on July 18 it was again examined and found to be practically ready to spawn as a male.

It is, therefore, clear that even in England, in such suitable circumstances as occurred in 1921, oysters may become mature as females in the first year of growth, and further that a one-year-old oyster which had spawned as a female in the summer following that in which it was born changed immediately after spawning into a male. An examination of about 300 young oysters from the oyster-beds, estimated as one-year-old oysters from comparison with the known one-year-olds, gave the same result as that obtained from the examination of the spat known definitely to have settled in 1921, namely, that all the smaller ones were males but that some of the larger ones were either females or had already spawned as females and were changing or had changed into males. From these results the conclusion is drawn that all oysters are born as males, but may or may not change into females at an age of one year. The proofs for this statement are not yet sufficient to establish it as a fact, and indeed actual proof could only be obtained in the most fortuitous circumstances. The kind of result required to amount to proof would be one which gave 1000 individuals all males out of 1000 individuals examined, but as oyster larvae settle at different intervals over a period of several months, a heterogeneous population with regard to age—apart from other causes—results unless very special precautions are taken. Since, however, sex-change may occur very rapidly, a difference in age of a few months in young oysters is sufficient to give time for sex-change in a collection of rapidly growing oysters whose greatest age is not more than one year, hence the difficulty. In spite of the difficulties, however, the knowledge of the conditions of sex-change mentioned above will help towards designing an experiment to lead to a definite result.

An extremely interesting result follows the observation that an oyster may function as a female at an age of one year, namely, that Gerbe's work in 1876 (*Revue et Magasin de Zoologie pur et applique*, 3 serie, iv.) can be regarded as confirmed. Gerbe examined 435 one-year-old oysters and found 35 with spawn in the gill, 127 with eggs in the gonad, 189 with sperm in the gonad, and presumably 84 with the gonad undifferentiated. An additional observation supporting these was also obtained from the Blackwater experiment mentioned above. A few Portuguese oysters (*O. angulata*) settled on the shells at the same time as the native oysters. By good fortune one ripe male and one ripe female were obtained. An artificial fertilisation made from these two individuals gave a very good proportion of swimming oyster larvae and quite as good as a control gave an adult Portuguese oysters.

Thus Gerbe's results—although nearly 50 years old—may be accepted and taken into account definitely in discussions on sex in the European oyster. There is nothing in his results at variance with the observations described above. The view one naturally took of Gerbe's results—prior to the writer's observations given above—was that European oysters at birth developed in approximately equal numbers into males and females, and in view of sex-change afterwards taking place from female<sup>1</sup> to male and almost certainly also from male to female, the sex-phenomena in this species appeared to be unique. The rapidity of sex-change in oysters must now,

<sup>1</sup> More than 100 cases of authenticated change from female to male have now been accumulated.

however, be taken into consideration, and the writer's view of the sex-changes in the young oyster found to be carrying embryos this year may be recapitulated. That oyster settled some time in 1921 after June 9, it is predicated that this oyster became sexually mature as a male and spawned as a male in the summer of 1921 (see NATURE, December 15, 1921). On July 3 this year this same individual had spawned as a female and was carrying thousands of young, and on July 18 this same individual was again sexually mature and practically ready to spawn as a male. Thus this oyster has already had two and probably three experiences of sex alternating from male (?) to female and from female back to male within about one year. It is hoped to follow further sex-changes in this particular oyster, which is still alive, for its last condition of sex, namely as a male, was determined by tapping the gonad through a boring in the shell. It has been found that if the boring and tapping operations be carefully performed an oyster can easily and quickly recover and cement over the boring on the internal face of the shell.

The definite information obtained from this one oyster is corroborated by sex-conditions in other young oysters taken from the grounds whose age could be determined as one-year-old oysters with practical but not with absolute certainty. As indicated above, however, the conditions in 1921, namely the unusually long warm summer, were highly abnormal, and it is not to be expected that one-year-old female oysters will often occur in British waters.

The rapidity of the sex-change in oysters is paralleled by a similar observation on sex-change in the American slipper-limpet (*Crepidula fornicata*) in the same series of experiments in 1921-22. *Crepidula*, moreover, has undoubtedly a similar span of life to that of the European oyster. Sex-change from male to female occurred in *isolated* slipper-limpets (up to 26.5 mm. long) in the same period as that observed in the oyster, but unfortunately none of the sex-changed limpets were actually in spawn at the time of examination although the gonad in several cases was full of either ripe or fairly large ova, and the penis had been reduced to a mere discoloured trace. Individuals of a similar age settled on other slipper-limpets had the normal beautifully-shaped and well-developed healthy black penis of the young male. (See Orton, Proc. Roy. Soc., vol. 81, B, 1909, p. 469.)

The conditions under which sex-change occurs in the oyster and the slipper-limpet are of much general interest. In the oyster development of both the male and female sex-elements can occur in the winter and spring period. We also know that male-elements can begin and attain full development in the summer and autumn, but as yet we have no definite information about the development of the female sex-elements in the summer and autumn. Experiments have been started to obtain information on the latter problem, but until that information is obtained one is not in a position to discuss the possible causes of sex-change in the oyster. It would appear, however, that the factor for sex-causation is within the control of the organism and not in external conditions, but it will be more profitable to await further information on sex-phenomena before discussing the question fully. In *Crepidula* there is no doubt that sex-change occurs in young forms when the young males cannot function as males; on the other hand, if young males settle down on females, they undoubtedly remain males and function as such for a variable time, which may be as long as five or six years or as short as one year, but again the underlying factor appears to be that of opportunity to function as a male. The

development of the male sexual elements in *Crepidula* is certainly independent of season, and so also apparently is that of the female sexual elements, since *Crepidula* breeds almost continuously from about March to December.

The males of *Crepidula* can certainly recognise females by some particular sense as yet unknown, as will be seen from the following facts. In examining a large number of chains of *Crepidula* (see Orton, 1909, *loc. cit.*), small to medium *Crepidula* were often found isolated and settled on the left-hand side of the females. Now this is the wrong side to permit of copulation, but in spite of the fact that copulation could not be effected these individuals were found to have an unusually fat and extensible penis capable of stretching probably twice as far as usual. In the experimental observations described above it was found that isolated *Crepidula*—certainly not older than those settled in the wrong place—had their penis absorbed. The conclusion is obviously reached that the males on the females knew that the latter were there and tried their best to reach them, whilst the totally isolated ones have resigned themselves unreservedly to a complete sex-change. It is only since proof has been obtained of rapid sex-change following complete isolation that a satisfactory explanation could be given for the phenomena of the misplaced males, but the explanation given above has for a long time been suspected of being the correct one.

J. H. ORTON.

Marine Biological Laboratory, The Hoe,  
Plymouth, July 25.

#### Wegener's Displacement Theory.

I QUITE agree with Mr. Lake's remarks (July 15, p. 77) as to the unsuitability of the tracing-paper method of investigating the merits of Wegener's hypothesis. All who wish to pursue the subject will do well to adopt his suggestions as to the practical method.

For some time I have been engaged on the subject, and, though I must plead guilty to the use of the tracing-paper method in the first instance—and there is this to be said in its defence, that we are attacking the master with his own weapon—results certainly warrant Mr. Lake's mild censure that for the truth of Wegener's theory to be accepted we must also believe in a great degree of plasticity for the earth's crust.

If the American coast be superimposed on that of Africa, the parts that coincide (according to Wegener, with a divergence of never more than 100 kilometres) are confined to that represented on the African coast by the distance from Kamerun to a point slightly north of the mouth of the Orange River. There is a divergence along the coast of Cape Colony, and an angle of approximately  $15^\circ$  between the superimposed coast of South America (N.E. coast of Brazil, etc.) and the African coast along the Gold Coast, Ivory Coast, Liberia, etc. These divergences may be easily accounted for by comparatively recent denudation, or fracture.

Assuming the truth of fracture—after Wegener—along the line Kamerun to Orange River, the Zwarte Bergen of Cape Colony certainly do fall into place exactly with the Permian cordillera of the Pampas. But this added coincidence merely leads us into greater difficulty. For to make the superimposed American coast coincide with the African coast in this manner, we have to swing the American continent through an angle of  $45^\circ$  from its present position.

This leaves us with Newfoundland in the position approximately  $45^\circ$  W.,  $32^\circ$  N.—in the Atlantic Ocean.

The Hercynian Appalachians—another of Wegener's "test" ranges—appear in a position in the Atlantic north of Cayenne, stretching in a general N.N.E. direction (along the line  $52^\circ$  W.,  $8^\circ$  N.— $47^\circ$  W.,  $20^\circ$  N.). They are in the right direction for joining up with the British Hercynian range, but are separated therefrom by a distance of ocean above 2000 miles.

To lessen this distance, and bring it within a reasonable distance of the British Hercynian range for joining-up purposes, we cannot allow any bending of the American continent. Any alteration in the relative positions of North and South America throws the direction of the Appalachians out absolutely and entirely. The only way the joining-up can be done for both the Zwarte Bergen-Buenos Ayres range and the Hercynian range on both sides of the Atlantic is either (1) a great movement of the Eurasian continent south-west, or (2) a movement of the African continent south to a distance of about 500 miles from its present position, and at the same time a rotation about an axis somewhere in the neighbourhood of Suez (for example) of not less than  $50^\circ$ .

In other words, since the fracture, either the Eurasian continent has been rotated in a general S.E. direction (clockwise) or the African and Indian masses in a N.E. direction (counter-clockwise), or both these motions have taken place, from a centre somewhere in the Suez-Madeira Islands line.

Are the Himalayas, the Carpathians, the Alpine system, the Atlas Mountains, the result of the clashing together of the African-Indian, European-Asiatic continents by these movements? As Prof. Sollas has reminded me, the first word on Wegener's theory lies with the astronomers and physicists. To them I leave the task of finding a force which has acted in two parallel directions west on the North and South American continents, making their advance west without rotation relative to each other and overcoming the resistance at the expense of the Andes Cordillera and its continuation in North America, and has at the same time driven the Eurasian and Asiatic continents south-east and the African-Indian continent north-east (relative to the Americas) with such determination that the great folding of the Himalayas-Alps line resulted—and waited until Tertiary times to do most of it.

E. R. ROE-THOMPSON.

St. Edward's, Oxford.

#### The Elliptic Logarithmic Spiral.

I AM much obliged to Mr. Wright for his correction (*NATURE*, July 8, p. 40). I had made a search in English and Continental books on curves and concluded that this spiral had been overlooked as a curve. But it appears to have been recognised in connexion with the spherical pendulum. Prof. Lamb in his "Dynamics," p. 288, as I now find, refers to the curve as "a kind of elliptic spiral," and Dr. Besant describes it as "an ellipse gradually shrinking in size."

I take, however, a little uncton in having given the curve a name, especially as it seems to be of importance in damped elastic systems with one degree of freedom, and in fact it may be called a characteristic. Thus in the elastic system without friction, the force displacement diagram is a straight line; with fluid friction varying as the velocity, we have the elliptic logarithmic spiral; and with solid friction, a series of parallelograms. The dissipation per cycle, its rate during the cycle, as well as what may be termed the timbre of the motion, are in this view brought out very clearly.

H. S. ROWELL.

15 Bolton Road, W.4.

**Pairing and Parthenogenesis in Saw-flies.**

As the result of recent experimental studies in the biology of saw-flies of the family Tenthredinidae, with particular reference to their parthenogenesis, I have been struck by the dearth of information as to their mating habits. My observations have revealed a novel point which I wish to record; and, in order to discuss its significance, I present first a brief summary of certain points relative to saw-fly breeding.

1. Females of *Athalia lineolata* Lep., on collecting, were found to be greatly outnumbered by the males; they paired frequently and probably were polyandrous. (The writer has a paper on this in the press.)

2. In certain species, e.g. *Pristiphora pallipes* Lep., the male is excessively rare.

3. In certain species, e.g. *Allantus* (*Emphytus*) *pallipes* Spin., no male has been taken or bred.

4. Some 30 species produce males only by parthenogenesis; some 13, females only by parthenogenesis; about 6 produce both sexes similarly. (See lists of Cameron and Enslin.)

5. A large number of species other than the above are facultatively parthenogenetic, and future work will greatly extend the list. (See work of Miss Chawner and the writer.)

6. Certain species, in captivity at any rate, refuse to pair. (See work of Fletcher, Miss Chawner, and the writer.)

7. Females of *Platycampus luridiventris* Fall., after persistently ignoring the males, may lay eggs parthenogenetically while kept with their food plant under a glass vessel and in the presence of the males. (Writer's observation.)

8. Virgin females of *Phymatocera aterrima* Kl., after laying eggs (which gave healthy larvæ) paired with males presented to them. Unfortunately the females were about spent before pairing and did not lay again.

9. A virgin female of *Nematinius luteus* Panz., after laying eggs which gave healthy larvæ, paired with a male and then, subsequently, laid other eggs. Unfortunately, through the wilting of the alder twigs, which I was compelled to use instead of young trees, I have been unable to rear the presumably fertilised eggs which were laid after the asexual batch. I cannot state, therefore, whether this female's parthenogenetic offspring are different in regard to sex ratio or in germinal constitution from the offspring of the batch produced after fertilisation. This I am hoping to elucidate later in this season by the use of other species.

Points 1-4 are fairly well known, but Nos. 5 and 6 are probably known only to the few workers who have studied the group, while Nos. 7, 8, and 9 result from my studies, and being new, so far as I am aware, they form the *raison d'être* of this note.

These facts warrant the suggestion that in saw-flies the total sexual or partial sexual indifference of the sexes is a method for regulating (a) the numerical balance of the sexes and, *ipso facto*, (b) the amount of amphimixis necessary for the preservation of the species.

Again, the female saw-fly, by refusing or accepting fertilisation, or by first refusing the male, then laying asexually, next accepting fertilisation and, lastly, laying presumably fertilised eggs, achieves the same ends as the queen bee, which after fertilisation, produces females and workers from fertilised eggs, and males (drones) from unfertilised eggs. (This assumption, of course, rests upon the fact that the chromosomal complement of the females and workers is twice that of the drones.)

The survival value of the parthenogenetic production of females and of both sexes in certain

species is not difficult to apprehend, but the production of males only has presented a seemingly freakish and puzzling problem. The solution has been obscured by its being a laboratory observation, isolated, and uncorrelated with a knowledge of what occurs in nature or with such a fact as I have just presented. Doubtless males only may be produced in nature by certain females, but my observation suggests two further possibilities—that (1), in nature, certain females of a species may lay male-producing eggs and, subsequently, after fertilisation, eggs producing both sexes; (2) a certain number of females are set apart as virgins for producing males only, while others pair and produce both sexes. (There is too, of course, the remote possibility that fertilised eggs may yield only females sometimes.)

With such a range of possibilities for the production of the sexes the process of gametogenesis in saw-flies is likely to prove more complicated than has hitherto been supposed and may account for recent anomalous results.

Assistance in prosecuting the work has been rendered through a grant from the British Association.

A. D. PEACOCK.

Zoological Dept., Armstrong College  
(University of Durham), Newcastle-on-Tyne.

**Some Significant Relations in the Quantum Theory of Spectra.**

THE non-radiating orbits of Bohr's atom are given by the relation

$$a_n = \frac{\tau_n^2 h^2}{4\pi^2 m e^2 E} \dots \dots \dots (1)$$

The frequency of the wave emitted in jumping from one orbit to another is given by the energy relation

$$h\nu_{n+m \rightarrow n} = A_{n+m} - A_n \dots \dots \dots (2)$$

or

$$\nu_{n+m \rightarrow n} = \frac{2\pi^2 m e^2 E^2}{h^3} \left( \frac{1}{\tau_n^2} - \frac{1}{\tau_{n+m}^2} \right) \dots \dots \dots (3)$$

The convergence frequencies, given by the values of *m* equal to infinity in (3), are given by

$$\nu_n = \frac{2\pi^2 m e^2 E^2}{h^3 \tau_n^2} \dots \dots \dots (4)$$

and correspond to radiation emitted by an electron falling into the orbit *a<sub>n</sub>* from rest at infinite distance. The frequency *ν<sub>n</sub>* involves *τ<sub>n</sub>* for only one orbit, and may be regarded as associated with that orbit.

Between (1) and (4) we have immediately

$$a_n \nu_n = \frac{eE}{2h} = \text{constant} \dots \dots \dots (5)$$

Or, the frequency associated with an orbit is inversely proportional to the radius of the orbit for the same kind of atom.

The average kinetic energy of a particle describing a S.H.M. of amplitude *a<sub>n</sub>* and frequency *ν<sub>n</sub>* (instead of the orbital frequency  $\nu = \frac{4\pi^2 m e^2 E^2}{h^3 \tau_n^2}$ ) is

$$\frac{m\pi^2 a_n^2 \nu_n^2}{h^2} = \text{constant} \dots \dots \dots (6)$$

for the convergence frequencies of the same atom.

In his theory of chemical reaction and reactivity (Transactions of the Faraday Society, vol. xvii. Part 3, May 1922) Baly assumes (1) that an atom can gain or lose energy in terms of the elementary quantum of energy; (2) that the physical change, attending such gain or loss of energy, occupies a definite period of time which is the same for all atoms; (3) that the elementary quanta of all atoms are integral multiples of a fundamental unit which very probably is the elementary quantum of the hydrogen atom.

Equation (2) means physically that the energy difference  $h\nu$  is transferred from the atom to the ether, where it resides as the energy of vibration of a shell of ether, the radius of the shell expanding with the velocity of light. Baly's second assumption gives us the thickness of this shell. If the time occupied in releasing the energy  $h\nu = \Lambda_{n+1} - \Lambda_n$  be  $k$  seconds, the number of wave-lengths generated is  $h\nu$ . The thickness of the shell is therefore

$$h\nu\lambda = kc, \quad (7)$$

which is constant and independent of frequency.

Again, as the energy radiated is  $h\nu$ , and the number of pulses equal to  $h\nu$ , the energy radiated per period of vibration, or the energy in a shell of ether of the thickness of one wave-length, is equal to

$$\frac{h\nu}{k} = \frac{h}{k} = \text{constant} \quad (8)$$

It is interesting to note that Baly's third assumption, viz.

$$h \propto E, \quad (9)$$

makes the constants of equations (5) and (6) identical for all atoms. For similar identity of the constant of equation (8) it is necessary that, like  $h$ ,

$$k \propto E. \quad (10)$$

SATYENDRA RAY.

University College, London, W.C.1.

July 12.

#### Extraction of Radiolaria from Oozes.

I HAVE recently obtained some deep-sea radiolarian ooze from which I am endeavouring to extract the shells with as little damage to them as possible. I have tried the method advocated by Mr. Martin J. Cole, in which disintegration is brought about by prolonged boiling with a strong solution of sodium carbonate, and also another method in which the deposit is boiled with a saturated solution of sodium acetate, cooled till crystallisation has taken place, and then warmed till the mass has melted and boiled again, repeating this process several times. Although the smaller shells are successfully extracted by this means, I come across many large fragments of beautiful silicious formation, evidently the result of the breaking up of larger and more delicate ones.

I wonder if any readers of NATURE could tell me of a better method of extraction, whereby I may obtain these larger ones entire? If so, I shall be extremely grateful. Evidently the above methods of extraction are too drastic for these more delicate forms.

H. L. THOMAS.

Dyffryn Vicarage, Neath, S. Wales,  
July 10, 1922.

MR. THOMAS does not state whether his radiolarian oozes are recent or fossil. The two methods which he has employed are primarily intended for the disintegration of fossil earths such as the Barbados material, and as they depend for their efficiency on the disruptive action of crystallisation and the solvent action of alkalis on silica, they are necessarily more drastic in their action than is necessary for the cleaning of recent deposits.

Recent radiolarian deposits differ greatly in their nature, according to the rate of deposition and the depth. In some cases where the ooze has been rapidly formed it requires no further treatment than washing under a gentle stream of water on sieves of various grades. This method has the additional advantage of preserving the calcareous organisms, which are retained on the coarser sieves with the

larger Radiolaria. The smaller forms pass through all sieves with the diatoms, etc., and may be separated from the muddy water by elutriation and decanting. If it is not desired to retain the calcareous forms the material may be treated with nitric acid. The general treatment may be found in Cross and Cole's "Modern Microscopy," pp. 257-261 (Baillière, Tindall and Cox, 1922).

Some recent radiolarian oozes have come under my notice in which the rate of deposition has been so slow that the material is already in a subfossil condition, laminated in structure, and with the organisms more or less infiltrated with manganese. Such oozes are refractory; they contain scarcely any calcareous matter and so are resistant to acid treatment. They can be broken down only by repeated treatment with hot soda solution alternated with drying, and such methods are necessarily destructive to delicate organic structures like the larger forms of Radiolaria.

ARTHUR EARLAND.

#### An Attempt to Influence the Rate of Radioactive Disintegration by Use of Penetrating Radiation.

INVESTIGATIONS carried out by Ellis (Proc. Roy. Soc. 101, 1, 1922) at the Cavendish laboratory lead to the conclusion that quantum dynamics probably apply to the nucleus of the atom and lend support to the assumption that the emission of  $\gamma$ -rays from the nucleus precedes the disintegration process. This highly interesting hypothesis suggested an investigation whether the rate of radioactive disintegration can be influenced by exposing the substance to the action of penetrating radiation. Could the nucleus be induced to take up a  $\gamma$ -ray impulse supplied by an exterior source, it would mean a change in its stability and so most probably in the rate of its disintegration. As  $\gamma$ -ray source about 800 mg. radium element were used, and experiments carried out with uranium in radioactive equilibrium with UX, and with radium D in equilibrium with radium E.

(a) *Experiments with Uranium.*—The thin-walled glass tube containing the radium preparation was placed for six weeks on a 2 mm. thick layer of uranium oxide of 1 cm.<sup>2</sup> surface; by this arrangement practically all kinds of  $\gamma$ -rays emitted by the radium and all  $\beta$ -rays except the very soft ones reached the uranium preparation. By measuring the  $\beta$ -radiation of the uranium X in equilibrium with uranium before and after the experiment no change amounting to more than 0.1 per cent. in the activity could be detected.

Now, from the uranium quantity used, about 15,000 atoms break down in one second, so we can conclude from this negative result that the natural disintegration of our uranium preparation was certainly not followed by an artificial disintegration of more than 15 atoms per second. The radium preparation employed emits about  $10^{11}$   $\gamma$ -ray quanta in the time unit, about 0.1 of which was absorbed by the uranium atoms, so it follows that the absorption of  $15/10^{10}$  of the emitted  $\gamma$ -impulses by the nuclei of the uranium atoms would have already been sufficient to produce a detectable change in the rate of the disintegration of the uranium.

(b) *Experiments with Radium D.*—1.2 g. radiolac chloride from Joachimsthal of 1 cm.<sup>2</sup> surface was treated in the same way as the uranium oxide for 51 days. The  $\beta$ -activity due to RAE in equilibrium with RAd measured before and after the experiment showed no difference amounting to more than 0.2 per cent. Preliminary experiments with X-rays have similarly given a negative result.

G. HEVESY.

University, Copenhagen, July 11, 1922.

## Black Coral.

By Prof. SYDNEY J. HICKSON, F.R.S., The University, Manchester.

IN a short article by Prof. J. Stanley Gardiner published in NATURE of December 15, 1921 (vol. 108, p. 505), attention was directed to the use of black coral by the natives of Java for making bracelets which are believed to act as a cure for rheumatism and to the widespread belief, "from Suez to the most distant parts of the Pacific," in the efficacy of certain magical powers of this substance. The use of black coral for this purpose is not only very widespread at the present day but has been prevalent also among both barbaric and civilised races from time immemorial. The *ἀντιπαθές* of the ancient Greeks was in all probability a kind of black coral, and was used as an antidote to the stings of scorpions and for other medical and magical purposes. According to some of the older writers the herb given by Mercury to Ulysses as a charm to protect him from Circe was a piece of Antipathes. Rumphius quotes Salmasius as having written in his notes on Solinus that Antipathes was used as a protection against sorcery. Pliny refers to it in his alphabetical list of stones. He says, Book XXXVII., Chapter 54, "Antipathes is black and not transparent: the mode of testing for it is by boiling it in milk, to which, if genuine, it imparts an odour (?) like that of myrrh." Dioscorides regarded Antipathes as a kind of black coral which was possessed of certain medical properties.

These and other references to the substance by ancient Greek and Roman authors do not, it is true, give us any certain clue as to the identity of their Antipathes, and it is only by indirect circumstantial evidence that the conclusion is arrived at that it was the axis of one of two or three kinds of marine flexible coral.

The definition of the word "corallium" as used in the time of Pliny may be derived from the comment he makes upon Gorgonia. "Gorgonia nihil aliud est quam curallum: nominis causa, quod in duritiam lapidis mutatur emollitum in mari; hanc fascinationibus resistere adfirmant."

There is no truth in the belief that corals are soft in the sea and become hard when exposed to the air, and we cannot, in modern times, accept the statement that they have the power of resisting fascinations; but it is reasonable to interpret this definition by Pliny to mean that to the Romans of his time coral was a marine substance with a soft cortex when fresh and that it was commonly believed to possess certain magical properties.

Pliny's milk test for Antipathes is interesting but unfortunately very obscure. The phrase he uses is "experimentum eius, ut coquat in lacte: facit enim id murrae simile." But similar to myrrh in what respect? In odour, in colour, or in form? Solinus considers it to have been similar to myrrh in odour (Collect. v. 26), but other authors have interpreted Pliny to mean similar to myrrh in colour. I have recently applied this test to a piece of Antipathes in my possession and have found after prolonged boiling in milk there is a faint odour resembling that of heated

myrrh, but the colour of neither the milk nor the coral seems to be in any way affected. For this reason I am inclined to believe, until my experiments on this subject are extended, that Pliny meant to say "similar in odour to myrrh."

Let us turn now to another fragmentary indication of the ancient use of black coral. The word "coral" is to be found in two texts of the English version of the Bible (Job xxviii. 18 and Ezekiel xxvii. 16). Prof. Peake has kindly informed me that Gesenius and other commentators consider that the Hebrew word "Ramoth" which is translated "coral" in the E.V. means "black coral" and that the word "Peninim" which is translated "rubies" in the E.V. really means "red coral." Thus Job xxviii. verse 18 should read: "No mention should be made of black coral or of pearls: for the price of wisdom is above red coral." I am not competent to form any definite opinion on the views of these commentators; but if they are right and black coral was known to the ancient Jews there may also be some explanation of a remarkable passage in the writings of Josephus.

In his book on the Antiquities of the Jews (i. 3. 6) Josephus relates that according to Berosus, the Chaldean, there is still some part of Noah's Ark in Armenia, and the natives carry off pieces of the bitumen (pitch?) from it to make into amulets for averting mischief. We have in this passage reference to a substance like bitumen (*i.e.* black and flexible when heated) which was made into bracelets and believed to possess magical properties. Of course, it may not have been black coral at all, but if black coral accompanied by the beliefs in its efficacy against evils of many kinds was transported to distant parts of the world, as we know red coral was transported at that period, it would not be remarkable if it became associated with the Noah's Ark myth. It would be a matter of great interest if scholars learned in Jewish antiquities could throw some further light on the use of either black or red coral by the children of Israel in early times.

The making of amulets from the pitch of Noah's Ark, and their use for averting mischief, brings us back to the statement in the article in NATURE mentioned above that the natives of Java make bracelets of black coral for curing rheumatism. The most complete account of this superstition in the Malay Archipelago is to be found in Rumphius's "Amboinsch Kruidboek" (xii. p. 195), published in 1750, in the article on *Corallium nigrum* or *Accarbaar iiam*. Rumphius says that the natives make bracelets of it by soaking it in cocoa-nut oil and bending it into the form required over a slow fire while smearing it all the time with oil. It is then polished with a rough leaf. Sometimes it is inlaid with gold or silver ornaments. It is supposed to confer on the wearer all kinds of blessings (*segeningen*) and to protect him from sorcery. It is sometimes made into sceptres for the chiefs and is also made into a powder by grinding with a stone, mixed with water and drunk as a medicine.

It would take too much space to give in detail the various diseases for which black coral was used as a remedy; but there is one point of difference between the account given by Rumphius of the use of the bracelets in his time and the account given by Mr. Pownall in his letter quoted in NATURE. Mr. Pownall says "the natives maintain that it must be used quite plain; and ornamentation of gold or silver renders them quite useless." Rumphius says that they ornament the inside of the bracelets with gold figures because they say, and "not without reason," that the coral must scratch the skin if it is to do any good. We may wonder if Rumphius smiled to himself when he wrote the words "niet zonder reden" in this sentence.

There were other kinds of *Accarbaar* or bastard corals which were known to the Malays in the time of Rumphius and used by them for medicinal purposes, but the *Accarbaar itam* or *Corallium nigrum* was regarded as the most important and was held in the highest esteem. Among these was the *Accarbaar puti*, which from the figure given by Rumphius was an Alcyonarian belonging to the family *Isidæ* and probably to the type genus *Isis*. This is of some special interest as the Mediterranean species of *Isis* was held in high esteem by the Mediterranean races in classical times, and was currently believed to represent the petrified hair of *Isis*. But that is another story, and one about which only the most fragmentary indications remain.

The task of identifying the various kinds of black coral mentioned by the ancient and later writers up to the end of the eighteenth century is extremely difficult, as detailed descriptions of the characters upon which the modern classification is based are almost entirely lacking. The substance was evidently black or brown in colour, it was capable of being bent or twisted when subjected to heat, and it was hard enough to be given a polished surface. Moreover, it may be presumed from various references that it was a product of the sea. It might have been, therefore, the Keratin axis of one of the *Plexauridæ*, of one of the *Gorgonidæ* or of one of the *Antipatharia*, or, finally, of *Gerardia savalia*.

The *Accarbaar itam* of Rumphius was probably a *Plexaurid*. The figure of the stript coral that Rumphius gives is not conclusive but quite consistent with this identification. In the description of the cœnenchym which covers the axis, when it is fresh, he uses the Dutch work *Schorse*, i.e. bark, whereas in the description of another *Accarbaar* which is almost certainly a *Gorgonid* he uses the word *Korste*, i.e. crust. In the description of a third *Accarbaar* which is obviously an *Antipatharian* he uses the word *Slijm*, i.e. slime. With such an accurate observer as Rumphius was, we may assume that the use of these different words for the cœnenchym signified a real difference in character between them. In the *Plexauridæ* the cœnenchym is relatively thick, in the *Gorgonidæ* it is almost invariably much thinner, whereas in the *Antipatharia* it is usually little more than a soft and delicate film covering the axis. This identification of the *Accarbaar itam* of Rumphius as a *Plexaurid* is consistent with Prof. Gardiner's identification of the bracelets obtained by Mr. Pownall in Java as the axis of *Plexaura*.

Rumphius states that the *Accarbaar itam* is not identical with Pliny's *Antipathes* because it does not give the smell or colour of myrrh on boiling in milk. For other reasons than this, however, we may feel certain that the *Antipathes* of Pliny and the earlier writers was not a *Plexaurid*. The evidence seems to point to the conclusion that the black coral commonly used by the ancients was the form mentioned by Imperato (1599) as *Savaglia* and now known to science as *Gerardia savalia*. (Until quite recently *Gerardia* was considered to be an *Antipatharian*, but it has now been definitely placed in the order *Zoanthidea*.) The reason for believing that it was *Gerardia* is that this coral grows in the Mediterranean Sea, whilst the *Plexauridæ* do not, that it attains to great dimensions (a great specimen in the British Museum being two metres in height and spreading fan-wise to a width of over two metres) and the surface of the branches is smooth and devoid of spines. It is possible that in addition to the *Gerardia* the main stem of some of the species of *Antipatharia* that are found in the Mediterranean Sea may also have been used. Gansius in his "Historia Coralliorum" (1666) describes a species, *Antipathes hirsutum*, found in the Sardinian seas which is in length greater than the human stature. The axis of such a specimen if polished would be difficult to distinguish from that of *Gerardia*.

The difficulty of determining the black coral of the ancients, however, is due to the possibility that they may have imported it from the South, in which case *Plexaurid* or *Gorgonid* coral may also have come into use. Thus Pliny says in writing on coral, *Nat. Hist.* xxxii. 11, "Gignitur et in Rubro quidem mari sed nigrus item in Persico—vocatur Jace—laudatissimum (i.e. red coral) in gallico sinu circa Stoechades insulas" etc. This passage indicates that the most valuable kind of coral known to the Romans came from the Îles D'Hyères and other places in the Mediterranean Sea, but a black kind was also imported from the Red Sea and the Persian Gulf, in which seas the *Corallium rubrum* is not found.

Black coral was also known to the Moors in early times, and was very probably obtained by the fishermen engaged in the famous red-coral fishery off *Marsa-al-Kharaz*, the modern *Bona* or *Bône* on the coast of *Algeria*. The Arabic name for black coral was "yasz" or "yusz," a word which seems to have some resemblance to Pliny's "jace."

These few notes on the use of black coral in early times may seem to be very fragmentary and inconclusive, but they may be, perhaps, sufficient to create some interest in and to stimulate further investigation in a chapter of zoological mythology which has not yet been written. It is probable that classical and oriental research will reveal a great many more references to this substance than are recorded in these notes, and it may be expected that the excavations of the antiquaries will bring to our collections some specimens of black coral that were used in ancient times; but I think there is sufficient evidence to prove that the belief in the magical properties of black coral is not only widespread at the present day but also carries with it the sanction of a tradition which has been transmitted from the early days of our Western civilisation.

## The Determination of Stellar Distances.

By Dr. WILLIAM J. S. LOCKYER.

IN his presidential address delivered before the Royal Astronomical Society, in connexion with the celebration of that society's centenary (see NATURE, June 24, p. 815), Prof. Eddington referred to six great landmarks of astronomical progress during that century. He pointed out that this was a record of advance which was *continuous*, and not in great waves followed by periods of exhaustion. As he further remarked, the centre of most rapid progress has shifted from time to time and the various branches of astronomy have had their ups and downs. In this second category may perhaps be placed the determinations of the parallaxes or distances of the stars, because quite recently a very great impetus has been given to this branch of astronomy by the introduction of a rapid and effective new method.

So long ago as 1837 the first successful attempt to determine the parallax of a star was accomplished by Bessel, who made his result known in the last month of 1838, showing that 61 Cygni had a parallax of about one-third of a second of arc. Since that date this research has been carried on continuously and we have now catalogues of the parallaxes of a large number of stars. Among the observatories measuring trigonometrical parallaxes to-day, may be mentioned Allegheny, Dearborn, Greenwich, McCormick, Mount Wilson, Oxford (Radcliffe), Swarthmore, and Yerkes, and these institutions secure material which provides about three or four hundred parallaxes a year.

It is interesting to note that in the early days it was thought that the brightest stars were the nearest to us, and therefore attempts were first made to determine their distances. It was soon found, however, that estimates of distance based upon apparent magnitude were wholly futile, for the greater number of the larger parallaxes determined were of stars of the fifth, sixth, and fainter magnitudes.

The work of measuring the parallax of a star may be considered one of the most delicate operations in the whole field of practical astronomy. There are three methods available. The *absolute* method consists in making meridian observations at different times of the year and then studying the resulting places after all known corrections have been made. The *differential* method may be classed under two sub-heads. The first consists in measuring the position of the star to be studied in relation to neighbouring stars at different times of the year. If the neighbouring stars in the field of view of the telescope be close to the star under examination, a wire micrometer is used, but if distant, the heliometer is the more efficient instrument. The second differential method utilises the sensitive plate and consists in photographing a star region at different times and eventually measuring the positions of the star in question in relation to the neighbouring stars.

It was not until the year 1914 that the spectroscopic method was applied to the determination of stellar distances, and the method now in use is that originated and developed by Prof. W. S. Adams and other astronomers at the Mount Wilson Observatory in California. It is based on the fact that the intrinsic brightness of a star

has an appreciable effect on its spectrum. Thus, if two stars have the same type of spectrum but differ greatly in luminosity they will probably differ greatly in size, density, and in depth of their surrounding gaseous atmospheres. If this be so, then their spectra should exhibit variations in the intensity and character of such lines as are peculiarly sensitive to the physical conditions of the gases in which they find their origin, in spite of the general correspondence between the two spectra. If, as Prof. Adams states, "such variations exist and a relationship can be derived between the intensities of these lines and the intrinsic brightness of the stars in which they occur, we have available a means of determining the absolute magnitudes<sup>1</sup> of stars, and hence their distances."

It has been found that certain lines in stellar spectra do give indications of variation with absolute magnitude,

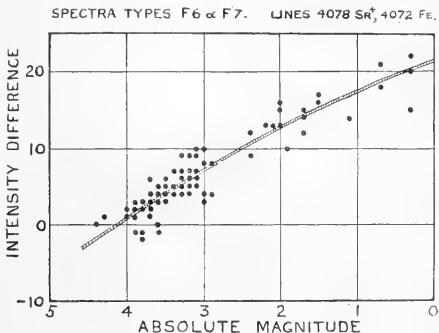

FIG. 1.

One of the fundamental curves formed from *known* parallaxes (black dots) of stars of spectrum types F6 and F7. When the intensity-difference in any star of these types has been determined, the absolute magnitude can be read off the curve and the parallax calculated.

and the detection of them we owe to Hertzsprung and Adams and Kohlschütter.

To determine the absolute magnitudes of stars any of three different sources of data can be utilised, namely, the trigonometrical parallaxes, parallactic motions, or proper motions. The most serviceable of these is the first, and reference to this alone will be made here.

The first step in the process is to have available a classification of star spectra based on detailed measurements of line intensities instead of on the more general eye estimations, estimations which have been extremely valuable up to the present time for the general classification of stars but are now superseded. Such a detailed classification for many of the brighter stars has been made and is being rapidly extended.

It is next necessary to construct a series of reduction curves for each type or class of spectrum or for small groups of types (see Fig. 1). These curves are based

<sup>1</sup> The absolute magnitude of a star is its apparent magnitude when reduced to unit distance. (Unit distance = Parallax of  $\sigma^3 \cdot 1$ .)

on the calculation of absolute magnitudes of stars as determined from the apparent magnitudes (which are known) and from the trigonometrical parallaxes (also known) obtained from one or other of the methods previously described. The equation for this computation is as follows :

$$\text{Absolute Mag.} = \text{Apparent Mag.} + 5 + 5 \log (\text{Parallax}).$$

Stars of the same type of spectrum but of different absolute magnitudes are then compared with one another and the relative intensities of selected pairs of lines carefully measured. Curves are then drawn showing as ordinates the observed differences of intensities for each selected pair of lines, and as abscissæ the absolute magnitudes.

With these data it is a simple matter to determine the parallax of any star. Thus, it is only necessary to (1) determine first its type of spectrum, (2) measure the differences of intensities of certain lines in it and refer these values to the curves for that type ; the next step is to (3) note from the curve the corresponding absolute magnitude, and lastly (4) determine the parallax from this absolute magnitude by means of the same formula as given above but arranged in a different order, thus :

$$5 \log (\text{parallax}) = \text{Absolute Mag.} - \text{Apparent Mag.} - 5,$$

in which all the members on the right-hand side of the equation are now known quantities.

Thus a single photograph of the spectrum of a star is sufficient for the determination of the star's distance. Naturally greater accuracy is obtained when more than one photograph is examined and several pairs of lines in them are used, but this involves very little extra labour.

The rapidity with which the determinations of parallax can be secured, when once the fundamental curves are formed, is far in excess of that of the older methods. The large, powerful instruments of the present day are capable of photographing the spectra of very faint stars, so that a rapid survey of the whole heavens, at any rate to stars of about magnitude 6.5, will be accomplished in the near future.

At the recent meeting of the International Astronomical Union in Rome, great attention was paid to organising this work on an international basis. The Parallax Commission pointed out that there is a large amount of latent information regarding stellar distances in the long series of spectrograms obtained for other

purposes at many observatories, and it is to be hoped that these data would be utilised.

A year ago the spectroscopic determinations of parallax were confined entirely to the United States at the Observatories of Mount Wilson and Harvard College. The Astrophysical Observatory at Victoria, B.C., now proposes to examine their slit spectrograms for this purpose.

In this country the only observatory occupied at present with this work is the Norman Lockyer Observatory at Sidmouth. For more than a year the large collection of spectrograms has been undergoing measurements in this connexion, and a large number of new photographs has been taken. An interesting point in this observatory's work is that the measurements of the intensity differences between pairs of lines are being determined by a method originated by the writer, which is different from either of those used at the American observatories. Thus an independent check on the American results is rendered possible.

It is necessary to point out, however, that this research on so large a scale could not have been undertaken had it not been for the opportune assistance rendered by the Department of Scientific and Industrial Research. This Department appointed Mr. W. B. Rimmer, D.I.C., in July 1921 as a research assistant, and his appointment was due to terminate towards the latter end of this year. It is with very great satisfaction that it may now be stated that it has been extended to September of next year. The work is so far advanced that now most of the fundamental curves are completed. It is hoped, therefore, to publish shortly the spectroscopic parallaxes of about 500 stars, followed after a short interval by another 500.

It is satisfactory, therefore, to record that in this new impetus given to the investigation of the distances of the stars, this country is taking a part, and it is hoped that other observatories here which have useful material will join in and discuss it from this point of view.

This line of research should also provide an interesting field of work for the amateur astronomer. The instrumental equipment required need be only on a moderate scale, for a five-inch telescope, fitted with a suitable prism, would meet the case, if a larger one were not available. It is a definite and straightforward piece of research which would be a valuable contribution to astronomy.

### Short-wave Directional Wireless Telegraph.<sup>1</sup>

By C. S. FRANKLIN.

**D**IRECTIONAL wireless telegraphy is by no means a new development, for Hertz made use of reflectors at the transmitting as well as the receiving ends in order to augment the effects, and to prove that the electric waves which he had discovered obeyed, to a considerable degree, the ordinary optical laws of reflection. Senatore Marconi, in his earliest endeavours to develop a telegraph system using electric waves, also employed reflectors to increase the range and get directional working.

The discovery by Marconi of the great increase of range obtained by the use of longer waves, and the earthed vertical aerial, practically stopped development on directional lines for the time being. The demand of the time was for increased ranges ; and as the first practical application of wireless telegraphy, namely, working to and between ships, required "all round" working, there was very little call for directional systems.

To-day the range has arrived at the maximum possible on the earth, and the wave-length has increased to such an extent that the frequencies pro-

<sup>1</sup> From a paper read before the Institution of Electrical Engineers on May 3.



posed are within or near to the limits of audibility. The possible gamut of wave-lengths is becoming very fully occupied, and although the development, during the last four years, of nearly pure continuous-wave transmitters, and of receivers with vastly improved selective powers has eased the problem, the time will soon arrive when the only way of increasing the number of possible services will be by employing systems having good directional characteristics.

There are, broadly, two general classes of directional aerial systems: (a) Those having the general characteristic that their directional power or polar curves are nearly independent of their dimensions. The directional result is obtained by opposing the effects of a number of aerials, or parts of an aerial with suitable phasing adjustments, the degree of opposition being a function of the direction. Systems of this class may be made small compared with the wave-length employed; for the purposes of position finding, and as receiving systems enabling interference to be eliminated from several directions, they have already been developed to a considerable degree. The simplest example of this class is the well-known frame aerial. (b) Those having the general characteristic that their directional power or polar curves depend on their dimensions relative to the wave-length employed. In this class the directional result is obtained by adding the effect of a number of aerials, or parts of an aerial, when working in the required direction. The underlying principle is that the effects, for the required direction, are integrated over a wide front in proportion to the wave-length. Such systems can, therefore, have small dimensions only when using short waves, and this fact makes their development difficult.

As examples of such systems may be mentioned—

- (1) Reflector systems in general.
- (2) Systems composed of lines of aerials, at right angles to the working direction, correctly adjusted as regards phase.
- (3) The Beverage long, horizontal receiving aerials.

The reflector system was the first tried for wireless telegraphy. The use of reflectors of reasonable dimensions, however, implies very short waves of the order of a few metres, and the very high attenuation of such waves over land or sea, and the difficulty of getting much power into them, tended to make early attempts very discouraging.

The investigation was commenced by Senatore Marconi in Italy in 1916, with the idea of developing the use of very short waves, combined with reflectors, for certain war purposes.

The waves used were 2 metres and 3 metres. The only interference experienced with such waves is from motor boats and motor cars, for these machines apparently emit waves from near 0 up to about 40 metres in length. A coupled-circuit spark transmitter was developed, the primary having an air condenser and spark in compressed air. By this means a moderate amount of energy was obtained, and the small spark-gap in compressed air proved to have very low resistance. The decrement of the waves emitted was judged to be of the order of 0.03. The receiver used was a carefully picked crystal, while the reflectors employed were made of a number of strips or wires tuned to the

wave, arranged on a cylindrical parabola with the aerial at the focus. The transmitting system was arranged so that it could be revolved and the effects studied at the receiver.

Reflectors having apertures up to  $3\frac{1}{2}$  wave-lengths were tested, and the measured polar curves agreed very well indeed with the theoretical curves. The use of two reflectors with apertures of  $3\frac{1}{2}$  wave-lengths, one at the transmitter and one at the receiver, increased the working range about 3 times.

These Italian experiments showed that good directional working could be obtained with reflectors properly proportioned with respect to the wave-length. The attenuation over sea for the wave-length used was found to be very high, and with the apparatus available the maximum range obtained was 6 miles.

The experiments were continued at Carnarvon in 1917. With an improved compressed-air spark transmitter, a 3-metre wave and a reflector having an aperture of 2 wave-lengths, and a height of 1.5 wave-lengths, a range of over 20 miles was obtained to a receiver without a receiving reflector. The experiments at Carnarvon brought into prominence a property of wave propagation which is not generally known, and the extent of which is not realised, namely, the very rapid increase in the strength of the electric field with height above the ground. The rate of increase appears to be a function of the height divided by wave-length, and while not very noticeable with waves of several hundred metres, is very marked with waves of a few metres' length.

It was found that the limiting range at sea level and over sea was 4 miles. When both transmitter and receiver are at a low level the range is very dependent on the nature of the intervening country, and is very restricted even over sea; when, however, both stations are many wave-lengths above the intervening country its nature is of far less importance, and the range is increased many times. These experiments showed that very considerable ranges were possible with very short waves.

In 1919 experiments were commenced at Carnarvon with valve transmitters, with the idea of producing a directional telephone system. A wave of 15 metres was selected, which while well within the capacity of the power valves available, allowed a simple reflector to be used without too large a structure. After some trials a single valve transmitter was arrived at taking about 200 watts with a 15-metre wave, and giving 1 ampere in the centre of a half-wave aerial. A heterodyne receiver with supersonic beat-note was employed. Finally, very strong speech was obtained at Holyhead, 20 miles away. The strength was such that shadows produced by small hills and buildings were scarcely noticeable unless the stations were close behind them.

The next point was to test the maximum range, and particularly to find whether such waves would carry over the horizon, and whether there would then be a rapid falling off of strength. Tests were carried out with the Dublin Steam Packet Company's boats running from Kingston to Dublin in June 1920, and speech was received in Kingstown Harbour, 70 nautical miles from Carnarvon, and the point was proved that there

was no rapid diminution of strength after passing the horizon line from Carnarvon.

The range of the system was also tested wholly over land. A site was chosen at Hendon, and a reflector and transmitter for 15-metre waves erected with the reflector pointing towards Birmingham. Tests were commenced in February 1921 from Hendon to a portable receiver on a motor car. Very good speech was received up to 66 miles, and fair speech in the neighbourhood of Birmingham. A reflector station was then erected at Frankley near Birmingham, 97 miles from Hendon, and tests were started there in August 1921.

Measurements with and without the reflectors indicate that the energy received when both reflectors are up is about 200 times the energy received when not using the reflectors. Local measurements of the polar curves taken round the station show that the electric field in front of the station is increased approximately 4 times by the use of the reflector, and that the same order of increase is obtained during reception; the increase of energy received due to the use of the two reflectors should therefore be  $4^2 \times 4^2 = 256$  times.

During the continuous-wave tests at Carnarvon it was found that reception was quite possible on the transmitting aerial while the transmitter was operating. The heterodyne may be either the transmitter, or an independent small heterodyne in the receiver. Both the transmission and the reception utilise the same aerial and reflector, and the transmitter is left going and can be operated while receiving.

There is no reduction in strength while the transmitter is on, but a practical trouble has appeared. Owing to the comparatively large power, strong currents are induced in all conducting structures and circuits close to the reflector and transmitter, such as the supporting towers and buildings, and every variable contact produces a noise. The elimination of all variable contacts in the neighbourhood of the transmitter has proved a work of some magnitude.

Reflectors besides giving directional working, and economising power, are showing another unexpected advantage, which is probably common to all sharply directional systems. It has been noted that practically no distortion of speech occurs, such as is sometimes found with non-directional transmitters and receivers.

Although the results between Hendon and Birmingham constitute a record for telephony for ratio of range to wave-length—for such results were believed to be impossible two years ago—they are only a first attempt and do not represent the best that can now be done after the experience gained. But it has been demonstrated that wave-lengths of the order of 20 metres are capable of providing point-to-point directional commercial service over very considerable ranges. Such services will be comparatively secret as compared with the usual non-directional type of transmission.

The directional effect obtained with reflectors which are large compared with the wave-length is so good that it was suggested that it would prove very useful for position finding for ships near dangerous points.

The general idea is that a transmitter and reflector revolving will act as a kind of wireless lighthouse. It

is not intended at present for long ranges, but rather that revolving reflectors should be erected in position, similar to those at present occupied by fog signals, and be capable of similar ranges, so as to give the position to ships during fog when within about 10 miles of the danger point.

An experimental revolving reflector was erected on Inchkeith, and tests were made to *s.s. Pharos*, the lighthouse tender of the Northern Lights Commissioners during the autumn of 1920. With a 4-metre wave, spark transmitter, a reflector of 8 metres' aperture, and a single valve receiver on the ship, a working range of 7 nautical miles was obtained. The reflector made a complete revolution once every 2 minutes, and a distinctive signal was sent every half-point of the compass. The bearing of the transmitter could then be determined within  $\frac{1}{4}$  point of the compass, or within 2.8 degrees.

The best method of giving the direction to a ship by means of such a revolving beam requires consideration. When listening in a receiver to a moderately sharp revolving beam the signals are heard only for a very short time. The exact time of maximum signals is not easy to determine by ear, but the times of starting and vanishing are easy to determine, as the rate of rise and fall of the signals is extremely rapid. The time half-way between these two times gives with great exactness the moment when the beam is pointing to the ship.

It would be quite possible to arrange to send a general broadcast signal when the beam passes through true north; then by arranging for the beam to revolve at a perfectly uniform rate, the bearing on the ship could easily be determined by means of a stop-watch. This method is probably the most accurate, but has some disadvantages. It entails accurate timing mechanism at the transmitter, the use of two waves, and three, or perhaps four receivers on the ship, as well as the use of a stop-watch.

For the short wave two receivers are required, one at each end of the bridge, or one fore and one aft. This is necessary to avoid screening by the ship itself. If the broadcast wave for giving the time when the beam passes true north is another short wave, then two more receivers would be required.

The method provisionally adopted avoids accurate timing mechanism at the transmitter and the use of a broadcast wave. On the base of the revolving reflector contact-segments are arranged so that a definite signal is transmitted every half- or quarter-point of the compass.

The apparatus proposed is of a very sturdy nature. The spark transmitters are robust, and last for years without attention. The receivers are simple valve rectifiers with fixed adjustments except for a "backing off" potentiometer for dealing with powerful signals at close range. The attenuation of these waves over sea is so strong that a little experience enables distance to be judged by strength of signals, and this can be measured by means of the potentiometer. The only qualification necessary for a person determining the bearing is the ability to read a few Morse signals.

The success of the present experiments indicates a wide sphere of usefulness for the new short-wave directional wireless system.

## Obituary.

PROF. W. WISLICENUS.

BY the death, on May 8, of Wilhelm Wislicenus, professor of chemistry at the University of Tübingen, organic chemistry lost one of its most fruitful research workers, who contributed in no small measure towards placing the science on the basis which it now occupies. He was born at Zürich on January 23, 1861, and was the eldest son of Johannes Wislicenus, that great organic chemist whose name stands on the roll of fame co-equal with those of Hofmann and Frankland. At the time of Wilhelm's birth his father, who had, in the previous year, moved from Halle to Zürich, where he had married Katherine Sattler, the granddaughter of Wilhelm Sattler, joint discoverer of "Schweinfurt green," held the chair of chemistry and mineralogy under the council of the Canton at the School of Industries. Wilhelm may be said, therefore, to have inherited his chemical genius both on his father's and mother's sides.

W. Wislicenus received his early scientific training at the University of Würzburg, to which his father had moved, in succession to Adolf Strecker, in 1872, and it was from here that he published his first paper, "On a New Reaction between Potassium Cyanide and Phthalide," a reaction which he was able to prove to be of general application, and which he applied to a number of other lactones with fruitful results. In 1885 his father succeeded Kolbe at Leipzig, but Wilhelm continued to work at Würzburg, and thereafter, until 1903, he published a series of important communications from these laboratories. In this year he removed to Tübingen, where he continued to work until shortly before his death.

The earlier work of Wilhelm Wislicenus is intimately associated with the behaviour of metallic sodium towards organic esters, a problem towards which the attention of many chemists of his time was directed, and in connexion with which his father had already published his epoch-making paper, dealing with ethyl acetoacetate and its application as a synthetic agent, in the "Annalen" of 1877. Indeed, we are told by W. H. Perkin in his Johannes Wislicenus memorial lecture that the laboratory at Würzburg was, during the early 'eighties of the last century, busily engaged in carrying out syntheses by the aid of ethyl acetoacetate and ethyl malonate. It is not surprising, therefore, that the young Wislicenus should have followed the general trend, and that one of his earliest papers, published from Würzburg in 1886, should have dealt with the interaction of metallic sodium on a mixture of ethyl acetate and ethyl oxalate, as an outcome of which he was able to discover ethyl oxalyl-acetic ester. Wislicenus at once realised the importance of this discovery, and he was able later, both by himself and in association with his co-workers, to apply the new reaction to the preparation of a large number of  $\alpha$ -ketonic esters, and, indeed, our knowledge of these important substances is mainly due to him.

About this time, also, the general question of the movement of a hydrogen atom from carbon to oxygen, as illustrated by the behaviour of ethyl acetoacetate,

and the co-ordination of this phenomenon with others, notably that exhibited by hydrocyanic acid, was receiving considerable attention, and, in 1885, C. Laar published his famous hypothesis in which he coined the word "tautomerism." Laar imagined oscillatory conditions within the molecule which caused the hydrogen atom to take up one or other position alternately. He therefore presupposed the simultaneous existence of both modifications, or, in other words, he considered that the phenomenon was intra-molecular and not inter-molecular. Even at the present time this problem is by no means solved, and it cannot yet be said that Laar was not right in regarding the basis of change as intra-molecular. Still, there is no doubt that, in one of its aspects, the Laar hypothesis did not provide for the existence of the tautomeric individuals, and it was, initially, due to W. Wislicenus that, in this restricted sense, the hypothesis was shown to be wrong. The discovery of the existence of two forms of ethyl formylphenylacetate was made by W. Wislicenus in 1887, during his experiments on the action of sodium on mixtures of organic esters. Earlier in the year Piutti had shown that when a mixture of ethyl acetate and ethyl formate was used in this reaction the expected ethyl formylacetate was not produced, or if produced, at once underwent inter-molecular condensation yielding the aromatic compound trimesic ester. In order to avoid this, Wislicenus replaced the ethyl acetate by ethyl phenyl acetate and obtained the open chain formyl esters. He showed that the two esters he isolated were distinct substances, one a liquid giving pronounced enol reactions, the other a solid which possessed the characteristic properties of the keto modification. Since that time many examples of the same kind have been recorded, several of which have been discovered by Wislicenus and his pupils. The whole question is summarised in a lecture given by him at Leipzig in 1897, embodied later (1898) in one of the Ahrens' Sammlungen, in which he clearly enunciates his view that tautomeric phenomena are reversible isomeric changes. Prior to this, in a paper published in the *Berichte* for 1895, the following passage occurred: "Über die Natur der Isomerie ist eine Entscheidung wohl erst nach ausführlicheren Untersuchungen zu treffen, wenn es mir auch am wahrscheinlichsten zu sein scheint, dass hier die beiden Aldehyden, Ketonen, und  $\beta$ -Ketonsäureestern vermisste tautomeren Formen vorliegen"; a view which was to receive full verification in the later work of Kurt Meyer and Knorr.

Wislicenus continued to work on the general question of tautomeric change for many years after this, and in 1912 he published a further paper in the *Annalen* dealing with the chemistry of ethyl formylphenylacetate. By that time four isomeric modifications had entered the field, but, in the paper quoted, he strongly expresses his view that only two of these, namely, the liquid  $\alpha$ -form (enol) and the solid  $\gamma$ -form (M.P. 100°, enol-aldo), are chemical individuals. The  $\beta$ -form (M.P. 70°) and Michael's modification (M.P. 50°) he regards as mixtures of the  $\alpha$ - and  $\gamma$ -forms. In 1916, in a paper also published in the *Annalen*, he describes the two forms of the methyl ester of phenyl-

formylacetic acid, both of which are solid, and discusses the curious property of the  $\beta$ -form of combining with methyl alcohol.

It was not, however, in this field only that the experimental skill and keen insight of Wislicenus found scope. His activities in other branches of the science, too numerous to mention in a short monograph such as this, find expression in upwards of one hundred communications, published chiefly in the *Annalen* and in the *Berichte*. Nevertheless, some of these cannot be passed over without comment. For example, in 1892 he discovered a new and simple method for the preparation of hydrazoic acid by causing ammonia and nitrous oxide to react in the presence of sodium. Later, in 1905, in conjunction with Otto Dimroth, he utilised the sodium azide thus formed for the preparation of the simplest organic azide, methylazide ( $\text{CH}_3\text{N}_3$ ), by causing it to react with methyl sulphate.

One of the most frequently occurring phenomena met with during the course of organic chemical reactions is that which involves the movement of groups, such as the hydrocarbon radicals, from one element to another, a change which appears to be closely related to that which is associated with the movement of a hydrogen atom within a tautomeric system. Numerous well-known reactions, such as, for example, the Hofmann synthesis of primary amines, the Beckmann rearrangement, and so forth, involve a transference of this kind, and it is, therefore, of interest to note that Wislicenus was able to discover certain typical examples of the migration of an alkyl group from oxygen to nitrogen, and to study the conditions under which the change occurred. Thus, in 1900, he showed, in conjunction with M. Goldschmidt, that phenylforminoethyl ether,  $\text{OEt} \cdot \text{CH}=\text{NPh}$ , is converted, to the extent of about 40 per cent., into the isomeric methylformanilide, when it is heated at  $230\text{--}240^\circ$ . Later he was able to prove that the C-methyl ether of caffeine is readily converted into the N-methyl derivative.

Wilhelm Wislicenus was the distinguished son of a distinguished father. His name will always occupy a foremost place in the front rank of the organic chemists of his time.

J. F. T.

DR. A. G. MAYOR.

THE death of Alfred Goldsborough Mayor, at the comparatively early age of fifty-four, deprives the scientific world of a worker whose experience in tropical marine biology was unrivalled. Mayor stood in the direct historical succession of American participation in this field, for as the mantle of Louis Agassiz fell on his son Alexander, so did Alexander's mantle fall on the shoulders of Alfred Mayor, who accompanied him as assistant on many of his wanderings in the Pacific. When, in 1904, Mayor was appointed director of the Marine Biological Department of the newly founded Carnegie Institution of Washington, he really entered into his inheritance, and though so many of the projects of his fruitful brain will never mature, the work which has been accomplished at his laboratory in the Tortugas, Florida, and during many expeditions, forms his imperishable monument.

This laboratory, where Mayor died on June 24, is situated at the southernmost point of the United

States, 70 miles west of Key West, on a tiny island (Loggerhead Key) which is surrounded by the purest ocean water. It was selected for this especial reason, for Mayor felt that nowhere else in Florida could the proper conditions for the experimental investigation of marine animals be secured. The position is not without disadvantage, and it is generally considered advisable to close down for the autumn hurricane season and for the winter, during which Mayor carried out his expeditions to other seas and islands. The Tortugas Laboratory was generally only available between early May and the end of July. This, however, is the most suitable time for the university research workers of the United States, from whom Mayor drew his investigators by personal invitation. These invitations, to work free of all expense and with payment of travelling expenses, were freely issued to all those whom he felt had some problem which could be favourably attacked at the Tortugas, and until that problem was, as nearly as possible, solved, no pressure embarrassed the research, but season after season it was his custom to reinvoke those who had studied with him before and put in their way opportunities which he felt they might have missed before.

The success of his policy is to be seen in the splendid list of researches which stands to the credit of the Tortugas Laboratory. His own publications range widely over systematic zoology ("The Medusæ of the World," published in 1911), comparative physiology (especially the series of studies on the jelly-fish *Cassiopea*), the physicochemical properties of oceanic water, and biological problems like the growth rate of corals, and reflect his many-sided personality and his abounding energy. The work of his colleagues in whatever subject shows his direct interest and influence and the pains which he took to provide the most complete and satisfactory equipment. Whatever novel line of investigation was likely to throw light on marine work was certain of his most enthusiastic co-operation, and in this connexion may be mentioned the encouragement given to workers on the bacteriology of sea-water, like Harold Drew and Lipman, and the development of scientific under-water photography by W. H. Longley.

The expeditions which Mayor organised and carried out are too numerous to mention, but those to Murray Island, on the Great Barrier Reef, in 1913, and to Tutuila, in American Samoa, in 1915-20, really broke fresh ground in the investigation of tropical marine faunas. At both places he made an intensive study of the coral reefs and was able to demonstrate certain very interesting relations between the physiological characteristics of the different reef corals and their position and development on the reef. These and many other problems of importance were attacked by Mayor and his co-workers, but all the results are not yet published.

Mayor was as faithful in friendship as he was fascinating as a companion. The energy and vitality of his body and mind, his dramatic sense, the tenacity of his memories of men and countries, the range and grasp of his knowledge, all never failed to rouse the admiration of his friends. Something has been said of the zeal with which he furthered the efforts of those who worked with him. It could even be stated that

he endangered the success of his own researches by the readiness of the aid he rendered to others.

Mayor cherished a great ambition to remove the equipment of the Tortugas Laboratory to some locality in the West Indies and make it a truly international meeting-place for biologists. Just before the war his opportunity seemed to have come, and he was about to enter into negotiations for a site in Jamaica when the storm broke. It was a bitter disappointment to Mayor that he was not able to proceed with his project after the war, not least because he hoped that, in his yearly assemblies, English biologists would be represented more fully than in the past, and that in this way the cause of Anglo-American unity, which he held very dear, would be furthered.

F. A. P.

#### DR. ALEXANDER GRAHAM BELL.

ON August 1 Dr. Alexander Graham Bell, one of the world's greatest inventors, died at the age of seventy-five years. The effects of early upbringing and environment always leave their mark on a man's life, and in Graham Bell's case they are specially apparent. His father spent the first half of his life as a lecturer on elocution at Edinburgh, and was also a prolific author of books on the same subject. Among his son's earliest experiments were the recording of speech waves on smoked cylinders. Graham Bell was a student at Edinburgh University, and later he assisted his father when the latter was a lecturer at University College, London. In 1870, for reasons connected with Graham's health, the family migrated to Brantford, near Tutela Heights, Ontario. In 1873 Graham was appointed professor of physiology at Boston University. In 1874 he invented a system of harmonic multiple telegraphy, and in that year he began a series of experiments which led him at last to realise in practice his conception of an articulating telephone.

Considering the marvellous results achieved the mechanism of the telephone is wonderfully simple. Previous to its invention, elaborate devices had been proposed containing large numbers of tuned reeds so as to cover the whole gamut of the human voice. The final form of the instrument is fully described in Graham Bell's patents of 1876 and 1877. Although he made several other notable inventions, the telephone will always be outstanding as his supreme achievement. It first attracted world-wide attention at the Centennial Exhibition in Philadelphia in 1876. After Graham Bell had laid down all the essential principles of telephony, Edison developed his carbon transmitter.

In 1878 the first telephone exchange was established. There are now about twenty-one million telephones connected with the various exchanges throughout the world. In the early days Graham Bell regarded twenty miles as the limit to which articulate speech could be sent. It has now been sent over five thousand miles.

In 1917 the Bell Memorial Committee presented to Brantford, Ontario, a public park, the house in which Graham Bell lived when he made his epoch-making discovery, and a noble monument, to commemorate the invention of the telephone. Graham Bell in his later years took the keenest interest in aeronautics and geophysics. When Father Cortie recorded the mag-

netic storm of August 11, 1919, in NATURE (vol. 103, p. 483), Graham Bell wrote to say that he had noticed a display of the Aurora Borealis at Cape Breton Island on that date, "Pulsations of light swept upward to the zenith resembling clouds driven before a heavy wind" (vol. 104, p. 74). He was made a doctor of science at Oxford in 1906, and in 1913 the Royal Society awarded him the Hughes medal and the Institution of Electrical Engineers made him an Honorary Member. On his visit to this country in 1920 the freedom of his native city of Edinburgh was conferred on him. He was held in universal esteem. As the founder of a great and flourishing industry which ameliorates the conditions of life he was a great benefactor to humanity.

A. R.

WORKERS in many branches of science and education will deeply sympathise with Prof. W. A. Bone, professor of chemical technology in the Imperial College of Science and Technology, on the death of his wife on July 26. Before her marriage to Prof. Bone in 1916, Mrs. Bone, who was then Miss Liddiard, was headmistress of the St. Albans High School for Girls, and had previously been a member of the teaching staff of the Ladies' College, Cheltenham. She was a graduate in arts of the University of London, and possessed exceptional capacity for teaching as well as for organisation. While she was head of the St. Albans High School, the domestic economy school was inaugurated there. Mrs. Bone took an active interest in science progress in general, and her husband's researches in particular, and her death will be regretted by a large circle of pupils and friends who came under her strong and delightful influence.

ORIENTAL learning has suffered a serious loss by the death, at the age of eighty-five years, of Mr. Charles Henry Tawney, C.I.E. Educated at Rugby and Cambridge, where he gained the highest classical honours, and a fellowship at Trinity College, Mr. Tawney joined the Indian Educational Service, and became professor at the Presidency College, Calcutta, where he won the esteem of his pupils by his kindness and learning. He became Director of Public Instruction in Bengal, and retired from the Educational Service in 1892. On reaching England he became librarian at the India Office. Much of his time was occupied in assisting writers on Indian subjects, by whom he was regarded with the greatest esteem. He was an admirable Sanskrit scholar, and published several works, the best known of which are translations of two great collections of Indian folk-tales, the Katha Sarit Sagara and the Katha Kosa, enriched with valuable notes, which displayed a wide knowledge of the literature of folk-tales. One of his sons, Mr. R. H. Tawney, Fellow of Balliol, is a distinguished writer and lecturer on economic problems.

We regret to see the announcement of the death, on July 25, of Dr. Arthur Ransome, F.R.S., lately professor of public health in Owens College and examiner in sanitary science in the Universities of Cambridge and Manchester.

## Current Topics and Events.

THERE appears to be solid ground for accepting as an accomplished fact the arrangement which was first rumoured in this country about a year ago. In its annual report, the Compagnie Nationale des Matières Colorantes, the French equivalent of the British Dyestuffs Corporation, declares that "all who understand the complexity of the manufacture of organic colouring matters will realise why we have been compelled to acquire the patents, the processes, and the technical aid of our principal foreign competitors for exclusive use in France." This passage has been taken by the French press as the official description of an agreement between the Compagnie Nationale and the Interessen Gemeinschaft, by which detailed technical assistance and full information regarding processes of manufacture shall be supplied to the French factories by their German rivals, such technical assistance taking the form of German chemists to supervise operation of processes in the French dye-works. In return for these advantages, the consumption of French dyes would be limited to France and her colonies, whilst the profits arising therefrom would be shared by the Interessen Gemeinschaft. Although a superficial view of this plan may not be flattering to national *amour propre*, the arrangement is an eminently practical one. The plain English of it is that a fifty years' start cannot be overtaken in fifty months. The Allies are agreed in declining to trust Germany with a virtual monopoly in dyestuffs manufacture such as she enjoyed before the war, in the first place owing to its military potentialities, and secondly, though not less forcefully, because a flourishing dyestuffs industry offers the most powerful stimulus to encouragement of national talent in the field of organic chemistry—a branch of science which civilised countries cannot afford to neglect. Consequently, it has appeared to the French better to enlist the assistance of Germans in building up a domestic industry than to incur the terrible risks of not having any dyestuffs factories at all. The course which they have chosen may perhaps, in a somewhat modified form, suggest an avenue of escape from British embarrassments in the same industrial domain.

A DEPUTATION from the People's League of Health, which recently waited on the Parliamentary Secretary to the Minister of Labour, in order to direct attention to the effect of unemployment and the unemployment insurance benefit on the health and habits of the nation, referred *inter alia* to the subject of nutrition. Sir Bruce Bruce-Porter said that the amounts paid by way of unemployment benefit were insufficient to keep the worker fit, that the latter was frequently unversed in food values, and would be better able to render good service when trade revived were he able to obtain a standard balanced diet by means of food tickets in part substitution for unemployment benefit. This point is of considerable importance, and although, as urged by the Parliamentary Secretary, there are serious administrative difficulties in

the way of any such rationing scheme, we are of opinion that it ought to be considered seriously. The quantitative aspects of the problem of national nutrition need much more attention; we still have very little exact knowledge of the requirements of different classes of manual workers, and the foundations laid during the crisis of the war have not been built upon. We are glad to know that a strong committee, under the chairmanship of Prof. E. P. Cathcart, has been appointed by the Medical Research Council to examine the whole subject, and if possible undertake special research work. The food requirements of soldiers have been ascertained by exact experiment; the work of Cathcart and Orr in this field has been of the greatest value. The application of the experimental method to workers not under military discipline is difficult, while inferences from family budgets are frequently dangerous. However, a combination of the experimental method, applied to a relatively small number of selected individuals, and the statistical method of reducing budgets, will almost certainly lead to a solution of the problem. Similar remarks, of course, apply to the case of institutional dietaries—a subject under the consideration of a committee appointed by the Board of Control. It is doubtful whether the diets approved by various hospital and school committees are really based on any uniform scientific principles.

FROM the Royal Institute of British Architects we have received a notice of the preparations being made to celebrate the bi-centenary of the death of Sir Christopher Wren, who died on February 25, 1723, at the age of ninety-one years. The Royal Academy, the Royal Society, the British Museum, the London County Council, and other important public bodies are represented on the grand committee which has been formed, and the proposal is to have a commemoration week, beginning on Monday, February 26, 1923. The programme includes a memorial service, an exhibition, a pageant, and visits to Wren's buildings. Besides St. Paul's—the choir screen of which bears the oft-quoted inscription, *Si monumentum requiris circumspice*—Wren built about fifty City churches, and to him are also due the library of Trinity College, Cambridge, the Ashmolean Museum, Oxford, and Greenwich Observatory. Had Wren's career not been diverted to architecture, it is probable he would have been among the greatest scientific men of his age, such as Newton, Huygens, and Leibnitz. As a youth at Oxford he displayed remarkable ability, and gained the friendship of Wilkins, Boyle, Seth Ward, and others. In 1657, at the age of twenty-five, he succeeded Rooke as professor of astronomy in Gresham College, London, and three years later returned to Oxford as Savilian professor of astronomy. He was one of the founders of the Royal Society, and was president in 1680-81. Soon after being chosen Savilian professor he was given the sinecure post of assistant surveyor-general under Sir John Denham. The study of architecture,

however, soon engrossed him; in 1665 he spent much time in Paris, where Bernini was building the Louvre, and the great fire of London gave him an opportunity such as has fallen to few men. Estimating the damage done by the fire at over ten million sterling, Wren drew up an elaborate plan for rebuilding the city with wide thoroughfares and open spaces, and was appointed "surveyor-general and principal architect for rebuilding the whole city."

DR. J. S. FLETT, Director of H.M. Geological Survey, will act as one of the delegates of the Geological Society of London at the International Geological Congress at Brussels on August 21 to September 3, in place of Prof. W. W. Watts, who is unfortunately unable to proceed to Brussels for the congress. The other delegates nominated by this society are Prof. E. J. Garwood, Vice-President, and Dr. J. W. Evans, F.R.S.

THE National Research Council of Japan has issued the first number of a new periodical, *The Japanese Journal of Geology and Geography* (Tokyo, 1922), which illustrates once more the wide outlook of science in Japan. In this number all the papers are in English; they include one by Prof. Hayasaka recording for the first time the discovery of marine Lower Carboniferous strata in Japan, and one by Dr. Niya, with admirable photographic illustrations, on the mud volcanoes of Mimbu, Burma. The abstracts of papers published in Japan form an especially valuable feature, since they are given in English or German, almost all in English, and serve to make known a wide range of researches published originally in the national language.

DR. MICHAEL GRABHAM has gone to Porto Santo, the northern island of the Madeira group, to study the conditions under which the local race of Portuguese inhabitants are said to enjoy complete immunity from dental caries. These people possess huge, ugly, yellow, but sound teeth, and Dr. Grabham proposes to bring specimens to London. The recent discovery that Porto Santo, which is almost bare of vegetation, has a desirable climate of its own and, moreover, a valuable spring of mineral water, is leading to the incursion of Madeira migrants, and it will be instructive to observe how contact with these new-comers will affect the tooth immunity which Dr. Grabham is investigating. Valuable knowledge may be thus obtained of a malady which in this country has become a national problem.

A PROVISIONAL programme has been issued for the autumn meeting of the Iron and Steel Institute, to be held on September 5-8 at York, under the presidency of Mr. F. Samuelson. A number of papers have been promised on subjects which, although within the range of the Institute's activities, are of varied character and give promise of an interesting meeting. Among the topics which will be dealt with are the changes in properties of steels during heat treatment, modern blast-furnace practice, moulding sands, high-speed steel as well as testing and works machinery. Arrangements have been made for members of the Institute to visit the works of the Staveley Coal and Iron Co. Ltd., near Chesterfield, and of the

Parkgate Iron and Steel Co. Ltd., and there will also be excursions to places of interest in the neighbourhood of York. The secretary of the Institute would be glad to hear before August 15 from all who propose to attend the meeting.

It is announced that proposals for closer operation amongst the leading engineering institutions, which have recently been under consideration, have now received the approval of the institutions, the representatives of which met in conference, namely, The Institution of Civil Engineers, The Institution of Mechanical Engineers, The Institution of Naval Architects, and The Institution of Electrical Engineers, and that an engineering joint council composed of representatives of these bodies has been formed. Among the objects of the joint council will be, to improve the status of engineers, to secure the better utilisation of their services in the country's interests and the appointment of properly qualified individuals to responsible engineering positions, and to prevent the unnecessary duplication of activities. It is anticipated that, at a later stage, the number of bodies represented on the joint council may be increased, but this at present remains a matter for future consideration for the joint council and the institutions concerned.

WE have received from the American Bureau of Standards, Washington, Scientific Paper No. 437, on the solubility of dextrose in water. It is shown from cryoscopic measurements that at temperatures below 90° C. three solid phases can exist—ice,  $\alpha$ -dextrose monohydrate, and  $\alpha$ -dextrose. The hydrate is stable between -53° C. and 50° C., and has a very high temperature coefficient of solubility. Copies of this paper may be obtained on request to the Bureau of Standards. From the same source we have also received Scientific Paper No. 435, on metallographic etching reagents for copper alloys, nickel, and the  $\alpha$ -alloys of nickel, copies of which may also be obtained on application.

THE latest catalogue (No. 434) of Mr. F. Edwards, 83 High Street, Marylebone, W.1, is devoted to works on voyages, travels, exploration, and adventure in all parts of the world. The catalogue contains nearly 1300 titles. Many rare volumes are listed, including "The Antarctic Voyage of the *Erebus* and *Terror*," under the command of Capt. Sir C. J. Ross, 1839-43—The Botany and Zoology of the Voyage, by Sir J. D. Hooker, Sir J. Richardson, J. E. Gray, R. B. Sharpe, A. Günther, and others; and Gabriel Thomas's "An Historical and Geographical Account of the Province and Country of Pensilvania and of West-New-Jersey in America," 1st edition. There is also a set of the "Journal and Proceedings of the Royal Geographical Society of London" from 1830 to 1919.

A LIST of the new books and new editions added to Lewis's Medical and Scientific Circulating Library during April, May, and June has just been issued. It is carefully classified and should be very useful for reference. Copies can be obtained free of charge from the publishers, H. K. Lewis and Co., Ltd., 136 Gower Street, W.C.1.

## Research Items.

**THE ORIGIN OF THE SWASTIKA SYMBOL.**—The subject of the origin of the Swastika symbol has given rise to protracted controversy. The latest contribution to the question is that of Harit Krishna Deb in the *Journal of the Asiatic Society, Bengal*, 1921, No. 3. He suggests that it is a modification of the mode of expressing the ancient Hindu syllable Om, which is used in religious rites. This, a pothook with square ends, was duplicated, one across the other, to form the Swastika, meaning "bringer of blessings," which goes back in India to the seventh century, when it was used as a cattle-mark. Another reference is well before 528 B.C. It is found on gold leaf on a vase with relics of Buddha, and it appears on the Edicts of Asoka (273–232 B.C.). The earliest example known is on a spindle whorl from the third city of Troy, about 1800 B.C., and it is frequent in Greek vases about 600 B.C.

**INDIAN PAINTING AND MOHAMMEDAN CULTURE.**—The subject of Indian painting has recently attracted increasing attention, and its relation to Culture was discussed by Sir T. W. Arnold in the Sir George Birdwood Memorial Lecture recently delivered before the Royal Society of Arts. He illustrated its relation to Hinduism and Islam in the drawings of Musalman saints and Hindu ascetics; the etiquette of the Mughal Court and of social life, mainly derived from Persia; in the pictures of singers and dancers; of drinking bouts and feasts, and in the short-lived renaissance of Indian painting at the time when the Empire was breaking up. The importance of study of the subject, which would need a series of monographs, was emphasised by Lord Peel, the Secretary of State for India, and by Lord Ronaldshay, late Governor of Bengal.

**SPAIN AND IRELAND.**—In a lecture recently delivered before the Celtic section of the Société Internationale de Philologie, Sciences, et Beaux-Arts, London, Dr. W. Edmington Scott discussed the prehistoric relations between Spain and Ireland. He pointed out that the history of Iberian names for iron, lead, copper, tin, silver, mercury, gold, and several technical mining and metallurgical terms supplied evidence of long-standing trade communications between Spain and the Minoan and Ægean nations. Their presence in Old Irish pointed to Spanish intercourse with that island. The Phœnician exploitation of the Spanish mines lasted for nearly a thousand years, and it is possible that through these traders and colonists the Andalusian Basque names of the ores were introduced into Assyrian, Aramaic, Hebrew, and other Semitic languages. Tin ore was a necessity for the manufacture of bronze, and this undoubtedly came from the Cassiterides. The analysis of prehistoric Mycænean, Cretan, and Trojan bronzes proved that they contained a high percentage of tin, whereas Homeric bronze was much weaker. This was due to the scarcity of tin, resulting from the cutting by the Phœnicians of the ancient trade route between Greece and Spain, and the consequent diversion of the mineral resources of the Peninsula to Western Asia.

**HEALTH AND WEIGHT TABLES.**—Two charts have been prepared by the director of the Galton Laboratory, Prof. Karl Pearson, which should prove of great value to those in charge of infant welfare centres and clinics ("Health and Weight Probabilities," Cambridge University Press, 7s. 6d.). The purpose of the charts is to compare the weight of an individual baby with the average at its age and to give a rough estimate of its chance of surviving the first year of life. Thus, suppose a female baby weighs 10 lbs. at the end of

36 weeks; according to the chart, 97 per cent. of females aged 36 weeks weigh more than 10 lbs. (the chart has been constructed from numerous data of working-class infants), and at the end of the year 74 per cent. of all babies will be healthier than this one. Of course, as Prof. Pearson has pointed out, predictions based upon a single character such as weight are not of a high order of accuracy, but these charts will be very useful. It will be easy to see whether an infant is maintaining or improving its grade of weight and health.

**TURBINOID BONES OF NOTOTHERIUM MITCHELLI.**—H. H. Scott and C. Lord have succeeded in recovering about one-half of the maxillo turbinals of *Nototherium mitchelli* (Studies in Tasmanian Mammals, No. vii., Papers Roy. Soc. Tasmania, 1922). Their general structure is akin to that of the turbinal of a wombat, but their coarseness of texture is about twice that which obtains in the living kangaroos. In being straighter, and more cuneiform in shape, the maxillo turbinals of the *Nototherium* approach those of the kangaroos and depart from those of the wombats. By reason of their more extensive vertical plates, they approach those of the wombats and depart from those of the kangaroos. By being preceded by a bony platform, the *Nototherium* turbinals manifest characters of their own, although such states are dimly suggested in the skulls of native bears. The authors conclude that there was a similarity in the lip muscles of *Nototherium* to those of *Rhinoceros*.

**FLAGELLATES.**—Mr. E. Penard gives (*Proc. Acad. Nat. Sci. Philad.*, 1921) the results of studies on several flagellates. He describes in *Pteridomonas* the "flagellopodia," which may at one moment be flagella and at another form pseudopodia used in the capture of food—a rare condition in flagellates. *Dimorpha tetramastix* is, in the resting condition, a Heliozoan with fine radiate pseudopodia supported by axial filaments, and feeds on a minute ciliate which it captures with its pseudopodia. Arising from an anterior median depressed area are four very fine flagella, and by sudden retraction of the pseudopodia *Dimorpha* becomes a flagellate within the body of which traces of the axial threads of the former pseudopodia are visible. The organism swims by means of the flagella, but only for a short time, and on coming to rest reverts to the heliozoan form. Another new species of *Dimorpha* with only one flagellum is described, and this may also assume either the heliozoan or the flagellate form. The author has observed a flagellate stage of *Chrysamœba* and of *Chrysopyxis*; in each case the pseudopodia are retracted and a single flagellum is formed.

**BIRDS AND SOME INVERTEBRATES OF CEYLON.**—The outstanding contribution to the latest part of *Spolia Zeylanica* (vol. 12, part 45) is Mr. W. E. Wait's account of the passerine birds of Ceylon—a preliminary draft of a section for a proposed handbook on the birds of the island. In Ceylon the proportion of passerines in the avifauna is unusually small, for only about 120 species, about one-third of the total bird population, belong to this section, whereas in India fully half the species are passerines. The species are characterised in concise descriptions, followed by short accounts of distribution and habits, and keys are given to the distinctive characters of families and species. Two papers included in the part describe Ceylon Coleoptera—a new species of *Luciola*, and a collection of *Lamellicornia*; another continues a description of new species of Ceylon Diptera. Dr. Annandale has contributed a short



account of a polyzoon, *Plumatella longigemmis*, which occurred in the artificial lake whence Colombo obtains its water, and formed a continuous coating on the walls of the wash-water tank at the filtration works. Shorter notes deal with a new species of Lycanid butterfly (*Arhopala ornistoni*), with Lepidoptera of economic interest in Ceylon, and with the stridulation of a leaf-insect.

**SURFACE TEMPERATURES IN THE NORTH SEA AND IN GERMAN LAKES.**—The International Council for Marine Investigations has just issued a Bulletin Hydrographique (June 1922) containing a summary of all the observations of surface temperature in the North Sea during the years 1905–1914. There are more than 200,000 measurements made from commercial vessels and they are tabulated as means during each ten-day period for the mean year, and for areas of one degree of latitude and longitude, or for one-half degree, in each case. The results are represented graphically by a series of charts, one for each ten-day period. These show in a striking manner the "flow" of the isothermal boundaries throughout the year. A very interesting study of the temperature of the water at the surface of various lakes in Germany has been made by A. Merz (*Veröffentlich. Institut für Meereskunde, Berlin, N.F. A., Heft 5, 1920*). A specially constructed thermometer was used. The bulb was a vessel of 1 sq. mm. cross-section and 12 cms. long; the capillary stem was 15 cms. in length and was bent at right angles to the elongated bulb. Thus it was possible to explore the water at depths varying by 1 mm. down to about 110 mm. The results are quite remarkable: on very calm days, when there is no vertical disturbance of the water, the temperature may vary from about 21° C. at the surface, to about 8° C. at a depth of about 100 mm. Probably these results will have much significance.

**METEOROLOGY AT HONG-KONG.**—The report for the year 1921 of the Director, Mr. T. F. Claxton, of the Royal Observatory, Hong-Kong, has just been issued. A heavy rainfall occurred from April 27 to July 6, a period of 71 days, rain falling on 59 days and yielding 59 inches, or 61 per cent. of the total fall for the year. From September 9 to the end of the year, a period of 113 days, the rainfall amounted only to one inch. The total rainfall for the year was 97.34 in. and the average for the past 38 years is 84.62 in. The greatest rainfall in a day was 6.06 in. and the greatest in one hour was 3.25 in. The highest shade temperature was 92° on August 22; the highest in the past 38 years is 97°. The lowest temperature was 44° on February 4, and the lowest for the 38 years is 32°. The maximum wind velocity for one hour was 51 miles; the maximum for one hour in the past 38 years is 108 miles. The maximum squall velocity in 1921 was at the rate of 69 miles an hour. There were 21 typhoons during the year and the tracks of these are given in the Monthly Meteorological Bulletin for December 1921. In addition to meteorological observations kept at about 40 stations in China, meteorological logs were received from 168 ships operating in the Far East, the latter being used for verifying typhoon tracks.

**INTERFEROMETERS.**—Because of the high degree of accuracy obtainable, interferometric methods of measurement are of extreme value in physical research. The application of such methods has been rendered easily practicable by the various Hilger interferometers, which are specialised developments of the Michelson interferometer. The manufacturers,

Messrs. Adam Hilger, Ltd., 75a Camden Road, N.W. 1, now include a list of these instruments in their catalogue and have issued separate booklets describing them. The prism interferometer, the lens interferometer No. 1, and the camera lens interferometer (described in NATURE, July 14, 1921) are fairly well known and are used in connexion with various physical problems. A simple and compact form of instrument known as the "interferoscope" is now also available, by means of which the degree of parallelism of surfaces of transparent plates can be determined with more ease and rapidly and with greater accuracy than by micrometer measurement. Minute differences in the thicknesses of opaque parts, e.g. steel thickness gauges, plug gauges, balls for bearings, etc., can also be conveniently measured by placing three of the parts between two glass surface plates and measuring the lack of parallelism in the separation of the plates. As the accuracy obtainable with this instrument is about one-millionth of an inch it should form a valuable test-room tool as well as a physical laboratory instrument.

**CHEMICAL COMPOSITION OF THE EARTH'S CRUST.**—Prof. W. Vernadsky of the Radium Institute, Petrograd, writing from the Paris Muséum d'histoire naturelle, says it has been shown by Oddo and Harkins that the outer shell of the earth's crust, down to a depth of about 10 miles, consists predominantly of elements with even atomic numbers, but he believes that it is now possible to go further than this, and that it can be shown that the elements of different atomic numbers can be grouped according to the part they play in the economy of the earth's crust as follows: 1. *Cyclic (biogenic) elements.*—These constitute 99.6 per cent. of the mass of the earth's crust, and 86.4 per cent. of them are elements with even atomic numbers. These elements enter into the composition of organisms, and the chemical changes they undergo are cyclic. They include the following 28 elements: Ag, Al, As, B, Ba, C, Ca, Cl, Cu, Fe, F, H, K, Mg, Mn, N, Na, Ni, O, P, Pb, S, Si, Sn, Sr, Ti, V, and Zn; and probably also the following 10 elements: Bi, Cd, Co, Cr, Hg, Mo, Sb, Se, Te, and W. 2. *Inert gases.*—These have all even atomic numbers. They are chemically inert. They include A, He, Ne, Kr, and Xe. 3. *Elements of the rare earths.*—These include Ce, Dy, Er, Eu, Gd, La, Lu, Nd, Pr, Sa, Tb, Tm, Yb. It is characteristic of these elements that they take no part in the formation of vadose minerals. 4. *Radioactive elements.*—These include Ac, Nt, Po, Ra, Th, and U. They are genetically related to uranium and thorium and are subject to disintegration. 5. *Inert metals.*—These include Au, Ir, Os, Pd, Pt, Rh, and Ru. They do not give vadose minerals. 6. *Diffused elements.*—These include Br, Cs, Ga, In, I, Li, Rb, Sc, and Tl. It is a marked characteristic of these elements that they show very little tendency to form minerals, although their atoms are widely diffused through the rocks of the earth's crust. All the elements of this group have odd atomic numbers. Prof. Vernadsky points out that the chemical processes going on in the earth's crust are closely dependent upon the atomic constitution of the matter of the crust. A portion of this is always in an active state, and is, under present conditions, to be regarded as a store of free energy; e.g. those cyclic elements that undergo changes through the influence of radiant solar energy, and those radioactive elements which give a continual display of atomic energy. So long as these sources of energy are maintained, chemical changes will proceed in the earth's crust as at present; but the equilibrium is slowly changing, partly through dissipation and partly through the disintegration of the radioactive elements.

### The "Immured Standards" in the House of Commons.

AN interesting ceremony recently took place in the House of Commons, when the copies of the Imperial Yard and Pound which normally rest within the wall of the staircase leading up to the committee rooms, were replaced in their recess, and re-immured by cementing in place the stone slab covering the opening. These "immured standards," officially described as "Parliamentary Copies No. 4," constitute one of the four original sets of copies of the present primary standards of the yard and pound, and were constructed simultaneously with them in 1844-45, with the view of providing a ready means of replacement, should the originals at any time be lost or destroyed. Such a catastrophe occurred in 1834, when the Houses of Parliament were burnt down, the then existing standards being destroyed in the fire. The other sets of Parliamentary Copies were placed, and still remain, in the custody of the Royal Mint, the Royal Society, and the Royal Observatory, Greenwich. At a later date, a fifth set was provided for the Board of Trade, to obviate the necessity for using the primaries in important comparisons, as had been the practice hitherto.

Under statute, these copies must be compared with each other every ten years, and with the primary standards every twenty years, but the immured copies are expressly exempted from this requirement. Hence they have seldom been examined, and were only cursorily re-verified for the first time in 1892, when Mr. H. J. Chaney, the then Superintendent of the Standards, compared them with the Board of Trade copies, by means of apparatus which was taken to the House for the purpose. Since then they have not been disturbed until this year. Upon the present occasion, since this year marks the end of the twenty-year period, it was thought desirable to include the immured copies also in a complete set of inter-comparisons with the other copies and with the Imperial Standards themselves. With the kind consent of the Speaker, and in his presence, the recess was opened, and the standards taken out and inspected, before being removed to the Standards Department for verification. Upon the box there was found the certificate, in original, of their deposit in the present position, after the original site had been demolished during structural alterations. This certificate was dated March 7, 1872, and bore, among others, the signatures of Sir George B. Airy, Astronomer Royal, and Prof. W. H. Miller, both of whom had been closely concerned in the original construction of these standards.

All the comparisons in which the immured copies

were involved having been completed, they were returned upon August 3. Mr. J. E. Sears, Deputy-Warden of the Standards, produced them for identification by means of their inscriptions, and after Mr. Percy Ashley, Assistant Secretary to the Board of Trade, had explained the general purpose of the ceremony, the Deputy-Warden announced the result obtained by comparing them against the Imperial Standards. They were then formally replaced in their boxes, which were then hermetically sealed up within a lead sheathing, within an outer oak box, and replaced in the recess, in which they were again immured by cementing the front stone in place. Upon the box there had been placed a record of the proceedings, signed by the principal witnesses, together with the original certificate above referred to, which had been found when the recess was opened.

The results of the comparison of the immured standards with the primaries were given by Mr. Sears as follows:

Yard P.C. No. 4 = Imperial Standard Yard + 0.00010 inch.

Pound P.C. No. 4 = Imperial Standard Pound + 0.00286 grain.

These figures are, however, provisional, since due weight will ultimately have to be given to the results of the other comparisons which are not yet completed, and some adjustment will therefore be necessary. It is interesting to compare these figures with those arrived at in 1844-45, when the standards were first constructed, namely:

Yard P.C. No. 4 = Imperial Standard Yard + 0.000007 inch.

Pound P.C. No. 4 = Imperial Standard Pound - 0.00314 grain.

The apparent variation in the yard is of the order of the differences which have been observed from time to time in the past among the other standard bars, but the apparent change in the pound is more considerable. It may perhaps be explained by the fact that the weight is by no means a good piece of metal, and of all the copies, it constitutes probably the one least fitted to form a trustworthy standard. Some evidence is, however, available, though it cannot be regarded as conclusive, that prior to 1878 the primary standard was rendered a little lighter by wear, arising from its relatively frequent use for important comparisons. The present series of comparisons may render it possible to form some conclusion as to whether this is the case.

### The International Research Council.

A MEETING of the International Research Council was held at Brussels on July 25 and the four succeeding days, under the presidency of M. E. Picard, secretary of the Académie des Sciences, Paris; simultaneously the recently formed Union of Scientific Radio-Telegraphy held its first general assembly.

Twenty countries have now joined the International Research Council, the following seventeen being represented at the meeting: Belgium, Canada, Denmark, France, Great Britain, Greece, Holland, Italy, Japan, Norway, Poland, Portugal, Spain, Sweden, Switzerland, United States of America, and Czechoslovakia. The representatives of Great Britain for the general proceedings of the Council were Prof.

J. R. Ashworth, Sir William Bragg, Sir Charles Close, Sir Richard Glazebrook; Mr. A. R. Hinks, Col. H. G. Lyons, Sir Arthur Schuster, and Dr. E. H. Starling; while in addition Admiral Sir Henry Jackson, Dr. Erskine Murray, and Mr. Shaughnessy represented, together with Sir Richard Glazebrook, the National Council for Radio-Telegraphy.

The greater part of the business of the meeting was concerned with the organisation of international scientific unions additional to the five for Astronomy, Geodesy and Geophysics, Chemistry, Mathematics, and Scientific Radio-Telegraphy, which are already in activity. As a result of the meeting the formation of Unions for Pure and Applied Physics and for Geography seems assured. The proposed Union in

Geology awaits the consideration of the Geological Congress which meets this week at Brussels, and some advance has been made in connexion with the biological sciences.

At a previous meeting of the International Research Council it had been provisionally agreed to unite medical and biological sciences; this decision did not find favour, and the intention now is to separate medicine from Physiology, Zoology, and Botany. Proposals will be submitted to the countries belonging to the Research Council, and the ultimate formation of this Union will depend on the number of countries willing to join.

Among other matters dealt with, a proposal submitted by the National Research Council of the United States of America and accepted by the meeting may prove to be an important addition to the responsibilities of the Research Council, which hitherto contented itself with the formation of Unions which became practically autonomous as soon as their statutes were approved. As problems in which several Unions were concerned ran a danger of being neglected, the proposal was now made by the United States that the Research Council itself should take such

problems under its own special protection. Three inquiries were mentioned as likely to fall within this category. One of them had already been considered by the International Astronomical Union, which requested the Research Council to make arrangements for a collaboration of several of the Unions in the study of the correlations between solar and terrestrial phenomena. The second referred to the energy supply of the world (fuel, solar energy, etc.), while a third suggestion dealt with the difficult and complicated question of international patents. The risk of overlapping efforts and the possible fear of interference with the special work of the Unions is avoided by the provision—now coming into force—that the Executive Committee of the Research Council, which hitherto consisted of five members, should be enlarged, each Union nominating an additional member.

At the concluding meeting the five members of the Executive Committee appointed by the general assembly were elected as follows: M. E. Picard (President), Mr. G. Lecomte and Prof. Vito Volterra (Vice-Presidents), Dr. G. E. Hale, and Sir Arthur Schuster (General Secretary).

### The Philosophical Congress at Manchester.

THE special subjects of discussion at the Philosophical Congress recently held at Manchester were (1) the nature of history and its differentiation from science, (2) the concept of unconscious mental process and the justification of the term unconscious in psychology, and (3) the philosophical aspects of the principle of relativity, particularly in regard to the problem of sense perception.

The vice-chancellor of the University of Manchester, Sir Henry Miers, presided at the opening meeting, when the Bishop of Manchester, Dr. William Temple, gave an inaugural address on "Symbolism as a Basis for Metaphysics." The particular function of philosophy is the interpretation of value. Reality presents itself in grades which rise in a hierarchical order from simple matter to life and mind and spirit. Each higher order is the imposition of a value on the lower on which it is dependent and which then becomes for it a symbol. Thus a flag as a particular strip of calico is mere matter and yet apart from the value which this matter symbolises it has not even the existence which supports the value. That is to say, though existence is prior to value, in the higher grade the distinction between existence and value disappears. This led to the further position that the universe can only be explained in terms of will. The intellect may be satisfied by a concept of the universe in terms of physical causation, but religious, aesthetic and ethical, and also scientific experience can only be satisfied by proof that it is purposively reasonable and not merely causally intelligible.

(1) "Are History and Science different kinds of Knowledge?" was discussed in a symposium by Mr. R. G. Collingwood, Prof. A. E. Taylor, and Dr. F. C. S. Schiller. The problem is an old one but has acquired new significance in modern thought. History is particular and individual, its events are unique, it is impossible to classify them and induce general laws. Is it then more than a simple chronicle? On the other hand, science deals with repetitions, its method is experimental, it formulates general laws which enable us to predict and so to control the future.

(2) The subject of the unconscious aroused the liveliest interest on account of its practical importance

and the question of the methods of psycho-therapy which it involved. Prof. T. H. Pear presided over the discussion and referred to the great loss which psychology had sustained in the death of Dr. W. H. R. Rivers, who had taken part in arranging the programme and had expected to participate in the Congress. The meeting rose in silent tribute. The first symposium, "Is the Unconscious a Conception of Value in Psychology?" was by Mr. G. C. Field, Dr. F. Aveling, and Prof. J. Laird. In the discussion the medical point of view was represented by Dr. Mitchell and Dr. William Brown. The latter gave detailed instances of assumed mental processes which, judged by analogy, are indistinguishable from those of conscious life, the only difference being that the subjects in whom they occur are completely unaware of them. Mr. Leonard Russell on the philosophic side defended the use of the apparently self-contradictory term "unconscious consciousness" in a subtle argument directed to show that the paradox is not confined to a particular class of mental phenomena but extends to all, for even in what we call conscious process we are never conscious of the consciousness.

A second symposium on the terms used in the new psychology, "The Relations between Sentiments and Complexes," had six contributors. The first paper was by the late Dr. Rivers, the others were by Dr. Bernard Hart, Mr. A. G. Tansley, Prof. T. H. Pear, Mr. A. F. Shand and Dr. C. S. Myers. The practical issue in this discussion was as to a possible danger in psycho-analysis. Complexes were acknowledged to be harmful and psycho-analysis was directed towards dissolving them, but in doing so might there not be risk of dissolving sentiments which were wholly healthy?

(3) A discussion between Prof. G. F. Stout and Prof. Alexander on the nature of sense perception was preliminary to a more general discussion on a paper by Prof. A. N. Whitehead, "The Philosophical Aspects of the Principle of Relativity." The tendency of the new concept was, Dr. Whitehead said, distinctly to support the line of argument of those who followed Berkeley, and yet it was wrong to suppose that Einstein's principle implied or was even ultimately consistent with the full idealist

doctrine. The new law of gravitation quite as fully as Newton's law referred to a nature common to and independent of all individual minds. This was a necessity if there was to be physical science at all in any intelligible meaning of the term. The chairman, Prof. Willdon Carr, said that the idealistic interpretation of Einstein's theory did not imply that Einstein was an idealist or that any philosophical purpose was involved in his principle. The value of the new principle in philosophy depended on the fact that it was purely scientific and brought forward in the interest of mathematical physics. What it had done for philosophy was to show conclusively that the realist assumption of independent objective existence was not only unnecessary as a condition of the possibility of science but was a positive methodological hindrance.

Concurrently with the philosophical discussions the psychologists held a meeting in the psychological laboratory for the reading of papers and demonstrations.

On Saturday the British Psychological Society held separate meetings in the Medical School of the University. In the morning, with Prof. T. H. Pear in the chair, Dr. C. S. Myers described a number of experiments upon the various factors involved in

the appreciation of music. He showed how closely the processes of listening to music may follow those involved in the response to pure tones, and considered especially the parts played in the aesthetic enjoyment of music by association, by a process of "distanting," and by "mystical feeling." Mr. F. C. Bartlett gave an account of some experiments leading up to a psychological study of the processes of conventionalisation; and Mr. R. H. Thouless discussed the phenomena of contrast in a smoothly graded disc. It was suggested that McDougall's drainage theory could scarcely be accepted as an adequate explanation of the contrast effects, a view that obtained support in the ensuing discussion. In the afternoon the Industrial Section of the Society held a meeting. Dr. Leslie Mackenzie presided. Mr. E. Farmer presented a new method of dealing with curves of output in factory work, and discussed the psychological significance of certain curves representing work in chocolate-packing and glass-blowing. Prof. A. V. Hill demonstrated his ergometer, and spoke to a large audience on characteristics of muscular work in the intact organism. Mr. Jackson read a paper prepared by Mr. S. Wyatt and himself on the effect of rest pauses upon output curves.

### The Congress of the Royal Sanitary Institute.

THE thirty-third Annual Congress of the Royal Sanitary Institute at Bournemouth, which was held during the last week in July, displayed the multifarious character of the work embraced in sanitary science or public health. Special sections were devoted to sanitary science and preventive medicine, to engineering and architecture, to maternity and child welfare including school hygiene, to personal and domestic hygiene; and there were conferences of veterinary inspectors, health visitors, sanitary inspectors, representatives of sanitary authorities, and medical officers of health.

Major-General J. E. B. Seely's presidential address was an able summary of urgent public needs, an appeal for clean milk and for judicious expenditure on public health needs including housing, and a reiteration of the fundamental importance of education in advancing public health progress.

Sir Arthur Newsholme's presidential address to section I dealt with the relative rôles of compulsion and education in public health work. He laid down the following general principles as justifying compulsion in public health or social work: (1) that the end aimed at by compulsion must be very important for the public welfare; (2) that it cannot be achieved to an equal extent or within a reasonable time by educational measures, not including the education provided by education; (3) that the compulsion can be enforced; and (4) that it is continuously endorsed by a majority of the community. He gave examples of the fact that the social history of the 19th century consists largely in a steady extension of the enforcement of compulsory duties and restrictions in various aspects of communal life, each of which had been introduced to secure the larger liberty of the oppressed and handicapped members of the community; and then proceeded to apply these general principles to the case of two chronic communicable diseases like tuberculosis and syphilis, and to alcoholic indulgence. His general conclusion was that compulsion in these directions would be effective inversely to the extent to which it was needed; and that in the ultimate issue the two ideals of compulsion and of education of character are not irreconcilable in public health work.

In his address in the maternity and child welfare section, Sir George Newman stressed the continuing but avoidable loss of maternal and infant life, occurring through ignorance and still more through lack of care, and the still larger suffering and disablement of mothers and infants which might have been avoided. The fact that 35 per cent. of the children first admitted to the elementary day schools in England are so physically impaired as to need medical treatment, emphasises the importance of hygienic and medical care of the mother and of the infant before school age is reached. At the present time about 8d. per head is being spent on official services of maternity and child welfare, while the financial value of the lives saved by these services exceeds this sum many times over.

There was a useful discussion on "Fuel in relation to health" introduced by Prof. J. W. Cobb of Leeds University. In his paper Prof. Cobb traced the history of the stages through which the manufacture of gas for domestic purposes had passed. The New Gas Regulation Act had accepted the fact that the test of intrinsic luminosity was absolute, had permitted the distribution of gas of a lower calorific value than formerly, and had not laid down any limitation of the amount of carbon monoxide in gas. Evidently Prof. Cobb did not regard increase of carbon monoxide as necessarily increasing danger to the consumer, and he pointed out that although recently more cases of poisoning by this gas had been recorded, they could not be due to increase of its proportion, inasmuch as action in this direction so far had not been great.

In a paper on smokeless methods in Glasgow housing schemes Councillor W. B. Smith emphasised the too little recognised fact that soot from domestic fires is worse than that from boilers of manufacturing plants, on account of the excess of tar products, and advocated central provision of hot-water supplies in towns.

Lieut.-Colonel Clemesha described methods of collection and disposal of excreta suitable for small tropical villages, where, as a rule, there is a total absence of all sanitary arrangements. This leads not only to excessive cholera and enteric fever, but to the widespread dissemination of anchylostomiasis,

a parasitic disease, perhaps more destructive of health and efficiency than either cholera or malaria. It was necessary that the provision made for such villages should be primitive in character, and the "pit latrine" was the most satisfactory in most circumstances. Such latrines obviate the need for any conservancy staff and they greatly diminish surface contamination of the ground, and thereby reduce the possibility of spreading hookworm disease. Many of these simple arrangements have been in existence for hundreds of years in countries like Persia, Arabia, and Mesopotamia, and have given rise to no nuisance, but are in all respects satisfactory.

A few only of the subjects discussed at this Congress have been mentioned. The educational value of such meetings stands high. The Congresses of the Royal Sanitary Institute are unique in that they focus the views and wisdom of every profession and calling bearing on public health whether legal or medical, engineering or architectural, women workers voluntary or officials, medical officers of health or sanitary inspectors, veterinary and medical inspectors, representatives of sanitary authorities, and the workers in voluntary organisations. Out of exchange of outlooks from these various angles public health progress is secured.

### Pharmaceutical Education and Research.

AT the British Pharmaceutical Conference, held at Nottingham on July 24-27, the President, Prof. H. G. Greenish, delivered an address on "Pharmacognosy and the Pharmaceutical Curriculum." Pharmacognosy, he said, was a field of knowledge that the pharmacist was peculiarly fitted to cultivate, but he would not be able to do so satisfactorily unless he had received a sound preliminary education and had been subsequently trained in chemistry, botany, physics, and elementary zoology. The entrance examination to pharmacy should, he thought, be raised to the level of matriculation, and the training in the sciences upon which pharmacognosy is based should follow and not precede the practical training in the pharmacy which is necessary before the student can present himself for the Qualifying Examination. Dealing with the course of instruction in botany, this, he thought, should be adapted to the object the student had in view, special attention being paid to anatomy, morphology, physiology, and systematic botany.

The training in pharmacognosy should be of a more general and more practical nature than was at present often the case, and should include the determination of diagnostic characters by means of the lens or the microscope or by qualitative chemical tests as might be requisite. In this respect a detailed syllabus was a disadvantage, as it restricted the freedom of thought and the development of a spirit of inquiry which was essential to true progress. In the advanced course of instruction and in the major examination more stress should be laid upon the identification of powdered drugs, the analysis of mixed powders, and the assay of drugs by chemical methods. Opportunity for post-graduate work was very necessary and every possible inducement should be offered to the student to undertake it. The Universities of Manchester and Glasgow had made arrangements for pharmaceutical subjects to form part of the examination for the degree of Bachelor of Science, and if the University of London could be induced to make a similar arrangement a considerable step forward would be made.

The student who had attended advanced courses of instruction in the selected subjects would then be

in a position to take the degree of B.Sc. From this he could proceed without difficulty to the degree of doctor of philosophy, the requirement of the University of London being broadly two further academic years of study, including the presentation of a thesis on an approved subject. The work for the thesis could be carried out in an institution such as the research laboratories of the Pharmaceutical Society under teachers recognised by the University. The field of pharmacognosy is so wide, and the problems that await solution are so diversified in their nature, that no difficulty would be encountered in selecting subjects suited to the varied abilities of the students. Great assistance would be rendered in this work by the establishment of an experimental station similar to the Pharmaceutical Experimental Station of the University of Wisconsin at which the material necessary for investigation could be grown and experiments carried out. Possibly such a station could be established in connexion with one of the agricultural colleges.

The determination of the Pharmaceutical Society to foster its scientific work more in the future than it has done in the immediate past was one of the most hopeful signs for the future of pharmacy, and the society, by developing the work which pharmacists were specially trained to do, would go far to establishing its position as a learned society. The president concluded by saying that there might be obstacles to be surmounted, misunderstandings to dispel, and prejudices to be overcome, but the spirit of the pioneers of scientific pharmacy existed to-day and, though latent, was strong. The society should set its educational policy in the direction indicated by the wisdom of its founders and foster the love of the calling which distinguished its early years. So alone would pharmacy ensure for itself the appreciation of a nation.

### University and Educational Intelligence.

LONDON.—Dr. George Senter, principal and head of the department of chemistry, Birkbeck College, has been selected by the University of London Graduates' Association as candidate for the vacancy in the representation of science graduates on the Senate of the University, caused by the election of Dr. Walmsley to the chairmanship of convocation. Dr. Senter was formerly a member of the Senate, and has for many years taken an active part in University affairs.

DR. WALTER RITCHIE, assistant lecturer in biology in the University College, Aberystwyth, has been appointed assistant lecturer in biology at the Technical College, Bradford, in succession to Mr. L. P. W. Renouf, who resigned his appointment on his election to the professorship of zoology in the University of Cork.

IN accordance with the terms of the will of the late Sir Archibald Dawnay, the Royal Institute of British Architects has awarded, for the first time, two scholarships, each of 50*l.* per annum for two years, to Mr. E. U. Channon, Architectural Association, and Mr. D. J. A. Ross, Robert Gordon's Technical College, Aberdeen; and one scholarship of 25*l.* per annum, for two years, to Mr. C. S. White, Architectural Association. The scholarships are intended to foster the advanced study of construction and the improvement generally of constructional methods and materials and their influence on design.

THE British Research Association for the Woollen and Worsted Industries announce the following awards of research fellowships and advanced scholarships for the year 1922-23: Mr. G. W. Chester, Liverpool, 200*l.* to conduct research on wool fats at the University of Manchester; Mr. John L. Raynes, Nottingham, 100*l.* to conduct research on the bleaching of wool at the University College of Nottingham; Mr. George Barker, Baildon, 100*l.* to conduct research on the action of water on wool as regards strength, elasticity, lustre, dyeing properties, etc., at the University of Leeds. Scholarships have been granted to Mr. Arthur Banks, Sutton Mill, Keighley, tenable at Bradford Technical College; and Mr. William B. Elliot, Wellington Road, Hawick, tenable at the South of Scotland Central Technical College, Gala-shiels.

THE Ministry of Agriculture and Fisheries announces that scholarships in higher agricultural education are offered to the sons and daughters of small-holders and agricultural and other rural workers. The scholarships are of three types: Class I, enabling the holder to attend the degree courses in agriculture at certain University departments (including the School of Rural Economy, Oxford, and the School of Agriculture, Cambridge); Class II, tenable for two years at certain University departments of agriculture and agricultural colleges; and Class III, tenable for one year or less, at a farm institute or similar institution. Candidates for Class I, and Class II, scholarships must be at least 17 years of age, and must show that they have sufficient ability to pass the entrance examination of the Institution at which the scholarship will be tenable; for Class III, awards, candidates must be more than 16 years of age and have spent at least a year on a farm or in a horticultural establishment. Applications should reach the Secretary, Ministry of Agriculture and Fisheries, 10 Whitehall Place, London, S.W.1, not later than August 31.

THE United States National Research Council has made an attempt to ascertain by statistics the relative support given to the arts and the sciences through fellowships and scholarships in the graduate schools of American universities. The result (Reprint and Circular series No. 29, 1922) points to the conclusion that the arts are in this respect more favoured than the sciences. Of 3377 fellowships and scholarships awarded during five years in the graduate schools of arts and sciences of twelve leading universities, 1892 were in arts subjects, 1289 in pure science, and 196 in applied science. The arts subjects were chiefly: English and modern languages (615), history (328), ancient languages (250), philosophy (108), economics (171), political science (153); the pure sciences—biology (400), chemistry (365), physics (152), mathematics (145), geology (104); applied sciences—engineering (105), agriculture (58). The figures do not, however, in any way indicate the extent to which applied sciences are encouraged in the universities, because they do not include the fellowships awarded in the professional schools. A comparison of the number of fellowships awarded with the number of doctorates conferred year by year in the natural sciences discloses in some cases a close parallelism between the two sets of figures; thus in California the numbers of fellowships and doctorates respectively in the five years 1916-17 to 1920-21 were: 23, 23; 16, 16; 15, 16; 21, 14; 25, 22; and in Stanford in 1918-19 to 1920-21: 2, 2; 4, 4; 5, 5. The total number of such fellowships in the natural sciences in the twelve universities during five years was 290, and the number of doctorates 248.

### Calendar of Industrial Pioneers.

**August 13, 1867.** James Shanks died.—Trained at Glasgow University, Shanks abandoned medicine for practical chemistry and in 1836 was employed by Gossage in the erection of his condensing towers. He then became connected with the firm of Joseph Crosfield and Sons, Ltd., at St. Helens; among the notable improvements he made being the introduction of the "Shanks' Vats" used for the lixiviation of black-ash in the production of alkali.

**August 14, 1909.** William Ford Stanley died.—A native of Buntingford, Hertfordshire, where he was born in 1829, Stanley was trained in mechanics by his father, and in 1854 founded the well-known firm of scientific instrument makers. Besides effecting improvements in the design and manufacture of drawing and surveying instruments, he published standard works on their use and was a versatile writer on various scientific subjects. He was also an enthusiastic promoter of trade schools.

**August 15, 1913.** James Robson died.—Known for his pioneering work on the gas engine, Robson, who was born in South Shields in 1833, began life as an ironmonger and plumber. Turning his attention in 1855 to the internal combustion engine he built several successful gas engines, and in 1877 took out a patent for a two-stroke engine in which all the pumping and motor actions are performed by one piston in a single cylinder. Robson's first engine on the two-cycle plan was built at North Shields in 1879, and shortly afterwards their manufacture was taken up by Tangye's of Birmingham.

**August 16, 1818.** Jacques Constantin Périer died.—An able mechanic, Périer founded an engineering works, introduced steam-pumps and hydraulic presses into France, and became a builder of steam-engines. He also invented a centrifugal pump, and drew up a plan for the distribution of the water of the Seine throughout Paris. He published various scientific memoirs, and from 1784 was a member of the Paris Academy of Sciences.

**August 17, 1809.** Matthew Boulton died.—The founder in 1762 of the Soho Manufactory at Birmingham, Boulton was a successful toy and trinket maker. His friendship with Watt led in 1775 to the famous partnership which made the Soho works known throughout the industrial world. It was there that the modern steam-engine may be said to have had its birth, and much of the success achieved was due to Boulton's energy and business acumen. Boulton himself made many improvements in the art of coining.

**August 18, 1874.** Sir William Fairbairn died.—A great mechanical engineer, Fairbairn as a journeyman-mechanic gained experience in various parts of the country, and in 1817 set up in business in Manchester. He introduced many improvements in millwork, was a pioneer in iron shipbuilding, with Robert Stephenson built the Britannia Bridge over the Menai Straits, and made original investigations into the strength of materials, the properties of steam, and other subjects.

**August 19, 1808.** Frederic Henry Chapman died.—Recognised as the foremost naval constructor of his day, Chapman was born at Göteburg in 1721. As a young man he worked in London, and after visiting France became a constructor in the Swedish Service, and towards the end of his career invented the parabolic system of construction. His principal writings were his "Architectura Navalis Mercatoria" published in 1768 and a work on Ships of War published in 1775. E. C. S.

## Societies and Academies.

## EDINBURGH.

**Royal Meteorological Society, July 24.**—Dr. C. Chree, president, in the chair.—C. K. M. Douglas: Observations of upper cloud drift as an aid to research and to weather forecasting. The condition of the wind near the top of the troposphere in different stages of a cyclone is discussed. The pressure distributions aloft, disclosed by the upper winds, are considered in relation to temperature, as the pressure at considerable heights is largely determined by the temperature of the column of air underneath. There is complete lack of symmetry in the temperature distribution over a cyclone in its earlier stage, with a great contrast in the temperature of the whole troposphere between the "polar" and "equatorial" currents. When the cyclone becomes stationary and fills up, the distribution of temperature and wind in the upper air approaches to symmetry round the centre, and the easterly current on the north side often extends throughout the troposphere. No simple rules for weather forecasting can be drawn up, as the changes in the wind at considerable heights follow rather than precede those near the surface, but observations of high cloud motion are valuable, for they indicate the temperature distribution in the troposphere.—J. S. Dines: Note on the effect of a coast line on precipitation. A convergence effect occurs over a coast line when the wind blows along the coast, the low pressure being over the sea and the high pressure over the land; this may cause precipitation. Under favourable conditions an upward current of 15 feet per minute may be produced over a strip of the earth's surface extending 5 miles on each side of the coast line. A similar effect occurs wherever the pressure gradient varies along a line perpendicular to the isobars, and the following rule is deduced: "In any area, where the pressure gradient increases towards the 'High' there will be rising air."—A. E. M. Geddes and C. A. Clarke: Note on turbulence, as exhibited by anemometer records, smoke and cloud formation. The effect of eddy motion is shown near the surface by the records from a pressure tube anemometer. The turbulence and consequent eddy motion depend largely on the nature of the surface over which the air current is travelling. Eddies higher up are shown by smoke from tall chimneys. Higher up, cloud of the stratus order is formed. Smoke eddies and clouds occur when there is little or no convection due to heated air, and therefore their appearance and formation is evidently in accordance with Taylor's theory of eddy motion. Eddies occur at the junction of two currents of different temperature, and fragments of cloud form below the base of the line squall or similar cloud. Cloud intermediate between the normal cirrus and cirro-cumulus types undergoes changes which are at present unexplained. The change of the cirro-cumulus type, regarded as a water-droplet cloud, into the ice-crystal structure of true cirrus is only to be expected at high altitudes and consequently generally very low temperatures, but the reverse process occurs frequently.

## PARIS.

**Academy of Sciences, July 10.**—M. Emile Bertin in the chair.—Paul Janet: The standard reproduction of the international ohm. An account of the preparation of eight standard mercury ohms by the late M.

René Benoit. The differences between the values measured by electrical methods and the values deduced from the geometrical dimensions did not amount to more than a few hundred-thousandths. The mean of the absolute values of the deviations was  $1.9 \times 10^{-5}$ .—E. Cartan: A fundamental theorem of H. Weyl in the theory of metric space.—A. Châtelet: Finite Abelian groups.—J. Guillaume: Observations of the sun made at the Observatory of Lyons during the first quarter of 1922. Observations were possible on 74 days during the quarter; the results are summarised in three tables showing number and area of spots, their distribution in latitude and the distribution of the facule in latitude.—G. Sagnac: The oscillations of the spectral lines of double stars explained by the new law of projection of energy of light.—E. M. Lémeray: General relativity and the Milky Way.—R. Jouast: Comparisons of the standard reproductions of the international ohms. The standards constructed by the late M. René Benoit were compared by Kelvin's double-bridge method. Of the ten originally constructed one was rejected owing to an accident in mounting, and another had also to be rejected on account of an apparent discontinuity in the tube. Details of the measurements are given. The values range between 0.99984 ohm and 1.00015 ohm.—Vasileco Karper: A particular class of batteries. A voltaic cell is formed by a mixture of amyl alcohol and water containing zinc sulphate in solution. This separates into two phases, the upper being amyl alcohol, the lower an aqueous solution of zinc sulphate. With zinc electrodes this cell gives an E.M.F. of 0.7 volt. The results obtained with this and similar cells are not in accord with Nernst's osmotic theory of cells, and appear to contradict the second law of thermo-dynamics.—P. Janet: Remarks on the preceding communication. It is necessary to prove rigorously that the cycle formed by the substances present constitutes a closed cycle.—Albert Granger: Observations on the baking of ceramic products in electrically heated furnaces. With platinum-wound furnaces the highest temperature attainable with safety is about 1300° C. For higher temperatures a granulated carbon resistance is necessary. A grey tint on the porcelain made in this furnace was proved to be due to the action of carbon monoxide passing through the wall of the tube (corundum mixed with a refractory clay).—R. Locquin and Sung Wouseng: Aldehydes obtained starting with tertiary alcohols.—F. Boiry: Vulcanising rubber in solution. A study of the interaction of indiarubber in colloidal solution and sulphur with different solvents at high temperatures (over 120° C.). With phenol as solvent the compound produced contained 31.5 per cent. of sulphur, approximately corresponding to  $C_{10}H_{16}S_2$  (32 per cent. sulphur), which may be considered as the ultimate product of vulcanisation.—Hervé de Pommereau: The reduction of ethyl  $\alpha$ -naphthylacetate and of the  $\alpha$ -naphthyl-ethanols by sodium and absolute alcohol.—Emile André: Contribution to the study of grape seed oil. Study of the solid fatty acids. Method of separating stearic and palmitic acids.—A. Duffour: A new example of hemihedral forms not conforming to the sign of optical activity.—Gabriel Bertrand and Mokrgnatz: The presence of cobalt and nickel in arable soil. The method of extracting these metals from the soil and identifying them is given in detail. A specimen of garden soil (Pasteur Institute) has given 0.0037 gm. cobalt and 0.0174 gm. nickel per kilogram of soil.—I. Athanasiu: Nervous motive energy. Electroneurograms.—A. Desgrez, H. Bierry, and F. Rathery: The state of acidosis. Method of proof and treatment.

## CAPE TOWN.

Royal Society of South Africa, June 21.—Dr. C. F. Juritz in the chair.—S. H. Haughton: On some upper Beaufort Therapsida. A new genus of Cynodont reptile, *Cynidiognathus*, for the species *C. longiceps* based on a skull from the Burgersdorp Beds is described. Its dental formula is  $14c1m1o$ . There are well-marked palatine processes of the premaxilla, no prevomers, and the epipterygoid is retracted from the quadrate. A skull thought to be *Cynognathus berryi* is assigned to the new genus under the name of *C. broomi*. The palate and basicranium of *Elurosuchus* is discussed; the genus belongs to the Bauriamorpha.—T. J. Mackie: Observations on the protective action of normal serum in experimental infection with *Bacillus diphtheriae*. In guinea-pigs experimentally infected with *B. diphtheriae*, normal serum from various animals, injected subcutaneously at the same time as the inoculation, exerts a definite protective action. No protection occurs if the serum injection is delayed for 2 hours after the inoculation—the effect is prophylactic, not curative. The activity of the serum persists at 57° C., but is lost at 70° C. and higher. Serum from one guinea-pig injected subcutaneously into another is fully protective or exerts a delaying effect; it is noteworthy that serum of an individual of species highly susceptible to experimental *B. diphtheriae* infection should be capable of affording some protection when injected parenterally into another animal of the same species infected with the particular organism. Normal horse serum is also protective in guinea-pigs injected with diphtheria toxin.—W. A. Jolly: Note on the electrogram of the frog's gastrocnemius reflexly excited. Records of the electrical change in the gastrocnemius when contraction is elicited reflexly by mechanical stimulation of the heteronymous foot, show that the response of the muscle is of the nature of a tetanus.—J. S. van der Lingen: Note on a cystoscopic irradiator and an ultra-violet light illuminator. The illuminator consists of a lens-system, of two quartz lenses and an iris diaphragm, whereby a field may be illuminated with any desired group of ultra-violet waves. One irradiator takes the form of a quartz-rod or tube shaped like a cystoscope, and the illuminator, by which rays are passed into the organs to be illuminated. The rays pass out only at the spherical tip. The other form consists of an exhausted tube bent into the form of a cystoscope, with a bulb at the external end containing a small quantity of mercury. Carbon-monoxide is introduced into the tube by heating, and this causes the mercury to radiate at a low temperature, when a high-frequency field oscillates in a helix placed over the external end of the tube.

## SYDNEY.

Linnean Society of New South Wales, May 31.—Mr. G. A. Waterhouse, president, in the chair.—G. D. Osborne: The geology and petrography of the Clarencetown-Paterson district. Pt. 1. The descriptions are based upon an exhaustive survey of about 200 sq. miles containing rocks of the Burindi Series, Kuttung Series and the Cainozoic System. It is suggested that the Kuttung Series be divided into a basal stage, a volcanic stage, and a glacial stage in consequence of modifications found in the general sequence, the most important of which is the discovery of glacially-produced rocks on a much lower stratigraphic level than hitherto recognised. Five detailed sections of the volcanic stage are described. The work confirms

the broad stratigraphical succession as given by C. A. Sussmilch.—G. F. Hill: Descriptions and biology of some North Australian termites. Four new species and two hitherto undescribed castes of the genera *Eutermes* and *Hamitermes* are described.—J. B. Cleland: A second bird census.—A census of the numbers of species and individuals observed on a series of journeys in various districts. The districts covered are southern coastal Queensland, Blue Mts., N.S.W., South Western Plains, N.S.W., Adelaide and Renmark Districts, S.A., and the Central Northern District, S.A.

Royal Society of New South Wales, June 7.—Mr. C. A. Sussmilch, president, in the chair.—A. R. Penfold: The isolation and identification of the acid bodies produced by the oxidation of piperitone by means of potassium permanganate. The ketone used was from *Eucalyptus dives*, and three acids were identified.—M. Henry: The incidence of anthrax in stock in Australia. Introduced originally about eighty years ago, anthrax attained serious proportions in certain districts, but during the last thirty years there has been a decline in the area infected. The disease has always been definitely localised. It was introduced near Sydney and carried inland and into Victoria but then disappeared from its original areas. At present most of the coastal districts, the tablelands and the Western Division of New South Wales are anthrax free. The real anthrax country consists of a belt in the western slopes; in Victoria there is a similar belt. Queensland is free, and possibly was never affected, and in the rest of Australia the disease is negligible. The season of greatest danger from anthrax is the summer and early autumn. The mortality from it is not heavy. There is an inhibitive factor which has prevented anthrax becoming more widespread. Among human agencies the controlling factors have been vaccination, quarantine, destruction of carcasses by fire, breaking up of large estates, and substitution of agricultural for pastoral activities. Contaminated soil is generally the source of infection; infected feeding-stuffs, the common source of infection in England, do not operate.—E. Cheel: (1) Notes on the species of *Darwinia Homoranthus*, and *Rylstonea* in the states of New South Wales, Victoria, South Australia and Queensland. The plants are known as "Fringe Myrtles" or "Scent Myrtles," and are said to be of importance on account of the essential oil contained in the leaves. The plants known as *Darwinia taxifolia* are very variable and great care is necessary in the selection of material if pure grades of oil are required. Plants originally collected at Rylstone and given the name *Rylstonea* are probably forms of *Verticordia darwinoides*. (2) Notes on *Melaleuca linarifolia* and *Melaleuca trichostachya*. These species are commonly known as "Tea Tree" and "Tee-doo" respectively, and are also said to be of importance on account of the essential oil contained in the leaves.

## Official Publications Received.

Imperial Department of Agriculture for the West Indies. Report on the Agricultural Department, St. Kitts-Nevis, 1920-1921. Pp. iv+33. (Barbados.) 6d.

Department of Agriculture, Trinidad and Tobago. Administration Report of the Director of Agriculture for the year 1921. Pp. 12. (Port-of-Spain, Trinidad.) 6d.

On the State of the Public Health: Annual Report of the Chief Medical Officer of the Ministry of Health for the year 1921. Pp. 115. (London: H.M. Stationery Office.) 1s. 6d. net.



# NATURE

A WEEKLY ILLUSTRATED JOURNAL OF SCIENCE.

*"To the solid ground  
Of Nature trusts the mind which builds for aye."*—WORDSWORTH.

No. 2755, Vol. 110]

SATURDAY, AUGUST 19, 1922

[PRICE ONE SHILLING

Registered as a Newspaper at the General Post Office.]

[All Rights Reserved.]

## BALANCES & WEIGHTS



## REYNOLDS & BRANSON, LTD.

LABORATORY FURNISHERS AND MANUFACTURING CHEMISTS.



**Balance, Analytical, Rystos**  
New Model. Improved vertical movement of rider hook, rider scale running from end to end of beam and plumb line. The bearings are agate throughout; the beam of hard mahogany. Case of black crystal. Hinged side doors and sliding back and brass levelling screws. To carry 200 grammes, sensitive to 1th milligramme, or  $\frac{1}{10}$ th milligramme with a less load . . . . £14 14 0

*Balances renovated and repaired in our own Workshops.*

For Analytical and other Balances and Weights, see special Catalogue Post Free on request.

14 Commercial Street, Leeds.

## SPECTROMETERS

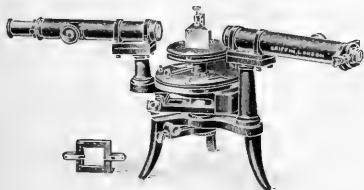

*Particulars and Prices on application to—*

**JOHN J. GRIFFIN & SONS, LTD.**

Kemble Street, Kingsway,  
London, W.C.2.

## BAROGRAPHS

Four rubber feet to the base—  
—a self-adjusting pen arm—  
—a supporting rod to the cover—  
—these are some of the refinements  
on our Recording Barometers.  
Write for price list "B.3."

**NEGRETTI & ZAMBRA**  
38, HOLBORN VIADUCT, E.C.1.  
LONDON.

FACTORY : HALF-MOON  
WORKS, BARNBURY.

## UNIVERSITY OF ABERDEEN.

Academical Year, 1922-1923.

## FACULTIES OF SCIENCE AND MEDICINE.

Winter Session commences on Wednesday, October 11, 1922, and closes on Friday, March 16, 1923.

Summer Session commences on Monday, April 23, 1923, and closes on Friday, June 2, 1923.

The Preliminary Examinations will commence on Friday, September 15, 1922, and Friday, March 9, 1923.

## FACULTY OF SCIENCE.

The Faculty of Science embraces 8 chairs besides Lecturers by whom instruction is given in all the main departments of the Science School.

## PROFESSORS.

Natural Philosophy  
Physiology  
Anatomy  
Natural History  
Mathematics  
Agriculture  
Chemistry  
Botany  
Geology

John Alex. MacWilliam, M.D., F.R.S.  
Robert William Reid, M.D., F.R.C.S.  
John Arthur Thomson, M.A., LL.D.  
Hector Munro MacDonald, O.B.E., M.A., F.R.S.  
James Hendrick, B.Sc.  
Alexander Findlay, M.A., D.Sc., Ph.D.  
William Grant Craib, M.A., F.L.S., F.R.S.E.  
Alfred Wm. Gibb, M.A., D.Sc.

## LECTURERS.

Veterinary Hygiene  
Physics  
Engineering Field Work  
Forestry  
Agriculture  
Parasitology  
Forest Botany and  
Forest Zoology

William Brown, M.R.C.V.S., F.R.P.S.  
Ph. A. W. Fulton, M.D.  
Vacant.  
Peter Leslie, M.A., B.Sc., B.Sc. (Agr.).  
Wm. J. Profeit, M.A., B.Sc. (Agr.).  
John Rennie, D.Sc.

Alex. S. Watt, M.A., B.Sc. (Agr.).

The Degrees conferred by the University are:—

Bachelor of Science in Pure Science (B.Sc.).  
Bachelor of Science in Agriculture (B.Sc. Agr.).  
Bachelor of Science in Forestry (B.Sc. For.).  
Doctor of Science (D.Sc.).

Diplomas in Agriculture and Forestry are also granted. The Inclusive Fee for instruction for the B.Sc. in Pure Science is 50 Guineas, payable in three annual instalments of 30 Guineas.

The Degree Fee is 2 Guineas, payable 4 Guineas for the first examination and 5 Guineas for the second examination. Practical work in agriculture is carried out in conjunction with the North of Scotland College of Agriculture, which has a demonstration estate a few miles out of Aberdeen.

A number of Bursaries and Scholarships are awarded in Pure Science and in Agriculture.

## FACULTY OF MEDICINE.

The Faculty of Medicine embraces 12 Chairs. Instruction in special departments of Medical practice is given by Lecturers appointed by the University Court. Clinical instruction is obtained in various Hospitals and Institutions in Aberdeen.

The Degrees in Medicine granted by the University are:—  
Bachelor of Medicine and Bachelor of Surgery (M.B. & Ch.B.).  
Doctor of Medicine (M.D.).  
Master of Surgery (Ch.M.).

A Diploma in Public Health is conferred after examination on graduates in Medicine of any University in the United Kingdom. The total cost of the whole curriculum for the Degree of M.B., Ch.B., including Hospital Fees, Matriculation Fees and Degree Fees, is approximately about £248.

The University also grants Degrees in Arts, Law, Divinity, Education and Commerce.

Further particulars may be had on application to the SECRETARY of the University, Marischal College, Aberdeen.

H. J. BUTCHART, Secretary.

## TECHNICAL COLLEGE, BRADFORD.

## DAY COURSES.

Full-time (Day) Courses, extending over three or four years, and leading to the Diploma of the College, are arranged in the following departments:—

TEXTILE INDUSTRIES. MECHANICAL ENGINEERING.  
CHEMISTRY. CIVIL ENGINEERING.  
DYEING. ELECTRICAL ENGINEERING.  
BIOLOGY.

Special facilities are available for Advanced Study and Research.

## EVENING COURSES.

Part-time (Evening) Courses are also arranged, on the successful completion of which students are awarded Senior and Advanced Course Certificates.

Further particulars and prospectuses may be obtained on application to THE PRINCIPAL, TECHNICAL COLLEGE, BRADFORD.

## UNIVERSITY OF BIRMINGHAM.

## FACULTIES.

Science: Subjects—Mathematics, Physics, Chemistry, Zoology, Botany, Geology, Engineering (Mechanical, Civil, Electrical), Metallurgy, Mining (Coal, Metal, Petroleum), Bio-Chemistry of Fermentation.

Arts: Subjects—Latin, Greek, English, French, German, Italian, Spanish, Russian, Philosophy, History, Music.

Medicine: All subjects leading to Degrees and Diplomas in Medicine and Dentistry.

Commerce: Subjects leading to Degrees in Commerce.

Department of Training for Teachers.

Department of Social Study.

Department of Malting and Brewing.

THE SESSION 1922-23 COMMENCES ON  
OCTOBER 2, 1922.

ALL COURSES AND DEGREES ARE OPEN TO BOTH MEN AND WOMEN STUDENTS.

In the Medical School Courses of Instruction are arranged to meet the requirements of other Universities and Licensing Bodies.

Graduates, or persons who have passed Degree Examinations of other Universities, may, after one year's study or research, take a Master's Degree.

Separate Syllabuses with full information as to Lecture and Laboratory Courses, Fees, Regulations for Degrees, Diplomas, &c., Exhibitions, and Scholarships, are published as follows:

1. Faculty of Science.
2. Faculty of Arts.
3. Faculty of Medicine.
4. Faculty of Commerce.
5. Department of Social Study.
6. Department of Biology and Chemistry of Fermentation.
7. Exhibitions, Scholarships, &c.,

and will be sent on application to the REGISTRAR.

UNIVERSITY OF LONDON,  
KING'S COLLEGE.

## FACULTY OF ENGINEERING.

Complete COURSES OF STUDY, extending over either three or four years, are arranged in

## CIVIL, MECHANICAL AND ELECTRICAL ENGINEERING

for the Engineering Degrees of the University of London, and for the Diploma and Certificate of the College.

The four years' Course provides, in addition to the academic training, opportunity for practical training in "Works."

## HEADS OF DEPARTMENTS.

Professor G. COOK, D.Sc., A.M.Inst.C.E., A.M.I.Mech.E., Mechanical Engineering.

Professor A. H. JAMESON, M.Sc., M.Inst.C.E., Civil Engineering.

Professor E. WILSON, M.Inst.C.E., M.I.E.E. (Dean), Electrical Engineering.

Professor S. A. F. WHITE, M.A. } Mathematics.

Professor G. H. JEFFERY, M.A., D.Sc. } Chemistry.

Professor A. MULLER-SMILES, O.B.E., D.Sc., F.I.C., F.R.S. } Chemistry.

Professor A. J. ALLMAND, M.C., D.Sc., F.I.C. } Chemistry.

Professor O. W. RICHARDSON, D.Sc., F.R.S., Physics.

Professor W. T. GORDON, D.Sc., F.R.S.E., Geology.

Considerable extensions have been made in the Engineering Department. These include a large additional Drawing-Office, Lecture-Room, and Laboratory for Hydraulics and Strength of Materials in the Civil and Mechanical Departments; and Research Rooms, including Wireless Telegraphy, in the Electrical Engineering Department. Large additions have been made to the equipment of the Laboratories in the three Departments for purposes of Teaching and Research.

There is a College Hostel and a large Athletic ground. For full information apply to THE SECRETARY, King's College, Strand W.C.2.

## CITY OF LONDON COLLEGE,

WHITE STREET, AND ROPEMAKER STREET,  
MOORFIELDS, E.C.2.

## Department of Commercial Products.—Mr. S. J. DULY, M.A.

EVENING CLASSES in CHEMISTRY and products, including cereals, iron and steel, oil seeds, textiles and timber, suitable for those engaged in houses dealing in these products. Particulars on application to DAVID SAVAGE, Secretary.



SATURDAY, AUGUST 19, 1922

## CONTENTS.

	PAGE
Radio Broadcasting in Great Britain	237
University Education in London. By T. L. H.	240
Antarctic Foraminifera. By G. H. C.	241
Water Underground. By Prof. Grenville A. J. Cole, F.R.S.	242
Statics, Dynamics, and Hydrodynamics. By Dr. S. Brodetsky	243
Our Bookshelf	245
Letters to the Editor:—	
The Acoustics of Enclosed Spaces.—Sir Arthur Schuster, F.R.S.	247
Some Spectrum Lines of Neutral Helium derived theoretically.—Dr. Ludwik Silberstein	247
The Primitive Crust of the Earth.—Prof. Grenville A. J. Cole, F.R.S.	249
Peculiarities of the Electric Discharge in Oxygen.—Rev. Dr. P. J. Kirkby	249
Defoliation of Oaks.—E. W. Swanton	250
Scorpions and their Venom.—Major C. E. F. Mouat-Biggs	250
Bloomsbury.—Dr. A. Morley Davies; T. L. Humberstone	250
Absorption of Potassium Vapour in the Associated Series.—Prof. A. L. Narayana and D. Gunnaiya	250
A Recording and Integrating Gas Calorimeter. ( <i>Illustrated.</i> ) By Dr. J. S. G. Thomas	251
The Earth's "Crust" and its Composition. By Thomas Crook	253
Centenary of the Death of William Herschel	255
Obituary:—	
Dr. Arthur Ransome, F.R.S.	256
Prof. Gisbert Kapp. By A. R.	257
Mrs. J. A. Owen Visger	257
Prof. H. Battermann. By A. C. D. C.	258
Current Topics and Events	258
Our Astronomical Column	260
Research Items	261
The Hull Meeting of the British Association: Programmes of the Sections	26
The Imperial Cancer Research Fund	266
European Fish in New Zealand Waters	266
University and Educational Intelligence	267
Calendar of Industrial Pioneers	267
Societies and Academies	268
Official Publications Received	268

*Editorial and Publishing Offices:*

MACMILLAN & CO., LTD.,

ST. MARTIN'S STREET, LONDON, W.C.2.

Advertisements and business letters should be addressed to the Publishers.

Editorial communications to the Editor.

Telegraphic Address: PHUSIS, LONDON.

Telephone Number: GERRARD 8830.

## Radio Broadcasting in Great Britain.

THE delay which has arisen in connexion with the inauguration of the proposed provision of a comprehensive radio broadcasting scheme in the British Isles has caused questions affecting the policy the Government should pursue in relation to broadcasting to be widely ventilated, and has, at the same time, directed attention to the great variety of interests that are involved in this matter. In view of the immense importance of radio-telegraphy to-day in connexion with measures affecting national defence, and of the fact that this means of communication is easily susceptible of interference from accidental causes as well as those of wilful design, it is the duty of the Government to ensure that the radio interests in its own care shall be properly safeguarded in the new situation which has come into existence in the wireless field.

Hitherto the authority and powers under which the Government has exercised control in relation to radio-telegraphy are those which it has derived under the Wireless Telegraphy Act, 1904 (4 Ed. 7, c. 24)—hereinafter referred to as the principal Act—a temporary Act which was placed on our Statute Roll a very few years after the practical utility of radio-telegraphy was first demonstrated, and has since been re-enacted in its original form from time to time as required. With the progress of time the need for governmental control in this field has in no way abated. Early in this year, about the same time that broadcasting first prominently attracted public attention, the Government took steps to strengthen its position by introducing the Wireless Telegraphy and Signalling Bill (12 & 13 Geo. 5—No. 148) in the House of Commons: therein provision is included for placing the principal Act permanently on the Statute Roll and, at the same time, for greatly enlarging the powers hitherto enjoyed by the Postmaster General. Under these new provisions the Government will undoubtedly possess extremely large powers, but probably not larger than are required to enable it effectively to cope, in the general interest of the public, with the wireless situation in this country. It is unfortunate, then, that a suspicion should have arisen in some quarters that the new powers may possibly be misused by the Government in their application to broadcasting: particularly is this so as many conflicting interests are involved in connexion with the putting into operation of broadcasting services, and therefore, in pursuing its policy, the Government needs to secure the fullest confidence of the several groups affected.

Indications have already been given as to the policy

which the Government intends to follow with regard to certain aspects of broadcasting. The decision of the Government to leave this branch of wireless activity in the hands of private enterprise to develop, has been widely welcomed: however, fears have been expressed lest, in giving effect to its policy under a licensing system, the Government may allow an industrial monopoly to grow up. It has to be borne in mind that the situation under discussion is altogether an exceptional one, and that although a complete monopoly cannot be tolerated, on the other hand, as is the case with ordinary telegraphy and telephony, and, indeed, with many other public utility services, so in the case of radio broadcasting, the field is not one which lends itself to unlimited competition; for, on purely technical grounds, a limitation has to be placed on the liberty of free competition in those cases where the radiation through space of electro-magnetic waves for signalling purposes is involved.

This latter point requires to be emphasised, as a proposal has been seriously put forward that, in spite of the grave risks of mutual interference incurred thereby, full liberty of action should be permitted to those whose wish it is to develop and trade in radio broadcasting, rather than that a complicated system of licences and supervision should be introduced. But full liberty of action is not feasible here: radio broadcasting cannot, on the transmission side, be conducted untrammelled by bureaucratic restrictions. The removal of such restrictions would not only defeat the aims of those who are seeking to establish useful, efficient and continuous broadcasting services in the British Isles, but would also, at the same time, put in serious jeopardy the radio communication services established in connexion with our national defence arrangements, as also the commercial services already in existence. For practical reasons, it is found necessary to lay down a definite upper limit to the number of radio transmitting stations which may be erected within a particular region. In the British Isles, the number of radio services of the several kinds connected with the fighting services and required for commercial purposes are already so great, that a central governmental authority has had to be created in order effectively to regulate the situation: it determines and allocates the radio wave-lengths that shall be utilised for particular purposes.

It is on the advice of this authority that the Government will, so far as the technical aspects of the situation are concerned, be obliged to act. In the matter of competition there are, of course, apart from the technical considerations referred to, financial aspects also which have to be brought under review. Normally it certainly is not the function of the Government to

attempt to control the financial side of a private enterprise. However, so far as broadcasting is concerned, the Government is committed, *volens volens*, to a certain measure of control of the organisations about to be licensed for this purpose; therefore, so long as everything is done to allow of the fullest amount of competition permissible in this field at the present time, and to admit of an increase of this competition in the future should technical and other considerations permit this safely to be done, it would not be unreasonable, at the present juncture, for the Government to exercise such further control as may be required to prevent anything being done the inevitable result of which would be the almost immediate destruction of a part of the capital of the investing public. On the other hand, by playing a part, as is proposed to be done by the Postmaster General, in the framing of the articles of association of the companies which it is intended to license for providing broadcasting services, the Government is likely, at some future date, to be deprived, wholly or partially, of its liberty to modify its policy in relation to competition should this be feasible, and desirable in the public interest, and it may thus lay itself open later to the charge of having allowed a monopoly to come into existence. It is at this stage that care should be taken by the Government to guard against entanglements which may afterwards prove embarrassing.

In the case of receiving apparatus the technical situation is relatively a simple one, and there is every reason for permitting the fullest competition in dealings connected therewith. It is desirable, therefore, that individuals wishing to possess such apparatus should have the greatest latitude allowed them in procuring what they want. Announcements have appeared that the types of apparatus to be used in connexion with broadcasting must conform to certain technical standards approved by the Post Office: if this merely means that the Post Office will issue a general specification, no objection can be taken. However, if it is intended that manufacturers must submit to the Post Office for its approval the designs of the apparatus they propose to put on the market for broadcasting, a serious mistake is being made alike from the manufacturers' point of view as of that of the Post Office, which will thus be saddling itself with a responsibility that it should seek to avoid. In the interests of all parties, it would seem best that the sale and purchase of wireless receiving apparatus should be carried on in these islands on the customary commercial lines free from restrictions of all kinds. It follows, therefore, that whoever may so desire should be permitted to make use in his or her broadcasting receiving installation of any home-made apparatus, provided that the same complies with the general technical requirements laid down officially.

It has been announced that the Postmaster-General is in favour of subsidising the organisations which are to be licensed for broadcasting purposes out of fees to be collected on the licences issued in connexion with wireless receiving stations. The situation is one which requires to be carefully handled, if mischief is not to be done. The authority given to the Postmaster-General to grant and renew licences in connexion with radio receiving apparatus exists primarily, not for revenue-raising purposes, but for that of effecting the registration of wireless installations of every kind ; a step which is necessary as a measure of police precaution and also for facilitating control over all individuals using radio receiving sets. Since the law requires every person with a wireless installation to take out a licence, the charge for the same should be kept as low as possible. At the same time, it is reasonable that those who desire habitually to avail themselves, for one reason or another, of broadcasting services should be expected to contribute towards the cost of the same : strictly, this contribution should depend upon the extent of the user. The situation is one that lends itself to treatment by the grouping of the licences, on some practical basis, into two easily distinguishable categories, and by a differentiation in the charges to be levied on the licences in these two categories.

Now, broadcasting is essentially a luxury demand, and it has to be borne in mind that there are to-day, and will always be, many owners of licensed wireless installations who are not desirous, as a practice, of making use of broadcasting services. For this reason, anything in the nature of a general levy on all wireless receiving stations must be avoided. On its merits, broadcasting is deserving of the fullest encouragement and the greatest assistance which the Government can give it, alike in the interests of those who seek amusement therefrom, of the research workers in this field, and of the electrical industry. It seems improbable that any sum likely to be raised at the present time by fees on the grant and renewal of licences will go anywhere near providing the contemplated annual outlay on the broadcasting scheme which has been projected. It has been estimated that an outlay of 180,000*l.* per annum<sup>2</sup> will be involved in connexion with the proposed broadcasting stations. Now, there are at the present time in this country some 10,000 holders of licences for wireless receiving installations. In view of the relatively high cost of providing complete receiving installations, an increase in the number of licences may, in these days of trade depression, be a slow matter ; but assuming that an immediate increase may multiply their number tenfold, even so, approximately 2*l.* per annum would, on a flat-rate basis, have to be levied on every licence,

<sup>2</sup> See NATURE for August 5, p. 197.

in addition to the registration fee, if the whole annual cost of the broadcasting stations is to be met in this way. There is, however, a serious risk that an annual contribution on this scale may have the effect of retarding materially the rate of the growth in the number of private wireless installations.

In these circumstances, it would seem that the licensed organisations will be well advised to endeavour to raise the annual revenue they require largely from audiences attracted to public entertainments promoted and run under their auspices : evidence exists tending to show that large audiences can be attracted to broadcasting entertainments of a high class. The licensed organisations can, of course, at the same time, raise additional revenue by hiring out wireless receiving installations for entertainment purposes, by sales of apparatus outright, and by other means. It is in relation to the carrying out of this wider policy, which caters for the needs of all classes interested in radiotelegraphy, that the Government can best help in popularising broadcasting and aid in promoting the commercial success of licensed organisations rather than in the attempt to subsidise them out of moneys raised by means of fees charged on licences, the amount of which may, more than likely, prove extremely disappointing. For example, the Government can, on the technical side, help the licensed organisations materially by allotting to them the necessary number of suitable radio wave-lengths to enable them to carry out their programmes, and in many other incidental ways : it can also to some extent afford them assistance on the commercial side by causing all applications for entertainment licences to be collected by them for transmission to the Postmaster General, a course the adoption of which would provide the licensed organisations with opportunities for selling broadcasting services, whilst at the same time promoting genuine competition in this field.

In connexion with broadcasting, other rights are threatened, such, for example, as copyright and patent right. In all the circumstances of the present situation, it behoves the Government then to keep itself as free as possible from responsibility in connexion with the details of the radio broadcasting services. This it will do so long as it confines its rôle to that of a licensing authority exercising general control and supervision over the purely wireless situation, and by allowing, in collateral matters, the old doctrine to prevail, that where the likelihood of the invasion of the legal rights of others is involved, every subject in the realm acts at his own peril and must be held personally answerable for his own deeds to him who establishes in due course of law that he has suffered an injury from an actionable wrong at the hands of another.

### University Education in London.

*The University of London (History, Present Resources and Future Possibilities).* By Sir Gregory Foster. Pp. 48. (London: University of London Press, Ltd., 1922.) 1s. 6d. net.

THE Provost of University College has been well advised to publish in the form of a pamphlet, attractively printed and illustrated, the two lectures delivered at the College in February last, together with the speech of the president of the Board of Education (Mr. Fisher) at the conclusion of the second lecture. A less ambitious title might perhaps have been chosen, for in effect the lectures are a closely reasoned apology for the Bloomsbury site and for the University policy which it represents. At the outset, the popular illusion that University education in London is to be concentrated entirely in one quarter is examined and dismissed. The sites alone of the thirty-six Colleges of the University occupy no less than 212 acres and their students number 21,600. Their halls of residence account for  $7\frac{1}{2}$  acres and their playing fields for another 215 acres, making a grand total of 434 $\frac{1}{2}$  acres. To bring together these vast educational resources would be a prodigious undertaking—extravagant (a "wanton waste" as the Provost says), impracticable by reason of the necessary contiguity of the medical schools to their hospitals, and undesirable in an educational sense. Other less fortunate Universities have discovered that it is impossible to educate in crowds. The Provost's arguments against carrying the "concentration" idea too far are complete and unanswerable.

One asks at once why if a large dose of the medicine is fatal, a homœopathic dose should be beneficial—in other words, why the Government should urge so strongly the removal of King's College to the Bloomsbury site. "It is," says the Provost, "for the obvious reason that King's College on its present site, delightful as it is from many points of view, cannot grow and extend according to its needs." This argument is hardly relevant, for there are other parts of London than Bloomsbury where King's College could grow if that is what it wishes to do. The question of the *optimum* size for a college is involved; and there are other ways of growing, it may be suggested, than in size and numbers—in efficiency, for example, or by planting out part of its work as King's has done already in the case of its Household Science Department at Campden Hill. The impression left on the mind of the reader of these discourses must be that the King's College question is not discussed with force or conviction.

There is a peculiar habit in University circles in

London of continuing the argument after a conclusion has been reached. From this point of view the Provost's carefully compiled statistics in favour of the Bloomsbury site will fortify the loyal forces in the guerilla warfare which is now being waged with vigour and persistence. Of the total of 21,634 students in the Colleges of the University, no less than 16,764 are in Colleges within two miles of the Bloomsbury site, whereas the corresponding figure for the rival Holland Park site is only 1520. The number outside the two-mile radius of either site is 3306. Whether the two-mile radius was chosen because of the distance covered by the *rd.* bus fare of a happier generation, we cannot determine; but we may fairly ask why the University quarter should be within this reasonable distance of the students, seeing that except for compulsory attendance at examinations they have in recent years found no pleasure in visiting the University headquarters. On the only occasion on which the present writer remembers to have seen a thousand London students in one room, their object in coming together was to denounce the existing constitution of the University!

On this question the Provost maintains a strange silence. He fails to stress the need which exists in London for the active encouragement of all those social, athletic, and extra-academic influences which make for the development of students' personality as distinct from intellect. The Bloomsbury site should provide these facilities as far as practicable in the form of dining-halls, clubs, hostels, accommodation for debates and meetings of extra-academic societies, theatres, concert-rooms, art galleries, museums, gymnasia, fives courts, swimming baths, churches, and mosques! Unless something can be done on these lines, the whole discussion is meaningless from the point of view of the students regarded as human beings and not merely as statistical units.

For administrative purposes and for ceremonial and public meetings of all kinds, the need for a central position is paramount and incontestable. Busy public men, administrators, and teachers who do voluntary work as members of University Committees may reasonably demand that their sacrifice of time and money in travelling shall be reduced to a minimum. A few weeks ago some five hundred graduates attended a meeting of Convocation at South Kensington for the purpose of electing a new chairman. At the lowest computation 10*l.* extra was spent in travelling to South Kensington as compared with, say, Bloomsbury; more important and serious, the meeting must have been less representative because of the inability of graduates living or working on the remote side of London to attend. How any person of common sense or knowledge of London can argue that South Kensing-

ton or Holland Park is conveniently situated for a University quarter passes comprehension.

It would be unfair to expect in the course of two lectures a full exposition of University policy; but there appears to be some lack of consistency, possibly more apparent than real, between the criticism of pre-1900 higher education in London when "each college made its own plans and did its own work in the best way it could" and the current demand that, a teaching University having at last been established, certain Colleges shall be given the status of "Dominions" enjoying Home Rule within the University. If University and King's Colleges were set up cheek by jowl on the Bloomsbury site, the need for co-ordination by some independent and impartial authority would cry out to heaven. The Provost is on surer ground in pleading for "as much concentration in the University Quarter as is practicable," especially in respect of "all the new post-graduate institutes," and our only criticism of this proposal is that a more comprehensive term than "post-graduate institutes" should be used. In addition to post-graduate institutes, there is need for a number of schools or institutes of a specialised character, e.g. for law, music, drama, journalism, and military science, to specify only a few subjects for which at present provision is not made or is inadequately made within the University. As an instance of a post-graduate institute, the new scheme for an Institute of Public Health is cited, and it is gratifying to find that the demand for Collegiate Home Rule is not in this case interpreted by the Provost in the sense of "what we have we hold." "We have a department [of Hygiene] in this College, the oldest in the country, but it is inadequate to meet the needs of London; and we should be prepared to see that department, and all the still smaller departments in the other Colleges, merged into one great institute. That is the kind of development which will be helped by the concentration in Bloomsbury."

Towards the conclusion of the lectures, the Provost pleads for "the necessary spirit to pull and work together" in order to substantiate the vision of a great University of London which he has somewhat faintly adumbrated. These wise words should not be received in a derisive spirit. No one will suppose that University College has attained its present great prestige without a struggle, or that on certain occasions its rivalry with other Colleges may not have taken a combative form. The important thing to ensure, as the Provost suggests, is that this rivalry, unavoidable and even desirable within limits, shall be as free as possible from selfishness—"particularism" is the polite academic word—with the greater glory of the University always in view, magnanimous, void of envy, malice,

and intrigue, and of that perverted form of academic freemasonry which suspends private judgment and exalts College loyalty. The alternative is constant suspicion and bitter, often unreasonable, opposition to progress.

A brief reference must be made in conclusion to Mr. Fisher's speech delivered at the end of the second lecture. He found himself in "full agreement with the admirable doctrine contained in the address." The University of London was a species by itself.

"The Government, four years ago, made an offer of the Bloomsbury Site to the University of London. That offer has been accepted by the University. The Government do not propose to make another offer, and if the University does not like the site, well, it can return it to the source from which it came. I have no doubt the Chancellor of the Exchequer will appreciate its generosity."

The limit to the number of students who could be educated at Oxford and Cambridge had been reached, and London must be prepared to receive a great influx of students, particularly

"from the Dominions, from India, from the Crown Colonies, from the United States of America, and from the allied Powers of the Continent." You must concentrate in one part of London "not all the teaching power, but an impressive proportion of the teaching power," and that was "the principal object which the Government had in view in suggesting an arrangement under which King's College could be brought into close proximity with University College." And as last words he said: "Let those who are anxious for the future of London University, from whatever angle they may have hitherto viewed London University problems, let them concentrate on the endeavour to create upon the site a noble series of buildings, worthy of the reputation of the University, worthy of its past, and adequate to the great destinies which await it."

T. LL. H.

### Antarctic Foraminifera.

*British Museum (Natural History). British Antarctic ("Terra Nova") Expedition, 1910. Natural History Report. Zoology, Vol. 6, No. 2. Protozoa, Part 2: Foraminifera.* By Edward Heron-Allen and Arthur Earland. Pp. 25-268 + 8 plates. (London: British Museum (Natural History), 1922.) 30s.

STUDENTS of natural history in its wider aspects will welcome the appearance of this memoir on the Antarctic Foraminifera of the second Scott Expedition—a notable contribution to the series of reports which have resulted from the *Terra Nova* Expedition. The authors state that the material collected during the expedition was placed in their hands seven years ago, and that the delay in publication has been due, not

only to the difficulties of biological research in war-time, but also to the method of preservation adopted for most of the dredgings containing foraminiferal specimens. The collectors appear to have put unwarranted confidence in formalin, "than which no more unsatisfactory medium for . . . Foraminifera can be imagined." Messrs. Heron-Allen and Earland have been compelled, therefore, to expend much time and trouble in cleaning the material entrusted to them so as to render it at all suitable for study, and they "can only review the results as a tantalising sketch of the possibilities which would have attended upon an ample supply of properly collected Antarctic material." Nevertheless, the authors are able to record 650 species and varieties of these fascinating Protozoa, of which 46 are new to science.

In looking through the systematic list, which occupies by far the greater part of the memoir, the student of distribution cannot but be impressed by the wide range of many of the types. Species recorded here from the far south are identical with those, already enumerated in lists by the same authors, of Foraminifera from the North Sea, and from the Atlantic waters around the shores of Conacht. Several types are common to Arctic and Antarctic regions, but these are almost all pelagic forms, and capable of the most extensive migrations. The only exception, *Globigerina pachyderma*, Ehrenberg, with its "curiously thick-walled" shell, is "the typical *Globigerina* of Arctic deposits," reaching its southern limit about the Faeroe Channel. Nevertheless, the authors do not consider that its presence in the Antarctic Ocean affords any support to the once-popular "bipolarity" theory of specific origins. Apparently *G. pachyderma* is "a local variation" of *G. dutertrai*, d'Orbigny, a transition from the one form to the other being clearly demonstrable as dredgings from more southerly stations are examined. This transition is supposed to be "induced by conditions of temperature," and the authors believe that "the same gradual transition [from *G. dutertrai* to *G. pachyderma*] which we have described in the Antarctic could be traced in the Arctic and temperate seas."

Systematic students of the Foraminifera will be especially interested in the number of hyaline species of which arenaceous isomorphs are described—for example, *Bifarina porrecta* (Brady), *Bolivina punctata*, d'Orbigny, and *Rotalia soldanii*, d'Orbigny. The authors express their agreement with Bütschli, Fauré-Fremiet, and other recent workers at the order, in considering that the existence of such isomorphs—the formation of an arenaceous instead of a calcareous test due to some obscure physiological reaction—may necessitate ultimately a revision in the classification of the Foraminifera. "We do not think the time has

yet arrived to abandon the generally accepted, if artificial, system of Brady, which, with some modifications, is followed in this Report. But we have endeavoured to clear the way towards a proper zoological allocation of the Lituolidae by refraining wherever possible from the creation of new arenaceous species, and retaining our new arenaceous forms in the genera to which they naturally belong."

Among the newly described forms the genus *Dendronina*, referred to the *Astrorhizidae*, comprising two New Zealand and two Antarctic species, is noteworthy. The test is built of fine mud, sand-grains, and sponge-spicules, and the sessile *D. arborescens* assumes a complex branching habit, attaining a height of 5 to 6 millimetres. The authors believe that the genus may be represented also in tropical seas (Indian Ocean). *Polytrema miniaceum* (Pallas) was found in great abundance in the New Zealand area, at one station "practically every solid organism" being "more or less covered with it." It is a sessile foraminifer of very wide range, and the authors have made a special journey to Corsica so as to study the species in life in Mediterranean waters. The organism in its early free stage settles on some object, wherewith it gains connexion by thrusting out protoplasm from its under surface and forming "a thin layer of incrusting chambers." The protoplasm subsequently streams out from these, surrounds the young spherical test, and constructs a wall of small chambers which overgrow and envelop the latter. Finally the characteristic branching, arm-like processes grow out. The occurrence of siliceous sponge-spicules inside the chambers of the *Polytrema* has given rise to much discussion; the authors have observed sponge and foraminifer "close together and approximately the same size," and do not altogether reject the possibility of a true symbiosis.

In order to reduce the cost of publication, the authors have restricted to a minimum their synonymic references. The eight plates illustrating the memoir have been admirably drawn by Mr. M. H. Brooks and are excellently reproduced. All the workers concerned may be heartily congratulated on the results made known in this most recent outcome of Antarctic exploration and research. G. H. C.

### Water Underground.

*Nouveau Traité des eaux souterraines.* Par E.-A. Martel. Pp. 838. (Paris: G. Doin, 1921.) 50 francs.

IN M. Martel's treatise, stress is naturally laid on what he has styled "speleology." For him, subterranean water moves in a fascinating world of caves. The conception of a general water-table in



permeable rocks does not appeal. His conclusions as a follower of water by sheer hard climbing and exploration underground are supported by the very varied results of borings made near one another in beds regarded as porous by the engineer. M. Martel believes, with much justice, that subterranean rivers do not etch out their own way; they are determined by pre-existing crevices, the *diaclases* of Daubrée. In the case of limestone, solution obviously widens the original fissure; but it must have been generally recognised that the long-continued dominance of the joint-system is again and again revealed in the plans of sinuous caves.

M. Martel, however, does not give geologists much credit for observing a relation between the direction of surface-streams and the fissured structure of a country; but we cannot help remembering the account of the Drava and Gail system in the first volume of Suess's "Antlitz der Erde," and the exposition by Molyneux and Lamplugh of the Batoka Gorge of the Zambezi. In the case of Mosi-oa-tunya, however, M. Martel seems satisfied with the somewhat catastrophic views of Livingstone. We must admit that an examination of our ordinary text-books reveals an unfortunate silence on this question of fissures and stream-erosion; but surely M. Martel is inclined to exaggerate (p. 42) the differences between his views and those of colleagues like Lugeon, Kilian, and de Martonne. He is accustomed to move adventurously in narrow rift-like ways, along the floors of ravines and their counterparts underground; but he cannot wish us to return to the antique view of valleys as gaping fissures in the crust. On a tilted peneplain the courses of streams are at first uncertain; they are controlled merely by the general slope. When they have worked down into the surface of solid rock, they at once begin to be guided by the joints, the lines of weakness. The walls of the ultimate valleys are due to erosion; the general ground-plan is often determined by that of the joints, the walls of which are practically in contact until the streams begin to work.

The surface-waters then cut downwards. By seepage they become subterranean, and the *diaclases* prove still more effective in the underworld. The details of caves and of disappearing and reappearing streams are never monotonous to M. Martel; but the frequent photographic representation of them may pall a little on the geological or engineering reader. We must admit that the pictures here given, to the number of three hundred, are fascinating and often very impressive. In some cases, as in those of the cañon of Ouhadibie in the Basses-Pyrénées, they result from very recent exploration.

The discussion of the origin of water in the Chalk

(p. 366) raises important engineering considerations. Mr. R. L. Cole has recently dealt with this matter as regards the south of England ("The Power User," June 1922, p. 97), and he treats the body of the Chalk as providing little opportunity for flow. M. Martel, in his descriptions of "lapiaz" or "lapiés" (p. 531), shows well how water penetrates a limestone surface and how it proceeds to ramify below. His remarks on the use of the divining-rod (p. 749) are philosophic and reserved; he looks for a very extended series of trials made on a consistent plan. The power of divination, if it exists, resides in the operator and not in the instrument used. He shows, among other interesting matters, how the sinking of artesian wells was known to dwellers on the edge of the Sahara centuries before Moorish engineers were invited to find water in Artois. The ease with which subterranean water may be contaminated is attested by grim instances (p. 767) of the slow decomposition of corpses interred on the battlefields of 1914-18, and by the infection during a whole year of the spring of Gerbéviller in Lorraine.

GRENVILLE A. J. COLE.

### Statics, Dynamics, and Hydrodynamics.

- (1) *Elementary Statics of Two and Three Dimensions*. By R. J. A. Barnard. Pp. vii + 254. (London: Macmillan and Co., Ltd., 1921.) 7s. 6d.
- (2) *Theoretical Mechanics: An Introductory Treatise on the Principles of Dynamics, with Applications and Numerous Examples*. By Prof. A. E. H. Love. Third Edition. Pp. xv + 310. (Cambridge: At the University Press, 1921.) 30s. net.
- (3) and (4) *Idromeccanica Piana*. By Prof. Umberto Cisotti. Parte Prima. Pp. xii + 152. Parte Seconda. Pp. viii + 155-373. (Milano: Libreria Editrice Politecnica, 1921.) Lire 24 and 32 respectively.

(1) **P**ROF. BARNARD'S new book makes an excellent text-book for the higher years in pass degree courses and for the first part of honours courses in applied mathematics. The scope is that generally expected, a chapter on forces in three dimensions being included. In treatment the book is orthodox and safe, so orthodox in fact that centres of gravity are left to quite a late chapter, as if the finding of centres of gravity were an aim in itself. The proof of the vector property of couples is very effective.

A chapter is added on vectors in space, use being made of the vector notation, and the student is referred to the author's "Dynamics" for a fuller treatment. The modern student of mechanics and physics cannot afford to be quite ignorant of vector methods and notation, and Prof. Barnard is performing a useful

service by including them in his books, even if only in the form of an afterthought.

(2) Prof. Love's "Theoretical Mechanics" is a book that serious students of dynamics cannot be without: the discussions of the principles are illuminating, and the collections of examples are useful to both teacher and pupil. Only a few changes have been made in the recently issued third edition. Perhaps it is permissible to suggest that the book would be immensely more useful if it partook of the nature of a text-book, and included a much larger number of worked examples. The student's main difficulty in dynamics is not in learning the comparatively restricted number of ideas and methods given in the usual honours courses, but rather in obtaining the necessary experience for using these ideas and methods successfully in the problems presented by nature. By far the most effective help that can be given him is that contained in a judiciously selected and carefully graduated series of worked problems, where the efficiency value of each process is made evident.

As the author emphasises the importance of the fundamental principles, the volume would be the right place for a brief account of relativity in dynamics. To leave this latest phase of modern scientific reform to the physicist and the philosopher is a mistake that applied mathematicians should endeavour to counteract.

Publishers no doubt know their business and do not need the advice of academic men. A protest must nevertheless be raised against excessive prices. The price of this new edition will prevent its sale among just those young students whose mechanical ideas the author wishes to influence.

(3) and (4) The study of two-dimensional problems is of great interest in several branches of applied mathematics, as, for instance, in potential theory, electricity, and hydrodynamics. It often happens that when a three-dimensional problem of importance cannot be solved, the two-dimensional case is amenable to modern mathematical methods and its solution sheds much light on the general problem. This has been the case particularly in hydrodynamics.

The present volumes are the first two parts of a treatise on two-dimensional hydrodynamics. Part I. gives the theory of the complex variable and conformal representation, which is followed by a statement of the equations of motion of a fluid in two dimensions. Problems with boundaries consisting of free stream lines only, and with boundaries consisting of fixed barriers only, are then discussed. Part II. deals with jets and other problems, involving both fixed and free boundaries, while Part III. will deal with wave-motion.

Of the different types of problems discussed by Prof. Cisotti, perhaps the most interesting is that of

discontinuous motion of fluid past a fixed barrier—a problem that has some bearing on the modern subject of aerodynamics. When the barrier is plane, and the motion is assumed to be irrotational, with free stream lines, the problem has been solved by the use of what constitutes one of the most elegant processes of mathematical reasoning. Curved barriers, however, have so far defied solution, except in the sense that when a solution is suggested one can obtain equations which define the barrier appropriate to the solution. The problem of the curved barrier may almost be described as one of the classical problems of hydrodynamics. Several interesting cases have been discussed, in particular by Prof. Cisotti himself, Villat, and others.

The ordinary text-book process of solving two-dimensional problems in hydrodynamics is to seek a relation between the complex variable that represents the geometry of the actual motion and the complex variable involving the velocity potential and the stream-line function. An intermediary variable, which is essentially representative of the velocity vector, is often useful. In dealing with discontinuous motion past barriers consisting of plane surfaces, a further intermediary variable is needed, based on the Schwartz-Christoffel transformation: the problem is then reduced to quadratures.

For curved barriers, however, this is insufficient, and a new type of transformation has been found necessary. The essential idea of this transformation is to make the barrier correspond to a semicircle in a new Argand diagram. The general solution of the problem is then defined in terms of a Taylor expansion, and the choice of the coefficients in this expansion determines any particular curved barrier. Elegant formulæ exist for finding the pressure components on the barrier, and the line of action of the resultant pressure, but an explicit statement for the latter has not yet been published.

This process, due to Levi-Civita and others, can be made to yield numerical results of considerable interest. Brillouin has given the working for a set of barriers defined by a certain choice of the coefficients in the above-mentioned series. Further, by a process of approximation, circular and elliptic barriers admit of numerical solution.

Prof. Cisotti's résumé of the progress in this problem during the last fifteen years is masterly, and of great use to researchers in the subject. It seems, however, that the footnote on p. 179 is based on a misapprehension. Brillouin has given the conditions that must be satisfied if the free stream lines are to have finite curvature where they leave the barrier. The author urges that these conditions are not necessary. He is right, but Brillouin does not mean that these conditions

are to be satisfied always. As a matter of fact, the problems in which Brillouin's conditions are satisfied are those which have the greatest bearing on aerodynamical research. Further, Brillouin's conditions can be used to elucidate the rather puzzling question of the difference between barriers which are defined by the same mathematical curves, but of different extents, as *e.g.* circular barriers of different angular extents.

These two volumes can be highly recommended to all who are interested in recent developments in the mathematics of two-dimensional hydrodynamics.

S. BRODETSKY.

### Our Bookshelf.

*Register zum Zoologischen Anzeiger.* Begründet von J. Victor Carus. Herausgegeben von Prof. Eugen Korschelt. Band xxxvi.-xl., und *Bibliographia Zoologica*, vol. xviii.-xxii. Pp. iv+695. (Leipzig: Wilhelm Engelmann, 1922.) 280 marks.

ALL who have had occasion to use the bibliography which is issued with the "Zoologischer Anzeiger" know that much trouble and loss of time are involved in consulting the volumes not yet indexed in one of the five-yearly "Registers." They will welcome, therefore, this belated volume, which indexes, mainly, the papers published from 1909 to 1911, including also a few from 1912 and a good many of earlier date which had previously escaped notice. It is compiled according to the same plan as its predecessors. Each paper is indexed under its author's name, with an abbreviated title and a citation of the volume and page of the bibliography where the full reference will be found. There are also cross-references under systematic names where these are mentioned in the title, or in the brief notice appended to the entries in the bibliography, and all new generic names are separately entered.

It was the opinion of Herr Heinrich in Mr. H. G. Wells's story of "Mr. Britling" that "the English do not understand indexing." It may be only because of this national defect that we find the plan of the "Bibliographia Zoologica" cumbersome and inconvenient as compared with that of our own "Zoological Record." The volume before us is only an index to an index. It requires us to take down at least one other volume from the shelf before we can find the reference we want. It includes neither a subject index nor a geographical index, and the systematic references are far from adequate for the needs of the systematist. All bibliographies, however, are useful, if only because none of them is perfect, and certainly no zoologist can afford to neglect the "Bibliographia Zoologica." At the present time, when the obstacles to the international diffusion of knowledge are only slowly being removed, the need for such works and the difficulties in the way of compiling and publishing them are alike great. It is to be hoped, therefore, that this volume will soon be followed by others cataloguing the literature of more recent date.

W. T. C.

*Report of the Canadian Arctic Expedition, 1913-18.* Vol. xii.: *The Life of the Copper Eskimos.* By D. Jenness. (Southern Party, 1913-16.) Pp. 277. (Ottawa: Department of the Naval Service, 1922.) 50 cents.

THE report of the Canadian Arctic Expedition, 1913-18, is planned to include at least sixteen volumes. This, the ethnographical volume, is the work of Mr. D. Jenness, a graduate of the University of New Zealand, who received his anthropological training at Oxford, and is already known as the author of an important book entitled "The Northern D'Entrecasteaux." Mr. Jenness lived for some years in the tents and snow-houses of the Eskimo, and though he says little of his personal difficulties, the companionship of his Eskimo hosts and their strange food must have been a trying experience. With the help of a devoted missionary, the Rev. H. Girling, who unfortunately died of pneumonia at Ottawa in 1920, he has been able to prepare a singularly valuable account of life in all its phases among the Copper Eskimos, whose headquarters are on the Coppermine River. Fortunately for them, this land lies in the track of the Great Caribou migration when the herds move northward in the spring. They are then able to collect stores of meat and skins, and from this and the seals and fish, which are abundant, their wants are supplied. Formerly their hunting was done with bows and arrows, but these are now replaced by rifles, and it would be well for the Canadian Government to consider whether the use of improved weapons should not be controlled in the interests of game preservation.

The book is full of curious facts and is illustrated by photographs and maps. "With the influx of traders and missionaries into the country the conditions of life are fast changing. Famine looms less in the foreground, but in its place European diseases are threatening the health of the communities, and bid fair to rival all other causes in their effect on the death-rate." The suggestion that a period of quarantine and medical examination should be enforced on all strangers entering the Eskimo territory certainly deserves serious consideration.

*The Scope of School Geography.* By Dr. R. N. Rudmose Brown, O. J. R. Howarth, and J. Macfarlane. Pp. 158. (Oxford: Clarendon Press, 1922.) 5s. 6d. net.

THE authors have briefly reviewed the scope of school geography, maintaining two dominant themes throughout, one the essential unity of the subject, the other the scientific character of its data and its methods. "Geography, properly speaking, has a definite viewpoint of its own and is not a mosaic of loans from other subjects." "The teaching of geography is no less the work of a specialist than the teaching of chemistry or history."

The authors have adhered, and for school purposes perhaps correctly, to the statement that geography may be regarded as the interaction between man and his environment; but even for the purpose of this book it might have been desirable rather to have stated the broader and deeper truth that geography has as its field the distribution of the interrelations of many phenomena of which human activities form but one.

In the chapters dealing with meteorology, biology, oceanography, and economics the relations of these subjects to geography and the material which geography can and must derive from them for its own study is fully discussed. On the subject of maps and map-reading the book contains excellent advice. "The practical study of maps must entail the art of map-reading." "The map must be interpreted."

Many will disagree with the authors' application of the term historical geography. Some historical events depend for their complete interpretation on a knowledge of geography, but this is not historical geography; it is merely history fully understood. It is possible, however, in theory at least, to reconstruct for each region the geography of past epochs and to see for that area not merely the evolution of its history, but what is much more comprehensive, the evolution of its geography. This is historical geography.

The book should do much to remove the many anomalies which exist in the school study of the subject.

*Within the Atom: A Popular View of Electrons and Quanta.* By John Mills. Pp. xiii+215. (London: G. Routledge and Sons, Ltd., n.d.) 6s. net.

WHAT can a scientific reviewer say about books like this on "popular science"? Mr. Mills, who has quite a competent knowledge of his subject, sets out to initiate those who have no knowledge of physics and chemistry (and apparently no intention of acquiring it) into the mysteries of modern atomic theory. Of course the task is utterly impossible. Scientific theories serve mainly to explain facts, and those who have no knowledge of those facts can grasp little of their real meaning. Such satisfaction as they can obtain must be wholly different from that of the earnest student, who, even if he admits the morality of an attempt to delude the laity into the belief that they can appreciate scientific work without serious study, can never be in a position to judge whether an author has been successful in tickling the palates of his readers in the manner they desire.

However, from the sale of similar works we imagine that there are some who will appreciate the mixed fare set before them. Very mixed it is, ranging from a conversation (in the spirit, but not the style, of the celestial dialogues of Faust) between the author, an electron, energy and the reader to a more or less sober discussion of the difficulties of interpreting X-ray spectra. Indeed we find a certain inconsistency in our author's attitude; if he is prepared to make such a concession to sensationalism as to assert that the nucleus is smaller than the electrons which it contains, he need not have boggled over many quite minor difficulties which seem to us to occupy a disproportionate space. But then, as we said, we are clearly not in a position to judge.

*Süd-Bayern.* Von R. H. Francé. (Junk's Natur-Führer.) Pp. v+423. (Berlin: W. Junk, 1922.) M. 32 and 150 per cent "Valutazuschlag."

It is pleasant to think that the State of Bavaria was not dismembered by the great European peace, and we regret that Dr. Francé's scientific guide-book could not extend a little northward, so as to include the palæontological treasures of Eichstätt and the cauldron-

subsidence of the Ries. But the finest landscapes of the country await the traveller across the southern glacial plain. There is much, indeed, to detain him on the "Niederterrassenschotter" itself. Dr. Francé calls attention, for example, to the forest of Ebersberg, within easy reach for any botanist who visits Munich. Here the climatic change in modern Germany may be traced in the decay of the giant oaks in the eighteenth century, in the subsequent dwindling of the beeches, and in the present predominance of conifers, under which wild tulips grow. The site of Munich raises the puzzle of its apparent extinction in Roman times, though Roman roads run through it, based on predecessors built by Celtic engineers. The rapid rivers are themselves worth watching, as they stream from the Alps across the glacial deltas of the plainland. With this book as a companion, the naturalist will finally cross the old lake-floor to Partenkirchen, and will stand under the crags of the Wetterstein well content. G. A. J. C.

*In the Heart of Bantuland.* By Dugald Campbell. Pp. 313. (London: Seeley, Service and Co., Ltd., 1922.) 21s. net.

MR. CAMPBELL provides his readers with an abundance of good stories of big-game hunting, slave traders, and natives and Europeans whom he has met in his twenty-nine years of experience as a missionary. His travels range from the Katanga and Angola to the shores of Lake Nyassa. His use of the word "Bantuland," not merely in his title but in the text, may be misleading to the uninitiated, as he does not deal with all Bantu peoples, but only with those within the limits mentioned. Even thus he is not always sufficiently explicit in mentioning the tribe to which a particular custom or belief appertains. Many of the peoples with whom he deals are but little known, and his careful description of their culture is a useful addition to our knowledge. His account of secret societies of various types is worthy of note. Mr. Campbell gives to native character a tribute of admiration which is well deserved, as is shown by instances of self-sacrifice and bravery, while he has much to say of the political sagacity and instinct for government displayed by some of the tribes and their chiefs.

*The Technique of Psycho-Analysis.* By Dr. David Forsyth. Pp. viii+133. (London: Kegan Paul, Trench, Trübner and Co., Ltd., 1922.) 5s. net.

IN his book on the technique of psycho-analysis Dr. Forsyth deals, from the practical viewpoint, with a subject which is full of difficulties for the beginner in analytical work. The first chapter is devoted to a consideration of the analyst himself; the second deals with the conditions under which the treatment should proceed; the remaining four chapters discuss the actual analysis. Dream analysis is excluded as being too big a subject for discussion in such a book, and the reader is referred to Freud's "Interpretation of Dreams" for the study of this side of analytical treatment.

Dr. Forsyth gives much practical advice which is frequently omitted from literature on the theory and practice of psycho-analysis.

## Letters to the Editor.

[The Editor does not hold himself responsible for opinions expressed by his correspondents. Neither can he undertake to return, or to correspond with the writers of, rejected manuscripts intended for this or any other part of NATURE. No notice is taken of anonymous communications.]

### The Acoustics of Enclosed Spaces.

THE acoustics of enclosed spaces intended to hold large audiences is now receiving attention, and it is recognised that good conditions for distinct hearing can be obtained only by eliminating the reverberation due to reflection from the walls. Owing to the high velocity of the transmission of sound in nearly all solid bodies, the angle at which total reflection begins is small; for oak wood it is about  $6^\circ$ , and for glass as low as  $3^\circ$ . Unless the wave-front is therefore very nearly parallel to a wall it cannot penetrate and is sent back into the room. The simple and partially effective method of deadening the reverberation by covering the walls with a highly porous material, or woven stuffs, is difficult to apply in large spaces, and a more hopeful solution of the problem seems to me to lie in the discovery of a substance that can be used for the exterior lining of walls and has a velocity of transmission not far different from that in air.

Unfortunately our knowledge of the velocity of sound in different materials is very scanty. I am not aware that the acoustical properties of the substances most commonly used in buildings, such as stones, brick, and mortar or plaster of Paris, have ever been examined. My suggestion is to look for a suitable material which is transparent to sound and can be backed by highly porous matter which will absorb the transmitted vibration. If necessary, a series of alternate layers may be introduced. In referring to the tables of Landolt-Börnstein I find that the substance which has a velocity of transmission for sound nearest to that of air is cork. This might be taken as a starting point for further investigation, but there are great gaps and inconsistencies in the tables.

It is to be remarked that at nearly normal incidence, so long as no total reflection takes place, the posterior surface of the wall diminishes very considerably the intensity of the reflected sound. This is illustrated by the analogous problem in the theory of light. Applying the relevant equations (A. Schuster, "Optics," p. 71) to normal incidence we find for the reciprocal of the intensity of a wave transmitted through a wall:  $1 + \pi^2(1 - \mu^2)^2 e^2 / \lambda^2$ , where  $e$  is the thickness of the wall,  $\lambda$  the wave-length in air, and  $\mu$  the refractive index. It is here assumed that the thickness of the wall is small compared with the wave-length measured inside the wall, which will nearly always be the case. For wood the refractive index is about  $-1$ , and for stone it will probably be of the same order of magnitude. Applying the equations and assuming the wave-length to be 250 cm. in air, representing a frequency of 130, we find that a wall one metre thick would transmit 86 per cent. of the incident sound at normal incidence, and this would be increased to 98.5 per cent. if the thickness be reduced to 10 cm. Apart from absorption, it is to be expected that stone walls are fairly transparent to sound falling normally upon them. But, as has been said at the beginning, sound incident at angles slightly inclined to the normal is totally reflected.

Some interest attaches to the cognate problem of avoiding the transmission of sound from one room to another. I am not referring to the construction of sound-proof spaces of comparatively small dimen-

sions, such as telephone boxes, where the use of absorbing materials is permissible. But we are all familiar with rooms, more especially in hotels, where everything that is said in one room can be overheard next door. This is generally ascribed to the thinness of the walls. Apart from absorption, which is not likely to be very appreciable in a homogeneous material, no large diminution of the intensity of the transmitted sound should be expected from a moderate increase in the thickness of the walls. The above example shows what may be expected from theory. When we deal with bricks and mortar, or lath and plaster, the want of homogeneity may cause a considerable amount of scattering, and this would help in making the increased thickness more effective.

Unless my information as to our present knowledge is insufficient, it would appear that experimental investigation of the acoustical properties of materials, with regard to absorption, scattering, and the rate of transmission, are much needed at the present time. Such investigations may also have a theoretical interest, as they would include experiments on sheets, the thickness of which bears a much smaller ratio to the wave-length than we are accustomed to deal with in optics.

ARTHUR SCHUSTER.

### Some Spectrum Lines of Neutral Helium derived theoretically.

IT is well known that, owing to the prohibitive nature of the general problem of three (or more) bodies, Bohr's quantum theory has proved so far to be unable to account for any spectrum lines but those forming a series of the simple Balmerian type, *i.e.*

$$\nu = \kappa^2 N \left( \frac{1}{n^2} - \frac{1}{m^2} \right),$$

where  $N$  is the familiar Rydberg constant given by  $2\pi^2 m^4 c h^3$ , and  $\kappa$  the number of unit charges contained in the nucleus, or the atomic number. Apart from X-ray spectra of the higher atoms, for which  $\kappa$  is replaced empirically by a smaller and not necessarily a whole number (Moseley, Sommerfeld), and where the requirements of precision are not high, this simple type of formula covers, as a matter of fact, only the spectra of atomic hydrogen ( $\kappa = 1$ ) and of ionised helium ( $\kappa = 2$ ), which, having been deprived of one of its electrons, presents again the same problem of two bodies as the hydrogen atom. Accordingly, the known spectrum series of He<sup>+</sup>, the ultraviolet Lyman series, the principal or Fowler's series, and the Pickering series, are all of the simple Balmer type, with  $n = 2, 3, 4$  respectively.

The neutral helium atom, however, with its two electrons, emits an entirely different spectrum consisting in all of more than a hundred lines (Prof. Fowler's latest report contains, pp. 93-94, a list of 105 lines), some apparently "stray" lines, others arrayed empirically into series strongly deviating from the Balmer type, but all alike baffling modern theoretical spectroscopists. In fact, not a single one of these one hundred or so observed lines has, to my knowledge, been accounted for theoretically, the mere desire of attempting this being paralysed by the insuperable difficulty of the three-bodies problem. This is particularly so in the case of lithium ( $\kappa = 3$ ) and the higher atoms.

Now, it has occurred to me that, in the absence of a general solution (in finite form, of course), it may be worth while to try some special solution of that classical problem.

At first a sub-case of Lagrange's famous solution of 1772 suggested itself, namely, the collinear type of motions, in which the three bodies, in our case

the nucleus and the two electrons, are always collinear with each other, the latter describing two equal and oppositely situated ellipses around the former. But the corresponding spectrum formula, which is again

of the simple Balmer type, namely,  $\nu = 49N \left( \frac{1}{8} \left( \frac{1}{m^2} - \frac{1}{m'^2} \right) \right)$ ,

proved to be entirely useless, as (to judge from one's numerous trials extended up to  $n=8$ ) it does not cover, even within  $1.5\text{\AA}$ , a single observed line of He. This tends to show that such extremely special (collinear) states of motion, or at least passages between them, do not occur within the He-atoms, or if they do, then only so sporadically as to give no light of observable intensity.

What next suggested itself was the apparently trivial class of motions in which the mutual perturbation of the two electrons is negligible. Though approximately only, this class of solutions, being much broader than that of the collinear motions, would seem more likely to cover some actual spectrum lines. In fact, the very first trials gave encouraging results, as will be shown presently.

The energy of the system being for such states of motion equal to the sum of the energies due to the nucleus and each of the electrons taken separately, the corresponding spectrum formula for neutral helium is, obviously,

$$\nu = 4N \left( \frac{1}{n_1^2} + \frac{1}{n_2^2} - \frac{1}{m_1^2} - \frac{1}{m_2^2} \right),$$

or  $\nu = \nu_1 + \nu_2$ , where  $\nu_1$  and  $\nu_2$  are any two frequencies belonging to ionised helium, and thus represents a "combination principle" of a new kind. The resulting line of He, due to the passage of the two electrons from stationary orbits determined by  $m_1, m_2$  to a pair of orbits determined by  $n_1, n_2$ , may conveniently be denoted by  $\left( \begin{smallmatrix} m_1, m_2 \\ n_1, n_2 \end{smallmatrix} \right)$ .

This simple spectrum formula, the sum of two Balmerian ones, has yielded so far ten or eleven remarkably well-fitting lines, of which it will be enough to quote here a few.

Thus, to start with lines of the type  $\left( \begin{smallmatrix} m_1, m_2 \\ 4, 4 \end{smallmatrix} \right)$ , i.e. derivable from the Pickering series  $\left( \begin{smallmatrix} m \\ 4 \end{smallmatrix} \right)$  of  $\text{He}^+$ , we have the frequencies  $(\nu_1, \nu_2)$

$$\left( \begin{smallmatrix} 5 \\ 4 \end{smallmatrix} \right) \dots 9875.1,$$

$$\left( \begin{smallmatrix} 14 \\ 4 \end{smallmatrix} \right) \dots 25191.8,$$

the sum of which gives for the frequency of the theoretical line  $\left( \begin{smallmatrix} 5, 14 \\ 4, 4 \end{smallmatrix} \right)$   $\nu = 35067$ .

This agrees very closely with the nearest observed line at  $\lambda(\text{air}) 2851$  or  $\nu = 35065$ , which is tabulated among the combination lines of neutral helium (Fowler, p. 94). Similarly the members  $\left( \begin{smallmatrix} 5 \\ 4 \end{smallmatrix} \right)$  and  $\left( \begin{smallmatrix} 20 \\ 4 \end{smallmatrix} \right)$  of the Pickering series of  $\text{He}^+$  give  $\left( \begin{smallmatrix} 5, 20 \\ 4, 4 \end{smallmatrix} \right)$  with the frequency

$$\nu = 9875.1 + 26333.6 = 36209,$$

which is in striking coincidence with the observed He-line at  $\lambda = 2761$  or  $\nu = 36208$ .

In these examples both  $\nu_1$  and  $\nu_2$  are frequencies actually observed in  $\text{He}^+$ . But not less interesting are lines of the type  $\left( \begin{smallmatrix} m_1, m_2 \\ 4, 5 \end{smallmatrix} \right)$ , i.e. combinations of Pickering lines with those of a purely theoretical

$\text{He}^+$  series  $\nu = 4N \left( \frac{1}{5^2} - \frac{1}{m^2} \right)$ , and yet covering some observed lines of neutral helium very closely. Thus, we have (with  $N = 109723$ ):—

$$\left( \begin{smallmatrix} 6, 9 \\ 4, 5 \end{smallmatrix} \right), \nu = 27377, \lambda = 3651.8,$$

$$\left( \begin{smallmatrix} 6, 17 \\ 4, 5 \end{smallmatrix} \right), \nu = 31276, \lambda = 3196.4,$$

$$\left( \begin{smallmatrix} 6, 19 \\ 4, 5 \end{smallmatrix} \right), \nu = 31579, \lambda = 3165.7,$$

the nearest observed lines of neutral helium being  $\lambda 3652.0, 3196.7$ , and  $3166$  respectively.

Finally, an example in which both of the combined frequencies are purely theoretical is

$$\left( \begin{smallmatrix} 6, 28 \\ 5, 5 \end{smallmatrix} \right), \nu = 22360, \lambda = 4471.00,$$

with the nearest observed He-line at  $\lambda = 4471.48$ , tabulated (*loc. cit.*, p. 93) among the diffuse doublets.

Other examples of well-fitting lines and some further details are being given in a paper on this subject to appear in the September issue of the *Astrophysical Journal*.

Similarly one could try to cover some Li-lines by three pairs of terms, i.e. by  $\nu = 9N \left( \frac{1}{n_1^2} + \frac{1}{n_2^2} + \frac{1}{n_3^2} - \frac{1}{m_1^2} - \frac{1}{m_2^2} - \frac{1}{m_3^2} \right)$ , and some spectrum lines of the higher atoms by four and more pairs of terms. But since, with increasing number of independent terms, even a thorough agreement would appear more and more likely as the work of chance, it does not seem worth while to push the procedure much beyond lithium. For the latter element I have thus far found (with  $N = 109730$ ) eight well-fitting lines, of which the most interesting lines are  $\left( \begin{smallmatrix} 5, 14, 18 \\ 4, 13, 17 \end{smallmatrix} \right)$ ,  $\nu = 23394.4$  and  $\left( \begin{smallmatrix} 5, 12, 21 \\ 4, 10, 18 \end{smallmatrix} \right)$ ,  $\nu = 26046.6$ , which are remarkably close to the lithium lines observed at  $\nu = 23394.7$  and  $26046.9$ . But by far more interesting seem, for the present at least, the coincidences obtained for neutral helium. These would seem to justify the conclusion that there is a good deal of independence between its electrons.

LUDWIK SILBERSTEIN.

July 18.

In my letter of July 18 I considered the formula:

$$\nu = 4N \left[ \frac{1}{n_1^2} + \frac{1}{n_2^2} - \frac{1}{m_1^2} - \frac{1}{m_2^2} \right],$$

constructed as if the two electrons did not influence each other at all, and I mentioned that this spectrum formula had yielded ten or eleven well-fitting lines, of which six were actually quoted, the remaining lines being given in the full paper appearing in the *Astrophysical Journal*.

I now write to say that, to my own surprise, the same formula has since covered more than thirty further lines of neutral helium, and that when the whole ground is swept (by means of an auxiliary arithmetical table), almost the whole observed spectrum of helium is likely to be thus represented. While a complete list will be found in the paper referred to, some of these further lines may be quoted here so as to give an idea of the closeness of the agreement. Using the short symbol  $\left( \begin{smallmatrix} m_1, m_2 \\ n_1, n_2 \end{smallmatrix} \right)$  as already explained, we have, to five figures:—

Line.	$\nu_{calc.}$	$\nu_{obs.}$	Line.	$\nu_{calc.}$	$\nu_{obs.}$
(9.24 6.7)	14968	14970	(22.24 5.7)	24843.9	24843.96
(9.15 6.6)	17014.0	17014.3	(7.19 5.5)	24939	24935
(6.10 4.7)	19807	19805	(7.21 5.5)	25159	25157
(14.14 5.8)	19935	19932	(11.22 5.6)	25213	25215
(7.11 5.5)	22527	22529	(9.18 4.8)	25822	25820
(7.18 4.8)	23977	23980	(15.15 5.6)	25846	25849
(10.20 5.6)	24261	24260	(13.20 5.6)	26053	26047

The  $\nu$ -region beyond 26047 has thus far not been swept systematically. When this is done, I have but little doubt that ninety or more of the one hundred and five lines of helium will be accounted for. In these circumstances one would feel justified in asserting that the absence of mutual repulsion between the electrons is not (as I first thought) an exception but rather the rule. A simple estimate will show that if the usual Coulomb repulsion law were valid in any of the considered stationary states, the mutual energy of the electrons would contribute several thousand units to  $\nu$ . Since it is hard to explain away so many coincidences as due to chance, we are driven to the belief that the electrons within the atom do not repel each other even with a small fraction of the force usually attributed to them. In other words, the field of force of a bound electron seems to be entirely engaged by the nucleus, at least in the case of helium and probably of lithium, but possibly also in that of the higher atoms.

LUDWIK SILBERSTEIN.

129 Seneca Parkway, Rochester, New York,

July 26.

### The Primitive Crust of the Earth.

IN reference to the letter of Dr. Harold Jeffreys (NATURE, July 29, 1922), I wish at once to say that nothing in my letter published on July 8 was intended to express my adhesion or non-adhesion to those who support the planetesimal hypothesis. Even if we think that the earth originated in a rain and concentration of solid planetesimals, we may, with Prof. R. A. Daly, regard its complete fusion at a later stage as a very probable event. At some time or other, the earth may well have possessed a crust consolidated from "igneous" fusion. Prof. J. Joly now suggests to us, with his unflinching brilliance of outlook, the recurrence of such a crust after successive meltings of the globe. What I have urged, however, is that the oldest rocks traceable by geologists must not be regarded as a record of a primitive crust. They are sediments, invaded again and again by igneous matter from below. We cannot conclude from our Archaean schists, which are so often converted into composite gneiss, that there was ever a crust formed of crystalline rocks about the globe. The "extent of the crust accessible to geologists" is, of course, much more than the film 2.5 km. thick stated by Dr. Harold Jeffreys. Owing to the great movements that bring up antique masses from the depths, rocks that consolidated finally under several miles of sediments now form a large part of the surface. But so far no planetesimal sediment has come to light, although matter of the mineral composition demanded by the hypothesis is associated with many igneous upwellings.

In support of the concluding remarks of Dr. Harold Jeffreys, attention may be directed to "A Critical Review of Chamberlin's Groundwork for the Study of Megadiastrophism," by W. F. Jones, published in the *American Journal of Science* for June of the present year.

GRENVILLE A. J. COLE.

Carrickmines, Co. Dublin, July 29, 1922.

### Peculiarities of the Electric Discharge in Oxygen.

SEVERAL years ago I described (*Phil. Mag.*, April 1908) a discontinuity in the electric discharge in oxygen at pressures near to 0.8 mm. Namely, when a current (0.0025 amp.) was passed in a discharge tube (diam. 2.4 cm.), the electric force in the positive column suddenly changed on slightly lowering the pressure from about 11 volts per cm. to about 20, an effect which could be reversed by raising the pressure.

Some experiments which I have made recently, with the assistance of Mr. E. P. Cardew, have shown that at pressures in the same neighbourhood, with a fixed circuit (battery and resistance), the discharge is not uniquely determined, but can be one or the other of two distinct types, distinguished by a remarkable difference in the values of the electric force within the positive column, one of these values being about twice the other. The magnitude of the current with the higher electric force in its positive column is less than the other, since the potential difference of the electrodes is greater in its case; but the currents tend to equality when the electrodes are so near that the positive column tends to disappear. The two discharges differ only slightly in appearance: the positive column of the smaller one with the higher electric force being somewhat shorter and a trifle paler than the other—both being without striæ in general.

To give an example. With a battery of 990 volts and external resistance 363,000 ohms, electrodes 21.8 cm. apart in a tube of 27 mm. diameter, and pressure 0.75 mm., the currents observed were 1.19 and 0.883 milliamperes; their positive columns were nearly 15 and 14 cm. long, and the electric force within them about 9 and 18.5 volts per cm. respectively. In this and in many other cases, by means of a certain arrangement, the discharge could be made to change from one form to the other without stopping the current or altering the circuit.

The region of pressures within which alternative currents have been so far observed are from 0.64 to 0.91 mm. The two types of discharge differ in stability according to the pressure and the magnitude of the currents, so that the discharge tends to assume one type rather than the other. But the one having the high electric force in the positive column is much more definite and invariable than the other for a given pressure, being in this respect similar to discharges in other gases, so that that electric force can be determined with much more precision, and is in fact nearly the same as in hydrogen.

Since these effects hold good for a large range of current, it is obviously possible, by adjusting the external circuit, to make two discharges of the same arbitrary magnitude (of the necessary order) pass through oxygen, between electrodes at a given distance apart, at any given pressure within the range in question, one of which will have the high electric force in its positive column and the other the low.

P. J. KIRKBY.

Salham Toney Rectory, Watton, Norfolk,

July 26.

### Defoliation of Oaks.

A REFERENCE to the defoliation of oaks, particularly on the borders of Surrey and Hampshire, by the larva of *Tortrix viridana*, was made in NATURE on June 10. It concludes with the remark that the effect of the defoliation is to check "the growth of the trees to some extent for the time being, but is rarely more serious."

At Haslemere, in the south-west corner of Surrey, infestation by the *Tortrix* larva was sufficiently marked fifteen years ago to be the subject of comment, and it has continued ever since. In some years the attacks were very severe. For a long time infested trees did not appear to suffer any serious harm. In recent years, however, the American White Mildew, *Oidium alphitoides*—which in the early years of its appearance in this country infested the leaves of pollard and sapling oaks only—has invaded the new leaves which the trees put forth after defoliation by the caterpillars. The effect of the combined attack is already becoming very serious. In the tract of country lying between the towns of Haslemere, Petersfield, Midhurst, Petworth, Horsham, and Godalming, many oaks have been killed outright, and large numbers are slowly dying. It seems very desirable that these dead and dying trees be removed and destroyed, or they may become centres for the spread of beetles destructive to timber.

E. W. SWANTON.

Educational Museum, Haslemere,  
August 1.

### Scorpions and their Venom.

PHYSALIA in "Animaux Venimeux," p. 252, says that in all venomous animals their immunity to their own venom is limited, and announces that in an experiment a scorpion, *Buthus australis*, was killed by an injection of the same venom as its own. I should like to add further observations from personal experience, bearing on this very interesting subject.

Until very recently, by many, and even now by some, the accepted opinion of men of science was that each venomous animal carried its own antidote, *i.e.* was immune to the effects of its own venom.

So long ago as 1900, when for some weeks during the Boer War I was stationed with my company in the Blue River mountains opposite the Metrosberg Peak in Cape Colony, I witnessed numerous fights between the different species of scorpions. In more than a hundred fights between two scorpions, each of the same species, whether black, red or yellow, the result was always the same, the one that was stung by its opponent dying almost immediately, 10 seconds being the longest interval between receiving the sting and death.

The result when *different* species were pitted against each other was the same, but that was to be expected.

C. E. F. MOUAT-BIGGS.

Hampden Club, Hampden Street, N.W.1,  
July 7, 1922.

### Bloomsbury.

It is to be regretted that in his interesting article on Bloomsbury and the University of London, Mr. Humberstone repeats the erroneous statement that Bloomsbury was originally Lomsbury. That statement was made by John Stow, London's first historian, but one can only suppose that he was misled by the mistake of some early copyist. The earliest form of the name known to me is Blemidesberie. I am writing away from references, but that form is at

least as old as the fourteenth century. Like other place-names ending in *-sbury* it must be derived from the personal name of its owner, possibly Blemund.

The further statement that the Royal Mews, at Bloomsbury, were burnt down in 1537, is also not quite accurate. The royal stables were burnt then, but the Mews (*i.e.* falconry) were situated at Charing Cross, on the site of the present Trafalgar Square, at least as early as 1443 (the earliest reference verifiable at the moment). It was the transference of the royal stables to Charing Cross that led to the change in the meaning of the word "mews" to that which it still bears.

A. MORLEY DAVIES.

Amersham, July 29.

I REGRET that my article should have contained the errors to which Dr. Morley Davies draws attention. Stow wrote: "But in the year of Christ 1534. the 26. of H. the 8. the king hauing faire stabling at Lomsbery (a Manor in the farthest west part of Oldborne) the same was fiered and burnt, with many great horses, and great store of Hay. After which time, the forenamed house called the Mewse by Charing Cross was new builded, and prepared for the stabling of the kings horses. . . ." H. B. Wheatley in "London Past and Present" states that Bloomsbury is a corruption of Blemundsbery, the manor of the De Blemontes, Blemunds, or Blemmots. Blemund's Dyche, which was afterwards Bloomsbury Great Ditch, and Southampton Sewer divided the two manors of St. Giles and Bloomsbury. He adds: "There is an absurd statement, taken from Stow's Survey, that the name of Bloomsbury was originally Lomsbery. This could only have occurred by a misprint, in which the B was inadvertently dropped."

T. LL. HUMBERSTONE.

### Absorption of Potassium Vapour in the Associated Series.

IN our investigations on the optical properties of potassium vapour we found that there were some traces of absorption in the above series at about 1100° C., the results of which were embodied in a note to appear shortly in the *Phil. Mag.* As a result of further experiments conducted in the Physical Laboratory of this college, we now feel fairly sure that we have detected distinct traces of absorption in the diffuse series; the bands 5780, 5340, 5300, and 5100 surely correspond to 5782, 5340, 5323, and 5100 of (*2p-m.d.*).

The well-defined dark line 4640 previously observed by us at about 900° C. is confirmed to be the combination line (*1s-2d*) recently observed by Datta in the vacuum arc spectrum of potassium (*Proc. Roy. Soc.*, 99, April 1921) and by J. K. Robertson on "Electrodeless Discharge in certain Vapours" (*Physical Review*, May 1922).

At these high temperatures the chemical difficulties are so great, and the conditions in the experimental tube so unstable, that, in spite of many attempts, we found it difficult to obtain a good negative, on account of the tube giving way owing to the chemical action of potassium vapour on its walls. Further experiments are in progress, and we hope to confirm these observations by photography, as these experiments lend weight to Saha's theory of temperature radiation.

A. L. NARAYANA.

D. GUNNAYIA.

Maharajah's College, Vizianagram, July 10.



### A Recording and Integrating Gas Calorimeter.

By Dr. J. S. G. THOMAS, Senior Physicist, South Metropolitan Gas Company.

**U**NDERTAKINGS operating under the provisions of the Gas Regulation Act 1920, are required to deliver gas of a declared calorific value to consumers, and charges to individual consumers are to be based upon the value of the total thermal energy supplied to each. By calorific value is to be understood the number of B.Th.U. produced by the combustion of 1 cubic foot of gas measured at 60° F. under a pressure of 30 inches of mercury and saturated with water vapour. Under the Act, penalties are to be inflicted upon the gas undertaking, if on any day for a period of two hours or more the calorific value of the gas supplied is more than 6 per cent. below the declared calorific value, or if in any quarter the average calorific value is less than the declared calorific value. Embodied in Orders under the Act are clauses governing the price per therm (100,000 B.Th.U.) to be charged by individual gas undertakings, and the amount of dividend to be paid to proprietors, as regulated by this price. Such, in brief, are the main thermal clauses of the Gas Regulation Act 1920—the Charter of Liberty of the gas industry in this country, and the consumers' guarantee that gas undertakings must and will "deliver the goods."

Accurate gas calorimetry has long been of importance for scientific purposes; extremely accurate gas calorimetry is now of consequence industrially and socially. The accuracy of determination desirable will be realised when it is understood that, in terms of money, an error of 1 per cent. in respect of the thermal value of the annual gas supply of England, Scotland, and Wales represents about 500,000*l.*

Prof. C. V. Boys, at the annual meeting of the Institution of Gas Engineers on June 22, exhibited and described a recording and integrating calorimeter (Fig. 1) which he has designed and constructed primarily to meet the requirements of the Act in the matter of continuously recording the calorific value of towns' gas. The instrument is, however, immediately applicable to the determination and recording of the calorific value and percentage variation of the calorific value with time of the calorific value of any gas. It is of the water-flow type, the same water being circulated continuously through the apparatus and cooled to atmospheric temperature, by the hot-air engine and cooling coil seen at the bottom left-hand side of the figure. This is an important consideration in continuous calorimetry, as with another form of recording gas calorimeter at present available the cost of water amounts to about 20*l.* per annum. The fundamental features of the instrument are: water and gas are doled out positively at the correct respective rates, and the

correction for gas volume as affected by temperature, pressure, and humidity are likewise effected by a positive operation.

*Water Measurement and General.*—Water flows from a tank, seen in the top right-hand corner of Fig. 1, where the level is maintained constant, through a

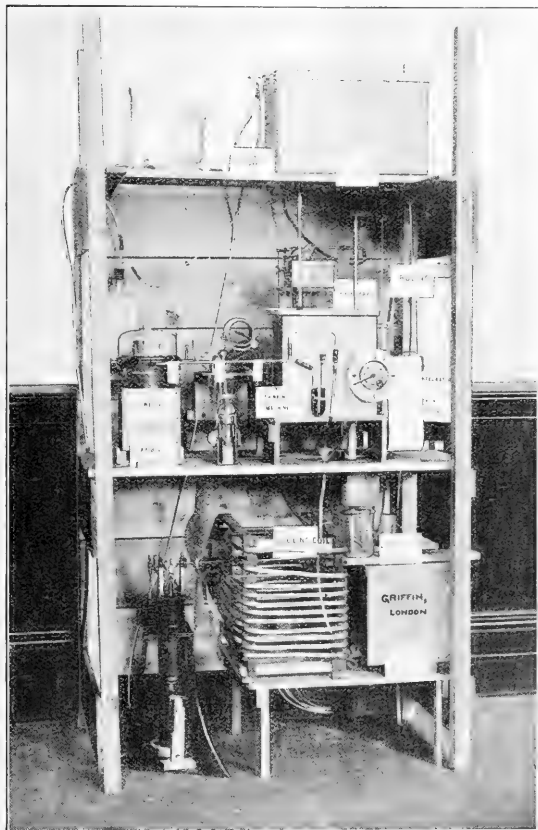

FIG. 1.

nozzle into a celluloid bucket pivoted eccentrically and so proportioned that it overbalances and empties into the celluloid water-box shown in Fig. 1. After emptying and draining, the bucket is released by a clock every half-minute, and the operation is repeated. The quantity of water delivered to the bucket can be adjusted by a stop, so that if the gas is of the declared calorific value, the rise of temperature of the water flowing in the calorimeter is exactly 10° C. On the record sheet, therefore, corresponding percentage

departures from the declared calorific value are strictly comparable, being represented by equal displacements of the recording point, whatever the declared calorific value.

The water doled out passes through a small hole into a second compartment of the water-box, and thence to the calorimeter proper. When the bucket is overturned, the jet of water misses the bucket and enters a third compartment of the water-box, whence it passes to a fourth compartment, to be delivered to a small celluloid water-wheel, which drives, through an elastic connection, the escapement of a one-wheel pendulum clock ticking half-seconds, and through an intervening mechanism—called by Prof. Boys the "thinking machine"—the axle of the gas meter.

*The Gas Meter.*—The gas meter is shown in vertical section in Fig. 2, the smallest arrow indicating the direction of entry of gas previously saturated with water vapour. The meter drum is of celluloid, and is provided with buoyancy chambers A, so that the drum is largely carried by the water and not by the axle. The gas measured in any compartment is therefore contained

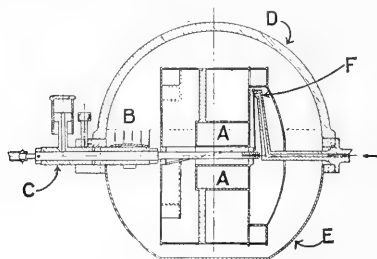

FIG. 2.

in a chamber of which the sides, ends, roof, and about two-thirds of the floor are independent of the water-level, which can be adjusted to  $\frac{1}{100000}$ th inch by reference to the upturned points, B. Changes of water-level, even if they should occur, would clearly have little effect on the capacity of the meter. The meter drum rests loosely on the axle, which is screwed, so that if meter and axle turn at the same rate there is no endlong movement of the drum. The axle works in a long sleeve, C, screwed into a brass ring, and vaseline is forced in to make axle and sleeve water-tight. No stuffing boxes are employed, and the inlet and outlet aprons of the usual wet-meter drum are replaced by discs closing the front and back of the usual four compartments. The meter is enclosed gas-tight within a glass bell D above, and a spun copper bowl E, below. The pressure in the meter is about  $\frac{1}{8}$  inch of water in excess of atmospheric, such excess being due to the inclusion in the gas circuit of a pin-hole burner to prevent the calorimeter burner being extinguished by the sudden slamming to of a door, etc.

*The "Thinking Machine."*—This device, already referred to, is shown in plan in Fig. 3A. It consists of a small ball-disc-cylinder integrator, a vertical section of which is shown in Fig. 3B, coupled with epicyclic double reduction gear, as shown at A in Fig. 3A, inserted between the clock and the meter axle so as to control the rate of revolution of the meter drum.

The epicyclic device gears down the motion of the disc of the integrator in the ratio 3 : 2, the disc itself being geared down from the water-wheel in the ratio 4 : 1. The motion of the cylinder of the integrator is geared down in the ratio 15 : 1.

Temperature and pressure corrections to the gas volume are automatically and positively effected in the following way. It is clear that if the ball, B (Fig. 3B), makes contact with the rotating disc, C,

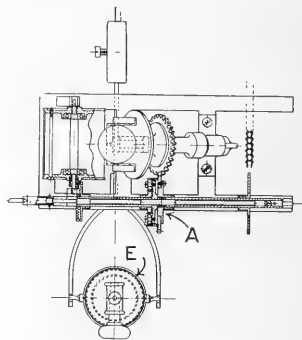

FIG. 3A.

exactly at the centre of the disc, no rotary motion will be communicated by the disc to the ball and consequently none to the cylinder D. Such a position of the ball corresponds to normal conditions of temperature (60° F.) and pressure (30 ins. of mercury) of the gas, and may be conveniently referred to as its N.T.P. position. The radial displacement of the ball from the centre of the disc is made to depend upon atmospheric temperature and pressure as follows: E (Fig. 3A) shows in plan a glass bell filled with air floating

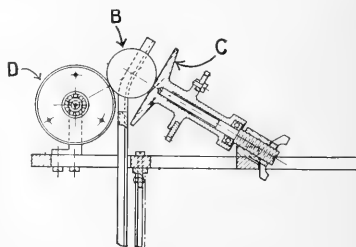

FIG. 3B.

in a mercury and water seal, and connected by a lever system with a fork which displaces the ball to one side or other of the centre of the disc, according as the bell rises or falls with change of atmospheric conditions. The lever system is such that the ball moves 1 inch, equal to the radius of the cylinder, when the gas volume correction is 10 per cent. Such displacement of the ball is accompanied by its rotation, producing rotation of the cylinder, D, whereby endlong motion is communicated to the meter drum, resulting in the gas inlet to the meter, F, Fig. 2, being further closed or opened as required, so that the rate of gas delivery

reduced to standard conditions is maintained constant to within  $\frac{1}{10}$  per cent. The corrections effected over a period of a month are automatically recorded on a drum revolving above the device. The method of mounting the meter drum loose on a screwed axle also prevents the occurrence of accidents should the gas supply be temporarily cut off and resumed later, or should the water flow cease. The possible interference of a mouse with the righting of the bucket after emptying is also ingeniously provided for.

*The Calorimeter Proper.*—This is shown in vertical section in Fig. 4. A and B are the hot and cold water chambers respectively; C is the heat interchanger, in which the heat of the products of combustion derived from gas burning at the fused-silica burner, D, is communicated to the stream of water. A silica dome is disposed above the flame. The interchanger is made of sheet-lead closely folded into fifteen zig-zags round the central combustion space. Narrow up-cast water-ways are then formed on one side of the sheet, and down-cast gas-ways on the other side. The heated water passes to B through the narrow neck in the double partition, E, a device introduced by Prof. Boys to prevent the calorimeter indicating more heat than is produced by the gas. The copper cylinder, F, fixed to the brass ring, G, is so proportioned, that loss of heat from the upper part of the hot-water compartment is compensated by the equal gain from the cylinder lower down by the heat interchanger.

The operative thermometers, H and J, are of brass, and are filled with amyl alcohol. They are closed with corrugated brass covers. A lever system utilising the third dimension of space, magnifies the deformation of the respective covers occurring with change of temperature, and the net difference of temperature of the two thermometers, due to heating, controls the position of an inked pen recording on a roll of paper, seen on the right of Fig. 1, kept in motion by

the clock. On the paper parallel lines are ruled during the rotation, indicating definite percentage departures of the actual measured calorific value of the gas from the declared calorific value. Time indications are in like manner impressed upon the record. An integrating device shown on the right of Fig. 4, operating after the manner of the Amsler planimeter and controlled by the position of the recording pen, averages the departures of the calorific value of the gas from the declared calorific value since

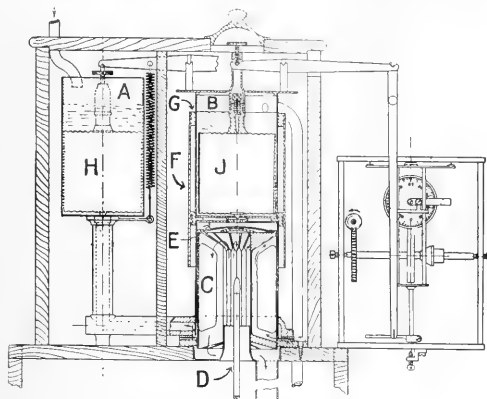

FIG. 4.

the indicator was last set to zero, *i.e.*, since the beginning of the quarter, so that, for example, the integrator indicating +5 would signify a 5-day 1 per cent. excess of calorific value, or a 1-day 5 per cent. excess, etc.

The writer is extremely obliged to Prof. Boys for the kind manner in which he has afforded information concerning the instrument, and to Messrs. Griffin and Sons for providing the illustrations reproduced in this article.

## The Earth's "Crust" and its Composition.

By THOMAS CROOK.

THE term "crust" is frequently used in dealing with the constitution of the earth, but is seldom defined. It is a convenient scientific term to apply to the earth's outermost shell, the only portion of which geologists have much positive knowledge, and if it is put to scientific use, it should be defined, although a definition of it may involve some hypothesis as to the physical condition of the earth's interior.

According to Arrhenius, who assumes that the temperature-gradient observed in continental areas is persistent in depth, the temperature of the earth's interior greatly exceeds that of the critical temperature of the materials occurring there. He infers therefore that the interior is for the most part gaseous though rigid, and that this gaseous core is separated by a molten layer from an outer solid shell about 40 miles thick.

Osmond Fisher assumed a molten condition at a depth of 25 miles. To those who accept this view, the term "crust" has a very real and simple significance: it is the thin, solid, outer shell of the earth, underlain by molten magma.

At the present time, however, this hypothesis appears not to be widely held among geophysicists, most of whom follow Lord Kelvin, Sir George Darwin, and other eminent authorities who have shown good reasons for rejecting the hypothesis of a molten interior at such depths as postulated by Fisher and Arrhenius, and who claim that the earth is solid throughout. For those who adopt this view the definition of the earth's "crust" is a more difficult matter.

The prevalent view at the present day as regards the constitution of the earth's interior is that it consists of an inner core of nickel-iron about 6200 miles in

diameter, surrounding which is a silicate shell some 900 miles in thickness. The silicate shell is largely ultra-basic and basic. Lying on the thick shell of basaltic rock, which girdles the whole earth, is a comparatively thin and discontinuous layer of more siliceous rock-matter (granite and gneiss), on which the sedimentary rocks have been formed in and around the continental areas. According to the conception of a solid earth so constituted, we clearly have no satisfactory basis for defining the earth's "crust" in terms of the kind of rock of which it is made up, and unless it can be shown that, at some convenient and fairly uniform depth, the rock-substance of the earth undergoes a critical change in its physical condition at the temperature and pressure prevailing there, the only available alternative is to define the "crust" in a more arbitrary manner in terms of depth.

One way of doing this is to limit its thickness, as some authors do, to that outer portion of the earth of which we may be said to have observational knowledge. The maximum depth at which rocks observable at the surface of the earth have been formed is quite an important geological problem from the economic as well as from the scientific viewpoint, and one that appears never to have been treated adequately. It may, however, perhaps safely be inferred that, by observation of surface geological features, we have a knowledge of the earth down to a depth of more than 5 miles, but considerably less than 10 miles.

In their most recent estimate of the average composition of the earth's "crust," Drs. F. W. Clarke and H. S. Washington, of the United States Geological Survey, give its average composition down to depths of 10 and 20 miles. The detailed statement of their results has not yet been published, but is to be issued as a Professional Paper by the U.S. Geological Survey. Pending the publication of the detailed report, however, they have given a brief account of their results in the Proceedings of the National Academy of Science (1922, vol. 8, p. 108).

The method adopted by them for ascertaining the average composition of the lithosphere is to take the average of trustworthy analyses of igneous rock specimens collected from various parts of the earth's surface. They have included 5159 analyses. Averages are given separately for the igneous rocks of the United States; North America other than the United States, including Greenland; Central and South America; Europe; Africa and Asia; Australasia, Polynesia and Antarctica. In computing the averages for these various regions the sum total of each constituent was divided by the total number of analyses of specimens from the region dealt with. In calculating the composition of the earth's "crust" as a whole, the proportions of the lithosphere, hydrosphere and atmosphere for a depth of ten miles were taken as follows:—lithosphere 93 per cent., hydrosphere 7 per cent., and atmosphere 0.03 per cent. The lithosphere is assumed to be made up as follows:—igneous rocks, 95 per cent.; shale, 4 per cent.; sandstone, 0.75 per cent.; and limestone, 0.25 per cent. Figures are given for the rarer as well as for the commoner elements.

The following is the result obtained for the average chemical composition of the igneous rocks of the earth:—

## AVERAGE IGNEOUS ROCK.

SiO <sub>2</sub>	Per cent.	F	Per cent.
Al <sub>2</sub> O <sub>3</sub>	59.12	S	0.030
Fe <sub>2</sub> O <sub>3</sub>	15.34	(Ce, Y) <sub>2</sub> O <sub>3</sub>	0.052
FeO	3.08	Cr <sub>2</sub> O <sub>3</sub>	0.020
MgO	3.80	V <sub>2</sub> O <sub>5</sub>	0.055
CaO	3.49	MnO	0.026
Na <sub>2</sub> O	5.08	NiO	0.124
K <sub>2</sub> O	3.84	BaO	0.025
H <sub>2</sub> O+	3.13	StrO	0.35
CO <sub>2</sub>	1.15	Li <sub>2</sub> O	0.02
TiO <sub>2</sub>	0.101	Cu	0.008
ZrO <sub>2</sub>	1.050	Zn	0.010
P <sub>2</sub> O <sub>5</sub>	0.039	Pb	0.004
Cl	0.299		0.002
	0.048		

100.000

The following table shows the estimated percentages of the commoner elements in the lithosphere, hydrosphere and atmosphere:—

## ELEMENTS IN THE LITHOSPHERE, HYDROSPHERE, AND ATMOSPHERE.

	1	2	3	4
Oxygen . . .	49.19	47.80	46.68	46.41
Silicon . . .	25.71	26.65	27.60	27.58
Aluminium . . .	7.50	7.79	8.05	8.08
Iron . . .	4.68	4.88	5.03	5.08
Calcium . . .	3.37	3.49	3.63	3.61
Sodium . . .	2.61	2.72	2.76	2.83
Potassium . . .	2.38	2.48	2.56	2.58
Magnesium . . .	1.94	2.01	2.07	2.09
Hydrogen . . .	0.872	0.97	0.145	0.129
Titanium . . .	0.648	0.684	0.696	0.720
Chlorine . . .	0.228	0.162	0.095	0.096
Phosphorus . . .	0.142	0.150	0.152	0.157
Carbon . . .	0.139	0.095	0.149	0.051
Manganese . . .	0.108	0.116	0.116	0.124
Sulphur . . .	0.093	0.086	0.100	0.080
Barium . . .	0.075	0.078	0.079	0.081
Chromium . . .	0.062	0.065	0.066	0.068
Zirconium . . .	0.048	0.050	0.052	0.052
Vanadium . . .	0.038	0.040	0.041	0.041
Strontium . . .	0.032	0.034	0.034	0.034
Fluorine . . .	0.030	0.030	0.030	0.030
Nickel . . .	0.030	0.031	0.031	0.031
Nitrogen . . .	0.030	0.016	..	..
Cerium, Yttrium	0.019	0.020	0.020	0.020
Copper . . .	0.010	0.010	0.010	0.010
Lithium . . .	0.005	0.005	0.005	0.005
Zinc . . .	0.004	0.004	0.004	0.004
Cobalt . . .	0.003	0.003	0.003	0.003
Lead . . .	0.002	0.002	0.002	0.002
Boron . . .	0.001	0.001	0.001	0.001
Glucium . . .	0.001	0.001	0.001	0.001

100.000 100.000 100.000 100.000

1. Average composition. Ten-mile crust, hydrosphere, and atmosphere.
2. Average composition. Twenty-mile crust, hydrosphere, and atmosphere.
3. Average composition. Ten-mile crust, igneous and sedimentary rocks.
4. Average composition. Ten-mile crust. Igneous rocks.

A serious defect in the method of procedure on which the above estimates by Clarke and Washington are based is that it makes no allowance for the relative magnitude of the different kinds of rock of which the lithosphere is composed. They admit this defect, but claim that any errors involved are likely to be compensating (*Journ. Franklin Inst.*, 1920, vol. 190, p. 770). Their claim can scarcely be allowed, however, even for the outer 10 miles of the "crust," and still less can it be allowed down to a depth of 20 miles.

As to the relative proportions of the rocks composing

the lithosphere at this depth, even at 10 miles, we have as yet no positive knowledge, but the distribution of igneous rocks at the surface of the earth, and a comparison of oceanic and continental regions, give us some important facts to guide our reasoning on this matter. We are probably not far from the truth if we assume that the granitic portion of the lithosphere is largely restricted to the continental regions of the earth, and its thickness may not exceed an average of about 5 miles. If so, assuming this granite layer in continental regions to contain on an average 70 per cent. of silica, and assuming that it is underlain to a depth of 10 miles from the surface by basalt containing on an average 48 per cent. of silica, this would give us a silica percentage of about 59 for the average igneous rock of the lithosphere in continental regions down to a depth of 10 miles, which is in agreement with the average of the igneous rock of the "crust" as estimated by Clarke and Washington.

It should be noted that this takes no account of the "crust" of the oceanic regions, which is probably in large part basaltic. We may for the purpose of this argument assume that the granite shell of continental regions covers half the earth. This is an extravagant assumption, but as it doubtless errs substantially in exaggerating the acidity of the "crust," the error is on the right side so far as the present argument is concerned. If we further assume the sub-oceanic "crust" down to a depth of 10 miles to be basaltic, and to contain on an average 48 per cent. of silica, this would give us an average igneous rock containing about 53½ per cent. of silica for the outer 10 miles of the lithosphere all round the earth.

Extending our considerations to a depth of 20 miles, there can be little doubt that we should regard the

deeper 10 miles as on the whole more basic than the basaltic material of the outer 10 miles, and it is reasonable to assume that this deeper layer of basalt does not contain on the average more than 46 per cent. of silica. If we make this assumption, then the average rock of the earth's "crust" as a whole down to a depth of 20 miles would contain not more than about 50 per cent. of silica.

Comparing these with the figures given above by Clarke and Washington, the inference we draw is that they have probably much understated the basicity of the earth's "crust." Their average down to a depth of 10 miles is, as we have seen, only acceptable for continental regions, and cannot be admitted for the earth as a whole. Still less can their average for the lithosphere down to a depth of 20 miles be admitted, for, as we have seen, there is good reason for believing that the average rock down to this depth probably corresponds to a gabbro, containing about 50 per cent. of silica, rather than, as they infer, to a granodiorite containing 59 per cent. of silica.

This question of the average composition of the earth's "crust" has important bearings on many scientific and economic problems. It is quite commonly assumed that the average igneous rock is intermediate in composition, and that granitic and basaltic eruptives are products of differentiation derived from intermediate magmas. It seems highly probable, however, that the average igneous rock of the earth's crust is basic; and although differentiation does undoubtedly play an important part in the formation of igneous rocks, the claim that granites and basalts are in general differentiates from magmas of intermediate composition has no adequate foundation in the facts known to us concerning the petrology of the earth.

### Centenary of the Death of William Herschel.

ON August 25, 1822—a hundred years ago—William Herschel died at Slough, aged eighty-three years and nine months. His scientific activity had continued almost to the end of his long life. His last published paper was read before the Royal Astronomical Society (of which he was the first President) in June 1821. It is the only one of his seventy memoirs which was not published in the *Philosophical Transactions*, of the yearly volumes of which for the years 1780 to 1818 inclusive only those for 1813 and 1816 contain nothing by him, while not a few volumes include several papers from his hand. Even in the last year of his life, when his son, under his continual guidance, made and figured the 18¾-inch mirror, which was afterwards used by Sir John Herschel at Slough and at the Cape, it is recorded that "the interest he took in this work and the clearness and precision of his directions showed a mind unbroken by age and still capable of turning all the resources of former experience to the best account."

When Herschel, on March 1, 1774, began to keep a record of what he saw in the heavens with telescopes made by himself, it was natural that he should for some years show no decided preference for any particular branch of astronomy. At first he paid some attention to the planets, and determined the rotation-periods of Jupiter and Mars. But it did not escape his clear

perception very long that what was urgently required at that time was a systematic study of the vast number of celestial bodies outside the solar system. If Herschel had not early grasped this fact, and persevered all the rest of his life in his devotion to sidereal astronomy, he would never have become a great astronomer, but would merely, like his contemporary, Schröter, have been known as an indefatigable observer who occasionally did some good work. But on his way from the solar system out into space beyond it Herschel found a new planet (Uranus), about twice as far from the sun as what had up to then been considered the outermost planet. This was not a lucky accident, but a discovery which was bound to be made sooner or later by an observer who searched the heavens as systematically as he did. It was the first time since the prehistoric ages that a new planet was discovered. Herschel afterwards found two satellites of Uranus and two of Saturn, but his principal work was always on subjects connected with sidereal astronomy.

"A knowledge of the construction of the heavens has always been the ultimate object of my observations." This was the opening sentence of his paper of 1811, and as he had said much the same in the concluding words of his first paper (of 1784) on that subject, we see how faithful he remained to the plan of work he had adopted early in his scientific career.

Speculations on the construction of the universe had been made before Herschel's time: by Thomas Wright in 1750, by an anonymous writer in 1755 (who afterwards turned out to be Immanuel Kant, and adopted most of Wright's conclusions), by Lambert, and by Michell. None of these writers had made any observations on which to found their theories. But Herschel would build on observed facts so far as possible. He began by attempting to find the distance of the fixed stars by measuring double stars. This turned out to be impossible; but the work done was not wasted, as hundreds of double stars had been found and measured. When many of these measures were repeated some twenty years later, the great discovery was made that not a few of these pairs of stars were revolving round their common centre of gravity. The nebulae and clusters of stars were next systematically searched for; 2500 were found and their places determined. Herschel started with the idea that all nebulae were composed of stars, and he therefore included clusters, even rather scattered ones, in his observations, as representing with dense clusters and nebulae the different stages of the same class of bodies. But the discovery of some indubitably nebulous stars, or stars with atmospheres, made him recognise that there must be here and there in space some kind of "shining fluid" of which diffused nebulae and planetary nebulae were formed. This idea found very little favour among astronomers for many years, particularly after the completion of Lord Rosse's 6-foot reflector, the maker of which was inclined to think every nebula "resolvable." Yet Herschel was found to be right when Huggins proved many nebulae to have a gaseous spectrum.

Another discovery of Herschel's, which was doubted or denied until confirmed elsewhere, was the proper motion of the sun through space. Here there was perhaps some excuse for the doubters, as the material available for the investigation was rather scanty.

In order to get some idea of the distribution of the

stars Herschel for some years took observations of the star-density in various parts of the sky by counting the stars seen in the field of his telescope. Making two assumptions—that his telescope could reach the boundaries of the Milky Way, and that the stars of the system were tolerably uniformly distributed—he was able to construct a rough diagram of the shape of the Milky Way system to which our sun belongs. This is the well-known disc or grindstone theory, according to which the stars are scattered between two planes, roughly parallel to the belt of the visible Milky Way, with a stratum running out to one side to represent the bifurcation from Cygnus to Scorpio. Near the centre of this system (also spoken of as "our nebula") Herschel placed our sun. In after years, in two papers of 1817 and 1818, Herschel, as a result of his observations, was obliged to abandon the idea of uniform distribution, and also to recognise that his telescope could not reach the boundaries of the Milky Way system. But that the system extended very much further in the plane of the Milky Way than at right angles to it, remained his opinion, though the conception of the system being a nebula—that is, a star cluster—had been given up.

Here again there was, towards the end of the nineteenth century, a tendency to abandon Herschel's results, and the opinion was set forth in more than one quarter, that the Milky Way is really what it looks like—a huge ring-shaped cluster. It has even been suggested that it is a gigantic spiral nebula inside which our sun is situated—at first sight a rather tempting proposal. But recent researches by Shapley have shown these hypotheses to be untenable; and his work on the distribution of globular clusters, showing the enormous distances of many thousands of light-years which separate them from us, agrees in a remarkable manner with the ideas worked out by the old astronomer at Slough exactly a hundred years earlier, in the last paper he sent to the Royal Society. J. L. E. D.

## Obituary.

DR. ARTHUR RANSOME, F.R.S.

THE death of Dr. Ransome at Bournemouth in his eighty-ninth year recalls the memory of a Manchester physician who was a pioneer in the training of female health visitors, and in the investigation of tuberculosis and of the cyclical waves of epidemic diseases. He died on July 25; and by a striking coincidence, at the first meeting earlier in the same day of Section I.—that of Preventive Medicine—of the Congress of the Royal Sanitary Institute then being held in Bournemouth, a message of appreciation of Dr. Ransome's past work had been authorised, which never reached him.

Dr. Ransome was born in Manchester in 1834. He became an honorary fellow of Gonville and Caius College, Cambridge, and for many years was consulting physician of the Manchester Hospital for Consumption, as well as Professor of Hygiene and Public Health at Owen's College, 1880-95.

Dr. Ransome's chief writings related to tuberculosis, on which he published several books, as well as special

contributions to the Epidemiological and other Societies. He gave the Milroy lectures to the Royal College of Physicians on the causes of phthisis, and received the Parkes Weber prize for special researches on tuberculosis. From his experiments he concluded that finely divided tuberculous matter is rapidly deprived of virulence in daylight and in free currents of air; that even in the dark, fresh air has some, though a retarded disinfecting influence, and that in the absence of currents of air the tubercle bacillus retains its infectivity for long periods of time. The general effect of his work was to emphasise the importance of disinfection of rooms occupied by tuberculous patients. At the same time Dr. Ransome attached greater importance to sanitary and social improvements in the prevention of tuberculosis than to direct attack on the bacillus.

In epidemiology Dr. Ransome was one of the first to investigate the influence of cyclical waves in producing the intermittent prevalence of epidemic diseases, apparently independent of the accumulation of unprotected persons. The Swedish tables of mortality,

of unique historical duration, furnished him, as they did other investigators, with the data for the construction of charts, which showed, for example in scarlet fever, not only a short cycle for that country of four to six years, but also a long undulation of from fifteen to twenty years or more, which, as he said, might "be likened to a vast wave of disease upon which the lesser epidemics show like ripples upon the surface of an ocean swell" (Epidemiological Society's Transactions, 1881-82).

Dr. Ransome wrote much also on general public health subjects, always with a keen appreciation of the value of vital statistics and of the pitfalls to be avoided. Thus, in any population, except that of a life-table, in which births equal deaths and migration is absent, a death-rate of 10 per 1000 does not mean an average duration of life of 100 years. As he put it: "under present conditions such figures . . . can only be looked for in the millennium, when, as Isaiah says, the child shall die an hundred years old."

Dr. Ransome taught at an early date that "preventible" mortality extended far beyond epidemic diseases; and was singularly accurate in his forecast that infant mortality, which "had not yet received full attention from the sanitary administrators of the country," would hereafter prove largely controllable.

In a paper contributed to the *Lancet*, July 11, 1896, Dr. Ransome drew a striking comparison between leprosy and tuberculosis, arguing that in view of the close analogy between the two diseases there is reason to hope for a diminution of tuberculosis as striking as that already experienced in leprosy. The subject is too large to be expanded in this column, but this paper deserves to be consulted.

The above illustrations of some portions of Dr. Ransome's life-work show how wide were his studies and how prescient his teaching. A special shelf will always be reserved for his writings by students of tuberculosis and of general epidemiology. Many years ago Dr. Ransome retired to Bournemouth, where, until a few weeks before his death,—when the present writer received a letter from him on an epidemiological point,—he maintained his interest in his life-studies.

---

#### PROF. GIBERT KAPP.

By the death on August 10 of Prof. Gisbert Kapp, the country loses one of the few remaining pioneers of electrical engineering. Prof. Kapp was born at Mauer near Vienna in 1852, his father being German and his mother Scottish. At the Zürich Polytechnic he was a pupil of Zeuner and Kohlrausch. In 1875 he came to England, but spent several years afterwards in travelling on the Continent and in North Africa. He was appointed engineer to the Chelmsford Works of Messrs. Crompton and Co. in 1882, and in conjunction with Mr. (now Colonel) Crompton he invented a system of compound winding for dynamos. At this period England was the leading country in the world in electrical engineering. In 1886—the year in which John and Edward Hopkinson published their classical paper on dynamo design—Kapp read a paper on a similar subject to the Institution of Electrical Engineers.

He pointed out clearly the analogy between the magnetic circuit of a dynamo and an ordinary electric circuit. In this year also he published his book on the transmission of electrical energy which gave a very clear introduction to the whole problem. In the autumn of 1894 he accepted the post of secretary to the German Association of Electrical Engineers. He was also a lecturer to the Technical School at Charlottenburg and was editor of the *Elektrotechnische Zeitschrift*. In 1904 he was appointed the first professor of electrical engineering to Birmingham University.

As an inventor Kapp was in the front rank. The Kapp dynamos were very useful in their day. The Oerlikon Company, of Switzerland, built many large Kapp machines. But like all the other early types they are now superseded by machines with revolving fields and armature windings embedded in slots. Kapp also invented many types of measuring instruments, a method of making dynamos self-regulating, several types of transformer, a high-speed steam-engine, a system of distributing alternating currents, and a method of boosting the return feeders on electric railways. This last method has still considerable vogue in this country and in Germany.

Kapp was an excellent teacher. Many of the present-day electricians acquired their first ideas of the working of electric machinery from his books. His mathematical theorems were original and in several cases strikingly simple—for example, his formulæ for the free period of coupled alternators. He invented many laboratory methods of testing machines. His test for the efficiency of dynamos and his method of getting the moment of inertia of the rotor of a machine are particularly valuable. He also invented a method of getting the insulation resistance of a three-wire network without the necessity of shutting down the supply. He was one of the earliest to recognise the importance of the phase difference between the alternating current and the alternating potential difference. Developing the theory of the power factor he gave a very simple geometrical explanation of electrical resonance. In recent years he invented a vibratory type of phase advancer and pointed out that considerable economies might be effected by using these machines in everyday supply.

Kapp was a past president of the Institution of Electrical Engineers and was president of the Engineering Section of the British Association in 1913. Personally he was of a very kindly disposition and was always pleased to give his colleagues the benefit of his great engineering experience. He was most hospitable, and was learned in many branches of study outside his professional work. A. R.

---

#### MRS. J. A. OWEN VISGER.

READERS of natural history works at the end of the last century were somewhat mystified as to the authorship of a number of books published under the pen-name of "A Son of the Marshes," with the editorship of "J. A. Owen." The latter was the name under which Mrs. Jean A. Owen Visger preferred to be known, whose death at Ealing on July 30, in her eighty-first

year, we much regret to have to record. Mrs. Visger was a woman of considerable attainments, with a good deal of masculinity in her character, both mental and physical. She had an absorbing interest in anything appertaining to Nature, and her mind was a storehouse of material acquired during her long life. Her powers of observation were great, and she used to the full in her literary work the excellent memory which Nature had given her, and the many opportunities which travel afforded her.

The real "Son of the Marshes" was understood to have been a working naturalist in Surrey, but it is probable that J. A. Owen's editorship went a good deal further than mere editing. One might say, in effect, that the books were practically written by her. They contained much interesting natural history gossip, following the Richard Jefferies style, but, as a rule, the information was quite unlocalised, and so lost much of its scientific value. The books followed rapidly on one another, and amongst them may be mentioned, "From Spring to Fall," "With the Woodlanders and by the Tide," "Annals of a Fishing Village," "Within an Hour of London Town," "Forest Tithes," and "On Surrey Hills."

Mrs. Visger was twice married, first in 1863, in which year she went to live in New Zealand. There she remained for five years, visiting Tahiti and the Sandwich Islands. She returned to reside in England in 1876, and married again in 1883, afterwards travelling considerably in Europe and in the Pacific. She finally returned to England in 1913. Beside a few books of travel, Mrs. Visger wrote, "Forest, Field, and Fell," "Birds in a Garden," "Birds Useful and Birds Harmful," and in collaboration with the late Prof. G. S. Boulger, "The Country Month by Month." Her books are not now read, perhaps, so much as they deserve to be.

#### PROF. H. BATTERMANN.

HANS BATTERMANN, who died in Blankenburg, Harz, on June 15, at the age of sixty-two, has left a record of much useful work in astronomy. In his youth he studied at Berlin University under Förster and Tietjen, gaining the degree of doctor in 1881 for a dissertation on aberration. After a short period at Hamburg Observatory he returned to Berlin as a member of the Commission which was appointed, under the direction of Auwers, for the discussion of the results obtained at the transits of Venus in 1874 and 1882. During this period he observed a long series of occultations of stars by the moon, utilising them to obtain a value of the moon's parallactic inequality, and hence of the solar parallax; the value that he found for the latter was  $8\cdot789''$ , which is a good approximation to the accepted value; a still longer series of occultations, observed near the first and last quarters of the moon, should give a very accurate solar parallax. Battermann also conducted two other useful investigations at this time, one on the nature of the images in a heliometer, the other a triangulation of the Pleiades with that instrument. In 1888 he observed for nine months at the Göttingen Observatory; on his return to Berlin he took the chief part in the star observations with the transit circle, and in their reduction to a Catalogue, including the discussion of proper motions.

In 1904 Battermann was appointed professor and director of the University Observatory at Königsberg; he continued there his researches on proper motion, and also observed further occultations with the 13-inch refractor. He was compelled to resign his professorship in 1919 through a complete breakdown in health, brought on by overwork; he retired to Blankenburg, where he died three years later, after much suffering.

A. C. D. C.

### Current Topics and Events.

DR. M. O. FORSTER, who, since November 1918, has been director of the Salters' Institute of Industrial Chemistry, is relinquishing this post at the end of next month, having been appointed director of the Indian Institute of Science, Bangalore. He expects to take up his new duties early in November.

A NEW biological station for the study of limnological problems and for research on the development of fresh-water fishes has been established at the Lake of Trasimeno, in Umbria. The University of Perugia has assumed responsibility, and the director of the station is the professor of physiology, Dr. Osvaldo Polimanti. Further details of the equipment are promised at an early date.

THE excavations at the Meare Lake Village, near Glastonbury (Shapwick and Ashcott are the nearest stations), will be resumed by the Somersetshire Archaeological and Natural History Society on August 25, and continued until September 9 (exclusive of the filling-in). As in previous years, the work will be under the personal direction of Dr. Arthur Bulleid and Mr. H. St. George Gray. The antiquities discovered in past years at Meare are exhibited in the

Somerset County Museum at the society's headquarters, Taunton Castle, while those from the Glastonbury Lake Village (described in two royal quarto volumes) are to be seen, for the most part, in the Museum at Glastonbury. Donations are needed and will gladly be received by Mr. St. George Gray, at the Somerset County Museum, Taunton.

ONE of the oldest organised scientific societies, the "Schweizerische Naturforschende Gesellschaft," is holding its 103rd Annual Meeting at Berne on August 24-27. In addition to the usual business of the society, there will be scientific discussions, and a number of important papers will be read, including: "The Trend of Modern Physics," Dr. C. E. Guye (Geneva); "The Nature of the so-called General Neuroses," Prof. Sahli (Berne); "The Aar Massif—an Example of Alpine Granitic Intrusion," Dr. E. Hugli (Berne); "The Natural Form of Substances as a Physical Problem," Dr. V. Kohlschütter (Berne); "Experimental Genetics in regard to the Law of Variation" (illustrated by lantern slides), Dr. A. Pictet (Geneva); and "Investigations into the Physiology of Alpine Plants," Dr. G. Senn (Bâle). Banquets will be held at the end of each session, and there will be concerts



and other social functions. Those wishing to take part in the meetings may do so on payment of a fee of thirty francs, payable to the "Postcheckkonto No. III. 1546" of the "Naturforschende Gesellschaft," Berne.

AMONG the Civil List Pensions granted during the year ended March 31, 1922, and announced in Parliamentary Paper, No. 137, just published, we notice the following:—Lady Fletcher, in recognition of the services rendered by her late husband (Sir Lazarus Fletcher) to science, and in consideration of her circumstances, 60*l.*; Dr. Francis Warner, in recognition of the services rendered by him in his investigations into the mental and physical condition of defective children, and in consideration of his circumstances, 100*l.*; Sir George Greenhill, F.R.S., in recognition of his services to science and his ballistic work, and in consideration of his circumstances, 125*l.*; Mrs. J. M. Miller, in recognition of the services rendered by her late husband (Dr. N. H. J. Miller) to agricultural science, and in consideration of her circumstances, 50*l.*; Mrs. Alice Mabel Ussher, in recognition of the services rendered by her late husband (Mr. W. A. E. Ussher) to geological science, and in consideration of her circumstances, 50*l.*; Mrs. Agnes E. Walker, in recognition of the services rendered by her late husband (Mr. George W. Walker, F.R.S.) to science, and in consideration of her circumstances, 75*l.*; The Misses Ellen C., Gertrude M., Alice B., Katherine E. and Mary L. Woodward, in recognition of the services rendered by their late father (Dr. Henry Woodward, F.R.S.) to geological science, and in consideration of their circumstances, 125*l.*

ON August 19, 1822, a hundred years ago, died Jean Baptiste Joseph Delambre, the illustrious astronomer and permanent secretary to the Paris Academy of Sciences. Born in Amiens, September 19, 1749, Delambre became a student in Paris and first gained a livelihood as a translator and a tutor. A friendship with Lalande led him to astronomy, and among his earlier work was the formation of tables of Herschel's newly-discovered planet Uranus. With the revolution came the proposal for a rational system of weights and measures, and on the formation of a commission to carry the scheme through, Delambre and Méchain were instructed to measure an arc of meridian from Dunkirk to Barcelona. Often interrupted, this great work occupied the years 1792 to 1799, while the results were given fully in Delambre's "Base du Système métrique decimal," published in 1806-10. Various appointments fell to Delambre; in 1807 he succeeded Lalande at the Collège de France, and as secretary to the Academy of Sciences he wrote many *éloges* and reports. His later years were largely devoted to the writing of his great history of astronomy, five volumes of which appeared during 1817-1821, while the final volume was published five years after Delambre's death. Delambre is buried in the Père la Chaise Cemetery.

MR. H. G. SMITH, formerly assistant curator and economic chemist at the Sydney Technological Museum, has been awarded the David Syme Research prize of the University of Melbourne. The prize, which consists of a medal and a sum of 100*l.*, is awarded for the best thesis based upon original scientific research connected with the material and industrial development of Australia. Mr. Smith is the leading authority upon the chemistry of the essential oils of the eucalypts. Working largely in collaboration with his botanical colleague, Mr. R. T. Baker, and as a result of nearly thirty years' assiduous research, he has been able to establish a remarkable correlation between chemical and botanical characteristics in this complex genus, and an evolutionary theory accounting for the formation of the various species of Eucalyptus has been advanced by him and Mr. Baker. Since his retirement from the Sydney Technological Museum, Mr. Smith, although in his seventieth year, has been actively engaged in further work in the Organic Chemistry Department of the University of Sydney, in association with Prof. Read.

IN accordance with its policy of promoting scientific investigation in Australia, the Australian National Research Council has decided to publish a quarterly catalogue, comprising a list of titles, authors, and journals of publication of scientific research papers of Australian origin, whether appearing in Australian or other journals. The catalogue, which will also contain a brief abstract supplied by the author of each paper concerned, will be entitled *Australian Science Abstracts*, and will be under the control of an editorial committee representing the various branches of science corresponding with the sectional arrangement. The personnel of the editorial committee is as follows: Prof. H. G. Chapman, Dr. L. A. Cotton, Mr. J. J. Fletcher, Mr. A. Gibson, Prof. J. Read, Prof. O. U. Vonwiller, Mr. G. A. Waterhouse, and Prof. R. D. Watt, with Dr. A. B. Walkom as editor-in-chief. The catalogue will be published in Sydney; it will be issued free of charge to members and associates of the Australian National Research Council, and a number of copies will be used for exchange purposes. It is hoped to issue the first number this month.

EXCEPTIONALLY heavy rains fell in many parts of England during the August Bank-holiday week-end and the following days, causing not only discomfort but doing also a large amount of damage in several districts. The primary cause of the rainfall was the arrival of a cyclonic disturbance from the Atlantic, the core or centre of the storm being situated near the Land's End at 8 A.M. on Sunday, August 6, reaching Portland by 2 o'clock in the afternoon, and passing over the Isle of Wight at 7 o'clock in the evening. It was a few miles to the north-west of London at 8 A.M. on August 7, and passed over Cambridge at 2 o'clock in the afternoon, reaching Spurn Head by 7 o'clock in the evening. The disturbance had arrived near Flamborough Head at 2 A.M. on August 8 and afterwards passed away over the North Sea, but the arrival of another disturbance occasioned a renewal

of the rains. During the 12 hours ending 6 P.M. on August 6 the fall of rain at Bournemouth was about 1½ inches. At Harrogate the aggregate rainfall was nearly 5 inches for the three days ending Wednesday, August 9. Nottingham registered 3.4 inches of rain for the 24 hours ending 7 P.M. on August 7. Sheffield experienced exceptionally heavy rain on this date, which occasioned floods, and there was a renewal of the floods in the late evening of the following day. At Leeds, between the morning of August 7 and mid-day of August 9 the rainfall measured 3.44 inches, which is said to be the highest ever recorded in the city. At Melton Mowbray the rain measured 4.83 inches for the 24 hours ending 9 P.M. on August 7, and at Doncaster the measurement was 4.08 inches between midnight on August 6 and 6.30 P.M. on August 7. Violent thunderstorms occurred generally in the south and east of England, and in London on the afternoon of August 9 a storm was accompanied by a heavy fall of hail. At Hampstead the hailstones remained unmelted on the ground for several hours.

SWAROW, situated on the China coast at the mouth of the river Han and in the Formosa Strait, was visited by a typhoon of terrific violence during the night of August 2-3; the storm lasted about six hours, starting at 10 P.M. on August 2. The pre-war population of Swatow is given as 60,000, and an estimate, made a week after the disaster, of the loss

of life at Swatow and the surrounding district is said to be probably 50,000. Six other towns besides Swatow are said to be destroyed. The water rose quite suddenly, partly submerging houses and buildings. Trees were uprooted and telegraph poles blown down. Sampans and native craft were blown hundreds of yards inshore, most of the occupants being drowned, and many large vessels were driven ashore. More than 2000 vessels annually enter the port. The occurrence and characteristics of typhoons in the China Seas have long been studied and are comparatively well understood. The recent storm was probably one of the type shown in the "Barometer Manual for the use of Seamen" published by the Meteorological Office. The period of occurrence is from June to September. These storms usually originate in the neighbourhood of the Philippines and travel northward or north-eastward, striking or skirting the China coast and afterwards passing near to Korea and Japan. The typhoons are commonly warned from Manila or Hong-kong, but the warning can, at the best, only lessen the amount of damage. The Hong-kong Government has greatly aided in relieving the distress occasioned, and the British have been helped in this by the Japanese. In the Backergunge, Bay of Bengal, cyclone, in October 1876, the loss of life by drowning was estimated at 100,000, and the deaths afterwards from disease directly due to the inundation added another 100,000 to the number.

### Our Astronomical Column.

CONJUNCTION OF VENUS AND JUPITER.—A conjunction of these brilliant planets will occur on August 26 at 18h. G.M.T., when Venus will be  $2^{\circ} 29'$  south of Jupiter. Venus will set at 8h. 11m., and Jupiter will set at 8h. 24m. G.M.T. Sunset occurs at 7h. G.M.T., so that the two planets will set about 1½ hours after the sun. Twilight will be very strong in the western sky just before the setting of the two planets, and in order to observe them it will be necessary to look from a position which commands a clear open view of the western sky near the horizon.

On August 25 Venus and Jupiter will be in conjunction with the moon soon after midnight following the date mentioned, and on August 30 will be in conjunction with Mars in the evening. The western sky during the last week of August will be extremely interesting, the new moon being there and Venus, Jupiter, and Saturn also visible in the same region.

THE ORBITAL DISTANCES OF SATELLITES AND MINOR PLANETS.—Prof. G. Armellini in 1918 published a law of planetary distances in the form  $1.53^n$ , where  $n$  is given successive integral values from -2 for Mercury to +8 for Neptune. The two integers +2 and +3 are assigned to the asteroids, while +6 is left unused. It can scarcely be claimed that (except in the case of Neptune) it shows great superiority over the law of Bode. However, in a further paper (*Scientia*, August 1922) he notes that his colleague Prof. Burgatti has applied the law to the satellite systems of Jupiter, Saturn, and Uranus, the formulae

being  $1.80^n$ ,  $1.34^n$ , and  $1.31^n$  respectively. In the case of the Jupiter family the indices are -3, -2, -1, 0, +1 for V and the four bright satellites; +2, +3 are unused, +4 is assigned to the two satellites VI, VII, while +5, +6 are given to VIII, IX respectively. The author erroneously gives a distance to IX half as great again as that of VIII. The two in reality form a twin pair like VI, VII. Since the law gives no explanation of vacant spaces or of pairs of satellites, its claims to rest on a physical basis are not convincing.

The remainder of the paper deals with the asteroid-orbits. The gaps at the distances where the periods are half and one-third of Jupiter's are not ascribed to the direct action of that planet, but to some primitive agency which determined both its distance and theirs. It is, indeed, likely that the asteroids will play an important part in future discussions on the cosmogony of the solar system.

Prof. Armellini cites an interesting point about planet 434 Hungaria. Its distance from the sun, 1.95, is the precise distance at which Leverrier stated that enormous perturbations in inclination would develop, causing oscillations of  $53^{\circ}$ . Charlier, however, pointed out that Leverrier had included only first-order perturbations; he estimated that the inclusion of higher terms would diminish the oscillation to  $17^{\circ}$  or less. Finally, Prof. Armellini himself has effected the complete integration of the expressions, using elliptic functions, and finds that the oscillation of the inclination is only  $3\frac{1}{2}^{\circ}$ , a quantity of the same order as that of the major planets.

## Research Items.

**COLOUR SYMBOLISM.**—In the June issue of *Folklore* (vol. xxxiii. No. 2) Mr. D. A. Mackenzie contributes a paper on colour symbolism, which contains a mass of interesting facts. Egyptian colour symbolism was already old at the dawn of the Dynastic period. In ancient Europe it was restricted by the conventions of Cave art, and the range of colours used by the Cro-Magnon artists was limited and confined to earth colours only. There is clear evidence, however, that people in Aurignacian, Solutrean, and Magdalenian times attached a symbolic value to certain, if not to all, colours. Small green stones were placed between the teeth of some of the Cro-Magnon dead interred in the Grimaldi caves near Mentone—an interesting fact in connexion with the ancient Egyptian belief in the magico-religious value of green stones. The writer is, however, mistaken in extending the analogy to China, where, it is said, green jade was placed in the mouths of the dead; on the contrary, the use of green jade for this purpose was exceptional.

**JURASSIC BIRDS.**—Dr. Branislav Petronievics, who has published several papers on fossil vertebrates in the *Annals and Magazine of Natural History*, now states the results of his examination of the original specimen of *Archaeopteryx macrura* preserved in the British Museum (*Natural History*) in a paper ("Über das Becken, den Schultergürtel und einige andere Teile der Londoner Archaeopteryx") published separately by Geogr and Co. of Geneva. His most important conclusion is stated so modestly on p. 10 that it might easily escape recognition. He feels that the differences between the Berlin and London specimens referred to *Archaeopteryx*, which caused Dames to separate the Berlin bird as *A. Siemensii*, are sufficiently increased by his recent researches to allow of the formation of two genera. He proposes therefore to include in the established order Archaeornithes, Archaeornis, the Berlin specimen, and *Archaeopteryx*, the London specimen. The latter (p. 18) is held to be the more primitive type, and the shoulder-girdle (p. 24) even suggests that the two genera should fall into different families. The author perceives an early carinate type in *Archaeornis* and an early ratite type in *Archaeopteryx*, and indicates that a convergence of the two important divisions of birds should be found farther back in some descendant of the Lacertilia. The dinosaurs lie on a separate branch, converging with the bird-branch in some ancestral reptile. We should like to have Dr. Petronievics's views on *Compsognathus* and *Podokesaurus* (*NATURE*, vol. 109, p. 757).

**MOSQUITO CONTROL.**—Apart from certain wartime measures in the neighbourhood of a few military camps, scarcely anything has been attempted in this country in the way of the reduction of mosquitoes, but an example has recently been set by the Hayling Mosquito Control, which, under the direction of Mr. John F. Marshall, is doing very useful work, both practically and experimentally. The Report just issued by this body summarises what has been done since its foundation in the autumn of 1920. It was found that in Hayling Island the two common domestic species (*Culex pipiens* and *Theobaldia annulata*) were almost negligible as pests, by far the greater part of the annoyance being caused by the salt-marsh species (*Ochleotatus detritus*). So numerous was this species that it was roughly calculated that two million larvae were destroyed by raffinating in a single afternoon. Although last year's drought did not seriously restrict the breeding-places of *O. detritus*,

the control measures adopted proved very effective, as was shown by comparison with other places along the south coast. The very successful use of soluble cresol in small quantities as a larvicide has already been described in *NATURE* by Mr. Marshall (June 10, 1922, p. 746). Important experiments are now being carried out to ascertain if possible the range of flight of *O. detritus*. Some kinds of salt-marsh mosquitoes, especially in North America, have been shown to make large migrations for distances of many miles. If *O. detritus* shares these habits local control work may be rendered largely unavailing, though the comparative immunity already obtained by the control goes far to show that this is not the case.

**PHILIPPINE FORAMINIFERA.**—Mr. J. A. Cushman has published (*Bull. 100*, Smithsonian Institution, U.S. Nat. Mus.) a monograph on the Foraminifera of the Philippine and adjacent seas, based on material from shallow water and from nearly 600 dredgings. The shallow water examples—from less than 30 fathoms—are characteristically tropical, most of the genera being those of similar areas in the general Indo-Pacific region, many of the species being, however, distinct. In the deeper water, 100-300 fathoms, there is an exceptional development of the Lagenidae, and in the colder deeper parts of the region a great development of arenaceous forms, especially Astrohizidae and Lituolidae—many of the characteristic genera and species of cold waters in high latitudes being represented. This supports the view that the wide distribution of these arenaceous forms in cold waters is dependent more on temperature than on depth. The largest of the living calcareous Foraminifera, *Cyclocyptus carpenteri*, of which specimens about 2½ inches in diameter were obtained, was dredged in quantity in parts of the area. The systematic part of the work records 568 species and gives notes on their characters and distribution; figures of the more important species are given in 100 plates.

**THE MICROSCOPIC DETERMINATION OF THE NON-OPAQUE MINERALS.**—The method of identifying minerals by determining their indices of refraction by immersing or embedding their powders in media of known refractive index receives immense extension through Esper S. Larsen's memoir bearing the above title (*U.S. Geol. Survey, Bull. 679, 1921*). The tables given contain data for about 950 mineral species, and the methods of determination are adequately described.

**PRE-DEVONIAN GEOLOGY OF GREAT BRITAIN.**—The Quarterly Journal of the Geological Society, vol. lxxviii. pt. 2, 1922, shows how much work has remained to be done on the stratigraphy of our older British areas. Mr. E. B. Bailey develops his theory of *nappes* in the south-west highlands of Scotland, arousing thereby a healthy and critical discussion. Dr. Gertrude L. Elles gives in detail the results of her zoning of the rock-succession in the Bala district; and Dr. J. Wills and Mr. Bernard Smith have greatly extended our knowledge of the country round Llangollen.

**NEW RADIOLITES AND A NEW CRINOID FROM THE UPPER CRETACEOUS OF MEXICO.**—Examples of those strange aberrant bivalves the Radiolitidae from the Upper Cretaceous of Tamaulipas, Mexico, where they appear to be scarce, have been described and figured by L. W. Stephenson (*Proc. U.S. Nat. Mus.*, lxi. art. 1), who, however, favours Lamarck's later name in his title and refers to them as belonging to the "Rudistid Group." A new genus, *Tampsia*, with two new

species; three species, of which two are new, of Sauvagesia; and a new species of Durania complete the series. Among the associated fossils cited is *Balanocrinus mexicanus*, n.sp., which forms the subject of a separate paper by F. Springer (tom. cit., art. 5). This is the first known occurrence of the genus in America.

THE FLOTATION OF CONTINENTS.—M. E. Gagnebin, of the University of Lausanne, has provided a masterly review of Wegener's hypothesis of the movement of continental masses over the general surface of the globe. In ten pages of the *Revue générale des Sciences naturelles*, vol. xxiii. p. 293, 1922, he states the main features of the argument, discusses the problems raised, and furnishes references and footnotes that make his lucid essay an almost essential introduction to Wegener's "Entstehung der Continente" (see NATURE, vol. 109, pp. 202 and 757). It is interesting to notice that the relations of folded zones to those of subsidence on the earth is one of the subjects discussed at the International Geological Congress in Brussels in August 1922.

THE MATRIX OF DIAMOND.—The question of whether diamond separates out from ultrabasic igneous magmas, or is carried up in these exceptional magmas because they have traversed deep-seated metamorphic rocks, is once more raised by the description of the diamond-bearing gravels of the Somabula Forest in Southern Rhodesia (A. M. MacGregor, Geol. Surv. S. Rhodesia, Bull. 3, 1921). These fluviatile beds form part of the Karroo system, and the kimberlite pipes of S. Africa are of later date. The author suggests that the diamonds were washed from a kimberlite of unusually early age, since he favours the view of their igneous origin. New interest is given to the kimberlite pipes of Africa by H. S. Harger's discovery (Trans. Geol. Soc., S. Africa, vol. xxiv. p. 1, 1922) that an example in the Riversdale district of the Cape Province cuts strata of Uitenhage (Cretaceous) age.

CRITICAL RESEARCH ON FOSSIL BRACHIPODA.—The transference of well-known species to new genera as investigation becomes more precise often leaves little to be said for an original genus the name of which has become known throughout the world. This is sadly the case with Rhynchonella, to which Mr. S. S. Buckman (Mem. Geol. Surv. India, Palaeontologia Indica, New Ser., vol. 3, Mem. 2, "The Brachiopoda of the Namyian Beds, Northern Shan States, Burma") now assigns only two species, *R. loxia* Fischer of the Portlandian, and *R. variabilis* Davidson of the Kimmeridgian (p. 57). The author quotes (p. 91) his previous conclusion that no Mesozoic species can be assigned to Terebratula Müller, 1776. On pp. 8 to 11 he describes his method of "burning" specimens of fossil brachiopods; when the shells are heated and dropped into water, it commonly flakes off from the internal cast, and the characteristic muscular scars are clearly traceable on the mould. Much, of course, depends on the infilling material, and oolitic limestone yields poor results. The method has been elaborated by Mr. Buckman from an observation by Mr. T. H. D. La Touche (p. 2), who noticed that the fossils fell out easily from material that had passed through Burmese lime-kilns, and who proceeded to treat his rocks in a big fire "with very satisfactory results."

EVOLUTION OF THE GRAPTOLITES.—The numerous geologists who wish to keep abreast of progress in the classification of Older Palaeozoic strata will find much guidance in a paper by Dr. Gertrude Elles on "The Graptolitic Faunas of the British Isles" (Proc. Geol. Assoc. vol. 33, part 3, 1922; price 5s.). Since it seems

uncertain if hydrozoan, or even coelenterate, affinities can be maintained for graptolites and their allies, a separate class of organisms, the Graptolithina, has been established, subdivided into two orders, the rapidly changing Graptoloidea and the almost stationary Dendroidea. In the same prudent spirit the term rhabdosome replaces polypary, and theca hydrotheca. The virgula of older descriptions of graptolites disappears. Attention is well directed to the nema, the hollow thread-like prolongation of the apical portion of the sicula, as being the organ of attachment essential to the welfare of the rhabdosome. In the earlier pendent graptolites the nema is unprotected; but in forms regarded as scandent, such as Diplograptus, and also in some uniseriate genera, it is protected, and is sometimes wrapped round the bases of the thecae. Many of the points mentioned are quoted from work published by the author and other investigators, and recognised by modern writers, such as A. M. Davies; but the present summary, the clear diagrams of types successively evolved, and the stratigraphical table, render this paper by Dr. Elles valuable in all colleges as a supplement to established text-books of palaeontology.

VERTICAL CIRCULATION IN THE ATLANTIC.—A. Merz and G. Wüst (*Zeitschrift der Gesellschaft für Erdkunde*, Berlin, 1922, No. 1-2) discuss the nature and cause of the vertical circulation of the water of the Atlantic Ocean, reviewing the various descriptions and explanations so far published. It has been known, in a general way, that water which is relatively warm and fresh flows on the surface from the region of equatorial rains and calms north and south to the sub-tropical zones, while water which is relatively cold and dense flows in the opposite directions as under-currents. This system of drifts now appears to be of very limited depth. The superficial warm currents extend to about 50 metres while the under-currents have their main stratum at a depth of 75-150 metres from the surface. The cause is differences of density rather than differences of temperature.

DUST-RAISING WINDS.—This subject is dealt with in the Memoirs of the Indian Meteorological Department, vol. 22, part 7, by Dr. C. W. B. Normand. Observations were made on dust phenomena in Mesopotamia in 1918, and these, together with Dr. Hankin's observations in a preceding memoir, are correlated with those of other observers in other countries. The camp in Mesopotamia was situated at Samarra, near the edge of the vast low plateau known as Jezirah, where the dust in places lay knee-deep. With even light winds in August and September it was no uncommon occurrence to see three or four dust-devils of great height meandering with the breeze on the plain. The base of many of these was only about 5 metres in diameter and the height was at least 300 metres. For the origin of dust-devils a highly unstable vertical distribution of temperature is said to be a necessity. At Samarra the author attributes the impetus to be often due to the incinerators at the various camps for burning refuse. The "primary" dust-storm in Mesopotamia occurs principally between 4 P.M. and midnight in the months of March, April, May, and September; they are always associated with cloud, and were often followed by rain, thunder, and a marked fall in air temperature. The dust-storms in spring are almost always associated with thunderstorms and are said to be undoubtedly due to the descending currents which are known to occur in front of thunderstorms. Interesting information is given on the cause of dust-raising by wind, and on turbulence and the density of dust at various heights.

## The Hull Meeting of the British Association.

## PROGRAMMES OF THE SECTIONS.

THE programmes of the various Sections of the British Association for the forthcoming meeting at Hull have now been provisionally completed, and it is possible to state what are the chief subjects to be brought forward. We are indebted to the Recorders of the Sections for the subjoined outline of arrangements made for the meeting.

**SECTION A (MATHEMATICS AND PHYSICS).—**The proceedings of Section A this year promise to be of more than usual interest. The Section is fortunate in having secured the attendance of three very distinguished foreign guests, Prof. P. Langevin, Prof. P. Weiss, and M. le Duc de Broglie. The two former will take part in a discussion which has been arranged on the origin of magnetism, to which Sir J. A. Ewing and Dr. A. E. Oxley have also promised to contribute. M. de Broglie will read a paper, which cannot fail to attract great interest, on X-rays and Beta rays, and as Prof. R. Whiddington will make a communication on the same subject, a valuable discussion on this aspect of physics may be expected. Prof. G. H. Hardy has chosen as the subject of his presidential address "The Theory of Numbers," and it may be confidently anticipated that he will make it of that fascinating interest which is an attribute of all his lectures. An important and somewhat novel joint discussion will take place under the auspices of Sections A and I on physical instruments for biological purposes. Prof. A. V. Hill will open this discussion, and several biologists and physicists have promised to take part. In connexion with this discussion there will be an extensive exhibition of appropriate apparatus by Major W. S. Tucker, Mr. F. E. Smith, Dr. G. Wilkinson, and The Cambridge and Paul Scientific Instrument Company. In view of the success attending the experiment at Edinburgh last year, the Committee of Section A has arranged several lectures of a semi-popular character. Sir William Bragg will lecture on "The Significance of Crystal Analysis"; Prof. J. Proudman has chosen a subject especially appropriate to Hull, namely, "Tides, with Special Reference to the North Sea"; and Prof. H. H. Turner will delight the children with the topic, "The Telescope and what it tells us."

**SECTION B (CHEMISTRY).—**The programme of Section B will include several discussions. Principal Irvine has selected research problems in the sugar group as the subject of his presidential address, and this will be followed by several papers on carbohydrates from the St. Andrews laboratories. Photosynthesis will be discussed jointly with Section K (Botany), the recent work from the Liverpool laboratories on the synthesis of the more complex plant products being well represented. Sir William Bragg will describe his researches on the crystalline structure of organic compounds; and the recent theories of organic structure will be considered in a discussion on valency and polarity, to be opened by Prof. Robinson, and in a paper by Prof. Holleman on substitution in the benzene nucleus. Other separate papers include an account of the recent work on compressibilities under high pressures conducted in the Geophysical Laboratory at Washington, and a study of the properties of soap solutions by Prof. McBain. Two discussions of industrial questions have been arranged. One of these concerns the local industry of the hydrogenation of fats, which will be considered from the scientific and the industrial side, and the other is the industry of synthetic nitrogen compounds. Several of the modern processes of

synthesis will be described. The city is an important centre of chemical manufactures, and visits of the Section to some of the principal works, including the fat and oil and the cement industries, have been arranged.

**SECTION C (GEOLOGY).—**As a part of the series of discussions on questions connected with the North Sea to be held in various Sections, the first item in the programme will be an account by Prof. Kendall of the geological history of the North Sea Basin from Permian times to the present day. This will be followed by an account of the floor deposits of the North Sea and by a general discussion of these topics. The geology of the Hull district will be described by Mr. T. Sheppard, whose lecture will be illustrated by lantern slides. Other communications on local geology are the erosion of the Holderness Coast, by Mr. C. Thompson; a new section in the Oolites and Glacial deposits at South Cave, by Mr. J. W. Stather; and a new section in the Oolites at North Ferriby, by Mr. W. S. Bisat. Pleistocene and Recent ice conditions in North-eastern Labrador will be described by Prof. Coleman of Toronto. The subject of the presidential address by Prof. P. F. Kendall is the physiography of the coal swamps. The address will be followed by Prof. Gilligan on sandstone dykes in the Cumberland coalfield and the subjects raised in the two communications will be discussed. A discussion on Wegener's hypothesis of continental drift, in which both the geological and astronomical sides will receive attention, has been arranged, and the relation of early man to the phases of the ice age in Britain will form the subject of a joint meeting between the anthropological, geological, and geographical sections. Papers dealing with the zoning of Carboniferous rocks will be read by Mr. W. S. Bisat and Mr. R. G. Hudson, and Dr. H. L. Hawkins will describe the relation of the Thames to the London Basin. Numerous excursions will be held during the meeting.

**SECTION D (ZOOLOGY).—**The organising committee of Section D, the president of which is Dr. E. J. Allen, has shaped its programme for the forthcoming meeting at Hull with the view of relating it so far as possible to local interests. Four of the eight sessions will be devoted to marine biological and fisheries problems; the remaining four to matters of a wide variety of interest. One whole day will be given to discussion with representatives of the fishing industry, when members of the industry will propound difficulties and questions which the biologist will endeavour to answer to the limits of his knowledge, and which he will, it may be hoped, take to heart against the planning of further investigations. Another feature of the meeting will be the number of distinguished foreign marine biologists who will attend. Dr. Hjort, of Norway, will give an evening lecture at Grimsby, Dr. C. J. Joh. Petersen will come from Denmark to open a discussion on the fauna of the sea bottom, of the quantitative study of which he is the pioneer, Dr. Johs. Schmidt will give an account of his recent explorations in the Atlantic, and there will be eleven other distinguished oceanographers, including representatives from Belgium, Denmark, France, Holland, Norway, and Sweden. It is anticipated that a representative gathering of research vessels will also attend, including, in addition to our British vessels, the Danish *Dana*, the French *Pourquoi Pas*, and the Swedish *Skagerak*. Of items other than those concerned with marine biology one will be a discussion

with Section K (Botany) on the present position of Darwinism, when the views of Dr. Willis and Mr. Yule, as put forward by themselves at the meeting, will come under review and criticism. Among the individual contributions it is difficult to particularise; they will deal with problems relative to hormones, hydrogen ion concentration, forestry, geographical distribution, hereditary transmission of small variations, adaptation, periodicity of pond protozoa, and the effect of lead pollution. The final but not the least important item on the programme is a discussion with the Hull naturalists on the possible work of natural history societies in relation to faunal surveys.

SECTION E (GEOGRAPHY).—The presidential address by Dr. M. I. Newbigin will be on Human geography: first principles and some applications. On the same day Miss E. C. Temple will speak on the influence of geographical conditions upon ancient Mediterranean agriculture. Several speakers will deal with current problems in Europe, including Prof. J. F. Unstead on the belt of political change in Europe, and Mrs. H. Ormy on the Danube as a waterway. Prof. P. M. Roxby will lecture on the place of Peking in the life of modern China, and Dr. Vaughan Cornish, in a paper entitled the isothermal frontier of ancient cities, will develop the interesting thesis that from the North Sea to the Sea of Japan the separation between city life and that of forest and prairie people is marked by the same mean annual isotherm. Local geography will be treated by Mr. L. Rodwell Jones, Mr. C. B. Fawcett, and others. There will be a number of papers on cartography and survey, including survey in polar regions, by Mr. F. Debenham; the mapping of Latin America, by Mr. A. G. Ogilvie; early maps of Malta, by Dr. T. Ashby; and a discussion on the use of Mercator's projection for air-maps, which, it is hoped, will be opened by Col. E. M. Jack. A joint discussion, with the cosmical subsection of Section A, on the monsoons, will be opened by Dr. G. C. Simpson. Section E will also take part in a joint discussion with Sections C and H on relations of early man to phases of the ice age in Britain. Travel will be represented by Sir P. Brocklehurst on his recent journeys through Wadai, Mr. R. R. Walls on his extensive wanderings in Portuguese Nyasaland, and Mr. R. A. Frazer on some work in Spitsbergen. In economic geography Mr. H. M. Spink will speak of some geographical aspects of recent developments of water power, Mr. A. V. Williamson on irrigation in the Indo-Gangetic alluvium, and Mr. D. C. T. Meckie on the trend of world commerce. An excursion to Spurn Head and Sunk Island is being arranged.

SECTION F (ECONOMIC SCIENCE AND STATISTICS).—The influence which the war has had upon our economic life is again the subject of several of the papers which are to be read in this section. Prof. A. L. Bowley will continue his studies of post-war prices in a paper comparing wholesale and retail prices since the Armistice; and Mr. W. H. Whyte is contributing a paper on the war and its influence on stock markets. The questions of unemployment and of out-door relief are to be dealt with by Mr. J. L. Cohen in a paper on the future of unemployment insurance; and by Miss Anne Ashley, who has had considerable experience of social work in Edinburgh, and is contributing a paper on the English and Scottish Poor Law in relation to the able-bodied. The measurement of productivity in agriculture and industry is to be dealt with by Mr. R. B. Forrester; human motive in industry by Miss H. Reynard; and modern municipal markets and their economic significance, by Prof. J. G. Smith. The president of the section is Prof. F. Y. Edgeworth, and his address will deal with the question of equal pay to men and

women for equal work. In addition to the papers there are to be two important discussions with other sections—the first with the Sections of Agriculture and Physics (Meteorology) on weather cycles in relation to agriculture and industrial fluctuation. It will be opened by Sir William Beveridge and Mr. R. A. Fisher. The second discussion is with the Agriculture Section, and is to discuss the possibility of increasing the food supply of this country. Sir Henry Rew, Sir John Russell, Mr. C. S. Orwin, Sir Thomas Middleton, Prof. Somerville, and Prof. Cannan have promised to speak. Both these discussions deal with very urgent problems at the present time, and they should prove of considerable interest not only to members of the Association but to the general public.

SECTION H (ANTHROPOLOGY).—This Section has a varied programme, in which matters relating to archaeology predominate. It includes two organised discussions—one dealing with the antiquity of man in relation to the ice age in Britain, which will take place in a joint session with the Geological and Geographical Sections, and one, to be held in a joint session with the Psychological Section, on mental characters and race, which will be opened by Prof. J. L. Myres. One morning session will be devoted to questions relating to the archaeology and anthropology of the north-east coastal area of England, when Mr. Leslie Armstrong will discuss the Maglemose remains of Halderness and their Baltic counterparts, Mr. W. G. Collingwood will deal with the influence of Scandinavia on the art of the Danelaw in the tenth century, and Prof. A. Mawer will consider the place-names of the East Riding. In connexion with this group of subjects Prof. A. W. Brøgger of Christiania will describe the burial found in a Viking ship at Oseberg, which is of great importance for our knowledge of Scandinavian art and culture in the ninth century. Lord Dunsany will describe recent finds of palaeolithic implements in North Africa, and Mr. Seton-Karr will deal with aspects of the same subject; Miss Nina F. Layard will discuss prehistoric cooking places, and the excavations carried out by the Speleological Society of Bristol University in caves in the Mendips, which have brought to light remains of the late Palaeolithic and Iron Ages, will be described by Mr. E. K. Tratman and Mr. J. A. Davies. A communication by Mr. Cyril Fox, which is likely to give rise to an interesting discussion, deals with the distribution of population in the Cambridge region with special reference to the bronze age. Dr. T. Ashby will give an account of archaeological investigations carried out in Italy during the last twelve months, as well as of certain supplementary investigations made by himself at the megalithic temple of Hal Tarxien in Malta. Miss Murray also will describe the excavations which she is now carrying on in the same island. Mr. Stanley Casson will give an account of his recent excavations in Macedonia, and discuss their bearing upon certain general problems. This communication, in conjunction with one from Mr. J. Whatmough on inscribed fragments of staghorn from North Italy, of which the inscriptions are in an unknown language, should give rise to fruitful discussion on racial movements in Europe in late prehistoric times. In physical anthropology Prof. W. J. Sollas will discuss comparative craniometric methods, with special reference to Neanderthal Man; and in ethnography the two most important communications will be a description of rock-paintings from New Guinea by Dr. W. M. Strong, and an account of certain peoples of the Congo area by Mr. E. Torday. The latter will deal incidentally with the question of the decay of custom among primitive peoples.

SECTION I (PHYSIOLOGY).—The section of physi-

ology can congratulate itself on an exceptionally good programme. Local effort is well represented, for the first morning session, as well as parts of other sessions, are occupied by papers contributed by Hull members of the medical profession. The meeting will open with a paper by Dr. F. C. Eve, senior physician to the Hull Infirmary, on "Life and Energy: an Interpretation." Dr. T. Ritchie Rodger is to follow with a paper on "The Effect of Loud Noises on the Cochlea," in which he will discuss the consequences of the boiler-making industry in causing damage to the organ of hearing. A demonstration of a model of the cochlea, by Dr. G. Wilkinson of Sheffield, is also of interest in this connexion. The investigation of the movements of the alimentary canal by means of the X-rays will be described and demonstrated by Dr. J. E. Bannen. Prof. A. V. Hill will read a paper on athletics and oxygen supply, in which he will show what a large debt of oxygen becomes due to the body in severe exertion, to be called in during the succeeding period of rest. The presidential address, by Prof. E. P. Cathcart, on the "Efficiency of Man and the Factors which Influence It," will deal with another aspect of muscular work which Prof. Cathcart has studied, in America with Dr. Benedict, and at home in connexion with the energy requirements of recruits. There are two interesting joint discussions with other sections. With the section of physics there is to be a discussion on the application of physical methods to biological investigations, to be opened by Prof. A. V. Hill; while with the section of agriculture there will be a discussion of the popular topic of the vitamins, to be opened by Prof. J. C. Drummond. In this discussion we welcome a paper by Dr. Atherton Seidell of Washington, who has done outstanding work on the isolation of vitamins. The foreign guest of the section, Prof. W. Storm van Leeuwen of Leyden, will contribute two interesting papers on hypersensitiveness, a subject of considerable importance in relation to the causation of asthma, hay fever, and serum sickness. The section is fortunate in securing two eminent physiologists to deliver popular lectures—Mr. J. Barcroft on the expedition which he recently led to Peru for the study of mountain sickness in the Andes, and Prof. W. D. Halliburton, who will lecture on "Our Bones and Teeth." Dr. F. W. Edridge-Green will give two papers on colour vision, Dr. P. M. Tolmie of Hull one on the cytology of the blood, and Dr. J. H. Burn a contribution to the physiology of sweating, in which he shows how certain clinical facts can be explained on physiological lines.

**SECTION J (PSYCHOLOGY).**—The new psychological section of the British Association met for the first time last year at the meeting held at Edinburgh. Judging by the programme announced, it should have an equally successful session this year at Hull. Unfortunately, however, it has already sustained a grave and lamentable loss by the death of Dr. W. H. R. Rivers, the elected president. Dr. C. S. Myers, who has just given up his Cambridge post to become director of the new National Institute of Industrial Psychology, is taking the chair in Dr. Rivers' place, and his presidential address will deal with the influence of Dr. Rivers' work on the development of psychology in Great Britain. The first important feature in the programme will be the opening discussion upon industrial psychology. In this Dr. Myers, Dr. Miles, Mr. J. Seebohm Rowntree, and Mr. Eric Farmer are taking part. The two first speakers will doubtless describe the work proposed, and the work hitherto carried out, by the National Institute, in the establishment of which they have had so prominent a share. Mr. Farmer is reporting an investigation on "Output Curves as Measures of Fatigue"—an inquiry carried out under the In-

dustrial Fatigue Research Board—and Mr. Rowntree is describing the results of some group-tests of intelligence applied to the employees at the big factory at York. Friday morning, September 8, will be devoted to a joint discussion with the Section of Educational Science upon psychoanalysis and the School. In this the chief speakers will be Dr. Kimmins, Dr. Crichton Miller, Prof. Pear and Dr. R. G. Gordon. The other joint discussion will be that held in conjunction with the Anthropological Section on Tuesday morning, September 12, when Prof. J. L. Myers, Prof. A. A. Fleure, and Dr. C. S. Myers are holding a symposium on mental characteristics and race. On the same afternoon there will be a similar symposium on mental deficiency, in which Dr. Auden (the School Medical Officer for Birmingham) and Dr. Shruballs (the Assistant School Medical Officer for London) will both take part.

**SECTION K (BOTANY).**—Under the presidency of Prof. H. H. Dixon, Section K has a very full and varied programme for the Hull meeting. The president's address will deal with "The Transport of Organic Substances in Plants." An interesting feature of the programme will be the joint discussions on photosynthesis (with Section B) and on the present position of Darwinism (with Section D). The discussion on photosynthesis will be opened by Dr. F. F. Blackman with a paper on the biochemical problem of chloroplastic photosynthesis, which will be followed by Profs. Baly and Heilbron with accounts of their recent important researches upon carbon and nitrogen metabolism in green leaves. Contributions to this discussion will also be made by several other botanists and chemists. An animated discussion is expected upon the present position of Darwinism, which will be opened by Dr. J. C. Willis, who will treat of "The Inadequacy of the Theory of Natural Selection as an Explanation of the Facts of Geographical Distribution and Evolution." He will be followed by Mr. Udney Yule, with a paper on "A Mathematical Concept of Evolution based on the Theory of Age, Size, and Space." Mr. C. Tate Regan will then enter the arena, and, it is understood, will attack the Willis-Yule position from the zoological point of view. Other speakers will include Prof. Johannsen (Denmark), Dr. J. T. Cunningham, and Dr. H. Wager. Persons interested in forestry are again linked with Section K as at Edinburgh, and a morning is to be devoted to papers on forestry, the most important of which is one by the Right Hon. Lord Lovat (Vice-President of the section) on the position of British forestry today. The popular lecture is to be given this year by Prof. Dame Helen Gwynne-Vaughan, who will take "Moulds" as her subject. The remainder of the programme is representative of many different branches of botany, including plant physiology, genetics, cytology, mycology, anatomy, and ecology. Thanks to the local botanical committee, a fine excursion programme has been arranged, including visits to Spurn Head, Skipwith and Riccal Commons, and Brantingham Dale. In addition, permission has been given to members interested in forestry to visit Lord Yarborough's woods by the kindness of the owner.

**SECTION L (EDUCATIONAL SCIENCE).**—The proceedings of this section will open at 10 A.M. on Thursday, September 7, with an address on "Educational and School Science" by the president, Sir Richard Gregory. The address will be used to open discussion upon what should be the character and content of school science courses in the general education of all up to about sixteen years of age. Prof. J. Arthur Thomson will be one of the speakers on this subject. After the discussion there will be a paper on advanced instruction in elementary schools by Mr. R. C. Moore.

Lord Haldane had arranged to give an address in the afternoon, but unfortunately he has had to cancel all public engagements for reasons of health. Two important meetings will be held on Friday, September 8. In the morning there will be a joint meeting with the Psychological section for the discussion of psychoanalysis in relation to the school. The opening speakers will be Dr. C. W. Kimmins, Dr. Crichton Miller, Prof. Pear, and Dr. R. G. Gordon. In the afternoon, addresses on Imperial Citizenship will be given by the Rt. Hon. Lord Meston and the Rt. Hon. Sir Joseph Cook (High Commissioner for Australia). Bishop Welldon will also speak. On Monday, September 11, there will be a paper on international students' organisations, by Mr. Iveson

S. Macadam (President of the National Union of Students), and a discussion on English as the basis of national education, at which the speakers will include Mr. G. R. Pocock (Dartmouth College), Prof. Edith Morley, and Dr. F. S. Boas. The morning of Tuesday, September 12, will be devoted to local educational work, and the papers will be on the movement towards individual work in schools, with special reference to experiments in Hull, by Miss F. Sayer; and on the Dalton Plan, by Miss C. T. Cumberbirch. In the afternoon there will be a joint discussion with the engineering section on the effect of reformed methods in teaching mathematics, to be opened by Prof. P. T. Nunn and Mr. R. C. Fawdry (Clifton College).

### The Imperial Cancer Research Fund.

THE executive of the Imperial Cancer Research Fund can look with satisfaction on twenty years of steady progress towards the understanding of the nature of tumours. In the twentieth annual report, lately issued, the director, Dr. J. A. Murray, records once again a tale of sound and solid work in a field which is rather particularly liable to be overrun with hasty and slipshod frontal attacks and premature attempts to find a cure for cancer.

Of chief interest perhaps are Dr. Drew's experiments on the growth of normal and malignant tissues *in vitro*. Observations on the transplantable tumours of mice have shown that malignant tissue has no natural duration of life, the same tumour growing continuously under favourable conditions for a period far longer than the normal life of the animal in which it arises. Similarly, experiments on the continuous culture of normal tissue *in vitro* show, with a certainty which will increase with further lapse of time, that they too may achieve an analogous immortality. The fundamental functional characteristic of tumours is their independence of, and dissociation from, the rest of the body in which they grow. If normal tissues are subjected to the same dissociation by isolation in artificial cultures, they too appear to be capable of continuous life without the intervention of sexual regeneration.

Dr. Drew has now analysed this question of the influence of different tissues on one another to a further point. He finds that epithelial cells when growing in pure culture remain undifferentiated. When connective tissue cells are added to such cultures, differentiation sets in with little delay, squamous epithelium producing keratin in the familiar form of the concentric corpuscles so well known in human epitheliomata and mammary epithelium growing into branching acinous structures.

The form of the cells depends, then, more on where they are than on their origin, and the facts form an interesting commentary on the experimental side on the views of Dr. G. W. Nicholson on heteromorphosis in tumours put forward in his essays in recent numbers of the Guy's Hospital Reports. Dr. Drew has discovered also the curious point that malignant cells quickly make the fluid in which they grow unsuitable for further multiplication, though normal tissue will still grow in it readily. Continuous culture of malignant cells requires more frequent transplantation than do normal tissues, exemplifying the observational fact that human tumours are less resistant than normal tissues to all sorts of harmful influences—infections, poisons such as arsenic, radiation of different kinds, and so forth. They are superior to normal tissues only in their capacity to override the rules governing normal growth differentiation and morphology.

Drs. Cramer Drew and Mottram have continued their studies of vitamin deficiencies. Defect of vitamin A produces characteristically a diminution in the blood platelets, just as absence of vitamin B leads to almost complete disappearance of lymphoid cells. Similar changes in the blood elements may be induced by X-rays and radium. No success was obtained in attempts to influence the growth of transplanted tumours by vitamin deficiencies. In continuation of the production of malignant epithelial tumours by the repeated irritation of the skin by tar and similar substances, Dr. Russell now records the generation of malignant tumours of connective tissue by its subcutaneous administration. He also records further progress in his study of the respiratory exchange of tumours.

### European Fish in New Zealand Waters.

A VERY useful account of the Marine Biological Station and Fish Hatchery at Portobello in New Zealand has been prepared by the Hon. G. M. Thomson and the late Mr. Thos. Anderton, and is published as Bulletin No. 2 of the Board of Science and Art of the Dominion. There is an appreciative note about Mr. Anderton, a man of great practical ability, who began life as a mercantile marine officer and then became a marine zoologist: he organised the Portobello Station with conspicuous success. The work of this institution is remarkable for the very original experiments carried out in connexion with it, having in view the naturalisation of European

fishes and other marine edible animals in New Zealand waters. These attempts are well known in a general way, but it is well to have detailed records of their methods and results.

The main object was to introduce the European herring, turbot, edible crab and lobster. The herring was taken over in the form of large numbers of fertilised ova and the turbot in the form of small immature fishes. Undismayed by unfavourable reports by various ichthyologists, a number of preliminary experiments were made in order to discover whether the rate of development of herring ova could be retarded by the employment of low



temperatures so that the eggs could be carried through the tropics and would hatch at about the end of the journey to New Zealand.

Prof. J. Cossar Ewart and Dr. H. C. Williamson made the preliminary experiments and Mr. Anderton devised the water-cooling and circulating apparatus, which was fitted up in a cold room on an ordinary commercial vessel. As fishery zoologists well know, it is not easy to collect large numbers of healthy, fertilised herring eggs, but this was successfully done at Lowestoft by Mr. Anderton, and the ova were made to adhere to glass plates, which were then transferred to the apparatus on board ship. The water was kept at a temperature a little above 0° C. and was circulated over the eggs. The experiment would have been quite successful but for a breakdown in the tank arrangements of the ship. It has not been repeated, though it is now evident that the method presents no insuperable difficulties. The young turbot and the pregnant edible crabs and lobsters were taken out to New Zealand without any difficulty and were successfully "planted" there.

So far there is no proof, however, that these species have established themselves in their new environment. The ingenuity displayed in these experiments and the eminently practical methods employed are of much interest and well deserve permanent record.

### University and Educational Intelligence.

EDUCATIONAL legislation in America in 1919 and 1920 is reviewed by one of the specialists of the Washington Bureau of Education in Bulletin No. 13 of 1922. Of the many problems connected with education which have been dealt with by the State Legislatures since the war, several are, or have lately been, subjects of controversy in this country. The proportions in which the cost of supporting schools is shared between the general tax-payer and the rate-payer have been changing at the expense of the former throughout the States, "including the South, where the State, as such, is already relatively a very large contributor and where the need is rather for the further development of local educational spirit." In the State of New York the increase in appropriations for schools amounted to over twenty million dollars, which was added for the purpose of raising teachers' salaries. Texas appropriated four million dollars for the same purpose. Many of the States passed salary laws more or less on the lines of the "Burnham scales." Under an Iowa act, for example, a schedule of minima is prescribed, the lowest being 50 dollars a month, while a teacher who has received a degree upon completion of a four-year college course and holds a State certificate must be paid not less than a hundred dollars a month, and after two years of successful experience not less than a hundred and twenty. Teachers' superannuation systems are of recent origin in the United States, very few having been established earlier than the beginning of the present century. Nearly half of the States now have systems established by law for the entire State, and nearly a third have laws for certain cities only. Tendencies in recent pension laws are in general towards a larger participation of public funds in the support of the system, a more thorough application of scientific actuarial data, and more business-like administration. Extensions of the age limits of compulsory education have been effected recently in many States, the upper limit being in many cases raised to sixteen, while the lower limit is commonly seven or eight years.

### Calendar of Industrial Pioneers.

**August 20, 1769. Gabriel Jars died.**—A native of Lyons and born in 1732, Jars acquired a practical knowledge of mining under his father, and after studying at the *École des ponts et chaussées*, made a long tour of inspection of the mines of England, Scotland, Sweden, Holland, Austria, and other countries, the results of his observations appearing in his "*Voyages métallurgiques*" published after his death.

**August 21, 1884. Henry Wimshurst died.**—For many years a shipbuilder at Millwall, Wimshurst was an ardent supporter of Pettit Smith in his endeavours to introduce screw propulsion, and, with the aid of friends, in 1838 he built the *Archimedes*, the vessel which first demonstrated the value of the screw for propelling ships in the open sea, and in 1839 he built the *Novelty*, the first screw steamer to make a commercial voyage.

**August 23, 1836. Louis Marie Henri Navier died.**—A distinguished professor of engineering, known for his mathematical investigations, Navier was an engineer in the Corps des ponts et chaussées, and at the time of his death was professor of analysis and mechanics in the *École Polytechnique*.

**August 24, 1860. Jesse Hartley died.**—The son of the master bridge-builder to the county of York, Hartley succeeded to his father's position, and in 1824 became engineer to the Liverpool docks, in which capacity he planned and executed with complete success the most extensive dock works in the world.

**August 25, 1819. James Watt died.**—Acknowledged to be the greatest engineer of modern times, Watt made his great discovery of the separate condenser in 1765, while engaged on the repair of a model of a Newcomen atmospheric steam engine for Glasgow University. This improvement in the steam engine was followed by his patents of 1769, 1781, 1782, and 1784, which collectively transformed a rude and imperfect contrivance into an efficient and powerful machine, providing the miner with his pump, the smelter with his blast, and the weaver with his power-house. From his early boyhood Watt was given to scientific pursuits, and all his work was the result of the application of scientific principles to practical problems. Born in Greenock, he became instrument maker to Glasgow University, and after some years of civil engineering, in 1775 entered into partnership with Matthew Boulton, the founder of the Soho Manufactory. Watt died at Heathfield House, close by Soho, and was buried in Handsworth Church.

**August 25, 1862. James John Berkley died.**—Trained under Bidder and Robert Stephenson, Berkley in 1849 was appointed Chief Resident Engineer of the Great Indian Peninsular Railway, and as such projected and carried through with the highest skill the line of railway from Bombay to Calcutta.

**August 26, 1845. Philippe Henri de Girard died.**—Famous as a chemist, a mechanic, and technologist, Girard was born on February 1, 1775, and after the French Revolution had soda factories at Marseilles and Paris. The offer by Napoleon in 1810 of a prize of a million francs for flax machinery led Girard to devise new machinery and establish flax mills, but he received no prize. After the Restoration he lived mainly in Austria and Poland, promoting steam navigation on the Danube, and carrying out extensive operations in manufactures, metallurgy, and practical engineering at Warsaw.

E. C. S.

## Societies and Academies.

## PARIS.

Academy of Sciences, July 17.—M. Emile Bertin in the chair.—H. Deslandres and V. Burson: Researches on the atmosphere of the stars. Properties of stars which have the same radiations and the same chromospheric layers as the sun: a list of twelve stars is given, all of which show bright lines: eleven of these are yellow stars of types G and K (Harvard classification), one only is of the M<sub>2</sub> type. These stars possess chromospheres relatively more luminous and more important than those of the sun.—Charles Moureu and Charles Dufraisse: Auto-oxidation. Anti-oxygenic power. Various phenomena relating to anti-oxygenic action. It has been shown in an earlier communication that certain substances, of which hydroquinone is the type, can prevent oxidation. The reaction between acrolein and oxygen has been studied quantitatively, when the proportion of hydroquinone present has been varied between  $\frac{1}{10}$ th and  $\frac{1}{1000}$ th of the acrolein present; and the results given in graphical form. Various phenols are classified according to their power of retarding oxidation ("anti-oxygenic power"). A summary is given of earlier work bearing on the subject.—Maurice Leblanc: Lamps with three electrodes, anode, cathode, and intermediate grid where the current is carried by ions, and their applications. It is shown how these lamps can be used to transform a continuous current in an alternating current of high frequency or to transform high-frequency currents into alternating currents of low frequency.—Jules Andrade: Mechanical determinism and the notion of the medium: pseudo-elliptic orbits and circular orbits.—Paul Vuillemin: The legitimacy of the genera Laverania and Nocardia.—Jules Baillaud: The co-ordinates of the galactic pole, deduced from the distribution of the stars in the zone of the Paris astrophotographic catalogue.—M. Bedeau: The determination of the specific inductive capacity of mercury vapour. The measurements were made at a temperature of 400° C., under atmospheric pressure, utilising the method described in an earlier communication for air. Mercury vapour shows none of the anomalies proved for steam, ammonia, etc., and its specific inductive capacity is in agreement with  $1.00074$  deduced from Maxwell's formula.—Jean G. Popesco: The variation of the surface tension of mercury in gases. Employing a kinematographic method, the variation of the surface tension of mercury with time of exposure to various gases has been measured. Results are given for air, ammonia, sulphur dioxide, hydrogen, carbon dioxide, and nitrogen. In all cases there is a rapid fall in the surface tension, and the variation is of the same order of magnitude in all the gases, about 5 per cent. reduction in 10 seconds, increasing to about 24 per cent. after 24 hours' exposure.—M. Lindsay: The limits of the L absorption of elements Ba, Cs, I, Te, Sb.—R. de Malleman: Rotatory polarisation and molecular orientation.—Pierre Lambert and A. Andant: An arrangement for depositing films of metal on large surfaces by cathodic projection. The use of greased ground joints is avoided by using a double bell jar. Both jars are exhausted down to about 10 mm., and the evacuation of the inner jar, containing the cathode and object to be silvered, is completed by a Gaede pump.—Ch. Fabry and H. Buisson: The curve of the distribution of energy in the ultraviolet part of the solar spectrum.—M. Duffieux: The mass of the particles which give the spectrum of carbon monoxide. The bands are emitted by particles the masses of which are in the ratio of

16:12, and hence are not due to the molecule CO but to its decomposition products, the free atoms of carbon and oxygen.—Paul Mondain-Monval: The preparation of ammonium chloride at a low temperature.—A. Ch. Vournazos: Mixed complex anti-iodobromides. Several complex salts have been isolated, of which the sodium salt Na(SbBrI<sub>3</sub>) may be taken as the type.—L. J. Simon: The chromic oxidation of the homologues of acetic acid. A comparison of the oxidising effects of the two mixtures, sulphuric acid, chromic acid, and sulphuric acid, silver chromate upon eleven fatty acids. These acids are only partially converted into carbon dioxide and water by the chromic acid mixture, but are completely burnt when silver chromate replaces chromic acid.—Maurice François and Louis Gaston Blanc: A method of preparing the iodo-mercurates of the alkaloids in a crystallised condition.—A. Wahl and R. Lantz: The 2-oxy-1-arylnaphthylamines.—Louis Longchambon: The rotatory power of crystals and molecular rotatory power.—René Abrard: The presence of *Nimmulites variolaris* in the Cresnes, Marines, and Ruel sands and their significance.—P. Lavialle and J. Delacroix: The wall of the pistil and fruit in the genus Euphorbia.—J. Athanasiu and L. Bull: The registration of the longitudinal vibrations of muscle during voluntary contraction.—Pierre Girard, W. Mestrezat, and Li-Shou-Houa: A physical view of the selective permeability of living cells for different ions.—Mlle. Marthe Giroud, Gaston Giroud, and L. Parès: Experimental researches on the genesis of the haemolysis crisis of intensive irradiations.—L. Panisset, J. Verge, and E. Grasset: The fixation-reaction in the diagnosis of tuberculosis in cattle. The Bordet-Gengou method may be applied to the diagnosis of tuberculosis of milch cows.—M. Denucé: The treatment of congenital dislocation of the hip.

## Official Publications Received.

Abisko Naturvetenskapliga Station. Observations Météorologiques à Abisko. Situé par 68°30' Lat. Nord et par 18°15' Long. Est. By Bruno Rolf. En 1913. Pp. xvi+76. En 1918. Pp. ii+74. En 1919. Pp. ii+75. En 1920. Pp. iii+76. (Uppsala: Almqvist and Wiksells Boktryckeri A.-B.)

Department of the Interior: Bureau of Education. Bulletin, 1921, No. 27: Training for Foreign Service. Compiled by Glen Levin Swiggett. Pp. vi+154. (Washington: Government Printing Office.) 15 cents.

Memoirs of the Bernice Pauahi Bishop Museum. Vol. 8, No. 3: The Grasses of Hawaii. By A. S. Hitchcock. Pp. 132+5 plates. Vol. 8, No. 4: Bayard Dominican Expedition, Publication No. 2: A Contribution to Tongan Somatology. By Louis R. Sullivan. Pp. 30+4 plates. (Honolulu: Bishop Museum Press.)

Occasional Papers of the Bernice Pauahi Bishop Museum of Polynesian Ethnology and Natural History. Vol. 7, No. 12: Notes on Hawaiian Zonitidae and Succineidae. By C. Montague Cooke, Jr. Pp. 17+2 plates. Vol. 7, No. 13: Stonatopoda in the Bernice P. Bishop Museum. By Chas. H. Edmondson. Pp. 24. Vol. 7, No. 14: Detraptera and Orthoptera of Hawaii. By Morgan Hebard. Pp. 76+2 plates. Vol. 8, No. 2: Hawaiian Dromiidae. By Chas. H. Edmondson. Pp. 10+2 plates. Vol. 8, No. 3: Proverbial Sayings of the Tongans. By E. E. V. Collocott and John Haven. Pp. 118. Vol. 8, No. 5: Report of the Director for 1921. Pp. 39. (Honolulu: Bishop Museum Press.)

Union of South Africa: Department of Agriculture. Bulletin No. 2: Pear Scab in the Western Province. Experiments and Facts relating to its Control. By V. A. Punterill. Pp. 31. (Pretoria: Government Printing and Stationery Office.) 3d.

Department of Statistics, India. Agricultural Statistics of India, 1919-20. Vol. 2: Area, Classification of Area, Area under Irrigation, Area under Crops, Live-stock, and Land Revenue Assessment in certain Indian States. Pp. iv+v+192. (Calcutta: Government Printing Office.) 1-8 rupees.

Bihang till Meteorologiska Iakttagelser i Sverige, Band 60, 1918: Termosynkroner och Termoskroner på den skandinaviska Halvön. By H. E. Hamberg. Pp. 39+15 plates. (Stockholm: Almqvist and Wiksells Boktryckeri A.-B.)

U. S. Department of Agriculture: Weather Bureau. Monthly Weather Report. Supplement No. 20: An Aerological Survey of the United States Part 1: Results of Observations by Means of Kites. By Willis Ray Greig. Pp. iv+78. (Washington: Government Printing Office.)

# NATURE

A WEEKLY ILLUSTRATED JOURNAL OF SCIENCE.

*"To the solid ground  
Of Nature trusts the mind which builds for aye."*—WORDSWORTH.

No. 2756, VOL. 110

SATURDAY, AUGUST 26, 1922

[PRICE ONE SHILLING

Registered as a Newspaper at the General Post Office.]

[All Rights Reserved.]

## OPTICAL PROJECTION APPARATUS

for all classes of  
**EDUCATIONAL WORK.**

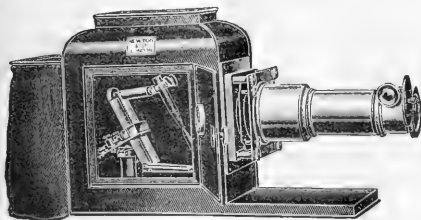

*Catalogue on application.*

**NEWTON & CO.,**

*Opticians to H.M. the King.*

72 WIGMORE STREET, LONDON, W.1.

## REYNOLDS & BRANSON, Ltd.

Chemical and Scientific Instrument Makers to His Majesty's  
Government (Home and Overseas Dominions).

LABORATORY FURNISHERS and MANUFACTURING CHEMISTS

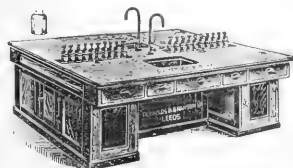

**WORKS AND OTHER  
LABORATORIES**  
equipped  
with Benches, Fume  
Chambers, Apparatus,  
Balances,  
Chemicals, etc.  
Designs and quotations  
submitted on application

BRITISH-MADE Glass, Porcelain,  
Nickel Ware, and Filter Papers.

Apparatus in Glass, Metal, or Wood made  
to customers' own Designs.

CATALOGUES POST FREE.

*Enquiries for Technical Chemicals in quantity solicited.*

**14 COMMERCIAL STREET, LEEDS.**



**BAIRD & TATLOCK, LONDON LTD.**

SCIENTIFIC INSTRUMENT MANUFACTURERS  
and LABORATORY FURNISHERS.

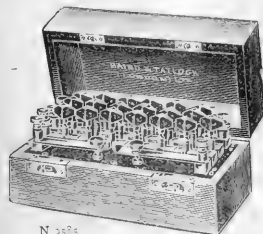

N 5088  
RESISTANCE BOX

Physical  
Apparatus  
for  
Schools  
and  
Colleges.

**14 15, CROSS STREET, BAYTON GARDEN, LONDON, E.C.1.**

## HIGH RANGE THERMOMETERS

Of Guaranteed Accuracy.

NATIONAL PHYSICAL LABORATORY

Certificate of N. & Z. Thermometer No. D 10520.

Reading.	Correction.
212 F.	0 F.
300	0
400	0
500	-1
600	-1
700	0
805	0

Above is a Copy of Certificate of a Thermometer  
recently verified.

**NEGRETTI & ZAMBRA**  
38, HOLBORN VIADUCT, E.C.1.  
LONDON.

## UNIVERSITY OF BIRMINGHAM.

### FACULTIES.

- Science:** Subjects—Mathematics, Physics, Chemistry, Zoology, Botany, Geology, Engineering (Mechanical, Civil, Electrical), Metallurgy, Mining (Coal, Metal, Petroleum), Bio-Chemistry of Fermentation.
- Arts:** Subjects—Latin, Greek, English, French, German, Italian, Spanish, Russian, Philology, History, Music.
- Medicine:** All subjects leading to Degrees and Diplomas in Medicine and Dentistry.
- Commerce:** Subjects leading to Degrees in Commerce.

Department of Training for Teachers.  
Department of Social Study.  
Department of Malting and Brewing.

### THE SESSION 1922-23 COMMENCES ON OCTOBER 2, 1922.

### ALL COURSES AND DEGREES ARE OPEN TO BOTH MEN AND WOMEN STUDENTS.

In the Medical School Courses of Instruction are arranged to meet the requirements of other Universities and Licensing Bodies.

Graduates, or persons who have passed Degree Examinations of other Universities, may, after one year's study or research, take a Master's Degree.

**Separate Syllabuses** with full information as to Lecture and Laboratory Courses, Fees, Regulations for Degrees, Diplomas, &c., Exhibitions, and Scholarships, are published as follows:

1. Faculty of Science.
2. Faculty of Arts.
3. Faculty of Medicine.
4. Faculty of Commerce.
5. Department of Social Study.
6. Department of Biology and Chemistry of Fermentation.
7. Exhibitions, Scholarships, &c.,

and will be sent on application to the REGISTRAR.

## UNIVERSITY COLLEGE OF SWANSEA.

### (A CONSTITUENT COLLEGE OF THE UNIVERSITY OF WALES.)

#### Applied Science Departments.

##### METALLURGY.

Professor: C. A. EDWARDS, D.Sc. (Manchester).  
Lecturer: H. I. COE, M.Sc. (Wales and Birmingham).  
Assistant-Lecturers: A. L. NORBURY, M.Sc. (Manchester), L. B. FEARL, B.Sc., A.R.S.M.

##### ENGINEERING.

Professor: FREDERIC BACON, M.A. (Cantab.), A.M.Inst.C.E., M.I.Mech.E., M.I.E.E.  
Lecturer in Electrical Engineering: R. G. ISAACS, B.Sc. (Lond.) A.M.I.E.E.  
Lecturer in Civil Engineering: To be appointed.  
Demonstrator: J. SELWYN CASWELL.

The College offers a number of exceptional advantages to students who aim at entering upon professional careers in Metallurgy or Engineering. It is situated in the heart of an industrial area, which includes a large number of Works of very varied character, and presents an unrivalled variety of metallurgical practice. The manufacturers of the district, who contribute largely to the support of the College, give the staff and the students of the Applied Science Departments every access to the Works, and the Managers, Engineers, and Technical Officials co-operate with the Staff of the College in making visits to Works of practical educational value to the Students.

Courses of study are provided (1) for the B.Sc. Degree of the University of Wales in (a) Metallurgy, (b) Civil Engineering, (c) Mechanical Engineering, (d) Electrical Engineering; and (2) for Diplomas of the College in (a) Metallurgy, (b) Civil Engineering, (c) Mechanical Engineering, (d) Electrical Engineering.

Persons who are not desirous of studying for degrees or diplomas may attend selected College Classes, provided they satisfy the authorities of the College that they are qualified to benefit by such classes.

Entrance Scholarships will be offered for competition in September 1922. Particulars concerning admission to the College, and of the Entrance Scholarships, may be obtained from the undersigned.

EDWIN DREW, Registrar.

University Park,  
Singleton Park, Swansea.

## CHELSEA POLYTECHNIC,

CHELSEA, S.W.3.

Session begins September 25, 1922.

Day and Evening Courses in Science under Recognised Teachers of London University.

### I. INDUSTRIAL CHEMISTRY DEPARTMENT.

Technical Courses in Analytical and Manufacturing Chemistry, Pharmacy, Food and Drugs, A.I.C. Courses, Metallurgy, Assaying, Foundry Work, Research.

### II. INDUSTRIAL PHYSICS DEPARTMENT.

Practical work in General Physics, Applications to Industries, Metrology, Calorimetry, Illumination, Acoustics, Electrical Measurement, Research.

### III. BIOLOGICAL AND GEOLOGICAL DEPARTMENT.

Courses for B.Sc., etc., in Botany, Geology, Mineralogy, Zoology, Special Courses in Bio-chemistry, Bio-physics, Bacteriology, Physiology, Hygiene, Entomology, Plant Pathology. Course for Tropical Planters, Research.

SIDNEY SKINNER, M.A.,  
Principal.

Telephone: Kensington 899.

## BATTERSEA POLYTECHNIC,

LONDON, S.W.11.

Principal—ROBERT H. PICKARD, D.Sc., F.R.S.

Day Technical College in preparation for Polytechnic Diplomas in Mechanical, Civil and Constructional, and Electrical Engineering, Chemistry, Mathematics, and Physics, and for B.Sc., and B.Sc. (Eng.) Pass and Honours Degrees of the University of London.

Training College of Domestic Science in preparation for Teachers' Diplomas in Cookery, Laundrywork, Housewifery, Needlework, Dress-making, and Millinery.

Department of Hygiene and Public Health for the training of Sanitary Inspectors, Health Visitors, Welfare Workers, etc.  
School of Art and Crafts for training in Drawing and Design, Fashion Plate Drawing, Applied Art, etc.

Hostels for Women Students.

Evening Courses in preparation for University of London Degrees in Science, Engineering, and Music, and in Mechanical and Electrical Engineering, Mathematics, Physics, Chemistry, Art and Crafts, Civil Service Subjects, Domestic Science, Music and Physical Training.

Next session begins on Tuesday September 19, 1922.

Full particulars of all classes on application to the Principal.

## THE UNIVERSITY OF LIVERPOOL.

### SESSION 1922-23.

The Autumn Term begins on October 5. Prospectuses and full particulars of the following may be obtained free (with the exception of the Calendar, price 2s. 6d., post free 3s.) on application to the REGISTRAR:

JOINT BOARD MATRICULATION EXAMINATION.  
AWARD OF HIGHER SCHOOL CERTIFICATES.

AWARD OF SCHOOL CERTIFICATES.

FACULTIES OF ARTS, SCIENCE, MEDICINE, LAW, AND ENGINEERING.

SCHOOL OF ARCHITECTURE.

DEPARTMENT OF CIVIC DESIGN.

DEPARTMENT OF COMMERCE.

INSTITUTE OF ARCHÆOLOGY.

DEPARTMENT OF EDUCATION.

UNIVERSITY EXTENSION BOARD.

SCHOOL OF SOCIAL STUDIES.

SCHOOL OF LOCAL HISTORY AND RECORDS.

SCHOOL OF RUSSIAN STUDIES.

DEPARTMENT OF PUBLIC HEALTH.

SCHOOL OF TROPICAL MEDICINE.

SCHOOL OF VETERINARY SCIENCE.

SCHOOL OF DENTAL SURGERY.

DOCTORATE IN PHILOSOPHY.

FELLOWSHIPS, SCHOLARSHIPS, STUDENTSHIPS, EXHIBITIONS, SPECIAL GRANTS AND PRIZES.

HALLS OF RESIDENCE.

UNIVERSITY CALENDAR.

## UNIVERSITY COLLEGE,

### NOTTINGHAM.

SESSION 1922-23 BEGINS OCTOBER 3.

Students are prepared for the PASS AND HONOURS DEGREES of the University of London, for the examinations of the Institutes of Chemistry and Physics, for Diplomas in Commerce, Geography, Social Study, Adult Education, Engineering, Mining and Textiles, and for the examinations of the Pharmaceutical Society.

Post Graduate and Research Work is carried out in all Departments of the College.

Prospectuses giving particulars of all Degree and Diploma courses, fees and residence, will be forwarded free on application to the REGISTRAR.



SATURDAY, AUGUST 26, 1922.

## CONTENTS.

	PAGE
The New Smoke Abatement Bill. By Prof. J. B. Cohen, F.R.S. . . . .	269
The Earth's Structure and its Evolution . . . . .	270
Textile Technology . . . . .	272
Highway Engineering . . . . .	272
Radio-Communication . . . . .	273
Plant Morphology and Physiology . . . . .	274
The Development of Vertebrates . . . . .	275
Our Bookshelf . . . . .	275
<b>Letters to the Editor:—</b>	
The Influence of Science.—Sir Oliver Lodge, F.R.S. . . . .	277
Action of Cutting Tools. (Illustrated.)—A. Mallock, F.R.S. . . . .	277
Rudbeckia and Aquilegia. (Illustrated.)—Prof. T. D. A. Cockerell . . . . .	278
The Rat and its Repression.—The Earl of Denbigh . . . . .	278
The Spectrum of Helium in the Extreme Ultra-Violet. —Prof. Theodore Lyman . . . . .	278
Transcription of Russian Names.—Cecil A. Hoare . . . . .	279
Sense of Smell in Birds.—Prof. Alexander Meek . . . . .	279
A Coincidence in Values.—L. M. Stewart . . . . .	279
The Evolution of Consciousness.—A. Wyatt Tilby; The Reviewer . . . . .	279
Transparency of Liquids and Colour of the Sea.—Prof. C. V. Raman . . . . .	280
Telescopic Observation of Atmospheric Turbulence.—Catharine O. Stevens . . . . .	280
Hesperopithecus, the Anthropoid Primate of Western Nebraska. (Illustrated.) By Prof. Henry Fairfield Osborn . . . . .	281
Science in Egypt. By Col. H. G. Lyons, F.R.S. . . . .	283
Gelatin. By Dr. T. Slater Price . . . . .	286
Current Topics and Events . . . . .	288
Our Astronomical Column . . . . .	290
Research Items . . . . .	291
The Glasgow Meeting of the British Medical Association . . . . .	293
Broadcasting in America . . . . .	294
Third International Congress of the History of Medicine . . . . .	296
The Research Association of British Rubber and Tyre Manufacturers . . . . .	297
University and Educational Intelligence . . . . .	297
Calendar of Industrial Pioneers . . . . .	298
Societies and Academies . . . . .	299
Official Publications Received . . . . .	300

Editorial and Publishing Offices:

MACMILLAN &amp; CO., LTD.,

ST. MARTIN'S STREET, LONDON, W.C.2.

Advertisements and business letters should be addressed to the Publishers.

Editorial communications to the Editor.

Telegraphic Address: PHUSIS, LONDON.

Telephone Number: GERRARD 8830.

NO. 2756, VOL. 110]

## The New Smoke Abatement Bill.

THE new Government bill to prevent the pollution of the atmosphere by smoke again raises the vexed question of the best means of accomplishing this highly desirable result. That the bill, which merely modifies the existing Act of 1875, will leave matters very much as they are, is, however, the considered opinion of those who framed the recommendations of the Departmental Smoke Abatement Committee appointed by the Ministry of Health.

Two years ago an interim report on the prevention of domestic smoke was prepared at the pressing request of the Minister of Health in view of the large housing schemes in contemplation, only to lie dormant in the department.

It is perhaps not sufficiently realised how much of the dirt and damage in our large industrial centres arises from the domestic hearth. In spite of pious opinions to the contrary, it has been established, from carefully ascertained facts, by two independent observers, that of the 2½ million tons of soot turned into the atmosphere something like four-fifths is emitted from domestic chimneys. But that is not all. This incompletely burnt material, formed to some extent by a process of destructive distillation, such as takes place in gas retorts, is charged with tar, whereby it clings to every object with which it comes into contact. Moreover, the tarry soot is strongly acid with sulphuric acid, and its presence on the mortar and masonry of buildings soon shows itself by their gradual disintegration. The evidence of Sir Frank Baines, the head of H.M. Board of Works, was convincing in this respect, and his specimens and photographs exhibited during the inquiry illustrated in a striking manner the conversion of the calcium carbonate (which cement the siliceous particles of the original stone) into the soluble calcium sulphate and the subsequent crumbling of the surface.

Furnace smoke, on the other hand, owing to its higher temperature of combustion, contains a negligible amount of tar; but consists of fine cinder and grit discharged mechanically by the draught. It is true that it darkens the atmosphere, but it does not adhere to any extent, and much of it is washed away by rain.

To return then to domestic smoke. In a brochure recently published and entitled "The Smokeless City,"<sup>1</sup> Mr. E. D. Simon, a member of the Government Committee and present Lord Mayor of Manchester, and Miss Marion Fitzgerald, his collaborator, have put together the principal facts relating to domestic heating and domestic smoke. The information is drawn partly from the evidence of witnesses who appeared before the committee, partly from the reports of Mr. A. H.

<sup>1</sup> "The Smokeless City," by E. D. Simon and Marion Fitzgerald. Pp. xi+82. London: Longmans, Green and Co., 1922. 1s. 6d.

Barker and Dr. Margaret Fishenden on the efficiency of various forms of grates and kitchen-ranges (already reviewed in these columns), and partly on statistics collected by the Manchester Air Pollution Advisory Board (of which Mr. Simon is chairman) on the cost of washing, a sum estimated at 250,000*l.* a year. The subject is introduced in a preface by Lord Newton, who acted as chairman of the Departmental Committee, and has given time and thought and a sustained and disinterested enthusiasm not often associated in the minds of most people with members of the Upper House. He has even travelled abroad with the sole object of learning how smoke was successfully controlled or prevented in foreign cities.

It is hoped that Lord Newton's pungent remarks on governments—parliamentary and municipal—may be read in the right quarter. He says: "The battle . . . against industrial smoke may be said to have been won in principle, but it is scarcely necessary to warn enthusiasts that there are many parliamentary dangers to be overcome, and that governments are not as a rule particularly zealous in forcing through bills of a non-vote-catching nature."

If the object of the authors was to make out a case against domestic smoke by demonstrating in clear and incisive language, backed by carefully ascertained statistics, its wastefulness and uselessness and the damage it entails, which may be reckoned in millions of pounds annually, the little volume before us may be said to have more than accomplished its purpose. It is now for the public to read the case presented by the authors, take it to heart, and put the conclusions to practical use. The authors have not restricted their remarks to destructive criticism of present methods and appliances for heating and cooking. They have shown a better way. Though they condemn, as all witnesses condemned, the old-fashioned open range, they have described and illustrated modern ranges and discussed their efficiency for varied requirements. They explain in simple language the comparative value of coal, coke, and semi-coke (low-temperature coke) and the relative cost of gas and coal. The book does not profess to be a scientific treatise, and a good deal of recent research on the use of gas for cooking and on the subject of ventilation has been overlooked; but this is no drawback. It is intended for householders, builders, and architects, to whom an appeal based on scientific principles would be incomprehensible and almost certainly unread.

As the new bill excludes all domestic fireplaces and largely ignores the recommendations of the Departmental Committee in regard to new housing construction, it is well that the authors of "The Smokeless City" have saved from the eternal silence of Ministerial

pigeon-holes the accumulated and valuable evidence of so many expert witnesses.

Leaving then the subject of domestic smoke, we may consider for a moment the improvements and defects in the new bill. The amendments are few; the qualification of the indefinite term "black" is omitted, and the expression "smoke" includes soot, ash, and grit; the maximum penalty is raised from 5*l.* to 50*l.*, and the person summoned under the Act must show in his defence that he has used "the best practicable means." On the other hand, there is no reference to the supervision of heating arrangements in new private dwellings but only in public buildings; there is no attempt to standardise the system of inspection of factory chimneys, strongly advocated by the representative of the Sanitary Inspectors' Association; no clear definition of the powers of the central authority; no combination of large areas under the County or Borough Councils; no inclusion of new processes emitting noxious vapours; no provision for competent scientific advisors and supervisors appointed by the Ministry of Health to control and report—in short, the position remains very much *in statu quo*, and the prevention of smoke in industrial areas still remains in the incompetent hands of the local authority, without pressure from the central authority.

The only hope for salvation lies in the energetic action of a disinterested sanitary committee and its medical officer. As the two are linked together, and the smoke inspector harnessed to them, and as members of the sanitary committee are usually interested in manufacture and factory chimneys, the prospect of amelioration is not bright. But if such a disinterested sanitary committee, intent on the purification of its atmosphere, existed, it would reduce boiler smoke to a negligible amount (and the greater part of the factory smoke comes from boilers); it would have a building to exhibit the best appliances for domestic heating and cooking; afford details of the cost of installation and efficiency; it would promote classes for stokers, and appoint an expert, scientifically trained, and well-paid inspector. Such an ideal committee would within a short period render the atmosphere comparable with that of the clean industrial centres of France or Germany.

J. B. COHEN.

### The Earth's Structure and its Evolution.

*Earth Evolution and its Facial Expression.* By Prof. W. H. Hobbs. Pp. xviii+178. (New York: The Macmillan Co.; London: Macmillan and Co., Ltd., 1922.) 15s. net.

THIS volume is intended to present to the non-technical reader the author's conclusions on the form and structure of the earth's crust. The

contents may be summarised as follows. The first chapter deals with some theories of world formation, Laplace's nebular hypothesis being a special object of attack. The second chapter discusses the nature of the earth's interior, after which four chapters relate to the facts and problems connected with volcanic lava. A broader viewpoint is returned to in chapter 7, which treats of the changes of figure through which the earth has passed; this subject is further developed in the following five chapters, the titles of which refer to the present regions of rapid change, the contrasted aspects of the earth's face, the migrational movements of the earth's surface, the patterns of the "facial wrinkles," and the design of the fracture marquetry. The bearing of the composition of lavas on the question of earth physiognomy is then dealt with, and the final (fourteenth) chapter again reviews the theories of the earth. The author gives a list of references at the end of each chapter to works and papers on the subject of the chapter, but no general index of names or subjects is provided, an omission which should be supplied if a second edition is called for.

Despite the somewhat terrifying vocabulary of the geologist, the book contrives to be interesting, and one of its most commendable features is its wealth of illustration, by diagrams, maps, and photographs. The discussion is of a less broad and comprehensive character than the title would lead one to expect, the balance of the book being rather upset by the prominence given to the vulcanological topics in which the author is specially interested. In themselves, however, these chapters contain some of the most novel and interesting parts of the book.

A more serious criticism than that of the title is that the author makes no mention of much important recent work bearing on his subject, as, for example, when dealing with general theories of earth formation, where one is surprised to find nothing about Jeans's cosmogonic researches. The author is particularly concerned to overthrow the notion, based on observations of volcanic lava, that the earth's interior is molten, only the crust being solid. This view has been generally abandoned by geophysicists, on the ground of seismological and other evidence which the author describes. It has, however, long been historically connected with Laplace's nebular hypothesis, though the latter is of much later date, and the two theories are not necessarily bound up together.

The author gives much prominence to Chamberlin's arguments against Laplace's theory, and regards them as destroying the last support of the hypothesis of a molten interior, and as necessitating a fundamental revision of geological theories. Nevertheless, strong as are Chamberlin's arguments—based on considera-

tions of angular momentum—they have not convinced so great an authority on cosmogony as Jeans that Laplace's nebular theory must be finally condemned, though Jeans has propounded a modified form of the theory to explain the origin of the solar system, which is of a very special type among celestial objects; in this theory the planets are supposed to have been separated from the sun, when the latter was much more diffused than now, by the passage of another star at a distance comparable with the sun's diameter at the time. This theory thus preserves the feature of Laplace's hypothesis which seems specially in disfavour with the author, viz. that the earth has cooled down from a diffuse gaseous state. The author himself advocates the planetesimal hypothesis, *i.e.* that the earth originated as a solid body by the aggregation of meteoritic material. However great the claims of this view may be regarded, our present knowledge, or rather ignorance, of the effect of pressure upon hot bodies certainly does not permit us to preclude the other view, that the interior of a large gaseous body might become solid under the influence of the pressure of the upper layers, before or at the same time as the formation of a solid crust.

Another outstanding omission to refer to recent work bearing on the subject relates to Wegener's theory of moving continental masses, now so much discussed by continental geologists. By many interesting diagrams the author shows the situation of the regions of present rapid change and great folding, and discusses Suess's theory that this folding is in general the result of overthrust of one land mass over another. Professor Hobbs's view is that mountains are raised as a result of underthrusts going out from areas of subsidence, generally the ocean areas. These thrusts are supposed due to shrinkage of the strata under the oceans, though no attempt is made to put the hypothesis on a quantitative basis. This, however, is perhaps scarcely feasible as yet, and Wegener's theory, which attributes the thrusts to the resistance of the heavier substrata to the motion of the land masses as wholes, has likewise many points of difficulty about it.

The author's theory of the origin of pockets of molten lava is one of the most interesting parts of the book. The rigidity of the earth is maintained under conditions of internal temperature which are sufficiently high, even relatively near the surface, for at least the aqueous fusion of rock. This rigidity is due to compression by the overlying load, which greatly raises the fusion point. It would therefore seem as if molten matter could exist only in places where the weight of the upper layers has been wholly or partly removed. This is supposed to occur by the folding of

strong upper layers of rock into domed or arched forms, relieving the pressure beneath, at least for a time. This view differs widely from the one commonly held, viz. that the underground chambers of lava represent intrusions through the strata on which they rest, and that the pressure of the lava has itself elevated the roof of the chamber. The author ably supports his thesis by many different lines of evidence.

### Textile Technology.

*Textiles.* By Prof. A. F. Barker. With chapters on The Mercerized and Artificial Fibres, and The Dyeing of Textile Materials, by W. M. Gardner; Silk Throwing and Spinning, by R. Snow; The Cotton Industry, by W. H. Cook; The Linen Industry, by F. Bradbury. (Westminster Series.) Revised edition. Pp. xii+386. (London: Constable and Co., Ltd., 1922.) 15s.

OF the great trinity of human life's essential needs—food, shelter, and clothing—practically all the articles of clothing, as well as a considerable number of articles for improving the shelter, are derived from textiles. The provision of these and other articles has led to the development of the great textile industries. These industries together form the only serious rival to agriculture for chief place among the industries of the United Kingdom, while they rank supreme in their contribution to the country's exports, of which no less than some 40 per cent. are textiles.

It might be expected, therefore, that a large number of people would be interested either as producers or consumers in such a work as the present, which aims at giving in brief compass an outline of the textile industries in their historical, technical, industrial, and commercial aspects. The book opens with an historical introduction; there follow descriptions of the raw materials and their production, and of the principles and processes of spinning, weaving, designing, and finishing. Later chapters deal with the separate industries in turn, namely, the woollen, worsted, cotton, silk, linen, dress goods, etc., and the carpet industries. On the whole the purpose of the book is successfully achieved. The author rightly emphasises the fact that it is the article finally produced which determines the raw material employed and the processes through which this passes. It is for this reason that he deals first with the general principles of spinning and then with the various preparatory processes, which were developed later chronologically for the purpose of presenting the raw material to the spinning machines in a convenient form. The chapter on spinning, in which are described the modern machines and their relation to the old methods, is the best chapter in the book;

the account of the preparatory processes is somewhat scanty, rather disjointed, and occasionally inaccurate. Improvements might be made in certain other directions. Thus, the descriptions of machines sometimes suffer from the absence of explanation of some of the technical terms used; while the replacement of a number of the illustrative photographs by line drawings would add considerably to the value of the book.

It is to be regretted that there is no uniformity of plan in dealing with the separate industries; each special contributor writes from his own particular point of view, with the result that a recasting of their work would be necessary to preserve the unity of the whole. None of these special chapters compares favourably with Prof. Barker's own contributions in general treatment and the selection of material; and in too many instances the statistics and other information, having remained unchanged from the 1910 edition, are now so out-of-date as to be misleading.

In spite of its deficiencies, however, this work remains probably the best in English affording a general introduction to the study of textile technology, and as such it is to be commended.

### Highway Engineering.

*Les Chaussées modernes.* Par Prof. P. Le Gavrian. (Encyclopédie du Génie Civil et des Travaux Publics.) Pp. 431. (Paris: J.-B. Baillière et Fils, 1922.) 40 francs.

THE publication of this text-book marks another step forward in the evolution of one of the most recent developments of engineering and is therefore to be welcomed. Road engineering in its modern form may be said to be contemporaneous with the motor car, the advent of which has again brought a large portion of the national transport on to the roads after an eclipse which lasted from the decline of the stage coach, or even the Roman period, until the introduction of the internal-combustion engine for road vehicles.

The problem of constructing roads to suit modern traffic has probably been best met in Great Britain, but the task fell to busy men, the engineers to the local government authorities, who have had many other pressing and difficult problems to deal with during the same time. Consequently, the practice which has been developed, although well described in the periodical literature, has not been codified or reduced to the form of text-books, although two small publications by Mr. H. P. Boulnois and Mr. F. Wood have to a certain extent met the want.

France has, however, already established a Chair of Highway Engineering, the first occupant of which is



the author of this book, while the project is still under discussion in this country. The chair being established, the need of a text-book has been immediately felt and M. Gavrian has met the want by his excellent book.

The first point that strikes one is that the author does not assume previous knowledge of the subject but begins by a discussion of the conditions to be satisfied and the materials which are available, but it is obvious that he expects the student to have a working acquaintance with chemistry, physics and elementary engineering.

The consideration of the action of vehicles on the road surface and *vice versa* is clear and concise; it deserves to be well considered by every one who is interested in the road problem as there is much confusion and uncertainty on this aspect of the problem.

Another section worthy of every commendation is the chapter devoted to definitions and nomenclature. The application of the same or similar names to different substances and compounds in England, France and America has led and can only lead to misapprehensions and failure to take advantage of experience gained in other countries. It is gratifying to note that English nomenclature meets with his approval, and until a standard international nomenclature is established his summary of the differences will be most valuable. The second and third chapters are devoted to a description of the production and testing of tars, pitches and other binding materials, the latter of which is probably worthy of more careful attention than is always given to it, since some failures have undoubtedly been due to materials differing in composition and properties from those employed successfully elsewhere.

A discussion of the relative usefulness and suitability of various rocks and slags in combination with different binders would have been useful as a separate section, while the binder used in Rocmac deserves more space as it has advantages in certain situations probably not possessed in the same degree by other materials.

Considerable attention is given to the manner in which pot holes are formed and the obscure phenomena known as corrugation of road surfaces. No conclusion is put forward with regard to the latter, but the need for careful research is urged. It is probably not a simple problem and will resist resolution for some time as the related problem of the corrugation of steel rails subjected to electric traction has done although the conditions can be much more exactly determined in the latter case.

M. Gavrian has collected a considerable quantity of data on the tractive effort required on different types of road surface and for different types of tyres; this

is all to the good as the publication of authoritative figures should do much to reconcile transport owners to the high cost of modern roads by showing that there is reduction in cost in another direction. The destructive effect of certain kinds of tyre is also well brought out and may help towards their elimination if it brings home to the vehicle owner that any slight advantage he may gain individually has to be paid for eventually in greater expenditure on the road itself.

A standard English text-book of this type would be of great assistance to the student not only of highway engineering but of general engineering also, as the subject is too often neglected.

### Radio-Communication.

- (1) *Die drahtlose Telegraphie und Telephonie*. Bearbeitet von Dr. P. Lertes. (Wissenschaftliche Forschungsberichte. Naturwissenschaftliche Reihe. Herausgegeben von Dr. R. Ed. Liesegang. Band IV.) Pp. xi+152. (Dresden und Leipzig: T. Steinkopff, 1922.) 4s.
- (2) *Marine Wireless Pocket Book for the Practical Operator and Student*. By W. H. Marchant. Pp. vii+180. (London: Sir I. Pitman and Sons, Ltd., 1922.) 6s. net.
- (3) *Continuous Wave Wireless Telegraphy: A Non-Mathematical Introduction to the Subject of Wireless Telegraphy from the Engineer's Point of View*. By B. E. G. Mittel. (Pitman's Technical Primer Series.) Pp. xvi+114. (London: Sir Isaac Pitman and Sons, Ltd., 1922.) 2s. 6d. net.

THE development of the art of radio-communication has been so rapid that much of the apparatus described in technical books on the subject is either obsolete or is very little used. Its inclusion, however, may be justified on the ground that it is wanted by students for examination purposes. As the number of books on the subject is large and is rapidly increasing, the expert who reads them all will naturally weary of going over the same ground so often.

(1) Dr. Lertes's book will be of value as a work of reference. The descriptions are much too brief to be followed by any one who is not thoroughly familiar with the subject. A wealth of references are given which will be useful to any one who is making a special research on some branch of the subject. It would, however, be a help to the reader if the references were subdivided under various headings such as mathematical, physical, technical, and commercial. The ground covered is very wide and an account of the Johnsen and Rahbek electrostatic relay is included.

(2) This pocket book is intended principally for the

marine radio-telegraphist. Detailed instructions are given as to the methods of adjusting the various standard Marconi sets. Descriptions are also given of the apparatus of the Telefunken and Radio-Communication Co. The diagrams are very clear and the tables, rules, instructions, etc., included have been well selected.

(3) As the bulk of the world's radio-communication is carried on by continuous wave (C.W.) systems, it is natural that there should be a demand for elementary but accurate descriptions of these systems. The number of C.W. arc stations now exceeds a thousand, and more than 10,000 kilowatts have been installed for their operation. There are also many high frequency and valve generator stations. As space is limited in this booklet, some of the descriptions of important methods are too brief to be of much help to the reader, and there are notable omissions. The chapters on the advance of the C.W. system and on the Poulsen arc are instructive and contain novel matter. We can commend the book.

### Plant Morphology and Physiology.

*Practical Plant Biology: A Course of Elementary Lectures on the General Morphology and Physiology of Plants.* By Prof. H. H. Dixon. Pp. xi+291. (London: Longmans, Green and Co., 1922.) 6s.

A TEXT-BOOK by such an experienced teacher as Prof. H. H. Dixon is very welcome. To judge from the introduction, this book represents in condensed form the series of lectures which the author has found most suitable for the introduction of his subject to a class in which medical students predominate. At the end of each lecture brief notes are added as to the scope of the practical work to be carried out in conjunction with the course. Each lecture occupies on the average about eight pages, and in the thirty lectures a wide series of types are covered, from unicellular forms to the flowering plant. Considerable physiological work is included, and the subjects of nuclear division, heredity, and evolution occupy the last three lectures. The treatment is therefore of necessity much condensed, and an elementary student would find it difficult to use the book except under guidance.

Three salient features in the book have impressed the present reviewer. The first is the interest and charm with which the author's style and personality invests the subjects of the elementary course. It is clear that each time Prof. Dixon renews his acquaintance with these familiar plants, his class will find him filled with the enthusiasm of a first encounter. The student cannot forget that he is studying living plants,

even when examined in the remote region of a "microscopic field." With the aid of a "ghost micrometer," an instrument Prof. Dixon demonstrated to Section K of the British Association for the Advancement of Science at Edinburgh last year, comparative data as to size, rate of movement, etc., are always kept before the student. The brief instructions given on p. 74 for practical work with *Spirogyra* provide an excellent example of how to make a student realise that *Spirogyra* is a living object in a three-dimensional world, and not a design transferred from the plane of the microscopic image to the plane of the paper. The second striking point is that the author has found it advisable to build up a knowledge of the plant by progress from the simpler unicellular forms to the more complex vascular plants. The initial difficulty of the unfamiliarity of the plant forms thus first introduced to the student is grappled with most successfully, and very interesting use is made of the opportunity thus provided, at an early stage of the course, of indicating the great practical and human significance of biological studies. On the other hand, this method of approach appears to make the treatment of plant physiology more disconnected and less experimental. Photosynthesis appears fairly early in the course, but the experimental treatment at this stage does not encourage any effort to associate the process with gain in dry weight and in carbon content. Respiration is discussed first as an anaerobic process with yeast, and later is treated more generally under *Chlamydomonas*. While some general questions as to the water relations of the cell appear in Lecture II., root pressure and translocation, hinted at in Lecture XIX. on the fern, are not fully treated until Lecture XXV.

Coming to the third point of interest, as might be anticipated from the author, a much wider use is made of relatively complex data from physics and chemistry than is usual in an elementary botanical text-book. If botany is to progress this seems to be an essential development, even if it implies ultimately a recognition that elementary botany courses need building upon the physics and chemistry of the final years of the graduate science course! Lecture II. introduces us to diffusion and osmosis, Lecture III. to phenomena of the colloid state, Lecture IV. to enzyme action and surface phenomena in heterogeneous systems. This pace is rather sweeping and makes great demands upon the student. It is probably also inevitable that as botanists venture into these paths, the pioneers will stumble occasionally in their unfamiliar surroundings. The attempt to define the difference between a gel and a sol on p. 22 appears to be a case in point. The explanation here given of the structure of a gel would render the phenomena of diffusion in

such gels entirely unintelligible, and the experiment illustrating the retention of congo red by a gelatin gel must receive quite another explanation than that given to it.

### The Development of Vertebrates.

*Traité d'embryologie des vertébrés.* Par Prof. A. Brachet. Pp. xvi+602. (Paris: Masson et Cie., 1921.) 60 francs net.

FOR a remarkably clear and well-illustrated account of the development of the vertebrates the student could not do better than turn to this text-book from the pen of the distinguished professor of the University of Brussels. The information given is thoroughly up-to-date, the conclusions for the most part convincingly supported by an abundance of facts marshalled with great skill. While the author does not hesitate to discuss controversial questions, yet this treatise is strikingly free from prejudice, and none the less interesting because it deals for the most part with matters of fact. We find none of the fantastic phylogenetic interpretations of developmental stages according to the recapitulation theory which disfigure so many general text-books of embryology.

Naturally, in a single volume of some 600 pages, the whole range of vertebrate embryology cannot be covered in detail, and it is the early stages and germ-layer formation that receive particular attention. We know of no text-book in French or English with such a lucid account of these complex processes in the vertebrates. By skilful selection and the omission of unimportant detail Prof. Brachet also provides good descriptions of the development of the chief organs. The development of the cranial nerves, for instance, is particularly well presented.

There are some points on which the author is not convincing, and on which his conclusions might, we think, be revised and modified. In the account of the mesoblastic somites of the head, like so many other embryologists, he uncritically adopts van Wijke's scheme of enumeration, which inevitably leads to confusion in the region of the hyoid arch, instead of Balfour's system. We are unable to understand his reluctance to admit that in vertebrates above Amphioxus there are still traces of the formation of mesoderm from enterocoelic pouches, and we consider that he attaches too much importance to what he terms acrogenesis, cephalogenesis and notogenesis, a distinction which seems somewhat artificial and founded on certain specialisations of growth in the embryos of higher forms. Nevertheless, Prof. Brachet's volume is an excellent treatise, and will be heartily welcomed by students and teachers of embryology.

### Our Bookshelf.

*The Principle of Relativity.* Original Papers. By A. Einstein and H. Minkowski. Translated into English by M. N. Saha and S. N. Bose. With a Historical Introduction by Prof. P. C. Mahalanobis. Pp. xxiii+186. (Calcutta: University of Calcutta, 1920.)

THE book under review begins with an interesting historical account of the experiments dealing with the elucidation of the æther-idea in physics, and we are led through the work of Michelson and Morley, Lorentz and others to a brief account of Einstein's theory of relativity and some of the results obtained with its aid. The second section reproduces Einstein's original paper "On the Electrodynamics of Moving Bodies" (*Annalen der Physik*, 1905), and this is followed by a short note on Albrecht (!) Einstein and the various phases of his scientific activity. The next section on the "Principle of Relativity" is apparently a translation of Minkowski's paper on "The Fundamental Equations for the Electromagnetic Processes in Moving Bodies" (*Göttinger Nachrichten*, 1908), though no reference is given, and the title is omitted. An appendix to this is given, and it concludes with the well-known lecture of Minkowski on "Space and Time," delivered to the German Naturforscherversammlung at Cologne (1908), and published in the *Physikalische Zeitschrift* (1909) and in "Das Relativitätsprinzip," a collection of papers by Lorentz, Einstein, and Minkowski (Teubner, 1913). The sixth section of the book consists of Einstein's monumental work on the "General Theory of Relativity and Gravitation" (*Annalen der Physik*, 1916), and the concluding section brings a number of explanatory notes, mostly mathematical, on special points.

The translation cannot be called a good one. In a work of this kind we expect a fairly literal translation, but in the present book there are numerous errors in translation, and the choice of English equivalents for German words is frequently unfortunate. In many instances the mathematics is faultily reproduced. The numbering of the pages is not continuous, but recommences at the beginning of section 4, and the omission of the footnotes from the originals is regrettable. Provided it is studied with care, the translation will nevertheless be of service to those who are unfamiliar with German, and wish to grapple with the pioneer works on this subject, some of which are rather inaccessible.

*A Little Book on Water Supply.* By Dr. William Garnett. Pp. xv+144. (Cambridge: At the University Press, 1922.) 6s. 6d. net.

"THIS little book when in manuscript was condemned by a very high authority on educational publications, for it did not enable the reader to prepare for any specific examinations." So the preface begins. But was not the very high authority anxious to be kind? We, too, are inclined to condemn the little book as an educational work, not because it is useless for examinations, but because it lacks a coherent plan.

There is no attempt to group the portions of letterpress into chapters. General statements are sand-

wiched between local descriptions, thus "Aqueducts" are treated between "Storm Waters" and "The Water Supply of New York"; "Watersheds and Water-partings," with a long description and full-page illustration of the Rhone Glacier, appears between engineering details of the water-works of Glasgow and of Liverpool. And between "The Birmingham Water Supply" and "Proposals to supply London from Wales" there is an account of the Nile storage at "Assouan" in a paragraph devoted to "Other Famous Dams."

Apart from the absence of arrangement, the book fails in saying next to nothing of the rainfall of the country and its fluctuations, data for which in immense abundance are available; nothing of the system of legislation by which water supplies are allocated, save for scraps in relation to individual schemes. An appendix gives an account of the theory of cyclones put forward by Prof. Bjerknes; but there is nothing as to the distribution of rainfall in the actual cyclones which traverse the British Isles.

As a scrap-book of useful and often entertaining information on the supply of water to modern London and ancient Jerusalem the book will give pleasure to many readers, and the facts as to other cities, ancient and modern, are accurate wherever we have tested them, though not always up to date. Our sole complaint is that a scrap-book should be put forward as an educational work, for we hold that continuity of plan, clearness of arrangement, and simplicity of statement are essential for any such book, and these we do not find. We repeat that large parts of the book are excellent, and every Londoner would do well to read those which refer to the Metropolitan Water Board.

H. R. M.

*Étude géométrique des transformations birationnelles et des courbes planes.* Par Henri Malet. Pp. viii + 261. (Paris: Gauthier-Villars et Cie, 1921.) 32 francs net.

ORTHODOX elementary geometry deals principally with the metrical properties of space, based on Euclid's axioms. In the modern developments of geometry the metrical properties are a secondary consideration. The study of ordered aggregates of spatial elements, such as points, lines and planes, became a powerful weapon in the hands of the geometers of the last few generations, and one of the most useful forms of this study is the method of transformations and correspondences. M. Malet sets himself the task of presenting the fundamental ideas of correspondences, leading up to the generalised type which forms the title of his book. As is natural he offers first a careful study of homographic correspondences of points on straight lines, then the method of projection, coming finally to birational transformations. His method is purely geometrical.

The theory is applied to the type of plane curves called algebraic, defined by the author in the sense that one and only one algebraic curve can be made to pass through a number of given points in a plane, these points being independent: he examines carefully the meaning of independence.

Attention is directed to the remarkable fact that many

of the most important contributions to modern geometry have been made by Frenchmen; M. Malet claims that this is due to "ces qualités de clarté et de précision qui furent toujours l'appanage de notre race."

S. B.

*A Manual of Indian Timbers: An Account of the Growth, Distribution, and Uses of the Trees and Shrubs of India and Ceylon, with Descriptions of their Wood-Structure.* By J. S. Gamble. Reprint of second edition with some additions and corrections. Pp. xxvi + 868 + 20 plates. (London: Sampson Low, Marston and Co., Ltd., 1922.) 3l. 3s. net.

THE Empire Timber Exhibition, held in London in July 1920, was remarkable for the number of beautiful woods which were displayed in the India section. It was difficult to understand why most of these valuable timbers were either unknown or not appreciated in the European market. Most people in this country believed that teak was the only timber of importance produced in India, and were surprised to see the variety of species that were made up into furniture, panelling, parquet flooring, and a host of miscellaneous articles, ranging from fishing-rods to scientific instruments. The cause of the neglect of Indian woods may be put down to lack of business methods on the part of the Government, which controlled the great bulk of the forests. This supineness is now a matter of the past, and efficient measures have been taken to make known in England the wealth of timbers available.<sup>1</sup>

The publication of a reprint of Gamble's "Manual of Indian Timbers," which has been for many years out of print, is a step in the right direction. To those who are unacquainted with this splendid book, we may direct attention to the accurate mass of information which it contains on the timbers and forest trees of India, Burma, and Ceylon. About 1500 species are described; and their uses and qualities are pointed out.

*A Guide to the Identification of our more Useful Timbers: Being a Manual for the Use of Students of Forestry.* By Herbert Stone. Pp. viii + 52 + 3 plates. (Cambridge: At the University Press, 1920.) Price 7s. 6d. net.

THE distinctive characters of the commoner kinds of timber are well described in this brief manual, which should prove useful in teaching students. Thirty-one broad-leaved trees and ten conifers are included, all of which, except four, teak and three kinds of mahogany, are cultivated in this country. It is assumed that the student has sufficient knowledge of the elementary structure of wood to follow the descriptions. There are three plates. Certain slight errors in nomenclature should be corrected in the next edition. The term "deciduous oaks" is chosen to designate the two British species. This is not a distinctive name, as it does not include in this manual the American white oak and red oak, which are equally deciduous. *Ulmus effusa* (p. 18) is not a "bad" species, as alleged, but is a name applied to a distinct elm, not native to Britain, which is perhaps more correctly called by the prior name of *U. pedunculata*.

<sup>1</sup> See "Indian Trade Enquiry Reports on Timber and Paper Materials," published in 1921 by the Imperial Institute, where possible uses in this country for thirteen different woods, other than teak, are suggested.

## Letters to the Editor.

The Editor does not hold himself responsible for opinions expressed by his correspondents. Neither can he undertake to return, or to correspond with the writers of, rejected manuscripts intended for this or any other part of NATURE. No notice is taken of anonymous communications.]

## The Influence of Science.

THE ingenious letter under the above heading, on page 180 of NATURE of August 5, by that industrious astronomer of Stonyhurst College, Father Cortie, S.J., seems to require some brief notice because of the singular character of the statements made in it. We are asked to believe that Copernicus's "heliocentric doctrine was freely taught, even in ecclesiastical colleges, until Galileo interested himself as a champion of the system"; in spite of the admission that after this "truculent and hot-headed controversialist" had endeavoured to get the Church to realise that the doctrine was not really antagonistic to Scripture when reasonably interpreted, and after the offended Pope had brought the matter before the Holy Office, that authority determined that "the Copernican system was false and absurd philosophically." And we are also asked to believe that the outcome was merely that Galileo had as a penance "to recite certain prayers, and was sent to a beautiful villa at Arcetri"; the implication being that there was really no punishment, and that there was no call for anxiety or distress on the part of either him or his daughter throughout the proceedings.

Yet some of us have learnt from extant documents that Galileo was made to recant, to abjure and curse the theory of the earth's motion, and to promise to denounce to the Inquisitor any one suspected of similar heresy.

Some rather definite pressure must have been brought to bear upon the old man in order to secure this damning retraction—a retraction which the younger and more energetic Bruno a few years previously had contumaciously refused to make. Perhaps, however, it may be contended that in Bruno's case also the Cardinals "proceeded with all the gentleness and moderation which were compatible with judicial forms!" If so, it is a comfort to us scientific heretics of to-day that judicial forms have by this time lost some of their virulence and the Holy Office some of its power. The flail of orthodoxy is still wielded in high places, by searchers out of scientific heresy; but the penalties inflicted are no longer ecclesiastical, and—pace Father Cortie—are less severe.

On second thoughts it occurs to me that the letter may be intended humorously, in preparation for the suggestion that the Church and the Aristotelian professors had some inkling or precognition of the theory of relativity. Father Cortie summarises "the only proofs that were brought forward" for the heliocentric doctrine; and doubtless the court concluded, as modern self-elected authorities do in an analogous case, that "there is no evidence" for any modification of conservative tradition.

OLIVER LODGE.

## Action of Cutting Tools.

IN NATURE of July 22, p. 118, there is an interesting description by Prof. E. G. Coker of experiments in which the strains and stresses of a transparent material (celluloid) in the neighbourhood of the edge

of a cutting tool were made apparent by polarised light.

It ought to be noticed that the word "cutting" as applied to tools used for metal work (and hard substances), though generally in use, is incorrect, the actual action of such tools being to cause shearing.

Cutting and shearing differ in that in the former the part removed by the tool is merely bent, while in the latter it is at the moment of formation exposed to

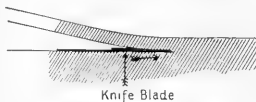

FIG. 1.—Cutting action of knife.

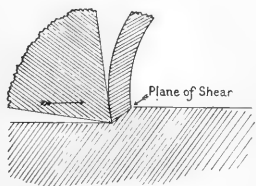

FIG. 2.—Shearing action of tool.

intense local shearing sufficient to cause permanent set or fracture throughout its whole thickness. This is illustrated in Figs. 1 and 2.

In connexion with this subject I may refer to a paper of my own (Proc. Roy. Soc., 1882), which, so far as I know, is the only place where the distinction has been made. There are very few tools and very few materials which lend themselves to true "cutting" (e.g. thin-bladed tools and soft substances like animal tissues), and in any attempt to "cut" hard materials the tool is soon brought up by the frictional grip of

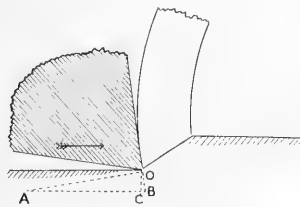

FIG. 3.—OA, normal force on face of tool; BO, frictional force on face of tool; OC, component of OA tending to make the tool "dig"; CO, component of BO tending to make the tool lift.

the material on the blade. In tools for hard materials (*i.e.* shearing tools) the friction of the shearing on the face of the tool is the chief factor in the determination of the angle at which the tool-face should be presented to the work. Any angle will cause the requisite shear, but unless the friction on the face balances the inward component of the force due to its slope, the tool will either tend to "dig" or to retreat from the material being operated on (see Fig. 3).

Thus for soft copper or aluminium, for example, where the coefficient of friction is large, the angle should be more acute than for brass, where the friction is much smaller.

A. MALLOCK.

9 Baring Crescent, Exeter.

### Rudbeckia and Aquilegia.

WHEN recently (July) collecting Eocene fossils in the vicinity of Roan creek, Colorado, I saw for the first time the singular composite *Rudbeckia montana* Gray in life. It abounds in the valleys and gulches, occupying similar positions to those in which one finds *R. laciniata* on the eastern side of the range. The latter, so far as I could ascertain, is absent from the region of *R. montana*, though it occurs in the south-western part of Colorado. The striking feature of *R. montana* is the total absence of rays. The large conical or cylindrical discs appear very black, slightly yellow from pollen when in flower. The involucre bracts are coarse and pointed, surrounding the base of the disc and diverging at various angles. The whole effect is most peculiar and unusual. Rayless Compositae are known in various genera, and occasionally occur as mutations in normally rayed genera. The ancestor of *R. montana* was presumably rayed, but losing its rays through a germinal modification, how did it manage to survive and flourish to the exclusion of the rayed form?

On July 21 I took particular occasion to watch a large group of *R. montana* on Dry creek, a tributary of Roan creek. The plants appeared just as attractive to bees as the rayed species.



FIG. 1.—*Rudbeckia montana*, Gray.  $\frac{1}{2}$  natural size.

They were being visited by great numbers of worker *Bombus*, the majority *B. rufocinctus phaceliae* Ckll., but there were also many *B. edwardsii bifarius* Cresson. Other bees were fewer, but I collected females of *Megachile pugnata*, say, *M. grindelarium* Ckll. and *Halictus trizonatus* Cresson. There were also two species of plant-bugs, *Lygæus relictivalis*, say, and *Lygus pratensis* L. Thus it seems certain that the loss of the rays has not interfered at all with cross-pollination by bees.

On the high mesa, between Roan creek and Salt Wash, in the aspen groves, I first saw the white-flowered sub-species of the Columbine, *Aquilegia carulea* James. The large white flowers, with long spurs (up to 90 mm.), dotted among the green shrubbery, were truly magnificent. One got the impression of a perfectly distinct species; but some of the flowers were suffused with bluish, and rarely one found a genuine *A. carulea* with blue, sepals. The flowers certainly averaged larger than those of *carulea*, but the spurs were long enough for Tidestrom's *pinetorum*, which seems possibly to be a habitat-form.

The locality on the Roan mountains is in the midst of a Canadian zone flora, with no pines, the only conifer being *Pseudotsuga mucronata*, which is abundant. *Pinus edulis* and *Sabina* occur on the slopes lower down. The underlying geological formation is the Green river Eocene. The white (*albiflora* Gray) sub-species of *A. carulea* may well have arisen by mutation from the blue-sepalled type, but how did it manage to supplant it? It cannot be a matter of the direct effects of the environment, since genuine *carulea* grows rarely in the same localities. Both forms are visited by Lepidoptera, and there is no reason for supposing that *carulea* is specially favoured by butterflies, *albiflora* by moths. In the locality of *albiflora*, as we found it, long-tongued moths must be very rare, but long-tongued butterflies (especially *Papilio*) abound.

These cases of *Rudbeckia* and *Aquilegia* are difficult to explain. Is it possible that, while there is no direct influence of the environment on the characters,

there is something in the soil (the shales being rich in peculiar organic products) which has affected the germ-plasm of the plants, bringing about a selective elimination of certain qualities?

T. D. A. COCKERELL.

University of Colorado, Boulder,

July 25.

### The Rat and its Repression.

THE valuable contributions on rat repression by Lord Aberconway and Lieut. Alfred E. Moore, which have appeared in the columns of NATURE, may, I venture to think, be usefully amplified by some reference to one of Britain's paramount industries: shipping, considered in the light of the rat menace.

Undoubtedly, rats represent a serious problem to the shipping industry, and I only suggest some possibilities that occur to me in the hope that others more competent may be induced to table something more valuable. Among the avenues to be explored are:—

(a) The possibility of an international agreement in regard to ship fumigation and disinfection, having special regard to ships arriving at British Empire ports.

(b) The possibility of stimulating invention in regard to ship-proofing: e.g. anchor chains, mooring ropes, gangways, and all shore connexions are avenues of infinite possibility when one is considering rat invasion.

(c) The possibility of stimulating research into the most effective means of destroying rats aboard ship by means of fumigation, electricity traps, raticides, etc.

(d) The possibility of creating a national board composed of the representatives of port authorities, ship owners, authorities on rat repression, and ship store superintendents, and of providing in connexion with such national maritime board suitable laboratories for testing and research.

(e) The possibilities of asbestos-concrete plus barium carbonate as a light and at the same time poisonous covering in the place of wood where its use would not be inconvenient.

It is doubtful if man has a more cunning foe than the rat, and in view of the fact that the vermin is ever increasing, and the rat's adaptability when it is called upon to vanquish obstacles to its depredations, it seems to me well worth our while to concentrate upon effective measures to counter the activities of our enemy.

DENBIGH.

The Bath Club, 34 Dover Street, W.I.,

August 4.

### The Spectrum of Helium in the Extreme Ultra-Violet.

MR. FRICKE showed (*Phil. Mag.* 41, May 1921) that in the extreme ultra-violet the arc spectrum of helium probably contained but one line with a wave-length near 585 Å.U.

I have recently attacked the subject again using a vacuum spectroscopy so arranged that a good vacuum could be maintained in the body of the apparatus while the discharge tube contained helium at a pressure of about a millimetre. No window was employed, the success of the device depending on the use of a very short and narrow slit and upon the suitable application of a powerful pump.

With a continuous current the line at 584.4 is of very great strength, and is accompanied by three new lines at 537.1, 522.3, and 515.7 whose intensities decrease with their wave-length and in a manner strongly suggesting a series relation. Luckily the

first three members appear in the second order spectrum, a comparison with the hydrogen line 1215.68 and with the three following lines of the same series is therefore possible, with the result that the wave-lengths are probably correct to one or two tenths of a unit.

The spacing of these four helium lines on the frequency scale is of great interest and importance, for it is found to be identical with the spacing of the first four lines in the singlet principal series. It may be stated, therefore, with considerable certainty that the line 584 forms the first member of a principal series, which, according to the notation of Prof. Fowler, is to be represented by  $\alpha S-mP$ .

Besides this series there is a single line at  $600.5 \pm 0.3$  of a feeble and diffuse character; its origin is not entirely above suspicion. In the extreme ultra-violet the arc spectrum of helium appears to contain no lines in addition to those just mentioned.

The relation between the accepted values of the resonance and ionisation potentials in helium and the wave-lengths of these new lines is rather puzzling. The ionisation potential should certainly correspond to the limit of the  $\alpha S-mP$  series; now this limit can be accurately calculated, it corresponds to 24.5 volts, but the experimental value is 25.3 volts. This is the chief difficulty, but it is not the only one, for the agreement between the wave-lengths of the individual spectrum lines and the values of the resonance potentials as determined by Franck and Knipping is not satisfactory. A correction of about  $-0.8$  volt, if applied to all the potential measurements, will bring the two sets of data into fair agreement, but at the expense of the first resonance potential which is left without any corresponding line in the spectrum.

The matter should be of some interest to those who are struggling with the model of the helium atom.

THEODORE LYMAN.

Jefferson Laboratory, Harvard University,  
August 3.

#### Transcription of Russian Names.

WITH regard to the recent correspondence in NATURE on the transcription of Russian names, may I direct attention to the fact that the Russian Academy of Sciences adopted a system of transliteration many years ago, and a note by Prof. J. W. Gregory giving the new rules appeared in NATURE on May 14, 1908, p. 42. In all the publications of the Academy the Latin transcription of Russian names is given in accordance with this system.

Since, in the event of Russia adopting the Latin alphabet, the Academy of Sciences, as the highest authority of the country, will be called upon to formulate the rules, I think it would be advisable for all countries to conform to the rules already set forth by this Institution.

It is needless to say that at present Russian transcription is in a very confused state, the name of the same author being frequently given in different ways (e.g. Choldokovsky = Kholodkovsky; Ivanov = Iwanow = Iwanoff).

CECIL A. HOARE.

Wellcome Bureau of Scientific Research, N.W.1.

July 25.

#### Sense of Smell in Birds.

THE observations with regard to the olfactory sense of vultures recounted by Mr. C. B. Williams (NATURE, July 29, p. 149) are at variance with those of hunters and field naturalists and the experiments of Audubon, Bachman, and Darwin (see Darwin's "Journal of Researches, Voyage of H.M.S. Beagle"). From *a priori*

reasons it could be argued that birds as a whole depend mainly on sight, and no one would be inclined to deny an obvious fact when it is emphasised by morphological modification. Ducks and geese and other birds which feed for long periods on land and marsh certainly have good powers of smell, but in the majority the sense is feebly or not at all exercised. The conclusions of Mr. Abel Chapman, given on pages 241 and 423 of his "Savage Sudan" (1921), that with few exceptions birds and certainly that eagles and vultures possess no sense of smell, deserve attention, for he is a wildfowler with a long experience. He has told me, among many interesting observations which prove the fact, that in the Sudan, when it is necessary to preserve meat from a carcass for mess purposes, all that is necessary is to remove it a short distance and cover it with branches. The vultures discover without delay the carcass and pick it clean, but fail to find the rich supply of meat so near them. The fact appears, therefore, to be that vultures use their telescopic eyes not merely to watch what is taking place over a wide range below them, but to note what their neighbours are doing. If one disappears, the rest in turn fly to the region to find out the cause.

ALEXANDER MEEK.

Armstrong College, Newcastle-on-Tyne, August 3.

#### A Coincidence in Values.

It is to be noted that if the simple multiple "seven" of the atomic heat (6.4) be taken a magnitude is obtained double that of the gram-molecular volume for the ideal gas (22.412 litres). On such a basis of reckoning the "ideal atomic heat" would be expressed by deduction from the ideal gas as 6.403.

Dulong and Petit's law would thus be stated: "The product of the atomic weight and the specific heat of an element in the solid state is constant, and for the ideal solid is exactly  $\frac{1}{2}$ ths of the gram-molecular volume for the ideal gas."

A linkage exists between the liquid and gaseous states through the gas constants. Although the solid state has not in any great measure adapted itself to what Van't Hoff termed mechanical constants, we can foresee the existence of a simple connecting link between all the three states of matter. The cynic, of course, will observe that much virtue doth abide in the magic number seven!

L. M. STEWART.

The University, Birmingham.

#### The Evolution of Consciousness.

YOUR reviewer, in a kindly notice of my book in NATURE of July 29, p. 147, sums up its general attitude in these words: "All that is, Mr. Tilby tells us, has emerged in a definite historical sequence, and we have merely to accept the fact and not ask why." May I point out that I did not say this, and I do not think it? Indeed, it conflicts rather glaringly with the thought I tried to express.

Certainly we have to accept the facts of the universe in their historical sequence; but we have to do something more than accept them—we have first to discover them before we can accept them. And of the major portion of those facts we are still unaware, as the fundamental contradictions of contemporary philosophers abundantly testify.

But to suggest that we are "not to ask why" is to commit treason against the intelligence. That lazy heresy was once popular in the circles of pious orthodoxy, and it has occasionally infected the more epicurean or more pessimistic type of agnostic. But this merely negative attitude will never satisfy. It is very largely because man has asked why that he

has progressed, and it is because he is still (and rightly) dissatisfied with the answers given that he continues to advance.

There may conceivably be a limit to the acquisitions and interpretations of a finite mind; but man is as yet so evidently in his infancy mentally, psychically, and even politically, that we are in no immediate danger of knocking our heads against that possibly predestined barrier to profitable inquiry. Nor do I for one believe that any such barrier exists. There is manifestly an Unknown, but I should hesitate to describe it as the Unknowable.

A. WYATT TILBY.

Howstean, Frinton, Essex.

I AM very glad to accept Mr. Tilby's disclaimer. I did indeed associate his evolution of consciousness with a certain theory of "emergence" made famous in an address to the Psychological Section of the British Association last year. I did not mean to suggest that Mr. Tilby's theory was obscurantist or dogmatic.

THE REVIEWER.

### Transparency of Liquids and Colour of the Sea.

In an earlier note in NATURE (Nov. 24, 1921, vol. 108, p. 402) I pointed out that the scattering of light in its passage through a liquid resulting from the local fluctuations of density, the magnitude of which is given by the Einstein-Smoluchowski relation, should enable its transparency to be determined for the parts of the spectrum in which it does not exercise selective absorption. It should be mentioned that in making an experimental test of this point, account has also to be taken of the scattering resulting from the anisotropy of the molecules and that there is an important difference between this and the scattering due to density-fluctuations. The orientation-scattering is almost completely unpolarised and is therefore distributed symmetrically in all directions. The density-scattering is polarised and is twice as intense longitudinally as in a transverse direction.

The coefficient of extinction resulting from the joint effect of both types of scattering can be calculated theoretically if the compressibility, refractive index, and the ratio of the components of polarisation in the transversely-scattered light are known. Taking the case of benzene as an example, the coefficients of extinction calculated for the 5461 and 4358 lines of the mercury spectrum, which fall in regions in which there is no selective absorption, are respectively 0.00022 and 0.00060. These values agree very closely with the recent experimental determinations of Martin, and form a striking confirmation of the theory. There is little doubt that the observed transparency of many other liquids will similarly be found to be in agreement with theory when accurate data are available.

The case of water is of special interest. Of all ordinary liquids it is the one for which the coefficient of scattering is smallest, and is therefore most affected by traces of selective absorption. There is an absorption band which is clearly marked up to  $0.5\mu$ , and it is possible that traces of it extend into the blue region of the spectrum. For the 4358 line, the coefficient of extinction calculated theoretically is 0.0006 and Martin's observed value is 0.00012. It seems probable that a little farther out in the violet, the transparency may agree more closely with that derived from the theory of scattering.

The newer data now available enables a quantitative test to be made of the theory put forward by me in a recent paper (Proc. Roy. Soc., April 1922) that the blue colour of the deep sea arises from the

molecular scattering of sunlight in water, the thickness of the effective layer being determined by the attenuation of the sun's rays as they penetrate into the liquid. The tentative calculations made in that paper have now been revised. The table shows the theoretical albedo of ocean water expressed in terms of the equivalent scattering by dust-free air at normal temperature and pressure.

ALBEDO OF OCEAN WATER.

Wave-length in $\mu$ .	0.658	0.602	0.590	0.578	0.546	0.499	0.436
Equivalent kilometres of air	0.5	0.7	1.8	2.8	5.2	7.0	15

It is evident from these figures that the blue of the sea would be much more saturated than the blue of the sky, which is the standard of comparison. The height of the homogeneous atmosphere being 8 kilometres, the sea would be about half as bright as the zenith sky on a clear day. This agrees well with the photometric determinations made by Luckiesh during aeroplane flights over deep ocean water in the Atlantic (*Astrophysical Journal*, vol. 49, 1919, p. 129). Luckiesh makes it clear that the greater part of the observed luminosity of water viewed perpendicularly really arises from light diffused upwards from within the water. His determinations thus appear to furnish a quantitative proof of the theory which attributes the colour of the deep sea to molecular scattering of light.

C. V. RAMAN.

210 Bowbazar Street, Calcutta.

### Telescopic Observation of Atmospheric Turbulence.

In his recent contribution to meteorology, "Physics of the Air" (U.S. Weather Bureau, Washington), Prof. Humphreys refers, in chapters 11, 12, and 14, under the general headings of "Wind Layers" (p. 219), "Wind Billows" (p. 221), "Barometric Ripples" (p. 228), and "Special Cloud Forms" (p. 296), to the demonstration by Helmholtz (translated by Cleveland Abbe, "Mechanics of the Earth's Atmosphere," Smithsonian Institution, 1891) that "adjacent layers of air differ abruptly from each other in temperature, humidity, and density, and therefore may and often do glide over each other with . . . a wave-producing effect." Prof. Humphreys proceeds, of course, to associate these demonstrations with the problems of atmospheric turbulence.

May I be allowed to point out, however, that it is *not* the case, as stated by Prof. Humphreys (p. 219), that "these air waves are seen only when the conditions of humidity at the interface are . . . just right" for the condensation of visible clouds—I speak from the experience of personal observations covering, intermittently, a period of upwards of twenty years. These "Wind Billows" or "Air Waves" of Helmholtz's demonstrations are always readily visible in the absence of clouds. The various directions of their flowings, and the order of their temporary stratification, are accurately legible by the method I employ of a projected telescopic image of the sun for the purpose of their observation. The "cautious aviator," instead of succumbing to the idea that he needs must fly in the face of "unknown danger," should know that the early stages of turbulence are—if only the sun is unclouded—at all times conspicuously and spontaneously recognisable by this very simple method of observation.

CATHARINE O. STEVENS.

The Plain, Boar's Hill, Oxford, August 9.



## Hesperopithecus, the Anthropoid Primate of Western Nebraska.

By Prof. HENRY FAIRFIELD OSBORN, American Museum of Natural History, New York.

EVERY discovery directly or indirectly relating to the pre-history of man attracts world-wide attention and is apt to be received either with too great optimism or with too great incredulity. One of my friends, Prof. G. Elliot Smith, has perhaps shown too great optimism in his most interesting newspaper and magazine articles on *Hesperopithecus*, while another of my friends, Dr. A. Smith Woodward, has shown too great incredulity in his article in *NATURE* of June 10. It is in reply to both these extremes that I have especially prepared for *NATURE* additional information regarding the fauna and habitat of this new Primate, and additional figures to show the comparison between

Book of Job (xii. 8), "Speak to the earth and it shall teach thee." In brief, I advised Mr. Bryan to drop all his books, as well as his attempts to grasp the meaning of the diversity of opinion among scientific writers, and to inquire of the earth only what it had to teach him. I added that he would not necessarily lose his religion, but that he would certainly become an evolutionist.

I presume it is widely known that Mr. Bryan is a native and prominent citizen of the State of Nebraska, and it is certainly a humorous coincidence that on March 14, only nine days after my advice was given, I received from the western part of the State of Nebraska the tooth from which has been named the

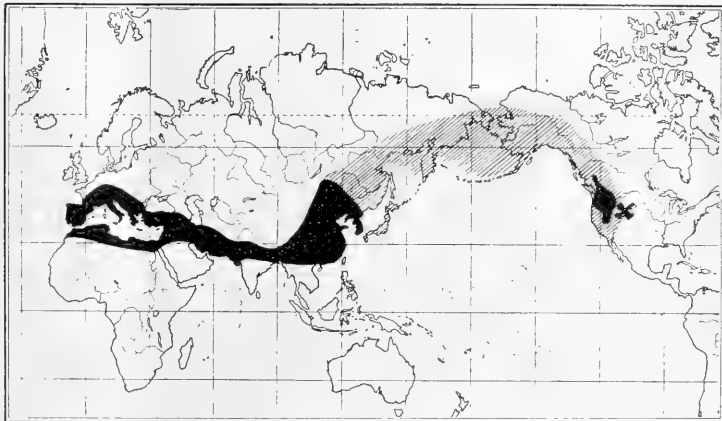

FIG. 1.—Upper Miocene and Pliocene distribution of the Strepsicerine and Hippotragine Antelopes. Known distribution in black, hypothetical migration area in oblique lines.  
X, Region of western Nebraska, Snake Creek beds, site of the discovery of the *Hesperopithecus* tooth.

the small, water-worn, type tooth of the genus (Fig. 2, 1-4) and the teeth which most nearly resemble it.

First, a word regarding the time and circumstances of the discovery of this Primate which happen to have a humorous side. Fresh and very violent attacks on the Darwinian theory have been made during the last two or three years all over the United States, especially under the leadership of William Jennings Bryan, a man of ingenious and fertile mind and persuasive powers of oratory, gifted as a politician and as a religious advocate. As an opponent to Darwinism, Mr. Bryan's attack culminated in his very carefully prepared article in the *New York Times* of Sunday, February 26, 1922, in which he ably fortified his position by long quotations from Prof. W. Bateson's Toronto address recently published in *NATURE* (April 29, p. 553), and by other critics of Darwinism. The following Sunday, March 5, I replied to Mr. Bryan, and realising that quotations from the highest scientific authorities in the world would not have the slightest influence upon him or his followers, I referred him to the writings of St. Augustine, also to the Holy Scriptures, and especially to a passage in the

Ape of the Western World (*Hesperopithecus*). This is the very first evidence, after seventy-five years of continuous search in all parts of our great western territory, of a Primate of any kind above the ranks of the numerous Lemur-like and *Tarsius*-like lower Primates which have long been known in our Eocene beds.

While we have all eagerly looked forward to such a discovery, and I have always regarded it as possible, I have never regarded it as probable, for the reason that the higher Primates, seeking the protection of forests, never venture out for long distances on the plains; moreover, accustomed to a forest fruit supply, they would have been exposed to great dangers in migrating from Asia to western North America except by the aid of a continuous forest belt or of a rather dense forest and savanna belt bordering a plains belt. In 1910 I published in my "Age of Mammals" (page 336, Fig. 156) a map, which I now send to *NATURE* for reproduction (Fig. 1), with indications of such a life belt for animals of the plains—antelopes and horses; adding an X to show where *Hesperopithecus* was found.

Since 1910 additional discoveries have been made which tend to indicate the existence also of a continuous forest and savanna belt between eastern Asia and western North America (black area and oblique lines), for we have found animals related to the strepsicerine and hippotragine antelopes, to the plains ungulates remotely related to the kudu, to the sable antelope, and to the eland (*Taurotragus*). We have also traced the migration of two kinds of forest- and savannaliving mastodons over this entire region, namely: (1) of proboscideans closely related to the *M. arvernensis* of southern Europe, to the *M. sivalensis* of India, and to the *M. mirificus* of western Nebraska, specimens of which have now been found in the very Snake Creek

three kinds of antelopes and of the two kinds of mastodons above mentioned. Finally, of the utmost rarity are the remains of the Primates, because during the eight seasons of continuous and expert search we have only discovered two teeth, namely, the tooth now regarded as a third superior molar of an old individual of *Hesperopithecus* found by Dr. W. D. Matthew in 1908, and the type tooth of *Hesperopithecus haroldcookii* found by the geologist Harold J. Cook in 1921. We are this season renewing the search with great vigour and expect to run every shovelful of loose river sand which composes this deposit through a sieve of mesh fine enough to arrest such small objects as these teeth. Even by this most laborious and painstaking method

the probability of finding more material is not very great, for the reason that the anthropoid Primates have always been very clever and resourceful animals, climbing into trees in times of flood, avoiding the low sandy levels and water-courses where ungulates are trapped.

Before re-examining the new figures (Fig. 2) of the *Hesperopithecus* tooth, may I quote verbally, with some unessential omissions, my own original characterisation of the tooth, for which I alone am responsible.

This second upper molar tooth is very distant from the gorilla type, from the gibbon type, from the orang type; among existing anthropoid apes it is nearest to  $m^2$  of the chimpanzee, but the resemblance is still very remote. . . . Thus the proportions of the molar crown of the *Hesperopithecus* type are about the same as those in the *Homo sapiens mongoloides* type. There is also a distant human resemblance in the molar pattern of *Hesperopithecus* . . . to the low, basin-shaped, channelled crown in certain examples of *Homo sapiens*. But the *Hesperopithecus* molar cannot be said to resemble any known type of human molar very closely. The author agrees with Mr. Cook, with Dr. Hellman, and with Dr. Gregory, that it resembles the human type more closely than it does any known anthropoid ape type; consequently, it would be misleading to speak of this *Hesperopithecus* at present as an anthropoid ape; it is a new and independent type of Primate and we must seek more material before we can determine its relationships. It is certainly not closely related to *Pithecanthropus erectus* in the structure of the crown, for *Pithecanthropus* has a single, contracted crown in which the superior grinding surface has a limited crenulated basin, whereas *Hesperopithecus* has a widely open crown with broadly channelled or furrowed margins, and a postero-internal crest suggesting the hypocone of a higher Primate form. . . .

The type description, as published in the American Museum *Novitates*, April 25, 1922, requires little or no modification as a result of two months of intensive research which has been devoted to this tooth, detailed results of which will shortly be published by my colleague, Prof. Gregory. The accompanying new illustrations (Fig. 2), prepared especially

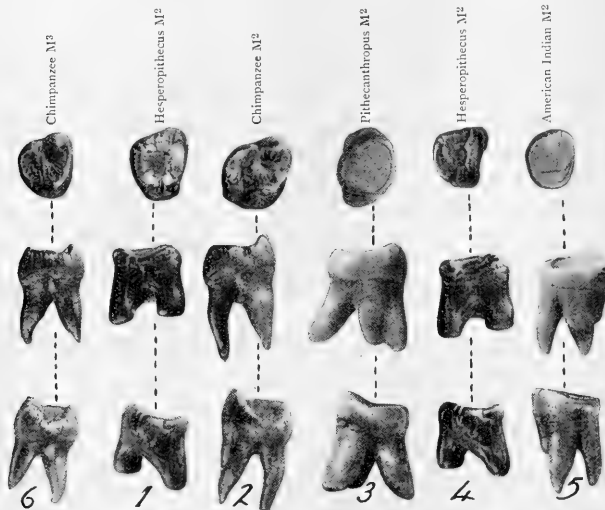

FIG. 2.—Comparison of the Second Superior Molars of the Right Side of the Upper Jaw in the Primates.

Upper row: crown views of the superior molars.

Middle row: anterior views of the same teeth.

Lower row: posterior views of the same teeth.

(1) *Hesperopithecus*, the new Nebraska Primate, middle-aged.

(2) *Anthropopithecus*, a young chimpanzee.

(3) *Pithecanthropus*, adult Trini Ape-man.

(4) *Hesperopithecus* (photographed in a different light).

(5) *Homo sapiens mongoloides*, aged North American Indian.

(6) Third superior molar of *Anthropopithecus*, a young chimpanzee.

All photographed to the same scale and natural size.

beds in which *Hesperopithecus* was discovered; also (2) of the true forest-living proboscideans of the genus Mastodon recently recognised in the Snake Creek beds. A true elephant (*E. hayi*), which resembles the *Elephas planifrons* of the Upper Siwaliks of India, has been found in more recent deposits.

From these relatively new and most significant discoveries we may characterise the Snake Creek region of western Nebraska, in Middle Pliocene time, as in the belt of the south Asiatic forest, savanna, and plains fauna, which extends two-thirds of the way around the entire globe, from the region of Britain to the central-west region of the United States, and probably right across to the Atlantic coast. The plains element in this fauna is extremely abundant, especially the Hipparian; somewhat more rare are the true horses (*Pliohippus*), and still more rare are the remains of the

for NATURE, are photographs of a most convincing character, in which the *Hesperopithecus molar* (Fig. 2, 1-4), in three aspects, is placed directly between corresponding molars of a chimpanzee (right and left) which most nearly resemble it. It will be seen at once (1) that the *Hesperopithecus molar*, although greatly water-worn, has entirely different proportions from the chimpanzee molar: it is much broader transversely; it is much narrower in the fore-and-aft dimensions. This affords positive evidence that *Hesperopithecus* had a shorter facial region than the chimpanzee. In this respect it approaches the mongoloid human type (Fig. 2, 5) more closely than it does any of the anthropoid ape types; (2) the roots of the *Hesperopithecus molar* are much more robust and more human in proportion than those of any of the frugivorous apes; (3) the upper molar of *Hesperopithecus*, while resembling the upper molars of certain American Indians of mongoloid type in several absolute measurements, differs widely in the more asymmetrical form of the crown, which is broader in front and narrower behind, whereas in the mongoloid human molars the crown is more symmetrical; (4) the type upper molar of *Hesperopithecus* differs from the corresponding molar in the Trinil Ape-man (*Pithecanthropus*) (Fig. 2, 3) in nearly all its absolute measurements; but it resembles the *Pithecanthropus molar* in the wide size of the internal (lingual) fang, also in the great separation of the internal (lingual) and external (anterobuccal) fangs. It also resembles *Pithecanthropus* in the evenly concave depression of the grinding surface, which is quite unlike the ridged form of the grinding surface observed in a chimpanzee molar (Fig. 2, 2-6); (5) as for the comparison suggested by Dr. Smith Woodward with the third lower molar of the Pliocene bear (*Hyænarctos*), the differences are so fundamental that it is difficult to find any single point of agreement; the molar of *Hesperopithecus* very clearly conforms to the flattened tritubercular to quadritubercular type which characterises all the upper molars of anthropoid apes and of man.

Thus, after making due allowance for the characters resulting from the prolonged natural usage of the *Hesperopithecus molar*, also for characters due to long exposure to erosion and stream action, and to percussion by the sharp sand of the river bed, there nevertheless remain five outstanding characters, as well as many

highly significant details of character, which tend to show that this tooth belongs to one of the higher Primates, and that this genus ultimately may be included either within the Simiidae (anthropoid apes), or near certain ancestors of the Hominidae (human stock).

I desire to summarise with emphasis my original statements about this tooth, namely, that among existing anthropoid apes it is nearest to  $m^2$  of the chimpanzee, but the resemblance is still very remote . . . that the proportions of the molar crown of *Hesperopithecus* are about the same as in *Homo sapiens mongoloides* (American Indian) type . . . that there is also a distant human resemblance in the molar pattern of *Hesperopithecus* to the low, basin-shaped, channelled crown in certain examples of *Homo sapiens* . . . that the *Hesperopithecus molar* cannot be said to resemble any known type of human molar very closely. It is certainly not closely related to *Pithecanthropus erectus* in the structure of the molar crown . . . it is therefore a *new and independent type of Primate, and we must seek more material before we can determine its relationships.*

My original characterisation and description have been fully confirmed by the intensive research of the past two months. I have not stated that *Hesperopithecus* was either an Ape-man or in the direct line of human ancestry, because I consider it quite possible that we may discover anthropoid apes (Simiidae) with teeth closely imitating those of man (Hominidae), just as we have discovered in the true Pittdown man (*Eoanthropus*) teeth closely imitating those of the chimpanzee. There are so many crisscross adaptations of this kind among the mammals that we can never be sure about the family relationships of an animal until we secure not only the teeth but considerable parts of the skeleton as well. No anatomist in the possession of *Pithecanthropus* molars only would have discovered the human resemblance which is indubitably established by the roof of the cranium, by the shape of the brain, and by the shape of the thigh bone. For similar skeletal parts of *Hesperopithecus* we are making most determined and prolonged search in the type locality; it is not at all probable that the desired evidence will be easy to secure. Until we secure more of the dentition, or parts of the skull or of the skeleton, we cannot be certain whether *Hesperopithecus* is a member of the Simiidae or of the Hominidae.

## Science in Egypt.

By Col. H. G. LYONS, F.R.S.

THE important part which modern science can play in the economical development of natural resources is generally recognised to-day, but nowhere may this be seen more clearly than in Egypt, with its subtropical climate, its controlled water-supply, and its immunity from the vagaries of the weather which affect more northern latitudes. Here a population which in 1882 was under seven millions has now grown to more than twelve millions, and inhabits a cultivable area which does not exceed seven million acres all intensively cultivated; for much of the area, which was formerly flooded annually and then furnished a single crop after the river had fallen, is now under perennial cultivation with a supply of water at all

seasons, and consequently up to five crops in two years are taken from it. Under these conditions the most economical use of the material resources that science can devise, and all the improvements that it can suggest, are of the utmost importance to the country.

During Egypt's period of financial difficulty the provision for scientific work was very meagre, but with the reorganisation of the irrigation and the introduction of reforms, an improving revenue enabled gradually increasing grants to be made to state departments, and many of them have, during the past thirty years, established services in which scientific work of value and importance has been carried on.

Some scientific work had been initiated at a much

earlier date, for the medical school at Qasr el Aini was established early in the last century, and about 1860 a 20-centimetre astronomical refracting telescope by Brünner of Paris, with an equatorial mounting, was set up at Abbassia; a four-metre base-bar together with two 40-centimetre theodolites and a portable transit instrument by the same firm were purchased for the survey of Egypt which was then projected, but which did not become an accomplished fact until about fifty years later.

To-day there are at least a dozen services occupied primarily with work of a scientific character.

The Survey of Egypt is the successor of the earlier surveys of 1823, 1853 and 1878, but none of these were ever completed nor had they any scientifically organised control. It now comprises the cadastral survey, the topographical survey, the desert survey, and the geological survey.

The cadastral survey is of special importance in Egypt on account of the high value of agricultural land, and the exceptional degree of subdivision of the holdings. The network of triangulation on which it is based now covers the Nile Valley and Delta, and is controlled by the first-order triangulation now in progress, which is of the standard demanded in international geodetic work. The topographical survey utilises the material provided by the cadastral survey and adds to it all topographical information besides extending the maps beyond the limits of the cultivated land, to meet the needs of different branches of the public service. There are now published series of map sheets on scales of 1 : 2500, 1 : 10,000, and 1 : 50,000, covering all the inhabited area of the country, while other maps on scales of 1 : 250,000 and 1 : 1,000,000 include the large areas of desert as well.

Survey work as it is extended into the desert assumes a special character, for on account of the large areas to be covered, the difficulties of transport, and the absence of all artificial topographical features, special methods of surveying have been adopted. This work is now in the hands of the Desert Survey, which also undertake the precise location and demarcation of prospecting and mining areas leased by the Government.

On the highly cultivated alluvial plains of the Nile Valley and the Delta accurate levelling is of special importance, so a network of levelling of high precision has been carried over them and extended into the Sudan along the Nile. Besides this the cultivated area throughout Egypt has been contoured at 50 centimetre intervals. At the headquarters of the Survey of Egypt are drawing, photographic, and printing offices in which are produced the maps of the various surveys and also those which are required by the geological survey and by other State departments.

In 1896 a geological reconnaissance of Egyptian territory was authorised which, at the end of five years, developed into a geological survey. The staff has always been small, but a very large amount of valuable work has been done under the difficulties and limitations imposed by desert travel.

Not only have the mineral resources of the country been located and described, thereby becoming available for commercial purposes, such as the phosphate deposits in Egypt and manganese deposits in Sinai, but

our knowledge of the structure and stratigraphy of north-eastern Africa has also been greatly advanced, and the interesting fauna of Lower Eocene age which was brought to light in the desert to the west of the Fayum has greatly extended our knowledge of the past history of the African continent. Geological work has been carried out for several years in connexion with petroleum research in the Red Sea area, and the results have been published in various reports. The records of the geological survey and the collections which fill its museum provide a store of information relating to the structure and stratigraphy of the Nile Basin and north-eastern Africa.

The Physical Department, which until a few years ago was part of the Survey Department, and is now a part of the Ministry of Public Works, includes the Helwan Observatory with its time service, the meteorological service, the service of weights and measures, and the hydrological investigations in connexion with the Nile. The observatory, which was formerly at Abbassia, was removed in 1904 to Helwan, 20 km. south of Cairo, because the building at Abbassia was wholly unsuitable and the extension of the electric tramways to its neighbourhood prevented all magnetic work. In it the 30-inch reflecting telescope at Helwan is employed in the photography of southern nebulae, of comets when they appear, and of Jupiter's eighth satellite, which has been observed almost exclusively by Greenwich and Helwan since its discovery.

The time service is also directed from the observatory, and the observatory clock transmits the noon time signals which are utilised at Cairo, Alexandria, Port Said, and at Khartoum. Magnetic observations are carried out both by means of magnetographs and by weekly absolute determinations. The meteorological service of Egypt and the Sudan includes, besides the central observatory at Helwan, 57 climatological stations, of which 23 are in Egypt, 27 in the Sudan, and 7 in Palestine, and about 230 rainfall stations in Egypt, the Sudan, and Abyssinia. First established to study the conditions determining the Abyssinian rainfall, and consequently the Nile Flood, it has now a much wider importance and is one of the recognised national meteorological services.

The increasing demands of agriculture and its dependence on the supply of water provided by the Nile have necessitated a high precision in river-gauging, and the hydrological work which this involves is now centred in the Physical Department, where the records of 70 river-gauge stations are discussed, and hydrological investigations are undertaken. The storage of water in the valley of the Nile at various points, the need for accurate measurements of the discharge throughout the low stage of the river, the study of the effect of turbulence in the water at flood stage, etc., present a series of physical problems which are of direct importance to Egypt, as well as being of great interest to many other countries.

The department is also charged with the inspection of weights and measures throughout the country, and the prototype standard metre and the secondary standards of length, which were acquired for the purpose of the Survey of Egypt, are now kept at the Helwan Observatory, where any comparisons desired are carried out in a well-equipped comparator house.

Weights are compared with standard copies at the observatory, and sets of certified weights are supplied to all who require them.

The Government analytical laboratory and assay office undertake a large amount of important work which falls under the headings of (a) chemical and physical inspection of materials; (b) technical chemical consultations; and (c) experimental research. Stores and materials of inferior quality frequently find their way on to the Egyptian market, and only by the systematic analysis of material tendered can these be eliminated and economies effected. To the same end the technical clauses in specifications governing supply by contractors are drafted by the staff of the laboratory.

The chemical work carried on in connexion with criminal investigation and other legal matters forms a branch of work which demands much time and great care. Recently published reports indicate that the consultative and research work is at present mainly related to questions affecting petroleum, and the development of petroleum resources in Egypt has given rise to an inquiry into the actual conditions under which petroleum products are used in Egypt, which was undertaken by the laboratory. The small refinery which the Egyptian Government has recently installed at Suez to deal, in the first instance, with royalty petroleum only, but with a view to its ultimate extension if that is found to be desirable, is also under the supervision of the director of the laboratory.

The first medical school in Egypt was formed in 1827 at Abu Zabel by Clot Bey, a French doctor in the service of Mohammed Ali, and ten years later it was transferred to Qasr el Aini on the south side of Cairo, where it still remains. For many years the number of students was small, but of late the school has been much enlarged and the number now amounts to 387. Attached to the school is the Qasr el Aini hospital, and these two form an important centre of scientific work in the country. There are now in the medical school well-staffed departments of biology, physics, chemistry, anatomy, physiology, pathology, and pharmacology, and in all of these not only is instruction given to students but research is carried on by the staff.

Although the number of scientific men in the institution has until recently been too restricted to admit of much research being undertaken in addition to teaching, several important investigations have been carried out; among these may be mentioned the study of the anatomy and racial characteristics of the ancient Egyptians, and of those neighbouring races whose remains occur in the cemeteries of the Nile Valley, and the comparison of them with the present inhabitants has added greatly to our knowledge of the Mediterranean peoples; the investigations which have been carried out of the life history of *Ankylostoma* and *Schistosomum* (*Bilharzia*) have done much to place our knowledge of these on a sound basis, the *Bilharzia* organism having been discovered in these laboratories, while work of no less importance has been done on the treatment of the diseases which are caused by these parasites. Valuable work on pellagra has also been done recently. Not only is there much more to be investigated in the interest of Egypt itself, but the special conditions, climatic, racial, etc., which occur

there provide opportunity for many promising lines of research.

The Department of Public Health, which dates from 1886, is also actively working in the same scientific field and, in addition to the administrative work which it carries on throughout the country, maintains several branches specialising in scientific work. Under the director of the laboratories of the department the water service carries out a regular inspection of all public water supplies, whether in the hands of the Government, municipalities, companies, or private individuals. The examination of substances having a direct bearing on questions of hygiene, such as foodstuffs, drugs, etc., is also undertaken in these laboratories, as well as the chemical and bacteriological examination of water.

Here too research on the main diseases of the country, *ankylostoma*, *bilharzia*, and typhus, is in progress with the co-operation of eminent specialists, and in this connexion the recent work of the late Mr. Bacot and of Dr. Arkwright will be recalled. An antirabic institute provides for the treatment of persons bitten by rabid animals. The annual reports of the Department indicate the wide scope of the scientific investigations which have to be undertaken in the course of its work, and highly expert assistance must without doubt be employed if they are to be brought to a successful conclusion under the peculiar conditions which an arid subtropical climate provides.

The special conditions which obtain in Egypt, a highly fertile soil, a controlled water supply rendering agriculture independent of rainfall, and a moderately hot climate, form the foundation of its agricultural wealth; the prosperity of the country depends on the efficiency with which these favourable conditions are utilised, and to this end the irrigation engineer, the entomologist, the economic botanist, and the agricultural chemist are working in co-operation. Perennial irrigation has now been extended until about half the cultivable area is supplied with water at all seasons of the year, with the result that in normal years about 32 per cent. of that area is occupied by cotton. It will be evident therefore that the scientific institutions of the Ministry of Agriculture are of the highest national importance, and on their efficiency Egypt's prosperity must mainly depend.

In 1919 a Cotton Research Board was appointed with the object of bringing together the heads of all the technical departments which were interested in the cotton crop, and to ensure that all problems relating to it were dealt with as adequately as possible. It was also to provide laboratory accommodation for investigators engaged in research on cotton. In its first annual report published last year the experimental work upon cotton which had been undertaken was reviewed, and a programme for further work at the scientific institutes of the Ministry was outlined. These institutes include laboratories, experimental farms, gardens, etc.

The chemical laboratory of the Ministry, which undertakes examination and study of soils, water, manures, feeding stuffs, and agricultural products, is situated close to the botanical laboratory and the experimental farm. The work carried on at these has for its object the improvement of cotton, wheat, and

other crops which are grown in the country, on the basis of field selection combined with self-fertilisation and hybridisation. One important and promising research which is in hand is the effect of the gradually diminishing "sharaki" (waterless) period on the soil flora. Propagation in bulk of improved strains of wheat and cotton is arranged with the State experimental farm and with selected private cultivators. The fungoid and bacterial diseases of Egyptian crops in general and of cotton in particular are investigated, and means for their control are devised and tested.

The supply of trustworthy cotton seed of the best growths is so important in order to produce a high quality of staple, and the opportunities of mixing good seed with inferior qualities before it reaches the cultivator are so many, that the Ministry actively interests itself in the matter, through the botanical laboratory.

To this may be added the important work which is being done on the flowering-curve method as an index to the effect of environmental conditions; or investigations of the causes of bud-shedding; and on the root systems of cotton plants. Similar attention is being paid to millet, rice, opium poppy, beans, and sesame; and sugar cane will be added shortly.

The Entomological Section undertakes the study and investigation of insect pests and advises on methods for their control. The fumigation of all cotton seed produced in the ginneries of Egypt is also controlled by this section, and samples of the seed obtained from ginning are sent to it for germination and examination for worms.

The work of the horticultural section should also be mentioned, for in it much work is being done in introducing and acclimatising new species or varieties of trees, and farm and garden plants.

Thus a beginning has been made to provide the scientific organisation necessary for the development of agriculture on sound lines, but something on a larger scale will be needed before it can be adequate to the country's requirements. In these institutions a number of questions of first-rate importance to the Egyptian cultivator are under study, such as the effect on the cotton crop of a high subsoil water-table, of rotation in irrigation, of reduced watering, and many others, and for their satisfactory solution the provision and efficient maintenance of a highly trained and experienced scientific staff is essential.

The scientific diagnosis and investigation of animal diseases are carried out at the veterinary pathological laboratory which was opened in 1904, and the Serum Institute, which dates from 1903, provides the anti-cattle-plague serum required for the immunisation of cattle against cattle plague both in outbreaks and as a preventive measure.

Outside the State departments science is not widely represented in Egypt. There are a few scientific societies, of which the oldest is the Institut d'Égypte, which was founded in 1859; its object is the study of all that concerns Egypt and the surrounding countries from the literary, artistic, and scientific points of view. The Geographical Society was founded in 1875 and publishes bulletins and memoirs at intervals. In 1925 the fiftieth anniversary of its foundation is to be the occasion of an international geographical conference.

The Cairo Scientific Society, founded in 1898, is an active institution which meets fortnightly throughout the winter half of the year and publishes its proceedings monthly in the *Cairo Scientific Journal*. At Alexandria a hydrobiological institute has been recently established, and much important work awaits the scientific research which should be undertaken there. But these are all too few for the needs of the country, and their paucity suggests a lack of appreciation of the importance of scientific knowledge.

In spite of difficulties due to the war, which Egypt has experienced in common with most other countries, science has of recent years been playing a more and more important part in the development of the country and its resources. The conditions there prevailing often differ widely from those which have been studied in other countries, and much research by scientific men of high training and wide experience will be necessary before the many problems which present themselves are solved. Such work is not in the interest of Egypt alone, for much that is done there will, if it is of a high scientific standard, be a permanent addition to the general stock of knowledge. Egypt in the past has benefited largely by the science and technical skill which has been gradually built up by generations of students in many lands, and she may now furnish her own quota in return by scientific research in the many fields of inquiry which the Valley of the Nile affords.

## Gelatin.

By Dr. T. SLATER PRICE.

GELATIN, in the form of glue, has been so long known that, according to Dr. Bogue (*J. Franklin Inst.*, 1922, vol. 193, p. 795), "we are unable to penetrate the archives of the human race to a date where we may say with assurance that glue was not yet discovered. Certain it is that this material was in use as an adhesive in the days of the great Pharaohs of Egypt." As glue, or κόλλα, it has given us the term "colloid," and at the time when this term was first used by Graham it was supposed that all colloids were substances of very complex constitution, such as is glue. This, however, is by no means the case, since what are known as the suspensoid colloids may consist of the elements them-

selves, e.g. colloidal gold and silver. The emulsoid colloids, however, consist to a large extent of very complex chemical substances, as, for example, the proteins, and it is to this class that gelatin belongs. Because of its complex constitution the chemical investigation of gelatin and of the processes which occur in its extraction from bones and hides is still in its infancy, and essentially progress has only been made in the direction of the examination of the degradation products. It is therefore not to be wondered at that the enormous literature on gelatin consists, to a very great extent, of accounts of results obtained in the investigation of its colloidal properties.

Naturally, the earliest physical properties to be investigated were the viscosity of the sol and the swelling of the gel, and it was soon found that the relations were very complicated, depending on previous history, even in systems made up from gelatin and pure water alone. For example, shaking, or repeated passage through a viscometer, will decrease the viscosity of a gelatin sol; at ordinary temperatures the viscosity of a freshly made sol gradually increases, whilst that of a freshly diluted sol gradually decreases; in a freshly made gel the intensity of the Tyndall effect gradually increases; and so on, all indicative of the formation of a structure and of the attainment of an equilibrium of some kind.

If the results obtained with gelatin in pure water are so complicated it is no wonder that they are still more so in the presence of acids, bases, and salts. Von Schroeder showed that in the presence of either hydrochloric acid or sodium hydroxide a maximum viscosity of the sol is attained at a low concentration of either of these substances. Again, according to other investigators, the effect of equivalent (tenth normal) solutions of various acids on the swelling is indicated by the following series, which is known as a Hofmeister series, after the investigator who was the first to examine the effects of different salts on the physical properties of the proteins:

HCl > HNO<sub>3</sub> > acetic acid > H<sub>2</sub>SO<sub>4</sub> > boric acid.

With the sodium salts of various acids the swelling decreases in the order:

Thiocyanates > iodides > bromides > nitrates > chlorates > chlorides > acetates > tartrates > citrates > sulphates.

Moreover, the order in the series may be affected by the concentrations of the substances used.

Such series are very difficult to understand, since the order of the compounds does not bear much relation to their ordinary chemical properties; for example, it is difficult to understand why acetic acid comes between nitric and sulphuric acids.

A way out of such difficulties has been found in recent years by the realisation that gelatin, like other proteins, behaves as an amphoteric substance and that its properties in solution depend on the hydron concentration. For progress in this direction we are chiefly indebted to the work of Procter in England, Pauli in Austria, and Loeb in America, the basic ideas being due to Michaelis and Sørensen.

Gelatin is a stronger acid than base, so that hydron, in the form of an external acid, has to be added to the solution in order to bring the gelatin to the isoelectric condition. At the isoelectric point the hydron concentration,  $C_H$ , is approximately  $2.5 \times 10^{-5}$ , that is, the pH ( $= -\log C_H$ ) is 4.7, which is on the acid side of the neutral point of water (pH = 7.0). The theory of amphoteric electrolytes shows that at the isoelectric point their solutions should contain a maximum number of neutral particles and should therefore possess peculiar properties; in accordance with this it is found that the properties of swelling, viscosity, osmotic pressure, etc., show a minimum at that point.

On the acid side of the isoelectric point, *i.e.* at pH < 4.7, gelatin should behave as a base and form gelatin-acid salts, whilst on the alkaline side, pH > 4.7, it should act as an acid and form metal gelatinates. Loeb has endeavoured to show that this is true in

several ways, of which the following may be quoted, where use is made of silver nitrate and gelatin which is brought to different pH's, all less than pH = 7.0, by treatment with varying concentrations of nitric acid. It can be predicted that on the alkaline side of the isoelectric point the gelatin, when treated with silver nitrate, will combine with the silver forming a silver gelatinate, and that the amount formed will be greater the higher the pH. If such a silver gelatinate is formed the silver should not be readily washed out by water and should remain in the gelatin after washing. On the acid side of the isoelectric point the gelatin should form gelatin nitrate, and it should be easy to remove the silver by washing. The following analytical figures show the agreement between theory and experiment.

*c.c.* 0.0rN-Ag in combination with 0.25 gm. Gelatin at different pH's.

pH	3.6	3.7	3.9	4.1	4.3	4.6	4.7	5.0	5.3	5.7	6.1	6.4
<i>c.c.</i>	0.5	0.3	0.3	0.2	0.2	0.2	0.55	1.25	3.2	4.0	4.85	4.9

The retention of the silver by gelatin at a pH > 4.7 is well shown by the fact that if test tubes containing samples of the various gelatins are exposed to light, those which are on the alkaline side of the isoelectric point blacken, whereas those on the acid side do not, but remain transparent even when exposed to light for months.

Results similar to those with silver nitrate are obtained when a nickel or copper salt is used. With potassium ferrocyanide the gelatin should retain the ferrocyanide, as gelatin ferrocyanide, on the acid side of the isoelectric point, and this is found to be the case.

Results such as the above indicate the necessity of knowing the pH when any investigations are carried out, and also of making comparisons of any particular property at the same pH. When such comparisons are made, Loeb has shown that the Hofmeister series, with their anomalies, disappear; for example, the various monobasic acids, and acids such as phosphoric, oxalic, and citric acids, which dissociate into two ions at ordinary dilutions, have the same effect on swelling, viscosity, etc., at the same pH. Dibasic acids, such as sulphuric acid, which dissociate into three ions at ordinary dilutions, should, and do, give different effects from the monobasic acids. Similar results were found with alkalis, and abnormal effects produced by such salts as sodium acetate were shown to be due to the alteration of the pH of the gelatin solutions when the salt was added.

The increased swelling, viscosity, etc., which take place on either side of the isoelectric point and reach a maximum at pH's of about 3.5 and 8.5 respectively, are attributed by Pauli to the greater hydration of the gelatin ions formed, as compared with that of the neutral molecule, but Loeb is not in agreement with this. The latter postulates the existence in any protein solution of molecularly dispersed particles, floating side by side with submicroscopic particles occluding water, the amount of which is regulated by the Donnan equilibrium (Procter was the first to apply the Donnan equilibrium to the study of gelatin solutions). The osmotic effects are determined by the molecular particles, the viscosity effects by the submicroscopic particles. Any influence in the solution (change in H-ion concentration) by which the molecular dispersion

is increased at the expense of the solid particles will result in an increase in the osmotic pressure and a decrease in viscosity, and the opposite conditions would result in the reverse of these effects.

The quantitative investigation of the physical properties of gelatin seems to have passed through three phases: in the first phase it was treated mainly as a colloid, in the second mainly as an amphoteric electrolyte, and now, in the third phase, as illustrated by Loeb's latest ideas, it is being realised that both its amphoteric and colloidal properties must be taken into account, since both play a part in its industrial applications. For example, its action as a protective colloid is of great importance in the preparation of photographic emulsions, but in the operations of developing and fixing its behaviour as an amphoteric substance must be considered, as may readily be realised when one remembers that the usual developers are alkaline, and that acid fixing baths are often used; the swelling of the gelatin film will vary in the baths, and in the change from the developer to the fixing

bath the gelatin must, at some time, pass through the isoelectric point.

The structure of gels has been a bone of contention for a long time. Nägeli assumed that gels were two-phased and that the solid phase was crystalline, but Scherrer has not found any indication of crystalline structure in gelatin when examined by the X-ray method. Bütschli and van Bemmelen have advocated a cell-like structure, forming a net-work, and Hardy concluded that the solid phase consists of a solid solution of water in gelatin and the liquid phase a solution of gelatin in water; Wo. Ostwald has put forward the idea of a two-phase liquid-liquid system. Procter postulates the existence of a solid solution of the exterior liquid in the colloid in which both constituents are within the range of the molecular attractions of the mass, and Loeb has extended this idea. At the present time the conception of a fibrillar structure, as advocated by McBain and his co-workers for soaps, is gaining ground and is especially supported by Bogue in America and Moeller in Germany.

### Current Topics and Events.

PROF. F. G. COKER was recently presented in London with the Howard N. Potts gold medal of the Franklin Institute of Philadelphia, awarded to him in recognition of his recent work on photo polarimetry. His method of determining stress in models of pieces and shapes made of homogeneous nitrocellulose material was brought to the attention of the Institute's committee on science and the arts in February 1921, and it was found that the General Electric Company of Schenectady, New York, had in use Prof. Coker's apparatus. A committee was appointed to investigate the apparatus and method, and it reported that Prof. Coker's work was in the highest degree worthy of recognition by the Institute on account of the ingenuity and experimental skill shown "in applying the principles of photo elastimetry to the study of the magnitude and distribution of strains in models of pieces and shapes under stress." The medal, with the accompanying certificate and report upon which the award was made, was presented to Prof. Coker at a dinner at the Savoy Hotel by Dr. R. B. Owens, secretary of the Franklin Institute.

SOME very remarkable achievements in gliding, or soaring flight, are described by the Berlin correspondent of the *Times* in the issue of August 21. The flights were made by two of the competitors in a test competition on the Wasserkuppe, near Fulda, for the grand prize for motorless sail-planes offered by the German Aeronautical Industrialists Union. On August 18 one of the competitors, Herr Martens, remained in the air forty-three minutes, cruised over the starting-place, and then flew due west, at an altitude of about 320 feet, a distance of ten kilometres, landing comfortably in a meadow near Weyhers. On the following day Herr Hentzen remained in the air about one hour forty-five minutes at an altitude varying between three hundred and

six hundred feet, then cruised to the starting-line and across country, landing also in Weyhers, near the spot where Herr Martens had landed the day before. His total time in the air was two hours and ten seconds. The wind was west-north-west, a moderate breeze with occasional gusts. It died away as he set off for the cross-country flight. The machine flown by Herr Martens was a monoplane, designed by the Science Section of the Hanover Technical High School, in conjunction with the Hanover Flying School. The *Times* correspondent gives the following details of its structure: span, 39.4 ft.; wind surface, 172.2 sq. ft.; surface pressure, 2.4 lb. to the sq. ft. The pilot sits directly under the plane. The controls are worked by both the hands and feet. Lilienthal's glider, the correspondent recalls, had a span of 23 ft. and a wind surface of 151 sq. ft.

WE learn from *Science* that from the list of applicants for the Bishop Museum fellowships Yale University has selected the following fellows for the year 1922-1923: Dr. H. W. Fowler, ichthyologist, Philadelphia Academy of Science; Dr. N. E. A. Hinds, instructor in geology, Harvard University; and Dr. Carl Skottsberg, director of the Botanical Garden, Göteborg, Sweden. Dr. Fowler will devote his attention to a study of the fish of Hawaiian waters; Dr. Hinds will continue his investigations of the geology of the island of Kauai; and Dr. Skottsberg proposes to make a study of the flora of Hawaii with particular reference to comparison with the plant life of Juan Fernandez and other islands of the south-east Pacific. The four Bishop Museum fellowships yielding one thousand dollars each were established in 1920 by a co-operative agreement between Yale University and the Bernice P. Bishop Museum of Honolulu. They are designed primarily for aid in research on problems in ethnology and natural history which involve field studies in the Pacific region.



ON September 18 to 24 will be held at Leipzig the Centennial Festival of the Gesellschaft Deutscher Naturforscher und Ärzte (Association of German Men of Science and Physicians). The meetings will be preceded by a series of lectures and demonstrations in scientific microscopy to be given at Leipzig University. At the festival an exhibition will be held and a number of papers read by leading German men of science. Among the latter are the following: "The Theory of Relativity in Physics," Dr. Einstein; "The Theory of Relativity in Philosophy," Dr. Schlick; "Restorative Surgery," Drs. Bier and Lexer; "A Century of Atavistic Research," Dr. Johannsen (Copenhagen); "External Phenomena and Atavism," Dr. Meisenheimer (Leipzig); and "The Theory of Human Atavism"; "Progress and Retrogression in the Course of the World's History"; "Germany's Climate"; "The Highlands of Tibet and their Inhabitants," by Dr. Sven Hedin. Following the festival will be a series of continuation courses in medicine to be given at Leipzig, while during the period of the meetings special theatrical performances and concerts are to be arranged. Any one interested in medicine or natural science may take part in the meetings for a fee of 100 marks (or a correspondingly higher fee in the case of foreign countries). Those who wish for further particulars should apply to the Association at Leipzig.

THE autumn meeting of the Institute of Metals will be held at Swansea on September 19-22. On the evening of the opening day the first annual lecture on subjects of practical interest to those engaged in the non-ferrous metals industry will be given by Dr. R. S. Hutton, on "The Science of Human Effort (Motion Study and Vocational Training)." There will be a number of social functions and visits to works, and the following are among the communications to be submitted: Sixth report to the Corrosion Research Committee on the Nature of Corrosive Action and the Function of Colloids in Corrosion, Dr. Guy D. Bengough and J. M. Stuart; report to the Aluminium Corrosion Research Sub-committee on Experiments on the Oxide Method of Determining Aluminium, J. E. Clennell; "Grain-size and Diffusion," Prof. J. H. Andrew and R. Higgins; "The Structure of Eutectics," F. L. Brady; "The Antimony-bismuth System," M. Cook; "The Effect of Superheated Steam on Non-ferrous Metals used in Locomotives," Sir Henry Fowler; "The Constitution and Age-hardening of Alloys of Aluminium with Copper, Magnesium, and Silicon in the Solid State," Marie L. V. Gayler; "Intermetallic Actions: the System Thallium-arsenic," Q. A. Mansuri; "The Effects of Overheating and Melting on Aluminium," Dr. W. Rosenhain and J. D. Grogan; and "The Copper-rich, Aluminium-copper Alloys," D. Stockdale.

THE programme arranged for the Engineering Section of the British Association at the Hull meeting is somewhat of a departure from those of recent years. Two mornings are to be devoted entirely to papers and discussions on single definite subjects, and every

effort has been made to arrange the programme in such a way that ample time will be available for discussion. The subject for Thursday, September 7, is "The Strength of Railway Bridges"—a vital topic at the present moment, when bridges are being subjected to loads very much in excess of those for which they were originally designed. Papers on the subject will be read by the engineers of some of the leading railway companies. On Friday, September 8, a descriptive paper will be read on "The Equipment of a Modern Portland Cement Works." The manufacture of cement is one of the leading local industries, and a visit will be paid to the new works of the Humber Portland Cement Co., which have been recently equipped on the most up-to-date lines. A paper of interest to the cement industry will be that on the effect of fire on reinforced concrete buildings. On Friday morning also the president, Prof. Hudson Beare, will give his presidential address on "Some Australian Railway Problems." Monday morning, September 11, will be devoted entirely to a discussion on "Economic Steam Production, with special reference to Marine Practice," and papers on the subject will be read by representatives of the Fuel Research Board, the Admiralty, and Messrs. Babcock and Wilcox. On Tuesday morning a paper on a closely allied and highly controversial subject, viz. "The Propelling Machinery of the Cargo Carrier of the Future," will be read by one of the leading engineers of Messrs. Beardmore and Co., who have done a great amount of work in developing the oil engine for this purpose. On Wednesday morning a paper on the resolution of compound stresses will be read and also one on electrical ignition apparatus for internal combustion engines, and a demonstration of the Collins micro-indicator for high-speed engines will be given. A number of afternoon visits to works and objects of engineering interest has also been arranged.

THE meetings of Section M (Agriculture) of the British Association at Hull are to be held under the presidency of The Rt. Hon. Lord Bledisloe, whose presidential address is to be on the subject of "The Proper Position of the Landowner in Relation to the Agricultural Industry." Following the practice introduced by Mr. Orwin last year, Lord Bledisloe will circulate his address and invite a discussion on his views. This will take place on September 11. In the programme of the section are three joint meetings and discussions with other sections. The first of these on the opening day—Thursday, September 7—is to be held at 11.30 A.M., and will be opened by Sir William Beveridge on the subject of "Weather Cycles in Relation to Agriculture and Industrial Fluctuations." This meeting is in association with Sections A and F (Mathematics and Physics, and Economics). Contributions have also been promised by Mr. Udney Yule and Mr. R. A. Fisher. On the following day a meeting will be held at 11.30 A.M. jointly with the Physiology Section to discuss the subject of Vitamins. This discussion will be opened by Prof. Drummond, and Messrs.

Golding, Orr, and Prof. T. B. Wood have promised to take part. The other joint discussion is also with the Economics Section, and should prove of wide interest, as the subject is "The Possibility of Increasing the Food Supply of the Nation." Sir John Russell, Sir T. H. Middleton, Mr. C. S. Orwin, and Prof. Somerville have promised to speak from the agricultural side. Sir A. Daniel Hall is reading a paper on "Land Reclamation on the East Coast," and an excursion to see natural and artificial warpland should be interesting in this connexion. Prof. T. B. Wood is contributing a paper embodying some of the results which have been obtained in the work at the Animal Nutrition Institute at Cambridge. Among other interesting papers are several dealing directly or indirectly with the use of lime in the improvement of soil conditions, and with the evaporation of water from soil. Horticulture and the nutrition of fruit trees will be dealt with by Mr. H. V. Taylor and Prof. B. T. P. Barker, and farm costs in Yorkshire by Dr. A. G. Ruston. In addition to the excursions already mentioned another has been arranged to enable members to see something of the farming of the Yorkshire Wolds, and it is also hoped to visit some of the oil-cake factories in Hull.

THE Toronto correspondent of the *Times* announces that the Quebec Government has decided to set aside about 22,000*l.* for the purpose of establishing a Radium Institute, under the control of the University of Montreal, for the experimental treatment of cancer.

ACCORDING to the Spanish journal *Iberica*, two underground railways are now in course of construction in Barcelona, viz. the Ramblas-Gracia, of a total length of 3400 metres, and the Puerto branch, 1800 metres in length. The two lines, which will be double-track systems, are of 1.435 metres gauge. The construction of the system will be a matter of some difficulty, as most of it will be underground tunnel-driving, although a certain part, serving traffic in the busiest part of the city, will be in the open. Little difficulty is experienced as regards water, because most of the ground through which the tunnels will be driven consists of a thick stratum of quaternary clay, superimposed in places by strata of hard limestone marl. The method of construction adopted is the Belgian system. The diameter of the tunnels on the straight will be 7 metres, and in curves, etc., 9.95 metres.

A CORRESPONDENT informs us that the admirable drawings referred to in a review of Messrs. Heron-Allen and Earland's report on Antarctic Foraminifera in *NATURE* of August 19, p. 241, were by Miss M. H. Brooks and not *Mr.* M. H. Brooks as therein stated.

THE Cambridge University Press promises for the autumn "The Air and its Ways," by Sir Napier Shaw. The volume will contain the Rede Lecture for 1921, and other contributions to meteorology, for schools and colleges.

### Our Astronomical Column.

COMETS.—A photograph of Skjellerup's Comet, 1922*b*, was obtained on July 31 at Greenwich: it confirms the short period, which appears to be very close to 5 years, thus making it definitely the second shortest cometary period. That of Encke's Comet is  $3\frac{1}{2}$  years, that of Tempel's Second Comet is  $5\frac{1}{2}$  years. The identity with Grigg's Comet, 1002 II, is rendered almost certain, since both the period and the other elements accord closely. The perihelion distance has increased considerably, but only by an amount comparable with that which has occurred in the case of the Comet Pons-Winnecke.

The *Journal des Observateurs* of August 15 contains a series of observations of Reid's Comet, 1922*a*, made at Santiago da Chili by Rosauro Castro. There are twenty-two days of observation, from February 6 to March 31. The places of the comparison stars are taken from the Perth Astrographic Catalogue. The comet was observed for 2½ months, so that there is ample material for deducing the orbit. As the later observations deviate considerably from Mr. Wood's ephemeris, there is some reason to suspect appreciable departure from a parabola.

M. Kamensky has made in *Astr. Nachr.* 5168 a very elaborate investigation of the perturbations of Wolf's Periodic Comet from 1884 to 1919, due to Venus, Earth, Mars, Jupiter, and Saturn. The comet was observed at five apparitions (1884, 1891, 1898, 1911, 1918), and the normal places are all closely satisfied by the final elements, the largest residual being 8".6. The perturbations during the above period have been small, the range of the mean daily motion being from  $518^{\circ}.4$  in 1898 to  $523^{\circ}.8$  in 1884, or 1 per cent. There is, however, a near approach to Jupiter in 1922, which is likely to produce notable

changes in the orbit, making it quite doubtful whether it will ever be seen again. M. Kamensky promises to investigate them. It is to be hoped that others will emulate him in similar researches on other periodic comets. Those of d'Arrest, Pons-Winnecke, and Tuttle are all in need of such work.

THE PROBLEM OF THREE BODIES.—It has long been recognised that the analytical solution of the general problem of three finite masses, moving under their mutual attraction, cannot be obtained in a form that is of practical utility. Something can, however, be learnt of the circumstances of motion, by studying particular cases by the method of mechanical quadratures. Researches of this kind are being pursued at Copenhagen Observatory under the direction of Prof. E. Strömgen. Some of the results were published in the Jubilee Number of *Astronomische Nachrichten*, and are now reprinted as a brochure. There are two cases of special interest where the masses are as 1, 2, 1, the largest being in the centre. The first is an approximation to an "orbit of ejection," and involves periodic near approaches. The outer masses describe curves resembling *limaçons* (without loops or cusps), while the central one describes a curve resembling the inverse of an ellipse with respect to the centre. The other case is an approximation to the case of the arrangement of the three masses at constant distances along a rotating straight line. When the conditions for the straight line are slightly departed from, each body describes a small loop; that of the central body is practically an ellipse with its major axis perpendicular to the rotating line. In each case the motion is periodic, and the curves repeat themselves indefinitely.

## Research Items.

**THE AGE OF STONEHENGE.**—In the August issue of *Man* Mr. E. Herbert Stone describes some astronomical enquiries into the midsummer sunrise at Stonehenge. The date, 1840 B.C., given here for midsummer sunrise in line with the axis of Stonehenge must, the writer says, be regarded merely as a rough approximation. Owing to want of precision in the data Sir Norman Lockyer considered that the error—plus or minus—might amount to as much as 200 years; that is to say, the actual date is probably not earlier than 2040 B.C., and not later than 1640 B.C.

**THE HULL MUNICIPAL MUSEUM.**—Mr. T. Sheppard-Curtor of the Hull Municipal Museum, has published a pamphlet giving an account of the collections under his charge. The museum originated in the collections of the museums of the Literary and Philosophical Society, which dates back to 1823. Eventually these collections were made over to the Hull Municipality, and the new museum, which has been improved by numerous gifts and purchases, was opened in 1902. It now contains numerous examples of the Prehistoric, Bronze, and Roman periods, and of the Anglo-Saxon, pre-Viking, and Viking ages, besides more modern productions. The Geological Gallery is an important feature of the institution, which seems to be efficiently conducted. The publication in a cheap form of monographs for the use of visitors is an important part of the work of the museum.

**THE FLORA OF THE DAKOTA SERIES.**—The Upper Cretaceous flora, so widely known as that of the Dakota Beds, is receiving detailed attention from C. Wilber Berry, who marks out successive stages in the southern states of N. America. His review of these in a paper on "The Flora of the Cheyenne Sandstone of Kansas" (U.S. Geol. Survey, Prof. Paper 129—1, 1922) shows that the term "Dakota flora" has been too vaguely used. The author has proved the Patapsco flora of Virginia and Maryland to be Albian. A comparison of genera gives the Cheyenne Sandstone a distinctly higher position, presumably Cenomanian, since the flora of the Woodbine Sand of Texas (*ibid.*, 129—G) is held to succeed it and to be Turonian rather than Cenomanian. The Woodbine flora is synchronous with that of the true Dakota Sandstone of the western interior, and floras older than this should not now be described as of Dakota age.

**DEVONIAN FOSSILS FROM CHITRAL AND THE PAMIRS.**—Dr. H. H. Hayden in the course of his journey through Chitral and the Pamirs in 1914 studied the geology and collected the fossils he came across. Of these the Devonian Invertebrata, chiefly Brachiopoda, have now been described and figured by F. R. Cowper Reed (Mem. Geol. Surv. India, New Series, vol. vi., mem. 2). His investigations go to show that in Chitral the Upper Devonian is developed with a fauna of a west European type indicating a Frasnian age; the presence of the Middle Devonian is not proved, but the Lower Devonian is believed to be present. In the Pamirs the Upper Devonian fauna presents a different facies and does not possess a single species in common with the Chitral beds, it is unlike that of any beds of western Europe, but on the other hand, especially as regards the Brachiopoda, is characterised by a certain American element. Beds of Middle Devonian age are also probably present in the Pamirs. As might be expected, a fair number of the species proved to be new and are accordingly named and illustrated on the sixteen accompanying plates, which are of unusual excellence.

**THE CRETACEOUS MARINE TRANSGRESSION IN THE AFRICAN REGION.**—The investigation by Dr. L. F. Spath (Annals of the Durban Museum, vol. 3, part 2,

August 1921) of Cretaceous ammonioidea from Pondoland assigns the strata from which they have been collected to upper stages, Turonian to Campanian. Prof. J. W. Gregory, however, has gathered from the other side of the continent, in Angola, evidence of Albian strata, and it may be concluded that a submergence of some extent took place before the widely recognised Cenomanian transgression. Dr. Spath, following on Mr. R. B. Newton's account of the brachiopods and molluscs, describes the ammonioids from Angola in a memoir in the Transactions of the Royal Society of Edinburgh, vol. 53, part 1, 1922, with handsome plates provided by the funds of the Carnegie Trust. Most of the 117 specimens were collected near Labito Bay, and not a single Cenomanian ammonite occurs among them. The fauna is compared with that of Albian horizons in Madagascar and India; but the author holds that its closest affinities are with that of the Mediterranean region. Similar relations have been indicated for the Cenomanian fauna of West Africa. The paper includes considerations affecting the classification of ammonioidea from the British Gault.

**MOUNT ETNA AND UPPER AIR CURRENTS.**—In a paper published by the Reale Accademia Nazionale dei Lincei (vol. xxxi, ser. 5a, fasc. 7, 1922), Prof. Filippo Eredia shows that numerous pilot balloon observations conducted at Catania confirm what had been revealed by cirrus clouds and smoke from the volcano, namely, that the upper wind is very persistently from the N.W., and that Mount Etna does not effect any local modification in the general course of the Temperate latitude westerlies, which have been shown by Hildebrandsson to acquire a northerly deviation at the higher levels. The balloon observations in question disclose a definite N.W. direction at all seasons at the height of about 2400 metres (7000 feet *circa*), this direction becoming very persistent at 3300 metres (10,000 feet). It is found that the increase in the speed of the wind with altitude is in the Etna region more pronounced in summer than in winter, and the fact is connected with the greater rotation of the direction of the wind with height in summer, the surface winds in winter being also W. or N.W. The N.W. upper current is styled "il contro-aliseo boreale," that is, the northern counter (anti) trade feeding the tropical high pressure, in accordance with the terminology of Hildebrandsson.

**BRAZILIAN CLIMATOLOGY.**—An official publication ("Boletim de Normaes, Ministerio da Agricultura, etc., Directoria de Meteorologia"), under the direction of Sampaio Ferraz, has recently appeared, comprising meteorological statistics for a large network of stations scattered over the republic of Brazil, so that, although the records cover but a few years, it is evident that a commencement has been made towards a very thorough climatological survey of this remarkably progressive tropical state. For the capital, however, Rio de Janeiro, situated in lat. 23° S., near the southern tropic, a thirty years' record or more exists for most of the meteorological elements, and it may be of interest to quote a few figures. The annual range of mean temperature is what one would expect in a maritime city at the margin of the tropics, namely, about 10° F. between 77°·3 F. in January and 68°·1 F. in July, the figure for the year being 73°·6. The absolute maximum is 102°·2 recorded in December, and the absolute minimum for the period 50°·3 in September. Thus frost, which is often quite severe in the extreme south of the republic, has not been recorded in the capital by a wide margin. The mean annual rainfall is 46 inches, with a summer maximum, and the greatest 24-hour fall of 8·9 inches is in no way remark-

able for a hot country, this amount having actually been exceeded in England. The mean annual evaporation exceeds the rainfall by 1 inch—a balance fairly typical of this type of climate. Rain falls on 136 days, and thunderstorms occur on as many as 68 days. The mean annual humidity is 78.3 per cent., with little monthly variation, whilst the vapour tension follows closely the monthly mean temperature. The general subject of the geographical and seasonal variation of absolute humidity is deserving of more study, but it seems almost inevitable that, except perhaps in arid continental interiors away from sources of vapour supply, the dominating factor controlling the variations must be temperature.

**CURRENT METERS.**—A pamphlet by Dr. M. A. Hogan on "Current Meters for use in River Gauging" has been issued by the Department of Scientific and Industrial Research for the committee on gauging rivers and tidal currents (London: H.M. Stationery Office, 1s. 6d. net). The pamphlet gives in vi + 33 pp. a useful summary of information relating to the conditions affecting the design and use of current meters. Several meters in common use are described, and sections are devoted to a discussion of the effects of oblique and varying velocities, and also of turbulence. Theoretically, the best type of meter is the screw type fixed on a rod, with blades or guard rings specially designed for the good measurement of oblique velocities. But the main disadvantages attached to this type of meter concern the practical details, such as the supporting of the rod during measurement, and in this respect it is concluded that the cup-type meter, being supported by a cable, is more easily manipulated. The results of tests of meters in turbulent water and also for low velocities are collated. The author concludes that in favourable circumstances most meters will give results of sufficient accuracy for river gauging, but that when the conditions are unfavourable, as when turbulence is present, the crude results given by a single meter of any existing type are likely to be considerably in error. The most important effects of turbulence arise through the variations in direction of velocity rather than in magnitude. With the cup type of meter turbulence causes over-registration, while with the screw-type meter it causes under-registration, so that a combination of the two types can be used to measure turbulent flow.

**TELESCOPES VERSUS FIELD GLASSES.**—Although almost every text-book which deals with optical instruments describes the astronomical or Kepler and the Galilean telescopes, and explains how the former may be converted into an erecting telescope like the latter, few of them direct attention to the decrease of luminosity of the field due to the erecting devices, and still fewer give any information as to the relative extents of the fields of view of the two instruments. It is, however, on account of the small field of the Galilean instrument that it is no longer used in astronomical observatories, and some explanation of this restriction of the field should be given in any modern text-book on optics. To fill the gap in present-day text-books Dr. A. Sonnefeld, of Jena, contributes an article on the subject to the issue of *Die Naturwissenschaften* for July 28. From the point of view of the instrument-maker wishing to widen the field, the subject has been treated recently by Messrs. Hughes and Everitt, *Transactions of the Optical Society*, 22, p. 15, and by Mr. T. Smith in the same volume, p. 84.

**SPECTRA ON THE QUANTUM-ORBIT THEORY.**—This theory has been so successful in describing the known facts as to the spectra of elements constituted of a single nucleus and a single electron, that there is considerable justification in the hope that it may

help to explain the spectra of more complicated elements. An approximate solution of the larger problem has been given by Sommerfeld in his "Atombau und Spektrallinien," but there are assumptions made by him as to actual spectral observations which Prof. Hicks points out in a paper on the subject in the August issue of the *Philosophical Magazine* are not justified. In the first instance the expression for the frequencies of the lines of a series which results from taking the atom to consist of a central nucleus, a ring of equally spaced electrons and outside it a single electron obeying the quantum laws, is not general enough to cover all known series. In the second instance observation lends no support to Sommerfeld's deduction that the different types of spectra are obtained by giving one of his constants successive integral values. Lastly, many small and often irrelevant points are referred to as striking confirmations of the theory, which, when examined more carefully, are found to afford no support to it.

**HEXOSAMINES AND MUCINS.**—Dr. P. A. Levene, in Monograph No. 18 of the Rockefeller Institute, gives the interesting results of his work on constitution of these substances. He shows that the nitrogen in the amino-sugars is present as a primary amino group, in analogy with the other glucosides. A large number of derivatives are described and many of the hexosamines were synthesised. As regards the mucins, it is shown that there are two groups, from one of which chondroitin-sulphuric acid is obtained, from the other mucicottin-sulphuric acid. They differ in the fact that the former, obtained from cartilage, aorta, and sclerotic, contains the amino-hexose, chondrosamine; the latter, obtained from umbilical cord, vitreous humour, and cornea, contains in its place chitosamine. This latter amino-sugar is sometimes called glucosamine. The chitosaminic acid derived from it turns out to be 2-amino-mannonic acid, whereas chondrosaminic acid is 2-amino-talonic acid. Apart from this difference, the two conjugated sulphuric acids are similar and consist of the amino-hexose, glucuronic, acetic, and sulphuric acids in equi-molecular proportions. The amino-sugar and glucuronic acid are combined as a disaccharide. The acetyl group is linked to the amino group. Finally two molecules of the whole are joined as glucoside by their glucuronic acids. There appears to be a slight difference in the place of attachment of the sulphuric acid to the amino-sugar.

**THE COMPOSITION OF PHOSPHORITE.**—Mr. A. F. Rogers (*Amer. Journ. Sci.*, vol. 203, p. 269, April 1922) writes of "Collophane, a much neglected mineral," and shows that this name deserves a more general recognition. It was given by Fridolin Sander in 1870 to an amorphous calcium phosphate and carbonate, with some water, from Sombrore. Sander eliminated the carbonate; but the material has been shown by Lacroix to consist almost exactly of  $3\text{Ca}_3(\text{PO}_4)_2 \cdot \text{CaCO}_3$ . Dahllite is clearly its crystallised representative. The author regards the variations in composition as due to solid solution, calcium fluoride and sulphate being sometimes concerned. Collophane becomes important if we recognise that a large part of the ordinary phosphorite of commerce, rock-phosphate and the rest, consists of this material. When the author states that, "like most other amorphous minerals, it is of colloidal origin," he probably means that it once was in a colloidal state. Dahllite has, of course, been previously recognised as forming the concretions of phosphorite in Podolia, which show internal radial crystallisation. Carbon dioxide varying from 2.40 to 11.72 per cent. is recorded by J. Samojlov (*Compte rendu Congr. internat. géol.*, 12<sup>mo</sup> session, Canada, 1913, p. 850) as a constituent of the widely spread Jurassic and Cretaceous phosphorites of Russia.

## The Glasgow Meeting of the British Medical Association.

THE ninetieth annual meeting of the British Medical Association was held in Glasgow on July 25-28, under the presidency of Sir William Macewen, and its proceedings included much of interest to men of science outside the circles of medical specialism. In his address delivered on the evening of July 25 in the Butte Hall of the University, after welcoming the Association to Glasgow and referring to some of the great names associated with the University of Glasgow during the 471 years of its existence, the president put in a strong plea for a broader scientific outlook with less concentration on purely human phenomena. He referred to the want of scientific training and scientific habits of thought in the general community, and pointed out how this had led to the neglect of discoveries of the greatest practical importance. It had now been discovered that such a disease as syphilis was a preventable germ disease, which could be stamped out by means made known to them: "If this generation did not stop the disease it committed a crime against posterity." The main part of the address dealt with the enthralling subject of brain-surgery, of which the speaker is one of the most distinguished pioneers, and of which he is still an acknowledged master.

On the following three days the Association met in separate sections, housed in the medical and scientific departments of the University, and in various of these papers were read and discussions held which were of wide scientific importance. In the section of pathology an interesting discussion took place on "Animal and Vegetable Pathology in Relation to Human Disease," the openers being Prof. Hobday and Prof. Lang. The former dealt mainly with the importance of diseases communicable to man, such as glanders, rabies, anthrax, and tubercle. Prof. Lang discussed in a more general way the relations of vegetable pathology to animal, tending on the whole to sound a note of caution against the assumption that the principles underlying the processes of disease and healing are identical in the two kingdoms. He discussed the case of crown gall, on which important recent work had been done by Smith and Townsend, and by Robinson and Walkden. In this case tumours developed in relation to wounds such as those made in grafting, and it had been shown that the new growth was due to infection by a specific microbe *Bacterium tumefaciens*. The fundamental differences in organisation between the higher animal and the higher plant should, in Prof. Lang's opinion, be carefully borne in mind before instituting close comparisons between such tumours caused by *B. tumefaciens* and the malignant new growths of man. The probability was that the pathogenic processes of plants and animals had begun to diverge from one another at a very remote period of evolutionary time, and the value of the study of plant pathology to the human pathologist (and incidentally to the student of medicine) lay rather in its broadening the outlook than in its providing the bases for direct inferences from one subject to the other. In the course of his paper Prof. Lang referred to the fact that the study of ancient plants obtained from the Old Red Sandstone of Scotland had disclosed injuries, due apparently to irritating gases, and healing processes, bearing the closest similarity to what may be observed in modern plants after exposing them to irritating vapour. This fact is obviously of extraordinary biological interest as being the most ancient case of histological reaction which has been subjected to histological investigation.

The discussion just mentioned had its supplement

on the following day in the new but highly successful section of micro-biology, sitting under the presidency of Dr. R. M. Buchanan, when Prof. V. H. Blackman opened a discussion on "Some Similarities and Dissimilarities in the Micro-biology of Plant and Animal Diseases." Prof. Blackman also was inclined to emphasise the differences rather than the resemblances between the diseases of plants and animals. He gave an interesting general review of the relations of parasite and host in the parasitic diseases of plants. The immunity of plants towards hostile micro-organisms was a natural immunity: the acquired immunity so characteristic of many human diseases and forming the basis of modern serum-therapy was quite unknown in relation to specific diseases in plants. Immunity was often of a passive kind, such as is provided by a resistant cuticle or cell-wall, successful invaders in such cases making their way in through natural openings such as the stomata, or through special perforations made by their own activity. In other cases the immunity was of an active kind, involving a distinct physiological reaction on the part of the plant. Thus in cereals immune to "rust" the cells have developed a hyper-sensitive to the proximity of the fungus, dying upon its approach, before they can be penetrated by the parasite. In other cases the host imprisons the invading parasite in an envelope of impermeable cork cells. Prof. Blackman also directed attention to the existence amongst plants of diseases due to so-called ultra-microscopic organisms. Two diseases of this type occurring in the potato had recently been found to show a further analogy with diseases of a similar type occurring in animals in that they were insect-borne, being transmitted by aphides or green-fly.

The "ultra-microscopic" or "filter-passing" organisms were also to the fore at other meetings of the section of micro-biology. On Wednesday, July 26, Dr. F. d'Herelle, of the Pasteur Institute, opened a discussion on his theory of "Bacteriophage"—a theory formulated to explain the fact that among the contents of the alimentary canal there always exists a "something" which possesses the power of dissolving bacteria of certain definite types, e.g. in the case of man bacteria of the coli-typhoid-dysentery group. This "something," sometimes called an enzyme, sometimes given the more definite name bacteriolyisin, is of uncertain origin. The balance of probability would probably appear to most biologists to be in favour of its being formed by the activity of the host, its formation being part of the general defensive mechanism of the body. Dr. d'Herelle, however, believes it to be formed by an ultra-microscopic enemy of the bacteria, which he names *Bacteriophagum intestinale*, and he supports his theory by a mass of striking arguments. Dr. Twort, of the Brown Institute, gave an account of his earlier work, in which he determined the existence of a similar bacteriolytic substance in cultures of *micrococcus*. A point of much interest emphasised by Dr. Twort, but usually ignored by biologists, is the probability that ultra-microscopic organisms exist in abundance free in nature, and are not confined to a parasitic existence.

In the discussion on Thursday, July 27, upon the "Bacteriology of Influenza," an important rôle was again assigned to the ultra-microscopic type of organism. Dr. Mervyn Gordon recalled that a large number of diseases, such as measles, mumps, small-pox, were now attributed to these organisms, measuring under  $0.5\mu$  in diameter, to which Prowazek had given the name Chlamydozoa. Strong evidence had recently been adduced that the real causative agent

of common cold was an organism of this type, measuring 0.2-0.3 $\mu$  in diameter. Dr. Gordon gave an account of his recent researches, which are entirely confirmatory of the view that influenza is similarly due to organisms of this type, which can be obtained from the nasal and pharyngeal secretion during the first three days of the disease, though not later.

The section of physiology met on two days only, each being taken up mainly with an interesting discussion. The first, on the "Etiology of Rickets," opened by Dr. Leonard Findlay and Prof. Mellanby, was mainly of medical interest, but it left two distinct impressions on the lay mind: (1) That there is still much difference of opinion in regard to the cause of this blot on the health of our great cities, and perhaps too great a tendency to the belief that one single factor is responsible rather than a complex of factors; and (2) A strong impression of the valuable return which is bound to accrue to the community through the activities of the Medical Research Council under the guidance of its present secretary.

The other discussion in this section had for its subject "Basal Metabolism," *i.e.* the metabolism during complete rest. In his interesting opening address Prof. Cathcart incidentally emphasised the extreme complexity and elusiveness of the phenomena grouped under that blessed word metabolism—facts which are liable to be accorded insufficient weight by biological writers and teachers.

One of the most important features of the Glasgow meeting was the discussion which took place on Friday morning, July 28, in the section of medical sociology upon "Alcohol as a Beverage in its relation to certain Social Problems"—a discussion which stood out in strong relief from most discussions on this much discussed subject from its including moderate and calmly reasoned statements from scientific investigations of recognised status. The discussion was opened with an admirable introductory statement by Prof. Mellanby, of Sheffield, in which he laid down the basic facts regarding the physiological action of alcohol. As a drug it was to be regarded as a narcotic, acting on the cells of the cerebral cortex and slackening its control and discipline over the lower nerve centres. It was as a narcotic drug that alcohol in small doses found its usefulness in human life, dispersing temporarily worries and troubles, and so facilitating bodily functions that were known to be interfered with by anxiety. As a food the value of alcohol in moderate amounts rested on the fact that it is rapidly absorbed and to the extent of about 98 per cent. oxidised so as to set free heat. Experiment showed that as much as 40 per cent. of the heat lost from the body during a given period could be supplied by alcohol, but the practical utility of this was to a great extent neutralised by the poisonous drug action. Under abnormal conditions, however, such as those of Diabetes mellitus, the food value of alcohol in small doses could be utilised to take the place of sugar. Dr. J. T. MacCurdy, of Cornell, speaking as a psychiatrist, emphasised the fact that "the Alcoholic is, before he ever touches a drop, an abnormal person," and also emphasised the great difficulty in carrying out a just

comparison between the two evils of such abnormality finding expression in alcoholism or in some other form of vice or crime. From the purely scientific point of view one of the most interesting contributions to the debate was that from Prof. C. R. Stockard, of Cornell Medical College, which told of his experiments, extending over a long series of years, on the influence of alcohol in causing abnormalities of developing eggs and embryos. His experiments on mammals (Guinea-pig) were of particular interest in demonstrating how heavily dosing the parents with alcohol produces marked effects in diminishing fertility, in increasing pre-natal and early post-natal mortality, and in causing defectiveness of the offspring. If we are justified, as no doubt we are, in extending Stockard's results to man, we are afforded incidentally a fine illustration of natural selection at work in the civilised community—for these individuals that are afflicted with the particular form of "unfitness" that finds its superficial expression in drunkenness are seen to be subjected to a severe process of weeding-out during foetal and infantile life which works in the direction of keeping up the standard of the surviving stock.

It must not be thought that the proceedings of the sections exhausted the activities of the meeting. An admirable "Museum" was got together by Prof. Teacher, while Dr. Dunkerly arranged a microbiological exhibition, which included beautiful series of Leishmania and of Spirochaetes exhibited by Sir Wm. Leishman, and Dr. Connal's series of developmental stages of *Loa loa* in the body of the transmitting fly. Numerous interesting demonstrations were given at the afternoon meetings of the various sections, and the meetings concluded on Friday evening, July 28, with the "popular" lecture—entitled "The Physician—Naturalist, Teacher, Benefactor"—delivered to a large audience by Prof. Graham Kerr.

The gold medal of the Association was presented to the Right Hon. Sir. T. Clifford Allbutt and to Lieut.-Col. A. Martin-Leake at the general meeting on the evening of July 25. The presentations were made by the president on behalf of the association. The medal for distinguished merit was instituted by the association at its annual meeting in Manchester in 1877. The medal is awarded on the recommendation of the Council to some person who shall have conspicuously raised the character of the medical profession by scientific work, by extraordinary professional services, or by special services rendered to the association. On this occasion the medal was in each case accompanied by a testimonial or address stating the grounds of the award.

The Stewart Prize of the Association was presented to Dr. J. C. McVail at the same meeting on July 25. The prize was founded by the late Dr. Alexander Patrick Stewart, who was among the earliest to give attention to sanitary questions and also to distinguish between typhus and typhoid fever. The primary object of the Stewart Prize is to afford recognition of important work already done or of researches instituted and promising good results regarding the origin, spread, and prevention of epidemic diseases.

### Broadcasting in America.

MR. A. P. M. FLEMING, manager of the research and education departments of the Metropolitan-Vickers Electrical Co., Ltd., who has been closely identified with the development of radio broadcasting in Great Britain, recently attended a conference of the American Institute of Electrical Engineers at Niagara Falls as a representative of the

British Institution of Electrical Engineers and the British National Committee of the International Electrotechnical Commission. He took advantage of the opportunity while in America to make a close investigation of the position of radio telephony extending over a period of two months, and, in addition, studied the trend of public taste and opinion

with regard to broadcasting and the steps which are being taken by the Government to control radio transmission. He tested a wide variety of makes of receiving apparatus and discussed the methods of working, cost and organisation of broadcasting stations, and obtained a considerable amount of valuable experience which will assist in enabling British manufacturers to avoid the pitfalls into which many American firms have fallen. Mr. Fleming also visited the largest broadcasting stations and discussed the situation with the leading makers, radio engineers and officials.

Since the end of 1920 the broadcasting position in America has been chaotic. Practically anybody—private companies, municipalities, departmental stores, universities, Government offices, newspapers—have been able to set up transmitting stations, the only restrictions being the wave-length, 360 metres, and the power, about  $\frac{1}{4}$  kw. At the present time there are nearly five hundred broadcasting stations in the United States working without reference to each other, except in a few cases of friendly co-operation, with regard to time of operation, type of programme and object of the station. The stations are concentrated chiefly along the eastern states and on the Pacific slope, and no less than twenty stations are in close proximity to New York City. Broadcasting programmes are announced in advance through the press, and much use is made of gramophone records for transmission. The U.S. Government called a conference of interested parties at Washington a few months ago under the chairmanship of Mr. Herbert Hoover, and appropriate working conditions were decided. The passage of a Bill now before Congress will afford the Secretary of the Department of Commerce considerable powers to control and co-ordinate the radio traffic, including broadcasting. The process, however, at this stage is slow, and some time must elapse before the American system is giving the public as efficient service as it is hoped the British system will give from its inception.

The action of the Postmaster-General in restricting broadcasting is viewed with much approval in the States, as affording the most convenient means whereby confusion may be avoided.

During his visit Mr. Fleming saw the principal broadcasting stations in operation, including East Pittsburgh (call sign KDKA), Newark (WJZ), Chicago (KYW), Springfield (WPZ), all operated by the Westinghouse Co., the Detroit Free Press, Detroit News, Federal Telegraph and Telephone Co., Rochester School of Music, etc. From the two Detroit stations, as well as those at Pittsburgh and Chicago, Mr. Fleming broadcasted for the benefit of American listeners the position of radio telephony in Great Britain.

The broadcasting station comprises studios in which the artistes play and sing, transmission rooms, control rooms, green room and offices. Every station differs from others, all being in an experimental stage of development, and each one has points of interest which can be incorporated into English practice. It is estimated that two million radio receiving sets are in use, and during the last two years about 12,500 companies have been incorporated for carrying on radio business. Many of these, however, are mushroom affairs, against which the public has been warned.

The pioneer work in the development of broadcasting was conducted by the Westinghouse Co., of Pittsburgh, which opened station KDKA in December 1920. The Company also immediately placed upon the market a number of receiving sets and a remarkable demand arose. The whole country responded to this new form of entertainment, and the demand created has no parallel in recent years.

The patent situation with regard to radio apparatus, circuits and valves was so obscure and complicated that many of the leading makers might unwittingly have infringed each other's patents, and the pooling of the patents by the principal manufacturers has eased what might have been an extremely difficult situation. The Radio Corporation, a group of radio manufacturers already in existence and interested in communication by radio telephony, was utilised to act as a selling agent. There are, of course, many manufacturers outside this group, but small makers are not permitted to utilise patents for which they are not licensed, their sets consequently being less effective and up-to-date than those of the leading makers. Clearly the "mushroom" companies are unable to indemnify their clients against actions which may take place if basic patents are infringed by the apparatus they make.

One of the most interesting organisations in the States is the American Relay League, a national non-commercial association of radio amateurs who combine to relay friendly messages between amateur stations across the Continent and to protect the interests of amateurs. In this way messages from amateur transmitting stations can be sent over very much longer distances. Under British conditions such work is not possible, as those who hold 10-watt transmitting licenses can only send out messages connected with the experimental work for which their license is primarily intended, but attempts are being made to modify these restrictions. Amateur transmission could not, of course, take place while broadcasting is in progress.

During the hot summer months in America the public is not particularly keen on indoor entertainment, and noises in the receiving set due to atmospheric electrical disturbances are troublesome. The public taste is also changing, and those who have experienced reception last winter are developing a taste for more serious and solid matter than has hitherto been the case. Educational matter and health talks are becoming increasingly popular in programmes. More and more church services are broadcasted, and the improvement in the quality of sermons is helping to fill churches which have hitherto been very thinly attended. Market and stock reports are also sent out, and these are of great importance to farmers, *e.g.* the ruling price of pork in Chicago, obtained by radio, may help a farmer to decide whether to send his hogs to market or not immediately. University extensions and extra-mural lectures are being broadcasted to an increasing extent, and invalids and others ("shut-ins") who are unable to seek entertainment out of doors find radio a great boon.

There is no doubt that radio has come to stay. Its character will change, both through technical improvements and through changes in the public taste, but it is rapidly becoming a permanent part of the national life. It is being used to an increasing extent to send out what is known as "perishable news," to relieve the load on the ordinary telephone and telegraph lines. In this respect the attitude of the press has undergone a notable change. From opposition it has changed to whole-hearted support. Newspapers publish programmes at length, and have radio columns in which expert advice is given to amateurs.

Mr. Fleming is most optimistic as to the future of radio in Great Britain. While British audiences are likely to be more critical than American, with the aid of all that American experience has to offer British broadcasting will establish itself as the best in the world, and the public will find in it a unique and continuous source of entertainment and instruction, full of possibilities of expansion. The develop-

ments which are taking place even now in America are likely to produce far-reaching changes, such as the so-called wired wireless, by which radio trans-

mission is conducted for part of its path by an ordinary wired line. What these developments do, however, must be left for the future to determine.

### Third International Congress of the History of Medicine.

THE papers read at this Congress, which was held in London on July 17-22 under the presidency of Dr. Charles Singer, may be classified in four main groups according to their subjects, viz., epidemiology, anatomy, pharmacy, and veterinary medicine. Among the papers on epidemiology special mention may be made of those by Prof. Jeanselme, on bubonic plague in the Middle Ages, in which a relationship between famine and plague was shown; by Dr. Ernest Wickersheimer on the black plague at Strasbourg in 1349, with extracts from a contemporary document; by Miss M. Buer on the decrease of epidemic diseases in the 18th and early 19th centuries, a decrease attributed by her to improvements in agriculture, improvements in house and town planning and the advance in medicine; and an interesting account by Sir William Collins of Sir Edwin Chadwick, the father of English sanitary science. Other papers of epidemiological interest were those of Dr. Torkomian of Constantinople on inoculation against small-pox by the ancient Armenians, of Dr. Belohlavek of Prague on epidemics in Bohemia in the Middle Ages, and of Dr. Neveu of Paris on plague in Tuscany in the fifteenth century.

Perhaps the most interesting contribution to the history of anatomy was the paper of Prof. Wright on Leonardo da Vinci's work on the structure of the heart, in which it was stated that Leonardo was the first to show the exact attachment of the chordæ tendineæ to the cusps of the auriculo-ventricular valves, the first to direct attention to the dilatations of the origins of the aorta and pulmonary valves, the first to note the occasional presence of an inter-auricular foramen or foramen ovale, and the first to describe the moderator band in the right ventricle of the heart. Dr. Donald Campbell made a communication on the significance of the Arabic MSS. of Galen's work on anatomical administration, in which he suggested that the preservation of this work when portions of it were totally lost otherwise indicated that the Muslims did not completely destroy the second library of Alexandria, as is generally supposed. In a paper on the anatomical studies of Descartes in Holland, M. Fosseyeux showed by extracts from contemporary literature that Descartes, who was the grandson and great grandson of medical men, studied anatomy both in the human subject and in animals at Amsterdam, Utrecht, Leyden, and Harlem between the years 1630 and 1638. Other anatomical papers were those by Dr. T. Wilson Parry on the collective evidence of rephination of the human skull in Great Britain during prehistoric times, by Dr. Kathleen Lander on women as anatomists, by Dr. Krumbhaar of Philadelphia on the beginnings of anatomical instruction in the United States, and by Dr. J. D. Comrie on early anatomical instruction in Edinburgh.

In an historical sketch of pharmacy in Great Britain and Ireland, Mr. J. B. Gilmour showed that it was not until the 16th century that any beginning was made with the regulation of the practice of medicine or the sale of drugs, and even down to the 18th century the sale and dispensing of drugs was chiefly in the hands of the physicians and apothecaries. The paper deals successively with the evolution of the pharmacist, the history of pharmacy law, the origin of the Pharmaceutical Society of Great

Britain, pharmaceutical education and science, the protection of professional interests, pharmacy in Ireland, and the history of pharmacopœias and pharmaceutical literature. In his paper on art in the Italian pharmacy of the 15th century Prof. Castiglioni of Trieste stated that at the beginning of the 15th century the practice of medicine was closely associated with that of the apothecary, so that the druggist's shop was often an intellectual centre which served not only as a consulting-room for the doctor but also as a place where books and curiosities were exhibited. Prof. Castiglioni showed a large number of photographs of pharmacy jars from his private collection, illustrating the development of medicine in the 15th century. Mr. C. J. S. Thompson traced the history of "Hiera Picra," a remedy composed mainly of aloes and colocynth, which was first used, according to tradition, in the temples of Æsculapius in Greece and is still sold in the pharmacies of Great Britain and the Continent. M. Buchet contributed a paper on the history of legislation concerning poisons, and M. Fialon described the ancient statutes of the apothecaries of Lyons.

Major-General Sir Frederick Smith gave an interesting description, illustrated by lantern slides, of the position of veterinary anatomy in England during the 16th, 17th, and 18th centuries, in which he emphasised the following points: (1) The comparative absence of information on the subject, in spite of the fact that up to the 15th century practically only the anatomy of animals was studied by students of human medicine. (2) The interest shown by lay writers on a subject in which they were ignorant, but the importance of which in the advancement of veterinary knowledge they fully recognised. These men wrote on the subject and drew on their imagination. (3) The absence of any veterinary school in this country until the end of the 18th century, when one was founded in 1791 with Vial de Sabel as professor. Prof. F. J. Cole of Reading read a paper on Ruini on the anatomy of the horse, a work which, published in 1598, was the first monograph on the anatomy of an animal. Other papers on veterinary medicine were read by Mr. F. E. Bullock on "Mulomedicina Chironis," a compilation of ancient veterinary treatises; by M. H. J. Sevilla on the syndrome of colic in the Greek Hippiatric writings, and by M. Moulé on the history of glanders in Greek and Roman writers.

In addition to the papers on the history of epidemiology, anatomy, pharmacy, and veterinary medicine, communications on various topics of medico-historical interest were read. In a paper entitled "Magistri Salernitani nondum cogniti," Dr. Capparoni of Rome gave an account of a manuscript which he had found in the cathedral of St. Matthew at Salerno, containing the names of thirty-one hitherto unknown medical men from the second half of the tenth to the sixteenth century, most of whom were monks or ecclesiastics of some kind. This discovery confirmed Dr. Capparoni's view that scientific medicine at this period was mainly practised by monks until the papal prohibition in the 12th century to practise medicine outside the cloisters, with the result that the school of Salerno was founded by laymen. In a paper on Dante and Averrhoism in Italy, Prof. Castiglioni discussed the relations of



Dante with medicine. Though opposed to the view that Dante himself was a medical man, the professor stated that the poet studied medicine at Bologna, was closely connected with Alderotti and Pietro d'Albano, two of the most distinguished physicians of that time, was prior of the corporation of physicians and apothecaries, and was given the title of magister in a contemporary document.

Other papers on miscellaneous topics were those by Dr. F. J. Poynton on doctors and the dawn of aerostatics, by Dr. J. D. van Gils of the Hague on the doctors of Molière and Shaw, and by Mme. Panayotatou of Alexandria on hygiene and dancing in ancient Greece. It is proposed to hold the next Congress of the history of medicine at Geneva in 1925.

### The Research Association of British Rubber and Tyre Manufacturers.

PROBABLY in no industry is the old ground of knowledge less thoroughly explored and the new unbroken field for useful research so extensive and attractive as in the rubber industry taken as a whole. A hundred years or a little more have passed since the discovery that rubber could be converted into a workable form by solution in suitable solvents or by mechanical kneading, and the process of vulcanisation was discovered eighty years ago. These operations, which are yet applied unaltered in principle and very little different in practical detail, still represent the foundation of rubber manufacture of the present day; compared with them, all the other innovations have been of minor importance. The disadvantages, however, inherent to these fundamental operations are so marked as to cause surprise that so little further advance has been made during the last half-century. It is almost astounding that so large a portion of the effective history of the industry should be found recorded in the remarkable "Personal Narrative" of Thomas Hancock, published in 1857, after his retirement.

If anything further had been needed to emphasise the importance of the rubber industry, particularly that section of it dealing with the production of rubber tyres for various types of vehicles, and the call for its further scientific development, the period between 1914 and 1918 supplied the necessary stress in an unmistakable manner. It was natural, therefore, that members of certain companies interested in the manufacture of rubber goods should decide to take advantage of the assistance offered by Government to found a Research Association of British Rubber and Tyre Manufacturers. An energetic Committee under the chairmanship of Mr. Alexander Johnson saw the Association pass from the embryo stage to a state of healthy and vigorous existence with Mr. B. D. Porritt as director of Research.

On account of the early part of the year 1920 being inopportune for the purchase of premises and equipment, the Research Association first found a temporary home in University College, London, thus enabling a commencement with a preliminary, albeit necessarily restricted, programme of work, more particularly of a purely physical and chemical nature. Later, after careful search and inspection of suitable premises, purchase was completed of two detached houses at 105 and 107 Lansdowne Road, Croydon. These possessed several advantages, and after necessary alterations have been converted into a preprocessing unit. The space between the two houses is now occupied by a substantial connecting building which provides increased accommodation in addition to inter-communication. The frontage of

the site is 120 feet and the depth 206 feet, the latter leaving ample room for future extensions.

The building, which was formally opened by Lord Colwyn on July 26, comprises administrative offices, library, experimental laboratory for the preparation of rubber, incorporation of compounding ingredients and vulcanisation, workshop, mechanical testing laboratory, physical laboratory, chemical laboratories, storage accommodation and caretakers' quarters. All the necessary heavy experimental plant is contained in the basement of the inter-communicating building, and one of the two original houses has been kept entirely free from running machinery in order to permit the use of delicate instruments without risk of disturbance from vibration.

Those responsible for the founding of this Association have realised that the importance of research to industry lies not so much in the possibility of very occasional discoveries of a revolutionary nature as in the sure benefits which are the abundant fruit yielded by the application of science to the improvement of existing methods. The functions of the Association, while not excluding the study of fundamental problems, include more prosaic considerations such as improvement in the control of manufacturing operations and the testing of raw materials and final products. In such directions there is indeed urgent need for work, such vital matters as the reasons for the use and selection of various necessary "compounding ingredients" and the methods adopted for the production of vulcanised rubber possessing special physical properties, e.g. resistance to cutting or abrasion, resilience, toughness or even hardness, being based on almost entirely empirical grounds, often of the least desirable type.

Whatever requirement may have to be left unsatisfied in such an Association as this, it should be able to anticipate with the utmost confidence an abundant and unceasing supply of problems for investigation.

D. F. T.

### University and Educational Intelligence.

PROSPECTUSES of Universities and Colleges for 1922-23 are beginning to appear. Leeds University publishes an extensive programme of evening courses (advanced) in engineering, dyeing, textile and leather industries, and geology, and afternoon courses in coal-mining. During each of five evenings of the week from five to nine classes will be held. The faculty of engineering of the University of Bristol announces additional vacation courses to be held in 1923. University College, Exeter, is establishing new courses, intermediate and final, in horticulture and in agriculture, the final course in agriculture being at the Seale-Hayne Agricultural College, Newton Abbot.

SECONDARY education in the United States is, as every one knows, conducted chiefly in public (that is to say, in State) schools. But the part of the field occupied by the private high schools and academies is not inconsiderable. Advance sheets from the biennial survey of education in the United States, 1918-20 (Bulletin, 1922, No. 9 of the Bureau of Education), show that in 1919-20 there were 2093 of these institutions, attended by 184,153 secondary students and, in addition, 250,000 elementary pupils. A remarkable growth occurred between 1905 and 1920. During this period the number of their secondary students increased by 72 per cent. Nearly 75 per cent. of the institutions are under denominational control; of these 60 per cent. are Roman Catholic, and the following analysis shows that to the Roman Catholic schools is chiefly attributable the above-

mentioned increase in the number of secondary students in private schools. The increase was—in Roman Catholic schools from 20,150 to 76,054; in other denominational schools from 39,106 to 53,965; in non-sectarian schools from 47,951 to 54,134; in all from 107,207 to 184,153. The increase in the number of secondary students of negro race in private schools is also noteworthy—from 2774 in 1905 to 9526 in 1920. Less than half of the total number of these schools are co-educational, 385 being for boys only and 728 for girls only.

"WE should have a dynamic education to fit a dynamic world" is the burden of the address delivered by Dr. James Harvey Robinson, on "The Humanising of Knowledge," before the American Association for the Advancement of Science, at a meeting with the Pacific division in Salt Lake City on June 23-24. Once it was well to dehumanise science; now it must be rehumanised. Dr. Harvey thinks there is a real danger threatening the progress of science itself in neglecting the protest of philosophy, that the ideal of dehumanising scientific investigation loses sight of the fact that the onlooker is one of the essential elements in the observing and recording. The danger is not that the scientific ideal is faulty, but that mankind will not accept an idea unless it is attractive as well as true. "The politicians in the Kentucky legislature think themselves competent to decide whether the State should grant funds to any institution in which man's animal extraction is taught; the politicians in the New York legislature have provided that no one shall teach in the schools of the State who is known at any time to have expressed any distrust of our institutions." We on this side may smile at these fears; but after all it is well to be reminded that the scientific investigator is prone to take himself for granted and not to realise "what an altogether astonishing and even grotesque mystery he and his doings constitute" for the general mass of social human beings.

"CO-OPERATION and the Problem of Unemployment" is the title of a pamphlet issued last month by the Calcutta newspaper *Capital*, being a reprint of a series of articles contributed by Captain J. W. Petavel, Principal of Maharajah Kasimbazar's Polytechnic Institute, together with correspondence between Captain Petavel and the Vice-Chancellor of the Calcutta University. The recent establishment by this university of a Poverty Problem Study Fund, to meet the cost of lectures and publications devoted particularly to the exploitation of a definite scheme of social reform, constitutes a new departure in university policy in regard to research in applied sociology. This scheme "to organise the children and the adolescents in schools and continuation schools, so as to make them form the trunk of a great tree of co-operative production and exchange, whose branches will extend in all directions and carry health into every part of our social system," is not new. Among its earliest supporters were the late Lord Roberts and Sir Horace Plunkett. Of late "economists and educationists in almost every part of the world," says the Vice-Chancellor of Calcutta University, have been canvassed, with the result that there has been a steadily increasing volume of opinion in favour of the scheme, and steps are being taken towards operating a large-scale trial application of it in schools in Bengal by means of self-supporting school market-gardens and school workshops. The experiment cannot fail to arouse keen interest, not only in India but wherever attempts are being made to extend and improve education without increasing its cost.

## Calendar of Industrial Pioneers.

**August 27, 1898. John Hopkinson died.**—Distinguished as an engineer and a mathematical physicist, Hopkinson was a graduate of Trinity College, Cambridge, and in 1871 was senior wrangler and Smith's prizeman. For some years he was scientific adviser to Messrs. Chance, of Birmingham, and made improvements in lighthouse apparatus. As a consulting engineer in London he took up the study of electrical problems; in 1882 patented the three-wire system, and four years later, with his brother Edward, published an important memoir on the principles of the design of dynamos. In 1890 he became professor of electrical engineering at King's College, London, and on two occasions served as president of the Institution of Electrical Engineers. His death was the result of an Alpine accident.

**August 27, 1914. William Thomas Lewis, Lord Merthyr of Senghennydd, died.**—Coal owner, iron master, steel maker, engineer, and a captain of industry, Lewis began life as an apprentice in a South Wales engineering works. In 1860 he became mining engineer to the estates of the Marquis of Bute, and twenty years later was made sole manager. He was a pioneer in the construction of steel works.

**August 31, 1751. Christopher Polhem died.**—A famous mining engineer of Sweden, Polhem was born in 1661, in 1693 became engineer of the mines at Fallem, and in 1716 was raised to the nobility and was made a member of the council of mines. He travelled extensively, carried out important engineering works, and was one of the original members of the Academy of Sciences of Stockholm.

**August 31, 1865. John George Appold died.**—After amassing a considerable fortune as a fur skin dyer, Appold turned his attention to mechanical pursuits and at the Great Exhibition of 1851 attracted attention by his centrifugal pump. Among his other inventions was the brake used in connexion with the laying of the first Atlantic cable.

**September 2, 1834. Thomas Telford died.**—The son of a shepherd of Eskdale, Dumfries, Telford was born on August 9, 1757. Apprenticed to a mason, he afterwards worked in Edinburgh, London, and Portsmouth, became surveyor of public works in Shropshire, engineer of the Ellesmere Canal, and in Scotland built the Caledonian Canal and opened up the country by the construction of 920 miles of roads and of 120 new bridges. Many other bridges, canals, and harbour schemes were due to him, and among these were the Gotha Canal between the Baltic and North Sea and the famous suspension bridge over the Menai Straits. An acknowledged leader in the world of civil engineering, in 1818 he became the first president of the Institution of Civil Engineers and held that position till his death. He died at 24 Abingdon Street, Westminster, and was buried in the nave of Westminster Abbey. His statue stands in the Chapel of St. Andrew.

**September 2, 1883. Cromwell Fleetwood Varley died.**—One of the pioneers of the Atlantic Telegraph Cable, Varley as a boy entered the service of the Electric and International Telegraph Company and of this firm became engineer-in-chief. After the failure of the first Atlantic cable he constructed an experimental line for studying the phenomena of signalling, and during 1864-5 tested the whole of the new cable for the Atlantic Telegraph Company. Retiring from active work in 1868, he continued his investigations and in 1870 transmitted musical sounds over an ordinary telegraph wire. E. C. S.

## Societies and Academies.

## PARIS.

**Academy of Sciences, July 24.**—M. Haller in the chair.—Charles Moreau: The third international conference of pure and applied chemistry. This conference was held at Lyons from June 27 to July 1, and was attended by representatives from 24 nations. The next meeting will be held at Cambridge in June 1923.—Maurice Leblanc: The electrification of railways by means of high frequency alternating currents.—V. Grignard and A. C. Purdy:  $\alpha$ - $\beta$ -dichloroethyl ether. Three of the four possible dichloroethers are known. The fourth,  $\text{CH}_3\text{.CHCl.O.CH}_2\text{.CH}_2\text{Cl}$ , has now been prepared by the action of dry hydrochloric acid upon a mixture of paraldehyde and ethylene monochlorohydrin.—M. Abramesco: The series of polynomials with two complex variables.—Farid Boulad Bey: The geometrical examination of the internal forces and displacements round a point in an elastic body.—Paul Dienes: The displacement of tensors.—Paul Sacerdote and Pierre Lambert: A new method for detecting the presence of a submarine. The plan proposed is suitable for a narrow entrance to a port and is based on the difference between the electric conductivity of the submarine and of sea water.—G. Athanasiu: An actinometer with electrodes of mercury covered with a thin layer of mercurous chloride, bromide, fluoride, or sulphide. A cell is constructed of H form, with mercury electrodes covered with a thin film of haloid salt. Exposure of one electrode to light causes an immediate increase in the E.M.F. of the cell.—St. Procopiu: The variations in the arc spectrum of mercury with the conditions of emission. In a vacuum, working at 14 to 15 volts, with low vapour pressure, there are more lines visible in the ultra-violet (up to 2191) than when working with 65 volts and 3.5 amperes. Other modifications are noted if the arc is working in air or in coal gas, the lines forming the triplets in the two secondary series being specially affected.—Mlle. Irène Curie: The determination of the velocity of  $\alpha$  rays of polonium. The method of deviation in a magnetic field was employed; and this gave  $1.593 \times 10^9$  cm. per second for the velocity of the  $\alpha$  rays of polonium, with a precision of about 0.3 per cent. Geiger, by a different method, obtained a result within 0.4 per cent. of the above.—P. Lebeau and M. Picon: The reactions furnished by sodammonium with hydrocarbons. Paraffins and ethylene derivatives are unacted upon by sodammonium: allylene gives 66 per cent. of the sodium derivative and 33 per cent. of propylene, and other hydrocarbons of the acetylene series behave similarly. Benzene and its derivatives are unacted upon, as are also the terpenes. Naphthalene, acenaphthene, and phenathrene give tetrahydrides.—Octave Mengel: The fall of dust called a "rain of blood." Remarks on the coloured snow which fell in Briangon on March 12, 1922. The meteorological data suggest that this dust came from the Sahara.—Emile F. Terroine and René Wurmser: The utilisation of ternary substances in the growth of *Aspergillus niger*. This mould would appear to utilise indifferently any sugar in its growth, and shows no qualitative preference. The sugars used were glucose, levulose, saccharose, maltose, arabinose, and xylose. The concentration of the nitrogenous food (ammonium sulphate) was also without effect on the growth, but the nature of the source of nitrogen had a marked influence.—L. Blaringhem: The heredity of the physiological characters in the hybrids of barley (second generation).—Paul Becquerel: The theory of the meriphyle in the phenomena of vascular ontogeny.

—A. Pézard: The idea of the "seuil différentiel" and progressive masculinisation of certain female birds. The experimental results relating to the action of the ovary on the plumage of birds can explain, on the hormone theory alone, some anomalies apparently in disagreement with recent theories of endocrinology.—Paul Wintrebret: The mode of building of the vomer in the course of metamorphosis in the Salamandridæ.—Paul Carnot and Marc Tiffeneau: A new hypnotic in the barbituric series: butyl-ethyl-malonylurea. The hypnotic properties of the dialkyl-malonylureas were studied by E. Fischer from dimethyl to the di-isomyl derivative; but the unsymmetrically substituted malonylureas were not examined. This has been taken up by the authors, who find in ethyl-butyl-malonylurea a useful new hypnotic. It has three times the hypnotic power of veronal and has given satisfactory results in clinical practice.

July 31.—M. Guignard in the chair.—The president announced the death of M. Louis Favé.—Emile Picard: The meeting of the International Research Council held at Brussels in July 1922. The address given by M. Picard at the opening of the meeting.—L. Maquenne and E. Demoussy: The influence of calcium on the utilisation of the reserves during the germination of seeds. It has been shown that the influence of calcium on the germination of seeds is specific, and other electrolytes do not produce the same effect. Calcium salts are almost without influence on the diastatic conversion of the insoluble reserves into soluble products; it is possible, but not yet proved, that the ferments responsible for the reconversion of the soluble products into plant tissue may be stimulated by the presence of lime.—R. Chodat and E. Rouge: The intracellular localisation of an oxydase and localisation in general.—Jules Baillaud: Some data on the constitution of the galactic cluster deduced from the study of the zone of the Paris photographic catalogue.—Jean G. Popesco: The relation between photo-electric phenomena and the surface tension of mercury. The surface tension of an electrically charged drop of mercury was measured by a photographic method before and after exposure to ultra-violet light. The results of the experiments show that there is a relation between the photo-electric phenomenon and the surface tension.—E. M. Lémery: The structure of the universe and general relativity.—R. de Malleman: Molecular double refraction and optical activity.—M. Yovanovitch and Mlle. Chamie: The preparation of a standard radium salt. A solution of barium chloride containing radium is precipitated by ammonium carbonate in a special apparatus due to M. Jolibois. The radiferous barium carbonate produced was fairly satisfactory as a standard, different preparations agreeing in their radioactive properties within 0.5 per cent.—Er. Toporescu: The preparation of sodium bicarbonate.—Mlle. G. Marchal: The dissociation of beryllium sulphate. The dissociation pressures are given for seventeen temperatures ranging from 590° C. to 830° C.—Maurice François and Louis Gaston Blanc: A method of preparing the iodobismuthates of the alkaloids in the crystalline state.—H. Gault and T. Salomon: The alkyl-methyl-pyridazinone carboxylic esters.—G. Vavon and A. Husson: Catalysis by platinum black. Platinum black may have its hydrogenating power reduced by the gradual addition of catalyst "poison," such as carbon bisulphide. Thus the activity of a certain specimen of platinum black, after treatment with 0.4 mgr. of carbon bisulphide, lost the power of reducing acetophenone, but retained its catalytic power as regards the reduction of cyclohexene.—Kenneth C. Bailey: The direct synthesis of

urea starting with carbon dioxide and ammonia. Applying the device of the hot and cold tube, carbon dioxide in presence of ammonia in excess and with thoria as catalyst, gave a 10 per cent. conversion into urea.—M. Gignoux and P. Fallot: The marine Pliocene on the Mediterranean coasts of Spain.—A. Guilliermond: Remarks on the formation of chloroplasts in the bud of *Eloidea canadensis*.—G. André: The filtration of plant juices. Comparative analyses of juice expressed from the potato, after clarification by the centrifuge, filtration through porous porcelain filter, and filtration through collodion. In the last case, the proportions of nitrogen and phosphorus present are reduced.—Gabriel Bertrand and B. Benzon: The importance of zinc in the food of animals. Experiments on mice.—H. Vallée and H. Carré: The degree of infection of aphthous fever.—Georges Bourguignon: Double choroaxy and a double motor point in certain human muscles.

## SYDNEY.

Linnean Society of New South Wales, June 28.—Mr. G. A. Waterhouse, president, in the chair.—W. F. Blakely: The Lorantheaceae of Australia, Part ii. A revised classification of the Lorantheaceae, based on that of Engler, is put forward. The most notable changes in the nomenclature affect the genus *Atkinsonia* which is displaced by *Gaiadendron*, while the species under *Loranthus*, with versatile anthers, are transferred to *Phrygilanthus*.—Dr. R. J. Tillyard: Some New Permian Insects from Belmont, N.S.W., in the collection of Mr. John Mitchell. Nearly half the insect wings discovered at Belmont belong to the family Permochoristidae. In association with these are two other Mecopteroid types, viz., *Belmontia* and a new type, described in this paper, which stands in the same relation to the Order Diptera that *Belmontia* does to the Trichoptera and Lepidoptera. In addition the first discovery of a true Lacewing (Neuroptera, Planipennia) of Palaeozoic times is recorded. The remainder of the fauna consists of Homoptera, both Auchenorrhyncha and Sternorrhyncha, a new genus of the latter being described.—J. Mitchell: A new Gasteropod (fam. Euomphalidae) from the Lower Marine Series of New South Wales. Description of a new species of *Platyschisma* from Allandale, where it occurs associated with *P. oculus*, *Eurydesma cordatum*, and *Aviculopecten mitchelli*.—Vera Irwin-Smith: Notes on Nematodes of the genus *Physaloptera*. Part iii. The Physaloptera of Australian Lizards. This paper deals with specimens of *Physaloptera* contained in three collections. They were found to consist of two forms, one of which has been identified as *P. antarctica* Linstow var. *typica*. The other has been treated as a new variety of the same species. Linstow's brief and inadequate diagnosis of the species has been supplemented by a detailed description. The rest of the paper is devoted to a special study of the female reproductive organs, in which it is pointed out that the practice of helminthologists of basing specific distinctions, in this group, upon the dimensions and arrangement of these parts is not reliable, since very considerable variations have been found within the one species.—J. McLuckie: Studies in Symbiosis. i. The Mycorrhiza of *Dipodium punctatum* R.Br.

Royal Society of New South Wales, July 5.—Mr. C. A. Sussmilch, president, in the chair.—A. R. Penfold: Observations respecting some essential oils

from *Leptospermum Liversidgei*. The variation in the essential oils obtained from a well-known Tea Tree (*Leptospermum Liversidgei*) is tabulated as follows:—

No. 1 No. 2 No. 3 No. 4 No. 5 No. 6	Yield.	Specific Gravity 15° C.	Optical Rotation.	Refractive Index.	Solubility in 70 per cent. Alcohol.	Citral.	Citronellal.
	Per cent.					Per cent.	Per cent.
No. 1	0.8	0.8960	+ 6.2°	1.4854	1 in 1.5 vols.	75	type "b"
No. 2	0.5	0.8960	+ 6.2°	1.4822	..	70	type "c"
No. 3	0.25	0.8885	+ 12.10°	1.4822	insol. 10 vols.	46	type "a"
No. 4	0.33	0.8905	+ 12.75°	1.4820	ditto.	46	type "a"
No. 5	0.55	0.8826	+ 11.2°	1.4603	1 in 1.5 vols.	82	type "c"
No. 6	0.6	0.8910	+ 7.25°	1.4832	ditto.	70	type "b"

The author is inclined to the opinion that there are probably three forms of this shrub, and points out that the types "b" and "c" are of great economic importance. The type "a" (the original one) is of very little commercial value, hence the importance of the other types, particularly as botanical diagnosis has so far failed to distinguish them.—A. R. Penfold and F. R. Morrison: Preliminary note on a new Stearoptene (probably a phenol ether) occurring in some essential oils of the Myrtaceae. The authors announced the isolation of a beautifully crystalline solid of a yellow colour from the essential oils of *Baekea crenulata* and *Darwinia grandiflora*. It has a melting-point of 103-104° C., molecular formula C<sub>13</sub>H<sub>18</sub>O<sub>4</sub>, and contains two methoxy groups. It is apparently a phenol ether. It has, so far, only been obtained in small quantity, amounting to 6 per cent. in the former, and 2 per cent. in the latter oils, but it is anticipated that other essential oils at present being investigated will yield it in greater amount.—J. K. Taylor: A chemical and bacteriological study of a typical wheat soil of New South Wales. Monthly determinations of soil moisture, bacterial numbers, nitrates, and nitrifying power were made in soil from various plots at Wagga Experiment Farm. The bacterial numbers, nitrates and nitrifying power were greater in summer than in winter in spite of the partial drying out of the soil. The general order of merit of the plots for bacterial activity and accumulation of nitrates was cultivated fallow, cropped land, uncultivated fallow, and grass land. The bacterial numbers are comparable with those from soils from similar climatic regions but the nitrifying power is not particularly good and fluctuated curiously from month to month.

## Official Publications Received.

Annals of the Astrophysical Observatory of the Smithsonian Institution. Vol. 4. (Publication No. 2661.) Pp. xii+390. (Washington: Smithsonian Institution.)

The British Mycological Society. Transactions, 1920. Vol. 7, Part 4. Edited by Carleton Rea and J. Ramsbottom. Pp. 221-324. (London: Cambridge University Press.) 12s. 6d.

Memoirs of the Asiatic Society of Bengal. Vol. 6: Zoological Results of a Tour in the Far East. Edited by Dr. N. Annandale. Part 7. Pp. 397-433+plates 15-17. 2 rupees; 3s. Part 8. Pp. 435-459+plates 18-21. 2 rupees; 3s. Vol. 7, No. 4: Introduction to the Study of the Fauna of an Island in the Chilika Lake. By Dr. N. Annandale. Pp. 257-319+plates 7-11. 3 rupees; 4s. 6d. (Calcutta: Asiatic Society of Bengal.)

The Newcomen Society for the Study of the History of Engineering and Technology. Transactions, Vol. 1, 1920-1921. Pp. 88-118 plates. (London: Newcomen Society.) 20s.

University of Colorado Bulletin. Vol. 22, No. 3; General series, No. 180: Catalogue, 1921-1922. Pp. 426. (Boulder, Colo.: University of Colorado.)

Experimental Researches and Reports published by the Department of Glass Technology, The University, Sheffield. Vol. 4, 1921. Pp. ii+118. (Sheffield: The University.)

# NATURE

A WEEKLY ILLUSTRATED JOURNAL OF SCIENCE.

*"To the solid ground  
Of Nature trusts the mind which builds for aye."*—WORDSWORTH.

No. 2757, VOL. 110]

SATURDAY, SEPTEMBER 2, 1922

[PRICE ONE SHILLING

Registered as a Newspaper at the General Post Office.]

[All Rights Reserved.]

## BALANCES & WEIGHTS



## SPECTROMETERS

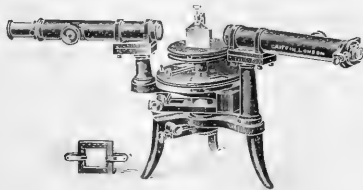

Particulars and Prices on application to—

**JOHN J. GRIFFIN & SONS, LTD.**  
Kemble Street, Kingsway,  
London, W.C.2.

DO YOU KNOW  
THAT  
**VITREOSIL LABORATORY WARE**

is  
Incomparably Superior  
to any other similar Material?

It is  
Constant in Weight, Reliable,  
and Reasonable in Price.

Write for Pocket Edition of  
Price List.

**HEAT  
PROOF**



**ACID  
PROOF**

SOLE MANUFACTURERS  
**THE THERMAL SYNDICATE, LTD.,**  
VITREOSIL WORKS—WALLSEND-ON-TYNE.  
LONDON DEPOT—28 VICTORIA ST., S.W.1.  
ALSO AT PARIS AND NEW YORK.

## HIGH RANGE THERMOMETERS

Of Guaranteed Accuracy.

**NATIONAL PHYSICAL LABORATORY**

certificate of N. & Z. Thermometer No. D 10520.

Reading.	Correction.
212 F.	0 F.
300	0
400	0
500	+1
600	+1
700	0
805	0

Above is a copy of certificate of a Thermometer  
recently verified.

**NEGRETTI & ZAMBRA**  
38, HOLBORN VIADUCT, E.C.1.  
LONDON.

# UNIVERSITY OF BIRMINGHAM.

## FACULTIES.

**Science:** Subjects—Mathematics, Physics, Chemistry, Zoology, Botany, Geology, Engineering (Mechanical, Civil, Electrical), Metallurgy, Mining (Coal, Metal, Petroleum), Bio-Chemistry of Fermentation.

**Arts:** Subjects—Latin, Greek, English, French, German, Italian, Spanish, Russian, Philosophy, History, Music.

**Medicine:** All subjects leading to Degrees and Diplomas in Medicine and Dentistry.

**Commerce:** Subjects leading to Degrees in Commerce.

Department of Training for Teachers.

Department of Social Study.

Department of Malting and Brewing.

## THE SESSION 1922-23 COMMENCES ON OCTOBER 2, 1922.

### ALL COURSES AND DEGREES ARE OPEN TO BOTH MEN AND WOMEN STUDENTS.

In the Medical School Courses of Instruction are arranged to meet the requirements of other Universities and Licensing Bodies.

Graduates, or persons who have passed Degree Examinations of other Universities, may, after one year's study or research, take a Master's Degree.

**Separate Syllabuses** with full information as to Lecture and Laboratory Courses, Fees, Regulations for Degrees, Diplomas, &c., Exhibitions, and Scholarships, are published as follows:

1. Faculty of Science.
2. Faculty of Arts.
3. Faculty of Medicine.
4. Faculty of Commerce.
5. Department of Social Study.
6. Department of Biology and Chemistry of Fermentation.
7. Exhibitions, Scholarships, &c.,

and will be sent on application to the REGISTRAR.

## BATTERSEA POLYTECHNIC, LONDON, S.W.11.

*Principal*—ROBERT H. PICKARD, D.Sc., F.R.S.

*Head of Chemical Department*—J. KENYON, D.Sc., F.I.C.

Day and Evening Courses for London B.Sc. (Pass and Honours) in Chemistry, Physics and Mathematics.  
Three or Four Year Day Course in Pure and Applied Chemistry, including Chemical Engineering.

### SPECIAL EVENING COURSES (LECTURES AND LABORATORY) IN CHEMISTRY.

#### CHEMICAL ENGINEERING.

Lect. 1st yr. Fri. 7.15 to 8.15,  
2nd yr. Fri. 8.30 to 9.30.

Lab. H. Griffiths, B.Sc., A.R.C.S.,  
Wed. 7 to 9.30.

#### BACTERIOLOGY.

Tues. Wed. and Fri. 7 to 9.30.

J. H. Johnston, B.Sc., F.I.C.

#### ANALYSIS OF FOODS.

Wed. 7 to 9.30. Lectures and

Practical.

J. H. Johnston, B.Sc., F.I.C.

#### TESTING OF DISINFECTANTS.

Tues. 7 to 9.30.

J. H. Johnston, B.Sc., F.I.C.

#### FLOUR MILLING.

(1) Flour Milling, Thurs. 7 to 8.30.

C. E. Smith.

(2) Elem. Science as applied to

Milling, Thurs. 6 to 7.

A. Houssa, B.Sc., A.I.C.

(3) Machine Drawing, Fri. 7.30

to 9.30.

*2nd year course.*

(1) Flour Milling, Wed. 7 to 8.30.

C. E. Smith.

(2) Elem. Science as applied to

Milling, Wed. 6 to 7.

A. Houssa, B.Sc., A.I.C.

Day and Evening Courses commence Monday, September 25.

Enrolment of students commences Tuesday, September 26.

Abridged Calendar of all classes gratis on application to the PRINCIPAL.

(3) Machine Drawing, Fri. 7.30

to 9.30.

#### OILS, FATS AND WAXES.

Tues. 7.15 to 9.45, September to

Christmas, 1922.

W. H. Simmons, B.Sc., F.I.C.

#### MINERAL OILS AND WAXES.

Fri. 7.15 to 9.45, September to

Christmas, 1922.

W. H. Simmons, B.Sc., F.I.C.

#### LUBRICATING OILS AND GREASES.

Fri. 7.15 to 9.45, January to

Easter, 1923.

W. H. Simmons, B.Sc., F.I.C.

#### TOILET SOAPS MANUFACTURE.

Tues. 7.15 to 9.45, January to

Easter, 1923.

W. H. Simmons, B.Sc., F.I.C.

#### PAPER MAKING (ENGINEERING).

Mon. 7.15 to 8.45 (1st term).

K. Marx, B.Sc.

#### PAPER TESTING.

1st year. Wed. 7.15 to 9.45.

2nd year. Fri. 7.15 to 9.45.

D. R. Davey, B.Sc.

## CHELSEA POLYTECHNIC,

CHELSEA, S.W.3.

Session begins September 25, 1922.

Day and Evening Courses in Science under Recognised Teachers of London University.

### I. INDUSTRIAL CHEMISTRY DEPARTMENT.

Technical Courses in Analytical and Manufacturing Chemistry, Pharmacy, Food and Drugs, A.I.C. Courses, Metallurgy, Assaying, Foundry Work, Research.

### II. INDUSTRIAL PHYSICS DEPARTMENT.

Practical work in General Physics, Applications to Industries, Metrology, Calorimetry, Illumination, Acoustics, Electrical Measurement, Research.

### III. BIOLOGICAL AND GEOLOGICAL DEPARTMENT.

Courses for B.Sc., etc., in Botany, Geology, Mineralogy, Zoology, Special Courses in Bio-chemistry, Bio-physics, Bacteriology, Physiology, Hygiene, Entomology, Plant Pathology. Course for Tropical Planters, Research.

SIDNEY SKINNER, M.A.,

Principal.

Telephone: Kensington 899.

## EAST LONDON COLLEGE (UNIVERSITY OF LONDON),

MILE END ROAD, E.1.

PASS AND HONOURS COURSES IN THE

FACULTIES OF ARTS,

SCIENCE AND ENGINEERING.

FIRST YEAR MEDICAL COURSE.

POST GRADUATE AND RESEARCH WORK.

Fees—Twenty Guineas a year.

EVENING COURSES, M.A. FRENCH, M.A. & M.Sc.

MATHEMATICS.

RESEARCH WORK IN EXPERIMENTAL SUBJECTS.

Fees from Two Guineas a session.

SESSION COMMENCES OCTOBER 2.

## BIRKBECK COLLEGE.

(UNIVERSITY OF LONDON.)

*Principal*—GEORGE SENTER, D.Sc., Ph.D., F.I.C.

EVENING COURSES for the Degrees of the University of London in the Faculty of Science and for the Geography Diploma.

Facilities are also provided during both day and evening for Post-Graduate and Research Work.

Calendar, 1s.; by post, 1s. 5d. Prospectus free.

For full particulars, apply to the SECRETARY, Birkbeck College, Fetter Lane, E.C.4.

## BATTERSEA POLYTECHNIC.

*Principal*—\* ROBERT H. PICKARD, D.Sc., F.R.S.

University Courses, day and evening, under Recognised Teachers of the University of London are provided in Science, Engineering and Music.

CHEMISTRY.—\* J. KENYON, D.Sc., F.I.C.; \* J. L. WHITE, D.Sc.

PHYSICS.—\* S. MARSH, B.Sc., Ph.D.; \* A. E. EVANS, B.Sc.; \* J. F.

PHILLIPS, B.A., B.Sc.

MATHEMATICS.—\* F. M. SAKELID, M.Sc., B.A.; \* F. W. HARVEY,

B.Sc., M.A.; \* W. G. BICKLEY, M.Sc.

MECHANICAL AND CIVIL ENGINEERING.—\* W. E. M.

CORROCK, M.Sc., B.Eng.; \* J. B. SHAW, A.R.C.S., Wh.Eng.; \* H. M.

EDMONDS, B.Sc.; \* V. C. DAVIES, B.Sc., A.M.I.Mech.E.

ELECTRICAL ENGINEERING.—\* A. T. DOVER, M.I.E.E.,

A. Am.I.E.E.; \* H. C. MANS, A.M.I.E.E.

MUSIC.—\* H. D. WETTON, Mus. Doc., F.R.C.O.

\* Denotes recognised teacher of University of London.

There are also:

Day Technical College in Engineering and Science. Day Training

College of Domestic Science. Day Department of Hygiene and

Physiology. Day School of Art and Crafts.

Evening Courses in Engineering, Chemistry, Physics, Mathematics,

Bacteriology, Chemical Engineering, Hygiene and Physiology, Art,

Matriculation Subjects, Domestic Economy, Music, Physical Training,

Hostels for Women Students. Large playing fields at Merton.



SATURDAY, SEPTEMBER 2, 1922

## CONTENTS.

	PAGE
Children and Museums . . . . .	301
Ninety Years of British Science. . . . .	302
A Standard Treatise on Crystallography . . . . .	303
New Editions of Chemical Works . . . . .	305
Phosphatic Fertilisers. By H. J. P. . . . .	306
Our Bookshelf . . . . .	307
Letters to the Editor:—	
Spectrum Lines of Neutral Helium.—Prof. W. M. Hicks, F.R.S. . . . .	309
Micro Methods in the Practical Teaching of Chemistry.—Prof. Egerton C. Grey . . . . .	309
An Atomic Model with Stationary Electrons.—Dr. H. S. Allen . . . . .	310
The Variable Depth of Earthquake Foci.—Dr. Dorothy Wrinch and Dr. Harold Jeffreys . . . . .	310
An Electrical Analogue of the Vocal Organs.—John Q. Stewart . . . . .	311
Interspecific Sterility.—Dr. J. W. H. Harrison . . . . .	312
The Mass Spectrum of Iron.—Dr. F. W. Aston, F.R.S. . . . .	312
Density of Absorbed Films.—R. M. Deeley . . . . .	313
The Pigeon Tick.—L. H. Matthews and A. D. Hobson . . . . .	313
An Ancient Wasp.—Prof. T. D. A. Cockerell . . . . .	313
Black Coral.—Dr. M. Nierenstein . . . . .	313
The Zoological Society. ( <i>Illustrated.</i> ) By E. G. Boulenger . . . . .	314
The Resonance Theory of Audition. ( <i>With diagram.</i> ) By Prof. E. H. Barton, F.R.S. . . . .	316
The Lesser Whitethroat's Fanfare. By Prof. W. Garstang . . . . .	319
Obituary:—	
W. H. Hudson . . . . .	319
Current Topics and Events . . . . .	320
Research Items . . . . .	322
The Weights and Measures of India. By C. A. Silberrad . . . . .	325
School Instruction in Botany . . . . .	320
University and Educational Intelligence . . . . .	330
Calendar of Industrial Pioneers . . . . .	331
Societies and Academies . . . . .	332

*Editorial and Publishing Offices:*

MACMILLAN & CO., LTD.,

ST. MARTIN'S STREET, LONDON, W.C.2.

Advertisements and business letters should be addressed to the Publishers.

Editorial communications to the Editor.

Telegraphic Address: PHUSIS, LONDON.

Telephone Number: GERRARD 8830.

NO. 2757, VOL. 110]

## Children and Museums.

THE direct educational work accomplished by museums in the United States is a perpetual source of shame to us in this country. We are well aware that much is being done in some of our own museums, often at the self-sacrifice of their officials; but have we anything to compare with what is described in a recent number of *Natural History* (March-April 1922)—the journal of the American Museum of Natural History? Consider lantern-slides, for example. Our own Natural History Museum has recently started one or two loan collections, comprising in all some few dozen slides. Those of the American Museum number many thousands. They are stored in a room accessible to teachers, who can thus select precisely what they want for their class-room lectures. Last year more than two hundred thousand slides were circulated. It is not long since a fair collection of slides made by an assistant in our own museum was handed over to another institution because there were no facilities for keeping it in the museum itself. Needless to say, the American Museum has a lecture theatre. It has 869 nature-study collections to be lent to any public school in greater New York. There are two motor cars and a motor cycle to deliver slides and collections. Each messenger visits from twenty to forty schools a day. The American Museum is about to erect a special School Service building of five storeys where from three to five thousand children daily may be taken care of properly. The blind are also provided for.

Of course, all this cannot be done by the ordinary officers of the museum, and that is a fact which must be recognised in this country. The American Museum has its own Department of Education, with Mr. George H. Sherwood at the head. In the same way the Brooklyn Botanical Garden has its Curator of Elementary Education, who contributes to the same issue of *Natural History* an interesting article on "Gardening and the City Child." But the work which starts in the museums and public gardens of New York and Brooklyn is taken up by other outside bodies, as the School Nature League of New York City, the president of which, Mrs. John I. Northrop, here tells us how in one of the elementary schools in the middle of the slums a wonderful nature-room has been installed. It is visited by from eight hundred to one thousand children every week. Here is a place for all those miscellaneous curiosities so frequently rejected by the staid museums. They can be placed in the hands of the children and many a fascinating lesson drawn from them. The love of nature thus begun is carried out into the open by means of summer camps,

and so becomes linked up with the Boy Scout camps with their travelling museums.

Well, why is it that the Americans have got so far ahead of us on these lines? They have no doubt a new field to cultivate, and they do not have to contend against the terrible weight of inertia inevitable to some of our royal and ancient establishments. But to a large extent it is because Americans are not ashamed of having an ideal and of talking about it. They do not mind saying what they are going to do, and they make the utmost of everything that they have done. This is not the Englishman's way, but it is a way that interests the public both rich and poor. It brings money from the former and enthusiasm from the latter. If we want to achieve the same results we must not be above following somewhat similar methods. Here, during the summer holidays, are the children crowding our museums at South Kensington day after day. Cannot something more be done for them, even if we shed a little dignity in the process?

### Ninety Years of British Science.

*The British Association for the Advancement of Science: A Retrospect, 1831-1921.* By O. J. R. Howarth. Pp. vii+318. (London: British Association, Burlington House, 1922.) 7s. 6d.

MR. HOWARTH is to be congratulated on the manner in which he has used his opportunity, while the record he has produced is a most ample justification of the title of the Association—the British Association for the Advancement of Science—British in that its meetings have been held in nearly every part of the Empire, India excepted; and perhaps, as the part India can play in advancing science is more fully recognised, we may in the years to come have a meeting at Delhi, the centre of a civilisation dating back centuries before the Association.

The work is due to a suggestion made by Sir Charles Parsons when president in 1919-20, and owes much to his generous support, while the author has been helped in his task by many friends whose assistance is gratefully acknowledged in the preface. Commencing with the history of the foundation of the Association in 1831, the work deals with its relation to the advancement of science, its organisation and meetings, its aid to research, its connexion with the State, and its work overseas. The author states that his aim has been "to provide a summary review of its activities, with examples," and this he has done with conspicuous success.

Founded in 1831, the Association's life of ninety years has been full of stirring events. Sir David Brewster was its founder; in the *Edinburgh Journal of*

*Science* (vol. 5, 1831) he wrote: "Some months ago it occurred to the editor of this work [himself] that the general interests of science might be greatly promoted by the establishment of a Society of British Cultivators of Science which should meet annually in some central town in England." In writing this Brewster had in mind the work of the *Deutscher Naturforscher Versammlung*, about which an article had appeared in the preceding volume of the journal. The objects of the meeting of this society were, as the author of this article stated, to promote "acquaintance and friendly personal intercourse among men of science; but other great and more important benefits grow out of them." "Might not," he continued, "similar results in our older country be looked for from a similar institution." This statement sums up the work of the Association. Similar results have followed, but to an extent undreamt of by Brewster and his colleagues. The first meeting was held at York. Dalton was there—"old Dalton, atomic Dalton, reading," as Murchison wrote later, "his own memoir, and replying with straightforward pertinacity to every objection in the highly instructive conversations which followed each paper."

Ninety years later the atom has been resolved into its constituent electrons, and Thomson, Rutherford, and Bohr have stated in no uncertain terms the laws which govern the planetary system of the atom, atom no longer when subject to the bombardment of the swift-moving electrons of the cathode rays.

The second meeting of the Association was held at Oxford, and the third at Cambridge. Sedgwick was president, and Mr. Howarth has printed an interesting selection of autographs of members present—Brewster, Airy, Babbage, Faraday, Forbes, Herschel, Buckland, Harcourt, Murchison, Phillips, Peacock, Rigaud, Sedgwick, Whewell, Houston, etc., all great names; the physical sciences predominate. Biology was not, or rather it was represented by a little natural history, with some botany and geology. Of the Oxford meeting Murchison, afterwards general secretary and (1846) president, wrote that "under the presidency of Buckland, the body was licked into shape and divided into six sections."

Started thus under brilliant auspices, the Association has been a potent factor in the advancement of science; in its earlier years, it is true, it met with criticism and ridicule in some quarters—Dickens's "Mudfog Papers" may be mentioned; these it has outlived, and the striking success of the Edinburgh Meeting of 1921 showed that even in the altered conditions of the twentieth century there is still ample work for it to undertake.

Turning now to a brief reference to its numerous



activities, from the commencement these have not been confined to the period of its annual meetings, and its main contributions to the advancement of science have been through the work of its various committees, aided by grants from its funds, and through the reports on the state of some special science drawn up by a member deputed for this work. "We repudiate," wrote Murchison in 1845, "that the chief aim of our existence is to stir up a few embers of scientific warmth in the provinces," and Owen, president in 1858, claimed that the association was realising the dream of Francis Bacon recounted in his "New Atlantis." Whewell in 1862 wrote: "The Association wants money and ought to get it for it spends a great deal;" he might have added, on objects of the utmost importance to the welfare and progress of mankind.

Mr. Howarth has given in an Appendix a complete list of the grants for research.

The following is a summary of these:

Section.	l.	s.	d.
A (Mathematics and Physics) . . . . .	34,977	18	7
B (Chemistry) . . . . .	4,178	17	8
C (Geology) . . . . .	6,956	3	11
D (Zoology) and K (Botany) jointly . . . . .	1,579	1	10
E (Geography) . . . . .	12,093	15	5
F (Economics) . . . . .	3,695	13	4
G (Engineering) . . . . .	1,322	4	3
H (Anthropology) . . . . .	4,164	7	6
I (Physiology) . . . . .	7,226	16	11
J (Botany) . . . . .	3,115	13	7
K (Botany) . . . . .	1,952	15	1
L (Education: founded in 1901) . . . . .	538	18	6
M (Agriculture: founded in 1912) . . . . .		5	0

The total sum expended since 1834 has been about 83,000*l.*, somewhat less than 100*l.* a year it is true, but no inconsiderable sum when it is remembered it has been raised almost entirely from the subscriptions of its members, in the main men and women of science themselves.

The attempt to give details of the researches promoted by these grants would occupy far too much space. An interesting account will be found in Mr. Howarth's pages. Reference may, however, be permitted to a few taken from the list for Section A. Between the years 1862 and 1910 about 1100*l.* was spent in establishing electrical standards, which are now adopted throughout the world and have formed the foundation on which the whole edifice of applied electricity is reared. The observatory at Kew was supported from 1843 to 1872 in great measure by grants of more than 12,000*l.*, and for many years, by the issue of accurate standards and in other ways, promoted in a marked degree meteorological science. Under the subject Heat we find "Remeasurement of dynamical equivalent, 1870-80, 106*l.* os. 6*d.*"; Joule's work was thus supported by the Association. Seismology has been aided to the extent of more than

2500*l.*, while grants to tidal observations have reached about the same sum. Similarly, from the other Sections examples might be given, showing the influence the Association has exerted on progress and the value and wide scope of its work. For ninety years the Association has laboured, a union of voluntary workers for the advancement of science. In the words of Rayleigh, president in 1884, "The work may be hard and the discipline severe, but the interest never fails, and great is the privilege of achievement." Of the achievements of the Association Mr. Howarth's book is a fitting record.

### A Standard Treatise on Crystallography.

*Crystallography and Practical Crystal Measurement.* By Dr. A. E. H. Tutton. Second edition. In 2 vols. Vol. 1: *Form and Structure.* Pp. xvii + 746 + xiv. Vol. 2: *Physical and Chemical.* Pp. viii + 747-1446. (London: Macmillan and Co., Ltd., 1922.) 50*s.* net each.

THE eleven years which have elapsed since the first edition of this work appeared, have witnessed a remarkable and welcome increase in the interest taken in crystals by chemists and physicists. On the chemical side this has been due partly to the efforts made by Pope and Barlow to correlate chemical composition and crystalline form, and partly to the tardy recognition on the part of organic chemists that the crystal form and optical properties of a substance, once accurately determined, form the most valuable means of identifying it that we possess. On the physical side interest has been aroused by the remarkable discovery of Laue and his collaborators that the conception of a crystal as an orderly arrangement of very minute particles arrived at by the experimental study of crystal morphology, and also from purely geometrical considerations, had a solid basis in fact and could be demonstrated by the diffraction of Röntgen rays. In the hands of the Braggs and of others working on similar lines, this discovery has led to a very wonderful increase in our knowledge of crystal structure. It is natural that these advances should be reflected in the work before us, and we find accordingly that Dr. Tutton has found it necessary to employ nearly five hundred additional pages to deal with the wealth of matter the past ten years have provided.

This has necessitated the division of the work into two volumes, each consisting of two sections, and has also led to a certain amount of re-arrangement of the material contained in the first edition. The first section, which occupies nearly one-third of the whole work, deals with crystal measurement by means of

the one-circle, horizontal, reflecting goniometer, and follows closely on the lines of the original edition. A useful account of methods of goniometry at low temperatures has been introduced; and the use of the two- and three-circle goniometers, and the methods based on the gnomonic projection and associated with the name of V. Goldschmidt, receive more adequate treatment than before. The student will, however, miss in this chapter the extraordinarily detailed description of every step in experiment and in computation to which Dr. Tutton has accustomed him in what has gone before; and when he finds that three hundred pages are devoted to the discussion of one-circle goniometry the enthusiast for two-circle methods will scarcely perhaps feel content with part of one chapter. Many readers will wish for fuller information as to the methods of drawing crystals devised by Penfield and by Goldschmidt, and would have welcomed some account of the ideas on "complication" developed by the latter.

The second half of the first volume deals with crystal structure and X-ray analysis and contains much new matter. In particular, attention may be directed to the well-illustrated and concise account of the Sohncke point systems and also to the useful table of the 230 space groups, which will be found helpful as an introduction to a somewhat inaccessible part of the subject. Dr. Tutton's treatment arouses the wish that he had used his powers of clear exposition to elucidate still further these difficult but very important matters. The chapter on the application of X-rays to the determination of crystal structure gives an admirable account of the progress that has been made, while the sketch of Fedorov's views on the correct setting of crystals and on the compilation of a dictionary of crystal forms to facilitate the identification of chemical compounds by their morphology alone, whets our curiosity, and leads us to wish that Dr. Tutton had shown us how to work out the reticular density and the correct setting in a few typical cases.

The third section deals in the main with crystal optics, and begins with an introductory chapter which contains readable accounts of matters so diverse as thermionic valves, radio-activity, atomic numbers, isotopes, theories of atomic structure, the Zeeman effect, Aston's positive ray mass spectrograph, the Michelson echelon, and the Lummer-Gehrcke plate. The succeeding chapters are in the main reprinted from the first edition, but the treatment of the modes of production of monochromatic light is fuller and includes a useful description of the mercury vapour lamp. When explaining the colour effects observed when thin crystalline plates are placed between crossed Nicols, Dr. Tutton says: "The Nicol analyser itself introduces,

when crossed to the polarising Nicol, a change of phase of half a wave-length, like the act of reflection in the case of thin films, and this  $\lambda/2$  requires to be added to the retardation of one ray behind the other brought about in traversing the crystal." Experience has shown that this statement is a source of perplexity to the average student, and it is to be regretted that Dr. Tutton has not followed the more readily intelligible treatment adopted by Groth in the successive editions of his "Physikalische Kristallographie."

The general excellence of the illustrations is so high that the figures explanatory of the use of the mica plate in finding the optical sign of crystals seem scarcely to come up to the standard. A photograph of the phenomenon reproduced as a plate would have been more in keeping with the style of the book. The figures and descriptions of polarimeters for finding the optical rotation of liquids take up valuable space and seem scarcely necessary in a work on crystallography; indeed, the connexion of much of the matter in this section with crystals is somewhat remote, although the reader will perhaps forgive the author its introduction for the sake of its intrinsic interest, a case in point being the account of the use of the barium platinocyanide screen for secret signalling during the war. The last two chapters of this section contain a full description of the various types of microscopes and of the principal methods employed in the microscopic examination of crystals, both when isolated, or when occurring in rock slices.

The concluding portion of the book opens with an excellent discussion of isomorphism, isogonism, polymorphism, and enantiomorphism, which may be especially commended to the notice of chemists, who will find therein much interesting information as to recent work not easily accessible elsewhere. The next chapters are devoted to the thermal and elastic properties of crystals, and in particular to full descriptions of the ingenious and elaborate apparatus devised by Dr. Tutton for measuring them, and to these have been appended somewhat irrelevant accounts of the Interferential Comparator for standards of length, the Michelson Interferometer, and the Etalon of Fabry and Perot. The final chapters of the book are devoted to the consideration of the electric and magnetic properties of crystals, and to a brief but sufficient account of so-called "liquid crystals."

It will be seen, then, that these two volumes are a mine of accurate information on matters belonging to a wide field of knowledge, and testify alike to the learning and industry of the author and to the enterprise of his publishers. The wealth of detail of many of the descriptions, the large number and excellence of the illustrations, and the considerable amount of irrelevant

matter introduced have naturally made the book both bulky and expensive to produce. It is to be feared that the consequent high price will place it out of the reach of the ordinary student, to whom, if we may judge by the long section on one-circle goniometry, it would seem mainly to be addressed. Had Dr. Tutton resisted the temptation to figure and describe every piece of elaborate and expensive apparatus which aroused his interest, and had he omitted all the paragraphs which have nothing to do with crystals, the length and cost of the book might have been very considerably reduced, and its accessibility to the student thereby increased, without in the least diminishing its value as a compendium of all that is worth knowing about crystal measurement as practised to-day.

### New Editions of Chemical Works.

- (1) *A Dictionary of Applied Chemistry*. By Sir Edward Thorpe. Vol. 3. Revised and enlarged edition. Explosives—Kyrofin. Pp. viii + 735. (London: Longmans, Green and Co., 1922.) 3l. net.
- (2) *Metallography*. By Prof. Cecil H. Desch. (Text-Books of Physical Chemistry.) Third edition. Pp. xi + 440. (London: Longmans, Green and Co., 1922.) 16s. net.
- (3) *A Concise History of Chemistry*. By Dr. T. P. Hilditch. Second edition, revised. Pp. xi + 276. (London: Methuen and Co., Ltd., 1922.) 6s.
- (4) *An Introduction to the Principles of Physical Chemistry from the Standpoint of Modern Atomistics and Thermodynamics*. By Prof. E. W. Washburn. Second edition, revised, enlarged, and reset. Pp. xxviii + 518. (New York and London: McGraw-Hill Book Co., Inc., 1921.) 20s. net.
- (5) *Die Wasserstoffionen-Konzentration: ihre Bedeutung für die Biologie und die Methoden ihrer Messung*. Von Prof. Dr. Leonor Michaelis. (Monographien aus dem Gesamtgebiet der Physiologie der Pflanzen und der Tiere, Band I.) Zweite, völlig umgearbeitete Auflage. Teil 1: Die theoretischen Grundlagen. Pp. xi + 262. (Berlin: J. Springer, 1922.) 69 marks; New Edition, 8s. 6d.

THE reviewing of new editions is a difficult and somewhat thankless task, if only on account of the detailed comparison which is needed in order to discover the novel features which alone call for comment or criticism. The four works in English of which new editions are here noted are all well known, and it would be superfluous to refer to their obvious merits, except in so far as they have been enhanced by the revision which they have undergone.

(1) The first two volumes of the new edition of the "Dictionary of Applied Chemistry" have received

adequate notice in these columns. The third volume covers the letters F to K, but begins with an article on "Explosives," which has obviously been carried over from the preceding volume on account of its length and importance. In revising this article Mr. Perry has expanded it to nearly 100 pages by including notes on a large number of new explosives which have come into use during the last few years. The article thus continues to fulfil in its own field the main purpose for which a dictionary exists, namely, to provide some information in reference to every topic which may give rise to inquiry. The main lines of development of the manufacture on a very large scale of a few principal explosives during the war are, however, also adequately dealt with, and useful information is given on points such as the preparation, purification, and properties of T.N.T., and its use in the manufacture of amatol. The portion of the dictionary which is included in the present volume has been expanded by nearly one-quarter from 602 to 735 pages, and a somewhat careful comparison of the old and new editions has shown that, almost without exception, each of the important articles has contributed to this expansion. Fresh features of the new edition include an article on the interferometer by H. H. Robinson, and an article on hardened or hydrogenated oils by C. A. Mitchell, while gas warfare forms the subject of a short unsigned article. A completely new article on glass, by Prof. W. E. S. Turner of Sheffield, has replaced the article on the same subject which appeared in the old edition; the illustrations given in the new article of the automatic machines used for the manufacture of bottles are remarkable as suggesting something even more complex than the engine-room of a submarine. Throughout the volume there is evidence of adequate revision, which fully justifies the issue of the new edition.

(2) The third edition of Prof. C. H. Desch's "Metallography" retains all the valuable features on which the reputation of the book has been built. Substantial additions have been made in the chapter on the physical properties of alloys, where important developments which had taken place since 1913, especially in the study of magnetic and electrical properties, are described. Additions have also been made to the chapter on corrosion, in which the recent work by Dr. J. N. Friend in the *Journal of the Chemical Society*, is now incorporated, together with other work which has appeared in the *Journal of the Institute of Metals* and the *Transactions of the Faraday Society*, where a general discussion on this subject is reported. The chapter on the metallography of iron and steel has also been revised, one important new feature being an equilibrium diagram for iron and nickel, in which the changes that take place in the solid metal as it passes

from the non-magnetic into the magnetic condition are represented by lines, which show the formation of a definite series of solid solutions, instead of by blurred areas. The appendix, in which the various binary, ternary, and quaternary systems which have been studied are classified and summarised, has been revised to include publications received down to the time of going to press. The new edition incorporates the results of nine years of work in metallography, and it can be heartily commended for its up-to-date presentation of this important subject.

(3) The first edition of Dr. Hilditch's "Concise History of Chemistry" was reviewed in NATURE of October 19, 1911, p. 510. The new edition has been expanded from 263 to 276 pages, and, in view of the number of additional topics that have come into prominence during the past ten years, it is clear that the conciseness of the old edition has been at least fully maintained in the new. It will thus be found that the nucleus atom, X-ray analysis of crystals, Moseley's atomic numbers, the octet theory of Langmuir and the discovery of isotopes, are all described in the course of three pages in the chapter on the "Ultimate Constitution of Matter," although another page is given later on to some of these subjects. Gas warfare is described in a paragraph of eleven lines, and "anti-gas" is summed up in a paragraph of four lines. In a few details only the revision is perhaps incomplete, e.g. the list of the metals of the rare earths is still that of 1909, with holmium omitted, and the atomic weights (which are of the same date) might well have been supplemented by giving also the atomic numbers; moreover, the new matter is by no means fully represented in the subject index, although the author-index appears to have been revised. The value of the book as an index of chemical discoveries is preserved in the new edition, although it would obviously be useless to look for detailed descriptions in so compact a volume.

(4) Prof. Washburn's "Principles of Physical Chemistry" was reviewed in these columns on June 1, 1916, p. 277, and has established a wide reputation in this country as well as in the country of its origin. As the first edition appeared but seven years ago, only those subjects which have developed since the war have called for further elaboration. These include, however, the work of Aston on isotopes and all the recent work on atomic and molecular structure. It is, indeed, remarkable evidence of the rapid progress which has been made in this field that, while the first edition stops with an account of the qualitative aspects of the periodic classification, and of the models which Soddy and Harkins put forward in order to explain the sequence of properties, these two figures have disappeared in the second edition in favour of a large chart

illustrating the Lewis-Langmuir theory; and this chart in turn is probably already obsolete in view of the suggestions put forward by Bohr for making use of the quantum-orbits of the electrons as a basis for the periodic classification of the elements. The work on the X-ray analysis of crystal-structure, which was briefly mentioned in the first edition, claims eight pages in the second edition. Anisotropic liquids are, however, inadequately (and perhaps incorrectly) dealt with, especially in view of recent French work on this subject.

(5) Dr. Michaelis's book on "Hydrogen Ion Concentration" was first issued in 1914. The present volume is a new edition of the first and theoretical part of the book, and covers two main topics, namely, the chemical equilibrium of ions and ions as sources of differences of electrical potential. The subject has attracted even more attention from physiologists than from chemists, and Dr. Michaelis's book is actually issued as the first volume of the series of monographs on physiology; but this does not detract from its value to physical chemists, and especially to those who are liable to be called upon to answer the conundrums of their biochemical colleagues.

### Phosphatic Fertilisers.

*Basic Slags and Rock Phosphates.* By Dr. G. Scott Robertson. (Cambridge Agricultural Monographs.) Pp. xvi+120. (Cambridge: At the University Press, 1922.) 14s. net.

**D**URING and since the war the position in this country with regard to the supply of basic phosphatic fertilisers has undergone a radical change. On one hand, the ousting of the older Bessemer process by the modern open hearth process of steel-making has led to the virtual disappearance from the market of the high grade basic slag to which the agriculturist was accustomed, and its replacement by a totally different material of much lower phosphorus content and frequently of low "citric-solubility." On the other hand, the development of the extensive deposits of rock phosphate in the Pacific Islands has rendered available greatly increased amounts of this material. The field experiments at Cackle Park, from which most of our knowledge of the value of basic slag in agriculture was derived, were carried out with the now obsolete high grade Bessemer material, and prior to Dr. Robertson's experiments practically nothing was known as to the fertilising value of the new open hearth slags; the experiments in this country on raw rock phosphate were also few in number and not very conclusive in result.

Dr. Scott Robertson's experiments were carried out on several different farms in various parts of Essex during the years 1915-20, and were designed to test the relative fertilising value of Bessemer and open hearth basic slag, and of mineral phosphates, on permanent grassland cut for hay. The results of these experiments form one of the most important contributions which have been made in recent years to the literature of phosphatic manures, and their publication in book form is thus very welcome. It was found that on heavy soils of the London Clay and Boulder Clay the improvement effected by rock phosphates compared favourably with that due to high-soluble basic slags, especially in a wet season when the hay harvest was late, and on sour soils. The low-soluble fluorspar slags were definitely inferior, though still effecting a considerable improvement. At two of the centres where the experiments were carried out there was no response to phosphatic manuring, and the author produces evidence that this is due to the operation of another limiting factor, probably deficiency of potash. This point is of interest in connexion with the fact, well known to agriculturists, that basic slag is not invariably effective on all grassland. It is quite likely that some, at least, of these failures are due to a similar cause.

Dr. Robertson did not restrict his work to the determination of the yields of hay on his plots. He presents interesting data on the botanical composition of the herbage, and on the effect of the phosphatic manures on such soil factors as moisture content, temperature, total nitrogen and nitrate content, bacterial numbers, and acidity, all of which, together with climate conditions, are considered in relation to their possible influence on the yields obtained.

Needless to say, the book is well printed and produced, but the price is high for a small volume and will certainly react unfavourably on its sale. This is regrettable, for it deserves a wide circulation among all interested in the improvement of our grasslands and in the country's agricultural production.

H. J. P.

### Our Bookshelf.

- (1) *Potash*. By Sydney J. Johnstone. New edition revised and enlarged. (Imperial Institute. Monographs on Mineral Resources, with special reference to the British Empire.) Pp. x+122. (London: John Murray, 1922.) 6s. net.
- (2) *Oil Shales*. By Dr. H. B. Cronshaw. (*Ibid.*) Pp. x+80. (London: John Murray, 1921.) 5s. net.
- (1) Mr. S. J. JOHNSTONE'S monograph on sources of potash is the most useful summary that has been produced since that written by Messrs. H. S. Gale and W. B. Hicks for the Geological Survey of the United

States ("Potash in 1917," published 1919). It has no index, but ends with an excellent bibliography, arranged in the sequence of references to the papers in the text. The author deals with all commercial sources of potash, including (p. 112) the product styled Karroo ash, a residue from the ignition of the sheep-dung used as fuel in the Karroo region of S. Africa. The attention now given to alunite is well reflected in the summaries on pp. 51 to 60. The methods of treatment are described, and it may be remembered that a research by W. T. Schaller, the mineralogist, led to the suggestion of the simultaneous extraction from alunite of potash and alumina for commercial purposes. The nomenclature in the analyses of products from the Alsatian mines on p. 12 does not agree with that adopted elsewhere in the text, and the use of "kainite," here and on p. 5, as a synonym for "sylvinit" is an obvious error. "Sylvinit" is, of course, a trade-name for a mixture of sylvine and rock-salt. It is surely time that "muriate of potash," as a name for a substance containing no potash, disappeared. On p. 5 the potassium-content of various products is given, calculated as potash, and the German and other salts are quoted as yielding 100 per cent. We believe that 12.4 per cent. was the official figure adopted by the German Potash Syndicate in 1921. The account of the occurrences of the ordinary soluble potassium salts seems the least satisfactory part of the present memoir. What, for instance, is meant (p. 11) by "the amount of potash averages 30 per cent. of potassium chloride" in the description of an Alsatian deposit?

(2) Dr. Cronshaw's review of oil-shale resources is valuable as a record of attempts to locate such shales by boring in England. Something seems to have gone astray in the account of the Ballycastle coalfield (p. 28), where the Scottish "Broxburn shale" and a place called "Newlygen" are introduced. The description of explorations and results in other countries shows how comparatively successful the industry has been in south-eastern Scotland, though even here the refineries are now to be supplied with imported oil. The author provides a good general and local bibliography.

G. A. J. C.

*Town Theory and Practice*. By W. R. Lethaby, G. L. Pepler, Sir T. G. Chambers, R. Unwin, and R. L. Reiss. Edited, with an Introduction, by C. B. Purdom. Pp. 139. (London: Benn Bros., Ltd., 1921.) 5s. net.

MR. PURDOM points out that, notwithstanding the frequent mention of "garden-cities" in the popular press, it is not generally understood that it is a technical term denoting a self-contained area set out upon a definite plan and including within its boundaries all the requisite elements for the life of an independent community, and that Letchworth and Welwyn alone conform to this definition. This little book on the theory and practice of the garden-city contains five essays which deal with various aspects of the question. Mr. W. R. Lethaby deals with the town itself in an essay of a general character; Mr. G. L. Pepler describes the town plan, showing how the garden-city endeavours to combine practical utility, the convenience of the workers and business undertakings, and aesthetic and hygienic considerations, and Mr. Raymond Unwin, in

discussing the best size of the town for good social life, considers, among other matters, the bearing of the number of the population upon the question of educational facilities and artistic development, such as music and the drama. Mr. Reiss raises some interesting points in connexion with land values and the possibility of co-operation with local authorities in the matter of rating and the development of municipal activities. For the use of those who wish to pursue the subject further, a bibliography is appended.

*Land and Sea Speed Reckoner.* Designed by Capt. W. N. McClean. (London: Constructed by C. T. Cooper and Sons, Ltd.) 11. 12s. 6d.

THIS is an instrument of the slide-rule type, which has of late years met with considerable favour among navigators for dealing with that class of problem in which an approximate solution is sufficient. By means of the instrument it is possible to obtain (1) speed, when distance and elapsed time are known; (2) elapsed time, when speed and distance are known; (3) distance, when elapsed time and speed are known. The slide-rule consists of two scales, namely, (a) a time scale, styled the "Slider," and (b) a distance scale, and by setting these in correct mutual relation any of the above problems can be dealt with in one simple operation. Thus, if elapsed time is  $8^m 40^s$ , while distance steamed is 3.2 miles, all that is necessary is to bring the graduations denoting these two values vertically opposite to each other, when the required speed, in this case 22.2 miles per hour, is read off on the distance scale, opposite the division on the time scale marked one hour.

A modification of the instrument, known as the "Air Speed Reckoner," has a specially adapted distance scale to meet the case of high speeds in the navigation of the air.

The manipulation of the scales is simple, and easy to grasp, and the invention seems well adapted to the purpose of dispensing with troublesome arithmetical calculations which the designer appears to have had in view.

*Diet and Race: Anthropological Essays.* By F. P. Armitage. Pp. vi + 144. (London: Longmans, Green and Co., 1922.) 7s. 6d. net.

MR. ARMITAGE discusses the relation of diet to stature, pigmentation, and head form. In reference to stature, after an analysis of the food values of staple articles of food in different parts of the world, he suggests that each is associated with a particular type of physique, and shows that scarcity of food is a concomitant of diminutive stature, and *vice versa*. In dealing with pigmentation, he shows that pigmentation varies with the amount of salt which enters directly or indirectly into the diet, the greatest quantity being consumed by the fairer races. The question of pigmentation is obscure, and although it is generally regarded as due to environment, it is not clear how variation has been brought about. It is not impossible that the chemical action set up by salt may be one of the factors involved. In regard to head form, the author suggests that the difference between long and broad heads may be due to the difference of muscular effort requisite in masticating soft and hard foods. The author does not appear

to be aware that a similar suggestion, both as to the effect of muscular action and as to the character of the food, was put forward by Prof. Arthur Thomson some years ago.

*Introduction à l'étude des fonctions elliptiques à l'usage des étudiants des facultés des sciences.* Par Prof. P. Humbert. Pp. 38. (Paris: J. Hermann, 1922.) 3 francs.

ELLIPTIC functions are not studied by mathematical students unless they are specialists in mathematical analysis, yet a knowledge of the most important elementary facts about these functions is essential for advanced work in many branches of pure and applied mathematics. Prof. Humbert's object is to supply this information in a conveniently brief form. Starting with the elementary theory of residues and contour integrals, the author introduces the notion of periodic functions defined by integrals: doubly periodic functions then follow, leading to the  $p$  function and some of its most useful properties. We then get the  $\zeta$  and  $\sigma$  functions, and finally modular functions are touched upon. The book forms a clearly written introduction which cannot but encourage the student to seek for further and more detailed information in standard treatises. S. B.

*On the Edge of the Primeval Forest: Experiences and Observations of a Doctor in Equatorial Africa.* By Prof. A. Schweitzer. Translated by Ch. Th. Campion. (London: A. and C. Black, Ltd., 1922.) 6s. net.

THE author resigned his professorship in the University of Strasbourg in order to qualify in medicine with the view of working among the natives of the French Congo. His work is an account of five years' experience at Lambarene on the Ogowe River. Prof. Schweitzer is evidently a close observer, and he succeeds in giving a vivid picture of the monotony of life in the oppressive luxuriance of the tropical forest. The considerable attention devoted to medical and surgical matters does not lighten the gloom. There are a few interesting reflections on some urgent tropical problems, such as the labour question and the relation between blacks and whites, which, in view of the author's experience, might with advantages have been expanded. The book is a short one, but not without value as a contribution to the study of the negro and his relations with the trader and missionary.

*Evolution of the Essex Rivers and of the Lower Thames.* By Prof. J. W. Gregory. Pp. 68. (Colchester: Benham and Co., Ltd., 1922.) 2s. 6d. net.

AS this book's geological contents occupy not quite sixty pages, and as "Bibliography and References" occupy three pages, and refer to fifty-nine different memoirs, or papers, on various points in Essex geology, it is obvious that no brief view of its conclusions is possible here. The views expressed as to the "Evolution of the Essex Rivers" and "The Relations of Essex and Midland River Systems," etc., are not antagonistic to those of previous writers, but are mainly occupied by matters more or less outside those treated by Essex geologists of an earlier date. In short, it is a brief work of much value to all students of Essex geology. T. V. HOLMES.

## Letters to the Editor.

[The Editor does not hold himself responsible for opinions expressed by his correspondents. Neither can he undertake to return, or to correspond with the writers of, rejected manuscripts intended for this or any other part of NATURE. No notice is taken of anonymous communications.]

## Spectrum Lines of Neutral Helium.

DR. SILBERSTEIN'S letter in NATURE of August 19, p. 247, induces me to write to say that some time ago I found the key for unravelling the constitution of the secondary spectrum of hydrogen to be of a kind similar to, though more generalised than, that used by him for helium. Practically the whole of this spectrum depends on the sequence of the Balmer series. If  $f(m)$  denote the  $m$ th sequent, the wave number of any line is of the form  $\sum k_{mf}(m)$ , where the  $k_m$  are positive or negative integers; e.g. the line  $n = 16892.72$  is  $f(2) - f(3) + f(4) - f(5) - f(6) + f(7) = H_\alpha + (H_\gamma - H_\delta) - (H_\delta - H_\epsilon)$  within an observation error  $d\lambda = 0.01$ . In fact the spectrum is a kind of linkage spectrum in which the usual links are replaced by the separations between the successive lines of the primary, namely, 5331.57, 2467.75, etc. The same machinery of analysis used for linkage spectra is then directly applicable, but as the total number of observed lines is about 1600 it may be understood that a considerable time is required for the completion, arrangement, and discussion of the various physical effects in different groups of lines. The preliminary work of forming the linkage maps is practically completed. The results so clearly suggested that Curtis's helium spectrum was built in the same way that I was on the point of writing to him to suggest his testing them, and now Dr. Silberstein's very interesting letter comes to show independently that this is the case.

It has always seemed to me that the existence of these linkage spectra forms a difficulty in the orbital theory of spectral lines. This difficulty Dr. Silberstein's theory does not meet. According to his theory, and apparently in any orbit theory, the two electrons are moving independently, and each passes between two of its corresponding paths. But if the combined change of energy is radiated, these two events must be absolutely simultaneous, and would happen, say, once in an æon.

W. M. HICKS.

August 19.

## Micro Methods in the Practical Teaching of Chemistry.

A CHANGE in teaching methods which brings with it simplicity and economy should appeal to all. May I therefore direct attention to methods I have myself begun in Cairo of teaching chemistry from the beginning by "microchemical" methods—that is, by working with very small quantities? (We really need a better word than "microchemical," which seems to suggest the microscope.)

It is strange that even in science we are so conventional. Pieces of apparatus once introduced by some one of repute remain in the shape and form, size and weight in which they were first employed as if they were consecrated objects. The Bunsen burner, for example, although it may be far bigger than required and very expensive in its consumption of gas, is scarcely ever changed. Even where a far less consumption of gas would suffice it seems to be the tradition to burn a large quantity. It is the same with the size of the test tube, beaker, or flask in

common use, and the same also with the quantity of material used by the student in carrying out his chemical tests: he will as a rule take a quarter, if not a half, test tubeful of some solution and add as much of the testing reagents as he can get into the test tube. There seems to be no necessity for these large quantities, and most of the tests carried out by students in chemical laboratories could be done with far less material. I propose to describe some of the methods which have been used in the Government Medical School Chemical Department, Cairo, during the past year, feeling that many laboratories would gain much in time, materials, and money by following methods which have proved very successful there.

These methods arose out of necessity. Too many students and too little space is probably a state of things not special to Cairo; the extreme was reached when it became necessary to teach two hundred students without any proper laboratory at all. Rather than refuse admission to the students a solution of the difficulty was sought in microchemical methods, and the result was successful beyond anticipation. Many who visited the laboratory at the time were surprised to see a hundred students seated in perfect silence busily engaged in applying microchemical methods in a hall in which there was neither water nor gas nor any of the appurtenances of a chemical laboratory. The necessity for such an improvisation could scarcely arise under more settled conditions, nor for that reason is it likely that any one would have the opportunity of carrying out such a teaching experiment on so large a scale.

The root idea of the method is economy in its broadest sense: in time, labour, and materials. Clearly if the student uses nothing larger than a drop instead of the habitual inch or half-inch in a test tube the expense in chemicals can be readily reduced one hundredfold. The expense in students' chemicals represented during the year only a few pounds of materials, the consumption of most of which is to be attributed to second-year students doing special work. About 500*l.* has been saved out of chemicals alone, which saving can be applied to the purchase of permanent apparatus.

The economy in apparatus has been even greater than in chemicals. The bottles throughout the laboratory have been reduced to one-tenth of the conventional size. Each student is given at first a small rack, and later another, containing six reagent bottles of one ounce capacity. These bottles are unstoppered but fitted with small dropping-pipettes. The bottles are cheap and the pipettes are made in the laboratory. The racks are easily collected and stored, and it is possible in this way to keep a class constantly supplied with freshly prepared solutions by issuing only those reagents which it is intended to employ at the time, thus avoiding the making up at the beginning of term of large quantities of solutions which may not be required till many months later. No test tubes are used till the student comes to actual separation of the groups, so that for the first half of the course all the expense and annoyance of breakage, difficulties of cleaning, and mess due to test tube work on the benches is avoided.

Indiscriminate test-tubing by students untrained in delicate manipulation and without any quantitative sense is, as it seems to me, a bad influence in their training which it is important to combat. In so many schools has it been the custom to use materials in wastefully large quantities that the name "stinks" only too aptly describes what goes on. But if the student be taught from the outset to regard the drop as a suitable, if not already a large quantity, he will get nearer to the quantitative notion and may acquire some of that delicacy of manipulation so essential to

his proper training; and when he comes to use larger quantities of materials and more expensive apparatus he is more likely to do so with economy and care.

In the early part of the work many simple substitutes for the test tube may be used, and there is an advantage in variety, the chief of many considerations being the ease with which such things are washed: a glass slide, as used for the microscope, or any small piece of glass is suitable—for it may be rapidly cleaned after each drop-experiment—and the drop may be studied with the pocket lens, enabling the student to distinguish between crystalline and amorphous precipitates and to note whether the colour is in the precipitate or the solution; indeed the training of the student in the use of the pocket lens from the very outset is highly desirable. Other materials are porcelain tiles or broken china, readily replaced by the student himself. A third class of material, very convenient and possessing certain advantages in chemical tests, is filter-paper or some form of absorbent paper, or in its absence white paper of any kind. When a reaction takes place in a drop on filter-paper, the separation of the precipitate from the solution becomes even more obvious than when the same reaction takes place on a tile or piece of glass. He may learn something also about surface tension, adsorption, and the difference between crystalloid and colloid, and many elementary physical facts which he would never learn by the test tube method.

There are very few reactions commonly carried out in the chemical laboratory which cannot be carried out just as well or better in the microchemical way; for example, the reduction of a copper solution by an aldehyde. Let the student place several separate drops of Fehling's solution on a glass slide and to each add a drop of some different aldehyde solution; let him warm the slide gradually over a small flame and make comparison of the changes in the several drops. This is an example of an experiment of a simple kind where an attempt is made to obtain constant conditions, varying only one factor. Such instructive little tests as these are surely worth far more than mere colour or precipitation tests in test tubes. Many more such tests could be described, but each teacher will probably prefer to devise experiments of his own, suited to the needs of his class.

It is submitted, therefore, that microchemical methods form not only an excellent introductory training for the student but mean a great saving in time, labour, and money. We have saved in one year at least 1,000*l.*, enabling us to buy more apparatus of a permanent kind for teaching and research.

EGERTON C. GREY.

Government Medical School,  
Cairo, July 1922.

### An Atomic Model with Stationary Electrons.

BOHR's atomic model with its circling electrons appears at first sight quite incompatible with Langmuir's model; in which the electrons are stationary or oscillate about fixed positions of equilibrium. Dr. Langmuir himself, however, has pointed out that a static atom possessing many of the properties of the Bohr atom is impossible provided a force of repulsion equal to  $F = 1/mv^3 \cdot (nh/2\pi)^2$  act between an electron (mass  $m$ , charge  $e$ ) and a nucleus. Here  $n$  is an integer and  $h$  is Planck's constant. The distance  $r$  of the electron from the nucleus in stable equilibrium is the same as the radius of a circular orbit corresponding to a stationary state in Bohr's theory. The total energy of the electron is also the same as that given by Bohr's theory. The frequency of oscillation about

the position of equilibrium is identical with the frequency of revolution of the electron in the Bohr atom. Thus the Rydberg constant and the Balmer series can be deduced without assuming moving electrons.

I wish to direct attention to the fact that a force of exactly the type required in Langmuir's theory is provided by the quantum mechanism recently described by Prof. E. T. Whittaker in the Proceedings of the Royal Society of Edinburgh. The mechanism may be pictured as a magnetic wheel consisting of a number of magnetic poles (total strength  $M$ ) revolving in a circle of radius  $a$ . When this magnetic wheel is rotating about its axis with angular velocity  $\omega$ , it sets up an electric field such that an electron situated at a point on the axis at a distance  $r$ , large in comparison with  $a$ , is acted on by a force  $Mea^2\omega/r^3$  along the axis. Prof. Whittaker has shown that the angular momentum of the magnetic wheel in its steady state (after the passage of an electron completely through it) is determined by  $A\omega = 2eM$ , where  $A$  is the moment of inertia of the wheel. We shall assume that, in general, the angular momentum is given by Nicholson's quantum relation, so that

$$A\omega = 2eM = nh/2\pi.$$

Substituting the values of  $Me$  and  $\omega$  thus found in the expression for the force on the electron, we find that the "quantum force" is given by

$$\frac{a^2}{2Ar^3} \left( \frac{nh}{2\pi} \right)^2.$$

This agrees precisely with Langmuir's expression for the force of repulsion, provided we make the single additional assumption that  $A = \frac{1}{2}ma^2$ .

Thus we see that by means of Prof. Whittaker's quantum mechanism it is possible to construct an atomic model which will yield many of the results of Bohr's theory, without employing moving electrons. I have discussed the question more fully in a paper to be published by the Physical Society of London.

H. S. ALLEN.

August 15.

### The Variable Depth of Earthquake Foci.

PROF. H. H. TURNER has given reasons (Mon. Not. R.A.S., Geophys. Suppt. No. 1) for believing that the depths of the foci of earthquakes differ among themselves by quantities up to about 300 km. It may be pointed out that this is precisely what may be expected from the theory of a cooling earth. The available information concerning the thermal state of the earth indicates that the rocks in the asthenosphere, at depths of 400 km. and more, must be very much weaker than those at the surface; this is amply confirmed by the geodetic evidence collected by Barrell, which also suggests that the rocks at depths comparable with 100 km. are considerably stronger than those at the surface. Accordingly, whatever may be the cause of crustal deformation in the earth, yield will occur in the asthenosphere for smaller stresses than are necessary to produce it in the upper parts of the crust. Thus the earthquakes arising from fractures below 400 km. would be more numerous but much less violent than those occurring at higher levels, and the greatest earthquakes should have their foci at the depth of greatest strength. We should therefore expect that the depths of earthquake foci may range from zero to 200 or 300 km.

DOROTHY WRINCH.  
HAROLD JEFFREYS.

August 21, 1922.



### An Electrical Analogue of the Vocal Organs.

In connexion with correspondence which recently has appeared in the columns of NATURE relating to the physical characteristics of vowel-sounds, the following account may be of interest of an apparatus believed to be novel, which is conveniently capable of the artificial production of many speech-sounds. It is well known that Helmholtz succeeded in imitating vowels by combinations of tuning forks, and Miller by combinations of organ pipes. Others, notably Scripture, have constructed apparatus wherein the transient oscillations of air in resonant cavities were excited by series of puffs of air, in close physical imitation of the action of the human vocal organs. It seems hitherto to have been overlooked that a functional copy of the vocal organs can be devised which depends upon the production of audio-frequency oscillations in electrical circuits.

A schematic diagram of such an apparatus is given in Fig. 1. Periodic interruptions of the electric current, produced by a buzzer or a motor-driven circuit interrupter, corresponded to the periodic inter-

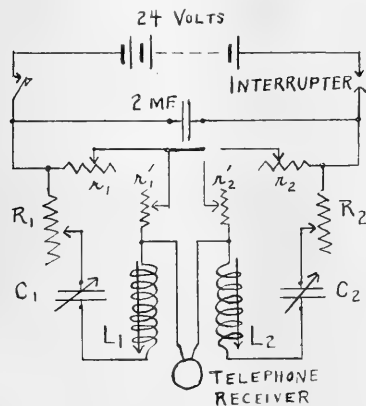

Fig. 1.

ruptions of the air current in the human throat by the vocal cords. The intermittent electric current thus produced excited the natural damped oscillations of the resonant circuits, 1 and 2. This was confirmed by observation with an oscillograph. In like manner, puffs of air from the vocal cords excite the natural damped oscillations of the air in the mouth cavities. The work of numerous investigators has indicated that the air in the mouth cavities possesses, as a rule, only one or two important modes of vibration. The oscillations of the electric current were transformed to sound-vibrations in the air by a loosely coupled telephone receiver. The distortion introduced by this telephone receiver appeared to be of little importance.

Appropriate adjustments of the resonant circuits 1 and 2 were observed to result in the production of all the various vowels and semi-vowels in turn. Alteration of the frequency or damping of either resonant circuit was observed to result in alteration of the vowel produced. The frequency of interruption, which was the group frequency of the recurrent damped oscillations, was observed to determine the pitch of the vowel; but it did not determine what vowel was produced. Similarly, in the case of the human voice the frequency of vibration of the vocal

cords is known to determine the voice-pitch, while the adjustment of the mouth cavities is known to characterise the vowel.

The vowels and semi-vowels produced by the "electrical voice" with regular interruptions, in the manner just described, were equivalent to intoned or sung vowels, or, if the frequency of interruption was made to vary appropriately, to spoken vowels. It was found possible to produce the whispered vowels with interruptions that were non-periodic, which is in accordance with the idea that, in the human voice, whispered speech is due to irregular frictional modulation of the exhaled air. Whether the vowel was whispered, sung, or spoken depended upon the manner of making the interruptions; while what particular vowel was produced depended upon the adjustment of the resonant circuits.

Diphthongs were produced by altering the circuit adjustments rapidly so as to shift from the initial to the final vowel-sound of the diphthong pair. Some of the fricative (hissing) consonants were approximated with irregular interruptions, provided the resonant circuits were set at somewhat higher frequencies than for the vowels and semi-vowels. None of the explosive consonants were satisfactorily imitated. It is believed that lack of success with the explosives was due to obvious difficulties of manipulation.

There was much room for improvement with respect to the naturalness of the "electrical voice." It was too monotonous, as was to have been anticipated. Contrary to expectation, alteration in the wave-form of the exciting current did not materially change the tone, provided the wave-form was sufficiently far from sinusoidal. The intoned vowels, semi-vowels, and diphthongs produced by the "electrical voice" were sufficiently natural to be recognised in at least fifty per cent. of the trials by eight or ten different observers. When arrangements, not indicated in Fig. 1, were made to give the appropriate circuit adjustments in rapid succession, simple words like "mama," "Anna," "wow-wow," "yi-yi," were fairly well imitated. The whispered vowels and fricative consonants were not imitated so well, because (it is thought) of the lack of complete irregularity in the circuit interruptions. In human speech the pitch and vowel quality and intensity are constantly changing in a way difficult to imitate with the crude apparatus of Fig. 1. Probably, also, in the human voice additional weak transient oscillations are excited, due to minor modes of vibration of the air in the cavities of the head, which determine the individuality of the voice without greatly altering the speech-sounds.

Thus these experimental results are sufficient to give a general qualitative description of each of the following four classes of speech-sounds: vowels, semi-vowels, diphthongs, and fricative consonants (but not explosives), whether sung, spoken, or whispered; and these results also make possible quantitative specification of the characteristics of the various speech-sounds themselves. Numerical values of the frequencies and dampings which appear to characterise the various speech-sounds have been calculated from the electrical constants possessed by the resonant circuits of the apparatus when adjusted to produce them.

The analytical expression for a single transient due to one resonant circuit when loosely coupled is, of course,

$$z \text{ Instantaneous displacement} = Ae^{-at} \sin 2\pi ft,$$

where  $e$  is the base of natural logarithms,  $a$  the damping constant,  $f$  the frequency, and  $A$  the amplitude. The displacement in the air-vibration is taken as proportional to the instantaneous current. Also,  $f = 1/2\pi\sqrt{LC}$  nearly, and  $a = R/2L$ . The capacity  $C$

of each resonant circuit was variable in steps from 0.001 to 2 microfarads. The inductance L was continuously variable from about 0.3 to 0.7 henry. The resistance R was due largely to a dial box of range 1 to several thousand ohms, and included, in addition, the resistance of the inductometer and the (perhaps 100 ohms) small variable coupling resistances  $r$  and  $r'$  (Fig. 1).

The nature of the numerical results is indicated in Table I, which gives approximate values of the frequencies and dampings of the recurrent oscillations which characterise six of the more important vowels. Group frequencies (that is, voice pitches) were for each vowel varied over the range 75-300 per second. The first three vowels given in this table are each characterised by a single train of recurrent damped oscillations; the remaining three are characterised by two trains of recurrent damped oscillations. The numerical values are approximate. Indeed, considerable changes in the circuit adjustments in some cases do not materially alter the vowel produced. The problem of determining the permissible range of variation for each speech-sound requires further study. For the latter three vowels the relative values of  $r_1$  and  $r_2$  are of some importance.

TABLE I.

Vowel.	Damping Oscillations.	
	Frequency, $f$ . (Unit of Time, one second.)	Damping constant, $a$ . (Unit of Time, one second.)
ru $\ddot{d}$ e . . . . .	320	small (< 50)
law . . . . .	650	100
fath $\ddot{e}$ r . . . . .	1000	500
mat . . . . .	{ 750 1500	{ 800 800
pet . . . . .	{ 420 2300	{ 50 50
cede . . . . .	{ 320 2500	{ 50 50

These results seem sufficiently interesting to recommend the apparatus of Fig. 1 to the attention of students of speech-sounds. Although simple in construction, this apparatus possesses considerable flexibility and range. The really difficult problem involved in the artificial production of speech-sounds is not the making of a device which shall produce sounds which, in their fundamental physical basis, resemble those of speech, but in the manipulation of the apparatus to imitate the manifold variations in tone which are so important in securing naturalness.

As for the disagreement between the Helmholtz-Miller, or steady state theory of vowels, and the Willis-Hermann-Scripture, or transient, theory, Rayleigh pointed out that the conflict was only apparent. The disagreement concerns methods rather than facts. Which view-point should be adopted is thus a matter of convenience in a given case. When the transmission of speech over telephone circuits is in question, for example, the steady state theory often possesses obvious mathematical advantages. On the other hand, the quantitative data relating to the physical nature of vowels which are given in Prof. Miller's well-known book, "The Science of Musical Sounds," expressed, as they are, in terms of the steady state theory, are less compact and definite than the data of Table I, which are expressed in terms of the transient theory. The general agreement between the two sets of data is, of course, obvious.

The work described in this communication was performed while the writer was associated with the American Telephone and Telegraph Company, and was carried out in the laboratories of that company and of the Western Electric Company, Inc.

JOHN O. STEWART.

Princeton University, Princeton,  
New Jersey, July 8.

NO. 2757, VOL. IIO]

### Interspecific Sterility.

DR. GATES, in his letter which appears in NATURE for August 5, p. 179, emphasises the importance of tetraploid species in evolution, and with this position I heartily agree. Nevertheless, I do not think that the difficulties in the way of free crossings amongst diploid, tetraploid, and hexaploid species are so great as seems at first sight probable, at any rate in the Salicaceae.

In this order Miss Kathleen B. Blackburn and myself have been conducting cytological researches for some time, and find the fundamental chromosome number, both in *Populus* and *Salix*, to be nineteen. Up to the present only diploid species have been encountered in the first-named genus, but in *Salix*, on the contrary, diploid, tetraploid, and hexaploid forms have revealed themselves. In this communication I wish more particularly to direct attention to that homogeneous assemblage known as the Capreae group, which includes, in the eyes of most salicologists, three genuine species, *Salix caprea*, *S. cinerea*, and *S. aurita*—an arrangement entirely in harmony with my own views. Still, so closely related are these three plants that many botanists, both British and continental, have refused to see in them more than one polymorphic species; similarly, others, although they admit the distinctness of *S. aurita*, combine *S. cinerea* with *S. caprea*. Despite this, *S. aurita* and *S. cinerea* manifest themselves cytologically as purely tetraploid species, while *S. caprea*, in the main a diploid form, possesses a tetraploid race indistinguishable in the field from the commoner and normal diploid type. Furthermore, what is especially noteworthy, any one of these four forms can be crossed readily with the other three, and the  $F_1$  hybrids thus obtained prove perfectly fertile *inter se*. Not only is this the case, but, in addition, other species can be brought into the chain, as, for instance, in the complex cross [(*Salix purpurea*  $\times$  *S. viminalis*)  $\times$  *S. cinerea*]  $\times$  *S. caprea* (tetraploid), produced in my garden, and in the still more complicated hybrid [(*S. cinerea*  $\times$  *S. purpurea*)  $\times$  *S. aurita*]  $\times$  [(*S. viminalis*  $\times$  *S. caprea*)  $\times$  (*S. viminalis*  $\times$  *S. phylicifolia*)], secured by Heribert-Nilsson: in the former, two diploid and two tetraploid species have taken part, and in the latter, three (or two) diploid, two (or three) tetraploid, and one hexaploid form.

As a matter of fact, in the genus *Salix*, interspecific sterility depends, not on the chromosome complement of the species concerned, but on the physiological divergence of the groups to which they happen to belong. Experiments designed to cross the diploid *S. triandra* with the diploid *S. purpurea* turn out just as fruitless as similar attempts to hybridise it with the tetraploid *S. cinerea* and the hexaploid *S. Andersoniana*; on the other hand, the hybrid combinations between it and the tetraploid *S. alba* and *S. fragilis* can be obtained with the utmost ease.

J. W. H. HARRISON.

Armstrong College, Newcastle-upon-Tyne.

August 8.

### The Mass-spectrum of Iron.

I HAVE recently investigated this element by using the vapour of its penta-carbonyl mixed with carbon dioxide. It is even more troublesome to deal with than the corresponding nickel compound, but by employing intense discharges and long exposures fairly satisfactory results have been obtained.

The mass-spectrum of iron is characterised by a strong line, approximately at 56, and it may be con-

cluded with absolute certainty that this line is due to the predominant constituent of the element. Refined measurements indicate a value rather less than this integer. The mean of some sixteen independent and very consistent comparisons with lines due to mercury and compounds of carbon and oxygen works out at  $55.94 \pm 0.05$ .

The accepted chemical mean weight, 55.84, suggests the presence of a lighter isotope, and a general consideration of elements already analysed points to the value 54 as the most probable. A very faint line is, indeed, visible in all cases where the 56 line is really strong, but it is impossible to make certain that it is due to iron. Further, if we accept the difference of the above figures as exact and assume 54 to be the only lighter constituent, this line should have about one-twentieth the intensity of the 56 line; actually its intensity appears much less.

Iron may therefore be taken as being almost, if not entirely, a simple element of atomic weight, approximately 56. It may contain a small proportion of an isotope 54, but this is by no means certain.

F. W. ASTON.

Cavendish Laboratory, Cambridge,  
August 26.

#### Density of Adsorbed Films.

WHEN a very small quantity of such a liquid as castor oil is placed upon a clean surface of water dusted with talc, it spreads over the water surface, brushing the talc on one side, and forms an invisible circular spot, the size of which depends upon the amount of oil used. This adsorbed film has the same surface tension as the surrounding water surface, namely, 73 dynes per cm. Hence Devaux, Langmuir, and others regard the film as being only one molecule thick.

If such an invisible film of castor oil be contracted, the surface tension decreases until it falls to about 57.2 dynes per sq. cm. Further contraction does not much reduce the tension. Marcellin was of opinion that as the diameter of the film was decreased, it thickened until it was two molecules thick, and that when this occurred, the film had the same surface tension as castor oil in bulk. But the amount of contraction the surface undergoes in the case of castor oil is only about 40 per cent., and this Devaux points out is not sufficient to make the film two molecules thick, and he suggests that these thicker films are not two molecules thick, but are monomolecular films with *closer packing* of the molecules. On this view the film of limited area surrounded by water is stretched until its tension reaches that of a clean surface of water.

If the above explanation be correct, it is clear that the density of the stretched film of oil having a surface tension of 73 dynes per cm. must be considerably less than that of the same film when its surface tension is only 57.2 dynes per cm.

Now when calculating the dimensions of the molecules of various substances, by the surface tension method, I gather that Devaux and Langmuir regard the oil films, when they are stretched by the surrounding water surface, as having the same density as the liquid in bulk. Would it not be safer to assume that the density of the film, when it has the same surface tension as the oil in bulk, is more nearly equal to that of the oil in bulk? The point is one of considerable interest and importance, and well worthy of consideration.

R. M. DEELEY.

Tintagil, Kew Gardens Road,  
Kew, Surrey.

NO. 2757, VOL. 110]

#### The Pigeon Tick.

WE wish to record the occurrence of the pigeon tick, *Argas reflexus*, in Cambridge, where it is parasitic on the pigeons which breed between the inner and outer roofs of King's College Chapel. On August 4 we found a specimen, which Mr. C. Warburton was kind enough to identify for us. This specimen is now in the collection of the Molteno Institute of Parasitology. On a later date we found six more individuals.

The parasite seems to have been found previously in the British Isles in Canterbury Cathedral only, and not at all since 1908. This new locality, therefore, may indicate that it will be found elsewhere if searched for carefully.

The adult tick is not permanently attached to its host, but hides in crevices in masonry and woodwork, leaving its hiding-places to feed at night.

L. H. MATTHEWS.

A. D. HOBSON.

Zoological Laboratory, Cambridge.

#### An Ancient Wasp.

I HAVE just received from Mr. John P. Byram a small collection of fossil insects which he obtained at the head of Bear Gulch, 12 miles from Una, Colorado. The formation is Green River Eocene, and Mr. Byram states that the material comes from a lower stratum than the insects previously obtained by us. One of the specimens is a beautifully preserved wasp, with wings outspread, belonging to the modern genus *Hoplisus*. It is 12 mm. long, with a wing-spread of about 19 mm.; the head and thorax are black; abdomen fusiform with narrow base, and the hind margins of the segments broadly pale-banded, as in living species; the legs are colourless, probably yellow originally; the anterior wing shows a pallid stigma, and a strong dusky cloud including the basal part of the marginal cell and the whole of the second submarginal; the venation is essentially that of the modern *Hoplisus quadrifasciatus*, except that the marginal cell is more slender, and in the hind wing the cubitus practically meets the nervellus.

The only fossorial wasp from the Eocene previously described is Scudder's *Didneis solidescens*, which is evidently quite different from the present species, but is too poorly preserved for the accurate determination of the genus. No older wasps are known.

This Eocene *Hoplisus*, which may be called *Hoplisus archoryctes*, doubtless preyed on the Homoptera, which are so numerous in the same rocks. It is, I think, the most impressive instance of the persistence of type which I have ever seen, when we consider that it belongs to a highly specialised group of insects, and proves that within this group there has, at least in one line, been no change of form or colour in the many millions of years which we now believe to have elapsed since the Eocene. Even the cloud on the wings is as in living species. Could the species be restored to life, *H. archoryctes* would fall into our system, merely forming another species to be added to the many similar ones existing.

T. D. A. COCKERELL.

University of Colorado, Boulder, Aug. 1.

#### Black Coral.

PROF. HICKSON'S very interesting article on the therapeutics of Black Coral (*NATURE*, August 12, p. 217) is sure to stimulate further study, and it is therefore worth while remembering that in alchemical terminology corals are sometimes used as a pseudonym for antimony.

M. NIERENSTEIN.

University of Bristol, August 13.

## The Zoological Society.

By E. G. BOULENGER.

BEFORE the foundation of the Zoological Society of London in 1826 there was no organisation in this country devoted solely to zoological science. The Royal Society, as it still does, occasionally published papers of zoological interest, while the Linnean Society, which undertook the discussion of both zoological and botanical subjects, at this time rated the latter science of more importance than the former. As to the exhibition of living animals, during the first quarter of the nineteenth century the only collections in the country were those of the Royal Menageries at Windsor and at the Tower, and the private one of Mr. Cross at Exeter 'Change' in the Strand. Hence it came about that a band of enthusiastic zoologists headed by Sir Stamford Raffles, who had just returned from administrative duties in the East Indies, decided on founding a Zoological Society in London. At the first general meeting, held in the rooms of the Horticultural Society in Regent Street, which was attended by more than a hundred persons, Sir Stamford Raffles was elected president. Unfortunately the president and founder died a few months later—some years before the society acquired its charter of incorporation, granted in 1829, in which the Marquis of Lansdowne is named as the first president of the chartered society, and Mr. N. A. Vigors the first secretary.

Twenty acres of ground in Regent's Park having been obtained from the Government at a nominal rent, the gardens were laid out in accordance with the plans of Decimus Burton, and opened in 1828 with a stock consisting of 152 mammals and 475 birds. The first animals to come into the possession of the society were housed at the offices in Bruton Street, where they were kept until suitable accommodation had been provided for them in the gardens. The first animal to be received was a griffon vulture, which lived in the menagerie for forty years. While the menagerie was being formed in Regent's Park the society was engaged in establishing a museum of preserved specimens in Bruton Street. The museum attracted so many donations, becoming in consequence so crowded, that in 1836 more commodious quarters were taken for it in Leicester Square. In 1843 the collections were transferred to the gardens, and housed in a building on a site now occupied by the society's offices. Indeed, in the early days of the society the museum was regarded as the centre of the society's usefulness. When, however, the zoological department of the British Museum developed, the absurdity of endeavouring to maintain an inferior collection in the same city became apparent, and in 1856 it was decided to part with the collection and present the type specimens to the national museum.

The establishment of a farm at Kingston was another of the society's early enterprises. Its object was to give accommodation to animals requiring a greater range and more quiet than the gardens in Regent's Park could afford. It was also considered necessary for the purpose of breeding, and rearing young animals, and especially for attempting to naturalise such species as were hitherto unknown in this country.

This experiment was a costly failure, and was abandoned in 1836.

In the infancy of the society there were no scientific meetings, communications on subjects of zoological interest being submitted at the general meetings. In 1829 a special committee of science and correspondence was formed, at the meetings of which zoological subjects were discussed. The committee met until 1832, when an alteration was made in the by-laws by which the committee meetings were replaced by general meetings for the discussion of scientific business. These were held first at Bruton Street, but in 1843 the society moved to No. 11 Hanover Square, where it remained for forty years. In 1884 more commodious premises at No. 3 of the same square were acquired, and the meetings were held there until 1909, when the society moved to its present premises in the gardens.

The principal features of the gardens at its opening consisted of a lodge on approximately the site of the present main entrance, where visitors provided with a fellow's order paid a shilling for admission; a bear pit which still existed fifteen years ago on the site of the terrace, built in 1843; a yard for kangaroos on the site of the present eland paddock; sheds for deer and goats, and dens for large "quadrupeds"—tenanted by a lion, a tigress, a pair of leopards, a puma, a hyæna and a pair of polar bears on the site of the Lion House; a Monkey House with poles outside to which the monkeys were fastened during the summer months, on the site of the recently demolished otter pond; an enclosure for emus where the pelican enclosure now stands; paddocks for cranes and other large birds on the site of the present Eastern Aviary; an aviary for small birds, renamed the Crescent Aviary, which was demolished only last year, on the site of the new tea pavilion; and a Llama House with clock tower, the present Camel House, which alone of all the original houses and enclosures stands where it did in 1828. Just north of the Llama House was a yard with cages which housed a hybrid between a jackal and a dog, some bears, dingos, and a sable. On the site of the present Llama House were cattle-sheds containing an American bison. Towards the close of the year 1829 the tunnel connecting the south and the middle gardens (then called north garden, the present north garden being acquired at a much later date) was built, and a repository was constructed on the site of the present offices. The repository served for the reception of the animals on their arrival, and in turn has been converted into a reptile house, a museum, a small cats' house, and a squirrel house.

The gardens soon acquired great popularity, the annual admissions between the years 1830 and 1840 averaging more than 200,000. From the year 1840 the income of the society gradually decreased until in the year 1847 there were only 88,500 visitors. In that year Mr. D. W. Mitchell was appointed the first paid secretary, and with the general change of policy which he introduced matters immediately improved. To Mr. Mitchell, who held office till 1859, when he took up

the directorship of the Jardin d'Acclimatation, then just founded in Paris, were due the abolition of the rule which required that all visitors should be provided with a fellow's order, and the policy of admitting the public on Mondays, and children at any time for sixpence each. On Mr. Mitchell's retirement, Dr. Philip Lutley Sclater was elected to the post of secretary, which he held until 1901. During the lengthy period that he held office many changes were effected in the gardens, the most important being the erection of the Antelope House

office of secretary for a short period, but at the following annual meeting, on a vote of the fellows, the present secretary, Dr. P. Chalmers Mitchell, was elected to the post. Just prior to the retirement of Dr. Sclater some dissatisfaction had been expressed by a number of fellows with the housing conditions in the gardens, and the new secretary was soon at work, carrying out various improvements which gave immediate satisfaction to the fellows and public.

Apart from realising the necessity of doing away

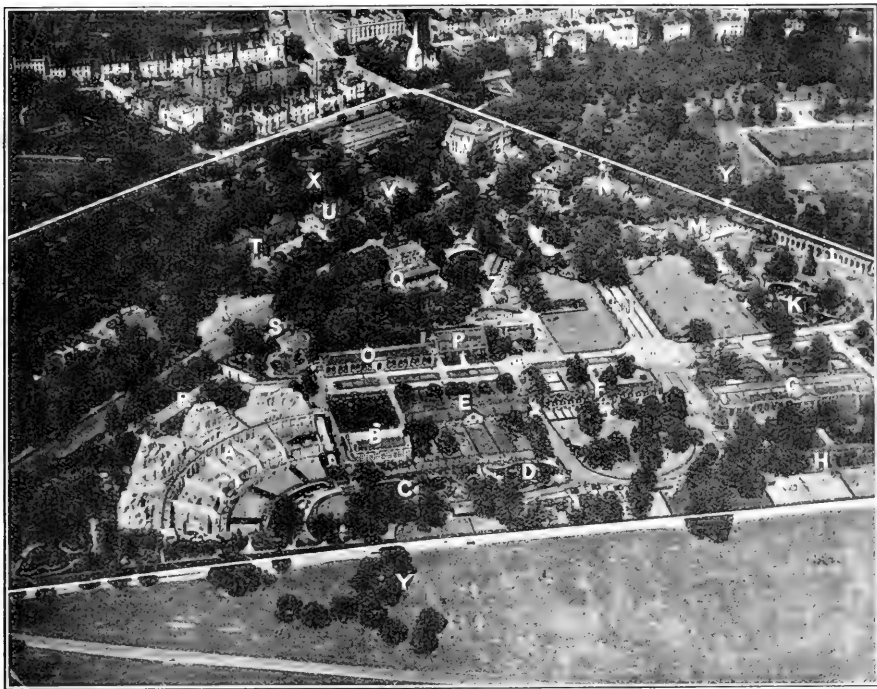

THE ZOOLOGICAL GARDENS, REGENT'S PARK, LONDON.

- A—MAPPIN TERRACES. B—ANTHROPOID APE HOUSE. C—SOUTHERN AVIARY. D—SEA LIONS' POND. E—OSTRICH HOUSE.
- F—ANTELOPE HOUSE. G—LION HOUSE. H—WOLVES' AND FOXES' DEN. J—ELEPHANT RIDG. K—THIEF ISLAND POND.
- L—BIRDS OF PREY AVIARIES. M—REFRESHMENT ROOMS. N—SMALL CATS' HOUSE. O—MONKEY HOUSE. P—SMALL BIRDS' HOUSE.
- Q—EASTERN AVIARY. R—WESTERN AVIARY. S—MAIN ENTRANCE. T—ELEPHANT HOUSE. U—PARKETS' HOUSE.
- V—CAIRD INSECT HOUSE. W—OFFICES AND LIBRARY. X—REGENT'S CANAL. Y—REGENT'S PARK. Z—CLOCK TOWER AND CAMEL HOUSE.

(1861), the Eastern Aviary (1862), the Monkey House (1864), the Elephant House (1868), the Lion House (1876), the old Insect House (now the Rodent House) (1881), the Reptile House (1887), the Ostrich House (1897), the Llama House (1898), the Zebra House (1899), and the Ape House (1901), all of which are still standing and are to be distinguished on the accompanying aero-photograph. Towards the end of the year 1901 Dr. Sclater retired after serving the society for forty-three years, a period during which the society occupied a very high position in the scientific world. On his retirement his son, Mr. W. L. Sclater, held the

with various small cages, and giving their inmates more exercise, Dr. Chalmers Mitchell, in spite of some opposition, insisted that many of the animals, which hitherto had been confined all the year round in very hot cages, should be given access to the open air. It was then the general belief that most of the creatures coming from the tropics should be kept very warm, and consequently their housing conditions were determined almost solely by considerations of temperature. Now visitors to the gardens in winter may see a host of tropical animals in the open, a change of policy which has had the effect of improving greatly the

general health of the exhibits. The secretary also realised that in the past, when new buildings and enclosures were erected, in most cases immediate convenience took precedence of any general scheme. In 1909 he induced the council to consider the condition of the gardens with regard to existing buildings of a permanent character, and recommended that in the future, as buildings and enclosures were erected, they should be arranged in conformity with a general plan. The matter was temporarily shelved, but in 1912 the garden committee drew up a list of the animals the society could expect to exhibit under suitable conditions at any time, considered the existing accommodation, deciding how far it was to be regarded as satisfactory, and what areas should be reserved for the supply of further accommodation as it could be provided. It is in conformity with the plan then drawn up that the various buildings and open spaces provided in recent years have been erected and set out.

In 1906 and in 1907 the society obtained additional grants of land from H.M. Commissioner of Works. The 20 acres of land granted to the society in 1826 lay on both sides of the Outer Circle, corresponding roughly with the existing middle and south gardens, but only a portion to the south of the circle was laid out. In 1834 an additional plot of ten acres on the south-west border of the gardens was obtained at an annual rental, on the condition that it was to be used as pasturage. In 1839, use of the land north of the Regent's Park Canal, corresponding to the existing north gardens, was granted.

In 1841 the ground in the occupation of the society was rearranged. The strip on the north bank of the canal was surrendered, and a portion at the east end of the middle garden was exchanged for a corresponding area at the west end, and permission was given to extend the works over the ten acres granted in 1834. In 1869 the land on the north bank of the canal was again taken over by the society. A considerable portion of the north garden was, however, not made use of until after 1903, when the policy of increasing open-air facilities for the animals was put into operation. Complete use of the north garden was, however, not possible until 1906, when the right-of-way was obtained

over two unoccupied portions of ground on both sides of the canal, and H.M. Commissioner of Works agreed to allow half of the new bridge over the canal to be used by the society on payment of its proportion of the cost of reconstruction. A communication between the north and the middle gardens was thus obtained. In 1907 a strip of ground was obtained along the south-west boundary of the south garden, which ends in a large triangular area at the west end, now occupied by a pond for water-fowl, and goose paddocks. The condition attached to the grant of the new piece of land was that the animals placed on it should be visible to the public in Regent's Park. The paddocks erected on this site now contain deer, llamas, emus, and rheas.

Of the buildings erected and designed under supervision of the present secretary, the Small Cats' House (1903), the Sea-Lions' Pond (1905), the Small Birds' House (1905), the Cattle and Deer Sheds (1906), the Society's New Offices and Library (1909), the Sanatorium (1909), the New Prosectorium (1909), the Mappin Terraces for the open-air display of mountain goats and bears, with its tea-pavilion (1913), the Small Mammal and Caird Insect House (1913), and the New Tea Pavilion facing the broad walk (1922), are the most important. The transfer of the offices, library, and meeting room to the gardens, apart from providing adequate accommodation for the library, which had outgrown the rooms in Hanover Square, has greatly facilitated the work of the staff. At the time there was some opposition to the transfer, a few fellows being of opinion that there would be a falling off in the attendances at the scientific meetings. Such, however, has not been the case, as at the present day they are attended far better than in the past.

How all the great improvements which have gradually been effected during the past twenty years have popularised the gardens may be best realised when we consider that the admissions, which in 1902 amounted to less than 700,000, last year exceeded 1,500,000. When the new fresh-water and marine aquarium, which the council has decided to build under the Mappin Terraces, is completed, the latter figure will no doubt be exceeded.

## The Resonance Theory of Audition.

By Prof. E. H. BARTON, F.R.S.

THE resonance theory of audition continues to excite considerable interest and must be regarded as being still in the controversial stage. The very name is somewhat unfortunate and may have led some into the mistaken view that some sympathetic vibrators in the ear are postulated as capable of actual resonance or resounding like a tuning-fork set in audible vibration by another which was first sounded. Of course it should be understood, on the resonance theory, that the vibrator in question merely vibrates when a sound of nearly its own proper pitch is received by the ear, such vibration, though effecting audition by its possessor, being quite inaudible to others. Some through misunderstandings on this or other points have failed to grasp the essentials of the resonance theory of audition, and have in consequence

levelled at it criticisms which clearer knowledge on their part would have obviated. No attempt will be made here to locate in the ear those mechanisms, if any, which play the part of sympathetic vibrators, responders, or resonators. That is left to the anatomists to discover. But we may note briefly the essentials of the resonance theory, the salient facts of audition and what power the theory has of meeting the demand which those facts make upon it. In the latter we may derive help from the consideration of a simple working model which any one may set up and experiment with for himself.

*Essentials of the Resonance Theory.*—This theory postulates the existence within the ear of some set of mechanisms, each of which has its own proper rate of vibration and rate of dying away when

left to itself. Each such vibrator can accordingly be set in vigorous vibration by very feeble forces, provided they occur at or very nearly at the rate in question. These sympathetic vibrations would quickly die away when their stimulating cause ceased. Each such vibrator is supposed to have nervous connexion with the brain so that the fact and amplitude of its vibrations may be transmitted thence and duly noted.

The theory is not primarily concerned with the exact nature or details of structure of these vibrators provided only that they fulfil the foregoing conditions for mathematical theory shows that the response of one such vibrator to the forces exerted upon it by another vibration obeys the same general laws quite independently of the details and nature of the vibratory responder under consideration.

*Facts of Audition.*—For normal ears the following may be regarded as the chief facts of audition with which we are here concerned :

(i.) The range of audition is limited at the upper and lower ends, such limit varying with individuals, but about eleven octaves are usually audible.

(ii.) Before either limit of audition is reached the notes may be recognised to be very high or low, but the distinct location of pitch fails, so that only about seven octaves are musically available.

(iii.) At about the middle of the range the discrimination of pitch between near notes when sounded successively is, for a keen ear, about the twentieth of an equal-tempered semitone or  $\frac{1}{20}$ th of an octave.

(iv.) When two very near notes of almost equal intensities are sounded simultaneously, the difference of their frequencies may be recognised by any one as the number of beats per second. This may serve to discriminate a pitch-difference of the fortieth of a semitone or half that just named.

(v.) When two different notes at a considerable interval (say C and G) are sounded together, both notes can be heard and their interval estimated, they are not mistaken for a single note of intermediate pitch (E or E $\flat$ ). (This deserves special notice as being the direct opposite of colour vision for some parts of the spectrum, and will be dealt with in another article.)

(vi.) When several simple vibrations occur simultaneously, being produced in association from the same vibrating source, string or wind, the resulting character of the compound tone or note is recognised and spoken of as its quality, quality of tone, or tone simply.

(vii.) A musical shake of about ten notes per second on a note of frequency about a hundred and ten per second can be heard distinctly.

*Power of Theory to meet the Facts.*—Having briefly reviewed the chief facts of audition we may now naturally ask what power the resonance theory has to meet the demands thus made upon it. In other words, can the physicist imagine a set of vibratory responders the behaviour of which under vibratory stimuli would give results which correspond to those of human audition? In trying to arrive at a right or possible solution, obviously many variables are at our disposal. They may be stated thus :

(a) The total range of pitches of the set of responders.

(b) The musical intervals between adjacent responders.

(c) The damping (or rate of dying away) of the

vibrations natural to these responders when started and then left to themselves.

(d) The constancy or otherwise of the intervals and of the dampings throughout the range.

(e) The fineness of discrimination of relative amplitudes of vibrations of adjacent or other responders by means of the nerves attached to them.

These variables are more than are needed to make a solution possible ; they leave a choice between a variety of possibilities which may be imagined by the physicist and suggested to the anatomist for examination and rejection or acceptance. Thus, for example, the less the damping natural to a set of responders the easier is the location of pitch by them. But the presence of objectionable damping could be balanced by an enhanced fineness in the nervous discrimination of relative amplitudes of adjacent responders. A word or two of explanation may be desirable as to the relation between the damping natural to a vibratory responder and the nature of its responses to various alternating forces of nearly its own frequency. Without entering here into the niceties of the mathematical theory it may be said broadly that the best response follows only with the best tuning between the frequency natural to a responder and that of the forces acting upon it. But the actual value of this response and its falling off consequent upon mistuning both depend on the damping natural to the responder. If the damping is very slight, then the response is very vigorous for precise tuning, but for quite small mistunings the response is almost negligible. This is often summed up by saying that for slightly damped responders the resonance is *sharp*. On the other hand, for highly damped responders the response is not so good for best tuning as in the former case, but this response is only slightly impaired by moderate mistuning of the forces. In other words, for strongly damped responders the resonance is *spread*.

Bearing these facts in mind we have to make a choice among the possibilities open to us so as best to meet the facts of the case. The facts (iii.) and (v.) show that the damping must not be too large, because that would involve spread resonance instead of the sharpness needed for the actual fineness of location of pitch experienced. On the other hand, fact (vii.) shows that the damping must not be too small, as in that case the sound heard from one note of the shake would run into that of the next and give a blurred effect contrary to experience. We have thus found limits between which the damping should lie.

In view of these considerations we may submit the following suggestions. Let it be supposed that in the ear there is a set of vibratory responders which—

1. Cover a range of seven or more octaves,
2. Are about twelve to the octave in the middle of the range and have a suitable damping,
3. Are in total number about a hundred.

*Simple Model and its Behaviour.*—To test the adequacy of the arrangement just postulated let the following simple model be set up as shown in the diagram, Fig. 1.

This responsive model consists essentially of a stout cord stretched across a room between the fixed

points H and J, with a pendulum KL with heavy bob L to act as driver, and a number of light graduated responders lettered C to C'. The latter have small paper cones about 2 cm. high as bobs, with the addition of split rings of copper wire resting on them to prevent the damping being too great. The driving pendulum has a "tightener" at M to adjust its length, which must be reckoned from L up to N, since when the heavy bob L swings the bridle HKJ swings about the line HNJ. The lengths of the light responders, on the other hand, must be reckoned only up to their suspension point on the cord HK. These light responders have suspensions of thread which are passed through the cord HK and may then be cut off and the adjustment to place made so that the line of the bobs CD—C' passes through H. This is essential in order that each responder receives an equal inclination by a given displacement of the heavy bob L. In the

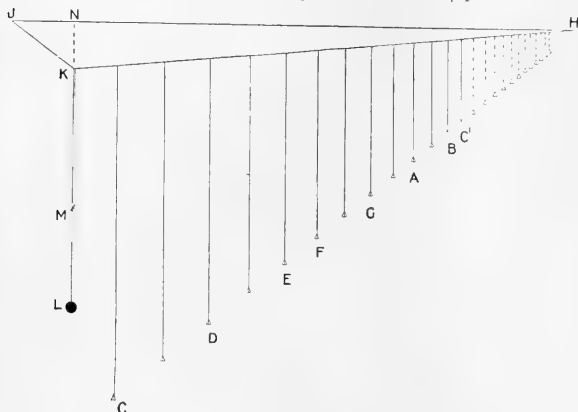

FIG. 1.

diagram just one octave of responders is shown, the number being thirteen and the lengths such as to make their relative frequencies those of the consecutive notes on the piano or organ. This allows a fineness of discrimination of pitch in agreement with experience. Of course to represent the whole set of aural mechanisms, seven or more octaves would be needed, but a single octave on the model enables one to carry out a number of interesting tests, though for some, two octaves are necessary, as shown by dotted lines in the figure. For the latter the lengths of the responders (and also the distances from H of their points of suspension) may be as follows: 57.05, 50.8, 45.25, 40.3, 35.9, 32.0, 28.5, 25.4, 22.6, 20.16, 18.0, 16.0, 14.25, 12.7, 11.3, 10.1, 9.0, 8.0, 7.13, 6.35, 5.65, 5.04, 4.49, 4.0, 3.55 cm. Any consecutive thirteen values will do for a single octave.

We may now test the behaviour of such a model and ascertain if in essential features it typifies the mechanism in the ear, although of course it is not for a moment imagined that any pendulums exist in the ear. If vibratory responders exist there they must be of an elastic nature.

If the seven octaves or more of responders were

provided we should have the musical range of seven octaves accounted for. Further, the lack of precise discrimination of pitch for very high notes and for very low notes is explained also. Thus, for any note well within the range of the responders, when the pendulum bob L is swung, thus representing by its frequency a certain note, the responders vibrate in response, the one best in tune vibrating most, the others near it, both above and below, showing a rather less response. Hence the pitch is recognised and located by this behaviour. But if the pendulum LN is made shorter than the shortest or longer than the longest responder provided, then we have the responders near the end in question responding best but no maximum response with a return to quiescence beyond it. Thus the exact pitch cannot be located, and this agrees with experience. Consider next the discrimination of pitch between notes very near in pitch, and let us ascertain what is possible when the adjacent responders differ in pitch by a semitone or one-twelfth of an octave.

It will be easily ascertained that a discrimination of pitch of about the twentieth of this semitone is possible. For by adjusting the tightener M on the suspension KL, we can make the response of two adjacent pendulums equal, and then by repeatedly lengthening the heavy or driving pendulum the response of the lower of the two light pendulums may be increased and that of the higher one decreased till the lower one just shows a maximum, the adjacent ones above and below being alike in their response. We should then have passed over the half of a semitone only and ten steps are susceptible of discrimination in this range. Without any wire rings on the paper cones the responders would not succeed in this test, but with the rings to weight the cones there is less damping, sharper resonance, and adequate discrimination.

If two octaves of responders are provided very striking experiments can be shown as to the recognition of the overtones essential to notes of a certain quality of tone. Thus, setting the pendulum NL to the pitch of a low responder, say the third from the bottom, if the pendulum swings freely we have a responsive maximum at that responder. But if the bob L is grasped in the hand and swung to and fro in the same period as before, but with a "dimple" at one end of the swing, it is really executing tone and octave, and the responders will promptly show the corresponding two resonance humps. Again, if the bob L is swung to and fro, with a "dimple" at each end, it is really executing tone and twelfth (frequencies 1 and 3), and the responders give the corresponding two resonances. Lastly, if the bob L is moved smoothly from end to end in one direction, but returns with two kinks or dimples, we have really a vibration consisting of tone, octave and twelfth (frequencies as 1, 2 and 3), and the three appropriate resonance humps are shown by the set of responders.

Thus, without overstraining or even exhausting the



possibilities of the resonance theory it seems easy by its use to account for the main facts of audition, none of which seem in conflict with the theory. This, of course, does not suffice to establish the hypothesis, as it is conceivable that some other

might be equally successful. But, pending the advent of such a rival, perhaps the disciples of Helmholtz may be pardoned for what others might style their inexplicable interest in an old and unproved theory.

### The Lesser Whitethroat's Fanfare.

(To J. S. H.)

THOUGH lyrics mingled with tattoos

Of melodrama savour,  
The Lesser Whitethroat dares to use  
Both avenues to favour.

Behind a screen  
Of leaves unseen  
He'll croon with tenderest passion,  
Then loudly reel  
A clarion peal

Of notes in fanfare fashion:

(*Sotto voce, pp.*) *Chi'ddy-choo-ee'cheo, Wee'jo-choo-ee'chey,*  
*Wee'-chiddy-wee'chey, Choo-i'ddy, Choo-ee'!*  
Then changing time,  
And reckless of rhyme:

(*Vivace, ff.*) JIP-JIP-JIP-JIP,  
JIP-JIP-JIP-JIP,  
JIP-JIP!

But can we give this Warbler praise

When art he compromises,—  
In secret hums his native lays,  
And flash-notes advertises?

Sing, Warbler, sing!

These cries you fling

Too soon all tune will smother;

And then you'll flit

A ribald Tit,

And Whitethroats lose their brother!

W. GARSTANG.

### Obituary.

W. H. HUDSON.

THE death of Mr. William Henry Hudson at his residence in London on August 18, in his eighty-first year, removes from our midst a remarkable personality, a great writer of English prose, and a keen interpreter of Nature.

Mr. Hudson's father emigrated to the Argentine in the early part of the last century and settled on the pampas, and it was there that his childhood and early life was spent. We get a vivid idea of the conditions under which he grew to manhood in the pages of "Far Away and Long Ago," a volume of autobiographical recollections which he published in 1918—the vast treeless plains, the solitary estancia with a few trees around it, the semi-savage gauchos, and above all the teeming bird life along the strand of a lonely mere.

In his early days Mr. Hudson entered into correspondence with the late Dr. P. L. Sclater and sent him collections of birds and mammals. Accounts of these first appearing in the Proceedings of the Zoological Society, formed the foundation of a joint work, "Argentine Ornithology," published in two volumes in 1888-1889, to which Mr. Hudson contributed the notes and observations on the habits of the birds, while Dr. Sclater was responsible for the technical descriptions and general arrangement. This work was recently re-issued by Mr. Hudson alone, but without the technical descriptions, under the title of "Birds of La Plata." Two other volumes, well known to lovers of good writing dealing with South American Natural History, were "The Naturalist in La Plata," 1892, and "Idle Days in Patagonia," 1893.

About this time Mr. Hudson came to England and

began a long series of works dealing with the study of Nature in England. "Birds of a Village," "Nature in Downland," "Hampshire Days," "The Land's End," and the more strictly ornithological "British Birds," "Birds and Man," and "Birds in London," followed one another in quick succession. Though always in feeble health and of a delicate constitution, he tramped over southern England from the New Forest to Penzance throughout the summer, spending the winter partly in London and partly at Penzance, where he made his second home.

Recognition of his talent came late to him. In his early days in England he was unable to earn a livelihood with his pen and he was awarded in 1901 a Civil List Pension of 150*l.* in "recognition of the originality of his writings on natural history." This he resigned in August last year on the ground that he needed it no longer. "Publishers," he told an intimate friend, "threw money at him with both hands."

A man of extremely sensitive temperament, Hudson could not endure to take the life of any animal or bird, and was an ardent supporter of the Society for the Protection of Birds, to which he devoted much of his energy during recent years. He was thus out of sympathy with any form of collecting. He had, however, a wonderful power of observation, and his sense of hearing was extremely acute. His writing is simple, lucid, and descriptive, and he never gave to his observations on bird or animal psychology that anthropomorphic tendency which so often characterises the writers of popular works on natural history subjects. Though he can never be reckoned among the ranks of scientific ornithologists, his writings will undoubtedly endure as monuments of accurate observation and of limpid, lucid, English prose.

## Current Topics and Events.

IN an address to the Rothamsted branch of the National Union of Scientific Workers, reported in the *Scientific Worker* for June, Prof. A. L. Bowley pleaded, as so many have done, for an "interpreter" to mediate between science and the laity. He suggests that "one test of greatness in works of art is that they should make a direct appeal to those whose powers of appreciation are not specialised," and, by analogy, that the greatest science should be the most easily interpreted. But what does the analogy really prove? The "art" which is appreciated without any specialisation is that of the Merry Widow waltz or Poems of Cheer; the appreciation of a Bach fugue or a Shakespeare sonnet *does* require some "specialisation"; it requires, not practice of the art, but some deliberate self-education. If the laity would (or could) educate themselves in science as they do in art, interpreters might be forthcoming who would do for science what in our generation Berenson and Mr. Roger Fry have done for painting or Sir Henry Wood and Mr. Ernest Newman for music. The difficulty now is that the wholly "unspecialised" laity demand "interpretation" in terms of concepts of which science denies the validity, just as they demand sensual prettiness in painting and catchiness of tune in music. Before interpretation can begin there must be an effort to understand; men of Prof. Bowley's eminence in other branches of learning must not pronounce *ex cathedra* that "science is not beautiful"; men must know that science is beautiful—to those who will train themselves to appreciate its beauty.

THE *Museums Journal* for July 1922 criticises the announcement of the Board of Education that in future local authorities will be charged with half the actual cost of transporting the collections sent on loan from the Victoria and Albert Museum to provincial museums and art galleries. Hitherto there has been a uniform charge of 2*l.* 10*s.* The change will make little difference to places near London, but will be prohibitive for the less wealthy distant towns. The collections of the Victoria and Albert Museum were originally intended to help museums and students throughout the country. Gradually there arose a division between the objects retained in the museum and those put into circulation; but the Circulation Department remained an important section of the museum. Now it is contended that the two are "in hopeless competition in regard to purchase of objects." This, if true, is absurd, and we agree that something should be done to co-ordinate the work of the various national museums *inter se* and with the work of the provincial museums.

WHILE the *Museums Journal* seems to be of the opinion that the national museums do not do enough for those in the provinces, Mr. Lawrence Haward, in a lecture to the Royal Society of Arts (published in the *Journal of the Royal Society of Arts* for July 28, and in the *Museums Journal* for July and August 1922), says: "If more has not been done to make the National

Collections available to the nation, as distinct from the inhabitants of London, it is largely, I think, because the provincial galleries have not always realised how ungrudgingly those in authority in the great National Galleries and Museums will impart their knowledge and render assistance in a variety of ways to their provincial colleagues out of the abundance of their own treasures." And again, he says of provincial museums: "If only they know how to use their opportunities, and are given a fair chance of putting their knowledge into practice, they can become a really vital influence in the town . . . acting as cultural centres for the whole community." Without attempting to decide whether it is the national museums or the provincial museums that are most to blame, such acquaintance as we have with the work of both has forced us to the conclusion that the provincial public does not sufficiently appreciate the advantages of its own local museums, and frequently worries the officials of metropolitan institutions with questions that would have been much more conveniently dealt with nearer home.

IN commemoration of the bi-centenary of the appointment of Bernard de Jussieu as demonstrator of botany at the Paris Jardin des Plantes, the Abbé L. Parcot in *La Nature* (July 1) gives an interesting account of his work, especially the foundation of the Botanic Garden at the Petit Trianon at Versailles. The latter was of supreme interest as the birth-place of the natural system of classification of plants. De Jussieu was commissioned in 1750 by Louis XV. to lay out a botanic garden at Petit Trianon. Sixteen years before, Linnaeus had published his artificial system of classification which was enthusiastically adopted by botanists owing to its simplicity of working, as it was based on obvious characters of the sexual organs. Linnaeus had, however, also published some "Fragmenta" of a natural system; that is, one in which plants were arranged according to the sum of relationships of all their characters. Starting with these "Fragmenta," de Jussieu developed a system according to which he arranged the plants in his new garden, and prepared a manuscript catalogue indicating the grouping of the genera in families, and also the list of species included under the genera. This catalogue was published by his nephew, Antoine Laurent de Jussieu, in 1789, twelve years after the death of Jussieu himself. The system was further elaborated by Antoine, and later by Augustin Pyrame de Candolle, and attained its modern development in the classic work of Bentham and Hooker. The famous botanical school and garden of the Trianon were dispersed after the death of Louis XV., and for a long time the site of the garden was uncertain. L'Abbé Parcot has, however, reproduced in *La Nature* some original plans in which the position of the garden is indicated, to the right of the chateau: a cedar of Lebanon and other conifers remain where they were planted by de Jussieu, and a few other of his trees which were replanted in the lawns and flower garden are still standing.

AN imposing scientific expedition set out from San Diego on July 9 last for a two months' cruise among the islands off the west coast of Lower California. According to *Science*, the chief object of the expedition is to make investigations into the present abundance and condition of the southern fur seal, the southern sea otter, and the elephant seal in the localities visited. It had been thought that these valuable animals were extinct, but recent discoveries have shown that a few still exist, and combined action of the United States and the Mexican Governments is necessary for their preservation and exploitation. Advantage will be taken of the opportunity for making surveys of the flora, fauna, and geology of the islands, which hitherto have been but little explored. The expedition has been under consideration by the California Academy of Sciences for some time past, and its realisation has been made possible by the co-operation of the Government of Mexico and a number of American institutions, including the San Diego Museum of Natural History, the Scripps Institution for Biological Research, the National Geographic Society, and the Pacific Division of the American Association for the Advancement of Science. The Mexican Government has loaned the fishery guard boat *Tecate* for the expedition and has accepted as its guests all members of the expedition sent by American institutions. Sen. Carlos Cuesta Terron, professor of herpetology and biology in the National Museum of Natural History of Mexico and a Government representative on the expedition, is director, but the scientific investigations will be in the immediate charge of Dr. G. Dallas Hanna, of the California Academy of Sciences, and A. W. Anthony, of the San Diego Museum of Natural History.

MR. ERNEST A. SMITH has resigned his position as secretary of the British Non-Ferrous Metals Research Association and accepted an appointment as research metallurgist to the Sheffield Smelting Company, Ltd.

MRS. KAPP writes to correct a statement respecting her late husband's parentage that appeared in the obituary notice in *NATURE* of August 19. She informs us that Prof. Gisbert Kapp's father was not German but a native of Trieste and the governing civil councillor of that city.

ENGINEER VICE-ADMIRAL SIR GEORGE GOODWIN, late Engineer-in-Chief of the Fleet, and Dr. James Colquhoun Irvine, vice-chancellor and principal of the University of St. Andrews, have been appointed members of the Advisory Council to the Committee of the Privy Council for Scientific and Industrial Research.

THE *Times* of August 28 announces that a special Press telegram from Prof. J. W. Gregory, of Glasgow University, reports his safe arrival at TaliFu, Yunnan, after a successful journey in Tibet. It will be remembered that Prof. Gregory and his son, Mr. C. J. Gregory, left England for Rangoon at the end of March last with the object of investigating some features in the mountain structure of north-western Yunnan and western Szechuan (see *NATURE*, January 12, 1922, vol. 109, p. 51).

A NOVEL feature of the forthcoming Swansea meeting of the Institute of Metals will be the inauguration of a series of annual public lectures on subjects of practical interest to those engaged in the non-ferrous metals industry. Dr. R. S. Hutton, director of the British Non-Ferrous Metals Research Association, is to deliver the first, which will be entitled "The Science of Human Effort (Motion Study and Vocational Training)," on September 19. Further particulars of the meeting, which will be held on September 19-22, can be obtained from the Secretary, Mr. G. Shaw Scott, 36 Victoria Street, London, S.W.1.

A NOTE on *The Pan-American Geologist*, published in *NATURE* on July 1, has brought from the office of *Economic Geology* a letter (unsigned) stating that *The American Geologist* still remains incorporated with that journal, and that the names of some geologists given as associate editors of *The Pan-American Geologist* were used without permission. If we have repeated erroneous statements we regret it; but those statements had been in our hands for some months, and were not published by us until we saw actual parts of *The Pan-American Geologist*, which appeared to confirm them.

THE Cleveland Technical Institute at Middlesbrough has issued for nearly a year a monthly Bulletin containing abstracts of the most important scientific and technical articles which have appeared in home and foreign periodicals during the month. The Bulletin is printed on one side of the page only, and each issue consists of about 60 pages. Each abstract is on the average about half a page in length, and the intention is that those of interest to the reader shall be cut out by him, pasted on cards, and placed in their proper position in a card catalogue. They are classified under the headings: chemistry and physics of iron and steel, mechanical and electrical engineering, fuel and fuel technology, shipbuilding and marine engineering, foundry practice, non-ferrous alloys, industrial chemistry, blast-furnace practice, and steel-making. A few pages are devoted occasionally to short accounts of recent home and foreign patents, and a list of recent technical publications is generally given each month. As a means of keeping those engaged in industry well up-to-date the Bulletin deserves every support.

AMONG the autumn announcements of Messrs. Chapman and Hall, Ltd., we notice the following: "Practical Applications of X-rays," by Dr. G. W. C. Kaye, in which will be described the various uses to which the rays can be put in commerce; and Vol. 2 of "Mechanical Testing," by R. G. Batson and J. H. Hyde, entitled "Testing of Apparatus, Machines, and Structures." The work will deal with the methods of testing Dynamometers, Gear Boxes, Girders, Reinforced Concrete Structures, Pumps, Springs, Ball-bearings, etc. In the "Directly-useful Technical Series," "Electrical Measuring Instruments and Supply Meters," by D. J. Bolton, will be issued.

## Research Items.

**CHILD SACRIFICE AT CARTHAGE.**—Historical evidence goes to show that the sacrifice of children to the Mother Goddess was not infrequent. Two French archaeologists, M. Pouissote and M. Lautier, engaged in exploring the ruins of ancient Carthage, have unearthed in front of an altar near a temple of Tanit three vaults containing the charred bones of new-born babies and children from two to three years of age. The archaeologists believe that to the left of the altar was a stone slab with a bronze grill, under which burnt a fierce fire, and here the naked bodies of the first-born were offered in accordance with the ancient rites which were regularly practised from the sixth or seventh centuries before the Christian era until the destruction of Carthage by the Romans. Others, however, believe that it was customary for the parents to reclaim the remains of sacrificed children, and that the bones now found, a gruesome pile 15 feet high, are the remains of sacrificed children placed by their parents under the protection of the all-powerful Tanit.

**A POLYNESIAN MUSEUM.**—The Bernice Pauahi Bishop Museum at Honolulu, Hawaii, was founded in 1889, by her husband, Charles Reed Bishop, as a memorial of Princess Pauahi, the last of the Kamehameha family of the chiefs of Hawaii. It is devoted to the study of Polynesian and kindred antiquities, ethnology, and natural history. Besides the material from Polynesia and other Pacific islands, that from Hawaii is the largest and most important. A large staff of experts is employed in research and the collection of specimens, which are of large and increasing value. The Museum has recently published a useful collection of proverbial sayings of the Tongans, compiled by Messrs. E. E. V. Collocott and J. Havea, which, in addition to its value to students of proverbs and linguists, contains a number of useful notes on the folk-lore and customs of the people.

**HEAD-HUNTING IN ASSAM.**—Mr. L. H. Hutton, the author of two important works on the Angami and Sema Nagas, contributes a paper to the August issue of *Man* on the method in which the heads of victims are decorated and divided. In addition to complete skulls adorned with mithan or buffalo horns, or with wooden imitations of these, many houses had trophies hung up in which the skull was only partly human, the taker having got only a share of the head. In such cases the rest of the head is made of wood, or the skull of an animal, such as a pig, while in another the missing half was ingeniously fabricated from two skulls of the black gibbon (*Hylobates huluk*), making the skull look as if it had three eyes. The object of the horns is said to be to prevent the dead man hearing the call of his friends searching for him, as, if his soul were to go to them, it would instigate them to revenge, whereas if it remain with the taker of the head, it lures its late relations to put themselves within reach of the possessor of the head, and lose their own to him as well. Some Ao villages used to attain the same end by stringing the skull of one of their own dogs above the skull of their enemy. The soul of the dog made such a barking whenever the strange relations of the dead man came within call of him that he never heard them imploring his soul to return.

**HUMPBACK WHALE FROM THE MIOCENE OF CALIFORNIA.**—How often does it happen that what proves to be a valuable fossil becomes irretrievably damaged before its importance is recognised. This appears

to have been the case with a specimen of Megaptera from the Miocene Diatomaceous earth of Lompoc, California. The remaining incomplete skull has been studied by R. Kellogg (Proc. U.S. Nat. Mus., vol. lxi., art. 14), who points out that the discovery of this Miocene member of the Mystacoceti gives additional force to the views of those who have advocated the great antiquity of the Cetacea, for so highly specialised a form occurring in strata of this age affords further evidence for assuming that the evolution of the Cetacea has taken a longer period than heretofore considered plausible. A careful detailed description, illustrated by plates and text figures, completes this paper on *Megaptera miocæna*, n. sp.

**PHYLOGENY OF OCHETOCERAS.**—The Ammonite genus *Ochetoceras*, belonging to the family Harpoceratidae, is confined to the Lusitanian, Kimmeridgian, and Portlandian divisions of the Upper Jurassic and was derived from the Middle Jurassic *Opepla*. The numerous species, according to Marjorie O'Connell (Bull. Amer. Mus. Nat. Hist., vol. xlvii.), are found to fall into three phyletic series: those of (1) *Ochetoceras arolicum*, (2) *O. hispidum*, and (3) *O. caniculatum*. The relations of the European species of the first series and the Mexican and Cuban of the other two are here set forth for the first time. These relationships are shown in a series of tables and the various species discussed and described. In all three series the same orthogenetic trends in development are traceable and consist in: (a) A progressive diminution in the ratio of width to height of whorl and width of whorl to diameter; (b) a progressive diminution in the coarseness of the costæ; (c) the branching of the primary costæ at their ventral ends, and finally, (d), the branching of the intercalated costæ, or striæ.

**Eocene MOLLUSCA AND FORAMINIFERA FROM NIGERIA.**—For some years past scattered information has been obtained concerning the Tertiary fossils of Nigeria, and some of the Vertebrata have been described, but there yet existed a considerable amount of unpublished material. This through the auspices of the Geological Survey of Nigeria (established in 1919) is now being collected for publication, and the Survey's third Bulletin is devoted to the Eocene Mollusca, described by R. Bullen Newton, with an appendix on the Foraminifera by E. Heron-Allen and A. Earland. It is no slight on the eminent authors of the Appendix to say that it is necessarily mainly a list of species, since the sample submitted to them was small. It is of interest, however, to note the almost complete absence of the characteristic Eocene genus *Nummulites*. The bulk of the paper is devoted to the description of the Mollusca, and great credit is due to Mr. Bullen Newton for the excellent way in which this is done. In all, seventy-three species are described and of these more than half are definitely new and worthy of better illustration than seemingly could be given them. The results of Mr. Newton's study of these Nigerian Mollusca are exceedingly interesting; for he is able to show that the fauna is of Middle Eocene or Lutetian origin, and that some of the forms are closely allied to, if not identical with, British examples from the same geological horizon; that others agree with species occurring in the Upper Mokattam Beds of Egypt; while yet others have affinities with fossils from the Middle Eocenes of Alabama. Among these last is a representative of the genus *Bulbifusus*, hitherto known only from America. Truly a strange linking together in past ages of remote parts of the

globe, still more emphasised by the recent discovery of one of the species, *Cardita* [= *Venericardia*] *planicosta*, in Peru (NATURE, April 29, 1922, p. 561).

THE ORIGIN OF IGNEOUS ROCKS RICH IN ALKALIES.—Dr. S. J. Shand ("The Nepheline Rocks of Shekunikiland," Trans. Geol. Soc., S. Africa, vol. xxiv, p. 111, 1921), discusses an occurrence of the so-called alkaline igneous rocks in and around the farm Spitzkop in the Transvaal. Following the work of N. L. Bowen, he holds that the original magma separated during cooling into a norite and a mass rich in alkalies. The latter rose towards the surface through the well-known dolomite formation, and floated up a huge mass of limestone, which has a visible area of half a square mile. By reaction with the limestone, as R. A. Daly has urged in other cases, a nepheline-syenite (foyaite) magma was produced, which becomes much more calcareous in the neighbourhood of the limestone. The author furnishes a good review of the whole question in "The Problem of the Alkaline Rocks" (Proc. Geol. Soc., S. Africa, 1922, p. xix). He defines an alkaline rock by pointing out that in common igneous rocks the alkali-metals [does he not mean their oxides?] "are combined with alumina and silica in the molecular proportion of 1 : 1 : 6 (in feldspars) or 1 : 3 : 6 (in micas). An alkaline rock, if names are to mean anything, should be one in which the alkalies are in excess of the 1 : 1 : 6 ratio, either alumina or silica or both being deficient." He then discusses the work of N. L. Bowen, who, since the publication of Shand's paper, and in association with G. W. Morey, has shown that orthoclase, at about 1200°, does not melt as a whole, but yields leucite and a glass (Am. Journ. Sci., vol. cciv, p. 1, 1922). Bowen and Morey point out that leucite may thus arise as a temporary mineral in cooling granite magmas; since it breaks up into orthoclase and nepheline, the characteristic minerals of the nepheline-syenites may arise in association through this intermediate phase.

BIRDS MARKED IN EUROPE RECOVERED IN SOUTH AFRICA.—In the August number of *British Birds* Mr. H. F. Witherby records the recovery at Jansenville, Cape Province, on January 8, 1922, of a swallow ringed as a nestling in Berkshire on August 20, 1921. Details of the five previous records of the kind are recapitulated, with a useful map, but these have already been quoted in NATURE in Dr. Thomson's recent article (March 16, vol. 109, p. 346) on the migrations of British swallows. In the same publication Mr. W. L. Sclater directs attention to a record of a common tern marked in East Prussia and recovered in Natal; another common tern marked in Sweden has been recovered in Cape Province, while there is also a remarkable record of one marked in Maine, U.S.A., and recovered in West Africa. Apart from these six swallows and two terns, the only birds which appear to have been recorded by the marking method as travelling from Europe to South Africa are white storks: there are many such records of this species, which has been largely marked in Hungary, Germany, and Denmark, and there are also several very valuable records from intermediate localities such as Central Africa. The records of European marked birds recovered in Northern Africa are less restricted as to species and include cases of the lapping, lesser black-backed gull, starling, swallow, and white stork.

ATTACK ON A MOTH BY A WASP.—Miss M. M. Buchanan sends us from Penrith a specimen of a moth which was caught while fluttering near the ground with a wasp attached to its thorax. The wasp escaped, but one from a nest a couple of yards away was *Vespa vulgaris*, Linn., and the moth was a small

Emerald moth (*Geometra vernaria*, Hübn.). Wasps, which, as is well known, are almost omnivorous, are in the habit of seizing and carrying off other insects as food for their larvae, but their chief victims belong to the order Diptera (two-winged flies). Major E. E. Austen, of the Natural History Museum, informs us that he has personally witnessed an attack by a wasp on a Drone-Fly (*Eristalis tenax*, Linn.). In this case, in spite of the fact that the victim was the bulkier insect of the two, the wasp flew away with the body of the fly in a very few moments, after first ruthlessly cutting off by means of its powerful mandibles the right wing, the head, and lastly the left wing, all of which from the wasp's point of view were evidently useless encumbrances. Since wasps are diurnal in habit, and moths, speaking generally, are the reverse, attacks by the former upon the latter can scarcely be of common occurrence, and the incident described by Miss Buchanan, if not unique, is certainly unusual.

NIGERIAN PLANTS OF ECONOMIC VALUE.—Part IV. of "The Useful Plants of Nigeria," published as Additional Series IX. of the Kew Bulletin, completes the work begun in 1908 by Mr. J. H. Holland in collating the information of plants of economic importance in Upper Guinea. The remainder of the dicotyledons and the monocotyledons are considered, and a brief note is given on the ferns and fungi. Bound with this part is an appendix containing a list of books of general interest on West Africa, a complete index to all four parts, an introduction, and a preface. Sir David Prain, in the introduction, states briefly the reasons which led to the work being undertaken and the selection of Mr. Holland, from his experience of Nigeria, as compiler. In the preface, Mr. Holland outlines the arrangement and scope of the work. Among the natural families reviewed in this part, the Euphorbiaceæ and Moraceæ provide many plants of economic importance. Under the monocotyledons, valuable information is brought together concerning, among others, the banana, pineapple, sisal hemp, yams, cocoyams, piassava, oil palm, and coconuts. The pages on the Gramineæ and the information on fodder grasses are particularly welcome at a time when stock-raising is receiving so much consideration on the Coast. The list of references to special works and monographs given at the end of each species will be found very useful, but in the illustrations cited, reference to a typical example, easily accessible, would have saved much space and rendered the work more handy. The increased price of this last part raises the cost of the whole work to 1*l.* 8*s.*, and may prevent it becoming as popular as it should be. Mr. Holland is to be congratulated on bringing this compilation to so successful a conclusion. It has entailed many years of careful research, and it fills an important gap in our reference books on West Africa.

TIDAL INVESTIGATIONS.—The third annual report of the Tidal Institute of the University of Liverpool recounts briefly a number of tidal investigations which have been begun there, but not completed, during the past year. The first two years' work established the existence of important residual fluctuations of sea-level, both periodic and irregular, which remain after all those harmonics directly accountable for by the astronomical forces have been removed. Two hypotheses which give some promise of explaining the periodic part of these residuals have been examined, but it is intended to apply further tests before publishing an account of the work. The main investigations of the year relate, however, to the irregular variations of sea-level due to meteorological causes. The method of intensive tidal analysis

adopted at the Institute isolates the unexplained residuals with considerable accuracy, and has already facilitated their reduction to law. The residuals for Newlyn thus obtained, over a period of two months, were shown by Mr. Jolly, of the Ordnance Survey, to be correlated with the local barometric pressure and its gradients in two directions at 7 A.M. on the same day. This work has been modified and extended by Dr. Doodson, who has obtained numerical formulae, depending on meteorological data, which give corrections for the predicted heights of high and low water at the Port of Liverpool, and there is a prospect of obtaining such corrections on the previous day by forecasting the pressure distribution a day ahead. The report closes with the encouraging statement that a thorough understanding of the effects of meteorological changes is now only a matter of continued effort.

**ATLANTIC HURRICANES.**—After a period of relative quietness, Atlantic hurricanes are, with the approach of autumn, likely to become a source of danger to vessels traversing the ocean. By the aid of wireless the navigator of the present day has an immense advantage over those of quite recent times, and reports from other vessels as well as from seaports on both sides of the Atlantic can now be received when at sea and charted. The *Monthly Meteorological Chart of the North Atlantic* for September, in addition to its usual information of interest to the sailor, deals with two Atlantic hurricanes experienced in September 1921. The tracks of these hurricanes appeared in the *U.S. Monthly Weather Review*, December 1921, and charts for several days which embraced the storms, as well as descriptive matter, are given in the *Monthly Weather Review*, September 1921. Detailed experiences and observations in the Meteorological Office chart will enable the seaman to see precisely how, when aloft, wireless weather reports may help him. With all the aid he may get, it does not relieve the commander from forming and using his own conclusions, and a knowledge of meteorology is more than ever of use to him. The back of the September chart gives small weather charts for each morning, showing the weather conditions over a large part of the North Atlantic from September 7 to 16. Practically during the whole of this period there were two cyclones travelling first to the north-westward and recurving later to the north-eastward, and some vessels clearly experienced both storms. A study of the various details will facilitate action being taken when in the neighbourhood of similar storms.

**MONSOONS AS RAIN MAKERS.**—In the *U.S. Geographical Review*, vol. xii., July 1922, is an article by Prof. A. McAdie on monsoon and trade winds as rain makers and desert makers. Naturally there is a large amount of originality in the article, but Prof. McAdie makes it clear that much has been taken from Dr. G. C. Simpson's lecture to the Royal Meteorological Society in March last year. The monsoon is essentially a seasonal wind, and the word is used in this sense all the world over, but those like Dr. Simpson, who with respect to India discuss it from an Indian standpoint, associate the wind with the rainy season from June to September. Prof. McAdie is more especially concerned with the monsoonal influence on the Californian coast, where the seasonal winds in the summer fail to produce rain. The heavy fogs along the Californian coast show that the water vapour is present and yet there is no rain, although the air stream must rise at least 2000 metres, because it is flowing into a region of much higher temperature and the mountains fail to become rain makers. In a midwinter month in California the mountains often rob the air stream of much of

the moisture. Instances are given of two consecutive midwinter months showing very different precipitation results. The author states that if the winds can bring rain they can also prevent rain from falling, and can in some cases cause deserts. Although warm moist air may be rising, a strong upper-air current may blow the clouds away and interrupt the process of rain making. At the coming meeting of the British Association at Hull a discussion on monsoons is to be opened by Dr. G. C. Simpson, and some further contributions to the subject may be expected.

**SURVEYING INSTRUMENTS.**—Messrs. T. Cooke and Sons, Ltd., Buckingham Works, York, have issued a revised Price List of the instruments in their Catalogue No. 256, which includes all the surveying apparatus and instruments in ordinary use among engineers and surveyors. Certain of the less common types of instruments in previous lists have disappeared, and component parts of existing types have been standardised so far as possible to cut down production costs. A great variety of well-designed theodolites are described and illustrated, ranging from the simple type of builder's transit to the "geodetic" and the "universal" micrometer instruments, giving direct readings to single seconds of arc. A full range of surveyors' levels is also listed, including the U.S. Coast and Geodetic Survey pattern, which has been specially designed for precision work and affords an exceptionally high degree of accuracy. Details are given of the various types and sizes of spirit bubbles which are manufactured by the firm and can be supplied to any degree of sensitiveness down to one second of arc per 0.1 inch of run. In addition, a series of instructive notes are given on such subjects as tests of optical properties of telescopes; the application of stadia lines to instruments; diaphragms; circles and verniers; methods of observing with micrometer theodolites. Thus the catalogue forms a useful manual of instruments for the surveyor.

**WIRELESS RECEIVING SET.**—The Metropolitan Vickers Co., Ltd., is putting on the market a compactly arranged crystal receiving set specially designed for use with the broadcasting services that are soon likely to be started in this country. The set, which is intended for a range of about 15 miles, is priced at 4l. 10s., and consists of a tuner and crystal detector in a case, with a space to hold the head telephone set when not in use; the set requires only to be connected to the aerial, for the construction of which materials are supplied with the outfit. It is not clear whether the battery is contained in the case, but with this class of apparatus one or two cells only would be necessary. The tuner is conveniently arranged for working by a handle moving over a dial, and has no rubbing contacts, being formed by two coils, the relative angular position of which can be varied. For greater changes of wave-length, alternative condensers can be cut in and out. The crystals are chosen with great care, and a spare crystal is provided with each set. The company is also placing on the market a valve set at 23l. 10s., including batteries, aerial, insulators, etc. This is designed for ranges up to 50 miles and employs two valves, one detecting and the other amplifying. The batteries are contained in a separate box, and the whole of the leads for the telephone head set and the high-tension and low-tension batteries are brought to one plug, which can easily be detached from the set before the lid is closed. This automatically throws the valves out of operation. A loud-speaking telephone can be substituted for the ordinary head set at a slight extra cost. Both these sets will pick up wave-lengths from 300 to 600 metres, and we are informed that both have been approved by the Postmaster-General.

## The Weights and Measures of India.

By C. A. SILBERRAD, President Indian Weights and Measures Committee.

A COMMITTEE was appointed by the Government of India in the autumn of 1913 "to inquire into the whole question of the feasibility of securing the use of uniform weights and measures in India." It submitted its report<sup>1</sup> in July 1914, but further consideration of the matter was delayed by the war and subsequent political developments in India, and it was only in April 1922 that, after consultation with Local Governments, the final resolution on the report was issued. This in brief approved the recommendations of the report and left it to Local Governments to give effect to them so far as and in what way each thought advisable.

Like its inhabitants, the weights and measures of India are extremely diversified; but, like them, they are susceptible of a certain amount of classification. Doubtless originally the systems which came into use at the different centres were entirely independent, but with the centralisation of administration, the unification of the coinage, and the spread of railways a certain degree of systematisation has arisen, and the weight of the tola has been assimilated to that of the rupee (180 grains), and is recognised practically everywhere as a fundamental unit, the relation of which to almost all weights in actual use is known.

The system of weights most widely known is that in force on the railways. This consists of the seer of 80 tolas (of 180 grains each) and the maund of 40 seers, with the chatak of 5 tolas. This system is used almost to the exclusion of any other in the west of the United Provinces, the Panjab, except a tract in the centre and the districts bordering on the North-west Frontier Province, the Hazara district of the latter, Sind, Baluchistan, the north of the Bombay Deccan, and the greater part of the Central Provinces. In the Central Panjab, the southern portions of the United Provinces, Chota Nagpur, and practically all Bengal and Assam this system is in use in combination with various other seers—usually known as *kachchha* (i.e. imperfect) seers, consisting of a variable but always smaller number of tolas—usually 40 to 60. In Rohilkhand (United Provinces) and the western Panjab with the trans-Indus portion of the Frontier Province the most usual system is one in which the seer contains about 100 tolas, while in Gujarat that most commonly used contains 40 tolas.

In the eastern parts of the United Provinces and the greater part of Behar proper, with adjoining portions of Chota Nagpur, the popular systems are extraordinarily variable. They are based on some number of *gandas* (sets of four) of the local pice (copper coins). These are of two kinds—Gorakhpuri and Lohiya. The Gorakhpuri pice were coined at Butwal in Nepal, and like Lohiya pice consist of shapeless dumps of copper, the weight of which was variable when they were new, and has become much more so with use. A number of *gandas* of such pice was taken to represent the seer of the place concerned. That number would naturally represent a somewhat different weight when other pice were used, so some would be added or subtracted, and that new number would start a new seer. Matters were further complicated by the adoption of the rupee in some places as unit instead of the local pice, the same numbers being used. The numbers supposed to be equivalent to a definite weight vary considerably, a fair average is 100 Lohiya pice = 92 Gorakhpuri pice = 80 tolas. In the Gorakhpur district seers of 8, 8½, 11, 12, 13,

13½, 13¾, 14, 21, 22, 24¾, 25, 27, 27¾, 28, 32, 36, and 40 *gandas* of such pice are reported, while with other seers the total number reported as in use in various parts of the district amounts to 42, not to mention several *panseris* (literally five seers) weights to which there is no corresponding seer in use. The Lohiya pice are fully as variable; 121 separate *gandas* when weighed were found to give 60 different weights varying from 531 to 675 grains. The result is extraordinary confusion.

The *kachchha* seer of 32 to 36 tolas used in the central Panjab has a somewhat similar origin, this seer being supposed to be the weight of 36 *mansuri* pice, a coin coined in the Maler-Kotla state and of varying weight, the 36 averaging 33½ tolas. Similarly in the north-west Frontier Province the Peshawari seer was supposed to be the weight of 102 Doadzashahi or Nanakshahi rupees, each of which was slightly heavier than the present rupee.

Lastly, there are the tracts where a small seer of 15 to 28 tolas is used to the more or less complete exclusion of any other seers. Thus in Bombay city the ordinarily used seer is of 28 tolas, and small seers of something near this weight are current throughout the southern Bombay Deccan, the Konkan, and west Berar.

Throughout these parts of India the table of weights is very similar. The chatak is always one-sixteenth of the seer; it is, however, known by other names—e.g. it is a *kanwa* in parts of Behar and Orissa, a *shayak* in the western Panjab, and an *anna* in Sind; while the sixteenth part of the central Panjab *kachchha* seer is termed a *sirsai*. In some tracts the chatak is divided into four parts; these are termed *kachha* in Bengal and *duko* in Sind.

The maund, though usually containing 40 seers, does not do so by any means always, the variations in this respect being by commodities as well as by localities. Thus in Cawnpore a dozen different maunds, containing from 41 to 63 seers (of 80 tolas), are in use for various kinds of merchandise, and in Bombay city seven maunds and 12 khandis. This latter is a weight supposed normally to contain 20 maunds, those in use in Bombay vary from 11 to 28 Bombay maunds (of 40 seers each of 28 tolas).

So far as they fall into this classification the Madras weights come under this head, as the standard seer for Madras contains 24 tolas and the larger seers are but little used, though the 80-tola seer is known through its use on the railways and by Government. The standard table is 3 tolas = one palam; 8 palams = one seer; 5 seers = one viss; 8 viss = one maund. But the palam is 6 tolas in Madras, varies from 3½ to 15 in Malabar, and is ¼th pound avoirdupois in Tinnevely. The viss too may sometimes be 6 seers, and maunds and khandis (usually 20 maunds) vary as greatly here as elsewhere. Certain places have other peculiar weights—e.g. the *thukku*, varying from 100 to 250 tolas, and the *tulam* from 800 to 1350. An interesting survival is the use of the Dutch pound (termed *rathal* and deemed equivalent to 42½ tolas) in Cochin. Similarly the British pound has given rise to a *rathal* of 38½ tolas, and in the parts of Arcot near Pondicherry the half-kilo to one of 42.9 tolas. The Madras weights are the most confused and complicated of all India, this being due possibly to the greater differences between the peoples composing its population, and to the fact that much of the Presidency never formed part of the Mughal Empire, and that consequently the basis of many of the weights was not the rupee but the pagoda or some

<sup>1</sup> Report of the Weights and Measures Committee, published by the Government of India. Government Central Press, Simla. Rs. 2.

other coin, so that the adoption of the rupee tola as a unit was more difficult.

The following table, showing the number of different seers reported to the Weights and Measures Committee in 1913-14 in each province, will give perhaps a clearer idea of the complexity and confusion of Indian weights than anything else:

Province.	Number of Seers equivalent to						Total.	Weights in Tolas of smallest and largest Seer.
	Less than 30 Tolas.	30-50.	50-70.	70-90.	90-110.	Above 110.		
United Provinces . . . . .	4	21	11	24	30	13	106	187-139
Bengal . . . . .	1	..	7	19	10	6	43	16-189
Madras . . . . .	12	2	..	13	2	..	29	20-105
Behar and Orissa . . . . .	1	18	12	16	8	3	58	23-132
Punjab . . . . .	..	15	..	4	8	..	27	30-105
Bombay . . . . .	15	8	1	5	..	2	23	13-130
Central Provinces . . . . .	3	2	1	2	3	..	11	21-100
Assam . . . . .	..	..	2	6	4	2	14	60-120
N.-W. Frontier Province	..	..	1	3	4	2	10	50-154½
Baluchistan . . . . .	..	..	..	1	..	..	1	50

Weights smaller than the tola are used mainly by jewellers and physicians, and the most fundamental unit for these throughout India would appear to have been originally the red and black seed of the *Abrus precatorius*, termed in Northern India the *gunchi*, and assumed to weigh one *ratti*. Other seeds and grains were also used, such as the poppy seed, the seed of the *Cesalpinia sepiaria* and grains of *juar* (the greater millet), rice, wheat, and barley. The tola used in this table frequently differs from that of 180 grains, but is now usually connected therewith by being deemed equal to a definite number of rattis more (or less) than the standard tola. A very usual table in Northern India is—8 *khaskhas* (poppy seeds) = one *chawal* (grain of unhusked rice); 2 *chawal* = one *jau* (barleycorn); 4 *jau* = one *ratti*; 8 rattis = one *masha*; and 12 *mashas* = one tola. In Bengal, Behar, and Assam the *dhan* (grain of husked rice) takes the place of the *jau*. In Bombay and the Central Provinces 2 rattis make a *val*, which is held to be represented by the seed of the *Cesalpinia sepiaria*, while in part of the Chanda district a grain of wheat serves this purpose. Throughout Behar, Bengal, Assam, and the greater part of the Central Provinces the jewellers' tola is usually 180 grains. In Northern India it is usually greater by from one to twelve rattis, the most usual values being two, three, or four rattis in excess. Occasionally, however, the gold tola is less than 180 grains. In Bombay it varies from 172 to 192 grains. In Madras jewellers' weights seem to vary almost from district to district, and the complications are innumerable. The seed of the *Abrus precatorius*, held to represent the weight *gundamani* or *guruginja*, is a frequent unit, but various obsolete coins (e.g. the fanam and the pagoda) and their fractions are in use, and the relations of these weights to the 180-grain tola usually but little known. As an example of the result of these multifarious measures it may be mentioned that silver is occasionally weighed in Madras by a table which is connected with the standard tola by the fact that 3399 of the rattis thereof are equal to 64 tolas! As a matter of fact, throughout India current silver coins are largely used as weights, though the larger jewellers frequently have well-made sets of weights representing the locally current table.

There remains Burma. The weights of this province though showing some connexion with those of Madras, are fundamentally different. The universally current unit is the *peiktha*, usually known to Europeans by its Madras name of *viss*, which has been fixed by Government as 140 tolas (3.60 lbs. avoirdupois), though as a matter of fact this "fixation" has had

but little effect outside a few of the municipalities. It varies slightly, having apparently originally been really about 142½ tolas, and was formerly held to be equivalent to 3.65 lbs. avoirdupois (or 141½ tolas). The *peiktha* is divided into 100 *kyat* or *gyat*, known to Europeans as *tikal*. This, it may be mentioned, is, so far as I know, the only truly decimal subdivision current anywhere in the Indian Empire.

For weights below the *tikal* the original table appears to have been 2 small *ywés* = one large *ywé*; 2 large *ywés* = one *pé*; 2 *pés* = one *mú*; 5 *pés* = one *mat*; 2 *mats* or 5 *mús* = one *ngá-mú* ("five-mú"); 2 *ngá-mús* = one *tikal*. Various seeds are used to represent some of these weights; thus, that of the *Abrus precatorius* is held to be equal to the small, and that of the *Adenanthera pavonina* to the large *ywé*, while the seed of the *Garcinia pedunculata* is occasionally deemed equal to 8 large *ywés*. This table was complicated by the fact that, owing to intercourse with India, the *tikal* was divided also into 16 parts, equally known as *pé*, and then four of these went to the *mat*. Further complications were introduced by the application of the same series of subdivisions to the tola of 180 grains, as fundamental unit, in place of the *tikal*, while in the Ruby Mines district the *ratti* is thus subdivided. The result, needless to say, is extreme confusion.

British (avoirdupois) weights are a good deal used in Bombay city and some of the big towns of Bombay, Berar, and the west of the Central Provinces, and in a considerable number of places in Madras, but practically only in large places and by the larger establishments. Not infrequently the nearness of the pound weight (39½ tolas) to the half of the 80 or the whole of the 40 tola seer leads to mistakes, or even to deliberate fraud. Any knowledge of the metric system is confined practically to the neighbourhood of Pondicherry.

Only the more important variations have been discussed; to give anything like a complete list would be far beyond the limits of space admissible. The Weights and Measures Committee of 1913-14 prepared a complete list showing for each district in India and Burma all weights and measures reported to them as in use. It forms a volume of some 500 pages. Enough has, however, been said to show the extreme confusion in weights that exists in many parts of India.

Apart from the use of seeds to represent weights there are few items of special interest. In Upper Burma before the annexation, weights based on the system sanctioned by the King were always made in the form of the *hentha* (known in India as the Brahmini duck). Although in many parts of India well or fairly well made metal weights are in use, often the actual weights consist of lumps of metal or stone, while smaller weights are made out of buttons, etc. Even where cast-iron weights are in use it will frequently happen that there is no indication as to the precise seer, etc., which is deemed to be represented. Thus two or more iron seers of identical appearance but different weights may be found in use in the same town, and sometimes even in the same shop.

In a few places, and these by no means the more advanced, locally made steelyards are used; thus in Cuttack the *bisa* is a steelyard with movable fulcrum used to weigh articles up to 4 or 5 pounds. Similar steelyards, called *tu* or *talachoni*, are in use in several districts in the Brahmaputra valley. In Burma, steelyards with fixed fulcrum (known as *le-dan* or *taing-tzu*) are regularly used by the Chinese, but



looked askance at by the Burmans, who sometimes find themselves outwitted by the Chinaman when it is used. This instrument, frequently well made of bone or ivory, has one movable weight and two or three points of support, with scales marked on the rod corresponding to each point of support.

*Measures of Length.*—As almost throughout the world the cubit, or distance from the elbow to the tip of the middle-finger, was the original fundamental unit. This is subdivided into spans, fist-breadths, and digits, and also into sixteenths. A very usual table in Northern India is: 3 jau (barleycorns) = one angul (digit); 3 angul = one girha; 4 angul = one mushti (fist-breadth); 4 girha or 3 mushti = one balisht (span); 2 balisht = one hath (cubit); 2 hath = one gaz (yard).

The names of the various measures of length naturally vary in different parts of the country; thus the yard is a *val*, *var*, or *war* in Bombay and the Central Provinces, and a *gaik* in Burma; the cubit, known as *hath* throughout Northern India, is a *mura* or *mulam* in parts of Madras and a *taung* in Burma. The *girha* is a *visam* in Madras, but corresponds to no measure in Burma. The *balisht* of Northern India is the *bighat* of Bengal, the *jana* of parts of Madras, and the *htwa* of Burma; but the general table is very similar throughout the whole country. The *gaz* (*gaj*, *var*, or *gaik*) varies considerably from place to place, and for different articles, and altogether the number of variants is great; the great majority, however, are within three inches of the British yard, but there are yards in use as long as 48 in. and as short as 19 in., but such are exceptional. To a greater or less extent all are being assimilated to the British yard of 36 in., and in fact many are known by their length in sixteenths (*girha*) of that measure. The foot and inch are but little known, the yard being almost always subdivided, for practical purposes, into 16 *girha*.

The most important of other yards are:

(i.) That based on the *muruwan* or *morni* (crooked) *hath* of approximately 24 in. This cubit was arrived at by measuring from the elbow round the tip of the outstretched middle-finger and back to the knuckle; it gives rise to a yard of 40 in. to 48 in., and the British yard is deemed equal to  $1\frac{1}{2}$  *morni hath*. It is in use in several districts of the Panjab near the Indus and the adjacent parts of the Frontier Province. It is divided into sixteenths (known as *sharak* or *tasu*) and also into twentieths, which are called *girha*.

(ii.) The Peshawari yard of 38 in. to  $38\frac{1}{2}$  in., of which the British yard is deemed to be  $1\frac{1}{5}$  *girhas* (i.e.  $\frac{1}{5}$ ths). It is used throughout most of the Frontier Province.

(iii.) The *Imarati* or *M'vari gaz* (masons' or carpenters' yard). It is still used fairly widely in the north-western part of the United Provinces and the adjacent parts of the Panjab. Its usual length is 33 in., and it varies from  $32\frac{1}{2}$  in. to 34 in. It forms part of a special table used in the building and carpentry trades. This is: 4 *pan* (or 2 *sole*) = one *sut*; 4 *sut* = one *pan*; 4 *pan* = 1 *tasu*; 24 *tasu* = one *imarati gaz*. This table is however sometimes applied to the British yard, giving rise to a *tasu* of exactly  $1\frac{1}{2}$  in. This yard is probably identical with the *tachumulan* of the southern districts of Madras, which is 33 in. in length and used by carpenters and masons only. In the South Arcot district there is also a special "architectural inch" of  $1\frac{1}{2}$  in. British, 24 of which make the "architectural yard." In Bombay city yards of 32 and 24 *tasu* are occasionally used for measuring cloth, this *tasu* is  $1\frac{1}{2}$  in. British measure. Beyond the similarity of names of the subdivisions there would appear to be no connection.

(iv.) The *Ilahi* or *Akhari gaz*, originated by Akbar to represent one pace for purposes of land measure-

ment, and at first  $33\frac{1}{2}$  in. in length, but now varying from  $31\frac{1}{2}$  in. to 40 in. It is over much of Northern India the basis of many indigenous systems of land measurement.

On the Malabar coast the yard is to some extent replaced by the *kole*, a measure of similar length, which consists of 24, or in places of  $26\frac{1}{2}$ , *angulams* (or *vivals*), which appear to be the length instead of the breadth of a finger joint, inasmuch as one *angulam* is held exactly to equal the diameter of a rupee or  $1\frac{1}{8}$  in.

Apart from the measures used for measuring land and distance there are practically no measures of any importance larger than the yard. Those for land measurement are closely connected with measures of area and will be considered therewith. Measurements of distance are usually vague. The normal indigenous unit is the *kos* (or in Madras, the *kvos*). Though supposed to be 4000 cubits it really has little, if any, connexion with that unit and varies from  $1\frac{1}{2}$  to 3 miles. The corresponding unit in Burma is the *daing* or *taing*, supposed to contain 7000 cubits, but in reality equally vague. With the construction of roads and railways and the indication of miles and furlongs thereupon, these measures are now almost universally known and used. A somewhat unfortunate complication has, however, been introduced into the Panjab by the invention of a Canal "mile" of 5000 feet divided into five equal parts, each of which (from the shape of the "3th-milestone" or *burji*) is termed a *burji*. Somewhat interesting is the introduction of new measures of length by reason of the way in which land is subdivided in the Canal colonies into *marabbas* (squares) and *killas* of 1100 ft. and 220 ft. square respectively. The lengths of the sides of these square areas are becoming known as measures of length under the names of the areas.

Most frequently however distances are referred to by the average villager as "the length of a field," "a gunshot," "the distance to which a man's voice will carry," etc.

*Measures of Area.*—There can be little doubt that the first measures of area depended on the amount of work involved in cultivating the area concerned, or the amount of seed required to sow, or produced by it. Thus the *bigha*, the most widespread unit of area, is said to have originally represented the area a pair of bullocks could plough in a day. Other units are defined as the area a pair of animals could maintain under cultivation throughout a year, or that they can harrow or sow in a day, or that a man can weed in a day. Many units are based on the area sown with some stated quantity of seed; in rice-growing areas by the number of paddy plants required for planting it, or as the area which a man (or sometimes a woman) can plant in a day, and so on. Another measure used in some parts is the area which can be guarded from the depredations of wild animals by one watchman on a raised platform. In Baluchistan a common measure of land is the area which can be irrigated in 24 hours.

These methods of estimating areas are still widely used by the cultivators themselves in the less thickly populated areas, such as most of the Central Provinces, Burma and Chota Nagpur, and parts of Bombay, Madras and Assam and the Himalayan tracts.

In the more densely populated parts of the country, where the value of the land is greater, a more definite method has been evolved. This throughout almost the whole of both India and Burma seems to have been based on a square each side of which is a certain number of paces, but which is now always expressed in terms of cubits. The length of this unit is extremely variable, but it would appear that in selecting a length the simplest that could be expressed conveniently in both cubits and paces was originally taken. Thus many of these units are near to 5

cubits, which, taking the cubit at 18 in., is equal to three paces of 33 in. each. This unit length has many names: in the United Provinces it is termed a *latta* or *gatha*, and the standard (so far as there was one) was three *Akbari gaz* (of 33½ in. each). The standard most often recognised by Government, however, is of 99 in., so that 20 equal a chain of 55 yards. In the Panjab, the Frontier Province, and Sind the corresponding unit is the *karam*, the most important one being 66 in. in length. In Belar and Orissa it is known as the *bais*, *lagga*, *padika*, or *nal*, and usually varies between 6 ft. and 12 ft. In Bengal it is a *dhan*, *danda*, *nal*, or *katha*. In Assam a *nal*, *tar*, or *bes*. In Bombay proper a *kathi*, and in Sind a *kano*; in Madras a *nolo* (Ganjam) or *badda* (Nellore), and in Burma a *ta* (=seven cubits or 10½ ft.). The actual area arrived at by this method is, however, most variable, and though the unit length seems to have originally been about three paces it may, as a matter of fact, be apparently anything from one to five. The more valuable the land and the more powerful the landowner the smaller is the *laggi*. A not infrequent method of raising rents was to shorten the length of the *laggi*, the "rent per bigah" remaining nominally the same for the smaller resultant bigah. Many riots have been caused by differences of opinion between landlord and tenant as to the correct length of the *laggi*. The square *laggi* has many names: in the United Provinces it is usually a *biswansi*; in the Panjab a *sirsahi*, in Behar a *dhur*, in Bombay a *kathi*, Assam a *rekh*, Burma a *palagwet*, and so on. Though it is almost always the four-hundredth part of the bigah (or corresponding unit), the intermediate subdivisions vary. The most general intervening unit is one consisting of 20 square *laggis*, known most widely as a *biswā* or *katha* ("cotta"). But in Orissa 16 of the smallest units make a *guntha*, and 25 *gunthas* go to the *man* (which corresponds to the bigah elsewhere). In the Panjab, where the square *karam* is known as the *sirsahi*, 9 of them go to the *marla*, 20 *marlas* equal one *kanal*, and 4 *kanals* one bigah. Here two bigahs make a *ghumnaon*, which has been standardised as one acre. This table holds over the western Panjab, Sind, and the Frontier Province. In Burma there are two large units—the *pēgadi* (or "public" *pē*) containing 625 square *ta* (or *palagwet*), and the min-*pē* of 35 *ta* 2½ *taung* square or 1250 *taung* *palagwet*, treated for practical purposes as exactly equal to two *pēgadi*.

In eastern Bengal the unit length is often used somewhat differently, the unit area being sometimes rectangular. Thus in Dacca and Maimansingh a common unit is the *kāni*, a variable rectangle, but most frequently one the sides of which are 12 and 10 *nal*. The *pakhī*, another frequently used unit, appears to be practically only another name for the *kāni*.

Though the system is so similar throughout the country it has not resulted in any uniformity; in fact, the bigah and connected measures are almost as indefinite as the older measures previously mentioned. Thus in the United Provinces no less than 58 bigahs, varying from ⅔<sup>th</sup> to one acre, are reported. In Champaran district (Behar and Orissa) the *laggi* varies from 10 ft. 10½ in. to 17 ft. 5½ in. In Dacca the Settlement Officer had to prepare more than 100 conversion tables to reduce the local measures of area to the acre. In much of Madras the indigenous systems appear to have had other origins; thus in Madras city the *caunie* of 1·32 acres is still used—this is equal to 20 *manai* or "grounds," the *manai* having originally been defined as the area sufficient for a small Indian house. Elsewhere the *govvu*, a measure based on the area a pair of bullocks can plough, is used; it is about 3½ to 4 acres.

There are numerous other units of area in use in

various parts of the country, and the variations of those bearing the same name are almost innumerable, but there would seem to be little purpose in giving further details.

When precision is necessary in dealing with areas which are of such vital importance to rent law and the land revenue, two methods have been adopted. Either the bigah has been standardised over a certain area or else the British acre (divided either into roods and poles, or more usually into one-hundredths) has been used. The number of different "standardised" bigahs actually adopted in the Settlement records is very great; thus in the Gorakhpur district of the United Provinces no less than nine were used. In many parts of the country the acre and its hundredth parts (generally termed "decimals," or in Burma "dathama") are becoming well known. In the Panjab Canal colonies two new units have been introduced—the *hillā* of 220 ft. square and the *marabba* (square) of 1100 ft. square, equal to 25 *hillā*, being respectively equivalent to 10 and 250 acres. In short, for all purposes where exactness is required either the acre and its subdivisions or some standardised indigenous measure is now used.

*Measures of Capacity.*—Contrary to what is sometimes alleged, measures of capacity for grain and such like articles are very widely used throughout India, the only tracts where they are practically non-existent being the greater part of the United Provinces (excluding the extreme east and south-west), most of Behar proper, and the eastern Panjab. It is true that in much of the rest of India they are mainly used in rural areas and the smaller towns and for retail and local transactions, but even so their use is widespread and certainly affects the great bulk of the people. In Burma, and to a less extent in Madras, they are of universal importance, forming the basis of large transactions. For some reason, or possibly by pure coincidence, their use is more widespread in the rice-growing areas, though by no means excluded from the rest of the country.

The unit measure of the series in use is usually defined as a measure containing a certain number of the chief current local unit of weight of the predominant grain. Sometimes a definite weight of a mixture of several (8 or 9) kinds of grain was used to fix the size. A picturesque variant to this rule occurs in the Khasia and Jaintia hills (the inhabitants of which were head hunters), where the size of the standard measure was fixed as being convenient to hold a man's head. Measures are generally used "heaped," rarely (though occasionally) "struck." As there is no uniformity in the cross-section of measures supposed to contain equal quantities this increases the variations. The measures themselves are made sometimes of wicker-work, at others of wood or metal, and may be cylindrical, rectangular, prismatic, hemispherical, or more or less globular—i.e. in the shape of a sphere with considerably less than the upper hemisphere removed. The wicker measures especially are liable to increase in size with age. Save in Burma, Madras, and a few of the larger municipalities in the Central Provinces and Berar, no attempt has ever been made to standardise them, and there has never been anything corresponding to the unifying influence of the railway seer to assimilate the measures of different places.

The chief measure of a place is generally one containing from one to five local seers of some grain, and there are various multiples and submultiples of this, the larger ones being merely measures of account. It has already been seen how numerous are the local units of weight—the reasons just given make those of capacity even more variable. The units themselves, and the names and mutual relations of their multiples

and submultiples, vary from district to district, and, indeed, are very far from being uniform throughout a district. As their use is largely confined to local transactions this variation is of less importance, for the normal customers of each market are fully aware of the measures in use there. It would be of little interest to give the innumerable names of these measures; one example of their variability will suffice. The *gauri* is a widely used measure in Orissa; the Balasore district reports the use of 18 different *gauris*, said to contain anything from 1 to over 8 seers of paddy. In Cuttack its limits are somewhat closer— $1\frac{1}{4}$  to 7 seers—while in Puri they are said to be from 2 to 8, and 9 different *gauris* are reported as in use. The actual measure is made of wicker.

The standardised measures of Madras and Burma call for more detailed comment. In Madras there are two, known respectively as the Madras type measure or *padu* and the Madras type seer; they are defined as holding respectively 120 and 80 tolas of second sort rice when "struck" or 132 and 88 when "heaped." Of water they contain 62.5 and 41.7 oz. One or other is used throughout a considerable portion of the Madras Presidency, but by no means to the exclusion of numerous other measures which may or may not bear a definite relationship to them.

It is, however, in Burma that capacity measures are of greatest importance, as it is by the *tin* or "basket" that rice is almost universally bought and sold wholesale, and by its submultiple measures retail. The table of measures most frequently used is: 2 lamè = 1 zalè; 2 zalè = 1 hkwet; 2 hkwet = 1 pyi or byi (or with the initial particle ta—*ta-byi*, whence "tubby"); 2 pyi = 1 sayat; 2 sayat = 1 seik; 2 seik = 1 hkwe; and 2 hkwe = 1 tin or basket. It is an interesting comment on the desire for a standard measure that the tin of "Milkmaid" brand condensed milk has become universally recognised as representing one lamè; the Nestlé's tin as one zalè, and the tin containing preserved liches as  $3\frac{1}{2}$  lamè. In origin the lamè is said to have been two handfuls, and the basket to have come into existence as being the amount of unhusked rice a man could conveniently carry at one time. The Burmese Government appears to have made some attempt at standardising it, and the British Government has more or less recognised as the standard basket one containing 9 gallons, other baskets being defined in Government reports in terms thereof. The baskets in ordinary use throughout the country vary a good deal, being usually somewhat smaller than 9 gallons. Most, however, contain between 8 and 9 gallons. The basket used by the rice-millers of Rangoon, Bassein, and Moulmein is as a rule a cylindrical wooden vessel,  $24\frac{1}{2}$  in. or 25 in. in height and  $14\frac{1}{2}$  in. or 15 in. in diameter. One of these measures is taken to measure a consignment of paddy, and every now and then a basket is weighed—usually 5 or 6 per 10,000. The

price is fixed at so much per 100 baskets of 46 lb., with the proviso that  $2\frac{1}{2}$  per cent. more be paid for every pound the average basket weighs in excess of 46, while for every pound it weighs less 2 per cent. is deducted. For other produce for export, baskets containing definite weights are used, and trade in them is really by weight. But rural trade is almost entirely by measure.

There are practically no true liquid measures anywhere; occasionally one of the dry measures will be used, but the usual way of selling liquids is by weight, a measure containing a definite weight of the specific liquid for which it is used being frequently used for convenience.

We thus find that throughout the country, with the exception of Burma and to a less extent of Madras (here only as regards weights below the tola), the tola of 180 grains or the weight of the rupee is a universally recognised unit, and to an almost equal extent the "railway" seer of 80 such tolas is at least known and over a large extent of the country actually used. The identity of the weight of this tola and of the rupee is a most important point to remember, as it makes it almost compulsory to change the weight of that coin if any system not based on this tola be introduced. This is a proceeding very liable to be viewed with great suspicion by the less educated portion of the community. For a measure of length the British yard is almost universally known and very widely used. As a measure of area the acre is fast becoming the only really definite one. Measures of capacity are various, but dependent on measures of weight.

Accordingly the majority of the Weights and Measures Committee recommended the adoption of the "railway" seer of 80 tolas (each of 180 grains), the British yard and the acre as fundamental units, and suggested the standardisation of suitable measures of capacity at the nearest suitable multiple of the bulk of  $1\frac{1}{4}$  seers of water, this being approximately equivalent to the bulk of a seer of wheat. This conclusion, negating any approximation to a decimal system, was certainly viewed with regret by myself, but the binary system and the rupee-tola unit are so firmly rooted in the country that it seemed inadvisable to attempt to change a method which was at least equally good for the ordinary transactions of everyday life for one the advantages of which are apparent mainly in foreign trade. The fact that practically no progress towards adopting the metric system in England has been made (*vide* NATURE, vol. 110, p. 29) is of considerable interest in this connexion, for when such is the case in a highly educated and intensely commercial country, where the proportion of foreign trade is probably higher than anywhere in the world, would it have been justifiable to recommend the compulsory adoption of the metric—or, in fact, of any decimal—system for India?

### School Instruction in Botany.<sup>1</sup>

IT is, we believe, a misfortune that so large a proportion of teachers of botany in schools know little practically of the cultivation of plants. It is, indeed, not unusual for simple laboratory experiments involving the use of growing seedlings and plants to come to an untimely end owing to lack of precautions which would be observed by every practical gardener. The uncertainty of success of even simple experiments in such unskilled hands is no doubt in part responsible for the fact that school botany is still so largely concerned with

taxonomy—which only the trained botanist can appreciate fully—and so little with those fundamental aspects of plant biology which should be of interest to all.

A general understanding of the significance of green plants in relation to the food problem, of the conditions controlling the growing of crops, and of the differences between such "artificial" vegetation and the natural vegetation of the countryside, and similar matters of fundamental importance, should be as much a part of general educational equipment as is the knowledge that the earth revolves round the sun, or the ability to use decimal notation.

<sup>1</sup> The Botany Gardens of the James Allen's Girls' School, Dulwich. Board of Education. Educational Pamphlet No. 41. Price 2s.

Those who desire to see biology take its proper place in general education, as also others more directly interested in the teaching of botany in schools, owe a debt of gratitude to Dr. Lilian J. Clarke of the James Allen's Girls' School, Dulwich, for a practical demonstration of how much can be done within the rather narrow limitations of a school curriculum to make botany a "live" subject, and also for the creation of a school botany garden in many respects unique both in design and in the manner in which it is utilised in the teaching work.

In a pamphlet before us, the publication of which has been greatly delayed by post-war conditions, Dr. Clarke gives a stimulating account of the history and organisation of the school botany gardens and the teaching work associated with them. We have no doubt that this report of an interesting experiment in science teaching will serve the purpose intended by the Board and be helpful to other schools which give special attention to the teaching of botany. To quote Dr. Clarke: "Our main object in developing the gardens has been to make the teaching of botany thoroughly practical by closely associating indoor with outdoor work. . . . The gardens have been of great assistance in carrying out the method of studying botany by direct observation and experiment: they are, in fact, outdoor laboratories."

Attention may be directed to two features of special interest in these botany gardens. One is the provision of vegetable plots in sole charge of the pupils themselves. Certain obvious difficulties must be overcome in order to make possible the inclusion of garden work as part of an ordinary school routine, and it is proof of able administration on the part of the science staff, and willing work and co-operation on the part of the girls themselves, that these plots showed a working profit during the period 1912-15. Used in this way, garden work stimulates interest in plant life and affords a reasonable basis for lessons in photosynthesis and the essential features of plant physiology.

A more unusual feature in the gardens, and one of great educational value, has been the construction of a number of special areas, each designed to provide the conditions requisite for a characteristic type of vegetation. Among these are fresh-water and salt-water marshes, a pond 34 ft. by 23 ft., a pebble beach, a peat bog, and soil-conditions favourable for the growth of chalk-loving and heath plants, as well as the successful reproduction of natural vegetation units such as an oak wood. No better introduction to the study of plant ecology can be imagined than these attempts to reproduce the essential conditions of special habitats with the subsequent collection, naming, planting, and care of the appropriate plant species.

The value of science teaching in schools would be greatly enhanced were more attention given to linking up different groups of scientific facts and to bringing them into touch with other subjects in the school curriculum and with the facts of ordinary life. Botany teaching as described in this report appears to offer an opportunity of doing this. For example, it is not difficult to link up the recognition of vegetation units such as those referred to above with the teaching of geography and history.

No mention is made in the report of the utilisation of the botany gardens for the observation of animal life, although it is clear that development is possible along these lines also. The phenomena of metamorphosis in frogs and butterflies, and the inter-relations of plant and animal life as shown by the association of certain caterpillars with specific food plants may be cited as examples, as well as the opportunity afforded for observations on the ecology of animals.

## University and Educational Intelligence.

DR. KENNETH FISHER, senior science master at Eton College, and formerly assistant master at Clifton College, has been appointed headmaster of Oundle School, in succession to the late Mr. F. W. Sanderson.

THE Council of the City and Guilds of London Institute in their report for 1921 reviews the history of this body's work from its inception in 1876. The report shows that the aggregate amount of the contributions by the City companies to the Institute's funds exceeds one million pounds. Of the several undertakings maintained wholly or in part by the Institute, the most important is the City and Guilds (Engineering) College, now constituting the engineering section of the Imperial College of Science and Technology. Of the degrees in engineering conferred by the University of London in the past twenty years, nearly half, of honours degrees more than half, were won by students of this college. The total number of students in 1920-21 was 609, of whom nearly half were taking electrical engineering. The Finsbury Technical College, which it was proposed to close last year owing to financial difficulties, has now been placed under a delegacy as a grant-aided institution subject to the regulations of the London County Council. Technological examinations conducted by the Institute were in 1921 held in 67 subjects in 316 centres, including many in India and other parts of the Empire overseas. The number of entries was nearly eight thousand.

A PROJECT for an international congress of all universities, both state and independent, of all countries, is to be elaborated by a sub-commission of the commission on intellectual co-operation set up by the League of Nations, consisting of Profs. Gilbert Murray and de Reynolds (Berne); A. de Castro, director of the faculty of medicine in the University of Rio de Janeiro; M. J. Destrée, ex-minister of sciences and arts of Belgium; and Dr. R. A. Millikan, director of the Norman Bridge laboratory of physics at the technological institute of California. This sub-commission will begin by examining, with due regard to the sovereign right of nations to legislate in matters of education and to university autonomy, the questions of exchange of professors and of students, equivalence of university studies and diplomas, the institution of international bursaries and vacation courses, and a central bureau of university information. In making these proposals the council of the League appears to have overlooked those two very efficient existing organs, the Universities Bureau of the British Empire and the American Institute of International Education, which were established by the universities themselves and are actively engaged in furthering these very objects. Another sub-committee, consisting of Madame Curie and M. Destrée and a certain number of specialists to be co-opted by them, is to study the organisation of international bibliography and the question of establishing international libraries on the basis of a convention entitling them to receive copies of all published works.

AT the fifth annual meeting of the American Council on Education reports were presented showing that under the able direction of Dr. S. P. Capen this body has accomplished much useful work and has in hand enterprises of far-reaching importance in connexion with questions of educational policy. It has played a leading part in the recent development of Franco-

American educational relations, both through its management of exchanges of scholarships and fellowships, and through collaborating with the French Ministry of Public Instruction in working out equivalencies of French and American academic records. At present 50 scholarships are offered through the Council by American universities and colleges to French students, while 40 are offered by French universities and lycées to Americans. As regards the establishment of what the French call "équivalences de scolarité," the Council's standing committee on international educational relations prepared a report (published last January) which has been accepted by the Conseil Supérieur de l'Instruction Publique as the basis for the admission of American students to candidacy for the State doctorates. The council has also a standing committee on College Standards which is engaged in devising means for effecting a general unification of procedure on the part of the several national and sectional accrediting bodies, and it has formulated already a list of basic requirements for admission to a list of accredited colleges. Another standing committee is busy with the question of tariffs on educational supplies; another is about to present a first instalment of its report on educational finance; another is investigating how the established principles of "academic freedom" may best be safeguarded and their general application be promoted in the face of threatened restrictions by legislation of the freedom of teaching and investigation; while another is to undertake a registration in the form of a directory, of college and university teaching personnel, to include at the outset at least 25,000 names.

THE programme of lectures and classes for teachers during the session 1922-23, organised by the London County Council, has recently been issued. Teachers from outside the London area are admitted to the lectures on payment of a small additional fee. The handbook is drawn up on similar lines to those of previous years, the lectures being divided into groups according to subject. Among the science lectures there are several interesting courses, among which are the following: Prof. C. Spearman and the Rev. F. Aveling, ten lectures on the experimental investigation of children; Mr. Cyril Burt, three courses of lectures on psychology and education; Prof. O. W. Richardson, ten lectures on modern views of matter and radiation; Prof. F. E. Fritch, five lectures on the vegetation of the London area; Prof. A. Smithells, one lecture on the atom; Sir William Bragg, five lectures on the constitution of matter; Dr. R. S. Clay, ten lectures on science in elementary schools; Mr. A. L. Leach, eight lectures on the geology and geography of the London district; Prof. J. Arthur Thomson, three lectures on the progress of evolution; and Prof. T. P. Nunn, six lectures on Einstein's theory of relativity and its educational bearings. In addition to these courses, there will be four special lectures—on teaching children astronomy, by Sir Frank W. Dyson; on the significance of crystal analysis, by Sir William Bragg; on the relation between the health and character of the school child, by Prof. Karl Pearson; and on the drama of animal life, by Prof. J. Arthur Thomson. The value of these special lectures by recognised authorities on their own subjects can scarcely be over-emphasised. Courses are also being organised in geography and in the teaching of arithmetic and mathematics. Copies of the handbook of the lectures, with application forms, can be obtained from the Education Officer at the County Hall, Westminster Bridge, S.E.1.

## Calendar of Industrial Pioneers.

**September 3, 1854. Henry Fourdrinier died.**—Born in Lombard Street, London, in 1766, Fourdrinier, with his brother Sealy, succeeded to his father's business of paper-making, and at the beginning of last century endeavoured to introduce the continuous paper-making machine invented in 1799 by the Frenchman, Louis Robert. He spent some 60,000*l.* improving and making new machinery, but ultimately became bankrupt. The subsequent success of the paper-making machine was largely due to Bryan Donkin, but Fourdrinier's pioneering work was acknowledged in 1840 by a Parliamentary grant to him of 7000*l.*

**September 3, 1874. Sir John Rennie died.**—The first British civil engineer since the days of Sir Hugh Myddleton (1560-1631) to receive the honour of knighthood, Rennie was trained under his father, the builder of Waterloo Bridge, and was responsible for the building of London Bridge and the completion of the Plymouth Breakwater. He was engineer to the Admiralty, carried out many important harbour works, and in 1845-1848 was president of the Institution of Civil Engineers.

**September 3, 1895. Ralph Hart Tweddell died.**—One of the pioneers in the application of hydraulic pressure to machine tools, Tweddell brought out his hydraulic rivetting machine in 1866. His methods reduced the cost of rivetting to one-seventh that of hand work. Used first by Armstrong at Newcastle in 1871, Tweddell's hydraulic machines were extensively adopted three years later in the French dockyard at Toulon.

**September 5, 1885. Walter Bentley Woodbury died.**—Originally an engineer, Woodbury spent some years in Australia, Java, and Batavia, and became known for his successful work with the collodion process in photography. Returning to England in 1863, he invented the Woodbury-type process and patented many improvements in connexion with photography.

**September 6, 1842. Jean Baptiste Van Mons died.**—The founder of the *Journal de chimie et de physique*, and a prolific writer, Van Mons at a time when the nations of Europe were at enmity, performed a valuable service by propagating abroad a knowledge of the discoveries of Lavoisier, Volta, Vauquelin, Chenevix and others. He was born in Brussels in 1765, became a pharmacist, and for twenty years was professor of chemistry and agriculture in the University of Louvain.

**September 7, 1870. Cowper Phipps Coles died.**—Flag-lieutenant to Admiral Lyons during the Crimea War, and in 1855 captain of the paddle sloop *Stromboli*, Coles first became known for his construction of a gun raft. Taking up the study of naval architecture he carried out experiments on mounting guns in cupolas, and he was afterwards responsible for the design of the ill-fated turret vessel H.M.S. *Captain* which capsized off Cape Finisterre on the night of September 7, 1870, Coles being on board at the time.

**September 8, 1761. Bernard Forest de Belidor died.**—Known principally for his writings on hydraulics, Belidor as a French military engineer made many experiments on the explosive power of gunpowder, became inspector of artillery and held a post in the arsenal at Paris. His "Architecture Hydraulique," long regarded as a standard work, was first published in 1753, while Navier published a new edition with notes in 1819.

E. C. S.

## Societies and Academies.

## PARIS.

**Academy of Sciences, August 7.**—M. G. Bigourdan in the chair.—B. Baillaud: A new transit instrument recently installed at the Paris Observatory.—S. Winogradsky: The supposed transformation of the nitrifying ferment into a saprophytic species. A criticism of the views of M. Beijerinck on the nitrifying organism.—M. Abramesco: Developments in series with two complex variables following the inverse of given polynomials.—D. Yovanovitch: The chemical properties of mesothorium-2. Radioactive barium chloride is precipitated by hydrochloric acid: the precipitate contains mesothorium-1, thorium-X, and radium. The mesothorium-2 is precipitated as hydrate, and freed from thorium B and C by treatment with sulphuretted hydrogen after adding a little lead and bismuth. Its chemical properties resemble those of lanthanum.—J. Orce! : The chemical composition of aerinite.—J. Barthoux: Minerals of the Oudjda region (Morocco). The following minerals have been found in a lead mine near Oudjda: galena, vanadinite, pyromorphite, wulfenite, cerussite, dolomite, calcite, and aragonite: details of the crystal forms are given.—Aimé Azam: The constitution and origin of the sediment of the plain of Caen called *rougeaubs* and *faucels*.—J. Voicu: The influence of humus on the sensibility of *Azotobacter Chroococcum* towards boron. In a culture medium without humus the effect of boron on the nitrogen assimilated is insignificant, but if humus is added to the culture the toxic action of boron is marked, and the amount of nitrogen fixed is reduced.—René Maire and E. Chemin: A new marine pyrenomycete.—F. Granel: The structure and development of the pseudobranchia of the teleosteans.—Paul Portier and Marcel Duval: The variation of the osmotic pressure of the blood of the eel as a function of modifications of the salinity of the external medium. The osmotic pressure of the blood serum of the eel living in fresh water is much higher than in the carp; when the salt in the water is changed from 0 to 39 parts per 1000, with corresponding change in the freezing-point from  $-0^{\circ}.02$  to  $-2^{\circ}.22$ , the freezing-point of the serum changes only from  $-0^{\circ}.63$  to  $-0^{\circ}.83$ , and the fish is not prejudicially affected. In salt solutions of higher concentration than sea water the eel dies.—Mlle. T. Duboc: The action of tribromoxylenol on tubercle bacilli.—A. Trillat: The influence of humidity and vesicular state on the diffusion in air of drops containing micro-organisms. From 93 per cent. to 99.5 per cent. of the liquid dust produced by an ordinary pulveriser fall within a few metres of the point of origin. But of the remainder, some drops are so small that they remain in suspension, especially if the air is nearly saturated with moisture, and may travel considerable distances. That micro-organisms may be carried in this way has been proved by exposure of Petri dishes, and also by experiments with animals (mice).

## MELBOURNE.

**Royal Society of Victoria, June 8.**—Mr. F. Weis would in the chair.—Reuben T. Patton: On the drying of timber. An examination of moisture distribution in oak from winter to autumn seems to indicate that the moisture content of the heartwood is constant. Other trees, however, gave very extraordinary moisture distributions, and these emphasise the need for further investigation. Diffusion constants were obtained for some common timbers, and these show that oak has the lowest constant while pine has the highest. A study of the diffusion of moisture through the wood goes to show that the

fibre saturation theory does not hold. Work with cubes of green timber tends to show that drying from the end is about five times as fast as from a radial face. Thickness has no influence on the rate of drying. The curves of loss for a series of thicknesses form an envelope. The maximum temperatures and minimum humidities occurring in this state give very favourable drying conditions. Only at a humidity of 2 per cent. was the rate of drying adversely affected. The more rapid the drying the greater is the amount of shrinkage.—S. R. Tovey and P. F. Morris: The contributions from the National Herbarium of Victoria, No. 2. The paper contained a description of *Teucrium racemosum*, R.Br., var. *polymorpha*, Tovey and Morris. The variety differs from the type *T. racemosum* in having the stamens inserted in the corolla and the stigma only slightly exerted. Three new records of recent introductions were also given, viz. 1. A deciduous ornamental tree *Paulownia tomentosa*, Steud. (*P. imperialis*); 2. *Scorzonera laciniata*, L.: this plant is sometimes cultivated for its tapering root; 3. *Solanum triflorum*, Nutt., has made its appearance; it somewhat resembles the common Black Nightshade. The leaves are deeply cut (pinnatifid), the berries are about the size of a small cherry. In America the berries are considered poisonous. The active constituent is Solanin. The plant has been proclaimed under the Thistle Act for the whole State. The remainder of the paper consists of records of additional regional distribution of plants, also corrections in accordance with article 48 of the Vienna Botanical Congress (1905) and other notes of interest.

## CAPE TOWN.

**Royal Society of South Africa, July 19.**—Dr. J. D. F. Gilchrist, president, in the chair.—K. H. Barnard: Maps illustrating the zoological aspects of Wegener's disruption hypothesis. Stress was laid on the fact that on this hypothesis the land bridges connecting the southern continents into an enormous more or less equatorial continent were not required; that on the contrary the greater part of the old polar Gondwanaland was still in existence at the present day, and had never been beneath the sea since palaeozoic times. Consequently the distance, over which such groups as, e.g., the Acanthodrilæ Worms, Peripatopsidæ, Acavid Landshells, Cystignathid Frogs had had to travel was minimised. The extremities of these continents, hitherto regarded as peripheral, and containing primitive types driven thither by more specialised rivals, are seen to be really portions of the centre of Gondwanaland. The primitive and generalised types have always been approximately where we find them to-day, and their dispersal has been hindered and restricted, other than by physical causes, by the appearance of higher and more dominant types in other regions; e.g. the Acavidæ and Achatinidæ in South Africa and Ortman's classical explanation of the mutual exclusiveness of the Freshwater Crayfishes and Crabs. The concomitant expansion of an arm of the Indo-Pacific Ocean continually further between India and Australia, Africa and Antarctica, and extending eventually between Africa and South America (to form the Atlantic), was shown to have far-reaching consequences in aiding the dispersal of the marine fauna, e.g. the Silurid Fishes, Galaxias, and the ancestors of the Freshwater Crayfishes. Difficulties in the way of explaining certain features of the fauna of New Zealand, which has been permanently above the sea only since Tertiary times, were shown to be obviated by the new hypothesis.—W. H. Logeman: An easily constructed automatic Toepler vacuum pump.

# NATURE

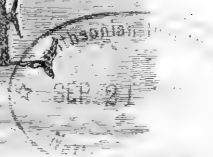

A WEEKLY ILLUSTRATED JOURNAL OF SCIENCE.

*"To the solid ground  
Of Nature trusts the mind which builds for aye."*—WORDSWORTH.

No. 2758, VOL. 110]

SATURDAY, SEPTEMBER 9, 1922

[PRICE ONE SHILLING

Registered as a Newspaper at the General Post Office.]

[All Rights Reserved.]

## NEWTON'S (New Model) "DEMONSTRATOR'S" LANTERN

For all classes of  
Projection Work.

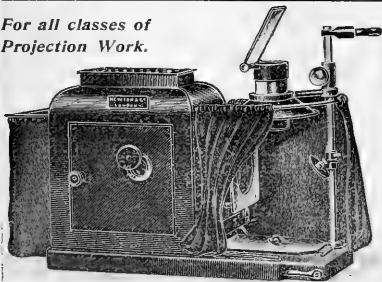

Full particulars sent on application.

NEWTON & Co., 72 Wigmore St., London, W.1.  
(Specialists in Optical Projection Apparatus.)

## REYNOLDS & BRANSON, LTD.

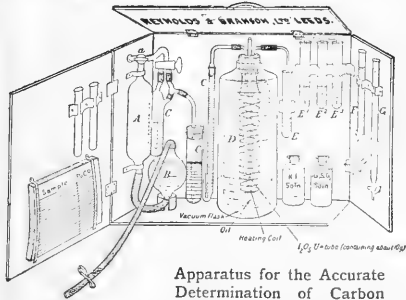

Apparatus for the Accurate  
Determination of Carbon  
Monoxide in Gas Mixtures.

Descriptive Pamphlet on Application.

14 COMMERCIAL STREET, LEEDS.

## BAIRD & TATLOCK (LONDON) LTD.

SCIENTIFIC INSTRUMENT MANUFACTURERS  
and LABORATORY FURNISHERS.

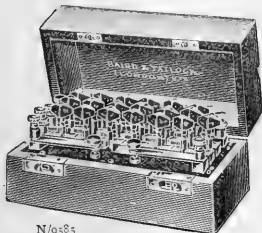

N/9385  
RESISTANCE BOX

Physical  
Apparatus  
for  
Schools  
and  
Colleges.

14-15 CROSS STREET, HATTON GARDEN, LONDON, E.C.1.

## HIGH RANGE THERMOMETERS

Of Guaranteed Accuracy.

NATIONAL PHYSICAL LABORATORY  
certificate of N. & Z. Thermometer No. D 10520.

Reading.	Correction.
212 F.	0 F.
300	0
400	0
500	+1
600	+1
700	0
805	0

Above is a copy of certificate of a Thermometer  
recently verified.

NEGRETTI & ZAMBRA  
38, HOLBORN VIADUCT, E.C.1.  
LONDON.

## THE SIR JOHN CASS TECHNICAL INSTITUTE,

JEWRY STREET, ALDGATE, E.C.3.

Principal—CHARLES A. KEANE, D.Sc., Ph.D., F.I.C.

**Evening Classes** designed to meet the requirements of those engaged in Chemical, Electrical, Metallurgical, Petroleum, and the Fermentation Industries and in trades associated therewith.

### CHEMISTRY.

H. J. S. SAND, D.Sc., Ph.D., F.I.C.  
E. DE BARRY BARNETT, B.Sc., F.I.C.  
P. C. L. THORNE, M.A., M.Sc., A.I.C.  
J. W. COOK, M.Sc.

### PHYSICS AND MATHEMATICS.

D. OWEN, B.A., D.Sc., F.Inst.P.  
R. H. HUMPHRY, M.Sc., A.Inst.P.  
A. E. R. CHURCH, M.A., B.Sc.  
G. F. ROSE, B.A.

### METALLURGY.

GEO. PATCHIN, A.R.S.M., M.I.M.M.  
W. A. C. NEWMAN, B.Sc., A.R.S.M., F.I.C.  
L. SINGLEHURST WARD, B.Sc.

### BREWING AND MALTING.

H. LLOYD-HIND, B.Sc., F.I.C.

### MICRO-BIOLOGY.

ARTHUR HARDEN, D.Sc., Ph.D., F.R.S.

### PETROLEUM TECHNOLOGY.

J. S. S. BRAME, F.I.C.  
J. MCCONNELL SANDERS, F.I.C.  
A. FRANK DABELL, M.Inst.Mech.E.  
J. L. JEFFERY, A.R.S.M., M.I.M.M.

### MECHANICAL DRAWING AND MATERIALS OF CONSTRUCTION AND DESIGN.

W. J. BURTON, O.B.E.  
B. HEASTIE, A.M.I.C.E.

### DIFFERENTIAL EQUATIONS AND VECTOR ANALYSIS.

A. E. R. CHURCH, M.A., B.Sc.

### ALTERNATING CURRENTS AND ELECTRICAL OSCILLATIONS.

D. OWEN, B.A., D.Sc., F.Inst.P.

### COLLOIDS.

E. HATSCHEK, F.Inst.P.

### METALLOGRAPHY AND PYROMETRY.

O. F. HUDSON, D.Sc., A.R.C.S.

### ANALYSIS OF ENGINEERING WORKS MATERIAL.

L. SINGLEHURST WARD, B.Sc.

### SCIENTIFIC AND TECHNICAL GERMAN.

W. R. SCHOELLER, Ph.D., A.I.C.

The Institute contains well-equipped laboratories in which every facility is provided for

### ADVANCED STUDY AND RESEARCH

both in the *afternoon* and *evening*.

Preparation for the Pass and Honours B.Sc. Examinations of University of London under recognised teachers of the University. The Institute is also recognised for the training of candidates for the Examinations of the Institute of Chemistry, and the Institute of Physics.

NEW SESSION COMMENCES SEPTEMBER 25.

ENROLMENT WEEK, Monday, September 18, to Friday, September 23, 6.30 to 8.30 P.M.

For details of courses apply at the Office of the Institute or by letter to the PRINCIPAL.

## CHELSEA POLYTECHNIC,

CHELSEA, S.W.3.

Session begins September 25, 1922.

Day and Evening Courses in Science under Recognised Teachers of London University.

### I. INDUSTRIAL CHEMISTRY DEPARTMENT.

Technical Courses in Analytical and Manufacturing Chemistry, Pharmacy, Food and Drugs, A.I.C. Courses, Metallurgy, Assaying, Foundry Work, Research.

### II. INDUSTRIAL PHYSICS DEPARTMENT.

Practical work in General Physics, Applications to Industries, Metrology, Calorimetry, Illumination, Acoustics, Electrical Measurement, Research.

### III. BIOLOGICAL AND GEOLOGICAL DEPARTMENT.

Courses for B.Sc., etc., in Botany, Geology, Mineralogy, Zoology, Special Courses in Bio-chemistry, Bio-physics, Bacteriology, Physiology, Hygiene, Entomology, Plant Pathology. Course for Tropical Planters, Research.

SIDNEY SKINNER, M.A.,  
Principal.

Telephone: Kensington 899.

## BIRKBECK COLLEGE.

(UNIVERSITY OF LONDON.)

Principal—GEORGE SENTER, D.Sc., Ph.D., F.I.C.

**EVENING COURSES** for the Degrees of the University of London in the Faculty of Science and for the Geography Diploma.

Facilities are also provided during both day and evening for Post-Graduate and Research Work.

Calendar, 1s.; by post, 1s. 5d. Prospectus free.

For full particulars, apply to the SECRETARY, Birkbeck College, Fetter Lane, E.C.4.

## MANCHESTER MUNICIPAL COLLEGE OF TECHNOLOGY

Principal: B. MOUAT JONES, M.A. (Oxford)

The Session 1922-1923 will open on 5th October. Matriculation and Entrance Examinations will be held in September. Students will be enrolled on 2nd, 3rd, and 4th October, between 10 a.m. and 1 p.m., and 2 p.m. and 4 p.m.

### DEGREE COURSES IN TECHNOLOGY

The Prospectus gives particulars of the courses leading to the Manchester University degrees (B.Sc.Tech. and M.Sc.Tech.) in the Faculty of Technology, in the following Departments:

MECHANICAL, ELECTRICAL, and SANITARY and MUNICIPAL ENGINEERING.

THE CHEMICAL INDUSTRIES, including General Chemical Technology, Bleaching, Dyeing and Dyestuff Manufacture, Printing, Papermaking, Fermentation Industries, Metallurgy, Fuels.

TEXTILE INDUSTRIES, PHOTOGRAPHIC TECHNOLOGY

For Advanced Study and Research the College possesses extensive laboratories and workshops containing machines specially constructed for demonstration and original research.

Prospectus sent free on application to the Registrar.

## BATTERSEA POLYTECHNIC,

LONDON, S.W.11.

Principal—ROBERT H. PICKARD, D.Sc., F.R.S.

Day Technical College in preparation for Polytechnic Diplomas in Mechanical, Civil and Constructional, and Electrical Engineering, Chemistry, Mathematics, and Physics, and for B.Sc. and B.Sc. (Eng.) Pass and Honours Degrees of the University of London.

Training College of Domestic Science in preparation for Teachers' Diplomas in Cookery, Laundrywork, Housewifery, Needlework, Dressmaking, and Millinery.

Department of Hygiene and Public Health for the training of Sanitary Inspectors, Health Visitors, Welfare Workers, etc.

School of Art and Crafts for training in Drawing and Design, Fashion Plate Drawing, Applied Art, etc.

Hostels for Women Students.

Evening Courses in preparation for University of London Degrees in Science, Engineering and Music, and in Mechanical and Electrical Engineering, Mathematics, Physics, Chemistry, Art and Crafts, Civil Service Subjects, Domestic Science, Music and Physical Training.

Next session begins on Tuesday September 19, 1922.

Full particulars of all classes on application to the Principal.





SATURDAY, SEPTEMBER 9, 1922.

## CONTENTS.

	PAGE
Animal Mechanism . . . . .	333
The United States Chemical Foundation . . . . .	334
Galton's Centenary . . . . .	335
Modern Dietics . . . . .	336
Germany and English Chemical Industry . . . . .	337
Railway Electric Traction . . . . .	338
Our Bookshelf . . . . .	339
Letters to the Editor :—	
The British Association.—Prof. Henry E. Armstrong, F.R.S. . . . .	341
Bohr and Langmuir Atoms.—Sir Oliver Lodge, F.R.S. . . . .	341
The Acoustics of Enclosed Spaces.—Sir Arthur Schuster, F.R.S. . . . .	341
The Annelids of Iceland and the Faroes.—The Rev. Hilderic Friend . . . . .	342
On the Reality of Nerve-Energy.—Prof. D. Fraser Harris . . . . .	342
Noctiluca as an Enemy of the Oyster.—R. W. Dodgson . . . . .	343
Defoliation of Oaks.—Right Hon. Sir Herbert Maxwell, Bart., F.R.S. . . . .	344
Black Coral.—Dr. F. A. Baher, F.R.S. . . . .	344
Metallic Coloration of Chrysalids.—A. Mallock, F.R.S. . . . .	344
The British Association at Hull. By T. S. . . . .	345
Some Aspects of Animal Mechanism. By Sir C. S. Sherrington, G.B.E., Sc.D., D.Sc., LL.D., Pres. R.S. . . . .	346
Scientific Problems and Progress. ADDRESSES OF PRESIDENTS OF SECTIONS OF THE BRITISH ASSOCIATION . . . . .	352
The Royal Observatory, Greenwich ( <i>Illustrated.</i> ) . . . . .	356
Colour Vision and Syntony. ( <i>With Diagram.</i> ) By Prof. E. H. Barton, F.R.S. . . . .	357
Obituary :—	
Prof. J. A. Pollock, F.R.S. . . . .	359
Prof. Tadeusz Godlewski. By R. W. L. . . . .	361
M. L. Favé . . . . .	361
Current Topics and Events . . . . .	362
Our Astronomical Column . . . . .	362
Research Items . . . . .	365
The First Messel Memorial Lecture . . . . .	367
Stellar Radiation in the Infra-red . . . . .	367
University and Educational Intelligence . . . . .	368
Calendar of Industrial Pioneers . . . . .	368

*Editorial and Publishing Offices :*

MACMILLAN & CO., LTD.,

ST. MARTIN'S STREET, LONDON, W.C.2.

Advertisements and business letters should be addressed to the Publishers.

Editorial communications to the Editor.

Telegraphic Address: PHUSIS, LONDON.

Telephone Number: GERRARD 8830.

NO. 2758, VOL. 110]

## Animal Mechanism.

THE presidential address of Sir Charles Sherrington to the British Association at Hull directs our thoughts to problems of the mechanism of vital processes, especially to those of the nervous system. It is evident that the obstacles which we meet with in our progress to better understanding of what happens in those complex systems which we call "living" have greatly occupied the attention of the learned president, and those of us who are struggling on our way will be grateful for his helpful and stimulating outlook. We shall do well to take careful note of his remarks.

The great difficulty which continually presents itself to us is the conception of any physiological process as a whole. We find out, often at the expense of much labour, some isolated facts, but the integration of these facts to explain the complete mechanism remains beyond our powers. Take the case of muscle. We discover that muscular contraction and relaxation are associated with a change from glycogen to lactic acid and back again. But how is the energy of the chemical reaction converted to that of tension, which is the really important matter? It is easy to say that it is through changes in surface tension on longitudinally arranged elements, but we soon meet with further difficulties. It may be remarked that more work is needed on the electrical properties of surfaces and especially as to the effect of electric charge on the rate of passage of ions through membranes which are themselves charged. The problem in the nervous system shows itself in the form of finding out what happens in the centres between the receipt of an afferent "sensory" impulse and the motor reaction to it. How is the impulse directed into some particular channel and prevented from passing into another? Why does it go sometimes one way, and at other times in another way? What is it that stops it after it has been set going? The president is careful to point out that when the physiologist says "why" he means "how," and we must not forget this.

It will be realised that one of the most important and difficult problems, especially suggested in the last of the questions put above, is that of inhibition. Is it possible to account for all the phenomena on the basis of difference in rate, refractory period and decrement as affecting the transmission of a nervous impulse? The article on "Spinal Reflexes" by Prof. Alex. Forbes in *Physiological Reviews* gives us a very valuable account of what can be done in this way. On the other hand, is there evidence for the existence of something essentially different between excitation and inhibition? When a nervous impulse arrives at a muscle cell or a neurone in activity, is there some

structure in which it ends that causes it to stop abruptly the process going on? In other words, are there two opposite processes of excitation and inhibition, similar in nature but opposite in sign? We come across the old problem of duality, of some philosophical interest. The question as to the existence of positive and negative electricity, as in the nucleus and electrons of an atom, is a cognate one, and we are reminded of the frequent physiological opposition between anions and cations.

With respect to the hope or probability of further progress in the explanation of vital processes, Sir Charles Sherrington directs attention to the justification that what has already been done gives us in believing that "further application of physics and chemistry will furnish a competent key" to many mechanisms. Although we may not be able to construct such mechanisms ourselves, we may understand the principles on which they work, somewhat as a man may be able to explain how an electro-motor works, notwithstanding that he may not have the skill to make one. There are, however, other things, more particularly concerned with growth and development, which we, as yet, are a long way from comprehending. What it is that makes a living creature a united whole and "how the mind is connected with its bodily place" belong to these. The question is asked, "Can we suppose a unified entity which is part mechanism and part not?"

The latter part of the address is devoted to some important relations of the physiology of the brain to the doctrines of psychology and sociology. We must not leave out of consideration the combination of individuals into social organisms, "new in the history of the world." Man must feel that to rebel against this great supra-individual process "would be to sink lower rather than to continue his own evolution upward."

There are many apposite points brought out in the discussion on the "mental" functions of the brain. We know that the integrity of certain parts of the brain is essential for mental activity, while what we call the lower levels are non-mental. Since we step from one world to another, as it were, when we pass from a nerve impulse to a psychical event, we might expect that there would be some striking change of structure when we cross the boundary between the non-mental and the mental regions of the brain. But we find the "same old structural elements." "The structural inter-connections are richer, but that is merely a quantitative change." Another difficult problem is the position of psychical events in the energy balance-sheet of the body. Do they take their place in obeying the first law of energetics? But the whole of this discussion must be read in the address itself to be properly appreciated.

### The United States Chemical Foundation.

EARLY in July last, President Harding instructed the Alien Property Custodian of the United States to demand the return of all patents, trade marks, etc., which had been sold to the Chemical Foundation, on the ground that "the sale was made at so nearly a nominal sum that there is reason to believe that this government has not faithfully observed the trust which was implied in the seizure of this property." The birth of the Foundation was the subject of much abuse in Germany, and now a resolution of the third German-American National Conference, with Mr. G. S. Viereck as chairman of the resolutions committee, declares that "we greet with satisfaction the first steps of the administration to correct the iniquities committed by the custodian of alien enemy property." Meanwhile, the consternation produced among chemists of the United States by the President's action will be readily understood.

The Chemical Foundation was established in 1919, and purchased 4000 patents from the Alien Property Custodian for a sum of 250,000 dollars. It is a privately managed enterprise, with well-known men of high character as voting trustees, and the president, Mr. Garvan, is not salaried. The Foundation was generally commended at the time of its inception, and its affairs appear to have been conducted on altruistic principles and without profit. Non-exclusive licences have been granted in order to break monopolies and to benefit consumers; licences to the Government have been free, and on others the royalties have been low. To illustrate the beneficial effect of this policy, it has been stated that under the German monopoly the cost of salvarsan was 4.50 dollars per dose to the physician, and 2.50 dollars per dose in quantity to the Government, whereas now the price has fallen to 1.50 dollars and about 30 cents, respectively.

A reasonable conclusion to draw from such evidence is that although the original price paid by the Foundation for the patents may have been "nearly a nominal sum" if regarded as a monopoly price, it was nevertheless a fair competitive price. Action is being taken by the American Chemical Society, which represents some 15,000 men and women working in educational institutions, research laboratories, and industrial plants, who regard the Chemical Foundation as the nucleus of organic chemical industry in the United States. The society, through a committee which does not include dye-makers or chemical manufacturers, is seeking a conference with President Harding for the purpose of presenting information which it believes he cannot have received before adopting such revolutionary procedure.

## Galton's Centenary.

*Francis Galton, 1822-1922: A Centenary Appreciation.*

By Karl Pearson. (Department of Applied Statistics, University College, London. Questions of the Day and of the Fray, No. 11.) Pp. 23. (London: Cambridge University Press, 1922.) 2s. net.

PROF. KARL PEARSON does not think that this generation is likely to do justice to the part Sir Francis Galton played in the spread of human knowledge and in its application to the future of the human race. His own appreciation he would have others share, and he whips them with scorpions as an inducement. As he says, "the time is hardly suited to impressing on the majority of men a conviction of the futility of most of their aims, of the depths of their ignorance of what makes for progress, and of the unsatisfying nature of their present pleasures."

The welcome appreciation begins with an account of Victorian science, the science of Darwin, Lyell, Hooker, Faraday, and other giants, which, he says, little men belittle—for it is impossible to appreciate Galton unless we bear in mind that he was the product of the Victorian epoch. Endowed with a fine inheritance, Francis Galton had the advantage of broad training and wide experience, very different from the early specialisation of to-day; "he had far more mathematics and physics than nine biologists out of ten, and more biology than nineteen mathematicians out of twenty, and more acquaintance with diseases and anomalies than forty-nine out of fifty biologists and mathematicians together." Darwin awoke him from "the torpor of tribal dogmas," and turned his widely interested mind to the problems of evolution. Along both observational and experimental lines, he began to study sweet-peas, moths, and man. "In his notebook on the sweet-pea experiments occur the first correlation table, the first regression curve, and the first numerical measure of the intensity of heredity, *i.e.* that between mother and daughter plant." From Mendel's peas has arisen the greater part of modern genetics; from Galton's there sprang the correlational calculus, solidly founded in "Natural Inheritance" published in 1889.

Darwin had suggested, contrary to his usual method of keeping to observed facts, the hypothesis of "pangenesis," that hereditary particles or gemmules given off from the various structures of the body are concentrated in the reproductive cells, and influence the development of these into new individuals. Galton suggested an experimental test, transfusing the blood of different kinds of rabbits to see if the offspring were influenced. The results showed that the transfusion

had no effect on the offspring, and Galton tacitly discarded pangenesis. But continued reflection led him, as it also led Weismann, to the idea of germinal continuity. We believe that the idea of parent and child being successive representatives of the same "stirp" or germ-plasm had occurred, more or less clearly, to two or three other biologists before either Galton or Weismann; but Prof. Karl Pearson seems to find something "little" in directing attention to historical anticipations. There is no doubt, however, that "Galton's idea of the 'stirp,' better known under the name given to it by its later German proponent [we should say, 'independent discoverer'], the 'continuity of the germ-plasm,' has played a very large part in modern theories of heredity." It has indeed enabled biologists to understand for the first time clearly why like *must* tend to beget like.

From the fundamental idea of germinal continuity there arose in Galton's mind two broad principles, (1) that bodily modifications, or "acquired characters" in the technical sense, are not likely to be transmitted; and (2) that the differences in the characters of the offspring produced by a difference of stirp are immensely more important than those which can be produced by differences of environment. From his study of identical and non-identical twins he concluded that "nature" is indefinitely stronger than "nurture." We confess to sympathy with what Prof. Pearson calls the platitude that "nature" and "nurture" are inseparably correlated as two essential components of one resultant. Moreover, we feel sure that Galton was naturalist enough to know that improvements in "nurture" may determine the meshes of the sieve in relation to which germinal fluctuations and mutations—better and worse changes in "nature"—are sifted.

It is plain, however, that pondering over the relative evolutionary values of "nature" and "nurture" led Galton to the question which dominated the rest of his life: what evolution may mean for man. What Pasteur was along one line, Galton was along another, a pioneer in the biological control of life. Can man's constitution—in modern phraseology, his gametic composition—be improved, by mating best with best, and fit with fit, and by refraining from sowing tares with wheat? Or may we hope to effect some progress by amelioration of "nurture"—environmental, nutritional, and functional? For improved "nurture" may prompt, for all we know, progressive germinal variations; may determine the survival or elimination of variations; may, in viviparous organisms, count for much in the ante-natal life; and may, in mankind, have an almost hereditary influence on the amelioration of the social *milieu*. Galton's view was that the improvement of the human *breed* was the promiseful line

of evolution, but we cannot think of him as failing to appreciate the manifoldness and the subtlety of nurtural influences, both on the individual and on the race.

Prof. Pearson gives us in his masterly appreciation a useful tonic. "The laws of evolution are open to our study, let us once understand them, and man can elevate man as he has developed his domestic animals—such was the gospel of Galton." Here we are all agreed, Galton was a great man of science and also a social reformer; and it is a satisfaction to all men of goodwill that he continues to live with such vigour in the Laboratory which he founded. The appreciation has as its frontispiece a beautiful sketch of Sir Francis Galton in 1910, in his "still unexhausted exuberant youth."

### Modern Dietetics.

*Vitamins and the Choice of Food.* By Violet G. Plimmer and Prof. R. H. A. Plimmer. Pp. xii + 164. (London: Longmans, Green and Co., 1922.) 7s. 6d. net.

THE old view that a diet was satisfactory, provided it contained a certain amount of protein and had a sufficient calorie value, has, as is now well known, been modified in two very essential particulars. The quality of the protein is of the first importance; it must supply the particular amino-acids required by the consumer, and must supply them in the proper amount. Further, there must be present the vitamins, the exact nature and function of which are still unknown, but which are essential for growth and health.

It is to these two aspects of the subject that the present work is chiefly devoted, the authors having set themselves the task of producing an account suitable for the general reader. In this they have been on the whole successful, although occasionally the superabundance of facts renders the matter difficult of assimilation. After an introduction dealing with the general principles of dietetics, the subject of the vitamins and their discovery is developed on orthodox lines. The important question of quality of protein, led up to and illustrated by an account of pellagra, is then treated, and the book concludes with two very interesting chapters on the effect of partial deficiencies in the food and errors in selection of food. In an appendix are given a table of distribution of the vitamins in food-stuffs and lists of food-stuffs rich in each of the three vitamins, followed by a very useful series of notes on food-stuffs, from which a good idea of the efficiency of a diet can be easily and rapidly

obtained. The book is well produced and contains a number of interesting illustrations.

It is an inevitable consequence of the rapid progress which is being made in this branch of dietetics that the position with respect to some of the matters dealt with has changed considerably since the book was printed. This is notably the case with regard to rickets, the very recent work of McCollum and of Korenchevsky on experimental rickets in rats, and the remarkable discovery of the preventive and healing effect of sunlight on this disease, having come too late for inclusion. Similarly, the large part played by atmospheric oxidation in the inactivation of the antiscorbutic vitamin is not made clear.

The gospel preached by the authors is the orthodox one that safety is to be found in fresh natural food-stuffs, and it is wisely pointed out that instinct, often believed to be a guide to the choice of food, is no longer so under the conditions of modern civilisation. White bread, for example, almost universally preferred in this country, is far inferior in vitaminic potency to whole-meal or "germ" bread, and no instinctive need is felt for green vegetables and salads. The choice of food must be guided by knowledge, and it is pointed out that the distribution of food within the family is often conducted on quite erroneous principles.

"Children are supposed to be sufficiently nourished if they have bread and jam and plenty of puddings with little meat or butter. It is unfortunately the custom to give to the fatten or wage-earner the best food, whereas his requirements for heavy manual work are actually better satisfied by the high energy value of bread, jam, and margarine. The child needs the wherewithal to grow, that is protein and vitamins in addition to calories."

It is in the provision of fresh vegetables to supplement the staple diet of bread, margarine, and meat, all very poor in vitamins, that the chief value of the allotment movement lies (as pointed out by Drummond), and it is to be hoped that the great extension of this system which was called forth by the necessities of the war will be maintained and still further increased in the scarcely less strenuous times of peace.

Even natural food-stuffs, however, are by no means constant in their content of vitamins. Little is known as yet of the cause of the variations in vegetable products at different periods of growth and under diverse conditions, but that wide variations occur has been definitely proved. In products derived from animals this variation is still more marked, and the authors rightly lay stress on this fact, pointing out that the potency of materials such as animal fats, and above all milk, depends upon the diet of the animal from which it is derived.

"The milk of cows at grass contains more A-factor than the milk of the same cows on their winter food. . . . At certain times of the year a child receiving fresh whole cow's milk may for this reason only be getting a small amount of this vitamin. . . . Breast-feeding is no protection against rickets if the mother's food is poor in A-factor."

The provision of fresh natural food-stuffs, although greatly to be desired, is a matter of much difficulty, especially in large towns, and is often impossible when military expeditions or explorations in barren regions have to be undertaken. Then the problem of preserving food-stuffs without destruction of their vitamins becomes of great interest and importance. The chief methods for the prolonged preservation of food are canning or bottling and drying, and a considerable amount of investigation has already been directed to the question how far these methods of treatment affect the vitamins. Up to the present, however, sufficient attention has not been paid to the influence of oxidation in these processes. The results so far obtained vary very much with the nature of the material employed. Thus vegetables on drying, as a rule, undergo a considerable loss of antiscorbutic power, that of cabbage being reduced by drying in the air at 37° to about 5-10 per cent. of the value of the fresh material. (The authors are not quite clear on this point, the somewhat misleading statement being made that "cabbage has been successfully dried by a special process devised by Holst and Fröhlich.") Retention of antiscorbutic power by material in the dry state seems to depend on the complete absence of moisture.

Heat sterilisation as applied in bottling and canning processes affects the antiscorbutic more than the other two vitamins, but the influence of oxidation is very great. However, it has been found in practice that a material originally rich in the vitamin, like the tomato, will withstand the commercial process and yield a powerfully active product, canned tomatoes having been successfully used for the prevention of scurvy. Again, lemon-juice in presence of the natural oil of the rind retains its potency for long periods. There seems, indeed, to the writer, to be no insuperable difficulty in the way of the provision of preserved foods containing at all events a large proportion of their original vitaminic potency. Much further investigation on this subject, on strictly quantitative lines, is, however, required, and at present each case must be separately examined, no generalisation being as yet justified. It is, moreover, not beyond the bounds of probability that some method will before long be found of enriching cheap edible oils so that they may supply vitamin A as well as energy at a reasonable cost.

Interesting problems are suggested by almost every

page of this book, and it cannot fail to be of great value in disseminating sound doctrine on a subject concerning which there is now widespread ignorance.

### Germany and English Chemical Industry.

*Englands Handelskrieg und die chemische Industrie.* Von Prof. Dr. A. Hesse und Prof. Dr. H. Grossmann. Band 1. Pp. iv+304. Band 2: Neue Folge. *England, Frankreich, Amerika.* Pp. iv+344. Band 3: *Dokumente über die Kali-, Stickstoff- und Superphosphat-Industrie.* Herausgegeben von A. Hesse, H. Grossmann, und W. A. Roth. Pp. iv+204. (Stuttgart: F. Enke, 1915-1919.) 98 marks.

THIS work consists of a series of translations of lectures, speeches, and articles by English, French, American, Russian, and Italian chemists, and by certain publicists like Lord Moulton, and by public bodies as the British Science Guild, which appeared at the outbreak of the Great War, or immediately prior to it. In addition, a number of utterances by public men and others, of more or less importance, have been culled from newspapers and the periodical press to support what is the apparent purpose of the publication, namely, to insinuate that the real motive which impelled England to participate in the war was her distrust and jealousy of Germany's industrial pre-eminence, especially in the chemical arts, and her consciousness that she was losing the world's markets owing to Germany's greater technical skill and scientific knowledge, and her better business organisation and financial methods. This idea is implied in the title of the work. It has been sedulously propagated in Germany that the real author of the war was England, and that it was solely to her diplomacy that the catastrophe was brought about—an explanation, and it may be added an exculpation, which doubtless commends itself to the soul of the Teuton.

There is, of course, no necessity to refute an implication which is notoriously at variance with the facts, and is certainly not held by ordinarily well-informed people, even in Germany. But it is characteristic of German mentality that it should have been seriously entertained even in 1915, when the first volume of this work was issued, and that persons of the position of its editors should have been found to support it.

The translations of the English lectures and addresses, most of which have appeared in the recognised journals dealing with applied chemistry, seem to have been well rendered, although exception may occasionally be taken to the comments and explanatory notes which the editors have appended. But it is more

particularly to the tone and purport of the introductory matter which prefaces the several volumes, and for which they are solely responsible, that exception is chiefly to be taken.

At the same time there is an element of unconscious humour about the whole production. In view of the hardihood with which they reproduce, for the benefit of German readers, the many strictures on German commercial methods with which they have been visited, one is tempted to suggest that their knowledge of our national literature might have disposed the editors to prefix as a motto on their title-page the lines :

O wad some power the giftie gie us  
To see oursels as others see us !  
It wad frae monie a blunder free us  
And foolish notion.

But possibly these strictures are really considered by them as implying a compliment to what they regard as their business acumen, but what other people are apt to characterise as "slimness."

### Railway Electric Traction.

*Railway Electric Traction.* By F. W. Carter. Pp. viii + 412. (London: E. Arnold and Co., 1922.) 25s. net.

THE problems of electric traction on railways deserve special study at the present time. In the past, electrification has been adopted, as a rule, only when abnormal difficulties, such as the existence of a long tunnel, busy urban traffic, very steep gradients, or a very high price for fuel, had to be overcome. It will be remembered that, largely as the result of a tunnel accident attributed to an accumulation of noxious gases, the New York authorities insisted that practically all lines entering the city should be electrified. The underground railways of London, the Simplon tunnel, and the Belt line tunnel of the Baltimore and Ohio Railway, electrified so long ago as 1895, are further examples. The Norfolk and Western Railroad, a heavy goods line, was electrified because of its long and steep gradients. For the same reason the Chicago Milwaukee and St. Paul Railway, which crosses the Rocky Mountains, had to electrify several of its sections. The development of electric railways in Switzerland, in Sweden, in Bavaria, and in Italy is mainly due to the high price of fuel in these countries.

It does not follow, however, that electric traction should be used only when special difficulties have to be overcome. When steam operation is a commercial success, the justification of electrical operation must be that it provides increased transport facilities with

no increase in the rates. With steam operation individual power generation is employed, whereas with electrical operation the power is developed in bulk at central stations. In the electrical system a breakdown at a vital point may stop traffic over a wide area, and to obviate this risk a large amount of capital has to be expended in stand-by plant. In several cases, however, it is more advantageous for the railway to purchase its power from a "bulk supply" station. A disadvantage of a steam locomotive is that it consumes fuel so long as it is in commission; whether it is inside or outside the shed, and whether it is at rest or in motion. Tube-cleaning, oiling, and overhauling also occupy a considerable time. The electric locomotive, on the other hand, takes power only when running, and the time spent in inspection, overhauling, and cleaning is insignificant. Experience shows that for a given service the number of electric locomotives required is less than half the number of steam locomotives, but to make the comparison fair it has to be remembered that each electric locomotive must be debited with its share of the working costs of the central station.

The advisory committee of the Ministry of Transport has decided in favour of the direct current system, with a line pressure of 1500 volts, but multiples or submultiples of this pressure may be used. The French, Belgian, and Netherlands governments have come to a like decision. There are, however, thoughtful advocates of single-phase and polyphase systems. Luckily the difference in cost of the various electric systems does not exceed about one, or at the most two, per cent. of the total cost of running the railway. Although from many points of view standardisation of systems is desirable, yet we think that at the present time the carrying out of the single-phase system adopted by the London and Brighton Railway and the direct current system of the North Eastern Railway will be for the benefit of the country.

In the volume under notice the author gives an excellent discussion of the mechanical and electrical problems which traction engineers have to consider. He points out that the bad riding qualities of a locomotive are due to one or both of two general causes, namely, the constraint of the wheels to follow other courses than those towards which they naturally tend, and the setting up of resonant oscillations under the control of the springs. The phenomena of "nosing" and "rearing" he ascribes to the former cause, and those of "rolling" and "pitching" to the latter.

The book can be recommended to the traction engineer, who will find not only a good account of the most modern practice, but also many original dynamical discussions which have a direct bearing on his everyday work. It will well repay study.

## Our Bookshelf.

- (1) *Hampshire*. By T. Varley. (Cambridge County Geographies.) Pp. xi + 212. (Cambridge: At the University Press, 1922.) 3s. 6d. net.
- (2) *Munster*. Pp. xii + 176. (3) *Ulster*. Pp. xii + 186. (The Provinces of Ireland.) Edited by George Fletcher. (Cambridge: At the University Press, 1921.) 6s. 6d. net each.
- (4) *A History of the County of Bedford*. (The Victoria History of the Counties of England.) Part 1, *Geology and Palaeontology*. Pp. 36. (London: Constable and Co. Issued in parts, 1920.) 3s. 6d. net.

(1) MR. VARLEY'S volume is one of the excellent series of the Cambridge County Geographies. The general plan of the series is followed, successive chapters being devoted to different aspects of the county, relief, geology, hydrography, natural history, climate, people, place-names, occupations, history, architecture, and so forth, concluding with a gazetteer of towns and villages. There are a number of illustrations and coloured orographical and geological maps. The maps include the Isle of Wight, which otherwise is outside the scope of the book, but unfortunately they stop short at the county boundaries. This seems to be a needless curtailment of their usefulness. The volume is an excellent handbook to the county and is full of information, but it certainly would be improved by an index. Two criticisms may be offered, which apply rather to the scheme of the series than to this useful volume in particular. The treatment of England by counties can never be completely satisfactory, as it inevitably cuts across geographical regions. Thus the omission of eastern Wiltshire cuts out part of the Avon valley, while the inclusion of the northern slope of the Hampshire downs includes a fragment of country that would be better treated with Berkshire. The other criticism refers to the use of the term geography, as applicable to the book. Since the series claims to be geographical, there should be more correlation of various distributions than is actually the case in the pages; causal effects are not sufficiently emphasised. This is particularly the case with regard to the distribution of population and the sites of towns.

(2) and (3) These volumes are on much the same plan, but they do not claim to be geographies, although in some respects the two volumes are more geographical than the English one. The coloured maps are not strictly confined to the area under consideration, and the regions treated being large, if not always naturally defined, lend themselves to more satisfactory treatment. There is no gazetteer of towns and villages, but a full index to each volume. The books should find a wide acceptance in giving a trustworthy and impartial account of Ireland.

(4) The well-known Victoria History is now published in parts, each of which may be purchased separately. It is thus possible to obtain a full but concise memoir on the geology, botany, zoology, occupations, etc., of each of the counties, furnished with coloured maps by Bartholomew. The separate parts for some thirty counties are now on sale. Many readers whose interests do not embrace all aspects of county lore will be grateful to the publishers for this means of making accessible the scholarly articles of the Victoria History.

*A Synopsis of the Accipitres (Diurnal Birds of Prey)*. Part 1 (Vultur to Accipiter). Part 2 (Erythrotriorchis to Lophoetus). Part 3 (Herpetotheres to Pernis). By H. Kirke Swann. Second edition, revised and corrected throughout. Pp. 1-63, 65-122, 123-178. (London: Wheldon and Wesley, Ltd.) 6s. each part.

THE work issued in 1920 as "A Synoptical List of the Accipitres" has now reappeared in an enlarged and revised form under the above title. The new edition affords original descriptions of a number of new sub-species; includes others which have appeared elsewhere; gives the type-species of each genus; the type localities of each species; and, alas, further changes in nomenclature. The Synopsis will be most appreciated by those who have some knowledge on the subject, for the extreme brevity of its descriptions of the ordinal, generic, specific, and sub-specific characters will not be of much help to the general student. The diagnostic characters of the species are restricted to adult plumages, and leave untouched the immature stages, which are the most difficult of all. The treatment of the geographical range of the various forms is also very brief.

A monograph of the Accipitres is an admitted desideratum, and as Mr. Kirke Swann has evidently devoted much attention to their study, perhaps he will supply the want. Such a treatise dealing with the plumages, distribution and life-histories would be much appreciated, especially as the birds of this order are among the most attractive and interesting of the class Aves.

*Life-histories of North American Gulls and Terns. Order Longipennes*. By Arthur Cleveland Bent. Bulletin No. 113. (Smithsonian Institution, United States National Museum.)

THIS is the second instalment of an important work on the life-histories of North American birds—the first of which, dealing with the order Pygopodes, has already been noticed in NATURE.

In this volume Mr. Bent, who possesses an intimate personal knowledge of the birds of the order Longipennes, gained during extensive travels as well as in the laboratory, has been fortunate in securing the co-operation of a number of field-naturalists; and their combined experiences, supplemented by important published matter, has resulted in a remarkable series of life-histories of the fifty species of gulls and terns which are members of the Nearctic avifauna.

Under the description of each of the birds there are sections devoted to habits, nesting, eggs, young, plumages, food, behaviour, and distribution. All of these are treated in an interesting manner, and are made further attractive by a series of beautiful coloured plates, 38 in number, depicting the eggs of each species; while a second series of 77 plates, from photographs, illustrate breeding colonies, sitting-birds, nests, chicks in down, half-feathered young, and haunts. The work, apart from the absence of coloured figures of the adult birds themselves, is wonderfully complete, and is a valuable contribution to ornithological literature.

*The Individual and the Community.* By R. E. Roper. Pp. 224. (London: G. Allen and Unwin, Ltd., 1922.) 8s. 6d. net.

MR. ROPER has produced a thoughtful and, in many respects, a stimulating book. He is a whole-hearted evolutionist, who regards the failure of post-war reconstruction as arising from the fact that our statesmen have resorted to outworn precedents while neglecting the teachings of evolution. There is, he maintains, a wilful confusion of State and community. A community he defines as "an association of two or more human beings for common (though not of necessity identical or similar) purpose or advantage in their evolution." Immediately the common purpose ceases, the community also ceases. Taking each of the principal States of Europe in turn, Mr. Roper shows that, owing to the division which has been made and is perpetuated by the financial-governing class between themselves and the working-governed class, none of them constitutes a community in his sense. The imposition of the will of one section of society upon another which is involved in our modern system of government by the majority is therefore fundamentally wrong. The difficulty is old, and if in practice we have made no very essential advance beyond the compromise expressed in Rousseau's distinction between *le volonté de tous* and *le volonté général*, it is an advantage that it should be kept before our minds by the clear vision of writers such as Mr. Roper.

*Metric System for Engineers.* By C. B. Clapham. (Directly-Useful Technical Series.) Pp. xii+181+3 charts. (London: Chapman and Hall, Ltd., 1921.) 12s. 6d. net.

THE author's justification for his book is that "even among those who use the millimetre in drawing-office or workshop there are probably few who feel confident in calculating with metric units," and his object is to explain the metric system and to state in full how to convert from the English units to metric units, and *vice versa*. Incidentally there is given an excellent account of the vernier and other devices used by engineers for accurate measurement. The book should be of great use in industrial life: the conversion tables are very exhaustive.

A brief survey is offered of the controversy which has been raging for so long round the question whether the metric system should or should not be introduced compulsorily in this country. It is claimed that this survey is not a piece of propaganda work in favour of the change, but the arguments given *pro* and *con* do much to support the view, that a good deal of the opposition to the enforced use of the metric system in England is attributable to mere conservative objection to change. Mr. Clapham's book is itself one of the best arguments in favour of the change—why should the Englishman be condemned to waste so much time and energy in making conversions and in looking up tables of equivalents? S. B.

*Wild Bush Tribes of Tropical Africa.* By G. C. Claridge. Pp. 314. (London: Seeley, Service and Co., Ltd., 1922.) 21s. net.

MR. CLARIDGE'S "Bush Tribes" are the Ba-Congo of Northern Angola, and the country the inhabitants of which he describes stretches from the Congo on the north

to St. Paul de Loanda in the south, and from the Kwilu and Kwangu rivers in the east to the Atlantic. He writes of the native with sympathy, but, for the most part, despises his customs: he rarely fails to stigmatise them as "degrading," "disgusting," or worse when he has an opportunity. Notwithstanding this drawback, as it must seem to those who wish to study native custom impartially, the author has given a full and careful account of Ba-Congo culture, and his collection of folk-lore is both interesting and useful. The most important part of his book deals with fetishism, and, in particular, with the N'Kamba fetish of the women, which controls their most important function, that of child-bearing. The men are rigorously excluded from the rites of this fetish. A "Death and Resurrection" secret society, which effects "cures" by death and rebirth, is described from information supplied by a native, but here unfortunately the author's prejudice colours the narrative to such an extent that considerable knowledge of similar societies is required to disentangle the facts.

*Readable School Physics.* By J. A. Cochrane. Pp. xi+131. (London: G. Bell and Sons, Ltd., 1922.) 2s. 4d.

A TEACHER who loves his subject will find matter of interest for his pupils even in its most prosaic parts. "This book," writes Mr. Cochrane in an interesting Preface, "is an attempt to humanise Elementary Physics without popularising it." We are of opinion that in this task the author has achieved very considerable success. Theory has been given the main prominence. Experiments have not been described unless to elucidate principles. References to the makers of scientific history are frequent, and are reinforced by a number of interesting plates which include portraits of Newton, Pascal, Boyle, Galileo, and Joseph Black. The pupil's own experience is brought into connexion with physical principles as often as possible. Part 1, which might have been called Mechanics instead of Hydrostatics since it includes chapters on volume, weight, and density (not to mention surveying), occupies about two-thirds of the book, the remainder being devoted to what is certainly a "readable" account of the elementary principles of heat.

*Ions, Electrons, and Ionising Radiations.* By Dr. J. A. Crowther. Third Edition. Pp. xii+292+ii pls. (London: Edward Arnold and Co., 1922.) 12s. 6d. net.

THE first edition of Dr. Crowther's useful manual has already received notice in these columns (August 12 1920, p. 740). The fact that a third edition has been called for so soon is sufficient evidence that the book has been appreciated. The material has been thoroughly revised and the various tables of constants brought into accord with the best data obtainable. Siegbahn's work on X-ray spectra and Aston's work on positive rays receive notice, and an account is given of Sir Ernest Rutherford's recent work on the problems of atomic structure and of Bohr's theory. We have no hesitation in recommending this volume to readers desiring a systematic account of the latest developments in physics.



### Letters to the Editor.

*The Editor does not hold himself responsible for opinions expressed by his correspondents. Neither can he undertake to return, or to correspond with the writers of, rejected manuscripts intended for this or any other part of NATURE. No notice is taken of anonymous communications.]*

#### The British Association.

THE Association is to consider whether it will once more adventure into the outer regions of the Empire. That such a venture is desirable I am satisfied and so stated most definitely in the lecture I gave in 1915, at the Royal Institution, on our Australian excursion. In the interest of the younger scientific generation and of our Empire, it is of the utmost importance that we should roam over the world and discover its amenities—but the effort must be wholehearted, whenever it be made. The one failure of our Australian expedition was the insufficient support of the younger men.

It is a question whether, at the present time, when the cost of travel is so high, it will be desirable to attempt a new expedition—the chance that it will be well supported by the young men is not great. The Society of Chemical Industry could carry only a very small party last year to Canada. Therefore, the choice of a region that shall not be too distant is desirable, if the decision be to travel.

Properly speaking, the Association should go further westward, to British Columbia, north of the C.P.R., to visualise its potentialities and gain some idea of its conditions. To recommence the cycle at a middle point such as Toronto seems undesirable, at present. Montreal is the natural and would be the proper point of rededparture and discovery. It has also the advantage that it is the centre of the only region on the American continent where freedom still prevails and men are thought to be capable of taking care of themselves. It is the duty of science to protest and erect some barrier against the advancing wave of spurious puritanism which so affects Americans and now so threatens the freedom of mankind. The recent all but successful attempt to ban Darwinism in every shape and form is sufficient proof of what may happen.

HENRY E. ARMSTRONG.

#### Bohr and Langmuir Atoms.

CHEMISTS feel a difficulty in explaining molecular combination in terms of electrical attraction between the apparently revolving electrons which seem to compose the peripheral parts of an atom; and they naturally prefer a more static arrangement. Indeed, it is not easy to explain the stability of molecules in terms of any kind of purely electrical attraction between the atoms composing them: and yet, ever since Faraday, there has been an instinctive feeling that electrical attraction and chemical affinity are one and the same.

The facts of spectroscopy seem to insist on a system of revolving electric charges, while the facts of chemical combination seem to demand forces which can be treated statically; so it has been suggested that internal electrons are responsible for the radiation, while external electrons control the chemical forces. But the stability of chemical compounds can scarcely depend on loosely held external electrons, which, moreover, ought to be revolving just as much though not so fast as the inner ones.

May not a reconciliation be found by abandoning the idea of electrical attraction between atoms as the

major chemical force, and substituting for it the interlacement of the magnetic fields which inevitably accompany rapidly revolving electric charges. The orbital motion of the electrons responsible for chemical affinity, so far from constituting a difficulty, gives us a clue; for in every magnet electrons are rapidly revolving, and yet magnetic force is static. The clinging together of nails or needles near a magnet is all due to revolving electrons. Working with magnetised steel spheres, tetrahedra, and other shapes, some one with the ingenuity of Dr. Langmuir or Prof. Bragg might succeed in building up structures or models of adequate chemical significance.

The difficulty about substituting a magnetic field for an electric one, as accounting for the facts of chemical affinity, is no doubt the double polarity. But, on the other hand, this inevitable feature gives greater scope as well as greater complexity, and may ultimately be found to be an advantage; in fact, I am beginning to think that the constitution of bodies cannot be explained without it. The phenomena which long ago suggested "normal- and contra-valence" would fall into line. The stability of chemical combination would be all that could be desired, and the electrons in each atom would be peacefully engaged in giving their spectroscopic evidence (so well interpreted by the genius of Prof. Bohr), unharassed in their movements and perturbations by having to associate themselves with any electric field other than that of their own nucleus. Their magnetic linkages would be a sort of unconscious extra.

The undoubted phenomenon of ionisation would have to be developed independently, along with other known facts about gross positive and negative electric charges, but in the formation of stable chemical molecules we should not have to appeal to ionic charge. Moreover, certain molecular groupings, held together by magnetic forces, might be found readily susceptible to ionisation, especially when subject to bombardment, or when packed close together in a liquid.

I do not suppose that magnetic attraction as the equivalent of chemical affinity is any new idea, but I suggest that it has been inadequately developed, and that it seems capable of effecting a reconciliation between the extraordinarily ingenious schemes—apparently opposed, and yet both containing elements of truth—of which the names at the head of this letter may be regarded as principal types.

OLIVER LODGE.

#### The Acoustics of Enclosed Spaces.

SINCE writing the letter published in NATURE of August 19, p. 247, my attention has been directed to a paper on "Sound Proof Partitions" by Prof. R. F. Watson (University of Illinois Bulletin for March 1922). The paper contains a valuable experimental investigation on one aspect of the subject, but much remains to be done.

I take this opportunity of correcting an error which seriously affects the numerical results I gave for the sound transmitted through walls. In applying the optical equations, I forgot for the moment that the intensity of reflection in the case of sound does not only depend on the refractive index but also on the relative densities of the two bodies concerned. Even if the refractive indices were equal, so that the sound would proceed in the same direction, there would still be a powerful reflection if the densities were very unequal. In the equation I gave,  $1-\mu^2$  should be replaced by  $a-\mu^2a^{-1}$ , where  $a$  is the ratio of the densities. When sound passes from air to a solid body the second term is in general negligible, and

the transmitted intensity depends almost entirely on the ratio of the densities. If we take the case of a partition of wood having a density half that of water, calculation then shows that at normal incidence about 4 per cent. of the sound is transmitted if the thickness be 1 cm. Reducing the thickness to 2 mm., the intensity of the transmitted sound increases to 50 per cent., and rises to 80 per cent. if the thickness is only 1 mm.

What I desired to emphasise in my previous letter is that the diminution in the sound transmitted with increasing thickness is not necessarily due to any absorption, but is explained by the effect of the reflection at the second surface which, when the thickness is small compared with the wave-length, neutralises the reflection at the first surface. This does not appear to be sufficiently appreciated, and some of the conclusions drawn in Prof. Watson's paper require correction accordingly. The effect of the second surface is also of importance when total reflection ought to take place according to the usual formulæ at the first surface. With a thickness less than a wave-length, part of the sound is transmitted. This case has been treated by Lord Rayleigh ("Collected Works," vol. vi. p. 71).

ARTHUR SCHUSTER.

### The Annelids of Iceland and the Faroes.

This is a subject about which very little has hitherto been known. In discussing the part which white ants play in the economy of nature Prof. Henry Drummond compared them with earthworms. He referred to Darwin, and said that in "Vegetable Mould" a reference was made to the existence of earthworms in Iceland. I cannot find any such allusion. It is true that a few worms have been recorded for Iceland and one for the Faroes. I am fortunately in the position to add somewhat to our knowledge. My son, Dr. J. Newton Friend, having recently returned from an expedition in those islands, I have had the privilege of examining his collection of annelids. The following are the results:

The common earthworm (*Lumbricus terrestris*, L.) flourishes in Iceland. I examined twenty-three specimens, twenty of which were perfectly adult. Not one of them differed in any particular from the type as found in England. I hoped to find spermatophores, but in this matter disappointment was experienced. The specimens were collected near Reikjavik at the beginning of August, and were just in the right condition for laying their cocoons.

The red earthworm (*L. rubellus*, Hoffm.) was also found. Though adult it was smaller than our English specimens usually are, and the dorsal surface was of a darker brown colour. I have often found similar specimens, however, in the British Isles, so that they are in no sense to be looked upon as a variety.

The purple worm (*L. purpureus*, Eisen=*L. castaneus*, Sav.) has already been recorded, alike for Iceland and the Faroes. Thus each of the three common species of European *Lumbrici* is now known to be a denizen of Iceland. To these may be added two species of the genus *Dendrobaena*. One of these (*D. rubida*, Sav.) is best known by the variety usually named the gilt-tail, a denizen of ripe manure and decaying leaves. The other (*D. octoedra*, Sav.), although widely distributed geographically, is not a common species in Great Britain. Up till the present, then, five species only of the *Lumbricidae* have been recorded.

The shores of Iceland, if they could be worked as Claparede worked the Hebrides, would doubtless yield a variety of forms, especially the red-blooded pot-worms or pachydriliids. None of these, so far

as I am aware, has been up till the present placed on record, but *Citellio arenarius*, O. F. M., well known on our English coasts, is reported for the coasts of Iceland.

I can find no records for the Faroes except the purple worm already noted. It is, therefore, with peculiar pleasure that I am able to add two new members to the list. These are both enchytraeids, and were collected in peaty earth near a stream some two miles inland from Thorshaven. One of these was a pachydrilid (*Lumbricillus lineatus*, O. F. M.). I have written fully on the synonymy in the *Irish Naturalist*, and my conclusions are supported by the more recent investigations of the American helminthologist, Welch.

The other enchytraeid is of the white-blooded kind (*Mesenchytraeus oligosetosus*, Friend). It was found some time ago among gleanings made in Jersey, and described by me in the *Zoologist*. I have more recently found a striking variety of this worm, or an allied species, near Birmingham. The Faroes material agreed with the Jersey. The worm is about a third of an inch in length, and belongs to the group which has enlarged setae on the segments which contain the spermathecae. It may also be noted that I found one of the commoner opalines parasitic in the Faroese enchytraeids. Our list therefore stands thus: *Mesenchytraeus oligosetosus*, Faroe Is.; *Lumbricillus lineatus*, Faroes; *Citellio arenarius*, Iceland; *Dendrobaena rubida*, Iceland; *Dendrobaena octoedra*, Iceland; *Lumbricus purpureus*, Faroes and Iceland; *Lumbricus rubellus*, Iceland; *Lumbricus terrestris*, Iceland.

*Addendum* (Aug. 16).—A further investigation with pocket lens has resulted in some interesting additions to the foregoing list:

*Achaeta minima* Southern, only 1 mm. in length, but agreeing exactly in all particulars with the material from Ireland. The intestine contained peaty soil with a number of diatoms.

*Marionina* (*Chamaedrillus*) *sphagnetorum* (Vejd.).—Very slender, but true to type. White (colourless) blood. I stated my reasons in these columns some time ago for transferring this species to the genus *Chamaedrillus*.

*Dorylaimis obtusicaudatus* Bastian. A fine female nematode, about 2½ mm. long. All from the Faroes.

HILDERIC FRIEND.

Cathay, Solihull.

### On the Reality of Nerve-Energy.

THE expression "nerve-energy" is widely used both by non-technical writers and by medical and physiological authors as well.

What the former mean by it is of no particular moment; but in medical and physiological literature it should connote something quite definite, if indeed the existence of nerve-energy is admitted at all. There seems a doubt whether its existence is to be admitted in a formal sense, for although certain physiologists use the expression nerve-energy as a convenient term, the thing itself is not discussed in their text-books, nor does it find a place in the indexes.

If nerve-energy has no place in the scheme of things vital as conceived by modern physiologists, then the term ought not to be used by them just because it is occasionally a very useful one. When they do use it, it means no more than "innervation."

The subject is full of difficulties, one of which is our having to reckon with the use of the still vaguer

terms "vital energy" or "biotic energy." To narrow the problem, let us in the meantime exclude "vital" energy altogether, since, as an expression, it must include nerve-energy.

Now it is well known that one or two writers have, years ago, stated their belief in the reality of nerve-energy; of such are Sir William Hale White and Prof. Macdougall, then of Oxford, now of Harvard. Dr. Hale White in 1886 (*Lancet*, July 24) suggested the term "neurorheuma," and Macdougall in 1903 "neurine" for just the same thing as is understood by "nerve-energy." These terms were introduced to supply suitable technical terms (in place of the popular "nerve-energy") to designate a reality among the other forms of energy. Macdougall's term "neurine" has not been more readily adopted, because he associated it with a theory of inhibition which has occasioned much criticism.

Adopting for the moment Hale White's "neurorheuma," it means "flow in a nerve." But flow of what? Surely of nerve-energy. Some physiologists would not say so; they would reply—flow of nerve-impulses. Naturally, for nerve-impulses are the only things which do or can flow in nerves. Now nerve-impulses are real, and as they are the only things which flow in nerves, and nerve-energy is in nerves; then nerve-energy is but a synonym for nerve-impulses. This is exactly what Dr. White intended, for he insisted that nerve-energy was but one kind of energy amid several other kinds, heat, light, electricity, etc.

In itself nerve-energy is clearly *sui generis*, because the neurons (nerve cells and fibres) to which it is exclusively related are themselves histologically *sui generis*.

Now no one would teach that the nerve-fibres are the sources of the impulses they transmit; it is the cell-bodies which alone can be dynamogenic. The problem of the transmutation of nerve-energy into some other form of energy must in the meantime be left unattacked.

If energy there be, the cells are the only sources transmitting it to the fibres. Nerve-energy must be capable of existing both in the potential and kinetic states. Such indeed seems to be the truth, for it may be regarded as potential in the cells and kinetic in the fibres. But in the last analysis, what is this potential energy but that liberated by the metabolism of the nerve-cell, one aspect of the oxidations and reductions going on there? No physiologist would deny the reality of the existence of this fundamentally chemical energy of the neurone; but what is it if it is not nerve-energy?

Nerve-impulses (nerve-energy) being *sui generis* must make their measurement very difficult, if not impossible, except in terms of some other form of energy.

Now the most measurable thing which nerve-impulses do is to produce electric current. Why is the E.M.F. of this current not a sufficiently good measure of nerve-energy? It is sometimes assumed that we can measure the intensity of nerve-impulses by the muscular, cardiac, glandular, or other "work" which they evoke. It is true that feeble innervation will give rise to feeble muscular effort, violent to violent. But caution is necessary in drawing deductions as to the potential of the feeble and violent innervations respectively.

The feeble muscular effort may be feeble because only a few muscular fibres are excited, the strong because many; and all the while the actual E.M.F. of the nerve-impulses which excited the feeble effort may be the same as that of those which excited the violent.

The violent neural antecedent may be one that,

involving many nerve-cells in the commotion, "fires off" many muscle-fibres, while the feeble neural antecedent involves few; but the E.M.F. of the nerve-impulses in both cases may be the same. The work of Keith Lucas would lead us to this conclusion.

But all this does not affect the doctrine of the reality of nerve-energy. Nerve-energy is real although its measurement is difficult and may be impossible. We believed in the reality of animal heat, electricity, and light long before we were able to measure these by calorimeters, galvanometers, and photometers. Nerve-impulses impinging on a muscle stir it to activity or quell it to inactivity, so that they must be at least as real as the muscular energy excited or quelled respectively. Similarly nerve-impulses impinging on a nerve-cell cause it to transmute its potential nerve-energy into nerve-impulses.

Contrary to what the phrase would imply, Müller's "specific nerve-energy" does not throw any light on our problem. The phrase is antiquated though it embodies an important truth. What Müller had in mind was the oneness of the central result with the many forms of the peripheral stimulation.

Unless nerve-energy is a reality, neurasthenia becomes meaningless. Now although the term "neurasthenia" may not connote a definite clinical entity, yet fatigue of the nervous system both in its acute and chronic forms is a fact. From a *priori* considerations alone there must be fatigue of neural origin as of any other. The partial solution of the granules of Nissl has been asserted to be the histological counterpart or basis of fatigue of neuroplasm, but whether or not this be correct, a state of functional disability must be capable of being induced in neurones. Surely fatigue means diminution of some sort of energy: muscular fatigue is a reality, why not neural? Physiologists doubt the "fatigueability" of nerve-fibres which are but conductors, but no neurologist doubts the "fatigueability" of nerve-cells. This must, in other words, be nothing else than the diminution of the potential and quantity of the energy of neurones. All the following writers have used the expression "nerve-energy" or "nerve-force": the late Dr. Hughlings Jackson, the late Dr. Clouston, the late Sir William Osler, the late Dr. Weir Mitchell, the late Dr. Frederick Taylor; and of living writers, Sir William Bayliss, Profs. Halliburton, Howell, and Starling, and Sir Frederick Mott.

In closing let me make one or two suggestions as to how nerve-energy might be measured.

1. The increase of conductance in the skin under the influence of descending nerve-impulses as measured in the psycho-galvanic phenomenon (Waller, Golla).

Surely the magnitude of this is causally related to that of the antecedent nerve-energy liberated?

Even if this be proved to be a glandular phenomenon, we have the essentials of quantitative estimation in it.

2. Measure the E.M.F. of the current of action, say, in the cortical visual centre as the result of feeble and of strong retinal stimulation respectively.

3. Estimate the pressures or other stimuli necessary to suppress certain reflexigenous tendencies.

D. FRASER HARRIS.

Dalhousie University, Halifax, N.S.

#### Noctiluca as an Enemy of the Oyster.

IN view of the serious problems which have of late been engaging the attention of oyster culturists, involving as they do the whole future of the industry, and in connexion with which a considerable amount of scientific investigation has been carried out, the following preliminary note of observations made by

Mr. H. P. Sherwood, assistant naturalist to the Ministry, may be of interest.

Experiments in oyster culture in tanks are being carried out by the Ministry at Conway on a large scale, and have been in progress for several years. In order to throw light on the frequent failure of spat settlement under natural conditions, and the remarkable success which has almost uniformly attended the breeding experiments in the Conway tanks, special attention has been directed to the identification of enemies of the embryo oyster. Some six weeks ago large numbers of *Noctiluca miliaris* were noted in the Conway estuary, which has since contained this organism in varying quantity. Laboratory experiments were carried out, and Mr. Sherwood noted a remarkable and rapid diminution in the numbers of oyster embryos placed in aquaria in the presence of *Noctiluca*. He afterwards found that many of the *Noctiluca*s contained from one to four oyster embryos. The embryos were seen at the outset in, or in close proximity to, the peristome and mouth, later becoming scattered through the substance of the *Noctiluca*, enclosed in distinct food vacuoles.

Mr. Sherwood has made a long series of confirmatory observations, and the actual ingestion of the embryos has now been repeatedly observed, including the transference of the embryo to parts remote from the mouth.

Many exceedingly interesting observations with regard to the mechanism of ingestion, etc., have been made, but a full description would be out of place in a short communication. It may, however, be noted that the tentacle of *Noctiluca* appears to take no active part in the process of ingestion. The behaviour of the embryos suggests that their movements, and therefore power of escape, are inhibited after contact with the oral groove, either by entanglement of the cilia with mucus, or by actual paralysis induced by the action of some "stinging" mechanism. Further investigation is required, however, before any definite deductions can be drawn.

When it is considered that *Noctiluca* often occurs in the sea in enormous numbers, and that each *Noctiluca* can dispose of at least as many as four oyster embryos at a time, the importance of this observation will be apparent. I am informed that great quantities of *Noctiluca* have recently been observed in the vicinity of the oyster beds at Orford.

Another observation recently made by Mr. Sherwood, in connexion with the disappearance of oyster spat, is of interest. Not only has he found oyster embryos in the stomachs of adult oysters, but also has found the stomach of a "black sick" oyster, taken from a tank in which there was no free-swimming spat, crammed with embryos in the same stage of development as those found in the gills of the parent oyster. It would thus appear that the oyster is not only a cannibal, but also even devours its own young before extrusion.

The very interesting observations made by Dr. J. H. Orton (*NATURE*, August 5, p. 178) on the ingestion of oyster embryos by *Aurelia aurita* throw further important light on the question of failure of oyster spat fall.

R. W. DODGSON.

Ministry of Agriculture and Fisheries,  
Fisheries Experiment Station,  
Castle Bank, Conway, August 18.

#### Defoliation of Oaks.

IN view of the deplorable effect of repeated defoliation of oaks by the larvæ of *Tortrix viridana*, as noted by Mr. E. W. Swanton in *NATURE* for August 19, p. 250, it may be useful to remind planters that there

are two distinct races of British oak (*Quercus robur*, Linn.), to which some botanists have assigned specific rank as *Q. pedunculata*, Ehrh., and *Q. sessiliflora*, Salisb. The latter, known in the vernacular as the durmast oak, prevails as an indigenous growth in the western and north-western parts of Great Britain, throughout the English Lake District, and in Ireland. In eastern England and Scotland and in midland and southern England the pedunculate oak predominates, but not exclusively, for I have found that the old trees in Merevale Park, Warwickshire, survivors of the ancient Forest of Arden, are durmast, while such oaks as have been planted there are pedunculate.

The timber of these two varieties (or species) are of equal quality, the durmast being of straighter growth than the other; but there is an important and well-marked difference in their relative susceptibility to the ravages of Tortrix. The Hon. Gerald Lascelles, late deputy surveyor of the New Forest, directed my attention to this many years ago. "I have seen," he said, "a sessile oak standing out in brilliant foliage when every other oak in the wood around was as bare of leaf as in winter."

Subsequent careful observation in all parts of the country has fully confirmed Mr. Lascelles's statement. Unfortunately, the durmast forms and ripens acorns far less frequently than the pedunculate oak; hence the difficulty of obtaining durmast seedlings and plants from nurserymen, and the vast preponderance of the pedunculate oak in British and Irish plantations.

HERBERT MAXWELL.

Monreith, Whauphill,  
Wigtownshire, N.B.

#### Black Coral.

PROF. HICKSON, in his interesting article on Black Coral (*NATURE*, August 12, p. 217), alludes to the remains of Noah's Ark as quoted by Josephus from Berosus and others. It is said in Josephus (*loc. cit.*) that "the remains of the timber were a great while preserved." There is in the Monastery at Etchmiadzin a small piece of Noah's Ark carefully framed. It was given by an angel to a monk named James, who had wandered on Ararat in search of it for seven years (see J. B. Telfer, "The Crimea, etc.," 1876, p. 250). So far as I could see, when I examined it in 1898, it was neither wood nor fossil wood, but asbestos. This does not render improbable the occurrence of bitumen in the neighbourhood, but why does Prof. Hickson assume that the amulets were bracelets? In default of evidence that Noah utilised the Ark for dredging, there does not seem any reason to connect him with black coral.

F. A. BATHER.

#### Metallic Coloration of Chrysalids.

IN *NATURE* of November 3, 1921 (vol. 108, p. 302), a letter of mine appeared on the "Metallic Coloration of Chrysalids." During the present year I have had the opportunity of observing some very fine examples of the chrysalids of *R. ulica*, in which the gilding extended over the whole surface. It may be of interest, as bearing on the origin of the colour, to note that when the gilding was very gently scraped, the gold first turned to green and then to blue. In the course of a few days the scraped area assumed the same appearance as the whole chrysalid does after the butterfly has emerged, namely, a yellowish white.

A. MALLOCK.

9 Baring Crescent, Exeter, Aug. 24.

## The British Association at Hull.

THE British Association meetings are now in progress, and notwithstanding a slight difficulty which threatened to arise in obtaining rooms for the unusual influx of visitors, this has been removed and things are running smoothly. The Local Committee has endeavoured to improve the appearance of the city as much as possible by elaborate signposts, and metal signs on the electric standards, indicating the positions of the various meeting rooms and sectional lecture halls. Thus the usual appearance of a town visited by the British Association being transformed into a bill-posting station, has been avoided. Similarly, in the Reception Room and in other places, are gaily coloured artistic banners and signs in profusion, in addition to which the Parks Committee has made the rooms gay with plants and blooms.

Various corporations and public bodies in the east of Yorkshire have risen to the occasion, and, with the co-operation of the North-Eastern Railway Company, an elaborate system of special trains has been arranged to convey the members to different parts of this attractive county.

The Corporation of Scarborough is entertaining four hundred members; the Yorkshire Philosophical Society is entertaining the same number of members in the York Museum, where an official welcome will be given by the Lord Mayor; the Corporation of Harrogate is also entertaining four hundred members; Bridlington is entertaining 250, and Beverley 100. These are in addition to arrangements made in Hull itself, which include a river trip to Spurn Point in the s.s. *Brocksby*, kindly lent by the Great Central Railway Company, on which occasion the members will be entertained by the Local Committee.

There is also a garden party in Hymers College grounds (the old Botanical Gardens), where the members will be entertained by the Hull Literary and Philosophical Society, the Local Committee, and the Governors of the College.

Various firms in Hull and district (Messrs. Reckitt and Sons, the Humber Portland Cement Company, Earle's Cement Company, The British Oil and Cake Mills, Needler's Confectionery Works, the Olympia Oil Mill, Selby, and the Hull Fishing Vessel Owners' Association) are showing parties round their respective places and providing refreshment, etc.

On account of the wealth of suitable lecture and committee rooms, the work of the various sections is running smoothly, and the new Guildhall with its fine reception room, banqueting hall, etc., makes admirable headquarters, while the reception room is in easy access of the various offices placed at the disposal of the general and local officers of the association.

An experiment has been tried in the provision of an artistic numbered badge for each member, for the purpose of identification, and also for admission to the various functions of the association in place of, or in addition to, the familiar membership ticket, which, like many innovations for the Hull meeting, has been made a convenient size.

The Hull Tramways Committee has granted free tram-rides to the wearers of badges, to the great convenience of the visitors.

T. S.

## REPORT OF THE COUNCIL.

A number of important matters is referred to in the report of the council presented to the meeting of the general committee on September 6. Sir Ernest Rutherford was nominated by the council as president of the Association for the meeting to be held at Liverpool next year.

During the year covered by the report, the Association received from Sir Charles Parsons the generous gift of 10,000l. War Stock for general purposes and also a legacy of 450l. from the late Mr. T. W. Backhouse. A very welcome gift was one of 75l. from Mrs. Sidney Brown to form "the John Perry's Guest Fund" for use by the general treasurer in case of emergency connected with guests of the Association. There is frequent need for financial help such as a fund of this kind may supply, and it is to be hoped that other benefactors will be forthcoming to increase the modest amount now available for this purpose. Certain it is that no more appropriate memorial to the late treasurer of the Association, Prof. John Perry, could be established than such a fund would afford. On account of the expanding activities of the Association, professional men who are not members are often invited to give addresses or read papers to one or other of the sections, but under present conditions sectional secretaries have no power to pay even out-of-pocket expenses to such men or offer hospitality to them. The least the Association should do in such cases is to pay railway fares and entertain the special visitors as guests.

Provision of a similar kind is made by the establishment of the "British Association Exhibitions" now offered to students not above the standing of B.Sc., nominated by the senate of each of twenty universities and university colleges, and covering the railway fares of such students and their membership if not already regular members. The Local Executive Committee at Hull has kindly supplemented this aid by an offer of financial support and hospitality for such nominees. What is wanted now is to give power to each organising committee of the sections to offer like facilities to two or three leading workers in particular fields to attend meetings for the purpose of expressing their views on aspects of science seen more distinctly from outside the scientific world than within it.

The council has made some important recommendations with regard to the Conference of Delegates and the Corresponding Societies Committee. It has been agreed that the conference at Hull should consider, in the first place, what steps should be taken to induce local societies to group themselves round local (*i.e.* district) sub-centres for the interchange of information and for the more economical publication of the results of research.

The Corresponding Societies Committee is to prepare a general survey of local scientific societies, including information as to existing federations and local unions.

Mr. W. Whitaker has been nominated as president of the Conference at the Hull Meeting.

The following new members of council are nominated: Rt. Hon. Lord Bledisloe, Dr. W. E. Hoyle, and Mr. A. G. Tansley, leaving two vacancies to be filled by the general committee without nomination by the council.

Some Aspects of Animal Mechanism.<sup>1</sup>

By Sir C. S. SHERRINGTON, G.B.E., Sc.D., D.Sc., LL.D., Pres.R.S., President of the Association.

IT is sometimes said that science lives too much in itself, but once a year it tries to remove that reproach. The British Association meeting is that annual occasion, with its opportunity of talking in wider gatherings about scientific questions and findings. Often the answers are tentative. Commonly questions most difficult are those that can be quite briefly put. Thus, "Is the living organism a machine?" "Is life the running of a mechanism?" The answer cannot certainly be as short as the question. But let us, in the hour before us, examine some of the points it raises.

Of course for us the problem is not the "why" of the living organism but the "how" of its working. If we put before ourselves some aspects of this working we may judge some at least of the contents of the question. It might be thought that the problem is presented at its simplest in the simplest forms of life. Yet it is in certain aspects more seizable in complex animals than it is in simpler forms.

Our own body is full of exquisite mechanism. Many exemplifications could be chosen. There is the mechanism by which the general complex internal medium, the blood, is kept relatively constant in its chemical reaction, despite the variety of the food replenishing it and the fluctuating draft from and input into it from various organs and tissues. In this mechanism the kidney cells and the lung cells form two of the main sub-mechanisms. One part of the latter is the delicate mechanism linking the condition of the air at the bottom of the lungs with that particular part of the nervous system which manages the ventilation of the lungs. On that ventilation depends the proper respiratory condition of the blood. The nervous centre which manages the rhythmic breathing of the chest is so responsive to the respiratory state of the blood supplied to itself that, as shown by Drs. Haldane and Priestley some years ago, the very slightest increase in the partial pressure of carbon dioxide at the bottom of the lungs at once suitably increases the ventilation of the chest. Dovetailed in with this mechanism is yet another working for adjustment in the same direction. As the lung is stretched by each inbreath the respiratory condition of the nervous centre, already attuned to the respiratory quality of the air in the lungs, sets the degree to which inspiration shall fill them ere there ensue the opposite movement of outbreath. All this regulation, although the nervous system takes part in it, is a mechanism outside our consciousness. Part of it is operated chemically; part of it is reflex reaction to a stimulus of mechanical kind, though as such unperceived. The example taken has been nervous mechanism. If, in the short time at our disposal, we confine our examples to the nervous system, we shall have the advantage that in one respect that system presents our problem possibly at its fullest.

To turn therefore to another example, mainly nervous. Muscles execute our movements; they also maintain our postures. This postural action of muscles is produced by nerve-centres which form a system more or less their own. One posture of great importance thus

maintained is that of standing, the erect posture. This involves due co-operation of many separate muscles in many parts. Even in the absence of those portions of the brain to which consciousness is adjunct, the lower nerve-centres successfully bring about and maintain the co-operation of muscles which results in the erect posture; for example, the animal in this condition, if set on its feet, stands. It stands reflexly; more than that, it adjusts its standing posture to required conditions. If the pose of one of the limbs be shifted a compensatory shift in the other limbs is induced, so that stability is retained. A turn of the creature's neck sidewise and the body and limbs, of themselves, take up a fresh attitude appropriate to the side-turned head. Each particular pose of the neck telegraphs off to the limbs and body a particular posture required from them, and that posture is then maintained so long as the neck posture is maintained. Stoop the creature's neck and the forelimbs bend down as if to seek something on the floor. Tilt the muzzle upward and the forelimbs straighten and the hind limbs crouch as if to look at something on a shelf. Purely reflex mechanism provides all kinds of ordinary postures.

More reflex action provides these harmonies of posture. The nerve-centres evoke for this purpose in the required muscles a mild, steady contraction, with tension largely independent of the muscle length and little susceptible to fatigue. Nerve-fibres run from muscle to nerve-centre, and by these each change in tension or length of the muscle is reported to the activating nerve-centre. They say "tension rising, you must slacken," or conversely. There are also organs the stimulation of which changes with any change of their relation to the line of gravity. Thus, a pair of tiny water-filled bags is set one in each side of the skull and in each is a patch of cells endowed with a special nerve. Attached to hairlets of these cells is a tiny crystalline stone the pressure of which acts as a stimulus through them to the nerve. The nerve of each gravity-bag connects, through chains of nerve-centres, with the muscles of all the limbs and of one side of the neck. In the ordinary erect posture of the head, the stimulation by the two bags right and left is equal, because the two gravity-stones then lie symmetrically. The result, then, is a symmetrical muscular effect on the two sides of the body, namely, the normal erect posture. But the right and left bags are mirror pictures of each other. If the head incline to one side, the resulting slip, microscopic though it be, of the two stones on their nerve-patches makes the stimulation unequal. From that slip there results exactly the right unsymmetrical action of the muscles to give the unsymmetrical pose of limbs and neck required for stability. That is the mechanism dealing with limbs and trunk and neck. An additional one postures the head itself on the neck. A second pair of tiny gravity-bags, in which the stones hang rather than press, are utilised. These, when any cause inclining the head has passed, bring the head back at once to the normal symmetry of the erect posture. These same bags also manage the posturing of the eyes. The eye contributes to our orientation in space; for example, to perception of the vertical. For this the eyeball, that

<sup>1</sup> Presidential Address delivered at the Hull Meeting of the British Association on Sept. 6.

is the retina, has to be postured normally, and the pair of little gravity-bags in the skull, which serve to restore the head posture, act also on the eyeball muscles. Whichever way the head turns, slopes, or is tilted, they adjust the eyeball's posture compensatingly, so that the retina still looks out upon its world from an approximately normal posture, retaining its old verticals and horizontals. As the head twists to the right the eyeball's visual axis untwists from the right. These reactions of head, eyes and body unconsciously take place when a bird wheels or slants in flight or a pilot stalls or banks his aeroplane; and all this works itself involuntarily as a pure mechanism.

True, in such a glimpse of mechanism what we see mainly is how the machinery starts and what finally comes out of it; of the intermediate elements of the process we know less. Each insight into mechanism reveals more mechanism still to know. Thus, scarcely was the animal's energy balance in its bearing upon food intake shown comfortably to conform with thermodynamics than came evidence of the so-called "vitamins"—evidence showing an unsuspected influence on nutrition by elements of diet taken in quantities so small as to make their mere calorie value quite negligible; thus, for the growing rat, to quote Prof. Harden, a quantity of vitamin A of the order of  $\frac{1}{30000}$  milligram a day has potent effect. Again, as regards sex determination, the valued discovery of a visible distinction between the nuclear threads of male and female brings the further complexity that, in such cases, sex extends throughout the whole body to every dividing cell. Again, the association of hereditary unit-factors, such as body colour or shape of wing, to visible details in the segmenting nucleus seemed to simplify by epitomising. But further insight tends to trace the inherited unit character not to the chromosome itself, but to balance of action between the chromosome group. As with the atom in this heroic age of physicists, the elementary unit once assumed simple proves, under further analysis, to be itself complex. Analysis opens a vista of further analysis required. Knowledge of muscle contraction has, from the work of Fletcher and Hopkins on to Hill, Hartree, Meyerhof, and others, advanced recently more than in many decades heretofore. The engineer would find it difficult to make a motive machine out of white of egg, some dissolved salts, and thin membrane. Yet this is practically what Nature has done in muscle, and obtained a machine of high mechanical efficiency. Perhaps human ingenuity can learn from it. One feature in the device is alternate development and removal of acidity. The cycle of contraction and relaxation is traced to the production of lactic acid from glycogen and its neutralisation chiefly by alkaline proteins; and physically to an admirably direct transition from chemical to mechanical effect. What new steps of mechanism all this now opens!

But knowledge, while making for complexity, makes also for simplification. There seems promise of simplification of the mechanism of reflex action. Reflex action with surprising nicety calls into play just the appropriate muscles, and adjusts them in time and in the suitable grading of their strength of pull. The moderating as well as the driving of muscles is involved. Also the muscles have to pass from the behest of one

stimulus to that of another, even though the former stimulus still persist. For these gradings, coadjustments, restraints, and shifts, various separate kinds of mechanism were assumed to exist in the nerve-centres, although of the nature of such mechanisms little could be said. Their processes were regarded as peculiar to the nerve-centres and different from anything that the simple fibres of nerve-trunks outside the centres can produce. We owe to Lucas and Adrian the demonstration that, without any nerve-centre whatever, an excised nerve-trunk with its muscle attached can be brought to yield, besides conduction of nerve impulses, the grading of them. That is remarkable, because the impulse is not gradable by grading the strength of the stimulus. The energy of the impulse comes not from the stimulus, but from the fibre itself. But Lucas and Adrian have shown, however, that it is gradable in another way. Though the nerve impulse is a very brief affair—it lasts about  $\frac{1}{1000000}$  second at any one point of the nerve—it leaves behind it in the nerve-fibre a short phase during which the fibre cannot develop a second impulse. Then follows rapid but gradual recovery of the strength of impulse obtainable from the fibre. That recovery may swing past normal to super-normal before returning finally to the old resting state. Hence, by appropriately timing the arrival of a second impulse after a first, that second impulse may be extinguished, reduced, increased or transmitted without alteration. This property of grading impulses promises a complete key to reflex action if taken along with one other. The nervous system, including its centres, consists of nothing but chains of cells and fibres. In these chains the junctions of the links appear to be points across which a large impulse can pass, though a weak one will fail. At these points the grading of impulses by the interference process just outlined can lead, therefore, to narrowing or widening their further distribution, much as in a railway system the traffic can be blocked or forwarded, condensed or scattered. Thus the distribution and quantity of the muscular effect can be regulated and shifted not only from one muscle to another, but in one and the same muscle it can be graded by adding to or subtracting from the number of fibres activated within that muscle. As pointed out by Prof. Alexander Forbes, it may be, therefore, that the nerve impulse is the one and only reaction throughout the whole nervous system, central and peripheral,—trains of impulses colliding and over-running as they travel along the conductive network. In this may lie the secret of the co-ordination of reflexes. The nerve-centre seems nothing more than a meeting-place of nerve-fibres, its properties but those of impulses in combination. Fuller knowledge of the mechanism of the nervous impulse, many of the physical properties of which are now known, a reaction which can be studied in the simplest units of the nervous system, thus leads to a view of nervous function throughout the system much simpler than formerly obtained.

Yet for some aspects of nervous mechanism the nerve impulse offers little or no clue. The fibres of nerve-trunks are, perhaps, of all nerve-structures those that are best known. They constitute, for example, the motor nerves of muscle and the sensory nerves of the skin. They establish their ties with muscle and skin during embryonic life and maintain them practi-

cally unaltered throughout the individual's existence, growing no further. If severed, say, by a wound, they die for their whole length between the point of severance and the muscle or skin they go to. Then at once the cut ends of the nerve-fibres start re-growing from the point of severance, although for years they have given no sign of growth. The fibre, so to say, tries to grow out to reach to its old far-distant muscle. There are difficulties in its way. A multitude of non-nervous repair cells growing in the wound spin scar tissue across the new fibre's path. Between these alien cells the new nerve-fibre threads a tortuous way, avoiding and never joining any of them. This obstruction it may take many days to traverse. Then it reaches a region where the sheath-cells of the old dead nerve-fibres lie altered beyond ordinary recognition. But the growing fibre recognises them. It joins them and, tunnelling through endless chains of them, arrives finally, after weeks or months, at the wasted muscle-fibres which seem to have been its goal, for it connects with them at once. It pierces their covering membranes and reforms with their substance junctions of characteristic pattern resembling the original that had died weeks or months before. Then its growth ceases, abruptly, as it began, and the wasted muscle recovers and the lost function is restored.

Can we trace the causes of this beneficent yet so unaccountable reaction? How is it that severance can start the nerve re-growing. How does the nerve-fibre find its lost muscle microscopically miles away? What is the mechanism that drives and guides it? Is it a chemotaxis like that of the antherozoid in the botanical experiment drawn towards the focus of the dissolved malic acid? If so, there must be a marvellously arranged play of intricate sequences of chemically attractive and repellent substances dissolved suitably point to point along the tissue. It has recently been stated that the nerve-fibre growing from a nerve-cell in a nutrient field of graded electrical potential grows strictly by the axis of the gradient. Some argue for the existence of such potential gradients in the growing organism. Certainly nerve regeneration seems a return to the original phase of growth, and pieces of adult tissue removed from the body to artificial nutrient media in the laboratory take on vigorous growth. Prof. Champy describes how epithelium that in the body is not growing, when thus removed starts growing. If freed from all fibrous tissue, its cells not only germinate, but, as they do so, lose their adult specialisation. In nerve regeneration the nerve-sheath cells, and to some extent the muscle-cells which have lost their nerve-fibre, lose likewise their specialised form, and regain it only after touch with the nerve-cell has been re-established. So similarly epithelium and its connective tissue cultivated outside the body together both grow and both retain their specialisation. The evidence seems to show that the mutual touch between the several cells of the body is decisive of much in their individual shaping and destiny. The severance of a nerve-fibre is an instance of the dislocation of such a touch. It recalls well-known experiments on the segmenting egg. Destruction of one of the two halves produced by the first segmentation of the egg results in a whole embryo from the remaining half-egg; but if the two blastomeres, though ligated, be left side by side, each then produces

a half-embryo. Each half-egg *can* yield a whole embryo, but is restrained by the presence of the twin cell to yielding but a half embryo. The nerve severance seems to break a mutual connexion which restrained cell growth and maintained cell differentiation.

It may be said that the nerve-sheath cells degrade because the absence of transmission of nerve impulses leaves their fibre functionless. But they do not degrade in the central nerve-piece, although impulses no longer pass along the afferent fibres. This mechanism of reconstruction seems strangely detached from any direct performance of function. The sprouting nerve-fibres of a motor nerve with impulses for muscular contraction can by misadventure take their way to denervated skin instead of muscle. They find the skin-cells the nerve-fibres of which have been lost, and on these they bud out twigs, as true sensory fibres would do. Then, seemingly satisfied by so doing, they desist from further growth. The sense-cells, too, after this misunion, regain their normal features. But this joining of motor nerve-fibre with sense-cell is functionless, and must be so because the directions of functional conduction of the two are incompatible. Similarly a regenerating skin-nerve led down to muscle makes its union with muscle instead of skin, though the union is a functional misfit, and cannot subservise function. Marvellous though nerve regeneration be its mechanism seems blind. Its vehemence is just as great after amputation, when the parts lost can of course never be re-reached. Its blindness is sadly evident in the suffering caused by the useless nerve-sprouts entangled in the scar of a healing or healed limb-stump.

There is a great difference, however, between the growth of such regeneration and the growth impulse in pieces of tissue isolated from the body and grown in media outside. With pure cultures, in the latter case, Prof. Champy says the growth recalls in several features that of malignant tumours, for example, multiplication of cells unaccompanied by formation of a specialised adult tissue. A piece of kidney cultivated outside the body de-differentiates, to use his term, into a growing mass unorganised for renal function. But with connective-tissue cells added even breast-cancer epithelium will in cultivation grow in glandular form. New ground is being broken in the experimental control of tissue growth. The report of the Imperial Cancer Research Fund mentions that in cultivation outside the body malignant cells present a difficulty that normal cells do not. To the malignant cells the nutrient soil has to be renewed more frequently, because they seem rapidly to make the soil in which they grow poisonous to themselves, though not to normal cells. The following of all clues of difference between the mechanism of malignant growth and of normal is fraught with importance which may be practical as well as theoretical.

The regenerating nerve rebuilds to a plan that spells for future function, but throughout all its steps prior to the time when it actually reaches the muscle or skin, no actual performance of nerve-function can take place. What is constructed is functionally useless until the whole is complete. So similarly with much of the construction of the embryo in the womb for purposes of a different life after emergence from the womb; of the lung for air-breathing after birth; of the reflex contraction in the foetal child of the eyelids to protect the



eye long before the two eyelids have been separated, let alone ere hurt or even light can reach it; of the butterfly's wing within the chrysalis for future flight. The nervous system in its repair, as in its original growth, shows us a mechanism working through phases of non-functioning preparation in order to forestall and meet a future function. It is a mechanism against the seeming prescience of which is to be set its fallibility and its limitations. The "how" of its working is at present chiefly traceable to us in the steps of its results rather than in comprehension of its intimate reactions; as to its mechanism, perhaps the point of chief import for us here is that those who are closest students of it still regard it as a mechanism. If "to know" be "to know the causes" we must confess to want of knowledge of how its mechanism is contrived.

If we knew the whole "how" of the production of the body from egg to adult, and if we admit that every item of its organic machinery runs on physical and chemical rules as completely as do inorganic systems, will the living animal present no other problematical aspect? The dog, our household friend—do we exhaust its aspects if in assessing its sum-total we omit its mind? A merely reflex pet would give little pleasure even to the fondest of us. True, our acquaintance with other mind than our own can only be by inference. We may even hold that mind as an object of study does not come under the rubric of Natural Science at all. But this Association has its Section of Psychology, and my theme of to-night was chosen partly at the suggestion of a late member of it, Dr. Rivers, the loss of whom we all deplore. As a biologist he viewed mind as a biological factor. Keeping mind and body apart for certain analytic purposes must not allow us to forget their being set together when we assess as a whole even a single animal life.

Taking as manifestations of mind those ordinarily received as such, mind does not seem to attach to life, however complex, where there is no nervous system, nor even where that system, though present, is little developed. Mind becomes more recognisable the more the nerve-system is developed; hence the difficulty of the twilit emergence of mind from no mind, which is repeated even in the individual life history. In the nervous system there is what is termed localisation of function—relegation of different works to the system's different parts. This localisation shows mentality, in the usual acceptation of that term, not distributed broadcast throughout the nervous system, but restricted to certain portions of it; for example, among vertebrates to what is called the forebrain, and in higher vertebrates to the relatively newer parts of that forebrain. Its chief, perhaps its sole, seat is a comparatively modern nervous structure superposed on the non-mental and more ancient other nervous parts. The so-to-say mental portion of the system is placed so that its commerce with the body and the external world occurs only through the archaic non-mental remainder of the system. Simple nerve impulses, their summations and interferences, seem the one uniform office of the nerve-system in its non-mental aspect. To pass from a nerve impulse to a psychical event, a sense-impression, percept, or emotion is, as it were, to step from one world to another and incommensurable one. We might expect, then, that at the places of transition from its non-mental

to its mental regions the brain would exhibit some striking change of structure. But it is not so; in the mental parts of the brain there is nothing but the same old structural elements, set end to end, suggesting the one function of the transmission and collision of nerve impulses. The structural inter-connexions are richer, but that is merely a quantitative change.

I do not want, and do not need, to stress our inability at present to deal with mental actions in terms of nervous actions, or *vice versa*. Facing the relation borne in upon us as existent between them, however, may we not gain some further appreciation of it by reminding ourselves even briefly of certain points of contact between the two? Familiar as such points are, I will mention rather than dwell upon them.

One is the so-called expression of the emotions. The mental reaction of an emotion is accompanied by a nervous discharge which is more or less characteristic for each several type of emotion, so that the emotion can be read from its bodily expression. This nervous discharge is involuntary, and can affect organs, such as the heart, which the will cannot reach. Then there is the circumstance that the peculiar ways and tricks of the nervous machinery as revealed to us in the study of mere reflex reactions repeat themselves obviously in the working of the machinery to which mental actions are adjunct. The phenomenon of fatigue is common to both, and imposes similar disabilities on both. Nervous exhaustion and mental exhaustion mingle. Then, as offset against this disability, there exists in both the amenability to habit formation, mere repetition within limits rendering a reaction easier and readier. Then, and akin to this, is the oft-remarked trend in both for a reaction to leave behind itself a trace, an engram, a memory, the reflex engram, and the mental memory.

How should inertia and momentum affect non-material reactions? Quick though nervous reactions are, there is always easily observed delay between delivery of stimulus and appearance of the nervous end effect; and there is always the character that a reaction once set in motion does not cease very promptly. Just the same order of lag and overrun, of want of dead-beat character, is met in sense-reactions. The sensation outlives the light which evoked it, and the stronger the reaction the longer the sensation persists. Similarly the reflex after-discharge persists after the stimulus is withdrawn and subsides more slowly the stronger the reaction. The times in both are of the same order. Again, a reflex act which contracts one muscle commonly relaxes another. Even so, with rise of sensation in one part of the visual field commonly occurs lapse of sensation in another. The stoppage is in both by inhibition, that is to say, active. Then again, two lights of opposite colour falling simultaneously and correspondingly on the two retinae will, according to their balance, fuse to an intermediate tint or see-saw back and forth between the one tint and the other. Similarly a muscle impelled by two reflexes, one tending to contract it, the other to relax it, will, according to the balance of the reflexes, respond steadily with an intensity which is a compromise between the two, or see-saw rhythmically from extreme to extreme of the two opposite influences.

Reflex acts commonly predispose to their opposites; thus the visual impression of one colour predisposes to

that of its opposite. Again, the *position* of the stimulated sensual point acts on the mind—hence the light seen or the pain felt is referred to some locus in the mind's space-system. Similarly the reflex machinery directs, for example, the limb it moves towards the particular spot stimulated. Such spots in the two processes, mental and non-mental, correspond.

Characteristic of the nervous machinery is its arrangement in what Hughlings Jackson called "levels," the higher levels standing to the lower not only as drivers but also as restrainers. Hence in disease underaction of one sort is accompanied by overaction of another. Thus in the arm affected by a cerebral stroke, besides loss of willed—that is higher level—power in the finger muscles, there is in other muscles involuntary overaction owing to escape of lower centres from control by the higher which have been freed. Similarly with the sensory effects; of skin sensations some are painful and some not, for example, touch. The seat of the latter is of higher level, cortical; of the former lower, sub-cortical. When cerebral disease breaks the path between the higher and the underlying level a result is impairment of touch sensation but heightening of pain sensation in the affected part. The sensation of touch, as Dr. Head says, restrains that of pain.

Thus features of nervous working resemble over and over again mental activities. Is it mere metaphor, then, when we speak of mental attitudes as well as bodily? Is it mere analogy to liken the warped attitude of the mind in a psychoneurotic sufferer to the warped attitude of the body constrained by an internal potential pain? Again, some mental events seem spontaneous; in the nervous system some impulses seem generated automatically from within.

It may be said of all these similarities of time-relation and the rest between the ways of the nervous system and such simpler ways of mind as I here venture on, that they exist because the operations of the mental part of the nervous system communicate with the exterior only through the non-mental part as gateway, and that there the features of the nerve-machinery are impressed on the mind's working. But that suggestion does not take into account the fact that the higher and more complex the mental process, the longer the time-lag, the more incident the fatigue, the more striking the memory character, and so on.

All this similarity does but render more succinct the old enigma as to the nexus between nerve impulse and mental event. In the proof that the working of the animal mechanism conforms with the first law of thermodynamics is it possible to say that psychical events are evaluated in the balance sheet drawn up? On the other hand, Mr. Barcroft and his fellow-observers in their recent physiological exploration of life on the Andes at 14,200 ft. noted that their arithmetic as well as their muscles were at a disadvantage; the low oxygen pressure militated against both. Indeed, we all know that a few minutes without oxygen, or a few more with chloroform, and the psychical and the nervous events will lapse together. The nexus between the two sets of events is strict, but for comprehension of its nature we still require, it seems, comprehension of the unsolved mystery of the "how" of life itself. A shadowy bridge between them may lie perhaps in the reflection that for the observer himself the physical

phenomena he observes are in the last resort psychical.

The practical man has to accept nervous function as a condition for mental function without concerning himself about ignorance of their connexion. We know that with structural derangement or destruction of certain parts of the brain goes mental derangement or defect, while derangement or destruction of other parts of the nervous system is not so accompanied. Decade by decade the connexion between certain mental performances and certain cerebral regions becomes more definite. Certain impairments of ideation as shown by forms of incomprehension of language or of familiar objects can help to diagnose for the surgeon that part of the brain which is being compressed by a tumour, and the tumour gone the mental disabilities pass. Similarly those who, like Prof. Elliot Smith and Sir Arthur Keith, recast the shape of the cerebrum from the cranial remains of prehistoric man, can outline for us something of his mentality from examination of the relative development of the several brain regions, using a true and scientific phrenology.

Could we look quite naively at the question of a seat for the mind within the body we might perhaps suppose it diffused there, not localised in any one particular part at all. That it is localised and that its localisation is in the nervous system—can we attach meaning to that fact? The nervous system is that bodily system the special office of which, from its earliest appearance onward throughout evolutionary history, has been more and more to weld together the body's component parts into one consolidated mechanism reacting as a unity to the changeful world about it. More than any other system it has constructed out of a collection of organs an individual of unified act and experience. It represents the acme of accomplishment of the integration of the animal organism. That it is in this system that mind, as we know it, has had its beginning, and with the progressive development of the system has developed step for step, is surely significant. So it is that the portion in this system to which mind transcendently attaches is exactly that where are carried to their highest pitch the nerve-actions which manage the individual as a whole, especially in his reactions to the external world. There, in the brain, the integrating nervous centres are themselves further compounded, inter-connected, and re-combined for unitary functions. The cortex of the forebrain is the main seat of mind. That cortex with its twin halves corresponding to the two side-halves of the body is really a single organ knitting those halves together by a still further knitting together of the nervous system itself. The animal's great integrating system is there still further integrated and this supreme integrator is the seat of all that is most clearly inferable as the animal's mind. As such it has spelt biological success to its possessors. From small beginnings it has become steadily a larger and larger feature of the nervous system, until in adult man the whole remaining portion of the system is relatively dwarfed by it. It is not without significance, perhaps, that in man this organ, the brain cortex, bifid as it is, shows unmistakable asymmetry. Man is a tool-using animal, and tools demand asymmetrical, though attentive and therefore unified, acts. A nervous focus unifying such motor function will, in regard to a laterally bipartite

organ, tend more to one half or the other and in man's cerebrum the preponderance of one-half, namely, the left, over the other may be a sign of unifying function.

It is to the psychologist that we must turn to learn in full the contribution made to the integration of the animal individual by mind. But each of us can recognise, without being a professed psychologist, one achievement in that direction which mental endowment has produced. Made up of myriads of microscopic cell-lives, individually born, feeding and breathing individually within the body, each one of us nevertheless appears to himself a single entity, a unity experiencing and acting as one individual. In a way the more far-reaching and many-sided the reactions of which a mind is capable the more need, as well as the more scope, for their consolidation to one. True, each one of us is in some sense not one self, but a multiple system of selves. Yet how closely those selves are united and integrated to one personality. Even in those extremes of so-called double personality one of their mystifying features is that the individual seems to himself at any one time wholly either this personality or that, never the two commingled. The view that regards hysteria as a mental dissociation illustrates the integrative trend of the total healthy mind. Circumstances can stress in the individual some, perhaps lower, instinctive tendency that conflicts with what may be termed his normal personality. This latter, to master the conflicting trend, can judge it in relation to his main self's general ethical ideals and duties to self and the community. Thus intellectualising it, he can destroy it or consciously subordinate it to some aim in harmony with the rest of his personality. By so doing there is gain in power of will and in personal coherence of the individual. But if the morbid situation be too strong or the mental self too weak, instead of thus assimilating the contentious element the mind may shun and, so to say, endeavour to ignore it. That way lies danger. The discordant factor escaped from the sway of the conscious mind produces stress and strain of the conscious self; hence, to use customary terminology, dissociation of the self sets in, bringing in its train those disabilities, mental or nervous or both, which characterise the sufferer from hysteria. The normal action of the mind is to make up from its components one unified personality. When we remember the manifold complexity of composition of the human individual, can we observe a greater example of solidarity of working of an organism than that presented by the human individual, intent and concentrated, as the phrase goes, upon some higher act of strenuous will? Physiologically the supreme development of the brain, psychologically the mental powers attaching thereto, seem to represent from the biological standpoint the very culmination of the integration of the animal organism.

The mental attributes of the nervous system would be, then, the coping-stone of the construction of the individual. Surveyed in their broad biological aspect, we see them carrying integration even further still. They do not stop at the individual; they proceed beyond the individual; they integrate, from individuals, communities. When we review, so far as we can judge it, the distribution of mind within the range of animal forms, we meet two peaks of its development—one in insect life, the other in the vertebrate, with its acme

finally in man. True, in the insect the type of mind is not rational but instinctive, whereas at the height of its vertebrate development reason is there as well as instinct. Yet in both one outcome seems to be the welding of individuals into societies on a scale of organisation otherwise unattained. The greatest social animal is man and the powers that make him so are mental; language, tradition, instinct for the preservation of the community, as well as for the preservation of the individual, reason actuated by emotion and sentiment, and controlling and welding egoistic and altruistic instincts into one broadly harmonious, instinctive-rational behaviour. Just as the organisation of the cell-colony into an animal individual receives its highest contribution from the nervous system, so the further combining of animal individuals into a multi-individual organism, a social community, merging the interests of the individual in the interests of the group, is due to the nervous system's crowning attributes, the mental. That this integration is still in process, still developing, is obvious from the whole course of human pre-history and history. The biological study of it is essentially psychological; it is the scope and ambit of social psychology. Not the least interesting and important form of social psychology is that relatively new one, dealing with the stresses and demands that organised industry makes upon the individual as a unit in the community of our day and with the readjustments it asks from that community.

To resume, then, we may, I think, conclude that in some of its aspects animal life presents to us mechanism the "how" of which, despite many gaps in our knowledge, is fairly explicable. Of not a few of the processes of the living body, such as muscular contraction, the circulation of the blood, the respiratory intake and output by the lungs, the nervous impulse and its journeyings, we may fairly feel, from what we know of them already, that further application of physics and chemistry will furnish a competent key. We may suppose that in the same sense as we can claim to-day that the principles of a gas-engine or an electro-motor are comprehensible, so will the bodily working in such mechanisms be understood by us, and indeed are largely so already. It may well be possible to understand the principle of a mechanism which we have not the means or skill ourselves to construct; for example, we cannot construct the atoms of a gas-engine.

Turning to other aspects of animal mechanism, such as the shaping of the animal body, the conspiring of its structural units to compass later functional ends, the predetermination of specific growth from egg to adult, the predetermined natural term of existence, these, and their intimate mechanism, we are, it seems to me, despite many brilliant inquiries and inquirers, still at a loss to understand. The steps of the results are known, but the springs of action still lie hidden. Then again, the "how" of the mind's connexion with its bodily place seems still utterly enigma. Similarity or identity in time-relations and in certain other ways between mental and nervous processes does not enlighten us as to the actual nature of the connexion existing between the two. Advance in biological science does but serve to stress further the strictness of the nexus between them.

Great differences of difficulty therefore confront our

understanding of various aspects of animal life. Yet the living creature is fundamentally a unity. In trying to make the "how" of an animal existence intelligible to our imperfect knowledge we have, for purposes of study, to separate its whole into part-aspects and part-mechanisms, but that separation is artificial. It is as a whole, a single entity, that the animal, or for that matter the plant, has finally and essentially to be envisaged. We cannot really understand one part without the other. Can we suppose a unified entity which is part mechanism and part not? One privilege open to the human intellect is to attempt to comprehend, not leaving out of account any of its properties, the "how" of the living creature as a whole. The problem is ambitious, but its importance and its reward are all the greater if we seize and attempt the full width of its

scope. In the biological synthesis of the individual it is concerned with mind. It includes examination of man himself as acting under a biological trend and process which is combining individuals into a multi-individual organisation, a social organism surely new in the history of the world. This biological trend and process is constructing a social organism the cohesion of which depends mainly on a property developed so specifically in man as to be, broadly speaking, his alone, namely, a mind actuated by instincts but instrumented with reason. Man, often Nature's rebel, as Sir Ray Lankester has luminously said, can, viewing this great supra-individual process, shape his course conformably with it even as an individual, feeling that in this case to rebel would be to sink lower rather than to continue his own evolution upward.

### Scientific Problems and Progress.

ADDRESSES OF PRESIDENTS OF SECTIONS OF THE BRITISH ASSOCIATION.

#### THE THEORY OF NUMBERS.

IN his presidential address to Section A (Mathematics and Physics), Prof. G. H. Hardy propounded a series of five problems of general interest in the theory of numbers, which are still awaiting solution.

(a) *When is a number the sum of two cubes, and what is the number of its representations?* The density of the distribution of such numbers tends to zero as the number tends to infinity, but no simple criterion by which these numbers can be recognised is known. The least number expressible in more than one way as a sum of two cubes is 1729, which is  $12^3 + 1^3$  or  $10^3 + 9^3$ . Four representations of  $19 \times 363516^3$  are known, and this is apparently the largest number of such forms which has been obtained.

(b) *Is every large number the sum of five cubes?* Two numbers, 23 and 239, require nine cubes; there are fifteen numbers requiring eight, and 121 numbers requiring seven, the largest of the latter being 8042. Six-cube numbers probably disappear before reaching 1,000,000, and possibly five-cube numbers also disappear, but in huge numbers, for four-cube numbers persist for ever.

(c) *Is  $2^{2^37} - 1$  prime?* This problem belongs to the theory of the so-called "perfect" numbers, each of which is the sum of all its divisors including unity. The number  $2^n - 1$  can be prime only when  $n$  is prime, and 137 is the least value of  $n$  for which the answer is still doubtful. Two other problems connected with the perfect numbers, for which solutions are still sought are: Can a perfect number be odd? and, are there an infinite number of perfect numbers?

(d) *Are there infinitely many primes of the form  $n^2 + 1$ ?* The general distribution of primes is, in all essentials, solved, but much remains to be done among numbers of special form. The form  $n^2 + 1$  is the simplest case of the general form  $an^2 + 2bn + c$ , and although an approximate formula, which has been well tested, has been obtained for determining the number of primes, there is no immediate prospect of an accurate proof.

(e) *Are there infinitely many prime pairs,  $p, p+2$ ?* This is a particular case of the question whether any group of primes recur indefinitely. Apparently all possible groups recur for ever with definite frequency;

and so far as the first million numbers are concerned, the proposition has been tested, but there is no rigid proof of its accuracy.

#### CHEMISTRY OF THE SUGARS.

PRINCIPAL IRVINE spent the first part of his address to Section B (Chemistry) in discussing the new responsibilities which devolve upon scientific chemists who take advantage of the facilities offered by the Department of Scientific and Industrial Research (see NATURE, July 22, p. 131).

The second section of the address was devoted to an account of how investigations on the sugars carried out in the St. Andrews' Laboratories for many years are being developed so as to include the structural problems of the polysaccharides. These compounds are shown to be composed of comparatively simple units, as indicated below.

*Cellulose.*— $\alpha$ -Cellulose gives a trimethyl derivative as the maximum substitution product, and this in turn yields on hydrolysis only 2-, 3-, 6-trimethyl glucose. The simplest formula for cellulose would thus be an anhydro-di-glucose, each hexose residue being substituted in positions 1 and 5, but, in order to accommodate the yield of cellobiose obtained from cellulose, the molecule for the latter is held to be that of a tri-(1-, 5-anhydroglucose).

*Starch.*—The methylation of starch gives a product which contains seven methyl groups for every unit of eighteen carbon atoms. These are distributed in such a manner that one glucose residue contains three methyl groups, while two such groups are present in each of the remaining glucose residues. Starch is thus based on an anhydro-trisaccharide to which a structure has been ascribed.

*Inulin.*—This polysaccharide is known to be composed entirely of  $\gamma$ -fructose residues, and each of these has now been shown to be identical in structure. It is in the meantime premature to say if inulin is derived from the simple unit  $C_6H_{10}O_5$  or from the double or triple multiple of this, but in any event the  $\gamma$ -ketose residues are symmetrically disposed.

A close structural relationship has thus been established between (a) cellulose and starch, (b) starch and lactose, (c) inulin and sucrose.

## PHYSIOGRAPHY OF THE COAL SWAMPS.

THE purport of the presidential address delivered by Prof. P. F. Kendall to Section C (Geology) was to show that coal seams are the result of growth and accumulations of peat, *in situ*, and that all the phenomena of the British coal-measures can be explained upon this hypothesis, with the necessary implication of great deltaic swamps.

The English coal-measures consist of fresh-water muds and sands with occasional intercalations of marine sediments of relatively small amount. This theory is in full accord with what is known of modern swamps and deltas. Two types of sandstones occur; one, having the form and arrangement of deltaic sandbanks, is often of wide extent, the other taking the form of meandering river-channels which may cut out an entire seam, producing a "wash out." One such example, in which 90 ft. of normal measures and large areas of coal are replaced, was mentioned.

The splitting of coal-seams is attributed in some cases to contemporary river-erosion, and in others to local sags, drowning the vegetation and interrupting coal growth. Effects of contemporary earthquakes are recognisable in many seams and districts. They take the form of "lurched" margins of wash-outs, casts of sand-fountains, sandstone dykes, "swillies," or trough-like inflexions of seams, and contemporary faults affecting lower and not upper seams. All these effects are of earlier date than the ordinary faulting of the strata.

In discussing the various types of material which constitute coal-seams, stress was laid on the distinction between coal and cannel. The explanation of "coal balls" proposed by Stopes and Watson is accepted with the corollary that the constituent plants must, in some cases, have grown in salt water.

In conclusion attention is directed to the phenomenon of cleat, that is, the system of jointing in coal, the one coal-measure phenomena for which there is no obvious modern parallel. Observation of its direction all over the world and in deposits of all ages, from Carboniferous to Pleistocene, shows an overwhelming preponderance of N.W.-S.E. in the northern hemisphere and N.E.-S.W. in the southern. This seems to be in some way related to the earth's planetary rôle, but data are not yet sufficiently complete to justify the formulation of a theory. Every morsel of coal, even a single leaf of cordaites  $\frac{1}{100}$  of an inch in thickness, exhibits a regular cleat in the specified direction. The absence of cleat in anthracite is held to explain the low ash percentage. Jointing, comparable to cleat and agreeing in direction, occurs in some limestones.

## THE PROGRESSION OF LIFE IN THE SEA.

In his address to Section D (Zoology) the president, Dr. E. J. Allen, first discussed the theory that life in the world had its origin in the sea, referring to recent work by Baly on the formation of formaldehyde and sugars by the action of light of short wave-length on carbonic acid and water, and to the views expressed by Church on the building up of an autotrophic flagellate from the ions present in sea-water. An account was given of work on the culture of marine diatoms, showing the necessity for the presence of traces of organic

matter before healthy growth of plant life took place. The passage from plant to animal nutrition was illustrated by the chrysoomonad *Pedinella*. A similar change in nutrition was described amongst the Dinoflagellates. The line of progression from the flagellates to the metazoa probably proceeded through the cœlenterates, which represent the highest stage attained by the primary plankton or free-swimming animals. Further development took place when the latter established a connexion with the sea-bottom. Many of the bottom-living animals subsequently again adopted the free-swimming habit, and gave rise to the various groups of animals found in the plankton to-day. Fishes were probably evolved in rivers, and developed their swimming powers to resist the action of the current.

The conditions controlling the production of organic food material in the sea were discussed and some account given of the food-chain from the diatom and peridinian to the fish. Recent work by Hjort and Drummond was described, on the production of vitamin by marine plankton diatoms, and the passage of this growth stimulant through their food into the bodies of fishes, where it is found in the oil of the liver and subsequently in the ovary. In conclusion it was urged that for the solution of problems dealing with practical fisheries the life of the sea must be studied as a whole.

## HUMAN GEOGRAPHY.

DR. MARION NEWBIGIN'S address to Section E (Geography) was on "Human Geography: First Principles and Some Applications." Geographers are agreed that there is a definite human geography, but little attention has been given to the problem as to the precise way in which man's response to environmental conditions differs from that of animals. Since man once ran into a number of species—or even of genera—it is obvious that there was once a time when there was no distinctively human response, when adaptation led to specific differentiation, just as it does among animals. But since all living men now belong to one species, it is clear that this time has passed. Its passing appears to be associated with the fact that growing intelligence meant that the barriers to distribution which limit the movements of animals ceased to function. This in its turn might have meant that human evolution stopped, that man ceased to be adapted to any particular habitat because fitted for all, were it not that the factors of fixation and isolation, so important in the case of the lower organisms, began to act in a new way. With the growth of cultivation, communities became fixed to particular areas, and if the isolation was sufficient to ensure the necessary continuity and protection during the early stages, a communal as distinct from an individual adaptation appeared. The second part of the address dealt with applications of these general principles to the chief foci of civilisation in Europe and the adjacent lands. Thus the causes which promoted the origin, growth, and decay or modification of the successive cultures of the great river valleys, of the Mediterranean seaboard, and of the forest belt of Western Europe were considered, and the peculiar difficulties encountered in establishing stable communities in the steppe lands of Eastern Europe discussed briefly.

## RAILWAY PROBLEMS OF AUSTRALIA.

THE presidential address to Section G (Engineering), by Prof. T. Hudson Beare, was on "Railway Problems in Australia." Two great problems have to be faced by the Commonwealth—(1) the unification of the existing railway gauges, and (2) the joining up of the tropical areas of Northern Australia by a system of railways linking up with the railway systems of the southern and eastern areas of the continent.

(1) The first is a problem which has been prominent since 1888; up to the present no satisfactory solution has been found. Various Royal Commissions have inquired into the matter, and the only point which has been definitely settled is that the standard gauge shall be 4 ft. 8½ in. In 1921 a Royal Commission made two proposals—(1) to convert the main railway system connecting the various capitals from Fremantle to Brisbane to a uniform 4 ft. 8½ in. gauge, the length of track being somewhere about 3300 miles, the estimated cost of conversion and of the necessary new lines being 19,000,000*l.*, which would be increased to a total of 21,500,000*l.* if all the 5 ft. 3 in. lines in Victoria and South Australia were simultaneously converted to 4 ft. 8½ in.; (2) to convert the whole Australian railway system to 4 ft. 8½ in.—this the Commission estimated would cost about 57,000,000*l.*, but this estimate has not been accepted by the State railway authorities, and the Premier of South Australia at a recent conference stated that he was of opinion that the total cost would not be far short of 100,000,000*l.* sterling. If some mechanical device for overcoming the break-of-gauge difficulties could be evolved, the need for the expenditure of this enormous sum would be postponed to a period when it is to be hoped costs of constructional work would be greatly reduced.

(2) When the Commonwealth took over the Northern Territory from the State of South Australia on January 1, 1911, an agreement was entered into between the Commonwealth and the South Australian Government to the effect that the Commonwealth Government should construct a north-south railway connecting Port Darwin with Adelaide. It was agreed to construct a railway line from a point on the Port Darwin and Pine Creek railway southwards to a point on the northern boundary of South Australia proper, and a railway northward from a point on the Port Augusta and Oodnadatta railway to connect with the other portion of the line at a point on the northern boundary of South Australia proper. Up to the present no definite steps have been taken to carry out this agreement, but the Commonwealth Joint Standing Committee of Public Works last year appointed a sub-committee to investigate the country of this route and to take evidence. The Commonwealth Engineer for Ways and Works submitted two alternative transcontinental routes: (a) a direct north-south line with the necessary branches to connect it with the Queensland railways, estimated cost about 16,000,000*l.*, and (b) the eastern route, estimated cost about 14,300,000*l.*, to which must be added an additional sum of about 1,500,000*l.* if the existing 3 ft. 6 in. line from Port Augusta to Oodnadatta was extended to Alice Springs in order to open up the McDonnell Range country for closer settlement. The urgency for a prompt decision in regard to the route of the north-south line is brought

out by the fact that at the present time the journey by sea from Brisbane, the nearest State capital, to Darwin takes longer than the sea voyage from Darwin to Singapore or Hong-Kong, a perilous state of things to the Commonwealth in certain contingencies which need not be more emphasised but are obvious to all who are fighting so strongly for the white Australia policy.

## THE STUDY OF MAN.

IN his presidential address to Section H (Anthropology) Mr. Harold Peake said that during the last twelve years an anthropological school has arisen, which regards different groups of men as following, not one single path of evolution, but various routes according to their environment. This view has brought the anthropologist more closely into touch with the geographer, who has thereby become more human and less factual, has interested the sociologist and the economist, has infected many classical scholars, and may even wean the historian from a too exclusive study of kings and politicians. Anthropology may be defined as "the study of the origin and evolution of man and his works." As such it must be psychological as well as physical, dynamic rather than static. Nor must it be limited to the study of backward peoples, but extended to such civilised peoples as those of the Far East and Hindustan. We have much information concerning the arts, languages, and official religions of these regions; too little concerning the physical and mental traits of their "masses," their customs and actual beliefs. Such ignorance leads to constant misunderstanding and friction, as, for example, in India, and this can be removed only by giving our rulers there some training in anthropology. The British Schools at Rome and Athens have been of enormous value in establishing friendly relations. Let there be a British School in India, endowed by private benefactors of both races, to act as an anthropological centre from which would radiate a truer understanding of the ideals of both civilisations. The need for similar institutions in the European region is painfully manifest. It is, in fact, the spirit if not the detailed facts of anthropology which seem most likely to lead to that breadth of view and deeper sympathy which humanity requires. We need this not abroad alone; we have in these islands, as the result of successive invasions, various races, each with peculiarities of outlook which still lead to friction. These the anthropologist must study for the sake, not of knowledge only, but also for the sake of peace.

## THE EFFICIENCY OF MAN AND THE FACTORS WHICH INFLUENCE IT.

IN his presidential address to Section I (Physiology) Prof. Cathcart, after a brief discussion of the meaning of the term efficiency, in which he differentiated mechanical and industrial efficiency, went on to emphasise the intimate relation which exists between the efficiency of man in the physiological and industrial sense. There was a tendency to lay too much stress on organisation and machinery; to forget the fact that no matter what mechanical improvements were evolved man was always behind the machine, and that, therefore,

physiological laws must be reckoned with as an essential factor in industrialism. Attention was directed to the tremendous annual loss in time due to sickness and disability, and it was pointed out that primarily this wastage could not be charged to man being of unsuitable design for the work he was called upon to perform; on the contrary, the physiological balance of the organism was beautifully designed to meet most varying strains. After reference to the relation of the various systems, respiratory, circulatory, etc., to the maintenance of efficiency, Prof. Cathcart went on to discuss the factors which, in his opinion, play the predominant rôles in the maintenance of maximum efficiency. He believed that there were, at least, four intrinsic factors, *i.e.* factors directly related to muscle movement—(a) the rate of the performance of the work, (b) the amount of rest offered to or taken by the subject, (c) the rhythm with which the work was performed, and (d) the work habits developed by the worker. He reviewed each of these factors in turn; the influence of load and the type of work (positive and static) was dealt with under the rate of performance, and the formation of conditioned reflexes in connexion with rhythm and habit. The more extrinsic factors, *i.e.* those less directly related to muscle effort, were next discussed, including the influence of the state of nutrition and the nature of the food supplied, of the work environment, and the psychic factor generally, particular reference being made to monotony of occupation and the part played by the temperament of the worker. Other still more extrinsic factors like housing, personal habits, lighting, heating, ventilation, etc., were also mentioned. The general conclusion reached was that although the real over-all efficiency of the worker could not be causally related to any single factor, further scientific investigation along physiological lines, with the mutual co-operation of the employer, employee, and scientific worker, would throw much light on this most difficult and vitally important problem.

#### TRANSPORT OF ORGANIC SUBSTANCES IN PLANTS.

THE address to Section K (Botany), by Prof. H. H. Dixon, dealt with the transport of organic substances in plants. Organic substances are conveyed upwards in the rising transpiration and root-pressure currents. The transport is probably mainly effected in the tracheæ of the outer layers of the wood. Ringing may block these channels completely or partially by the introduction of air-bubbles and by exudations from injured cells into the lumina and walls of the tracheæ.

The downward transport of these substances from the leaves to the lower parts of the plant is usually assigned to the bast, although there is weighty experimental evidence that living conduits are not essential. Calculation shows that if the bast were used as the conduit a velocity of flow in it of about 50 cm. per hour would be required. In such narrow tubes as the bast is composed of, with frequent cross partitions and colloid contents, this velocity seems quite impossible. These considerations render it highly probable that the tracheæ of the wood are the path for downward transport also. There is ample experimental evidence for downward as well as upward movement of sap in the

tracheæ: Tension in the sap determines a flow from any source above or below. Resistance to transverse flow in the wood practically subdivides that tissue into a number of longitudinal filaments of tracheæ connected anatomically at various levels in the plant. Transpiration from the upper end of one filament may thus lead to a downward motion in a neighbouring one.

There is also conclusive evidence for this reversed motion in intact normal plants.

Recent work has shown that the transfer of stimuli from the receptive to the motile regions of plants is effected by the passage of hormones. In several cases it is certain that the hormones are conveyed in the transpiration current. Moreover, the movement is often basipetal. Such a downward flow is clearly available for the conveyance of organic food-stuffs as well as hormones. Local increases in the permeability of leaf-cells will allow solutions of organic substances to pass into the tracheæ. The tension generated in the sap by the transpiration of other leaf-cells will draw this solution downwards in the tracheæ. Experimental evidence for this method of transport is available. The volume-changes of leaves and parts of leaves observed during transpiration are in all probability the result of these changes in permeability, and are directly connected with the supply of organic substance from the leaf-cells to the transpiration-current for downward transport.

#### EDUCATIONAL AND SCHOOL SCIENCE.

SIR RICHARD GREGORY'S address as president of Section L (Educational Science) was a statement of the biological basis of education and a plea for broader conceptions of the scope and substance of science teaching in schools. It is the business of education to promote the right adjustment between the developing human organism and its surroundings, and this implies that the nourishment provided at all stages of growth should be not only such as supplies the needs of the moment but also builds up strength to live a full life under the conditions of the times. School instruction in science is not, therefore, intended to prepare for vocations, but to equip pupils for life as it is and as it soon may be. It is as essential for intelligent general reading as it is for everyday practical needs; no education can be complete or liberal without some knowledge of its aims, methods, and results, and no pupil in primary or secondary schools should be deprived of the stimulating lessons it affords. In such schools, however, the science to be taught should be science for all, and not for embryonic engineers, chemists, or even biologists; it should be science as part of a general education—unspecialised, therefore, and without reference to prospective occupation or profession, or direct connexion with possible university courses to follow. There is very present need for the reminder that science is not all measurement, nor is all measurement science. In the great majority of secondary schools science signifies chiefly quantitative work in physics and chemistry—laboratory exercises and lessons based upon them—and rarely is any attempt made to show the pupils what a wonderful world we live in, or what science has done, and is doing, for them in everyday life. By the prevailing obsession in regard

to quantitative work the pupil is made the slave of the machine, and appliances have become encumbrances to the development of the human spirit. In addition to subjects studied experimentally, there should be general science courses covering a wide field. Geo-

graphy can be made the unifying principle of such instruction. Practically all the subjects of a broad course of general science are of geographical significance, inasmuch as they are concerned with the earth as man's dwelling-place, and are the scene of his activities.

### The Royal Observatory, Greenwich.

THE Royal Observatory is situated in Greenwich Park on the edge of a scarp overlooking the Thames. The ground descends sharply to the north and west. On the east (running diagonally across the photograph) is a level avenue leading southwards to

especially with the view of their utilising predicted positions of the moon among the stars for the determination of longitude at sea. Some of the instruments employed by Flamsteed were in this room, but others were in the open. Under the octagon room are four

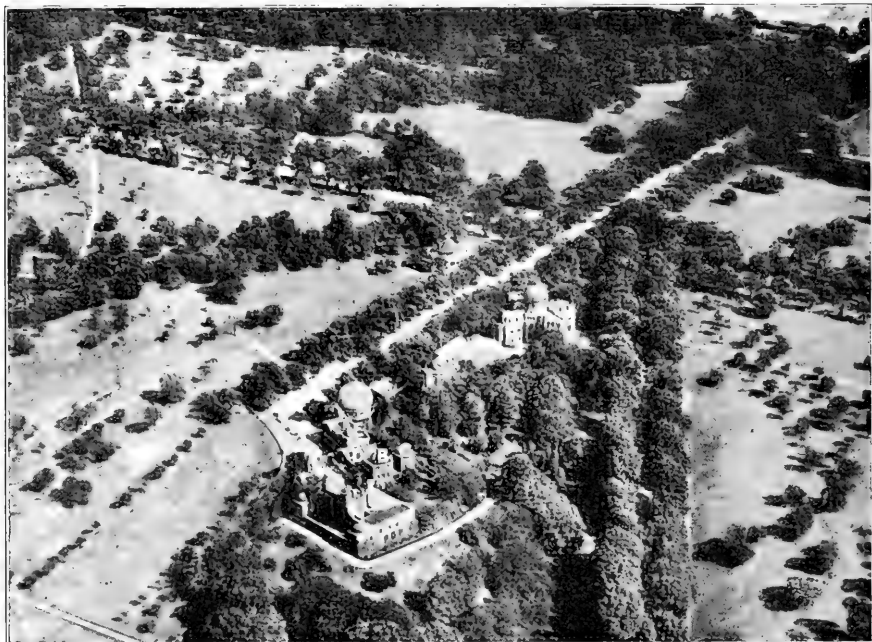

*Photo by Lentras Aerophoto Co., Ltd.*

#### THE ROYAL OBSERVATORY, GREENWICH.

A=ORIGINAL BUILDING. B=ASTROGRAPHIC EQUATORIAL. C=PHOTO HELIOGRAPH. D=TRANSIT CIRCLE.  
 E=SHEEPSHANKS TELESCOPE. F=8-INCH EQUATORIAL. G=ALTAZIMUTH. H=THOMSON EQUATORIAL.  
 I=MAGNETIC AND METEOROLOGICAL INSTRUMENTS.

Blackheath. This is joined at an acute angle a little south of the observatory by the avenue from Greenwich, which rises at moderate gradient to the level of the plateau.

The observatory was founded by Charles II. and designed by Wren. The original building, A, is shown surmounted by the time-ball at the north-east corner and anemometers on the north-west and south. The octagon room, so called from its shape, contained in this building was the observatory of Flamsteed, who was commissioned to make observations of the sun, moon, and planets for the assistance of navigators,

small rooms where Flamsteed lived. In Maskelyne's and Airy's time additions were made to the house by buildings to the south and west; the part of the Astronomer Royal's official residence looking over the western edge of the scarp is shown prominently in the picture.

To the south of the octagon room are shown two small domes. The first of them, B, covers the astrographic equatorial, a photographic telescope which was erected by Sir William Christie, and has done good service in the photographic mapping of the heavens, the determination of the solar parallax from observa-



tions of the planet Eros, and the determination of photographic magnitudes of stars.

Behind B, at C, is a drum-shaped dome beneath which Airy's altazimuth for observations of the moon was situated. This instrument was taken down in 1911 and a photoheliograph installed, with which the daily photographs of the sun are taken. These with photographs taken at the Cape and supplemented by others from India give a complete daily record of sunspots. They are measured and the results utilised to determine the peculiarities of the sun's rotation and the remarkable 11-year period in sunspots and their connexion with terrestrial magnetism.

To the east of the astrographic equatorial is the transit circle in a building, D, with a gable roof running north and south. This instrument, erected in 1851 by Airy, is on the Greenwich meridian. It has been in constant use for seventy years to determine Greenwich time, and with it regular observations are made for the positions of sun, moon, planets and stars. These observations have contributed very materially to the foundation of the tables and catalogues from which the "Nautical Almanac" is computed. In addition, many other stars have been observed for comparison with earlier observations made by Bradley and others at Greenwich and elsewhere. The small changes in position of the stars among themselves as seen in the sky determined in this way and combined with other data give the sun's motion in space, the average distances of stars, and prove the existence of two streams of stars.

To the left is a building, E, surmounted by a small dome containing the Sheepshanks telescope, used for observations of comets. These buildings also contain office rooms, record rooms, a small laboratory for receiving the wireless time signals from Paris, Bordeaux, Lyons, Nauen, Annapolis, and other stations, and rooms in which chronometers and watches are stored.

The large dome, F, contains the 28-inch equatorial. This large telescope was erected in 1893 on a mounting which had carried the 13-inch Merz telescope, which at the time of its erection in 1860 was the largest telescope in the observatory. The 28-inch refractor is used mainly for the measurement of close double stars.

The care of the chronometers and watches belonging to the Royal Navy is part of the work of the observatory, and the room beneath the large telescope is the main chronometer room; it contains ovens in which chronometers and watches are tested to see that they are correctly compensated. In this room is preserved the beautiful chronometer, made by Harrison, which obtained the Government prize of 20,000*l.*, and a copy of it made by Larcum Kendal which was carried by

Capt. Cook on his voyage round the world. On the ground floor is another room for chronometers and refrigerating plant for testing them at low temperatures.

A little to the south is the altazimuth, G. This was erected by Sir William Christie in 1896, and is used to supplement the observations of the moon made with the transit circle. A little south-east is a building used as a store-room, in which the publications of the Greenwich and Cape observatories are housed.

At the extreme south is the new building erected in 1896-1898. It is cruciform, and has on the main floor office rooms, where photographs are measured, calculations made, and observations discussed. The basement consists of libraries and a workshop. Three of the rooms of the upper floor are used for storing records and photographs, the fourth is used for photographic work, such as reproduction of the Franklin Adams Charts. The central part of the building is surmounted by the Thompson equatorial under a 36-ft. dome, H. This instrument, given by Sir Henry Thompson, consists of two telescopes on the same equatorial mounting. One of these is a 26-inch photographic telescope with a guiding telescope of 13 inches, and the other a 30-inch reflector made by Dr. Common. The photographic refractor has been put to many uses, including the observation of satellites and minor planets. It is at present used regularly for the determination of the distances of stars, delicate work which is carried on very successfully in spite of difficulties arising from weather and short summer nights. The reflecting telescope has been used for photographing nebulae, comets, and faint objects where great light-grasping power is required. With it a very faint and distant satellite of Jupiter was discovered. It is at present employed with a coarse grating to determine the colours of stars, or with a spectroscope to study the distribution of light in stellar spectra.

Only one important instrument is not shown in the photograph. The Cookson telescope, lent by the University of Cambridge and used for observation of small movements of the earth's pole, is in a small wooden hut to the east of the octagon room, and is hidden by that building.

Near the top left-hand corner, I, of the photograph is an enclosure in which are two buildings devoted to magnetic observations. Magnetic instruments had to be moved some distance from the main observatory, owing to the effect of iron in the domes on the magnets. Continuous photographic traces are taken showing the changes of the magnetic elements, controlled by regular observations made by eye. This enclosure also contains a radium collector for the study of atmospheric electricity, and various meteorological instruments.

### Colour Vision and Syntony.

By Prof. E. H. BARTON, F.R.S.

THE classic theory of colour vision due to Young and developed by Helmholtz and Maxwell attributes the observed phenomena to three sensations (red, green, and violet), but does not enter into detail as to the type of mechanism involved in their stimulus and response. In the days before the discovery of the electron, it was unlikely that any hypothesis of syntony

(or sympathetic vibratory response) should be developed for the eye, because nothing was then known of vibrators capable of such high frequencies as those involved in the visible spectrum. But it is now open to us to attempt a syntonic hypothesis of colour vision, since so much more is known as to the constitution of the atom and the behaviour of the electrons. The

fundamental facts which recommend the resonance theory of hearing are the smallness and rapidity of those motions which constitute the external stimulus of audition. But how much stronger is the argument based on the corresponding facts for vision! For in vision we are concerned with the frequencies of light, many millions of millions per second, and with displacements correspondingly minute. Further, we now know that in all receptions for wireless telegraphy there must be the tuning of a sympathetic vibrator before the detection of the excessively minute and rapidly alternating disturbances which constitute the signal.

Thus the question naturally arises, Can a syntonetic theory of colour vision prove tenable? To answer this we must review the main facts of the case, put forward a specific hypothesis based upon them, and test it against the facts.

**CHIEF FACTS OF COLOUR VISION.**—These may be classed under five heads: the spectrum, spurious colour mixtures, true colour mixtures, time phenomena, and colour blindness.

(i.) *The Spectrum* of white light extends over nearly an octave (to borrow the musical term) from red with a wave-length of nearly four-fifths  $\mu$  to violet of wave-length two-fifths  $\mu$ . The spectrum has no gaps in it, thus showing that we have continuous vision over the range in question. The colours change gradually all the way along the spectrum, and we have six or seven common names for the chief colours occurring. But Dr. Edridge Green finds that the spectrum can be divided into bands, each seeming monochromatic and each different from its neighbours. The number of these bands varies with the observer, but he finds it may reach from 18 to 27 for those with very sensitive colour vision.

(ii.) *Spurious Colour Mixtures.*—By mixing pigments (in water colour or oils) and by superposing coloured glasses or films we really execute a double subtraction of colour and not a true addition at all. Thus blue and green pigments mixed or blue and green glasses superposed almost always give green. This is because each pigment or glass subtracted (or absorbed) certain colours from the whole spectrum and left certain colours, and that of the colours thus left, green was the only one common to both residues. By the same methods red and green will give a low colour approaching grey, or it may give an absolute black. This last effect is easily obtained by superposing two good films, each of which transmits only a limited portion of the spectrum, with no colour common to both films.

(iii.) *True Colour Mixtures.*—These true additions of colour may be obtained by converging two or more coloured beams of light, by the colour top, or by stippling, weaving, or the various colour processes now used in book illustrations. These true mixtures give results quite different from those of the spurious mixtures and thus throw valuable light on colour vision. Thus blue and yellow do not make green but white or a light pinkish tinge; red and green make yellow; red, green, and violet make white, while red and violet give a colour not found in the spectrum.

(iv.) *Time Phenomena.*—It is known that the full acquisition of a visual sensation is not attained under something of the order of a tenth of a second, and that

the vision also persists for a like period after the stimulus is withdrawn, before dying out completely. Again, there are effects of fatigue, so that after gazing for twenty seconds at a red object and then at a white surface, a green image appears of the size and shape of the previous red object which had fatigued the eye for red and thus caused the white to appear deficient in red and so look green.

All the facts of colour vision hitherto enumerated apply to those with normal sight.

(v.) *Colour Blindness.*—Finally there are the facts of colour blindness. Some patients are blind to red, others are blind to green or to two of the three colour sensations, some are blind to all three.

**SYNTONIC HYPOTHESIS.**—In forming a syntonetic hypothesis of vision, in which the initial response of the eye to the stimulus of light is supposed due to the sympathetic vibration of something, we must indicate the number of different vibrators imagined to be present at each element of the retina, also the frequencies and dampings natural to them. Since the tri-colour theory of vision has been so successful in many ways it is natural to try first if three vibrational responders could form the basis of a syntonetic theory. Obviously if three responders are to suffice their "resonance" or response curves must replace the sensation curves usually drawn to indicate the degrees to which the three colour sensations are excited by the various spectral colours. These curves are much spread and overlap, so that no portion of the spectrum is left without power to excite one or more of the colour sensations. The response curves of the vibrators now postulated can be equally spread by rightly choosing the damping (or dying away of their free vibrations) natural to the vibrator. For, the greater the damping the flatter is the response curve, the less the damping the more sharply tuned is the response. Thus, by the hypothesis of three strongly damped responding vibrators we can account for the visibility of the continuous spectrum just as easily as by the vaguer hypothesis of three colour sensations. What natural frequencies must be assigned to these vibrators? Probably such as to respond to light of wave-lengths rather less than  $0.76\mu$ , about  $0.55\mu$ , and rather more than  $0.4\mu$ . Or we can think of the matter in musical terms as follows, rather sharper than  $C_2$ , about  $F_2$ , rather flatter than B, all three to be in the same octave.

*The Hypothesis Tested.*—We have now to test this postulated set of vibrators against the facts of true addition of colours. This test may be carried out mathematically or by experiments with a simple arrangement or model in which the vibrational responders are crudely imitated by pendulums RGV with paper cones as bobs (Fig. 1). (Any form or type of vibrators will serve equally well, as is shown by mathematical theory.) They hang from a stretched horizontal cord AB which is set in motion by the swings of a heavy pendulum CD, as shown in the accompanying figure. To represent a second light stimulus, simultaneously imparted, a second cord, AE, and pendulum FH are provided; the two cords are connected by a bridge of wood near  $v$  when both drivers are in action.

By the use of this model it is easy to make the desired tests of the hypothesis. In speaking of it we

may conveniently refer to the heavy pendulums by the names of colours, thus "red," if of the same frequency as the "red" responder *rR*, etc.

Tried in this way we find the simultaneous use of blue and yellow drivers does not give the response appropriate to green but gives white, *i.e.* all the three responders are set in motion. On reference to the diagram it is possible to see why this follows. The blue driver (representing blue light) is intermediate in frequency between the responders *Gg* and *Vv*, and so excites both. The yellow driver has a frequency between those of *Rr* and *Gg* and excites both. But the simultaneous drives on the green responder will interfere by being often much out of phase, so the response of the green responder is no more than those of the violet and red, indeed the last-named often preponderates. It should be noted that in the above test the

explained in the two hypotheses dealt with in this article on vision and the previous one on audition (see NATURE, September 2, p. 316). In the case of vision only three heavily damped responders are postulated in the single octave, whereas for hearing twelve lightly damped responders were postulated for each octave. The latter secures the finer analysis of which the ear is known to be capable, whereas the former agrees with the known lack of spectrum analysis in the eye. It still leaves power to discriminate twenty or thirty distinct colours in the whole spectrum, however, for if one pendulum CD be used as stimulus it may be changed gradually in length by twenty or thirty steps from the frequency corresponding to the violet responder to that of the red one, and at each adjustment the relative amplitudes of the three responders are appreciably different.

*Subsidiary Hypothesis.*—To meet the cases of colour blindness, one or more of the three responders is supposed to be absent or *abnormal* in frequency or damping. This opens out a wide field of possibilities.

To explain the time effects (the tenth of a second needed to acquire or lose the full visual sensation) a subsidiary hypothesis is put forward. The vibratory response is supposed only to initiate the process of vision by starting some changes of a physiological or chemical nature which in turn affect the nerves, these changes being, however, quantitatively dependent upon their vibratory initiation. When the light stimulus ceases

the vital activities are assumed to restore the changed materials of the retina to their normal states. Both changes are supposed to occupy something of the order of a tenth of a second.

The object of the present article was simply to show whether a syntonic hypothesis is adequate to explain the chief facts of vision. The conclusion is in the affirmative. But the hypothesis is not thereby established. We can only say that, if the hypothesis be true, colour vision would be, in the main, as we now experience it.

To suggest the exact nature of a probable or possible mechanism to carry out this syntonic hypothesis is another matter and beyond the scope of the present article. It was, however, discussed by Sir Oliver Lodge at the Bournemouth meeting of the British Association in 1919.

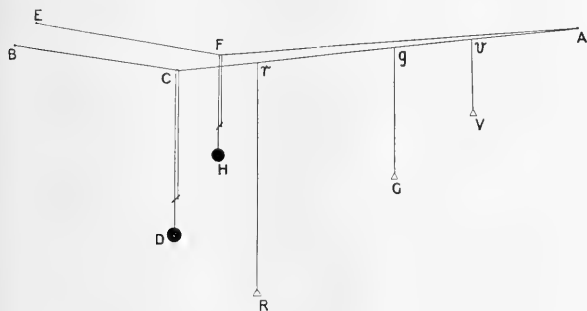

FIG. 1.

colours used as stimuli were both such as had no appropriate responder postulated.

For red and green the case is different; each has an appropriate responder provided in the hypothesis, and each is affected by the corresponding stimulus when red and green pendulums are used as drivers. But when a yellow driver is used, *i.e.* a pendulum intermediate in frequency between the red and green responders, they are both affected as when the separate red and green drivers were in use. Thus, on the hypothesis under examination, the naked eye would mistake a true addition of red and green for a yellow. And this is just what happens when the experiment is tried.

This is quite different from what occurs in hearing, where two notes like C and E when sounded simultaneously are not mistaken for any single intermediate note. This distinction is, however, adequately

## Obituary.

PROF. J. A. POLLOCK, F.R.S.

PROF. JAMES ARTHUR POLLOCK, professor of physics in the University of Sydney since 1899, who died after a short illness on May 24, at the age of fifty-seven years, was a fine physicist and a man of exceptionally high, loyal, and unselfish character. He was born in or near Cork, and was educated at the Manchester

Grammar School and the Royal University of Ireland, taking an engineering degree. He and his brother, Hugh Pollock (they were inseparable), were intended to enter some linen-manufacturing business in which his family were interested; but this proving a disappointment in some way, the young men with their father and some other members of their family went to Sydney about 1884. Arthur Pollock obtained an appointment at the

Sydney Observatory, but soon gave it up to enter as a student at the University, to the great regret of the Government Astronomer, H. C. Russell. He took the B.Sc. with the university medal for physics in 1889, and in 1890 was appointed demonstrator in physics under Sir Richard Threlfall, who at that time occupied the chair of experimental physics. On Threlfall's return to England in 1899 Pollock succeeded to the professorship, which he held up to the time of his death. He was president of Section A of the Australian Association for the Advancement of Science in 1909, was secretary of the Royal Society of New South Wales for the last eleven years of his life, and was elected F.R.S. in 1916.

When the Australian Mining Battalion was formed for work in France about 1915, Pollock at once joined with the rank of captain—the fact that he was fifty years old at the time naturally made no difference to a man of his character. Soon after he got to France he was put in charge of the school for training officers in "listening" underground by means of geophones and related devices. The school was near Poperinghe, within easy reach of Messines and other points of the line where tunnelling was in progress, and he took his full share in the nervous work of estimating how near our tunnels were to the German works. It was characteristic of him that having noticed that in binaural listening with geophones some observers were much more effective than others, he used his opportunities to estimate the minimum retardation of phase which would cause the sound to go "round the head." He finally discovered a young Russian who was so sensitive that he could point the geophone indicator in the direction of the sound with an accuracy of the same order as is attainable by visual means!

After the mining period was over Pollock was moved to Farnborough, where he worked at the problems of aeroplane navigation with the rank of major until the end of the war; but his real contribution to the final victory lay in the way he conducted the school at Poperinghe, where all instruction in "listening" was practically in his hands.

Pollock's experimental work in physics, contained in some twenty papers, is characterised throughout by his striving for accuracy and the avoidance of ambiguity. His early training at an observatory coloured all his work. Whatever the apparatus was, the best result must be got out of it, and when the work was published nothing must appear that was not really essential. His skill in adjusting instruments has probably scarcely ever been equalled, as may be seen by reference to a joint paper on a gravity balance (*Phil. Trans.*, 1899, Vol. A, 193). In this work, whatever degree of success was attained may be attributed mainly to Pollock's skill and devotion: the late Mr. Duddell—no mean judge in such matters—once told the writer that had the thing not been done he should have regarded it as impossible.

During the years 1890 to 1895 Pollock was greatly interested in optical experiments. He had acquired great skill in making the adjustments required when using the Michelson-Morley classical apparatus, and with it made some observations of the effect of the velocity of a stream of water on light passing through it. Like many other of his experiments no publication was made, because he considered that the conclusions

he came to did not constitute an advance on existing knowledge.

After 1900, for some years Pollock's work was mainly directed to establishing the relations between the geometrical constants of a conductor and the wavelength of the electromagnetic radiation obtained from it. The accurate figures obtained were very welcome at the time, and he returned to the subject at a later date. The apparatus was then used for the determination of the specific inductive capacity of a sheet of glass at high frequency 24,000,000 (Pollock and Vonwiller). Measurement was repeated at a frequency of 50, and no appreciable difference in specific inductive capacity was found. This work was then extended to Selenite by Vonwiller and Mason as a supply of well-purified material was available. The value obtained, again practically the same whether the frequency was high or low, namely, 6.13 at 16° C. by low frequency and 6.14 by high frequency at 23.6° C., is probably the most trustworthy figure extant for the material in the physical state described in the paper. As the measurement was not made in Germany, it is doubtful whether it will ever reach a text-book.

The above investigations were followed by an experimental and theoretical investigation of the application of the ionic theory of conduction to the carbon arc—especially in regard to the phenomena of "re-lighting" (Pollock, Wellisch, and Ranclaud), 1909, but for several years Pollock's experimental work was much interrupted by the illness of his brother, to whom he was devoted and to whom much of his scanty leisure was given—he died some years ago.

Probably the most important work done by Pollock was his investigation of the ions of the atmosphere (*Phil. Mag.*, 29, 1915, pp. 514 and 636, and *Proc. Roy. Soc. N.S.W.*, Oct. 1909). Starting with the "large ions" discovered by Langevin, Pollock showed that their mobility was definitely related to the relative humidity of the air; applying a thermo-dynamic argument to his observations he concluded that the large ions condensed water in the liquid phase. He then discovered a new class of ions intermediate in mobility between Langevin's ions and free ions, and by the same thermo-dynamic argument indicated that in this case the ion was weighted with water in the vapour phase.

The two papers quoted give a very good idea of Pollock's powers as a physicist, since he allowed his scientific imagination more scope than usual. Among minor contributions his description of an automatic Sprengel pump and an investigation of the mode of formation of very small bubbles in frothing solutions may be mentioned. In fact, his exposition of froth formation (*Phil. Mag.*, 1912) is exceptionally clear and judicious.

In 1914 Pollock returned to his observations on the relation of the length of electromagnetic waves to the length of a "straight terminated" rod in which they are generated, and more recently was applying his experience in acoustics, obtained during the war, to the investigation of the action of the stethoscope and to the study of the velocity of sound through earth.

As a colleague Pollock was ever cheery and obliging, but his courteous manner covered a character of great firmness, and if he had once made up his mind as to the propriety of any line of conduct he could not be turned

from it. On the whole, both Pollock's life and work were determined by an almost Roman sense of duty, and his output of scientific investigation (considerable though it was) was limited by the severe view he took of his obligations as a teacher.

PROF. TADEUSZ GODLEWSKI.

TADEUSZ GODLEWSKI was born on January 4, 1878, the youngest son of the distinguished plant physiologist, Dr. Emil Godlewski, Sr., who was for many years a professor in the Jagellonian University of Cracow. After receiving his early education at the St. Anna School in Cracow, Godlewski entered the philosophical faculty of the Jagellonian University in 1897, and graduated in 1903, the subject of his dissertation being the osmotic pressure of solutions. Between 1901 and 1903 he worked under Prof. A. W. Witkowski as demonstrator in the University Physical Laboratories, and then proceeded to Stockholm for a year's post-graduate study with Prof. Svante Arrhenius, from whose laboratory he published a paper on electrolytic dissociation.

In October 1904 Godlewski travelled to Montreal and entered the laboratory of Sir Ernest Rutherford, by whom he was initiated into radioactive research, and under whose guidance he published three papers on radioactivity during the following year. On his return to Poland in 1905 he was appointed demonstrator, in 1906 assistant professor, and in 1910 full professor of physics at the Technical High School, Lwów (Leopol or Lemberg, Poland), and for the academic year 1918-1919 he was elected Rector of that institution. In 1921 he was elected a Corresponding Member of the Polish Academy of Science and Letters in Cracow. He died on July 28, 1921, from the effects of a slow poisoning, resulting from a coal-gas leak in his laboratory.

Godlewski's later work was devoted mainly to radioactive and electro-chemical problems, and he published numerous original papers. His nature was kindly and lovable, and those who knew him could not but feel the charm of his personality. During the period of my association with him in Vienna in 1915, he looked forward to the dawn of better days for a united Poland, and I well remember his unutterable grief at the death of his friend Smoluchowski in 1917, when he wrote me: "This is truly the greatest calamity that could have befallen us." During the last few years Poland has suffered the loss of several eminent men of science, whom she could ill spare, whose foresight and influence would have been invaluable in her policy of scientific and educational reconstruction. International science, too, mourns the loss of such men as Olszewski, Rudzki, Danysz, Smoluchowski and Godlewski.

R. W. L.

M. L. FAVÉ.

THE death of M. Louis Favé after an illness of several weeks occurred on July 31. Before his retirement M. Favé was the chief hydrographic engineer to the French Navy, and the greater part of his forty years' administrative service was devoted to the study of tides, to coastal surveys, and to the configuration of

oceanic basins. He was interested chiefly in the observational side of such work, and especially so in connexion with the invention and construction of new scientific instruments for those purposes. Among these may be mentioned a very efficient device for the damping of small periodic movements in such instruments as mariners' compasses; he also devised instruments for the navigation of balloons.

His most outstanding achievement, however, for which M. Favé deservedly received great credit, was the invention of the Favé tide-gauge. This ingenious instrument, designed for the continuous registration of tidal heights in the open sea, was invented in 1887 and has received continuous development. It is essentially a pressure gauge and registers the variations in pressure by means of two Bourdon gauges on a rotating piece of smoked glass, from which measurements are made with the aid of a microscope. One of the advantages of the instrument is that it can be left without attention at the bottom of the sea for a fortnight. By various devices M. Favé was enabled to obtain records in fairly deep water, and recently he claimed successful operation at a depth of 400 metres. The applications of such an instrument as this are very interesting and important; for instance, Whewell suggested the existence of a point about half-way between England and Holland, where the vertical movement of the sea is zero, and the Favé gauge has been used to supplement other observations, so proving the existence of such a point.

The news of M. Favé's death will be received with much regret by all who are interested in hydrography.

THE death is announced from New York of Dr. Jokichi Takamine, at the age of sixty-eight years. Born in Japan, Dr. Takamine was educated at the Imperial University and afterwards in Glasgow at Anderson College. While in Glasgow he worked at the enzymes of fungi and introduced the useful preparation known as "taka-diastase." He returned to Japan in 1881 and, after marrying an American lady, went to the United States in 1890, became attached to Messrs. Parke, Davis and Co. as consulting chemist, and set up a laboratory of his own. His chief scientific achievement was the separation of adrenaline from the supra-renal bodies. Much of his time was spent in travelling between the United States and Japan. He thus played an important part in facilitating the relations between these countries.

WE notice with regret that Dr. Sophie Bryant has met her death by accident near Chamonix. She left her hotel at Montanvert on August 15 to walk to Chamonix, and her body, bearing marks of several injuries, was found on August 28. She appears to have wandered from the usual path and to have fallen on to a rock. Dr. Bryant was the first woman in the British Isles to receive the degree of doctor of science, and she was headmistress of the North London Collegiate School for Girls from 1895 to 1918.

WE regret to see the announcement of the death, on August 27, of Dr. David Sharp, F.R.S., at the age of eighty-one years.

## Current Topics and Events.

H.R.H. THE PRINCE OF WALES, who is patron of the Ramsay Memorial Fund, has consented to unveil on Friday, November 3, at 12 noon, the memorial tablet of the late Sir William Ramsay which is being placed in Westminster Abbey. The tablet has been executed by Mr. Charles L. Hartwell and was exhibited at the Royal Academy this summer. Invitations will be sent out in October. Any communications with respect to the unveiling should be addressed to the organising secretary of the Ramsay Memorial Fund, Dr. Walter W. Seton, at University College, Gower Street, London, W.C.1.

"INTELLECTUAL CO-OPERATION" is the phrase, sufficiently comprehensive, employed by the Council of the League of Nations to designate the field of investigation of a commission set up by it in May last. This body, consisting of twelve members, among whom are Profs. Henri Bergson (president), Gilbert Murray (vice-president), Madame Curie-Sklodowska, and Prof. A. Einstein, held its first session at Geneva on August 1-5. The commission had been given a free hand to define its own programme with due regard to existing national activities and existing organs of international intellectual life. The following were among the topics selected for consideration: the desperate economic condition of the *intelligenza* in some European countries—notably Austria and Poland; the protection of proprietary rights in scientific discoveries and ideas; the establishment of an international *entente* for the examination and publication of archaeological monuments; inter-university relations; and an international organisation of bibliography: All these questions have been referred to individual members of the commission or to sub-commissions for the preparation of reports with the view of taking further action. As for co-operation in scientific research, the commission, anxious not to interfere in the organisation or work of the scientific societies, decided that this should be left to the initiative of the societies themselves. Another question on which the commission found itself unable to take any useful action was the publication by common consent of workers in all parts of the world of discoveries relative to toxic gases and the development of chemical warfare. It decided to reply to the Reduction-of-Armaments Commission, which had referred the question, that it was unable to suggest methods whereby this result might be brought about.

A REPORT of the European Health Conference (League of Nations), held at Warsaw in March last, has been issued. It contains a general report of the work of the Health Organisation since its initiation in 1920, a summary of information received from delegates, minutes of plenary meetings, and reports of various sub-committees on the cost of measures required and the needs of various states, with four useful charts showing the epidemic situation in Eastern Europe. Dr. Rajchman, the secretary, summarised the results achieved by the conference, and explained the plan of campaign devised to fight epidemic disease. That there is need for this will be

realised when it is stated that during 1922 there were many districts in Eastern Europe with thousands of cases of typhus and relapsing fevers, and cholera.

FROM the Otago University Museum we receive the Annual Report for the year 1921, drawn up by the curator, Prof. W. B. Benham, professor of biology in the University, who says that "in the not distant future it will be necessary to build a new Biological Department altogether distinct and separate from the Museum, and to divorce the functions of professor and curator, now nominally carried on by one individual." Fortunately, Prof. Benham has a most capable assistant in Mr. H. D. Skinner, who is well known as an ethnologist, but that branch of science and his duties as Hocken Librarian absorb all his time. To judge from the work recorded in the present report, there is more than enough to occupy all the energies of a full-time curator, as well as the additional technical assistants for whom Prof. Benham calls. We note that the Chinese colony in Dunedin has subscribed the sum of 35*l.* to provide cases for a recent donation of Chinese objects. When the rest of the population takes equal interest in the Museum, the just demands of Prof. Benham may perhaps be fulfilled.

THE Trieste Academy of Science and Art announces a competition for the best contribution upon the subject of "Partial Differential Equations of Maxwell-Lorentz." Three prizes will be given. The competition is open to all nationalities. Contributions must bear a pseudonym and be accompanied by a sealed envelope with the name and address of the competitor. The latest date for the receipt of contributions is December 31, 1922. The papers will be published in the *Annals of the Academy*. Further information may be obtained from the secretary of the Academy of Science and Art, Trieste, High Foscolo Street, 2.

A CENTENARY celebration of the birth of Gregor Mendel is to take place at Brünn, Czecho-Slovakia, on September 22-24. A monument to Mendel's memory was erected at Brünn in 1910, and in the succeeding twelve years the fundamental significance of the principle which he discovered has been still more widely recognised and applied in biology. The programme of the celebration will include addresses on the personality and work of Mendel, as well as papers by prominent Mendelians from various countries, and an excursion to neighbouring caves and to Mazocha. The programme is in the hands of a local committee, and inquiries or contributions should be sent to Dr. Hugo Iltis, Bäckergasse 10, Brünn, Czecho-Slovakia.

A SUMMARY of the weather for the past summer, comprised by the thirteen weeks ended August 26, is given in the *Weekly Weather Report* published by the Meteorological Office for the week ended August 26. The highest temperature in any district of Great Britain was 86° F., which occurred in the north-west of England. The north of Scotland was the only district where the thermometer failed to touch 80° F. Mean temperature was everywhere below the normal.

the deficiency ranging from 2°·6 in the east of Scotland and 2°·5 in the west of Scotland to 1°·3 in the north-east of England. Rainy days were slightly above the normal except in the north-east of England and in the Channel Islands. The total rainfall was in excess of the normal in all the eastern English districts and in the south-west of England; the excess was greatest in the Midland Counties, amounting to 2·44 in., the next largest excess being 0·83 in., in the north-east of England. The duration of bright sunshine was generally deficient and ranged from 7 hours per day in the Channel Islands to 4·6 hours in the north of Scotland. At Greenwich the mean temperature for the three summer months, June to August, was 60° F., which is 4° cooler than for the corresponding period last year; June was slightly the warmest month, and after June 19 the thermometer failed to touch 80° during the remainder of the summer, a feature similarly outstanding in 1920 and 1910. The total rainfall for the three summer months in London was 6·7 in., and July was the only month with an excess of rain; the total for the three months was a quarter of an inch above the normal and more than five times greater than in the corresponding three months last year. Bright sunshine in London was 150 hours less than in the corresponding quarter in 1921; August was the least sunny month.

THE Report of the National Physical Laboratory for the year 1921 covers more than 200 pages and gives outlines of many of the researches which have been in progress during the year, with sufficient diagrams to enable the reader to understand the methods and apparatus in use. The outstanding events in the history of the Laboratory for the year are:—the presentation of a bas-relief of Sir Richard Glazebrook executed by M. Cluysenaar of Brussels, which has been erected in the hall entrance of the administrative building with the back of Sir Richard's head towards the entrance; the unfortunate disaster to airship A.38 at Hull, which involved the loss of two of the most valued members of the aeronautics' staff; and the completion of the new buildings for the Admiralty Research Laboratory, and some of those sanctioned by the Treasury in 1920. Funds for the Physics building and for the extension of the Metallurgy building are not yet available. Research for the fighting services has grown considerably during the year, and the Research Associations established by the Department of Scientific and Industrial Research have been responsible for an extensive programme of work, though with one or two exceptions all departments record a decrease in the number of tests made. Dr. J. A. Harker, one of the original members of the staff, has resigned to take up a consulting practice, and Dr. G. W. O. Howe is going to Glasgow University as professor of electrical engineering.

We learn that Messrs. Taylor, Taylor, and Hobson, Ltd., of Leicester, the makers of the well-known Cooke lenses, have now become associated in business with Messrs. Bellingham and Stanley, Ltd., of 71 Hornsey Rise, London, N.19. It is hoped that by pooling the knowledge and resources of the two firms

the interests of the British optical industry will be promoted, and that additional economy of manufacture will be secured.

WE have received a copy of the first number of the *Record of Photography*, a journal to be issued monthly by the Professional Photographers' Association. It is devoted to the interests of professional and trade photographers and is not to compete with any existing publications. It has the feature, probably unique, that the pages of text are each backed with advertisements, so that any part may be cut out for filing without the loss of other matter (except advertisements) on the back. Accompanying it are two good reproductions of portraits by Mr. Pirie MacDonald of New York.

THE last number received of the *Revista de Sciencias* (Rio de Janeiro) contains articles on the new survey of Brazil, Poincaré's mathematical philosophy, clinical forms of *Granuloma ulceroso*, and the dynamic theory of the seismograph. There are notes on the mathematical theory of muscular work, on the occurrence of rare earths in Brazil, the determination of the constants of a thermionic valve, geological notes on the Ceara region, notes on some plants which furnish material for the study of protoplasmic currents, and a general summary on the mineral resources of Brazil as well as shorter notes and articles on other subjects.

WE have received a catalogue of microscopes and microtomes from the Bausch and Lomb Optical Co. (37 and 38 Hatton Garden, E.C.). A great many different types of microscope stands are listed, ranging from the simplest to complex models for advanced research and of the binocular pattern. Achromatic, fluorite, and apochromatic objectives and eye-pieces of all types are supplied, as well as all the usual accessories. The microtomes include the well-known small and large Minot forms. Many of us had an opportunity during the war of using the Bausch and Lomb instruments, and found them eminently satisfactory, both mechanically and optically. The prices compare favourably with those of other makers.

MESSRS. GEORGE BELL AND SONS, Ltd., will publish this month, under the title of "Bell's Mathematical Tables," a new book by Dr. L. Silberstein, suited to the requirements of the mathematician and the theoretical physicist. The work will be in two parts, the first containing the usual logarithms of numbers and of the fundamental trigonometric functions. The second and larger part will contain a collection of mathematical formulæ, definitions, and theorems, together with tables of the more important special functions, such as elliptic integrals, Bessel functions and spherical harmonics, Fresnel integrals, etc. Another book in Messrs. Bell's list of announcements is "A Text Book of Machine Construction and Drawing," by H. E. Merritt and M. Platt, the object of which is to provide a thorough and comprehensive exposition of the subject for engineering students. It will cover intermediate requirements, and be of service to more advanced students as a book of reference. A further book by the same authors on the subject of machine design for the use of degree students and designers is in active preparation.

## Our Astronomical Column.

**AUGUST METEORS.**—The great shower of August Perseids was not well observed this year in consequence of cloudy weather and moonlight. A rich display of Cygnids was, however, witnessed during the last half of the month from the point  $291^{\circ} + 50^{\circ}$  near  $\theta$  Cygni. The individual members of this stream were brilliant with swift motion and short paths. At the end of their flights many of them burst with a sudden acquisition of brightness. The shower is fairly well known and gave an abundant display in 1893. In that year, between August 4 and 16, 28 of its meteors were seen at Bristol, while 40 were recorded by Mr. Corder at Bridgwater, and 30 by Mr. Blakeley at Dewsbury. A full description of the shower appeared in the *Observatory* for September 1893, and the explosive character of the meteors was specially pointed out. The visible strength of the shower varies from year to year, but its period has not yet been ascertained; further observations are required of this particular stream, for it is certainly one of the most important of the many systems which are in contemporary activity with the well-known Perseids.

**MARS.**—The first drawings of Mars at the present apparition are published in *L'Astronomie* for July. They were made by M. Mentore Maggini at Catania. One, made on May 23, accords with the description of M. Jarry-Desloges of the paleness of the dark markings at this period, presumably due to their being covered by a veil of mist or dust. This seems to have dissipated by June 1, a sketch on that date showing these regions dark, especially Syrtis Major; the southern end of it is flanked by two brilliant white patches. Nephthes is very prominent, and widely double. The drawing indicates 15 other canals. Both polar caps are shown, the southern being the larger. Dr. Fountain in the B.A.A. Journal for June 28 ascribes the red colour of the Martian deserts to ferric oxide, and suggests that owing to the escape of the lighter gases the Martian atmosphere may be relatively rich in oxygen, so that meteoric dust would tend to become oxidised.

**THE FRYE REFLECTING TELESCOPE.**—The 100-inch Hooker Telescope is not long to remain the largest in the world. Mr. T. S. H. Shearman, Government Meteorologist at Vancouver, has successfully cast a speculum of 10 feet diameter and 50 feet focal length which is to be erected in the new observatory planned by Mr. Chas. H. Frye at Seattle. This observatory is to be open to the public at certain times; the telescope will then be used in a horizontal position, being fed with light by a plane mirror; but when it is employed for the photography of nebulae or other faint objects it will be pointed directly at the sky. The cost of the instrument is in the neighbourhood of 300,000 dollars, and is apparently being borne wholly by Mr. Frye. The above particulars are taken from Circular No. 1 of the Frye Observatory, which also states that Mr. Shearman expected to make the first astronomical observation with the new speculum before the end of July.

**VARIABLE STARS NEAR M. 53.**—Dr. Baade gives in *Mitteilungen der Hamburger Sternwarte*, Bd. 5, No. 16, an account of a photographic search for variables near the globular cluster M. 53. It resulted in the discovery of 7 variables within a region extending from R.A.  $13^{\text{h}} 1^{\text{m}}$  to  $13^{\text{h}} 13^{\text{m}}$ , and from Decl.  $+17^{\circ} 39'$  to  $+19^{\circ} 41'$ . Five of them are of the cluster type, with periods between  $\frac{1}{3}$  and  $\frac{2}{3}$  of a day. Applying

Shapley's rule for the absolute magnitudes of these stars, their distances, in units of 1000 light-years, are 16, 20, 23, 41, 62 respectively. The last named, the mean magnitude of which is 16.25, appears to be a member of the globular cluster, though distant  $34'$  from its centre. The others are probably unconnected with the cluster. Since the latter is in galactic latitude  $79^{\circ}$ , the results suggest a much greater extension of the sidereal system in this direction than that indicated by Prof. Kapteyn, who concluded that the star-density became sensibly zero at a distance of some 10,000 light-years towards the galactic poles.

**ABBREVIATIONS OF CONSTELLATIONS' NAMES.**—In the printing of Star Catalogues in which reference is made to the names of the constellations, a large amount of valuable space is wasted in consequence of the lack of a standard system of an abbreviated nomenclature. At the meeting of the International Astronomical Union held at Rome in May last, the Commission on notation, units, and economy of publication decided on a system of abbreviations which involve only three letters for each constellation. Thus, to give a few examples, And is Andromeda; CMa, Canis Major; CVn, Canes Venatici; Gem, Gemini; etc. In the Harvard College Observatory Bulletin, No. 771, it is stated that this system will be adopted forthwith. It is expected that it will now be used universally, since it is a great economy and convenience in printing, especially when large catalogues of stars with their magnitudes, positions, proper motions, spectrum types, parallaxes, etc., are in hand.

**NEW NEBULAE.**—In the Harvard College Observatory Bulletin, No. 773, it is announced that Mr. Donald H. Menzel has found recently approximately two thousand new nebulae on ninety photographs made with the 24-inch Bruce telescope at Arequipa, the southern hemisphere station of the Harvard College Observatory. Most of the new objects are south of declination  $-45^{\circ}$ ; their positions and descriptions will be published later. Of the eight hundred brightest nebulae found by Mr. Menzel, about thirty-five per cent. appear to be spirals, *i.e.* they show spiral arms or the characteristic spindle form. The majority of the other bright objects are stated to belong probably to the type designated by Hubble as globular nebulae. It is interesting to note that the total number of nebulae now recorded is nearly 20,000.

**A VERY MASSIVE STAR.**—Much attention is now being given to the determination of the masses of stars, so that any star of excessive mass becomes at once an interesting object. Dr. J. S. Plaskett, Director of the Dominion Astrophysical Observatory at Ottawa, describes (*Mon. Not. R.A.S.*, vol. 82, p. 447) the star B.D.  $6^{\circ} 1309$ , No. 2422 of the Harvard Revised Photometry, which consists of two very bright Oe stars, *i.e.* stars at nearly the highest temperature, 10,000 light years away from us; they revolve around one another in an elliptic orbit in a period of 14.414 days, but are separated by a distance of 90,000,000 kilometres. The brighter of the two stars has a probable mass of at least 86 times that of the sun, a density of 0.01, and an absolute magnitude of  $-5.65$ . The fainter star has a mass of 72 and is of the same density, its absolute magnitude being  $-5.4$ . The absolute magnitude of the system as a whole is  $-6.3$ , which is the greatest so far determined.



## Research Items.

**NEOLITHIC SCRIPT IN INDIA.**—The recent discovery of two neoliths, one from Chota Nagpur, the other from Assam, said to be marked with decipherable scripts, has attracted some attention. On one of these Prof. Bhandarkar read the word "Maata," assumed to mean "a headman or chieftain." The script is believed to be that known as the Brahmi, which, according to Bühler, was introduced in India from Semitic sources about 800 B.C. Unfortunately, however, there is no evidence that this character was ever written from right to left. The question of these neoliths has been examined by Mr. Hem Chandra Das Gupta in the Journal of the Asiatic Society of Bengal (vol. xvii. No. 2), who points out that the evidence of provenance and of the fact that the inscriptions date from the Neolithic Age is far from satisfactory. Symbols like letters of the alphabet have been found in European soil painted upon pebbles belonging to a stratum between the Palæolithic and Neolithic Ages at Mas d'Azil in France, but scholars are still doubtful whether these so-called inscriptions form a scientific basis for investigation of the origin of the alphabet. The same may be said of these recent Indian discoveries.

**THE SWASTIKA, GAMMADION, FYLFOT.**—The familiar symbol known in India as the Swastika, or omen of good luck, and in the West as the Gammadion or Fylfot, has generally been interpreted to represent the sun in its apparent course. Its origin has been investigated by Mr. Harit Krishna Deb in the Journal of the Asiatic Society of Bengal (vol. xvii. No. 3). He suggests that it is based on the method of writing the sacred syllable Om; afterwards typical of the Brahmanical triad of deities. This, when written in the Brahmi character, takes the form of two crossed pot-hooks, which he regards as the earliest form of the Swastika. This theory meets with the serious objection that while this symbol comes down from the Bronze Age at least, and is found on pottery from the Third City at Hissarlik, the Brahmi alphabet, according to Bühler, was derived from a Semitic source about 800 B.C. Mr. H. K. Deb suggests that some of the Brahmi characters may be of indigenous origin in India, while others were adopted from Semitic scripts, but there is no evidence of this. Nor is there any reason to believe that the Swastika was adopted for the first time in India. The interpretation now suggested may be regarded as not proven, unless we are prepared to believe that in this specialised form it is peculiar to India, and the solar explanation may for the present be regarded as holding the ground.

**INSECTIVORA FROM THE CONGO.**—The collections made by the American Museum Congo expedition are gradually being worked out and the results published. The latest section dealt with concerns the Insectivora and was the work of the well-known American zoologist J. A. Allen, who, alas, died without seeing the final proofs (Bull. Amer. Mus. Nat. Hist., vol. xlvii.). The Soricidae were described in the same Bulletin in 1916 by N. Hollister, but the gist of his work is here repeated to make the whole subject complete. Fifty-two species and subspecies are chronicled, of which only two are, however, new.

**FORAMINIFERA OF THE ATLANTIC OCEAN.**—The third part of an important monograph on the Foraminifera of the Atlantic Ocean by J. A. Cushman has just made its appearance (Bull. U.S. Nat. Mus., 104). The first part, dealing with the Astrorhizidae, was published in 1918 (see NATURE, vol. cii. p. 51), and the second on the Lituolidae in 1920. The present

part includes the family Texulariidae, which is apparently more primitive than most of the other families of the Foraminifera, and follows the Lituolidae in its general characters, a number of the simpler genera being wholly or in part composed of species with arenaceous tests. In the most primitive subfamily, the Spirolectinae, a coiled development makes up a considerable portion of the test. A number of new species are described, and there are twenty-six excellent plates.

**HAWAIIAN NATURAL HISTORY.**—The Bernice Pauahi Bishop Museum of Polynesian Ethnology and Natural History continues its useful career, and its "Occasional Papers" have reached the eighth volume. Three of the latest numbers bearing on natural history are now before us. C. Montague Cooke, jr. (vol. vii. No. 12), supplies "Notes on Hawaiian Zonitidae and Succineidae." Among the former the author includes Vitrina, which has long been placed in a family of its own; he elevates Godwinia into a subfamily on anatomical grounds; and founds a new genus Nesovitrea for the *Vitrea paucillus* of Gould. To the Succineidae he adds two new species of Catinella, and creates a new genus, Laxisuccinea, for two new fossil species. Adequate illustrations of anatomical details are given in the text, and there are two plates of the shells from the pencil of Miss Winchester, which is a guarantee of their worth. The Stomatopoda in the Museum are the subject of a paper by C. H. Edmondson (vii. No. 13). The collection comprises 53 specimens, of which one is new. The same writer also treats of the Hawaiian Dromiidae (viii. No. 2), amounting to four species, of which one, *Dromidia hirsutissima* (Lamk), recorded by Dana, has not been seen by him, and he considers its occurrence doubtful.

**ECOLOGY OF SOUTH AUSTRALIA.**—An interesting contribution to the study of arid regions, with special reference to the vegetation, has been prepared by Mr. W. A. Cannon ("Plant Habits and Habitats in the Arid Portions of South Australia." Washington: Carnegie Institution, 1921). The importance of bringing under cultivation those portions of the earth's surface which, at present, are of more or less desert nature, is becoming increasingly important in face of the growing demands for food of the world's population. The studies of the physical, geobotanical and ecological characteristics of such areas are being carried out by our American friends with their typical vigour and freshness of outlook and are already proving of practical value. In the work under notice the varying vegetational features are correlated with the rainfall in the districts which they inhabit, an arbitrary classification of regions being based on the annual amount of rain. It is shown that in South Australia as a whole the flora is distinctly of a xerophytic type, and that of the dry northern portion differs from the rest only in degree and not in kind. The total absence of deciduous species is noteworthy. The morphological and ecological peculiarities of the species of Acacia and Eremophila are especially considered. The halophytes, mainly species of Chenopodiaceae and Amarantaceae, constitute the most prominent element of the flora of the very dry districts. *Triodia irritans* and *Spinifex paradoxus* are among the most frequent grasses. The work is illustrated by 32 pages of photographs, some showing characteristic landscapes and vegetational features, and others peculiarities of root, shoot or leaf morphology. There is a bibliography and a summary of contents but no index.

**EXPERIMENTAL SILICOSIS OF THE LUNGS.**—It is well known that the inhalation of dust particles in various industries may be provocative of serious fibrotic and other changes in the lungs. This obtains particularly among grinders, file-makers, and clay workers, while other dusts, notably coal dust, are much less harmful. The miners on the Rand suffer much from silicosis, due to the inhalation of silica particles derived from the quartz, and A. Mavrogdato has investigated the question experimentally by causing guinea-pigs to breathe dust-laden air of various kinds over varying periods (Publications of the S. African Institute for Medical Research, No. xv. 192). He finds that the solubility and chemical activity of dust, e.g. silica, are the important factors inducing fibrotic changes in the lungs, hardness and sharpness of the particles being of little importance. The majority of the particles entering the lungs are less than  $1\mu$  in diameter. The particles do not penetrate the tissues, but the tissues take up the particles by means of phagocytic cells. The silica-laden cells block lymphatics and thus prejudice the lungs' ability to deal with infections, and hence secondary tuberculous infection is common.

**THE BACTERIAL FLORA OF GREENLAND.**—Samples of the soil and of the faecal matter of polar animals collected by Dr. T. Wulff in North Greenland in 1916 and 1917 were examined bacteriologically by Dr. C. Barthel in Copenhagen. Nineteen species of bacteria were isolated from the soil and identified. They included such well-known forms as *B. subtilis*, *S. flava*, *B. mesentericus*, and *B. zopfii*. Almost all the soils contained nitrates, and in some, nitrifying micro-organisms were detected. In addition, denitrifying, ammonising, urea-fermenting, and butyric forms were found. In the faecal matter of such animals as the blue fox, arctic hare, crow, seal, polar bear, lemming, and white partridge a variety of aerobic and anaerobic organisms was isolated, including *M. candidans*, *Strep. faecalis*, *B. putrificus*, and others. The results obtained indicate the ubiquity of many species of bacteria, both simple saphrophytes of the soil and of the animal intestine, and special putrefactive and nitrifying forms. (Recherches bactériologiques sur le sol et sur les matières fécales des animaux polaires du Groënland Septentrional. Den II. Thule Ekspedition til Grønlands Nordkyst 1916-18. Nr. 1. Copenhagen, 1922.)

**PRECIPITATION IN THE UNITED STATES.**—A notice of the new precipitation section of the Atlas of American Agriculture is given by Prof. Robert De C. Ward in the U.S. *Monthly Weather Review* for March. Notice has previously been given of the monthly, seasonal, and annual rainfall charts, but the fresh material to complete the precipitation section has recently been sent in the form of loose sheets to some to whom the material is of immediate practical use, prior to the final issue. The records are for a uniform period of 20 years, 1895-1914, from about 1600 stations, and in addition shorter records are used from about 2000 other stations. The object of the publication is to benefit agriculture, and it lays marked emphasis upon the departures which may be expected from the average, so that the farmer may decide for himself what crops he may plant with the greatest probability of success. Numerous charts and graphs are given. The percentage of the annual precipitation occurring between April and September 30 is highest, more than 70 per cent., over most of the great agricultural region of the eastern United States, embracing the eastern Plains and Prairie States. Frequency and intensity of precipitation are shown

in great detail for the whole country. Day and night rain percentages are separately given, and it is shown that over the great agricultural states east of the Rocky Mountains large sections receive more than half, and considerable areas receive about two-thirds of their warm season rains at night, and there is therefore much less rapid evaporation. Snowfall is considered, and the annual number of days with thunderstorms, and the distribution of fog and cloudiness are given.

**THE STANDARD ATMOSPHERE.**—In aeronautical and artillery calculations it is now necessary to know the condition of the atmosphere at heights up to 20 kilometres with a degree of accuracy not previously required, and each nation is at present concerned to define a mean condition from which the actual condition within its borders at any time will deviate only by relatively small amounts. It has been found that Toussaint's formula  $t - 15^\circ = 0.0065z$ , where  $z$  is the altitude in metres, gives the mean temperature throughout the year up to 10 kilometres, above which the temperature is constant at  $-55^\circ\text{C}$ . The observations in the United States set on foot by the American National Advisory Committee for Aeronautics have, according to Report No. 147, prepared by Mr. W. R. Gregg, established the applicability of the formula to that country. The report also shows that the hypsometric equation based on Toussaint's formula leads to values of the pressure in agreement with observations, and that the density at any level may be calculated from the pressure and temperature by the "perfect gas" equation.

**SENSITISERS FOR THE EXTREME RED.**—In the *British Journal of Photography* for August 11, Drs. C. E. K. Mees and G. Gutekunst describe three new sensitisers for the extreme red, giving their properties and methods of preparation. They are suitable either for adding to the emulsion or for bathing ready prepared plates, with the exception noted below. Betanaphtha-cyanole gives a strong maximum at  $690\mu\mu$ , and sensitises the green markedly less than pinacyanol. Acetamino-cyanole added to an emulsion gives a strong maximum at  $730\mu\mu$ ; but in dilute aqueous solution as prepared for bathing plates it appears that the acetyl is hydrolysed off, and its effect is much restricted. Kryptocyanine gives a very strong maximum at  $760\mu\mu$ , and even at  $850\mu\mu$  its sensitising power is greater than that of dicyanine, but beyond this point dicyanine is the more advantageous, and at  $900\mu\mu$  kryptocyanine is almost useless. It does not sensitise in the green, and therefore may prove to be of special value in astronomical photography. On account of their peculiarly advantageous properties, naphthacyanole and kryptocyanine will be added to the list of sensitisers prepared and supplied by the Research Laboratory of the Eastman Kodak Company.

**CANNED FOODS.**—The Food Investigation Board has issued a special report (No. 10, 1s. 6d. net) on methods used for the inspection of canned foods (Part II., Canned Marine Products), compiled by Dr. William G. Savage. Attention is directed to the want of uniformity in procedure adopted by food inspectors. Much experimental work was carried out, but no tests were evolved more trustworthy than those in vogue for distinguishing swiftly and accurately between the safe, the dubious and the unfit tins. A "blown" tin is clearly a bad tin, but a tin with an abnormal shake sound or a springy top or bottom is merely a suspect sample. An organisation is suggested whereby better results and greater uniformity of inspection of canned foods might be obtained.

## The First Messel Memorial Lecture.

DR. RUDOLPH MESSEL came to England in 1870 and died here in 1920. During the fifty years of his residence in this country he was engaged in the manufacture of sulphuric acid; he was a chemist of considerable repute, a fellow of the Royal Society, an accomplished and kindly man; by his will he left the whole of his fortune to the Royal Society and the Society of Chemical Industry. The council of the latter Society decided to set aside a small part of the legacy to found a series of Messel Memorial Lectures to be delivered by eminent chemists, each of whom is to receive a Messel medal. The first of such lectures was delivered in Glasgow last July by Prof. H. E. Armstrong, who was for very many years an intimate friend of Dr. Messel. The lecture is now published in the issue of the *Journal of the Society of Chemical Industry* for August 15.

The subject of the lecture is "Chemical Change and Catalysis," but Prof. Armstrong contrives to make sundry alarms and excursions into adjacent territories. There is a good and sympathetic account of the life and work of Messel, some amusing chaff of Ostwald and his school of ionic chemists, of Bancroft and his satellites, of colloid chemists and most other varieties of chemists, and an important contribution to our conceptions of the processes involved in chemical change. The lecture is important not so much because of the new matter in it, but because it puts the problem in an arresting manner and compels those readers who have any power of thought to cry a halt for a moment and consider first what the lecturer means, and then what the reader really thinks on this subject, and whether a good deal of what he has been in the habit of thinking is sound or not. Prof. Armstrong has long scoffed at text-books and has very successfully practised a method of teaching, the vital principle of which is to tell very

little and make the pupil do a good deal of thinking and investigating. He continues to practise his method, if this lecture is any criterion of his present habits. The view he outlines is that no chemical change takes place except in the presence of an electrolyte, which he calls the "determinant"; unless the substances concerned are in an electric circuit chemical activity is suspended. The work of Prof. H. B. Baker on the inactivity of perfectly dry substances is referred to several times. Electrolytic conductivity is discussed and the electrolysis of water; according to the lecturer this takes place in stages, the first stage being the formation of hydrogen peroxide; this unstable compound plays an important part in the association views of Prof. Armstrong: it is the first stage in the oxidation of hydrogen. The combustion of carbon monoxide, the oxidation of xanthin and hypoxanthin are discussed, and there is some account of catalysis, the action of enzymes, and the nature of acids.

The determination of Prof. Armstrong or perhaps his catalytic nature compels the mind of the reader to execute a sort of Brownian movement. He is driven from Gowland Hopkins to Meredith, from hydroxylation to Hudibras, from colloids to Lewis Carroll. And when he thinks, good, easy man, full surely the argument is ripening, he is switched off to a quotation from Erasmus Darwin or some new paradox about the basic properties of sulphuric acid, in a manner which those who are familiar with Prof. Armstrong's style will easily imagine, although they cannot—one scarcely knows whether to say fortunately or unfortunately—imitate it.

No one will begin this lecture without finishing it. No one will fail to be interested and amused; no one will come to the end without a stimulus to thought, a renewed curiosity as to chemical change, a new scepticism, and fresh ideas.

## Stellar Radiation in the Infra-red.

DR. W. W. COBLENTZ<sup>1</sup> is developing the application of the thermocouple to the study of stellar radiation, and is deriving results of considerable interest and value, especially so far as red stars and red variables are concerned. The instrument he uses is not so sensitive as the photo-electric cell which is doing such delicate work in the hands of Guthnick, Stebbins, and others, but it lends itself more readily to the investigation of radiation in the longer wavelengths.

Most workers engaged on spectrophotometric measures of the stars have concentrated on the visible spectrum. Dr. Coblentz uses various transmission screens which allow only radiation over fairly narrow regions of the spectrum to pass through to the thermocouple. He thus obtains the spectral energy distribution of the stars, and derives stellar temperatures agreeing fairly closely with the values obtained at Potsdam by Wilsing, Scheiner, and Münch. The chief interest lies in the extension to their work that he makes by using a water absorption cell, which is transparent for radiation between  $0.3 \mu$  and  $1.4 \mu$  in the infra-red, and does not absorb much radiation less than  $0.5 \mu$  in wave-length. When the transmission through a layer of 1 cm. of water is only a small fraction of the incident radiation as in the case of  $\alpha$ -Orionis and  $\alpha$ -Scorpii, then Dr. Coblentz rightly concludes that the total radiation from these stars is far higher than is suggested by their visual magnitudes. It appears that we are faced with the fact

that photo-visual methods can give us trustworthy magnitudes of stars only for a limited range, and that certain stars, especially novae, radiate with much greater intensity in the extreme ultra-violet than we are allowed by our atmosphere to measure, while others—the red stars and invisible dark stars—radiate with great intensity in the infra-red.

Even within the range where visual methods have prevailed, Dr. Coblentz shows that the failure to take into account the infra-red radiation has given much too small a value for the luminosity, or intensity of radiation, of the giant red stars. This may account for the puzzling fact which Prof. Russell recently proclaimed, that giant stars of all spectral classes were of about the same absolute magnitude. Dr. Coblentz's evidence is that this is not the case, but that the giant red stars are radiating far more energy than are the giant blue stars of the same visual absolute magnitude.

A further point of interest arises from the close relation between a star's spectrum and the transmission of its radiation through a water-screen. When more radiation is lost in passing through the screen than is normal with the spectral class to which a star belongs, this has been traced to the presence of a dark companion to the star which makes its presence known in yet a new way by the action of its hitherto unnoticed infra-red radiation. It is to be hoped that the method may be made more sensitive, or that some more sensitive measure of infra-red radiation may be developed which will enable the astronomer of the next century to measure the radiation from the dark nebulae and—it is not an impossible thought—to plot the dark stars on the next *Carte du Ciel*.

<sup>1</sup> Scientific Papers of the Bureau of Standards, No. 438. "Tests of Stellar Radiometers and Measurements of the Energy Distribution in the Spectra of 16 Stars." Washington, 10 cents.

## University and Educational Intelligence.

**BIRMINGHAM.**—The following appointments have been made: Assistant Professor K. N. Moss to be professor of coal and metal mining; Prof. G. Haswell Wilson to be professor of pathology in succession to Prof. Shaw Dunn; and Mr. T. H. P. Veal to be assistant lecturer in civil engineering.

**CAMBRIDGE.**—The Chancellor of the University has appointed Prof. H. R. Dean, professor of pathology in the University of Manchester, to be professor of pathology in succession to the late Sir German Sims Woodhead.

THE Salters' Institute of Industrial Chemistry has awarded fellowships for post-graduate study to Messrs. C. G. Harris, W. S. Martin, J. H. Oliver, and W. Randerson, and has renewed the fellowship of Mr. F. R. Jones.

A PROSPECTUS has been issued from the chemistry department of the Borough Polytechnic Institute, Borough Road, S.E.1, for the coming session. In addition to the customary course in general and organic chemistry, electro-chemistry, and the chemical technology of the essential oils, a grouped series of courses have been arranged, for this session, to meet the needs of students taking the National Certificate in Chemistry. There will also be a series of lectures on the chemistry of foodstuffs and a course on chemistry as applied to the laundry industry. In assessing the fees payable by students, special consideration is given to apprentices, while there is a special scale for students residing outside the county of London.

THE convenient practice of issuing abridged and sectional calendars adopted by the authorities of Battersea Polytechnic, Battersea Park Road, S.W.11, has been continued for the coming session. The abridged calendar of afternoon and evening classes gives some idea of the scope of the institution's activities; courses are provided in mechanical, civil, and electrical engineering, pure and applied mathematics, physics, chemistry and technological chemistry, hygiene, photography, and domestic science. The fees are fixed for students residing in the London area while at the Polytechnic, but for those residing outside the county an additional fee, generally equivalent to the difference between the ordinary school fee and the cost to the London County Council of the student's education, is charged.

It is announced in *Science* that Prof. A. Sommerfeld, of the chair of mathematical physics at the University of Munich, will be in residence at the University of Wisconsin for the first part of the academic year 1922-23, holding the Karl Schurz memorial professorship in the university for that period. The Karl Schurz memorial professorship was founded in 1910 in memory of Karl Schurz, of Watertown, Wisconsin, sometime member of the board of regents of the State University, as an exchange professorship with the German universities, and the appointment of Prof. Sommerfeld marks the resumption of the professorship after the interruption caused by the war. Prof. Sommerfeld is expected to lecture on atomic structure, and on either the analysis of wave propagation or the general theory of relativity.

## Calendar of Industrial Pioneers.

**September 10, 1827.** George Medhurst was buried.—The projector of the atmospheric railway, of which he published descriptions in 1812 and 1827, Medhurst was born in 1759, began life as a clock-maker, and was afterwards a machinist in Soho. Various atmospheric railways were constructed, but not till some years after Medhurst's death.

**September 12, 1870.** Karl August Steinheil died.—Born in Alsace in 1801, Steinheil in 1835 became a professor in Munich, where he invented a form of electric telegraph. During 1849-1852 he was director of the Department of Telegraphs at Vienna, while three years later he founded an optical institute at Munich.

**September 12, 1914.** Edward Riley died.—Riley's name is associated with two great advances in the manufacture of steel. As a young chemist at the Dowlais Iron Works in 1857 he made experiments on the Bessemer process, while some twenty years later as a consulting chemist he was associated with Thomas Gilchrist in the introduction of basic linings in converters. He was also a pioneer in the accurate analysis of iron and steel.

**September 13, 1906.** Hubert Henry Grenfell died.—A pioneer in the development in modern gunnery, Grenfell, when first lieutenant of H.M.S. *Excellent* in 1869, with Chief Engineer Edward Newman, worked out the first design of hydraulic mounting for naval ordnance. Retiring in 1886 he joined Armstrong's of Elswick, and in 1891 invented self-illuminated sights for night firing.

**September 14, 1882.** Georges Leclanché died.—An inventor who by a single invention won a world-wide reputation, Leclanché was for some years chemical engineer in the laboratory of the Chemin de Fer de l'Est. His well-known battery was patented in 1867.

**September 14, 1892.** Rudolph Proell died.—Trained at the Technical Academy in Berlin, Proell became a professor in the Technical High School at Aix-la-Chapelle, but afterwards as a consulting engineer devoted himself to the development of automatic valve gears.

**September 14, 1907.** Leveson Francis Vernon-Harcourt died.—Educated at Harrow and Balliol College, Oxford, Vernon-Harcourt, after graduating in 1862, became a pupil of Sir John Hawshaw. From 1882 to 1905 he was professor of civil engineering in University College, London, and was widely known as an authority on all that concerns tidal harbours, rivers and estuaries. In 1895 he served as president of the Mechanical Science Section of the British Association.

**September 15, 1859.** Isambard Kingdom Brunel died.—Among the engineers of the first half of the nineteenth century Brunel holds a high place. He assisted his father on the construction of the Thames Tunnel, became engineer to the Great Western Railway, introduced the broad gauge, and was the designer of the Clifton Suspension Bridge and the Albert Bridge at Saltash. With his three ships, the *Great Western*, 1838, *Great Britain*, 1843, and *Great Eastern*, 1857, he made notable contributions to the advancement of naval architecture. He is commemorated by a window in Westminster Abbey.

**September 16, 1871.** Dennis Hart Mahan died.—For forty years Mahan was professor of civil and military engineering at the Military Academy, West Point, and published works on these subjects, his course of civil engineering being translated into various foreign languages. He was one of the incorporators of the American National Academy of Science.

E. C. S.

# NATURE

A WEEKLY ILLUSTRATED JOURNAL OF SCIENCE.

*"To the solid ground  
Of Nature trusts the mind which builds for aye."*—WORDSWORTH.

No. 2759, VOL. 110] SATURDAY, SEPTEMBER 16, 1922 [PRICE ONE SHILLING

Registered as a Newspaper at the General Post Office.]

[All Rights Reserved.]

## BALANCES & WEIGHTS

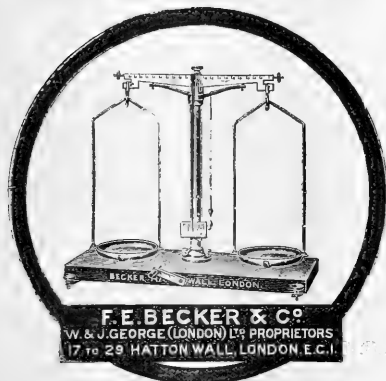

**F. E. BECKER & CO.**  
W. & J. GEORGE (LONDON) LTD PROPRIETORS  
17 to 29 HATTON WALL, LONDON, E.C.1.

**REYNOLDS & BRANSON, Limited,**  
Chemical and Scientific Instrument Makers to His Majesty's  
Government (Home and Overseas Dominions), Laboratory  
Furnishers and Manufacturing Chemists.

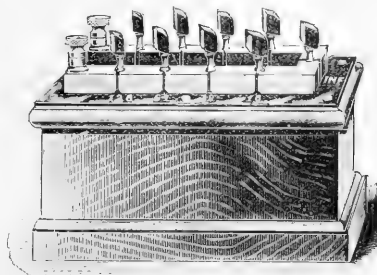

Resistance Boxes, P.O. Boxes, etc., manufactured in our own  
Workshops

See Physical Catalogue. Post free on application.

14 COMMERCIAL STREET, LEEDS.

## SPECTROMETERS

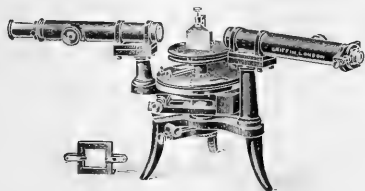

Particulars and Prices on application to—

**JOHN J. GRIFFIN & SONS, LTD.**  
Kemble Street, Kingsway,  
London, W.C.2.

## HIGH RANGE THERMOMETERS

Of Guaranteed Accuracy.

NATIONAL PHYSICAL LABORATORY  
certificate of N. & Z. Thermometer No. D 10520.

Reading.	Correction.
212 F.	0° F.
300	0
400	0
500	+1
600	+1
700	0
805	0

Above is a copy of certificate of a Thermometer  
recently verified.

**NEGRETTI & ZAMBRA**  
38, HOLBORN VIADUCT E.C.1.  
LONDON.

## THE SIR JOHN CASS TECHNICAL INSTITUTE,

JEWRY STREET, ALDGATE, E.C.3.

Principal—CHARLES A. KEANE, D.Sc., Ph.D., F.I.C.

**Evening Classes** designed to meet the requirements of those engaged in Chemical, Electrical, Metallurgical, Petroleum, and the Fermentation Industries and in trades associated therewith.

### CHEMISTRY.

H. J. S. SAND, D.Sc., Ph.D., F.I.C.  
E. DE BARRY BARNETT, B.Sc., F.I.C.  
P. C. L. THORNE, M.A., M.Sc., A.I.C.  
J. W. COOK, M.Sc.

### PHYSICS AND MATHEMATICS.

D. OWEN, B.A., D.Sc., F.Inst.P.  
R. H. HUMPHRY, M.Sc., A.Inst.P.  
A. E. R. CHURCH, M.A., B.Sc.  
G. F. ROSE, B.A.

### METALLURGY.

GEO. PATCHIN, A.R.S.M., M.I.M.M.  
W. A. C. NEWMAN, B.Sc., A.R.S.M., F.I.C.  
L. SINGLEHURST WARD, B.Sc.

### BREWING AND MALTING.

H. LLOYD HIND, B.Sc., F.I.C.

### MICRO-BIOLOGY.

ARTHUR HARDEN, D.Sc., Ph.D., F.R.S.

### PETROLEUM TECHNOLOGY.

J. S. S. BRAME, F.I.C.  
J. MCCONNELL SANDERS, F.I.C.  
A. FRANK DABELL, M.Inst.Mech.E.  
J. L. JEFFERY, A.R.S.M., M.I.M.M.

## MECHANICAL DRAWING AND MATERIALS OF CONSTRUCTION AND DESIGN.

W. J. BURTON, O.B.E.  
B. HEASTIE, A.M.I.C.E.

## DIFFERENTIAL EQUATIONS AND VECTOR ANALYSIS.

A. E. R. CHURCH, M.A., B.Sc.

## ALTERNATING CURRENTS AND ELECTRICAL OSCILLATIONS.

D. OWEN, B.A., D.Sc., F.Inst.P.

### COLLOIDS.

E. HATSCHER, F.Inst.P.

## METALLOGRAPHY AND PYROMETRY.

O. F. HUDSON, D.Sc., A.R.C.S.

## ANALYSIS OF ENGINEERING WORKS MATERIAL.

L. SINGLEHURST WARD, B.Sc.

## SCIENTIFIC AND TECHNICAL GERMAN.

W. R. SCHOELLER, Ph.D., A.I.C.

The Institute contains well-equipped laboratories in which every facility is provided for

### ADVANCED STUDY AND RESEARCH

both in the *afternoon* and *evening*.

Preparation for the Pass and Honours B.Sc. Examinations of University of London under recognised teachers of the University. The Institute is also recognised for the training of candidates for the Examinations of the Institute of Chemistry, and the Institute of Physics.

NEW SESSION commences SEPTEMBER 25.

ENROLMENT WEEK, Monday, September 18, to Friday, September 23, 6.30 to 8.30 P.M.

For details of courses apply at the Office of the Institute or by letter to the PRINCIPAL.

## CHELSEA POLYTECHNIC,

CHELSEA, S.W.3.

Session begins September 25, 1922.

Day and Evening Courses in Science under Recognised Teachers of London University.

### I. INDUSTRIAL CHEMISTRY DEPARTMENT.

Technical Courses in Analytical and Manufacturing Chemistry, Pharmacy, Food and Drugs, A.I.C. Courses, Metallurgy, Assaying, Foundry Work, Research.

### II. INDUSTRIAL PHYSICS DEPARTMENT.

Practical work in General Physics. Applications to Industries, Metrology, Calorimetry, Illumination, Acoustics, Electrical Measurement, Research.

### III. BIOLOGICAL AND GEOLOGICAL DEPARTMENT.

Courses for B.Sc., etc., in Botany, Geology, Mineralogy, Zoology, Special Courses in Bio-chemistry, Bio-physics, Bacteriology, Physiology, Hygiene, Entomology, Plant Pathology. Course for Tropical Planters, Research.

SIDNEY SKINNER, M.A.,

Principal.

Telephone: Kensington 899.

## BIRKBECK COLLEGE.

(UNIVERSITY OF LONDON.)

Principal—GEORGE SENTER, D.Sc., Ph.D., F.I.C.

**EVENING COURSES** for the Degrees of the University of London in the Faculty of Science and for the Geography Diploma.

Facilities are also provided during both day and evening for Post-Graduate and Research Work.

Calendar, 1s.; by post, 1s. 5d. Prospectus free.

For full particulars, apply to the SECRETARY, Birkbeck College, Fetter Lane, E.C.4.

## BATTERSEA POLYTECHNIC,

LONDON, S.W.11.

Principal—ROBERT H. PICKARD, D.Sc., F.R.S.

Head of *Chemical Department*—J. KENYON, D.Sc., F.I.C.

**APPLIED BACTERIOLOGY.**—J. H. JOHNSTON, M.Sc., F.I.C.  
1st year course.—Lectures and Lab. Tuesday, 7 to 9.30. September to Easter. \*Fee, 20s.

2nd year course.—Lectures and Lab. Friday, 7 to 9.30. September to Easter. \*Fee, 20s.

3rd year course.—Wednesday, 7 to 9.30. September to July. \*Fee, 20s.

**ANALYSIS OF FOODS, WATERS, FERTILISERS AND FEEDING STUFFS.**—J. H. JOHNSTON, M.Sc., F.I.C. Lectures and Practical. Wednesday, 7 to 9.30. September to July. \*Fee, 20s.

**THE TESTING OF DISINFECTANTS.**—J. H. JOHNSTON, M.Sc., F.I.C. 10 Meetings, commencing Tuesday, April 24, 1923. 7 to 9.30. \*Fee, 10s.

\* A higher fee will be charged to students not resident in London.

Evening classes commence September 25, 1922.

Enrolment commences September 16, 1922.

Particulars of all classes on application to the PRINCIPAL.

## BATTERSEA POLYTECHNIC.

Principal—\* ROBERT H. PICKARD, D.Sc., F.R.S.

University Courses, day and evening, under Recognised Teachers of the University of London are provided in Science, Engineering and Music.

**CHEMISTRY.**—\* J. KENYON, D.Sc., F.I.C.; \* J. L. WHITE, D.Sc.

**PHYSICS.**—\* S. MARSH, B.Sc., Ph.D.; \* A. E. EVANS, B.Sc.; \* J. F.

PHILLIPS, B.A., B.Sc.

**MATHEMATICS.**—\* F. M. SAKELLY, M.Sc., B.A.; \* F. W. HARVEY,

B.Sc., M.A.; \* W. G. BICKLEY, M.Sc.

**MECHANICAL AND CIVIL ENGINEERING.**—\* W. E. M.

CUSNOCK, M.Sc., B.Eng.; \* J. R. SHAW, A.R.C.S., Wh.Ex.; \* H. M.

EDWARDS, B.Sc.; \* V. C. DAVIES, B.Sc., A.M.I.Mech.E.

**ELECTRICAL ENGINEERING.**—\* A. T. DOVER, M.I.E.E.,

A.Am.I.E.E.; \* H. C. MARR, A.M.I.E.E.

**MUSIC.**—\* H. D. WETTON, Mus. Doc., F.R.C.O.

\* Denotes recognised teacher of University of London.

There are also—

Day Technical College in Engineering and Science. Day Training

College of Domestic Science. Day Department of Hygiene and

Physiology. Day School of Art and Crafts.

Evening Courses in Engineering, Chemistry, Physics, Mathematics,

Bacteriology, Chemical Engineering, Hygiene and Physiology, Art,

Matriculation Subjects, Domestic Economy, Music, Physical Training.

Hostels for Women Students. Large playing fields at Merton.



SATURDAY, SEPTEMBER 16, 1922

## CONTENTS.

	PAGE
The Progress of State Afforestation . . . . .	369
The Green Flash at Sunset. By Sir Arthur Schuster, For. Sec. R.S. . . . .	370
Village Communities. By H. J. F. . . . .	371
Climbing Palms and the Sago Palms. By A. W. H. . . . .	372
The Control of Electric Power. By A. R. . . . .	373
A Modern Text-book of Chemistry. By Prof. H. B. Baker, F.R.S. . . . .	374
Our Bookshelf . . . . .	374
Letters to the Editor :—	
Capillarity.—Wilson Taylor . . . . .	377
The Influence of Science.—Rev. A. L. Cortie, S.J. The Production of a Standard Source of Sound.— Capt. E. T. Paris . . . . .	378
Occurrence of the Rare Whale, <i>Mesoplodon Layardi</i> , on the Tasmanian Coast.—Prof. T. Thomson Flynn . . . . .	379
Atoms and Electrons.—Robert N. Pease . . . . .	379
The Freshwater Winkle.—A. E. Hodge . . . . .	380
The Effect of a Lead Salt on Lepidopterous Larvæ.— Dr. F. C. Garrett and Hilda Garrett. . . . .	380
The Pigeon Tick.—A. G. Lowndes . . . . .	380
The Theory of Numbers. By Prof. G. H. Hardy, M.A., F.R.S. . . . .	381
The Organisation of Research. By Principal J. C. Irvine, C.B.E., D.Sc., LL.D., F.R.S. . . . .	385
The Total Solar Eclipse of September 21. By Dr. A. C. D. Crommelin . . . . .	389
The Deflection of Light in a Gravitational Field. By Herbert Dingle . . . . .	389
The British Association at Hull. SUMMARIES OF ADDRESSES OF PRESIDENTS OF SECTIONS . . . . .	391
Current Topics and Events . . . . .	393
Our Astronomical Column . . . . .	395
Research Items . . . . .	396
Einstein's Theories . . . . .	398
Educational Work of the Ministry of Agriculture University and Educational Intelligence . . . . .	398
Calendar of Industrial Pioneers . . . . .	400
Societies and Academies . . . . .	400
Official Publications Received . . . . .	400

Editorial and Publishing Offices :

MACMILLAN &amp; CO., LTD.,

ST. MARTIN'S STREET, LONDON, W.C.2.

Advertisements and business letters should be  
addressed to the Publishers.

Editorial communications to the Editor.

Telegraphic Address: PHUSIS, LONDON.

Telephone Number: GERRARD 8830.

NO. 2759, VOL. 110]

## The Progress of State Afforestation.

THE Geddes Committee recommended the abolition of the Forestry Commission, and the discontinuance of the scheme of State afforestation that was sanctioned by Parliament in 1919. Fortunately these drastic measures were not adopted by the Government. The Treasury, however, has now restricted the Commissioners' operations, by reducing considerably the annual instalment from the forestry fund, which had been fixed at 350,000*l.* In consequence, the forestry staff has been greatly reduced, all purchase of land for the purpose of afforestation is suspended, and planting operations are greatly curtailed. It is discouraging to be aware of these facts, while reading the second annual report<sup>1</sup> of the Forestry Commissioners, which is a record of continuous progress till the end of September 1921.

The report shows unexpected ease in the acquisition of suitable land for planting trees. In order to reduce current expenditure to a minimum, the policy has been pursued of leasing as much and buying as little land as possible. In September 1921 the Commissioners were actually in possession of 68,489 acres of "plantable land," of which two-thirds had been leased at a rent of about 2*s.* per acre, and one-third purchased at the low price of 1*l.* 8*s.* per acre. The afforestation of cheap land like this adds materially to the real wealth of the country, as the timber produced will be much more valuable than the poor grass, rushes, bracken, furze, and heather which now cover the ground.

Afforestation also provides a ready means of giving work to the unemployed during seasons of bad trade. In November last, 250,000*l.* was allotted to forestry from the Unemployment Fund; and in spite of the difficulty of organising and in many cases improvising forestry operations with unskilled labour, more than 4000 men were set to work. Landowners and corporations were induced to plant, by small grants which were unencumbered by any condition except that unemployed labour should be utilised. As a result about 11,000 acres were planted on private estates, and preparation was made for the planting of a further 11,500 acres in subsequent years, a notable addition to the woodland area of Great Britain.

The actual work of afforestation on the lands acquired by the Commissioners was restricted in the first year by the lack of young trees; but 7794 acres had been planted by the end of the second season. Large quantities of tree-seeds were imported and extensive nurseries established at convenient centres, the latter covering in September 1921 an area of 607 acres and carrying a stock of 111 million seedlings and 33 million

<sup>1</sup> Second Annual Report of the Forestry Commissioners: Year ending Sept. 30, 1921. (London: H.M. Stationery Office, 1922.) 1*s.* net.

transplants. The report gives detailed information in tabular form about the area, cost, and species of the various plantations and nurseries. The positions of the different State Forests and Crown Woods are indicated in a sketch map.

Four schools for apprentice woodmen have been established, where sixty men received training in 1920-1921. These are situated at Parkend in the Forest of Dean, Burley in the New Forest, Chopwell in Durham, and Beaully in Inverness-shire. Research was carried on by six members of the Commissioners' staff; experiments were made on the germination of seeds; on the protection of seed-beds from drought, frost, and weeds; on insect pests; and on planting procedure. Seventy-nine sample plots, scattered over England, Wales, and Scotland, were under observation in September 1921. These plots will be thinned and measured periodically, in order to provide data as to the rate of growth and the best methods of thinning plantations of the different species.

The report concludes with an interesting account of the drought of 1921. It caused great damage in England and Wales, the death-rate among newly planted trees being 35 per cent. It is satisfactory to note that the Commission's plantations formed in the previous year did not suffer to any appreciable extent.

### The Green Flash at Sunset.

*The "Green Ray" or "Green Flash" (Rayon Vert) at Rising and Setting of the Sun.* By Prof. Dr. M. E. Mulder. Pp. 141. (London: T. Fisher Unwin, Ltd., 1922.) 6s. net.

WHEN the sun sets behind a distant and clear horizon, its last rays disappear with an emerald green flash. The coloration is due to the refraction of light in our atmosphere by which the sun's image is raised through about half a degree, the elevation increasing from the red to the violet end of the spectrum. As the violet and—to some extent—the blue rays are absorbed by the layer of air through which the light has to pass, it is the bluish-green part of the spectrum that is dominant at the ultimate moment of sunset. This seems clear enough and even obvious. But there are always certain minds that distrust the obvious—not always to the disadvantage of science—and others which rebel against a commonplace explanation of a striking effect. Imagination is always ready to supply more or less fanciful alternatives leading to controversies and correspondence in scientific journals.

In this manner a considerable amount of literature on the "green flash" has accumulated, and this is

now collected by Prof. Mulder in a volume of 140 pages. The book is readable and interesting. But the interest is mainly psychological, depending on the descriptions by which observers record their impressions and on their knowledge of the conditions under which the green flash appears. The two serious alternative explanations that have been offered to replace the one based on the dispersion of light in our atmosphere might be dismissed in one sentence. The green flash cannot be the after-image in an eye fatigued by the red light of the sun, because it appears at sunrise, as well as at sunset; nor can it derive its colour from actual passage through the sea, because it is also seen when the sun disappears behind a land horizon.

The author aims at giving us a complete account not only of everything that *can* be said on the subject, but of everything that *has* been said on it. We are told how observers have put their impressions into words and find transcriptions of a large part of the correspondence that has appeared in NATURE, in the Journal of the British Astronomical Association, in the *Meteorologische Zeitschrift*, and in other publications. The same arguments are repeated over and over again, until we feel that a horse dead and duly flogged had better be buried; this might save us from being worried by its ghosts and reincarnations.

Nevertheless, the account has its value as a chapter of scientific history. We note with interest that the first printed description of the green flash that can be traced is contained in a novel by Jules Verne entitled, "Le Rayon Vert," and published in 1882. Perhaps some readers of NATURE can verify the *Leit-Motif* of the story, taken apparently from a Scotch legend, according to which those who have once seen the green ray acquire the power of seeing what is in the hearts of others as well as in their own.

I first noticed the green flash in February 1875 on several successive mornings at sunrise while traversing the Indian ocean. The appearance was so striking and the explanation seemed so obvious that I took it for granted I had only witnessed a common and well-known phenomenon. In July 1878 during a passage to the United States I directed the attention of several members of an eclipse expedition to the appearance at sunset; among them was Mr. Cowper Ranyard, whose subsequent views on the subject are quoted with approval by Prof. Mulder. I still failed to realise that the effect had never received the attention of scientific men, though I understand that astronomers were familiar with the fact that the light of a star near the horizon is drawn out into a vertical spectrum.

If the author's investigation of the scientific literature is as exhaustive as it appears to be, the first scientific notice of the green flash was published only in 1885,



when Chevreuil communicated to the French Academy observations made in the Indian Ocean by Trèves, who adopted the erroneous theory of complementary colours. The reader must be referred to the book itself for the subsequent discussion. Some praise should be given to the author for the manner in which he keeps up the interest of his account and the fairness with which he recites the arguments of different writers. According to his own view a complete explanation is still wanting, although he agrees that it must be based on the dispersion theory. But I would suggest that his reservations depend almost entirely on the importance he attaches to discrepancies in the descriptions by different observers and in their estimates of the duration of the flash. Apart from real differences in atmospheric conditions that may be very considerable, it is not to be expected that men, not specially trained in such observations, could tell with any degree of certainty whether an outburst of light lasts a tenth of a second or two seconds. Some have described the flash as appearing in the form of a short line, while on others it has left no impression of shape. The author, who has been a professor of ophthalmology, is not likely to have forgotten the possible effects of astigmatism, but even a perfect eye might see a point of light drawn out into a vertical line if the eyelids have been partially closed to screen them from the glare of direct sunlight. When seen through a telescope the appearance seems to be much more regular, the green coloration first appearing at the corners of the cusp that remains above the horizon. There seems no reason to doubt that dispersion combined with absorption of light completely accounts for the effect.

Is it not time that the green flash should find its place in elementary text-books? It is eminently suitable for them, and only by this means shall we be saved from further discussions covering the same ground.

ARTHUR SCHUSTER.

### Village Communities.

*The English Village: The Origin and Decay of its Community. An Anthropological Interpretation.* By Harold Peake. Pp. 251. (London: Benn Bros., Ltd., 1922.) 15s. net.

SEEBOHM in 1883 issued his well-known work on the English village community, which he examined in its relation especially to the manorial system and to common field husbandry. Among the general conclusions of his work was the view that "neither the village nor the tribal community seems to have been introduced into Britain during a historical period reaching back for 2000 years at least; . . . the village community of the eastern districts of Britain was

connected with a settled agriculture which, apparently dating earlier than the Roman invasion and improved during the Roman occupation, was carried on, at length, under the three-field form of the open-field system which became the shell of the English village community." Without following out the discussion of Seebohm's views it may be said that the accumulation of archæological evidence since his day has made far more probable his view that there were agricultural settlements on cleared forest lands in Britain well before Roman times. The mapping of the catalogued Iron-Age finds from the lists given in the report on the Glastonbury Lake Village would furnish presumptive evidence on this point. It is, however, clear that Seebohm attributed great importance to Roman influence, which he says "enforced the settlement and introduced . . . fixed rotation of crops" "within the old Roman provinces (N. of the Alps) and in the Suevic districts along their borders," the area of "the geographical distribution of the three-field system."

In Seebohm's work there are frequent indications of his feeling out towards what was then the almost uncharted background of pre-history. It is the great merit of Mr. Peake's work that he has used his rich archæological knowledge as well as his historical reading in order to reach back beyond Seebohm. His interest is not in any question of origins of manorial organisation, but rather in the attempt to make the much-needed link between archæology and documentary studies for Britain. That this is one of the prime needs of our time admits of no question, and it is advisable that specialists on both sides should treat with special consideration pioneers who, like Mr. Peake, are trying to find the much-needed links.

For Mr. Peake the germ of the village community is to be found among the Neolithic agriculturists of the Swiss and Alemannic and Bavarian regions north of the Alps and is a social characteristic of the dark, broad-headed Alpine Race in those areas. He also suggests their domination by Nordic men of the Bronze Sword, but leaves the fuller working out of this subject to a companion-book to be issued shortly. These warriors set out about 1200 B.C. to dominate a large part of Europe and reached Britain within less than a century, as there is but very little difference in the types of sword found along their routes. Their followers were cultivators, and from evidence of bronze-sickles, of ploughs as substitutes for hoes, and of bronze axes in plenty, some late ones of which undoubtedly tell of forest-clearing, Mr. Peake believes they spread, at any rate, the germs of the village community in cleared forest areas. The landing of these people at Chelsea and Brentford as well as up the East Anglian Ouse

gives a clue to their access to the parts of England where the three-field system is best shown. That they did not at once dominate the west is clear from archaeological evidence, especially from the finding of rapier-like dirks in place of leaf-shaped swords in the south and south-west. In Wales and other hill-lands the moorland-village seems to have survived, and, when valley clearing spread there, family groups in single households moved downhill and built the Tyddyn near shelves of cultivation on the hill-sides. Mr. Peake thinks the Romans met the valley-village-community in Gaul and Alemannia and probably interfered with it as little as possible, so that according to him, the continuity from earlier times would be much greater than Seebohm thought. This is a view which obviously needs further examination on the basis of study of geographical distributions and we specially need maps of the distribution of open-field villages in France. Mr. Peake's view is, at any rate, far more helpful than the one which would ascribe the three-field system to the Saxon invaders of Britain, for these last came from a region where the one-field scheme was characteristic and they had little connexion with the Alemannic areas of distribution of the three-field system.

Having outlined this interesting opinion Mr. Peake follows, on fairly orthodox lines, the open-field valley-village down to its decay. He accepts the general view that diminution of fertility of the land was a factor of this decay, though that is now disputed and it is thought that the properly-organised folding of stock pastured on uncultivated lands would bring in enough manure. That this organisation was adequately maintained everywhere in view of competing claims for the manure between lord and tenant is, however, very doubtful, so the view in this book is probably not very far from correct.

Mr. Peake's years of public work in rural England give a special interest to his concluding chapter, which asks, what of the future? He sees that the old village is dead or dying from loss of internal cohesion and that there is too much tendency towards occupational as against neighbourly cohesion. He also fears the further urbanising of the people if the Garden City idea, which he admits to be the best urbanism, spreads. He thinks the Saxon village may have had less than 100 people, the mediæval village perhaps nearly 200, the modern survival about 200, more or less. As civilisation developed in classical lands villages fused, and there is, according to Mr. Peake, much need of larger units, especially for shopping and amenity purposes. The village has been losing its people, especially the best, at an alarming rate, but the tide of numbers turned a little after 1900 in several districts,

thanks probably to the motor car and cycle. To redeem village life from dulness Mr. Peake thinks a population of about 1000 would be desirable, and that in such a unit most standard occupations could be represented, an important factor of contentment now commerce has enlarged our needs. He pleads for farm buildings around the outskirts of the village so that the labourer may be near his beasts, and for small holdings in the outer ring of the village. A village of 1000 can have a doctor, a lawyer, a bank, a bootmaker, a builder, a carpenter, a reasonable school, a public hall, and a few shops of some value. Such villages would encourage retired people, maiden ladies without specialised occupation, and so on to settle in them, and might well lead to a redevelopment of handicraft at all events in leisure time.

The detailed suggestions may raise dispute, but what is of value here, besides the long and intimate working-experience of rural life which the author possesses, is the fact that the present unfortunate tendency towards separatist specialism is avoided. It is seen that small holdings *per se* are not enough, and that the settling of wage-rates or drafting of housing schemes is only a partial help. It is Mr. Peake's desire to start from life, and from the provision of opportunities of healthy exercise of varied faculties, that marks out his book as worthy of careful and earnest consideration.

H. J. F.

### Climbing Palms and the Sago Palms.

*Annals of the Royal Botanic Garden, Calcutta.* Vol. 12. Part 2: *Asiatic Palms—Lepidocaryæ.* Part 3: *The Species of the Genera: Ceratolobus, Calospatha, Plectocomia, Plectocomiopsis, Myrialepis, Zalacca, Pigafetta, Korthalsia, Metroxylon, Eugeissona.* By Dr. Odoardo Beccari. Text, pp. vi+231+6 plates. Plates, 120, size 21 in. × 14 in. (Calcutta: Bengal Secretariat Book Depot, 1918-1921.) Rupees 40; 3l.

IT is a matter of great regret that the late Prof. Beccari did not live to see the publication of the final part of his fine memoir on the Asiatic Lepidocaryæ, which he had very fittingly dedicated to the memory of the late Sir George King, the founder of the *Annals of the Calcutta Botanic Garden.*

It was characteristic of Sir George that he selected the proper people to prepare the valuable memoirs that have preceded the one under review, though his own contributions are among the most noteworthy of the series. This present part constitutes the third of Prof. Beccari's memoirs on the Lepidocaryæ, vol. xi. having been devoted to the important genus *Calamus*, and vol. xii., part 1, to the genus *Dæmonorops*. Like

its predecessors, the present part is accompanied by a magnificent series of plates and analytical figures of the flowers and fruits of the various species, which very materially enhance the value of the memoir.

The genus *Ceratolobus*, which is confined to the Malay Peninsula, Sumatra, Java and Borneo, consists of six species, four of which are described by Beccari. Three of these four are found in Borneo and two in the Malay Peninsula—one of the later, *C. laevigatus*, Becc. having six varietal forms spread over the Malay Peninsula, Sumatra and Borneo. *Calospatha Scortechinii*, collected by that assiduous botanist, Father Scortechini, in Perak, and described by Beccari, comes next on the list and is an interesting and very distinct palm, having a homogeneous albumen in the seeds, two to three in a fruit. In the genus *Plectocomia*, which are large, spinous, calamoid palms with terminal inflorescences, six new species are described. One of these, *P. Kerrana*, was discovered at Doi Soetep, near Chiangmai, Siam, by Dr. Kerr, who has made known to us the riches of the Siamese flora by his admirable collections in that country.

*Plectocomiopsis* is a new genus described by Beccari, containing five species, from Lower Burma and throughout the Malay Peninsula and Sumatra, and is again a calamoid, dioecious genus allied to *Myrialepis*, Becc. In its vegetative organs it resembles *Plectocomia*, though it differs widely in the spadices and flowers. Beccari then passes to the genus *Zalacca*, a characteristic and exclusively Indo-Malayan group containing thirteen species, denizens of rich, deep and moist soil in the recesses of primeval forests. The home of *Z. edulis*, which is frequently cultivated for its edible acid fruits, is not definitely known, but it is considered to be a native of the Malay Islands. It has been known since the time of Clusius, who examined fruits of this palm sent over from Bali in brine about 1600. Two new varieties of this species are described, and six new species by Beccari; of the latter, *Z. dubia* is only certainly known from the male flowers.

The genus *Pigafetta* described by Beccari was regarded by Martius as a section of *Metroxylon*, the sago palm, but Beccari proves that it is a distinct genus by its polycarpic nature. It is not closely allied to any other genus of *Lepidocaryae*, and is a tall tree with dioecious, axillary spadices and small calamoid fruits. It is due to these small fruits, no doubt, which are eaten by birds, that this palm, *P. filaris*, has so wide a range in the Moluccas, Celebes, New Guinea and Indo-China.

The next genus dealt with, *Korthalsia*, is again a genus of climbing palms containing twenty-six species, mainly Malayan. They are of economic use as, being very tough, the naked canes are used for tying, etc., by

the natives; they are also of interest in being myrmecophilous, with the appendage at the mouth of the leaf sheath (the ocrea) largely developed and sometimes transformed into a closed ant nidus. Extra-floral nectaries are also developed in the axillæ of the leaflets.

*Metroxylon*, the sago palm, and *Eugeissona*, one species of which, *E. utilis*, Becc., also yields a sago flour, complete the Asiatic *Lepidocaryae*, and the part is concluded with an enumeration of the extra Asiatic palms belonging to this family, among which *Raphia* and *Mauritia* are perhaps the best-known genera.

The genus *Metroxylon* contains six species with numerous varieties, and the account of these valuable palms occupies nearly forty pages of the memoir. They are arborescent palms with a terminal inflorescence, and the two best-known species are *M. Rumphii* and *M. Sagus*, which are widely cultivated in the Moluccas, for the sake of the starch or sago flour extracted from the stem. Both these palms yield many other commodities used by the natives. Prof. Beccari considers the Moluccas to be the home of these two species, and especially the island of Ceram, where a new species, *M. squarrosus*, Becc., has been found in abundance at the east end. Owing to their importance in affording food to the natives, they have now been carried far and wide.

To appreciate the value of this work it must be studied in detail, and all students of palms and botanists generally will realise how much they have lost by the death of Prof. Beccari, who was the pre-eminent authority on palms.

A. W. H.

### The Control of Electric Power.

*Switching Equipment for Power Control.* By S. Q. Hayes. Pp. vii+463. (New York and London: McGraw-Hill Book Co., Inc., 1921.) 20s.

SOME of the most important problems with which the engineer of a large power station has to deal are in connexion with the switches and control apparatus of his distribution system. Information on this subject can be found in a very condensed form in several text-books, but there is a demand for more detailed information, and in particular there is a great demand for a definite statement of the physical principles on which many of these devices are supposed to act. In Mr. S. Q. Hayes' book detailed information is given of many types of switchgear of American manufacture, but as a rule the descriptions are similar to the descriptions we get in manufacturers' catalogues, and in some cases they are actually taken directly from these catalogues. The author is one of the leading experts on switchgear, and occasionally

the reader is gratified by a brief description of the theory on which the device is founded, but in many cases no hint is given.

In our opinion the value of the book would be very greatly increased by additional brief descriptions of the physical laws which govern the action of many of the devices used by engineers. For example, a table of the rating factors by which the voltage of a given circuit breaker must be multiplied so as to get its rating at various heights above the sea level is given. It would be useful to give the theory used by the General Electric Company of America in getting these numbers.

Many types of the spark gaps used in practice are given, and it is pointed out that the sphere gap has a greater speed of discharge than the horn gap. The "impulse gap," which we believe was perfected during the war in connexion with the spark gap used in the magneto circuit of an aeroplane, is now adopted for lightning arresters. The Westinghouse Company state that it is more efficient than any other spark gap. An investigation of the action of the lightning arresters described would be a very promising field of research for the pure physicist.

In reading this book one gets accustomed to the American words "resistor" and "reactor" which are used for "resistance" and "reactance coil" respectively, and these words might well be adopted in this country. Electrical engineers talked about "omnibus bars" thirty years ago, it then became "bus bars," and now apparently it has become "busses." This book will be useful to the switchgear expert.

A. R.

### A Modern Text-book of Chemistry.

*Inorganic Chemistry.* By Prof. T. M. Lowry. Pp. xi+943. (London: Macmillan and Co., Ltd., 1922.) 28s. net.

FIFTY years ago there were no books on physical chemistry. The work which had been done on the borderline of physics and chemistry was scattered in different journals and was not readily accessible to the student. The first volume of Miller's "Chemistry," Tilden's "Chemical Philosophy," and certain articles of the old Watts's "Dictionary" were the first available summaries of what is now one of the most important branches of the subject. The works of Lothar Meyer and Ostwald, published in the late 'seventies of the last century, did much to direct attention to the importance of physical chemistry. The first professor of physical chemistry was appointed only twenty-five years ago, and even now this branch of the subject is still allotted to a lecturer at some of the universities in this country.

It is now recognised that inorganic and organic chemistry will become a mere record of facts, the interpretation of which, without the aid of physical chemistry, will remain undisclosed. It is therefore a matter of congratulation to the publishers that they should have been able to arrange for the publication of a book on inorganic chemistry by a physical chemist. The author is also to be congratulated on the way in which he has fulfilled his task. Perhaps the severest test of such a book is to refer to all the parts of the work which one knows are stumbling-blocks to the ordinary intelligent student. Prof. Lowry's book stands this test remarkably well; in one case alone, the liquefaction of gases, will the information need to be supplemented by the teacher. If it had been possible to give the references to original papers the book would have sufficed for any chemist who was not intending to devote himself to inorganic chemistry as his main subject, although the author in his preface seems to disclaim the use of his book as a book of reference.

The book is admirably produced, and the illustrations are remarkable, no less for their number than for their clearness. The book may be heartily recommended.

H. B. BAKER.

### Our Bookshelf.

*Drahtloser Übersee-Verkehr.* Von Dr. Gustav Eichhorn. Pp. 69+xx. (Zürich: Beer et Cie, 1921.) 7 francs.

In the first two chapters of the publication under notice, an excellent description is given of the great German radio-station at Nauen and of the receiving station at Geltow, twenty miles south of it. The third chapter discusses the theory of thermionic tubes, and the method of indicating the paths of the various currents by marking them in different colours is to be commended. The last chapter on radio-telephony is concerned mainly with modern German practice. In the Appendix a few well-known papers by Howe, Vallauri, etc., are published. The book is clearly printed, and the photographs of the Nauen station and the great lattice towers with their networks of wires show on what a huge scale it is designed.

During the last few years the station has been practically redesigned. The standard system of transmission does not yet seem to have developed. For example, they are at present constructing seven new towers, each 210 metres high, to enable them to communicate with Argentina. Under favourable atmospheric conditions the Telefunken Co., who own the station, have maintained communication with Japan for several years, although the messages have to go overland across Europe and Asia. The antennæ can be separated into four separate sections, each of which can be attached to a separate transmitter. When weather conditions are adverse all the antennæ can be connected in parallel. They then have a joint capacity of 0.01 microfarad. The two largest sections are each

connected with 400 kw. high-frequency alternators through two or three frequency doublers connected in cascade. The smaller sections are connected to smaller machines. Although the antennæ are close they can be operated quite independently of one another.

Dr. Meissner, the engineer-in-chief, hopes to reduce the earth-resistance of the antennæ to a fraction of its present value. How much this resistance lowers the efficiency can readily be seen by the figures given in this book. For example, in one case the effective current in the antennæ is given as 360 amperes and its resistance is 2.7 ohms. We learn that radio-telephonic systems are now established between Munich and Frankfort and between Berlin and Hamburg.

*Phytopalæontologie und Geologie.* Von Prof. Dr. W. Deecke. Pp. iii + 97. (Berlin: Gebrüder Borntraeger, 1922). 6s. 3d.

PROF. DEECKE'S essays on broad questions of geology always provide interesting reading. The present work is perhaps unduly sceptical; but its stimulus to further comparison and correlation is based on careful reasoning. While mention is made of the importance of plants as rock-formers, the main thesis is their value for geologists as indicating topographic and climatic conditions in the past. The author shows how vegetation growing on cold uplands may become entombed in the downwash from mountain-sides, and he strongly opposes the notion that the flora of a sheltered Miocene marsh at Ceningen may be used as an illustration of the contemporaneous flora on the Swabian Alb. Even the beautiful theory that the occurrence of rings of growth in fossil trees indicates an orderly recurrence of seasons, while their absence indicates a uniform climate, comes in for useful criticism. Though the author states the importance of calcareous algae in forming Carboniferous limestones and, aided by their magnesium, Triassic dolomites, we miss a reference to the Cryptozoon question. This is a mere petrographic detail in the general discussion, which leaves us with the impression that geology, including the determination of local conditions of plant-growth, may be of more service to paleophytology than phytopalæontology can be to geology.

G. A. J. C.

*Practical Mathematics.* By A. Dakin. Part I. (Mathematical Series for Schools and Colleges.) Pp. viii + 362 + 12 + xxiv. (London: G. Bell and Sons, Ltd., 1921.) 5s.

THERE should be a considerable demand for Mr. Dakin's book, as it contains just the sort of mathematics that is required by those who have to learn some elementary mathematical processes for practical use: decimals, mensuration and a few other topics in arithmetic, algebraic formulæ and equations, graphical methods, the geometry of rectilinear figures, similar figures, the circle and the sphere, with some numerical trigonometry. The treatment is very pleasant, and the student who uses the book will certainly fail to experience the aridity that the popular mind associates with mathematics. Mr. Dakin's account of graphs is particularly good; the introductory portion with the comparison and correlation graphs cannot but grip the student's interest, and

make him feel that the method of graphs is worth acquiring. Historical notes are incorporated in the main text, and occasionally they are worked in very skilfully. Presumably the tables are given the title "logarithmic tables" from force of habit: they contain only natural trigonometrical ratios.

If the second part maintains the high standard of the present volume, the author will have added a valuable treatise to available books on the subject. It is to be hoped it will not suffer the fate of so many sequels.

S. B.

*Cours complet de mathématiques spéciales.* Par Prof. J. Haag. Tome 2, Géométrie. Pp. viii + 661. (Paris: Gauthier-Villars et Cie, 1921.) 65 francs.

THIS is the second part of Prof. Haag's complete treatise on pure mathematics as required by the ordinary student specialising in mathematics. The first part dealt with algebra and analysis: the present volume is geometrical in the widest sense. We thus have analytical and synthetic geometry in two and in three dimensions, all treated simultaneously. A correct description of the book is therefore to call it a compendium of modern methods in geometry; it contains a vast amount of information of a fundamental character, and makes excellent reading.

Contrary to usual practice, especially in this country, the author does not devote very much space to conics as such. Perhaps he is right in thinking that the general practice of making a long and detailed study of the curves of the second degree tends to endow them with an importance that their practical usefulness does not justify. On the other hand the methods of the calculus are used freely.

Exercises in illustration of the principles and methods are conspicuously scarce, and no examples are given for the student to work. One is led to wonder whether a student can derive any considerable benefit from reading mathematics like a novel.

*The Foundations of Æsthetics.* By C. K. Ogden, I. A. Richards, and James Wood. Pp. 95 + pl. I-XV. (London: G. Allen and Unwin, Ltd., 1922.) 7s. 6d. net.

THE aim of the authors of this short treatise on æsthetics, as stated by themselves, is to present in a condensed form the greater part of accredited opinion on the subject while relating it to the main positions of the theory of art criticism. The various theories are not brought into opposition, but are distinguished to allow to each its separate sphere of validity. Beauty is thus discussed as intrinsic, in relation to the medium, to mysticism, and to its social effects and the like. They themselves find the solution of the problem in synæsthesia, a term covering a state of equilibrium and harmony in which the percipient becomes more fully himself and at the same time is in sympathetic understanding with other personalities. Hence arises the educative value of art. This theory is acceptable so far as it goes, but, like much of the current theory of æsthetics, in describing the "how" it fails to answer the question "why," a matter in which the anthropologist, censured by the authors, may be able to assist, in view of the current vogue of non-European art.

*Cancer of the Breast and its Treatment.* By Prof. W. Sampson Handley. Second edition. Pp. xvii + 411. (London: Published for the Middlesex Hospital Press by J. Murray, 1922.) 30s. net.

IT is now more than six years since the exhaustion of the first edition of this book, in which Sampson Handley set out to place the operative treatment of cancer of the breast on a more rational basis by a closer study of the pathology of the disease. His main conclusions were: (1) that carcinoma spreads centrifugally by permeation of the lymphatic plexuses; (2) that reparative processes inadequate for cure are a normal part of the cancer process; (3) that inflammation and fibrous tissue formation are the principal of these defensive processes; (4) that invasion of the serous cavities is an event of critical importance in the process of dissemination; (5) that the embolic theory is only true for exceptional cases. The author instances much detailed evidence in support of these views, which have won widespread, though not universal, acceptance.

The present edition contains new chapters on radiological treatment, recurrence, Paget's disease of the nipple, lymphangioplasty, and injury as a causative factor in carcinoma. The book is well arranged and excellently illustrated.

*A Handbook of Some South Indian Grasses.* By Rai Bahadar K. Ranga Achariyar. Assisted by C. Tadulinga Mudaliyar. Pp. vi + 318 (Calcutta: Butterworth and Co., Ltd.; London: Constable and Co., Ltd., 1921.) 4 R. 8 As.

THIS book is intended to serve as a guide to the study of the grasses of the plains of South India for the use of officers of the Agricultural and Forest Departments and others interested in grasses. To remedy scarcity of fodder, foreign grasses and fodder plants have been imported, but so far none have been established on a large scale. The same amount of attention bestowed on indigenous grasses would have yielded better results. About one hundred grasses of wide distribution in the South Indian plains are described in this volume. The arrangement adopted is that of the "Flora of British India." Keys for the identification of genera and species are given, and good descriptions of each species are accompanied with figures of the whole plant and of the spikelet and details of the flower. The descriptions are preceded by a useful general account of the vegetative organs and flowers, and the histology of the stem and leaf. The figures, though not always quite sharp, are sufficiently clear to be a great help towards the identification of a given specimen. The handbook should prove of good service in South India.

*The World About Us: A Study in Geographical Environment.* By O. J. R. Howarth. Pp. 94. (London: Oxford University Press, 1922.) 2s. 6d. net.

MR. HOWARTH has written a small book on a most important subject. Its size is the only fault we have to find with this excellent volume, although it is a pity that a title more descriptive of the content was not chosen. Enthusiasm for the geographical point of view too often leads to exaggerated statements of the influence of environment on human activities and is prone to encourage generalisations which not infrequently ignore the facts. Mr. Howarth is too

careful a geographer to fall into these bad ways. He traces the nature of geographical influences, and in selected cases tries to estimate the forces of the factors involved. Chapters on the factors of environment are followed by others on distribution, migration, and transport. Particularly suggestive are the chapters on geographical environment and political states, and the local application of environmental study. The latter expounds the idea of regional survey in its value as a co-ordinating study of the things and peoples around us. Mr. Howarth's thoughtful and lucidly written volume should help geography to find its proper place in educational schemes. It deserves to be read widely.

*Eyes and Spectacles.* By Dr. M. von Rohr. Rendered into English by Dr. A. Harold Levy. Authorised translation. Pp. vi + 130 + xxii. (London: Hatton Press, Ltd., n.d.) 6s. net.

WE believe that this little book by Dr. Moritz von Rohr will prove as helpful to other English readers as it has been to the translator. Not only should it be read by those who prescribe and those who make lenses, but also by those who have to teach medical students or others the elementary principles on which the science of ophthalmology is based. The first part of the book deals with the eye itself, and also perspective as a form of perception by means of which the arrangement in space of the outer world becomes manifest to the observer. The most important section of the book deals with spectacles, and stress is laid on the two fundamental problems of increased clearness of vision and the alteration of direction of the object perceived. The final portion of the volume deals with spectacle frames. The translation, which has had the advantage of the author's revision, appears to have been carried out in an efficient manner.

*The Link between the Practitioner and the Laboratory: A Guide to the Practitioner in his Relations with the Pathological Laboratory.* By C. Fletcher and H. McLean. Pp. 91. (London: H. K. Lewis and Co., Ltd., 1920.) 4s. 6d. net.

THIS little book is for the guidance of the medical practitioner when he is obtaining the assistance of the laboratory. It enumerates clinical conditions with the appropriate pathological investigations, and gives clear instructions for the collection and transmission of the necessary material; there is also a brief résumé of vaccine and serum therapy. Attention to the details given will certainly assist the practitioner in supplying to the pathologist the right material in the right way.

*Émile Coué: The Man and his Work.* By Hugh MacNaughten. Pp. xi + 52. (London: Methuen and Co., Ltd., 1922.) 2s. net.

AN ambitious title appears on this book, which is really an enthusiastic appreciation of a doctor from whom the writer has received benefit. It records vividly scenes at Nancy, Eton, and London when Coué gave demonstrations of his methods. The writer gives a very charming impression of Coué as a man. The book is not, however, nor does it purport to be, a scientific treatise on Coué's theories of suggestion.

Letters to the Editor.

[The Editor does not hold himself responsible for opinions expressed by his correspondents. Neither can he undertake to return, or to correspond with the writers of, rejected manuscripts intended for this or any other part of NATURE. No notice is taken of anonymous communications.]

Capillarity.

IN Mr. W. B. Hardy's excellent "Historical Notes upon Surface Energy and Forces of Short Range" in NATURE of March 23, vol. 109, p. 375, he remarks that "the exact way in which the attractive forces act in causing the rise of fluid in capillary tubes and the spreading of fluid over solid and fluid surfaces is still obscure." He evidently rejects all explanations by any Laplacean conception of molecular attraction. He probably holds that the explanation is to be sought in the modern electric theory of the constitution of matter, but that this theory has not as yet been developed far enough to throw sufficient light on the question. By the use of the term "attractive," however, he restricts the inquiry to a limited class of forces in terms of which these phenomena are to be explained. It is just possible that this restriction may preclude the solution of the problem.

That it is possible to conceive of a force which cannot be put in this class of "attractive" forces of short range may be shown. If a mass consisting of a single molecule exists at all, it has a position in ether-space at some particular instant. It may be considered isolated from all other masses. There is, therefore, a closed boundary within which there are properties differing from those not within this boundary. Any part of this closed boundary may be conceived as an area between space-regions called "mass" and "no-mass." If we say that *this enveloping area tends to become less*, we have defined a "force" which cannot be included in the class of attractive forces. Further, if we say that, *when two such enclosures come into contact, the tendency to decrease does not exist in the area of contact*, since there is no distinction of properties on opposite sides of this area, we have defined the law of the "force" for like masses. Finally, if we say that *when the two masses are unlike there is this distinction of properties and, consequently, a tendency of the common area to decrease*, we have extended the law to unlike masses. Space will not permit the elaboration of these conceptions.

The question is: Does this "force" as conceived above really exist? Whether it does or not, repeated applications of the law as stated will account for surface tension of visible liquid and solid surfaces in terms of it. It will be admitted that the phenomenon of coalescence of visible spheres of like liquids is a direct application of the law. Also, in his letter on "Cohesion" in NATURE of January 5 (vol. 109, p. 10), the present writer has shown experimentally that visible exterior cohesion and adhesion in solids and liquids may be accounted for by surface tension forces alone, and, consequently, may be explained by molecular (surface) tension. Now these and even capillary-rise and fluid-spreading might conceivably be explained by intermolecular electric forces, though this has not yet been done; but it is difficult to see how the latent heat of a gas can be so accounted for, since in a gas the molecules are too widely separated to admit of short range intermolecular action at all, and the condensation of a gas, by which alone this great amount of heat is made available, is unattended

by any chemical change or electrical effect. This latent heat, however, may be fully accounted for by molecular surface tension, as the writer has shown in the *Phil. Mag.* v. 41, p. 877.

Either, then, the latent heat of a gas must be otherwise accounted for, or the existence of molecular surface tension must be admitted. This in turn, it is true, may eventually be explained by the action of electric forces in the interior of the isolated molecule. In the meantime the writer offers the following explanation of capillary-rise and surface-spreading in terms of molecular tension as conceived above.

The following phenomena are illustrative. (a) If two free spheres of immiscible liquids be brought into contact, the mass of the one suddenly proceeds completely to envelop the mass of the other. (b) If a free liquid sphere and a small solid which does not dissolve in the liquid be brought into contact, one of two actions takes place: either the mass of the liquid forms a closed sheath about the solid, or the mass of the solid tends to envelop the liquid, but is prevented by internal cohesion from assuming the necessary form. The liquid then stands out as a curved mound on the solid with a distinct "capillary" angle. With water mercury acts as a solid metal. It is on this differential action of this surface force of water

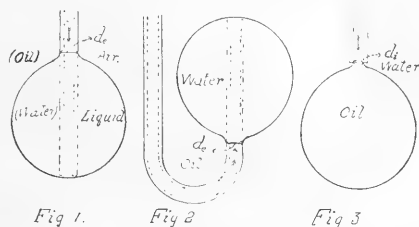

in union with those of small particles of minerals and rocks that the flotation processes for mineral separation depend.

When a liquid is in contact with a solid, there are three areas in which this tendency to decrease exists in different degrees, namely, the liquid-air, the solid-air, and the solid-liquid areas, the sum of the latter two areas being constant. At contact the only possible way in which these latter two tendencies can result in action is to decrease the solid-air area from its maximum by increasing the solid-liquid area from zero. Experiments show (NATURE, *ibid.*) that this change always proceeds to some extent. In the case of water and rock it proceeds until all the solid-air area becomes solid-liquid area. It does not reach this limit in the case of water and a mineral.

But the extent of this fluid-spreading depends further on (1) the tendency to decrease of the liquid-air area, unrestricted by internal cohesion, (2) the force of gravity acting on the liquid mass, (3) the form of the solid area, and (4) the amount of the liquid. Thus, a small drop of an oil such as oleic acid may not spread far on a horizontal glass surface, since the decrease in the glass-air area involves increases in both glass-oil and oil-air areas; whereas in capillary-rise this decrease does not involve any increase in oil-air area. The oil will, therefore, ascend until its increasing weight balances the tendency to decrease (tension) in the glass-air area within the tube. Again, a hanging drop of the oil will completely envelop a large fragment of glass and hold it against its weight.

It is plain, then, that methods of measuring surface tensions of liquid-air and liquid-liquid areas should

be, so far as possible, free from errors arising from unknown changes in liquid-air areas and from the unknown solid-air and solid-liquid tensions. It will be seen that the capillary-rise method in reality does this, though there is difficulty in measuring the internal bore and keeping it clean. But the following arrangement seems to be as nearly as possible free from these objections, and to be adapted to measure the tensions of interfacial liquid surfaces as well.

The liquid (mercury excepted) is made to drop from a fine capillary tube having thin walls as in Fig. 1. In forming the drop, it spreads upward over the exterior surface and reaches a limiting size, shape, and position. It then slips down the tube at a uniform velocity with little modification in size or shape, and after suffering a slight check in its motion breaks its connexion and falls. We may then equate the whole tension about the tube with the weight of the drop, so that  $T_{ia} \times \pi d_e = W_L$  or  $T_{ie} = W_L / \pi d_e$ , where  $T_{ia}$  is the liquid-air tension and  $d_e$  is the external diameter of the tube.

The same drop formation occurs when the tube is arranged to drop water downwards in any lighter oil, or by a bent tube (Fig. 2) upwards in a heavier oil. In this case we have the equation  $T_{eo} = \frac{W_o}{\pi d_i} \times \frac{\rho_o - \rho_w}{\rho_w}$ , where the suffixes  $w$ ,  $o$ ,  $e$ , and  $i$  denote the words water, oil, external, and internal, and  $\rho$  is density, from which the tension of the water-oil surface may be calculated.

On the contrary, when oil is dropped either downwards or upwards in water, it does not spread on any exterior water-glass surface, but forms its attachment as in Fig. 3. In this case we have  $T_{eo} = \frac{W_o}{\pi d_i} \times \frac{\rho_o - \rho_w}{\rho_o}$ .

These all give results agreeing with those recorded in the standard tables.

In accordance, then, with this conception of an elemental force not included in the class of "attractive" forces, we should expect that these changes in area would be always attended by a rise in temperature. If it be asked why the enveloping area about a free molecular mass tends to decrease, there is no answer; and neither is there an answer to the question as to why a large mass tends to approach another.

WILSON TAYLOR.

Physics Laboratory,  
University of Toronto, Canada, July 15.

### The Influence of Science.

THE seeming contradiction in my summary account of the case of Galileo (NATURE, August 5, p. 180), to which Sir Oliver Lodge directs attention in his letter (NATURE, August 26, p. 277), needs an explanation. The great work of Copernicus (1543) was dedicated to a Pope, Paul III.; none of the Roman Congregations found any objection to it, and (Whewell, "History of the Inductive Sciences," I. 418, ed. 1847), says "lectures in support of the heliocentric doctrine were delivered in the ecclesiastical colleges." This was because of its being taught as a purely scientific doctrine.

Sir Oliver writes that Galileo "had endeavoured to get the Church to realise that the doctrine was not really antagonistic to Scripture when reasonably interpreted." This statement needs qualifying. Had Galileo contented himself with teaching the Copernican doctrine as a scientific hypothesis, he would not have been molested. But, being a fierce controversialist, he wanted to confound his many adversaries, the mathematicians, and the Aristotelians, by showing that Scripture was on his side (cp. Sir David Brewster, "Martyrs of Science," p. 58). Hence,

disregarding the advice of the Bishop of Fermo "not to raise the question," and that, too, of many other ecclesiastical friends, among them Cardinals and Prelates, to the same effect, he demanded that "the Pope and the Holy Office should declare the Copernican system to be founded on the Bible." *Hinc illae lacrymae.* On the other hand, the attitude of the Churchmen is well illustrated in a letter from Cardinal Bellarmine to the Carmelite friar, Foscarini, one of Galileo's friends, dated April 12, 1615. He writes: "If a true demonstration should be found that the Sun is placed at the centre of the world, and the Earth in the third heaven, and that the Sun does not turn round the Earth, but the latter round the former, then it will be necessary to proceed with great prudence in the explanation of Scripture, which seems to say the contrary, and rather to avow that we have not understood it, than to declare a demonstrated fact false." Astronomers had to wait until the discovery of aberration by Bradley before such a true demonstration was found.

Sir Oliver also writes that "Galileo was made to recant, to abjure, and curse the theory of the earth's motion." Whewell tells us (*loc. cit.*, p. 419), "He (Galileo) was accused before the Inquisition in 1615, but at that period the result was that he was merely recommended to confine himself to his mathematical reasonings upon the system, and to abstain from meddling with Scripture." After his contempt of court, in the second trial, of the year 1632, he was condemned as "vehemently suspected of heresy." He was sent to Arcetri, and had to recite a penance of certain prayers.

There was no implication in my former letter, as Sir Oliver writes, "that there was really no punishment, and that there was no call for anxiety and distress." The implication was that his troubles were largely, if not entirely, of his own seeking, and that his treatment was, according to the quotations I gave from Whewell, and from De Morgan, comparatively mild. I purposely quoted from non-Catholic writers, as they cannot be suspected of partiality towards the Roman Congregations. To these I add the testimony of Sir David Brewster (*loc. cit.*, p. 88): "During the whole of the trial Galileo was treated with the most marked indulgence." Sir Oliver Lodge's quarrel is, therefore, with such eminent scientific men as Whewell, De Morgan, and Brewster (see also *op. cit.*, p. 77), to whom we may add Huxley, who ("Life and Letters," ii. 424) avowed that "the Pope and the Cardinals had rather the best of it."

But my chief implication was, and is, that the case of Galileo cannot fairly be considered as evidence of the hostility of the Church to natural science, and as a hindrance to her legitimate influence. Finally, I trust Sir Oliver Lodge will not think me discourteous in not treating of the other points raised in his letter, as I do not consider them to be relevant to the present discussion.

A. L. CORTIE, S.J.

Stonyhurst College Observatory,  
August 31.

### The Production of a Standard Source of Sound.

I HAVE recently had occasion to consider the problem of constructing a simple standard source of sound, and have been favourably impressed by the possibility of employing a "hot wire" grid—as used in the Tucker microphone (Phil. Trans. A, vol. 221, pp. 389-430)—for this purpose. In this microphone the grid is made of fine platinum wire and heated by a current of 20-30 milliamperes. It is mounted in the orifice of a Helmholtz resonator, and when the latter is stimulated by a sound of suitable pitch, the vibration of the air in the orifice causes an increase



in the average rate of loss of heat by convection, and consequently there is a fall in the temperature, and hence in the resistance, of the grid. The fall in resistance can be measured by a Wheatstone bridge method. The way in which it is suggested that this process may be utilised in the construction of a standard source of sound is as follows. The source is made in the form of a cylindrical Helmholtz resonator—say from brass tubing about 2 in. diameter. At one end is fitted a telephone in such a way that the diaphragm forms part of the inner wall of the resonator, while at the other end is the orifice carrying the hot-wire grid. If the telephone diaphragm is made to vibrate by current from a thermionic valve oscillator, and the frequency of the current is adjusted until it is equal or nearly equal to that of the resonator, a pure tone of moderate intensity issues from the orifice. At the same time the hot-wire grid suffers a change of resistance which provides a measure of the amplitude of the vibration in the orifice, and hence of the *strength* of the source. With a standard pattern grid and holder the change in resistance is about 12 ohms when a sound of pitch 200 vibrations/sec. is produced, which is loud enough to be just audible at a distance of 10 feet—the source being placed on the ground in the open. The strength of the source can be varied at will by using a variable series resistance or a shunt with the telephone. The use of resonance serves to purify the note which comes from the telephone, but it is desirable in addition that the oscillator should be of such a type that the telephone note is already fairly pure. The use of a very impure note may lead to poor results, as the resistance change will then depend only partly on the amplitude of the fundamental.

It may be noted that a simple method is known of obtaining the relation between the change in resistance of a grid and the amplitude and frequency of the vibration producing it—the motion being simple harmonic. Hence, if the frequency of the vibration is known, the strength of the source (defined as the rate at which fluid is introduced or abstracted at the source) can be found in absolute measure. The amplitude of the waves—or, if preferred, the flux of energy—in the surrounding medium can then be calculated in certain cases. A simple case is when the source is close to a rigid plane.

Any other means of producing a suitable sound can be used in place of the telephone diaphragm provided it is small enough to go inside a resonator. If the damping factor of the resonator has been determined experimentally, the acoustical output of the primary source inside the resonator can be calculated from the indications of the hot-wire grid in the orifice. The output of the internal source includes (1) the radiation of acoustical energy from the orifice, which has been dealt with above, and (2) work done against viscous forces in the orifice. Unless the orifice is large, (2) is far the more important part, and the radiation losses may be negligible by comparison.

E. T. PARIS.

Signals Experimental Establishment,  
Woolwich, S.E.18, Sept. 2.

#### Occurrence of the Rare Whale, *Mesoplodon Layardi*, on the Tasmanian Coast.

SOME years ago, on July 30, 1918, my friend Mr. G. H. Smith of Leprena, Southern Tasmania, brought me word that a beaked whale, "without teeth," had been cast up on the beach at Recherche Bay near his property, that he had already removed the blubber, and that the carcase still remained on

the shore. Being occupied at the time with university teaching I was unable to visit Recherche Bay till some weeks later. High seas were then running, and the remains had been lifted by these and thrown farther up on the basaltic boulders which strew the beach at this spot. This resulted in some considerable damage to the skeleton. Nearly all the ribs were broken, some into three or four pieces, and many of the neural spines had been smashed from the vertebrae. The skull was also damaged, although some of the flesh and integument was still adhering.

The body was naturally in a somewhat decayed and pulpy condition, but with Mr. Smith's help I was able to salvage the remains and so obtain the skeleton. This is almost complete and is now in my Department.

My friend was good enough to hand me some measurements and notes which he had made and these I reproduce. The animal "was a female whale. The total length was about 18 ft.; its jaws were 2 ft. 6 in. long, about 4 in. in diameter at the end, no teeth above the gums. Fins 2 ft. long, 8 in. wide, and tapered, not round like the black whale type. Its flukes were about 4 ft. wide; it had the appearance of a fast fish as it was rather thin in the body. There was a small fin on its hump, about a foot high, with a decided rake towards the tail. The colour the same as the sperm whale, dark grey and light underneath." Mr. Smith further states that the blubber yielded 50 gallons of oil of the finest quality, and that he believes that the animal was driven ashore by "killers," of which there were a number in the bay at the time. There were, however, no marks of injury on the body.

The matter of recording this specimen seems called for, particularly in view of the description by Mr. E. R. Waite, director of the South Australian Museum (Rec. S. Aus. Mus., vol. ii., No. 2), of the discovery, on the South Australian coast, of an immature male of this species of *Mesoplodon*. The Tasmanian specimen was a female and mature, as is witnessed by the condition of the skeleton and by the fact that the pulp cavity of the tooth is entirely closed below.

The form of the tooth corresponds exactly with that figured by Gray for his *Callidon guntheri* (Ann. Mag. Nat. Hist., 1871), which, as Flower and Turner suggested, was a female of the present species. It seems now that we must conclude from Waite's description that the mature condition of the tooth in the female represents a stage which is early passed through in the male.

No pelvic bones were discovered, nor was there any trace of the denticles found in the integument of the jaws of other species. The oil has a density of 0.88 at 12.5° C. This whale has now been recorded from the coast of every Australian State except Victoria and West Australia.

T. THOMSON FLYNN.

University of Tasmania, Hobart, July 20.

#### Atoms and Electrons.

ON the basis of any theory of atomic structure which classifies the elements according to rare gas type, cerium and thorium should be comparable with one another, since the atoms of each are possessed of four electrons more than those of the corresponding inert gases, xenon and niton respectively. There are, however, in the thorium atom, thirty-two more extra-nuclear electrons than in the cerium atom. In spite of this fact, it appears that the *distances between atomic centres in crystals of these elements are practically the same* (Ce = 3.62 Å.U. and Th = 3.56 Å.U., according to Hull), the distance being, if anything, slightly the

smaller for thorium. Both crystallise in the face centred cubic lattice. If the interatomic distances may be taken as representing atomic diameters, this means that in the same (or slightly less) volume there are concentrated in the thorium atom thirty-two more electrons than in the cerium atom, the total numbers in the two cases being, respectively, ninety and fifty-eight.

Thorium is the next to the last element in the periodic table possessed of particular stability. Between the last, uranium, and neodymium in the preceding period, a structural relationship exists similar to that between thorium and cerium. The crystal structures of these elements by the X-ray method have, unfortunately, not been worked out. However, an approximate idea of the relative sizes of the atoms of these substances may be gained by a comparison of their atomic volumes. According to Landolt-Börnstein's "Tabellen," the densities of neodymium and uranium are 6.96 and 18.7 respectively. Dividing the atomic weights (144.3 and 238.5 respectively) by these numbers gives for the atomic volume of neodymium 20.7, and for that of uranium 12.8. The corresponding quantities for cerium and thorium are about 20.5 each. It thus appears that in the atoms of uranium there are concentrated in about one-half the volume thirty-two more electrons than in the atoms of neodymium, the total numbers of electrons being, respectively, ninety-two and sixty.

It is perhaps significant in view of these facts that elements of higher atomic number than uranium are not known to exist, and that most of those of immediately lower atomic number are unstable. With increasing nuclear charge the attractive forces exerted by the nucleus on the surrounding electrons concentrate the latter nearer and nearer toward the centre of the atom. It does not appear improbable that the exceedingly powerful forces, both of attraction and repulsion, which must result from this concentration may be of sufficient magnitude to assist materially in bringing about those conditions of instability which result in radio-active disintegration. If the large numbers of electrons in the atoms of the radio-active elements be conceived as rotating about the nucleus within the small space which the relatively small atomic volumes allot to the atoms of these elements, with orbits of different periods, there will evidently come times periodically when numbers of electrons in excess of the average will all be exerting attractive forces on the positive nucleus in the same direction. In such circumstances it is conceivable that a positively charged constituent of the nucleus might be drawn out of its normal equilibrium position and, the local attractive forces which held it in its equilibrium position being overbalanced by the repulsive force between this new entity and the positive nucleus acting as a whole, be sent on its path as an  $\alpha$ -particle. The rate of decay of the atoms of the elements would then depend on the frequency with which this favourable configuration of electrons, which is just sufficient to exert the critical attractive force, occurred. The more stable the nucleus, the greater would the numbers of electrons all acting in the same direction need to be. But the greater the concentration required, the less frequently will it occur, other things being equal. Hence, for a more stable nucleus the rate of decay must be less. The rate of decay would thus depend primarily on the stability of the nucleus, and the mechanism suggested would constitute the trigger action by which the actual disintegration was brought about.

ROBERT N. PEASE,

(National Research Fellow in Chemistry).

Laboratory of Physical Chemistry,  
Princeton University, Princeton, N. J.,

August 6.

### The Freshwater Winkle.

I WAS, recently, fortunate enough to obtain a pair of the yellow-bodied variety of the freshwater winkle (*P. contecta*) from what I understand was the first consignment to be imported into this country. Unfortunately the female died, and when I removed it from the aquarium the body fell out of the shell, the snail having apparently been dead a day or two. I then noticed that there was a row of five fully-formed baby snails—about  $\frac{1}{4}$  inch in diameter—in the gelatinous egg-sac.

Although I thought there was little possibility of their being alive, I released them with a pair of scissors and placed them in a saucer of water. For twenty-four hours or so there was no sign of life, but, on the second day, I noticed that an operculum was forming on each and that the tentacled head of two of them had been extruded. These were immediately placed in a well-established aquarium, and the following day the other three were similarly dealt with, they having also become active. All are now feeding upon the confervæ on the sides of the tank and apparently doing well.

I have never heard of such an experiment having met with success, and shall be glad to learn whether the result is new.

A. E. HODGE.

### The Effect of a Lead Salt on Lepidopterous Larvæ.

FOR some time we have been studying the effect of adding various metallic salts to the food of the larvæ of Lepidoptera, and, as the results will not be ready for publication for about a year, desire to direct attention to the surprising result of using a salt of lead. When a dozen larvæ of *S. ocellatus* were fed on sprigs of apple which had been treated with lead nitrate it was soon obvious that they were eating more freely and growing more rapidly than the controls; by the time they were about three-fourths grown they consumed double the daily ration eaten by the latter. There was considerable disease among the controls and in another experimental batch, but those getting lead remained perfectly healthy and pupated about a fortnight earlier than the controls. The pupæ were a very fine lot, the males weighing on the average about 15 per cent. more than the controls, and the moths were large and somewhat peculiarly coloured; there were too few females for a comparison to be made. Confirmatory results have been obtained with the larvæ of other moths.

This curious result is not without parallel. The herbage near the chimneys of lead-smelting works contains appreciable amounts of lead, and cases of lead poisoning have occurred among sheep; in Weardale, however, it is a common practice to pasture sheep as near as possible to these chimneys when they are being fattened, as the farmers consider that they fatten much more quickly than on other parts of the moors.

F. C. GARRETT,  
HILDA GARRETT.

### The Pigeon Tick.

THERE is a slight error in the statement of L. H. Matthews and A. D. Hobson in NATURE of September 2, p. 313, with regard to the latest previous record of the pigeon tick *Argas reflexus*. In 1917 I secured four specimens from the tower of Canterbury Cathedral. At least two living specimens were forwarded to Mr. C. Warburton at the time.

The Cathedral receives a special cleaning every four years and *Argas reflexus* is invariably dislodged on these occasions.

A. G. LOWNDES.

Marlborough College, September 4.

The Theory of Numbers.<sup>1</sup>

By Prof. G. H. HARDY, M.A., F.R.S.

I FIND myself to-day in the same embarrassing position in which a predecessor of mine at Oxford found himself at Bradford in 1875, the president of a Section, probably the largest and most heterogeneous in the Association, which is absorbed by a multitude of divergent professional interests, none of which agree with his or mine.

There are two courses possible in such circumstances. One is to take refuge, as Prof. Henry Smith did then, with visible reluctance, in a series of general propositions to which mathematicians, physicists, and astronomers may all be expected to return a polite assent. The importance of science and scientific method, the need for better organisation of scientific education and research, are all topics on which I could no doubt say something without undue strain either on my own honesty or on your credulity. That there is no finer education and discipline than natural science; that it is, as Dr. Campbell has said, "the noblest of the arts"; that the crowning achievements of science lie in those directions with which this Section is professionally concerned: all this I could say with complete sincerity, and, if I were the head of a deputation approaching a Government Department, I suppose that I would not shirk even so unprofitable a task.

It is unfortunate that these essential and edifying truths, important as it is that they should be repeated as loudly as possible from time to time, are, to the man whose interest in life lies in scientific work and not in propaganda, unexciting, and in fact quite intolerably dull. I could, if I chose, say all these things, but, even if I wanted to, I should scarcely increase your respect for mathematics and mathematicians by repeating to you what you have said yourselves, or read in the newspapers, a hundred times already. I shall say them all some day; the time will come when we shall none of us have anything more interesting to say. We need not anticipate our inevitable end.

I propose therefore to adopt the alternative course suggested by my predecessor, and try to say something to you about the one subject about which I have anything to say. It happens, by a fortunate accident, that the particular subject which I love the most, and which presents most of the problems which occupy my own researches, is by no means overwhelmingly recondite or obscure, and indeed is sharply distinguished from almost every other branch of pure mathematics, in that it makes a direct, popular, and almost irresistible appeal to the heart of the ordinary man.

There is, however, one preliminary remark which I cannot resist the temptation of making. The present is a particularly happy moment for a pure mathematician, since it has been marked by one of the greatest recorded triumphs of pure mathematics. This triumph is the work, as it happens, of a man who probably would not describe himself as a mathematician, but who has done more than any mathematician to vindicate the dignity of mathematics, and to put that obscure and perplexing construction,

commonly described as "physical reality," in its proper place.

There is probably less difference between the methods of a physicist and a mathematician than is generally supposed. The most striking among them seems to me to be this, that the mathematician is in much more direct contact with reality. This may perhaps seem to you a paradox, since it is the physicist who deals with the subject-matter to which the epithet "real" is commonly applied. But a very little reflection will show that the "reality" of the physicist, whatever it may be (and it is extraordinarily difficult to say), has few or none of the attributes which common-sense instinctively marks as real. A chair may be a collection of whirling atoms, or an idea in the mind of God. It is not my business to suggest that one account of it is obviously more plausible than the other. Whatever the merits of either of them may be, neither draws its inspiration from the suggestions of common-sense.

Neither the philosophers, nor the physicists themselves, have ever put forward any very convincing account of what physical reality is, or of how the physicist passes, from the confused mass of fact or sensation with which he starts, to the construction of the objects which he classifies as real. We cannot be said, therefore, to know what the subject-matter of physics is; but this need not prevent us from understanding the task which a physicist is trying to perform. That, clearly, is to correlate the incoherent body of facts confronting him with some definite and orderly scheme of abstract relations, the kind of scheme, in short, which he can borrow only from mathematics.

A mathematician, on the other hand, fortunately for him, is not concerned with this physical reality at all. It is impossible to prove, by mathematical reasoning, any proposition whatsoever concerning the physical world, and only a mathematical crank would be likely now to imagine it his function to do so. There is plainly one way only of ascertaining the facts of experience, and that is by observation. It is not the business of a mathematician to suggest one view of the universe or another, but merely to supply the physicists with a collection of abstract schemes, which it is for them to select from, and to adopt or discard at their pleasure.

The most obvious example is to be found in the science of geometry. Mathematicians have constructed a very large number of different systems of geometry, Euclidean or non-Euclidean, of one, two, three, or any number of dimensions. All these systems are of complete and equal validity. They embody the results of mathematicians' observations of *their* reality, a reality far more intense and far more rigid than the dubious and elusive reality of physics. The old-fashioned geometry of Euclid, the entertaining seven-point geometry of Veblen, the space-times of Minkowski and Einstein, are all absolutely and equally real. When a mathematician has constructed, or, to be more accurate, when he has observed them, his professional interest in the matter ends. It may be the seven-point

<sup>1</sup> Presidential address delivered to Section A (Mathematics and Physics) of the British Association at Hull on Sept. 8.

geometry that fits the facts the best, for anything that mathematicians have to say. There may be three dimensions in this room and five next door. As a professional mathematician, I have no idea; I can only ask some competent physicist to instruct me in the facts.

The function of a mathematician, then, is simply to observe the facts about his own intricate system of reality, that astonishingly beautiful complex of logical relations which forms the subject-matter of his science, as if he were an explorer looking at a distant range of mountains, and to record the results of his observations in a series of maps, each of which is a branch of pure mathematics. Many of these maps have been completed, while in others, and these, naturally, are the most interesting, there are vast uncharted regions. Some, it seems, have some relevance to the structure of the physical world, while others have no such tangible application. Among them there is perhaps none quite so fascinating, with quite the same astonishing contrasts of sharp outline and mysterious shade, as that which constitutes the theory of numbers.

The number system of arithmetic is, as we know too well, not without its applications to the sensible world. The currency systems of Europe, for example, conform to it approximately; west of the Vistula, two and two make something approaching four. The practical applications of arithmetic, however, are tedious beyond words. One must probe a little deeper into the subject if one wishes to interest the ordinary man, whose taste in such matters is astonishingly correct, and who turns with joy from the routine of common life to anything strange and odd, like the fourth dimension, or imaginary time, or the theory of the representation of integers by sums of squares or cubes.

It is impossible for me to give you, in the time at my command, any general account of the problems of the theory of numbers, or of the progress that has been made towards their solution even during the last twenty years. I must adopt a much simpler method. I will merely state to you, with a few words of comment, three or four isolated questions, selected in a haphazard way. They are seemingly simple questions, and it is not necessary to be anything of a mathematician to understand them; and I have chosen them for no better reason than that I happen to be interested in them myself. There is no one of them to which I know the answer, nor, so far as I know, does any mathematician in the world; and there is no one of them, with one exception which I have included deliberately, the answer to which any one of us would not make almost any sacrifice to know.

1. *When is a number the sum of two cubes, and what is the number of its representations?* This is my first question, and first of all I will elucidate it by some examples. The numbers  $2=1^3+1^3$  and  $9=2^3+1^3$  are sums of two cubes, while 3 and 4 are not: it is exceptional for a number to be of this particular form. The number of cubes up to 1,000,000 is 100, and the number of numbers, up to this limit and of the form required, cannot exceed 10,000, one-hundredth of the whole. The density of the distribution of such numbers tends to zero as the numbers tend to infinity. Is there, I am asking, any simple criterion by which such numbers can be distinguished?

Again, 2 and 9 are sums of two cubes, and can be expressed in this form in one way only. There are numbers so expressible in a variety of different ways. The least such number is 1729, which is  $12^3+1^3$  and also  $10^3+9^3$ . It is more difficult to find a number with *three* representations; the least such number is

$$175,959,000 = 560^3 + 70^3 = 552^3 + 198^3 = 525^3 + 315^3.$$

One number at any rate is known with *four* representations, namely,

$$19 \times 363510^3$$

(a number of 18 digits), but I am not prepared to assert that it is the least. No number has been calculated, so far as I know, with more than four, but theory, running ahead of computation, shows that numbers exist with five representations, or six, or any number.

A distinguished physicist has argued that the possible number of isotopes of an element is probably limited because, among the ninety or so elements at present under observation, there is none which has more isotopes than six. I dare not criticise a physicist in his own field; but the figures I have quoted may suggest to you that an arithmetical generalisation, based on a corresponding volume of evidence, would be more than a little rash.

There are similar questions, of course, for squares, but the answers to these were found long ago by Euler and by Gauss, and belong to the classical mathematics. Suppose, for simplicity of statement, that the number in question is *prime*. Then, if it is of the form  $4m+1$ , it is a sum of squares, and in one way only, while if it is of the form  $4m+3$  it is not so expressible; and this simple rule may readily be generalised so as to apply to numbers of any form. But there is no similar solution for our actual problem, nor, I need scarcely say, for the analogous problems for fourth, fifth, or higher powers. The smallest number known to be expressible in two ways by two biquadrates is

$$635318657 = 158^4 + 59^4 = 134^4 + 133^4;$$

and I do not believe that any number is known expressible in three. Nor, to my knowledge, has the bare existence of such a number yet been proved. When we come to fifth powers, nothing is known at all. The field for future research is unlimited and practically untrodden.

2. I pass to another question, again about cubes, but of a somewhat different kind. *Is every large number (every number, that is to say, from a definite point onwards) the sum of five cubes?* This is another exceptionally difficult problem. It is known that every number, without exception, is the sum of nine cubes; two numbers, 23 (which is  $2 \cdot 2^3 + 7 \cdot 1^3$ ) and 239, actually require so many. It seems that there are just fifteen numbers, the largest being 454, which need eight, and 121 numbers, the largest being 8042, which need seven; and the evidence suggests forcibly that the six-cube numbers also ultimately disappear. In a lecture which I delivered on this subject at Oxford I stated, on the authority of Dr. Ruckle, that there were two numbers, in the immediate neighbourhood of 1,000,000, which could not be resolved into fewer cubes than six; but Dr. A. E. Western has refuted this assertion by resolving each of them into five, and is of opinion,

I believe, that the six-cube numbers have disappeared entirely considerably before this point. It is conceivable that the five-cube numbers also disappear, but this, if it be so, is probably in depths where computation is helpless. The four-cube numbers must certainly persist for ever, for it is impossible that a number  $9n+4$  or  $9n+5$  should be the sum of three.

I need scarcely add that there is a similar problem for every higher power. For fourth powers the critical number is 16. There is no case, except the simple case of squares, in which the solution is in any sense complete. About the squares there is no mystery; every number is the sum of four squares, and there are infinitely many numbers which cannot be expressed by fewer.

3. I will next raise the question *whether the number*  $2^{137}-1$  *is prime*. I said that I would include one question which does not interest me particularly; and I should like to explain to you the kind of reasons which damp down my interest in this one. I do not know the answer, and I do not care greatly what it is.

The problem belongs to the theory of the so-called "perfect" numbers, which has exercised mathematicians since the times of the Greeks. A number is perfect if, like 6 or 28, it is the sum of all its divisors, unity included. Euclid proved that the number

$$2^m(2^{m+1}-1)$$

is perfect if the second factor is prime; and Euler, 2000 years later, that all *even* perfect numbers are of Euclid's form. It is still unknown whether a perfect number can be odd.

It would obviously be most interesting to know generally in what circumstances a number  $2^n-1$  is prime. It is plain that this can be so only if  $n$  itself is prime, as otherwise the number has obvious factors; and the 137 of my question happens to be the least value of  $n$  for which the answer is still in doubt. You may perhaps be surprised that a question apparently so fascinating should fail to arouse me more.

It was asserted by Mersenne in 1644 that the only values of  $n$ , up to 257, for which  $2^n-1$  is prime are

$$2, 3, 5, 7, 13, 17, 19, 31, 67, 127, 257;$$

and an enormous amount of labour has been expended on attempts to verify this assertion. There are no simple general tests by which the primality of a number chosen at random can be determined, and the amount of computation required in any particular case may be appalling. It has, however, been imagined that Mersenne perhaps knew something which later mathematicians have failed to rediscover. The idea is a little fantastic, but there is no doubt that, so long as the possibility remained, arithmeticians were justified in their determination to ascertain the facts at all costs. "The riddle as to how Mersenne's numbers were discovered remains unsolved," wrote Mr. Rouse Ball in 1891. Mersenne, he observes, was a good mathematician, but not an Euler or a Gauss, and he inclines to attribute the discovery to the exceptional genius of Fermat, the only mathematician of the age whom any one could suspect of being hundreds of years ahead of his time.

These speculations appear extremely fanciful now, for the bubble has at last been pricked. It seems now that Mersenne's assertion, so far from hiding unplumbed depths of mathematical profundity, was a

conjecture based on inadequate empirical evidence, and a somewhat unhappy one at that. It is now known that there are at least four numbers about which Mersenne is definitely wrong; he should have included at any rate 61, 89, and 107, and he should have left out 67. The mistake as regards 61 and 67 was discovered so long ago as 1886, but could be explained with some plausibility, so long as it stood alone, as a merely clerical error. But when Mr. R. E. Powers, in 1911 and 1914, proved that Mersenne was also wrong about 89 and 107, this line of defence collapsed, and it ceased to be possible to take Mersenne's assertion seriously.

The facts may be summed up as follows. Mersenne makes fifty-five assertions, for the fifty-five primes from 2 to 257. Of these assertions forty are true, four false, and eleven still doubtful. Not a bad result, you may think; but there is more to be said. Of the forty correct assertions many, half at least, are trivial, either because the numbers in question are comparatively small, or because they possess quite small and easily detected divisors. The test cases are those in which the numbers are prime, or Mersenne asserts that they are so; there are only four of these cases which are difficult and in which the truth is known; and in these Mersenne is wrong in every case but one.

It seems to me, then, that we must regard Mersenne's assertion as exploded; and for my part it interests me no longer. If he is wrong about 89 and 107, I do not care greatly whether he is wrong about 137 as well, and I should regard the computations necessary to decide as very largely wasted. There are so many much more profitable calculations which a computer could undertake.

I hope that you will not infer that I regard the problem of perfect numbers as uninteresting in itself; that would be very far from the truth. There are at least two intensely interesting problems. The first is the old problem, which so many mathematicians have failed to solve, whether a perfect number can be odd. The second is whether the number of perfect numbers is infinite or not. If we assume that all perfect numbers are even, we can state this problem in a still more arresting form. *Are there infinitely many primes of the form*  $2^n-1$ ? I find it difficult to imagine a problem more fascinating or more intricate than that. It is plain, though, that this is a question which computation can never decide, and it is very unlikely that it can ever give us any data of serious value. And the problem itself really belongs to a different chapter of the theory, to which I should like next to direct your attention.

4. *Are there infinitely many primes of the form*  $n^2+1$ ? Let me first remind you of some well-known facts in regard to the distribution of primes.

There are infinitely many primes; their density decreases as the numbers increase, and tends to zero when the numbers tend to infinity. More accurately, the number of primes less than  $x$  is, to a first approximation,

$$\frac{x}{\log x}$$

The chance that a large number  $n$ , selected at random, should be prime is, we may say, about  $\frac{1}{\log n}$ .

Still more precisely, the "logarithm-integral"

$$\text{Li } x = \int_2^x \frac{dt}{\log t}$$

gives a very good approximation to the number of primes. This number differs from  $\text{Li } x$  by a function of  $x$  which oscillates continually, as Mr. Littlewood, in defiance of all empirical evidence to the contrary, has shown, between positive and negative values, and is sometimes large, of the order of magnitude  $\sqrt{x}$  or thereabouts, but always small in comparison with the logarithm-integral itself.

Except for one lacuna, which I must pass over in silence now, this problem of the general distribution of primes, the first and central problem of the theory, is in all essentials solved. But a variety of most interesting problems remain as to the distribution of primes among numbers of special forms. The first and simplest of these is that of the arithmetical progressions: *How are the primes distributed among all possible arithmetical progressions  $an+b$ ?* We may leave out of account the case in which  $a$  and  $b$  have a common factor; this case is trivial, since  $an+b$  is then obviously not prime.

The first step towards a solution was made by Dirichlet, who proved for the first time, in 1837, that any such arithmetical progression contains an infinity of primes. It has since been shown that the primes are, to a first approximation at any rate, distributed evenly among all the arithmetical progressions. When we pursue the analysis further, differences appear; there are on the average, for example, more primes  $4n+3$  than primes  $4n+1$ , though it is not true, as the evidence of statistics has led some mathematicians to conclude too hastily, that there is always an excess to whatever point the enumeration is carried.

The problem of the arithmetical progressions, then, may also be regarded as solved; and the same is true of the problem of the primes of a given quadratic form, say  $am^2+2bmn+cn^2$ , homogeneous in the two variables  $m$  and  $n$ . To take, for example, the simplest and most striking case, there is the natural and obvious number of primes  $m^2+n^2$ . A prime is of this form, as I have mentioned already, if, and only if, it is of the form  $4k+1$ . The quadratic problem reduces here to a particular case of the problem of the arithmetical progressions.

When we pass to cubic forms, or forms of higher degree, we come to the region of the unknown. This, however, is not the field of inquiry which I wish now to commend to your attention. The quadratic forms of which I have spoken are forms in two independent variables  $m$  and  $n$ ; the form  $n^2+1$  of my question is a non-homogeneous form in a single variable  $n$ , the simplest case of the general form  $an^2+bn+c$ . It is clear that one may ask the same question for forms of any degree: are there, for example, infinitely many primes  $n^3+2$  or  $n^4+1$ ? I do not choose  $n^3+1$ , naturally, because of the obvious factor  $n+1$ .

This problem is one in which computation can still play an important part. You will remember that I stated the same problem for perfect numbers. There a computer is helpless. For the numbers  $2^n-1$ , which dominate the theory, increase with unmanageable

rapidity, and the data collected by the computers appear, so far as one can judge, to be almost devoid of value. Here the data are ample, and; though the question is still unanswered, there is really strong statistical evidence for supposing a particular answer to be true. It seems that the answer is affirmative, and that there is a definite approximate formula for the number of primes in question. This formula is

$$\frac{1}{2} \text{Li } \sqrt{x} \times \left(1 + \frac{1}{3}\right) \left(1 - \frac{1}{5}\right) \left(1 + \frac{1}{7}\right) \left(1 + \frac{1}{11}\right) \dots,$$

where the product extends over all primes  $p$ , and the positive sign is chosen when  $p$  is of the form  $4n+3$ . Dr. A. E. Western has submitted this formula to a most exhaustive numerical check. It so happens that Colonel Cunningham some years ago computed a table of primes  $n^2+1$  up to the value 15,000 of  $n$ , a limit altogether beyond the range of the standard factor tables, and Cunningham's table has made practicable an unusually comprehensive test. The actual number of primes is 1199, while the number predicted is 1219. The error, less than 1 in 50, is much less than one could reasonably expect. The formula stands its test triumphantly, but I should be deluding you if I pretended to see any immediate prospect of an accurate proof.

5. The last problem I shall state to you is this: *Are there infinitely many prime-pairs  $p, p+2$ ?* One may put the problem more generally: *Does any group of primes, with assigned and possible differences, recur indefinitely, and what is the law of its recurrence?*

I must first explain what I mean by a "possible" group of primes. It is possible that  $p$  and  $p+2$  should both be prime, like 3, 5, or 101, 103. It is not possible (unless  $p$  is 3) that  $p, p+2$  and  $p+4$  should all be prime, for one of them must be a multiple of 3: but  $p, p+2, p+6$  or  $p, p+4, p+6$  are possible triplets of primes. Similarly

$$p, p+2, p+6, p+8, p+12$$

can all be prime, so far as any elementary test of divisibility shows, and in fact 5, 7, 11, 13 and 17 satisfy the conditions. It is easy to define precisely what we understand by a "possible" group. We mean a group the differences in which, like 0, 2, 6, have at least one missing residue to every possible modulus. The "impossible" group 0, 2, 4 does not satisfy the condition, for the remainders after division by 3 are 0, 2, 1, a complete set of residues to modulus 3. There is no difficulty in specifying possible groups of any length we please.

We define in this manner, then, a "possible" group of primes, and we put the questions: Do all possible groups of primes actually occur, do they recur indefinitely often, and how often on the average do they recur? Here again it would seem that the answers are affirmative, that all possible groups occur, and continue to occur for ever, and with a frequency the law of which can be assigned. The order of magnitude of the number of prime-pairs,  $p, p+2$ , or  $p, p+4$ , or  $p, p+6$ , both members of which are less than a large number  $x$ , is, it appears,

$$\frac{x}{(\log x)^2}$$

The order of magnitude of the corresponding number of triplets, of any possible type, is

$$\frac{x}{(\log x)^3}$$

and so on generally. Further, we can assign the relative frequencies of pairs or triplets of different types; there are, for example, about twice as many pairs the difference of which is 6 as there are pairs with the difference 2. All these results have been tested by actual enumeration from the factor tables of the first million numbers; and a physicist would probably regard them as proved, though we of course know very well that they are not.

There is a great deal of mathematics the purport of which is quite impossible for any amateur to grasp, and which, however beautiful and important it may be, must always remain the possession of a narrow circle

of experts. It is the peculiarity of the theory of numbers that much of it could be published broadcast, and would win new readers for the *Daily Mail*. The positive integers do not lie, like the logical foundations of mathematics, in the scarcely visible distance, nor in the uncomfortably tangled foreground, like the immediate data of the physical world, but at a decent middle distance, where the outlines are clear and yet some element of mystery remains. There is no one so blind that he does not see them, and no one so sharp-sighted that his vision does not fail; they stand there a continual and inevitable challenge to the curiosity of every healthy mind. I have merely directed your attention for a moment to a few of the less immediately conspicuous features of the landscape, in the hope that I may sharpen your curiosity a little, and that some may feel tempted to walk a little nearer and take a closer view.

### The Organisation of Research.<sup>1</sup>

By Principal J. C. IRVINE, C.B.E., D.Sc., LL.D., F.R.S.

THE British Association was the product of an age rather than the inspiration of any one man, yet of those who first gave practical effect to the movement which has spread scientific learning and has bound its devotees in a goodly fellowship there was no more eager spirit than Sir David Brewster. It is not an exaggerated claim that it was he who founded the British Association. One may trace his enlightened action to a desire to combat the apathy and distrust shown by the Government of his day towards scientific work and even scientific workers. Only in the historical sense can I claim any relationship with Brewster. It is my privilege to occupy the Principalship he once held, and I cannot escape from the thought that the daily tasks now mine were once his.

It is thus inevitable that to-day a name often in my mind should spring once more into recollection, especially as my distinguished predecessor was present at the first Hull meeting in 1853, when he contributed two papers to Section A. Chemists should be among the first to pay grateful tribute to Brewster's efforts on behalf of science, and I propose, therefore, to include in my address a review of the position scientific chemistry has won since his day in public and official estimation. Moreover, at the express suggestion of some of our members whose opinions cannot be disregarded, I am induced to add the consideration of the new responsibilities chemists have incurred now that so many of Brewster's hopes have been realised. These were recently submitted by me to another audience and, through the medium of an article in *NATURE* (July 22, p. 131), are possibly known to you already, but I agree with my advisers that their importance warrants further elaboration and wider discussion.

It would be idle to recall the lowly position of chemistry as an educative force in this country, or to reconstruct the difficulties with which the scientific chemist was confronted during the first thirty years of the nineteenth century. Present difficulties are

serious enough, and press for all our attention, without dwelling unduly on troubles of the past. But we must at least remember that in the early days of the British Association "schools" of chemistry were in their infancy, and that systematic instruction in the science was difficult to obtain. Another point of fundamental importance which has to be borne in mind is that the masters of the subject were then for the most part solitary workers.

It is difficult for us, looking back through the years, to realise what it must have meant to search for truth under conditions which were discouraging, if not actually hostile. Yet, although his labours were often thankless and unrewarded, the chemist of the time was probably a riper philosopher and a finer enthusiast than his successor of to-day. He pursued his inquiries amid fewer distractions, and in many ways his lot must have been happy, save when tormented by the thought that a subject so potent as chemistry in developing the intellectual and material welfare of the community should remain neglected to an extent which to us seems incredible.

Public sympathy was lacking, Government support was negligible or grudgingly bestowed, and there was little or no co-operation between scientific chemistry and industry. As an unaided enthusiast the chemist was left to pursue his way without the stimulus, now happily ours, which comes from the feeling that work is supported by educated and enlightened appreciation.

Let me quote from one of Faraday's letters now in my possession and, so far as I can trace, unpublished. Writing to a friend immediately before the foundation of the British Association, he relates that a manufacturer had adopted a process developed in the course of an investigation carried out in the Royal Institution. The letter continues: "He" (the manufacturer) "writes me word that, having repeated our experiments, he finds the product very good, and as our information was given openly to the world he, as a matter of compliment, has presented me with some pairs of razors to give away."<sup>2</sup> If ever there was a claimant

<sup>1</sup> From Part I. of the presidential address delivered to Section B (Chemistry) of the British Association at Hull on Sept. 7.

which could be described as empty, surely this was one; yet the letter gives the impression that Faraday himself was quite content with his reward.

It is perhaps unfair to quote Faraday as a type, for few men are blessed with his transparent simplicity of character, but there is obviously a great gulf fixed between the present day and a time when a debt of honour could be cancelled in such a manner. A little reflection will show that the British Association has played a useful part in discrediting the idea that because so much scientific discovery is given "openly to the world," those who profit by such discoveries should be absolved from their reasonable obligations. Even where scientific workers do not expect or desire personal reward, the institutions which provide them with their facilities are often sorely in need. The recognition, not yet complete, but more adequate than once was the case, that the labourer is worthy of his hire, represents only one minor change which the years have brought.

An even greater contrast, embodying more important principles, is found in the changed attitude of the State towards scientific education and discovery. Remember Brewster's fond hope that, by means of our Association, the whole status of science would be raised, and that a greater measure of support and encouragement would be received from the Government. How eagerly the venerable physicist must have listened to the Presidential Address delivered at the twenty-third meeting of the Association assembled in Hull for the first time. It dealt with many problems familiar to him. No doubt he followed with keen interest the account of the observations on nebulae made with Lord Rosse's telescope, and appreciated the references to the work of Joule and Thomson. The address was a masterly synopsis of scientific progress, but from time to time a new note steals in. There is a significant reference to a consultation with the Chancellor of the Exchequer, another to a conversation with Mr. Gladstone, and a third to a working arrangement concluded with the Admiralty. These would fall sweetly on Brewster's ear, and he would cordially approve of the report of our Parliamentary Committee, which had established sympathetic contact with the House of Commons. He could not fail to be impressed with the changes a few years had brought.

Let us bridge the further gap of sixty-nine years which separates us from that day. The contrast is amazing, and once more we can trace the steady, persistent influence of the British Association in bringing about what is practically a revolution in public and official opinion. We have learned many lessons. The change has come suddenly, but it was not spontaneous. Many years had to be spent in disseminating the idea that research is a vital necessity, and toward this end presidents of our Association have not hesitated, year after year, to add the weight of their influence and eloquence. It was courageous of them to do so. I would refer you particularly to the forcible appeals made by Sir James Dewar at Belfast and Sir Norman Lockyer at Southport, when the plea for more research was laid before the Association, and thus found its way by the most direct channel to the press and to the public. No doubt many other factors have played a part in creating a research atmosphere in this country, but the steady pressure exerted by the

British Association is not the least important of these influences.

The principles of science are to-day widely spread; systematic scientific training has found an honourable place in the schools and in the colleges; above all, there is the realisation that much of human progress is based on scientific inquiry, and at last this is fostered and, in part, financed as a definite unit of national educational policy. Public funds are devoted to provide facilities for those who are competent to pursue scientific investigations, and in this way the State, acting through the Department of Scientific and Industrial Research, has assumed the double responsibility of providing for the advancement of knowledge and for the application of scientific methods to industry. Scientific workers have been given the opportunities they desired, and it remains for us to justify all that has been done. We have to-day glanced briefly at the painful toil and long years of preparation; now it falls to us to sow the first crop and reap the first harvest.

Thanks to the wisdom and foresight of others, it has been possible to frame the Government policy in the light of the experience gained with pre-existing research organisations. The pioneer scheme of the kind is that administered by the Commissioners of the 1851 Exhibition, who since 1890 have awarded research scholarships to selected graduates. When in 1901 Mr. Carnegie's benefaction was applied to the Scottish Universities the trustees wisely determined to devote part of the revenues to the provision of research awards which take the form of scholarships, fellowships, and research lectureships. These have proved an immense boon to Scottish graduates, and the success of the venture is sufficiently testified by the fact that the Government research scheme was largely modelled on that of the Carnegie Trust.

In each of these organisations chemistry bulks largely, and the future of our subject is intimately connected with their success or failure. The issue lies largely in our hands. We must not forget that we are only at the beginning of a great movement, and that fresh duties now devolve upon us. It was my privilege for some years to direct the work of a chemistry institute, where research was organised on lines which the operation of the Government scheme will make general. If, from the very nature of things, my experience cannot be lengthy it is at least intimate, and I may perhaps be allowed to lay before you my impressions of the problems we have to face.

Two main objectives lie before us: the expansion of useful learning and the diffusion of research experience among a selected class. This class in itself will form a new unit in the scientific community, and from it will emerge the "exceptional man" to whom, quoting Sir James Dewar, "we owe our reputation and no small part of our prosperity." When these words were uttered in 1902 it was a true saying that "for such men we have to wait upon the will of Heaven." It is still true, but there is no longer the same risk that the exceptional man will fall by the way through lack of means. Many types of the exceptional man will be forthcoming, and you must not imagine that I am regarding him merely as one who will occupy a university chair. He will be found more frequently in industry, where his function will



be to hand on the ideas inspired by his genius to the ordinary investigator.

I have no intention of wearying you by elaborating my views on the training required to produce these different types. My task is greatly simplified if you will agree that the first step must be systematic experience in pure and disinterested research, without any reference to the more complicated problems of applied science. This is necessary, for if our technical research is to progress on sound lines the foundations must be truly laid. I have no doubt as to the prosperity of scientific industries in this country so long as we avoid hasty and premature specialisation in those who control them. We may take it that in the future the great majority of expert chemists will pass through a stage in which they make their first acquaintance with the methods of research under supervision and guidance. The movement is already in progress. The Government grants are awarded generously and widely. The conditions attached are moderate and reasonable, and there is a rush to chemical research in our colleges. Here, then, I issue my first note of warning, and it is to the professors. It is an easy matter to nominate a research student; a research laboratory comfortably filled with workers is an inspiring sight, but there are few more harassing duties than those which involve the direction of young research chemists. No matter how great their enthusiasm and abilities, these pupils have to be trained, guided, inspired, and this help can come only from the man of mature years and experience. I am well aware that scorn has been poured on the idea that research requires training. No doubt the word is an expression of intellectual freedom, but I have seen too many good investigators spoiled and discouraged through lack of this help to hold any other opinion than that training is necessary. I remember, too, years when I wandered more or less aimlessly down the by-paths of pointless inquiries, and I then learned to realise the necessity of economising the time and effort of others.

The duties of such a supervisor cannot be light. He must possess versatility; for although a "research school" will doubtless preserve one particular type of problem as its main feature, there must be a sufficient variety of topics if narrow specialisation is to be avoided. Remember, also, that there can be no formal course of instruction suitable for groups of students, no common course applicable to all pupils and all inquiries. Individual attention is the first necessity, and the educative value of early researches is largely derived from the daily consultations at the laboratory bench or in the library. The responsibility of becoming a research supervisor is great, and, even with the best of good will, many find it difficult to enter sympathetically into the mental position of the beginner. An unexpected result is obtained, an analysis fails to agree, and the supervisor, out of his long experience, can explain the anomaly at once, and generally does so. If the pupil is to derive any real benefit from his difficulties, his adviser must for the moment place himself in the position of one equally puzzled, and must lead his collaborator to sum up the evidence and arrive at the correct conclusion for himself. The policy thus outlined is, I believe, sound, but it makes severe demands on patience, sympathy, and, above all, time.

Research supervision, if conscientiously given, involves the complete absorption of the director's energy and leisure. There is a rich reward in seeing pupils develop as independent thinkers and workers, but the supervisor has to pay the price of seeing his own research output fade away. He will have more conjoint papers, but fewer individual publications, and limitations will be placed on the nature of his work by the restricted technique of his pupils.

I have defined a high standard, almost an ideal, but there is, of course, the easy alternative to use the technical skill of the graduate to carry out the more laborious and mechanical parts of one's own researches, to regard these young workers as so many extra pairs of hands. I need not elaborate the outcome of such a policy.

There is another temptation, and that, in an institution of university rank, is for the professor to leave research training in the hands of his lecturers, selecting as his collaborators only those workers who have passed the apprenticeship stage. This, I am convinced, is a mistake. Nothing consolidates a research school more firmly than the feeling that all who labour in its interests are recognised by having assigned to them collaborators of real ability.

I am not yet done with the professor and his staff, for they will have other matters to attend to if research schools are to justify their existence and to do more than add to the bulk of our journals. In many cases it will be found that the most gifted of the young workers under their care lack what, for want of a better expression, is known as "general culture." Remember, these graduates have just emerged from a period of intensive study in which chemistry and the allied sciences have absorbed most of their attention. For their own sake and in the interests of our subject, they must be protected from the criticism that a scientific education is limited in outlook and leads to a narrow specialism. The research years are plastic years, and many opportunities may be found in the course of the daily consultations "to impress upon the student that there is literature other than the records of scientific papers, and music beyond the range of student songs." I mention only two of the many things which may be added to elevate and refine the research student's life. Others will at once occur to you, but I turn to an entirely different feature of research training, for which I make a special plea: I refer to the inculcation of business-like methods. You will not accuse me, I hope, of departing from the spirit of scholarship or of descending into petty detail, but my experience has been that research students require firm handling. Emancipated as they are from the restrictions of undergraduate study, the idea seems to prevail that these workers ought to be excused the rules which usually govern a teaching laboratory, and may therefore work in any manner they choose. It requires, in fact, the force of a personal example to demonstrate to them that research work can be carried out with all the neatness and care demanded by quantitative analysis. Again, in the exercise of their new freedom young collaborators are inclined to neglect recording their results in a manner which secures a permanent record and is of use to the senior collaborator. As a rule, the compilation of results for publication is not

done by the experimenter, and a somewhat elaborate system of records has to be devised. It should be possible, twenty years after the work has been done, to quote the reasons which led to the initiation of each experiment, and to trace the source and history of each specimen analysed, or upon which standard physical constants have been determined. I need not enter into detail in this connexion beyond stating that, although a system which secures these objects has for many years been adopted in St. Andrews, constant effort is required to maintain the standard.

One of the greatest anxieties of the research supervisor is, however, the avoidance of extravagance and waste. The student is sometimes inclined to assume a lordly attitude and to regard such matters as the systematic recovery of solvents beneath his notice. My view is that, as a matter of discipline as much as in the interests of economy, extravagant working should not be tolerated. There is naturally an economic limit where the time spent in such economics exceeds in value the materials saved, and a correct balance must be adjusted. It is often instructive to lay before a research worker an estimate of the cost of an investigation in which these factors of time and material are taken into account. As a general rule it will be found that the saving of material is of greater moment than the loss of time. The point may not be vitally important in the academic laboratory, but in the factory, to which most of these workers eventually migrate, they will soon have the lesson thrust upon them that their time and salary bear a small proportion to costs of production.

You will see I have changed my warning from the professor to the student. A student generation is short. In a few years, when almost as a matter of course the best of young chemists will qualify for the Doctor of Philosophy degree, it will be forgotten that these facilities have come to us, not as a right, but as a privilege. Those who reap the advantages of these privileges must prove that the efforts made on their behalf have been worth while.

Looking at the position broadly, if one may criticise the research schemes of to-day, it is in the sense that the main bulk of support is afforded to the research apprentice, and the situation has become infinitely harder for the supervisor in that new and onerous tasks are imposed upon him. To expect him to undertake his normal duties and, as a voluntary act, the additional burden of research training is to force him into the devastation of late hours and overwork. The question is at once raised—Are we using our mature research material to the best advantage, and is our policy sufficiently focussed on the requirements of the experienced investigator? I think it will generally be agreed that members of the professor or lecturer class who join in the movement must be relieved in great measure of teaching and administrative work. I am decidedly of the opinion that the research supervisor must be a teacher, and must mingle freely with undergraduates, so as to recognise at the earliest possible stage the potential investigators of the future and guide their studies. To meet this necessity universities and colleges must realise that their curriculum has been extended and that staffs must be

enlarged accordingly. There could then be definite periods of freedom from official duties for those who undertake research training as an added task. Opportunities must also be given to these "exceptional men" to travel occasionally to other centres and refresh themselves in the company of kindred workers. It is evident that our universities are called upon to share the financial burden involved in a national research scheme to a much greater extent than possibly they know.

I may perhaps summarise some of the conclusions reached in thinking over these questions. The first and most important is that in each institution there should be a Board or Standing Committee entrusted with the supervision of research. The functions of such a body would be widely varied and would include:—

1. The allocation of money voted specifically from university or college funds for research expenses.
2. The power to recommend additions to the teaching staff in departments actively engaged in research.
3. The recommendation of promotions on the basis of research achievement.
4. The supervision of regulations governing higher degrees.

Among the more specific problems which confront this Board are the following:—

1. The creation of research libraries where reference works can be consulted immediately.
2. The provision of publication grants, so that where no periodical literature is available the work will not remain buried or obscure.
3. The allocation of travelling grants to enable workers to visit libraries, to inspect manufacturing processes, and to attend the meetings of scientific societies.

There is one thing which a Research Board should avoid. It is, I am convinced, a mistake for a governing body to call for an annual list of publications from research laboratories. Nothing could be more injurious to the true atmosphere of research than the feeling of pressure that papers must be published or the Department will be discredited.

What I have said so far may seem largely a recital of new difficulties, but they are not insurmountable, and to overcome them adds a zest to life. It would have taken too long to go more fully into details, and I have tried to avoid making my address a research syllabus, merely giving in general terms the impressions gained during the twenty years in which the St. Andrews Research Laboratories have been in existence.

I have confined myself to the first stage in the research development of the chemist. His future path may lead him either to the factory or to the lecture-room, and in the end the exceptional man will be found in the director's laboratory or in the professor's chair. However difficult these roads may prove, I feel that with the financial aid now available, supported by the self-sacrificing labours of those who devote themselves to furthering this work, he has the opportunity to reach the goal. It is the beginning of a new scientific age, and we may look forward confidently to the time when there will be no lack of trained scientific intellects to lead our policy and direct our efforts in all that concerns the welfare of the country.

## The Total Solar Eclipse of September 21.

By DR. A. C. D. CROMMELIN.

THERE are at present in the Saros Cycle two series of eclipses which have unusual length of totality; one including those of 1865, 1883, 1901, 1919, the other including the great Indian eclipse of 1868, in which the spectroscope was first applied to the prominences; also those of 1886 (West Indies) and 1904 (Pacific). The forthcoming eclipse, September 21, being three Saroses after that of 1868, is in nearly the same longitude, but has moved southward, the only land stations available being the Maldives, Christmas Island, and Australia.

The Maldives have the disadvantages of a rather low sun, some difficulty of access, owing to the reefs surrounding the islands, probability of high wind, together with a poor health record for European visitors; they are, however, being occupied by Mr. Evershed. Christmas Island lies in the longitude of maximum totality (6 minutes), but being near the northern limit of totality it will enjoy only 3½ minutes. This is, however, amply long enough for the programme planned. The station is occupied by Messrs. Jones and Melotte from Greenwich, their equipment consisting of the 13-inch astrographic equatorial, on a mounting specially constructed for the low latitude of the station. When the same instrument was used in Brazil in 1919 the star-images were diffused, owing probably to slight warping of the celostat mirror by the heat of the sun before totality. The unsuitability of the celostat had been foreseen, but the short interval between the armistice and the departure of the expedition made it impossible to provide an equatorial mounting.

On the present occasion it is desired to secure a completely satisfactory check on the 1919 results; these tended to confirm the amount of shift of light by the sun's gravitation predicted by Einstein; the difference in the results given by the two instruments in Brazil was, however, too large to permit the results to be taken as absolutely final, and a further test is desirable. The star-field at this totality is, unfortunately, much less favourable than that in 1919, which was probably the field containing the largest number of bright stars close to the ecliptic. There are, however, a fair number of stars of the eighth magnitude or brighter in the present field, and it is hoped that these may be photographed with somewhat longer exposures than those given before. The corona will probably be of the "Minimum" type, with little extension near the poles; this should enable stars fairly near the sun,

which will have a large factor of shift, to be photographed.

Christmas Island is occupied by a Phosphate Company, under Scottish management, which has given great assistance to the expedition in transporting their baggage, in erecting huts, providing workmen, etc. Reports received in July stated that the adjustment of the instruments was complete, but that the weather during May had been very wet, and little observing was possible; check plates of the eclipse field had, however, been secured. The rainy season was, however, nearly at an end, and it was hoped that more work would shortly be possible; in addition to the eclipse programme it was planned to take a series of photometric plates, to connect the magnitude scales of the northern and southern hemispheres. Profs. Freundlich and Einstein also arranged to observe from Christmas Island, their programme being much the same as that of the British observers.

The station on the coast of West Australia has a high sun, long totality, and excellent weather prospects; but it is difficult of access, it being necessary to anchor some miles out, and land in small boats through surf. Several parties are there; that with the largest equipment is from the Lick Observatory, under Prof. Campbell. This party also makes the Einstein problem the chief item of the programme. To avoid a long stay at the eclipse camp the check plates were taken at Fiji on the voyage out. Other parties at this station are from Canada and from Perth (Australia).

The observatories of Adelaide, Melbourne, and Sydney are sending expeditions to stations in Central Australia and in Queensland. The weather prospects are good at both, but the sun in Queensland is rather low. They are understood to be attempting the Einstein problem, in addition to the older eclipse work of photography of the corona and its spectrum.

There is every reason to hope for success at some of the stations; fine weather at all of them should lead to results of a decisive character on the Einstein problem. The results will not be available for some time, as the plates will not be measured till the return of the different parties. They will, however, be developed, *in situ*, which will permit a good idea of their character to be formed. In this connexion it may be noted that there is no cable to Christmas Island, but it is expected that a Dutch man-of-war will be there, which might send a wireless message to Java.

## The Deflection of Light in a Gravitational Field.

By HERBERT DINGLE.

FROM an experimental point of view, Einstein's general theory of relativity is at present in an ambiguous position. It is well known that there are three conceivable tests between its conclusions and those of the traditional ideas which it attempts to displace. With regard to the first of these—the movement of the perihelion position of Mercury—the success

of the theory is decidedly impressive; all the more so, perhaps, because the result was stumbled upon, as it were, involuntarily. In seeking first the gravitational field of the sun, Einstein found the true orbit of Mercury added unto him. On the other hand, the predicted displacement of the solar spectrum lines certainly conjures up a serious obstacle. The evidence,

it is true, is contradictory, but, such as it is, it seems to show a balance against the existence of the displacement. The extreme difficulty and complexity of the experimental work must, nevertheless, be borne in mind. Perhaps it is scarcely possible, in the present state of our knowledge and experimental equipment, to obtain a definite solution of the problem. The third test—concerning the deflection of light in a gravitational field—accordingly becomes of very considerable importance, and to many minds constitutes the deciding factor in their judgment of the theory.

Consequently, the chief item in the programme of the Royal Astronomical Society's expedition to Christmas Island, on the occasion of the total solar eclipse of September 21, will be the investigation of this particular problem. It will be remembered that the original test, on May 29, 1919, was considered by the observers and a large number of others to give conclusive evidence in favour of the relativity theory: it was this result, in fact, that directed general attention to the theory, and made Einstein, for a brief spell, a noteworthy figure in public esteem. The interpretation of the observations, however, has been subjected to various criticisms. A refracting atmosphere of the sun has been proposed. Attempts have been made to explain the effect as a result of terrestrial atmospheric refraction arising from a temperature gradient across the boundary of the moon's shadow-cone. Still more serious is the evidence of the mutual displacement of adjacent photographic images: the question arises whether the observed positions of the star images might not be, to some extent, dependent on the intensity of the coronal light. It must be admitted that the criticisms have been well met. Nevertheless, so fundamentally important a matter can scarcely be regarded as finally settled by a single set of observations, and the repetition which is about to take place is anything but a superfluous confirmation of previous knowledge.

It will be opportune at this time to recall the nature of the problem, and see wherein lies the difference between the traditional and the relativity conceptions which makes the prospective test possible. From the time of Newton until quite recently, gravitation has been looked upon as an essential property of matter—as characteristic as the property of inertia. Whenever we find matter showing the unmistakable effects of inertia, we find also evidence of gravitational influence. The universality of these twin phenomena has so impressed physicists that they have come to look upon them as the fundamental properties of matter. Matter is, by definition, that which has inertia and exerts gravitational attraction. Nevertheless, it is well to point out that inertia and gravitation are not the properties by which matter is generally recognised. With regard to most of the matter in the universe, there is no evidence that they exist. We announce the presence of matter when we see it: in other words, matter everywhere has the power of emitting or absorbing light—or, more generally, radiation. We see light, and we deduce a star; the light fluctuates, and we deduce absorbing matter. If, according to the true scientific method, we establish our fundamental conceptions on the groundwork of pure observation, we must place the power to radiate and absorb light

at least as deep down in the nature of matter as the inertial-gravitational property. The recognition of either property is universally accepted as evidence of the existence of matter.

The difference with which we are concerned between the traditional and the relativistic conceptions may be expressed in this way: that whereas the older view gives no *a priori* indication of a relation between the two fundamental material influences, gravitation and light, it is an essential condition of the relativity theory that such a relation exists. A large and valuable system of thought has been built up—mainly during the last hundred years—in which radiation and gravitation are completely independent. Radiation submits to analysis and invites correlation with other physical phenomena; gravitation stands inaccessiblely apart. The complex organism of electromagnetism, embracing as it does radiation, the æther, electricity, magnetism, the atom—even inertia (for radiation possesses inertia)—seems capable of assimilating the whole of physics—except gravitation. Matter appears to be the source of two streams of phenomena, one summarised in electromagnetism and the other in gravitation, and between them there is a great gulf fixed. The completeness of the duality lies, of course, only in the conceptions. Experimental evidence of a bridge across the gulf might have arisen at any time. Standing now on the bridge, it seems a little strange that it was not sought before. Inertia, in submitting to the electromagnetic scheme, might carry with it the gravitational property with which, in material bodies, it is always associated, and the electromagnetic inertia of light might be accompanied by a proportionate power to exert and respond to gravitational influence. There is no reason, according to pre-relativity physics, why it should, but neither is there any reason why it should not. The impotence of the electromagnetic theory even to suggest the more probable of the alternatives is its main defect.

There is no such ambiguity in the utterances of the relativity theory. Here gravitation—as a physical existence giving rise to a gravitational field—is ignored: the field alone is considered. The seat of the phenomenon is not sought in the secret nature of matter; it is sought in the space surrounding matter, and is, in fact, regarded as a property of that space—or, rather, space-time. The justification for this view is found in the facts, first, that the evidence for the existence of gravitation is the observed acceleration of one body in the neighbourhood of another; and, second, that the acceleration produced by one body in another is independent of every property of the latter except its position relative to the former. Now a phenomenon manifesting itself as an acceleration (involving the dimensions of space and time only) and producing effects depending only on position, can be submitted to a geometrical treatment, provided that the dimension of time is added to those of space. Instead of speaking of the curved paths of bodies in a homogeneous space-time, we can speak of the straight paths of bodies in a heterogeneous space-time. The same phenomenon is indicated by both statements. Expressed in this way, it seems as though there could be no difference between the two views, except that one might be more convenient than the other. Considered from a physical

point of view, however, the difference between them is fundamental, and issues into the three experimental tests referred to. The deflection of light in a gravitational field follows naturally, if gravitation is attributed to the heterogeneity of space-time. Any entity—whether light or matter—pursuing its natural path, will appear to change the character of its motion when the space-time through which it travels departs from the simple Euclidean type. It does not matter what the moving thing is; all that counts is the region through which it moves. The dilemma of the older theory does not exist from the relativistic point of view: light must be deflected or the theory must be abandoned.

Fortunately, the amount of the deflection which relativity demands is measurably different from that

which the electromagnetic theory allows. According to the relativity theory, a ray of light which just clears the sun's limb should suffer a deviation of about  $1''.75$ ; according to the other view, the deviation should be either half of this or nothing at all. It is this difference that makes possible the test which is about to be applied. On September 21 the sun will be leaving the constellation Virgo—very close to the celestial equator. The position is not so favourable with respect to neighbouring bright stars as was that of May 29, 1919, when the original test was made. On the other hand, the experience and criticisms arising from the previous attempt are available for the guidance of the present observers, and, granted favourable conditions, there seems to be no reason why the result should not become decisive.

### The British Association at Hull.

YORKSHIRE hospitality is proverbial, and it has been very pleasantly manifested during the meeting of the British Association just concluded at Hull. The citizens have in many ways shown themselves to be proud to entertain the Association, and the facilities they have offered to the members have been exceptionally helpful. Each member was provided with a badge, and this was not only a free pass on the quick and convenient tramway system of the city, but also secured personal guidance and interest from citizens in the streets or in vehicles of any kind. It would be impossible for a city to show greater interest in its visitors or to do more to make their sojourn pleasant, and the many attentions have been much appreciated, particularly by officers and other active members of sections who usually have not the time to search for all the amenities which a place of meeting may afford. A number of free luncheons have been provided, and when the days' meetings have been over tea has been served in the writing-room at the Guild-hall, and has been found both grateful and comforting to the members. For these and other unusual attentions the Association is no doubt chiefly indebted to the local secretary, Mr. T. Sheppard, curator of the Hull Museums, but with him is associated the town clerk, Mr. H. A. Learoyd, and the generous hospitality would not have been possible without the active interest and support afforded by the Corporation and people of the city. The Handbook to Hull and the East Riding of Yorkshire, edited by Mr. Sheppard and presented to each member, is a volume of permanent value, and as it will be on sale for the low price of five shillings we propose to publish a separate notice of it in an early issue.

At the meeting of the general committee at which the report of the council was presented, a resolution was passed conveying to Prof. Turner the most cordial thanks of the Association for the valuable services he

has rendered to science in general and the Association in particular during his nine years' work as one of the general secretaries. In its report the council stated that it had received with great regret Prof. Turner's intimation that he would not be able to attend a meeting in Canada in 1924. Prof. Turner himself pointed out that it was desirable, on various grounds, that his successor should have experience of the working of an annual meeting at home before taking part in one overseas, and he therefore placed his office at the disposal of the general committee as from the Hull meeting. The council and the Association owe a deep debt of gratitude to Prof. Turner for his unremitting care for the interests of the Association as general secretary since 1913, and therefore during a time of exceptional difficulty, including as it has the Australian meeting, the war, the revival of the annual meetings since the war, and the period when, on the death of the late general treasurer and assistant treasurer in 1920, he acted for some months as treasurer in addition to his other work.

Mr. F. E. Smith, director of scientific research at the Admiralty, and secretary of the Physical Society, accepted the invitation of the council to be nominated as Prof. Turner's successor, and the general committee unanimously voted his appointment to the office of general secretary of the Association. The three new members of the council appointed by the general committee are Mr. E. N. Fallaize, Dr. C. S. Myers, and Prof. A. Smithells.

Next year's meeting will be at Liverpool with Sir Ernest Rutherford as president, and in the following year the place of meeting will be Toronto. The invitation to Canada was conveyed by Prof. J. C. Fields and Prof. J. C. McLennan, and it was announced that a grant of about  $\text{£}1,000$ . would be available towards meeting the travelling and other expenses of visiting members.

### SUMMARIES OF ADDRESSES OF PRESIDENTS OF SECTIONS.

#### EQUAL PAY TO MEN AND WOMEN FOR EQUAL WORK.

IN Prof. F. Y. Edgeworth's address to Section F (Economics) the question whether the wages of men and women should be determined on the same

principles—in particular, through universal unrestricted competition—was discussed on purely economic grounds. Notwithstanding the general presumption in favour of *laissez faire*, it is maintained that some regulation is required for desperate competition tending to the

degradation of labour. Such kinds of competition being ruled out, there is advocated an equal labour-market, the same blend of competition and combination, for both sexes alike. The unequal pressure of male unions, crowding women into comparatively few occupations, is deprecated, and it is pointed out that a sufficient safeguard against such pressure is not afforded by the interest of the employer seeking to maximise his profits. This insufficiency is explained by a principle widely applicable in economics which may be stated thus. When a quantity is in the neighbourhood of a maximum value, a small change in the conditions on which it depends—the independent variables—is generally attended with a *very* small change in the dependent quantity. Some suggestions were offered with respect to the difficulty that the value of work is not always measurable without regard to the sex of the worker; e.g. the employment of a woman is less profitable, so far as, other things being equal, a man is generally more useful in an emergency. Lastly, Prof. Edgeworth considered the serious impediment to equality in the labour market caused by the burden of supporting a family which is commonly undertaken by men. The proposal to obviate this difficulty by the endowment of motherhood was examined; objection is taken to the (commonly implied) socialistic transference of enormous sums from one class to another. The objection is not equally directed against subsidies in kind for the purpose of education; nor against the proposal that within the same social grade, or association, the childless should contribute to the support of children.

#### DR. RIVERS AND THE DEVELOPMENT OF PSYCHOLOGY.

IN Section J (Psychology) the presidential address by Dr. C. S. Myers was "On the Influence of the late W. H. R. Rivers (President-elect of the Section) on the Development of Psychology in Great Britain." Rivers was invited in 1893 (in his thirtieth year) by Michael Foster to Cambridge, where he systematised the first course of practical work in experimental psychology in this country. His earliest experiments there were on colour vision and visual space perception, and he contributed to Schafer's "Textbook of Physiology" an exhaustive article on vision, which is still regarded as the most accurate and careful account of the subject in the English language. He soon extended his observations on colour vision and space perception to the Torres Straits Islanders, the Egyptians and the Todas, his membership of Dr. Haddon's Cambridge Anthropological Expedition to the Torres Straits giving him his first introduction to ethnology. These several investigations will ever stand as models of psychological method. In 1903, on his return from the Todas, he began his memorable share in the striking observations on the recovering cutaneous sensibility of Dr. Head's arm. The distinction therein reached between epicritic and protopathic sensibility laid the foundations of Rivers's later views on instinct, intelligence, dreams, and the unconscious. While working with Head, he was also engaged in studying the effects of alcohol, caffeine, and other drugs on muscular and mental work. These elaborate investigations he published as the Croonian

Lectures to the Royal College of Physicians in 1908. By them he advanced the pharmacological study of the effects of drugs on man, showing how important it is to disguise the drug and to provide a control mixture indistinguishable in taste from the disguised drug mixture, so as to avoid the complicating effects of suggestion, interest, and sensory stimulation. From 1907 to 1915 he confined himself to ethnological work, but during the Great War his treatment of the psychoneuroses in the Army and in the Air Force led him back to psychology. A period ensued in which Rivers's psychological genius was released from its former shackles and his intuition was no longer controlled by intellectual doubt. It is difficult to exaggerate the fruitful, stimulating character of his criticisms of Freud and of his views on the unconscious, on instincts, and on dreams which poured forth with such astonishing profusion during the last years of his life. His main object was to give a biological interpretation to the data of psychology. His wide interests, sympathies, attainments, and knowledge, his generosity and honesty, and his devotion to scientific methods inspire us in our common aim—the Advancement of Science.

#### ORGANISATION OF THE AGRICULTURAL INDUSTRY.

LORD BLEDISLOE, in his address on "The Proper Position of the Landowner in Relation to the Agricultural Industry," delivered before Section M, pointed out that organisation in the interests of the agricultural producer is the chief desideratum of British rural industry, and for this, enlightened leadership is essential. The leader and chief organiser should be the landowner, if he would but take his proper position after due training. Under present conditions it is evident that the unification of the rôles of the landowner and farm tenant is a condition precedent to the full, confident, and enterprising development of the agricultural industry on economic lines. Nevertheless, it must be recognised that the system of occupying ownership cannot exist in this country to the entire exclusion of that of landlord and tenant. English law and custom in relation to the settlement of estates and to the letting of farms are now frequently obstructive in nature under the changed conditions, and it might be well if modifications could be brought about—e.g., if it were made possible in certain cases to sell part of a settled estate in order to provide the necessary capital for the cultivation or industrial equipment of the remainder of it.

In all continental countries the political power enjoyed by agriculture is founded on the fact that it is an organised industry, whereas in Great Britain it is not. As a result, the continental landowner derives as a rule a net income of 3*l.*-4*l.* per acre, as compared with 1*l.* per acre in the United Kingdom. Much of this may also be attributed to the failure of the British farmer, in the absence of the landowner's stimulus, to utilise the results of education and research, whereas abroad, especially in Germany, more scientific methods are readily adopted, notably in the economic employment of feeding stuffs and fertilisers.

Many suggestions may be made as to methods whereby British agriculture, under the direction not

of the State but of the landowners, may be stabilised on a remunerative basis, among which may be mentioned the organisation of credit facilities, co-operative purchase and sale, utilisation of machinery and power, improvement of livestock sires, establishment of central dairies and bacon factories, the fuller exploitation of all farm products, especially in times of glut, and above all the elimination of superfluous and unnecessary middlemen. Apart from the heavy burden of local and Imperial taxation the toll levied by the middlemen is the main cause of the poverty-stricken condition of the English agricultural labourer; the disparity of the prices paid to the farmer and by the consumer for the same produce was well illustrated by tables.

During the last eight years occupying owners have increased by 49 per cent. and the acreage that they own by 100 per cent.; the political and industrial power resulting from this considerable reinforcement of their class should prove the greatest stimulus to enterprise on the part of landowners. The existence of the Central Landowners' Association is a welcome augury of future corporate efficiency, as its objects are to a great extent economic and constructive. In conclusion Lord Bledisloe emphasised once more the need for the effective organisation of agriculture and for the solidarity of all three classes of the agricultural community, without which continuous progress is difficult of attainment.

### Current Topics and Events.

THE Rowett Institute of Research in Animal Nutrition, Aberdeen, was formally opened by H.M. the Queen on Tuesday, September 12. It will be remembered that the Institute, which in the two years of its existence has done valuable work on problems of animal feeding, is under the control of the University of Aberdeen and the North of Scotland Agricultural College; the director is Dr. J. B. Orr. The Institute owes much to the generosity of Dr. J. Quiller Rowett, after whom it was named, who contributed a sum of 10,000*l.* towards its endowment (NATURE, September 9, 1920, p. 67). This was followed by another gift for the purpose of purchasing a farm which would allow of expansion of the Institute; H.M. Treasury, on the recommendation of the Development Commission, promised a further sum of 20,000*l.* It is the establishment of such institutions as the National Institute of Agricultural Botany and the Rowett Institute of Research in Animal Nutrition which will go far towards improving the unsatisfactory state of our knowledge of food problems, both animal and human.

To the August number of the *Nineteenth Century* Sir Arthur Keith contributes a timely article on the present position of Darwinism as applied to the problem of man's origin. The strange action of a strong party among the legislators of Kentucky in America, and ill-informed articles in certain American newspapers, have met with some feeble response in this country; and an authoritative statement of the case which can be understood by the general reader is especially needed at the present time. Sir Arthur Keith has stated the case admirably, and he emphasises the fact that if a new edition of Darwin's "Descent of Man" were prepared to-day, the work would merely need large additions, and scarcely any important revision. The discoveries of the fossil remains of man made since 1871 agree in pointing towards a common ancestry with the apes. The progress in our knowledge of human embryology within the same period has revealed a succession of facts which can be explained only on the theory of descent from lower forms of life. The latest discovery, that the development and growth of all parts of the body are regulated and co-ordinated by a "hormone"

(the pouring of substances into the circulating blood by the ductless glands), leads even to the hope that before long we may begin to learn something about the processes of evolution. To the investigator, indeed, Darwinism is not a mere theory, but an instrument of advance, trusted as implicitly as are the Admiralty charts by a navigator.

WE learn from the *Times* that an expedition headed by Capt. F. Hurley has left Sydney for Port Moresby with the object of exploring New Guinea from the air. The party will include an ethnologist and a naturalist. Two seaplanes are being taken and will be used in a four months' air survey of the western portions of British New Guinea. Meanwhile the scientific section of the expedition will navigate the Fly River in a ketch. The cost of the seaplanes is being borne by Mr. L. Hodson, of Sydney. Owing to the densely forested nature and steep slopes of the interior, exploration of New Guinea on foot is most arduous. Capt. Hurley's scheme promises some hope of success, but landing places, except along the coast, will be difficult to find. The leader's previous experience in exploration was obtained with the Australian Antarctic Expedition. He has also flown across the Australian continent.

THE earthquake reported on the morning of August 27 in the Midland Counties was possibly, as Sir George Fordham has suggested in the *Times*, caused by the bursting of a meteorite. A tremor and sound were observed at 9.12 A.M. (G.M.T.) over an area of about 650 square miles with its centre a few miles south of Birmingham; at Woodhouse Eaves, seven miles north-north-west of Leicester, at 9.13; and at Whissenthorpe, near Oakham, at 9.10. The observed times are so close that it seems probable that all three shocks were due to the same cause, and the detachment of the three areas and their nearly linear arrangement are certainly suggestive of successive explosions of a meteorite.

THE centenary of the Yorkshire Philosophical Society, which was founded in 1822, will be celebrated on Wednesday, September 20. The members of the Society and its guests will be received in the

gardens of the Yorkshire Museum by the president, Mr. W. H. St. Quintin, and a number of congratulatory addresses from national as well as local learned bodies will be read by their representatives. Later, the gathering will go in procession to the Minster, where a short service will be held and an address delivered by the Bishop of Beverley.

The following have been appointed to the Board of Trustees of the National Portrait Gallery: the Earl of Ilchester, Sir Martin Conway, and Mr. W. B. Hardy, in place of the late Viscount Bryce, Sir Edward Conway, and Viscount Harcourt, respectively.

The sixty-seventh international annual exhibition of the Royal Photographic Society of Great Britain will be opened on Saturday, September 16, by Mr. S. J. Solomon, president of the Royal Society of British Artists, at 35 Russell Square, W.C.1.

The Harveian Oration of the Royal College of Physicians of London will be delivered at the college at 4 o'clock on Wednesday, October 18, by Dr. Arnold Chaplin. Sir Maurice Craig is to deliver the Bradshaw Lecture (on "Mental Symptoms in Physical Disease") on November 2. The FitzPatrick Lecture will be given by Dr. R. O. Moon on November 7 and 9. The subject will be "Philosophy and the Post-Hippocratic School of Medicine."

It has been decided that an Institute of Paint and Varnish Technologists shall be founded, and a dinner is to be held shortly to inaugurate the new Institute. The objects of the Institute will be the dissemination of practical and scientific knowledge by reading and discussing papers, the improvement of technical education, the promotion of research, and the establishment of close relations with the Government and with societies interested in the products of the industry and their application. Applications to attend the inaugural dinner should be forwarded to H. D. Bradford, 42 Ribblesdale Road, S.W.16.

At a conference of the leading societies in North America that deal with biological subjects, recently held in Washington, it was decided to recommend to the constituent bodies the formation of a Federation of American Biological Societies. The members of the federation are to be societies, not individuals, and the governing body is to be a council consisting of two representatives from each society; the council is to choose an executive committee from its own members. One of the first questions to come before the council, if and when constituted, will be the improvement of biological publications, and a committee is already studying the question in co-operation with a committee from the Division of Biology and Agriculture of the National Research Council of the United States.

In our issue of April 15, p. 486, reference was made to the preparations in progress for the celebration in France of the centenary of the birth of Pasteur. A committee was formed in this country, under the chairmanship of Sir Charles Sherrington, in support of the commemoration measures, among which were

the promotion of an exhibition of hygiene and bacteriology in Strasbourg and the erection of a statue of Pasteur before the University. Various amounts have been sent to France from time to time by the British committee, in addition to which it is now stated that a sum of nearly 850*l.* is to be forwarded to the general treasurer of the fund, M. T. Héring. The British committee has expressed the wish that should the amount be greater than that the French committee desire to spend on the statue of Pasteur, the excess should be devoted to some other form of permanent memorial in the University of Strasbourg.

The programme has been issued of the meetings of the Institute of Metals to be held during the session 1922-23 under the presidency of Mr. Leonard Summer. The annual May lecture will be delivered on May 2 by Dr. W. Rosenhain. The Scottish Local Section, which has arranged for six meetings in Glasgow, will be under the chairmanship of Mr. James Steven; membership is open to all local members of the Institute, and applications should be addressed to the hon. secretary, Mr. H. H. A. Greer, 50 Wellington Street, Glasgow. The chairman of the Sheffield Local Section is Prof. C. H. Desch, and the hon. secretary, H. P. Gadsby, 193 Sandford Grove Road, Sheffield; an important event in the Sheffield programme is a joint meeting with the Faraday Society for a symposium on stainless and non-corrodible alloys to be held on February 9 at Sheffield.

The third International Conference of "Psychotechnique appliqué à l'orientation professionnelle" will meet this year at Milan on October 2-5. In order to prevent waste of time it has been decided to limit the discussions to the following subjects:— (a) What is meant by vocational aptitudes? (Lahy); (b) Natural aptitudes and acquired aptitudes (Décroly, Patrizi); (c) The psychological analysis of work (Gemelli, Lipmann); (d) Vocational guidance and Taylorism (Bauer); and (e) An international unification of tests and individual ratings (Claparède, Mira, Myers). A short paper of about twenty minutes' duration will be given on each subject in order to guide the discussion, and the language used will be French. The general session will be occupied with these subjects, but other meetings to discuss more detailed problems will be held in rooms specially set apart for the purpose. Papers presented at the meeting will be grouped together according to the relationship between them. A room will be reserved for the exhibition of tests, instruments, etc. Those desirous of attending are asked to communicate with the Secretary, III<sup>me</sup> Conférence Internationale de Psychotechnique, Milan (XIV.), via S. Barnaba 38. October 5 will be spent in visits to scientific and industrial establishments in the neighbourhood of Milan.

DR. M. J. SIRKS takes exception to the notice of his handbook of heredity published in NATURE of July 22, p. 111. He deprecates especially the charge of affirming that mutations have been actually pro-



duced as a direct consequence of changed conditions, and he adds, "I do not accept mutations at all, neither as a direct consequence of changed conditions, nor spontaneously, as being sufficiently proven." The writer of the notice regrets that he should have misrepresented Dr. Sirks's opinions. The criticism arose out of passages in chap. xiv., and referred in particular to the confident narration of Tower's alleged discovery of a sensitive period in the life of a beetle, during which its germ-cells could be modified by external conditions. Dr. Sirks summarised the account in a statement which may be translated thus. "In other words: without any doubt Tower succeeded, by means of very abnormal conditions of life, in breeding from the original form *Leptinotarsa decemlineata* offspring which had lost one hereditary factor; he called these 'mutants,' the name which is generally given to forms suddenly arising which exhibit hereditary variations." Nothing could be more explicit. In continuation, however, Dr. Sirks

definitely dissociates himself from the interpretation of the alleged new forms as mutants. The objection should therefore have been expressed differently. It was not the interpretation which seemed to the reviewer unfortunate or uncritical, but rather the unqualified repetition of sensational reports which, though they have attained some currency, are gravely in need of confirmation.

MESSRS. BENN BROS., Ltd., announce a new series of monographs dealing with gas and fuel. The first three volumes will be "The Administration and Finance of Gas Undertakings, with Special Reference to the Gas Regulation Act, 1920," by G. Evetts; "Gasworks Recorders," by Dr. L. Levy; and "Modern Gasworks Chemistry," by Dr. G. Weyman. The same firm will also publish shortly "Practical Optics for the Laboratory and Workshop," by B. K. Johnson, and "The Bronze Age and the Celtic World," by H. J. E. Peake.

### Our Astronomical Column.

SEPTEMBER METEORS.—Though September is not a month in which any rich shower of meteors is periodically visible, a considerable number of meteors and many radiant points of moderate activity should be seen. Fireballs are also particularly abundant during the month, especially on September 13-15, and again on September 24-28. The principal systems of meteors at this time of the year radiate from Aries, Perseus, Auriga, and other constellations in that part of the heavens. At the middle of September there is usually a strong display of  $\epsilon$  Perseids from  $61^\circ + 36^\circ$ ; there is also a prominent shower from near  $\alpha$  Cygni, at  $314^\circ + 48^\circ$ , and swift, streaking meteors from the Lynx frequently manifest themselves. September is, in fact, usually a productive period for the meteoric student, and further watching may reveal a somewhat rich annual display that hitherto has not received the notice it merits.

INVISIBLE SUNSPOTS.—In the year 1908 Dr. G. E. Hale published (Contributions from the Mount Wilson Solar Observatory, vol. i., No. 26) his discovery of solar vortices. This vortex hypothesis assumes that a sunspot resembles a vast tornado in which electrified particles, due to ionisation in the solar atmosphere, are rapidly whirled. The invariable presence of a magnetic field, caused by the revolving charges, confirmed this view, but it was also supported by other results of observation with the spectrograph and spectroheliograph. It was found also that most sunspots were associated in pairs of opposite magnetic polarity, and 61 and 33 per cent. respectively of 970 spots were observed as bipolar and unipolar. The fact that some groups oscillated between unipolar and bipolar types, one or more small spots appearing and disappearing within the mass of calcium flocculi, suggested to him the idea of looking for invisible spots. That these might be found seemed most probable, there being vortices giving appreciable magnetic fields without any actual visible sunspots. Dr. Hale now describes his recent investigation in this direction (Proc. Nat. Acad. of Sciences, U.S.A., vol. 8, No. 7). The method he adopts is a device for rendering feeble magnetic fields visible by the Zeeman effect, and details of the procedure are given in his paper. Suffice it to say that he has found a great number of cases in which

a local magnetic field was observed where no spot was recorded. He points out the importance of making systematic observations of invisible spots, especially during the periods preceding and following the visible life of those that reach maturity, in order to assist in revealing the cause of sunspot formation.

ABSOLUTE MAGNITUDES OF STARS.—Several years ago Prof. H. N. Russell produced a striking diagram of absolute magnitudes, on which the theory of giant and dwarf stars was based; it met at first with some opposition, but has gradually won its way to general acceptance. The number of stars of which trustworthy parallaxes (photographic, spectroscopic, and hypothetical) have been obtained, has now been greatly increased, and Dr. Heber D. Curtis has prepared a revised diagram, which is reproduced in the Journal of the R.A.S. of Canada for July-August. It contains 2375 stars, and shows the division into giants and dwarfs very plainly. The gap between them is complete in type M, but begins to be filled by a few stragglers in type Ko, suggesting that this may be the maximum temperature attained by stars of small mass. In types G and K the giants outnumber the dwarfs, but the reverse holds in type F. The giants here are comparatively few, but they include some of remarkable luminosity.

Broadly speaking, the regions of maximum frequency form two straight lines; that of the giants forms a horizontal line at magnitude  $+1$ ; that of the dwarfs slopes downwards from  $+1\frac{1}{2}$  at type Ao (the giants and dwarfs being here mingled) through  $+5$  at type G5 (so that the sun is an average star of its type) down to 8 or 9 for Ma.

The diagram suggests to Dr. Curtis the conclusion that a sensible number of B-stars have parallaxes of the order of  $0''.02$ ; he notes that stars of this type are being put on the working lists at the Allegheny and Leander McCormick Observatories. These stars cannot as yet be investigated for parallax by the spectroscopic method, so that the results of these measures will be awaited with interest. It will be remembered that the results have a bearing on the adopted distances of the globular clusters. The fainter the absolute magnitude found for the average B-star, the nearer we must put the clusters.

## Research Items.

**LAUGHTER.**—In the *Fortnightly Review* for August J. A. T. Lloyd considers the problem of humour and mechanism. Bergson in his well-known study, "Le Rire," maintains the hypothesis that the essence of humour lies in the mechanisation of what ought to be spontaneous and not mechanical. The function of laughter is to punish and so to prevent the repetition of machine-like behaviour. The author of this paper criticises this point of view as being more true of Latin humour than of Anglo-Saxon and supports the theory that in the case of the latter, laughter is rather due to a feeling of superiority. He thinks, however, that recently a change has taken place, and that in Mr. Stephen Leacock's humour we approximate to humour as sensed by Bergson; he detects automata masquerading as human beings and we laugh, but not with the old laughter of superiority. A more fundamental treatment of the subject of laughter will be found in *Psyche* (vol. ii. No. 4), where Prof. McDougall develops at greater length a theory he put forward in *NATURE* some years ago. He believes that the theories usually advanced fail to answer the question, For what end did the human species acquire the capacity for laughter? Man is endowed naturally with the tendency to share the emotions of others, when he sees them expressed by them in action, thus rendering himself extremely susceptible to the suffering he sees around him. Were he to suffer sympathetically every pain he saw, he would very rapidly devalue himself; hence he has developed a compensatory mechanism whereby he laughs at the pains and sufferings which are not serious or with which he can have no concern. Laughter is then primarily and fundamentally the antidote to sympathetic pain. It is necessary to distinguish laughter from the smile which is the natural expression of pleasure.

**RADULA OF THE HELICINIDÆ.**—This, judging from the somewhat jejune remarks concerning the method of preparation and mounting and seeming want of acquaintance with the work of earlier writers on the subject, appears to be the author's first encounter with the molluscan radula. In these circumstances, Mr. H. B. Baker (Proc. Acad. Nat. Sci. Philad. vol. lxxiv.) must be held to have acquitted himself well and has rendered a useful and well-illustrated account of the radula of the Helicinidæ that will prove useful to future students of the group. Although the title gives no hint of the fact, the author attempts a classification of the North American Helicinidæ largely based on the characters of the operculum, and further essays a phylogenetic scheme.

**THE STRUCTURE AND BIOLOGY OF THE HOG LOUSE.**—Memoir 51 of the Cornell University Agricultural Experiment Station, by Miss L. Florence, is devoted to a study of this insect and forms a carefully executed piece of morphological work. With the exception of the human louse, very few detailed studies have been made of any species of Anopleura, and the present paper fills a very noticeable hiatus. The complete life-cycle from egg to egg at a temperature of 35° C., followed out in vials worn next the body, was ascertained to require 29 to 33 days. Of this period 13-15 days was occupied by the incubation of the eggs and three ecdyses were passed through during post-embryonic life. The difficult subject of the mouth-parts is very fully discussed, but their homologies are not touched upon more particularly owing to the necessity for developmental studies made upon

the embryo. The only investigator who has dealt, so far, with this aspect of the subject is Cholodkovsky, in his work on *Pediculus*. Miss Florence finds that the pharynx and mouth-parts of the hog louse are similar in plan to those of the last-mentioned insect. The result of the work, as a whole, is to emphasise the general morphological similarity of the Mallophaga and Anopleura, thereby supporting the conclusions of Mjoberg and of Harrison.

**RESEARCHES ON DIPTERA.**—In Bulletin No. 5 (n.s.) of the Canadian Department of Agriculture, Dr. A. E. Cameron contributes a well-illustrated paper on the structure and biology of *Simulium simile*, a small black fly infesting cattle in Saskatchewan. This insect, however, has not been observed to suck the blood of man, although it may cause mild annoyance to human beings by flying persistently around their heads. The aquatic larvæ and pupæ of this species are extensively preyed upon by a fish known as the sucker (*Catostomus commersonii*), which is proving itself one of the most successful controlling agents. As the result of experimental tests with miscible (phintas) oil it is shown that the *Simulium* larvæ can be killed. The experiments, however, did not prove to be quite so satisfactory with the larvæ of *S. simile* in the river as with those of other species in a small stream. In *Bulletin of Entomological Research*, vol. 12, Part 4, Major W. S. Patton contributes revisionary notes on the genus *Musca*: in this first part of the paper he deals with Oriental and Australasian species. The rôle which these insects play in the dissemination of disease renders the exact determination of very closely allied species a matter of practical importance. Mr. F. W. Edwards (*Entomologist's Monthly Magazine*, July) describes a new species of Sciarid fly, *Platostociara pernicioso*, the larvæ of which were found damaging cucumber roots and stems in a nursery at West Worthing, where they were present in very large numbers.

**MANGANESE IN PLANT NUTRITION.**—Since the discovery of manganese in the soil and in plant ashes by Scheele in 1774, numerous investigations have been made on the occurrence, distribution, and probable function of this element in its relation to agriculture. In the July number of the *Journal of the American Chemical Society*, Mr. J. S. McHargue, of the Kentucky Agricultural Experiment Station, describes a careful series of experiments, with purified materials (lack of care in this respect having caused errors in previous work), the results of which seem to point definitely to the conclusion that manganese has a function to perform in the production of chlorophyll, and consequently in carbon assimilation and possibly in the synthesis of protein.

**FORMATION OF MARINE DEPOSITS ABOVE SEA-LEVEL.**—The Report of the Secretary of the Smithsonian Institution for 1921 quotes some observations made by Dr. Paul Bartsch at the south-east point of Hanouma Bay, Hawaii, where he found a marine flora and fauna living at a considerable elevation (the precise height not given) above the level of the sea. Algae, molluscs, crustaceans, echinoderms, and other marine organisms, says Dr. Bartsch, "occupy pools and puddles kept moist and supplied with fresh water by the spray from the breaking surf, which incessantly pounds that shore. I consider this an important observation, since the occurrence of fossiliferous laminae bearing marine organisms between sheets of lava has been held to indicate that they

were deposited at or below sea-level, and their occurrence above this has been held as evidence of elevation. We have here an instance which indicates that this is not necessarily the case, for such a lamina would be produced if a new outpouring of lava were to cover up the place mentioned."

**CENOZOIC FISHES OF CALIFORNIA.**—In a paper on the fossil fishes of the diatom beds of Lompoc, California (Leland Stanford Junior University Publications, 1920), David Starr Jordan and James Zaccheus Gilbert direct attention to beds of Miocene age, probably formed in a quiet, shallow, marine bay; they are rich in large diatoms and "heavy" radiolaria. At one special horizon an extinct herring, *Xyne grex*, is represented by an immense number of individuals, all adult, all about six inches long, and unmixed with any other fish. They appear to have entered the bay with the view of spawning, and to have been killed suddenly "with no evidence of agony or distortion." In a subsequent paper, on "The Fish Fauna of the California Tertiary" (Stanford Univ. Publications, Biol. Sci., vol. i. No. 4, 1921), Dr. Jordan gives very interesting restorations of a number of fossil fish in a series of captivating plates, preceded by photographs of their skeletons. He refers again to the remarkable shoal of herring, which provides 8 or 10 specimens to the square foot over an area of four square miles. It is estimated that 1200 million individuals perished on this one occasion. Though it is said that Dr. Mann has offered an explanation, we are unable to trace it in these memoirs.

**CARBON-BLACK IN THE UNITED STATES.**—Recent articles in NATURE have directed attention to the various products obtainable from natural gas, among which petroleum, allied light oils, and helium figure prominently. An important industry also exists for the purpose of manufacturing carbon-black from this source, this product forming the basis of such commodities as printers' ink, paints, varnishes, polishes, cement colours, etc. It is also considerably used in the rubber industry for increasing the resiliency and toughness of rubber tyres. The processes of extraction of carbon-black from natural gas are confined principally to the United States, Louisiana being the leading state in this respect, the other producing states being West Virginia, Kentucky, Oklahoma, Pennsylvania, Montana, and Wyoming. The industry thrives best where there is an abundant supply of natural gas available in fields sufficiently isolated as to inhibit the use of the gas for domestic purposes. The yield of carbon-black per thousand cubic feet of gas ranges from 0.2 lbs. to 3.5 lbs., and in 1921 more than 31 million pounds were produced by Louisiana alone, the average yield being 0.97 lbs. per m. cub. feet. The total production for the United States for that year amounted to 59,766,315 lbs., valued at 5½ million dollars (E. G. Sievers, Min. Resources Unit. States, 1921, pt. ii. p. 33). Recent legislation in some states, in particular Louisiana, has tended to check the progress of this industry, since the rapid advancement of natural gas gasoline manufacture (a far more valuable product) has resulted in the conservation of natural gas for that purpose. Operators are therefore compelled to extract the gasoline from the gas before the latter is burned in the carbon-black plants. In some cases this has served to eliminate the industry altogether, but by adapting and by using the gasoline and carbon-black plants in conjunction, such calamity can be, and is being, fortunately avoided.

**THE COURSE OF PHOTOGRAPHIC DEVELOPMENT.**—Forty-five years ago, Abney (*Phil. Mag.*, 1877) coated exposed plates with a second sensitive film before

development. After development he stripped off the second film and found that a part of the image was in it—that is, the development had spread from the exposed to the unexposed sensitive material. On the contrary, common experience with gelatine plates shows conclusively that when the exposure is insufficient it is impossible to develop an image of the maximum density that the plate can yield. If development spreads at all from exposed to unexposed particles, the spreading effect must be very limited. Recently, this matter has been investigated in the modern, microscopical manner, by tracing the changes in the particles themselves. Prof. The. Svedberg has shown that developability is not conferred by developable grains upon contiguous grains, and that the percentage of grains developed is not increased when the grains are "closely packed together." In the September number of the *Journal of the Royal Photographic Society*, Messrs. A. P. H. Trivelli, F. L. Righter, and S. E. Sheppard, of the Research Laboratory of the Eastman Kodak Company, give details of their experiments, which show that where a group of two or more grains forms a "clump," this clump develops as a unit, and if only one of the constituent grains has been made developable, the whole group is completely developable. They used Svedberg's methods. They consider that Svedberg's results are conclusive evidence that developability in his case was not transferred from one grain to another, and ascribe their apparently contradictory results to the character of the emulsion. Svedberg used a special emulsion with mostly spherical grains of nearly uniform size, while the authors' emulsion had a wide range of grain sizes and contained many large polyhedral tablets. Obviously this matter is of fundamental importance from a theoretical point of view.

**UPPER AIR RESEARCH.**—Part I. of an aerological survey of the United States, the results of observations by means of kites, by Mr. W. R. Gregg, is published as Supplement No. 20, U.S. *Monthly Weather Review*. An abstract by the author is also given in the *Monthly Weather Review* for May last. The object of the discussion is to furnish results so much needed at the present time in connexion with aviation and ordnance. Much detailed information can be obtained from the numerous tables and diagrams as to the characteristics of the free air over the United States east of the Rocky Mountains. Kite observations are made at six stations established by the Weather Bureau during the period 1915 to 1918, and there are data from other sources. Various meteorological results for the upper air are given for the several months, the season, and the year. The values at Blue Hill, Mass., and Mount Weather, Va., each based on a long series of observations with kites, are included in the discussion. Free-air results will augment the general knowledge of atmospheric circulation, and of the movements of cyclones and anticyclones. It is rightly claimed that they will give information of value in connexion with the laying out of a permanent flying course or "air-way." Near the surface the turning of the winds is generally to the right, and the deviation is greater in winter than in summer; moreover, it is greater at northern than at southern stations. The average wind velocity at lower levels increases most above surface south-easterly to south-westerly winds, but at greater heights the largest increases are found above surface south-westerly to north-westerly winds. The velocities are least in all seasons and at all heights above surface north-easterly to east-south-easterly winds. A review of pilot-balloon observations is foreshadowed at a future date.

## Einstein's Theories.

THE *Revue Philosophique* (Alcan, Paris), edited by Prof. Lévy-Bruhl, has just issued (July-August) a special number devoted to the consideration of Einstein's theories of relativity. It consists of four articles of exceptional ability and importance, all directed to the philosophical aspects of the problem. That Einstein's theory is established, in the meaning that it is applicable in physical science, is accepted by each of the writers, and their aim is to decide how far it forces upon us a new way of thinking about physical reality.

The first article is a translation by M. Léon Bloch from the German of Hans Reichenbach, "La signification philosophique de la théorie de la relativité." The philosophical interest centres on the concept of time. Must we give up the absolute meaning of simultaneity? If we do, the Michelson-Morley experiment at once ceases to be incomprehensible, light can have the same velocity in the moving system which it has in the system at rest. But can we give up absolute simultaneity without being involved in logical difficulties and finding ourselves confronted with a pure paradox? In a very skilful argument the writer concludes that we can and that we must. Relativity is both a logical necessity and an experimental fact. This leads to the consideration of the part played by the velocity of light in Einstein's theory.

In Nature the electromagnetic waves play a unique part and are of greater importance than any other phenomenon which serves us as a signal. They alone (if we set aside gravitation) transmit an action across empty space. Now as the forces which the individual particles of matter exercise on one another are of the same nature as electromagnetic forces, it follows that all propagation of material action resolves itself ultimately into an electrical transmission.

The essential ideas of the theory of relativity were forestalled by Ernst Mach forty years ago, and Einstein is continually reminding us of our indebtedness to him. The idea that movement as a spatial phenomenon can be recognised only in relation to other bodies was much older—we have it, for example, in Descartes and in Leibniz—but what distinguishes Mach's point of view is the idea that

movement must have not only kinematic but also dynamic relativity, that what we call the forces of inertia must be bound up with the presence of other bodies. In Mach, however, the relativity of theory of knowledge is not distinguished from physical relativity; it remained for Einstein to show that the actions of movements, or what we name forces, can be reduced to a difference between the distributions of masses.

The second article, by M. G. Cerf, "Pour l'intelligence de la relativité," deals particularly with the exact meaning we are to give to the terms employed in the theory, and the writer draws largely on the works of Henri Poincaré.

The third article, "Einstein et la métaphysique," is by M. Edmond Goblot, the distinguished logician and philologist. He finds considerable amusement and no little instruction in the popularisers of Einstein, more especially those who competed for the Higgins prize of the *Scientific American* Publishing Co. In his conclusion he says: "Je résume et précise ma question: Einstein est-il mathématicien, physicien ou métaphysicien? Mathématicien il l'est. Physicien il l'est aussi. S'est-il borné à cela, ou s'est-il abandonné aux débauches de métaphysique inconscient qu'on nous fait lire en son nom? Dans les deux cas, il est grand temps d'exorciser tous ces fantômes."

The fourth and concluding article, by M. Richard-Foy, "Le temps et l'espace du commun sens," is a very clear statement of the whole problem to meet which the new principle is required. It deals mainly and sympathetically with M. Painlevé's protest against the refusal to allow any place for the concept of an absolute in physics. The rejection of time and space as absolutes is not irreconcilable, he argues, with such a position. To say that time, space, and movement are not absolutes means that, instead of being realities which impose their laws on phenomena, they are only abstractions, necessary to express those laws, but capable of assuming the most diverse forms. We choose among these forms with the simple aim of discovering the most convenient, but our choice has limits. For example, we cannot define simultaneity in any two points absolutely, yet we must define it so that it is not possible that my friend has read my letter to him before I have written it.

## Educational Work of the Ministry of Agriculture.

THE Intelligence Department of the Ministry of Agriculture and Fisheries has issued a Report on the work of the department for the years 1919-1921, which is published at the price of 5s. by H.M. Stationery Office. The duties of this department are concerned with agricultural education, agricultural research, the agricultural training of ex-officers and men, horticulture, the improvement of live-stock, the destruction of rats, and the diseases of animals.

Agricultural education is provided through the agency of colleges, including agricultural departments of universities, and by farm institutes, local classes, and lectures. The first group comprises eleven institutions, of which all, except the Harper Adams, the Midland Agricultural College, the University College, Reading, and the Seale Hayne College, are connected with universities in which students may obtain a degree with agricultural science as their chief subject. In most cases the agricultural department

is actually part of the university organisation, and it is recognised that in many respects this is an ideal arrangement. Agricultural students thereby obtain the intellectual stimulus that is associated with intercourse with students in other faculties. Future teachers, scientific workers, and agricultural experts all gain by the indefinable atmosphere which pervades a university course. On the other hand, it has been found that although, theoretically, expenditure should be saved by taking advantage of the courses in general science which a university provides, in actual practice it has proved necessary to provide special teaching even in preliminary scientific subjects designed for agricultural students.

By means of this special teaching an agricultural flavour is imparted to chemistry, botany, zoology, or whatever the fundamental science may be, and thus from the very beginning the student's interests are awakened and stimulated. Against such an arrange-

ment it has been urged that association with other students tends to divert a certain number of agricultural men to other subjects. But it is probable that an agricultural department of a university tends to attract more men than it loses. The courses provided in university departments of agriculture are intended for the education of future landowners, land agents, and large farmers, but for investigators it is found best that they should pass through an honours school in pure science before taking up the study of the application of science to agriculture. The report lays special emphasis on the need for the study of accountancy, which in its application to costs of production may be a powerful instrument in determining the economic success of a farm.

It is pointed out that the cost of providing the necessary staffs in a university or college is now so great that it is impossible for each college to provide highly specialised instruction in every branch of agricultural education, but that extreme specialisation must be left to individual colleges. Again, tutorial instruction and encouragement of private reading are urged as a means of relieving pressure on formal lectures, and so of keeping down expenses.

While agricultural departments in universities and agricultural colleges are the agency of providing instruction to prospective landowners, large farmers, and public servants, the needs of the ordinary farmer's son are best supplied through farm institutes. The latter have been developed in recent years as the result of the recommendations of Lord Reay's Committee which in 1905 strongly urged their creation. These farm institutes are under the authority of County Councils, directed by the Ministry of Agriculture. An agricultural education committee having been set up, it submits its scheme to the ministry, and this, if approved, is supported by grants. The staff of an institute consists in most cases of an organiser, a director of agriculture, and certain teachers. The county organiser is usually the head of the farm institute, and towards his salary the ministry may contribute as much as four-fifths. It also pays annual grants up to two-thirds of the total general expenditure. Classes are provided as a rule for twenty-four weeks during winter, at a time, namely, when young farmers can leave their farms and devote their time to study. While a certain amount of manual training is possible at farm institutes, it is recognised that the best place for getting such instruction is on the farm of the student's father. The teaching of science is in close contact with practice, and is concerned principally with such subjects as varieties of crops, methods of cultivation, rotations, manures and feeding stuffs, principles of feeding and breeding, dairying, poultry, and farm book-keeping. Such farm institutes have been established in Cumberland, Essex, Hampshire, Carnarvonshire, Monmouthshire, Cheshire, Hertfordshire, Northamptonshire, Somerset, Staffordshire, Suffolk, and Denbigh, while others are contemplated in Durham, Kent, Carmarthen, West Sussex, and the Holland Division of Lincolnshire.

Besides providing instruction for students, the colleges and institutes are intended to serve as advisory centres for farmers generally. Such advisory officers are usually specialists in plant pathology, botany, chemistry, and general agriculture, and to these farmers are encouraged to turn in case of difficulty. This they are doing in increasing numbers every year, and one of the most gratifying features of the present position is the disappearance of prejudice on the part of cultivators to education and science.

## University and Educational Intelligence.

ABERDEEN.—Mr. G. P. Thomson, lecturer in mathematics at Corpus Christi College, Cambridge, has been appointed professor of natural philosophy in succession to Prof. C. Niven, who has retired.

LEEDS.—The honorary degree of Doctor of Science has been awarded to Prof. A. F. Holleman, of the University of Amsterdam.

PROF. CHARLES CROWTHER has been appointed Principal of the Harper-Adams Agricultural College, Newport, Salop, in succession to Mr. P. Hedworth Foulkes, who has been Principal since the College opened in 1900.

AN important conference of representatives of British and Swiss universities took place at Basle last month. There were present fifteen delegates from Great Britain and Ireland, Oxford being represented by the Vice-Chancellor and the Warden of All Souls, Manchester by the Vice-Chancellor and Prof. T. F. Tout, Edinburgh by Sir Richard Lodge and Prof. J. Mackinnon, and Birmingham, Bristol, Cambridge, Leeds, London, Wales, St. Andrews, Dublin, and the National University of Ireland each by one delegate. Each of the seven Swiss cantonal universities was represented. At the three formal sessions of the conference, held on August 22 and 23 in the great hall of the University, the topics of discussion were the recognition by the British universities of university entrance examinations passed, university studies pursued, and degrees conferred in Switzerland, and *vice versa*, and interchange of university teachers. Of perhaps even greater importance than the formal discussions were the conversations for which ample opportunities were provided in the course of the numerous social functions at which the visitors were entertained. The Federal Ecole Polytechnique of Zürich was unfortunately not represented at the conference. Before the war this institution, like the cantonal universities, drew a large proportion of its students from other countries where economic conditions are at present unfavourable to the migration of students to Switzerland. Consequently there are plenty of vacant places in its laboratories, which are well equipped for advanced work in, for example, industrial chemistry and electrical engineering.

A PROVISIONAL programme has been issued by the Sociological Society, Leplay House, 65 Belgrave Road, Westminster, S.W.1, of a conference on the correlation of the social sciences, which it is proposed to hold at Oxford on October 7-9. The conference will not be open to the public, but invitations are being issued to members of the Sociological Society and to representatives of the social sciences from the universities of Great Britain. The object of the conference is to provide an opportunity for the discussion by specialists of various branches of social science with the view of co-ordination. Mr. F. S. Marvin (history), Sir Halford Mackinder (geography), Mr. Julian Huxley (biology), Prof. C. E. Spearman (psychology), Prof. L. T. Hobhouse (philosophy), Dr. R. R. Marett (anthropology), Prof. J. E. G. de Montmorency (law), and the Rev. A. J. Carlyle (political science), will probably address the conference, dealing with the various aspects of sociology named.

## Calendar of Industrial Pioneers.

September 17, 1823. **Abraham Louis Breguet died.**—The foremost horologist of his day, Breguet was born in Switzerland in 1747, but at an early age removed to Paris, where he became a member of the Bureau des Longitudes and of the National Institute. He is remembered for his improvements in the escapement of watches and his invention of the sympathetic pendulum and of a sensitive metallic thermometer.

September 17, 1869. **John Elder died.**—One of the greatest marine engineers, Elder was trained under his father, David Elder, at Napiers'. In 1852, at the age of twenty-eight, he joined the engineering firm of Randolph Elliott and Co. and became the virtual founder of the great firm at Govan known since 1886 as the Fairfield Shipbuilding and Engineering Co. He was one of the first engineers to grasp the importance of the new science of thermodynamics, and he successfully introduced the use of the compound engine at sea, thereby effecting a saving of 30 to 40 per cent. of the coal burnt. The Elder chairs of naval architecture at Glasgow and at Liverpool were founded respectively by his widow and his brother Alexander, who died in 1915.

September 17, 1895. **Johann Sigmund Schuckert died.**—After working as a mechanic in various towns of Germany, Schuckert spent some years in America, where he became acquainted with Edison, and on his return home, in 1873, set up a workshop at Nürnberg. He then began the manufacture of dynamos and other electrical machinery, and became one of the best-known electrical engineers in Germany.

September 18, 1860. **Joseph Locke died.**—Born near Sheffield in 1805, Locke gained his first experience of railway engineering under George Stephenson on the Manchester and Liverpool Railway. Afterwards by himself, or with his partner Errington, he built many of the early railways, including those between Manchester and Sheffield, and London and Southampton, and the line from Paris to Rouen and Havre. His railways were notable for the absence of great and expensive works. From 1857 till his death he was President of the Institution of Civil Engineers.

September 19, 1890. **Leon Bourdelles died.**—An engineer of the Corps des Ponts et Chaussées, Bourdelles rose to be head of the Lighthouse Department, in which situation, by the display of uncommon energy and resource, he revolutionised the lighting of the French coast, increasing the aggregate candle-power from 4,000,000 to nearly 100,000,000 without increasing the annual cost.

September 20, 1885. **Walter Weldon died.**—The son of a Loughborough manufacturer, Weldon became a journalist in London. Turning his attention to practical chemistry, he sought means of recovering the manganese peroxide used in the manufacture of chlorine, and about 1868 patented the lime-manganese process, which reduced the cost of bleaching powder by 6l. a ton and added something like 750,000l. per annum to the national wealth.

September 22, 1852. **William Tierney Clark died.**—A well-known civil engineer, Clark for forty years was engineer to the Middlesex Water Works. His masterpiece was the great bridge erected across the Danube at Budapest in 1830-40 at a cost of 622,000l.

September 23, 1878. **John Penn died.**—For many years Penn was the leading marine engine builder on the Thames. He invented the lignum vitæ stern bush bearing for screw ships, and during the Crimea War he organised the manufacture of the engines for gunboats, completing 90 sets of engines of 60 n.h.p. each in ninety days, the first example of mass production of machinery for warships. E. C. S.

## Societies and Academies.

## PARIS.

**Academy of Sciences, August 16.**—M. Émile Roux in the chair.—M. de Sparre: Remarks on the depressions resulting from a breakage in a water main under pressure.—Kyrille Popoff: The integration of the equations of ballistics under general conditions of resistance.—Pierre Auger and Francis Perrin: The shocks between  $\alpha$ -particles and atomic nuclei. An application of a modification of C. T. R. Wilson's method of studying the paths of  $\alpha$ -rays. Photographs of the paths were taken with two cameras at right angles to each other, and details of results in argon and in hydrogen are given. For argon the value of the atomic number calculated from the results of the observations is 19 (instead of 18).—I. Newton Kugelmass: A new apparatus, the nephectrometer. The change in the transparency of a colloidal solution is measured by the deflection of a millivoltmeter connected with a thermocouple. The light from an electric lamp, after passing through a cell containing distilled water, is allowed to fall on the thermocouple for a fixed time, and the deflection of the millivoltmeter measured (I). The water is then replaced by the colloidal solution and the deflection ( $I'$ ) measured under the same conditions. The ratio  $I'/I$  gives the transparency index.—A. Marcelin: Measurement of the pressure of "superficial fluids." Detailed study of oleic acid.—F. Granel: The morphological signification of the pseudobranch of the teleosts.

## Official Publications Received.

Union of South Africa, Department of Mines and Industries: Geological survey. The Geology of the Country around Heidelberg. By Dr. A. W. Rogers. Pp. 84. The Geological Map of the Country around Heidelberg. (Pretoria: Government Printing and Stationery Office.) Price, including Map, 8s. 6d.

Air Ministry: Meteorological Office. British Meteorological and Magnetic Year Book, 1918. Part IV.: Hourly Values. (From Atmospheric Reports, 1918. Pp. 73. (London: H.M. Stationery Office.) 17s. 6d. net.

Sultanic Agricultural Society: Technical Section. Bulletin No. 1: A Survey of the more Important Economic Insects and Mites of Egypt. By F. C. Wilcocke. Pp. viii+483. (Cairo: Sultanic Agricultural Society.)

Guide to the Australian Ethnological Collection exhibited in the National Museum of Victoria. By Sir Baldwin Spencer. Third edition. Pp. 142+33 plates. (Melbourne.)

Edinburgh and East of Scotland College of Agriculture. Calendar for 1922-1923. Pp. 77. (Edinburgh.)

The North of Scotland College of Agriculture. Calendar, Session 1922-23. Pp. viii+145. (Aberdeen.)

The North of Scotland College of Agriculture: County Extension Department. Report on County Extension Work, 1921-22. Pp. iv+52. (Aberdeen.)

Ministerio da Agricultura, Industria e Commercio: Directoria de Meteorologia. Boletim Meteorologico: Anno de 1914. Pp. vi+121. (Rio de Janeiro.)

Report of the Government of Agriculture for the West Indies. Report of the Agricultural Department, Antigua, 1920-21. Pp. iv+19. (Barbados.) 6d.

Memoirs of the Indian Meteorological Department. Vol. 23, Part 4: The Effects of Oscillations and of "Lag" on the Readings of the Kew Pattern Barometer. By Dr. E. P. Harrison. Pp. 137-144+2 plates. (Calcutta: Government Printing Office.) 1s. 8 rupees; 2s.

Report on the Operations of the Department of Agriculture, Madras Presidency, for the Official Year 1920-21. Pp. ii+28+4. (Madras: Government Press.) 4 annas.

Report of the Government Chemist upon the Work of the Government Laboratory for the Year ending 31st March 1922: With Appendices. Pp. 33. (London: H.M. Stationery Office, 1922.) 1s. 6d. net.

Museums of the Brooklyn Institute of Arts and Sciences. Report upon the Condition and Progress of the Museums for the Year ending December 21, 1921. By Wm. Henry Fox. Pp. 56. (Brooklyn, N.Y.)

Rendiconti delle Sessioni della R. Accademia delle Scienze dell' Instituto di Bologna. Classe di Scienze Fisiche. Nuova serie, Vol. 21, 1919-20. Pp. 152+xxviii. Nuova serie, Vol. 25, 1920-21. Pp. 155+xxxv.

Prospectus of University Courses in the Municipal College of Technology, Manchester, Session 1922-23. Pp. 219. (Manchester.)

Air Ministry: Meteorological Office. International Meteorological Committee. Report of the Eleventh Ordinary Meeting, London, 1921. And of Meetings of the Commissions for Weather Telegraphy, Maritime Meteorology, Aerial Navigation, Rescue Mondial, and Polar Meteorology. (M.O. 218.) Pp. 128. (London: H.M. Stationery Office, 1922.) 4s. 6d. net.

# NATURE

A WEEKLY ILLUSTRATED JOURNAL OF SCIENCE.

*"To the solid ground  
Of Nature trusts the mind which builds for aye."*—WORDSWORTH.

No. 2760, VOL. 110]

SATURDAY, SEPTEMBER 23, 1922 [PRICE ONE SHILLING

Registered as a Newspaper at the General Post Office.]

[All Rights Reserved.]

## NEWTON'S EPISCOPE

for the projection of  
OPAQUE OBJECTS

including  
MAPS, DRAWINGS,  
DIAGRAMS, PRINTED  
and TYPED MATTER,  
ILLUSTRATIONS,  
NATURAL OBJECTS,  
etc.

*Price list on application.*

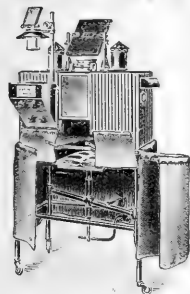

Opticians to H.M. the King. **NEWTON & CO.** Estab. over 200 years.  
*Specialists in Optical Projection Apparatus for Visual Instruction.*  
72 WIGMORE STREET, LONDON, W.1.

## REYNOLDS & BRANSON, LTD.

Chemical Glassware, Chemical and Physical Apparatus Makers to His Majesty's Government (Home and Overseas Dominions), Laboratory Outfitters, &c.

Gold Medals at Allahabad and London. Grand Prix and Gold Medal at the International Exhibition, Turin.

### STROUD & RENDELL SCIENCE LANTERN.

The "University" Lantern, with Russian iron body, sliding baseboard, two superior objectives, with rack and pinion for focussing, condensers 4½ in. diam, plane silvered mirror "A," which is moved by a knob causing the rays to be reflected upwards for the projection of objects in a horizontal plane silvered prism which can be used at "C," or as an erecting prism in mount "D," limelight

burner or arc lamp, slide carrier, complete in travelling case, with reversible adjustable stage for supporting apparatus.

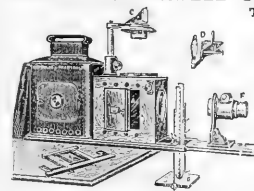

PRICE ON APPLICATION.

CATALOGUES (Post free).

Optical Lanterns and Accessory Apparatus. Chemical Apparatus and Chemicals, etc. etc. (new editions)

14 COMMERCIAL STREET, LEEDS.

## BAIRD & TATLOCK (LONDON) LTD.

SCIENTIFIC INSTRUMENT MANUFACTURERS  
and LABORATORY FURNISHERS.

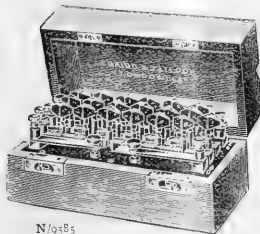

N/9585  
RESISTANCE BOX

Physical  
Apparatus  
for  
Schools  
and  
Colleges.

14-15 CROSS STREET HATTON GARDEN LONDON E.C.1

## HIGH RANGE THERMOMETERS

Of Guaranteed Accuracy.

### NATIONAL PHYSICAL LABORATORY

certificate of N. & Z. Thermometer No. D 10520.

Reading.	Correction.
212° F.	0° F.
300	0
400	0
500	+1
600	+1
700	0
805	0

Above is a copy of certificate of a Thermometer recently verified.

**NEGRETTI & ZAMBRA**  
38, HOLBORN VIADUCT E.C.1.  
LONDON.

## IMPERIAL COLLEGE OF SCIENCE AND TECHNOLOGY.

SOUTH KENSINGTON, S.W.7.

### DEPARTMENT OF OPTICAL ENGINEERING AND APPLIED OPTICS.

The Following Courses of Weekly Lectures will commence during the Autumn Session, 1922.

1. **GENERAL OPTICS (ELEMENTARY).** Professor Cheshire. Commencing Wednesday, October 4, at 4 P.M.
2. **ADVANCED OPTICS.** Professor Cheshire and Dr. Martin. Commencing Monday, October 9, at 12 noon.
3. **OPTICAL DESIGNING AND COMPUTING.** Professor A. E. Conrady. Commencing Tuesday, October 3, at 10 A.M.
4. **WORKSHOP AND TESTING ROOM METHODS.** Professor A. E. Conrady. Commencing Wednesday, October 4, at 2 P.M.
5. **ADVANCED DESIGNING AND COMPUTING.** Professor A. E. Conrady. Commencing Wednesday, October 4, at 10 A.M.
6. **CONSTRUCTION, THEORY AND USE OF OPTICAL MEASURING INSTRUMENTS.** Dr. Martin. Commencing Friday, October 6, at 12 noon.
7. **MECHANICAL DESIGN OF INSTRUMENTS.** Professor Pollard. Commencing Tuesday, October 3, at 12 noon.
8. **ELEMENTARY ELASTICITY AND STRENGTH OF MATERIALS.** Professor Pollard. Commencing Friday, October 6, at 2 P.M.
9. **MACHINE DRAWING.** Professor Pollard. Commencing Friday, October 6, at 3 P.M.

The following Special Courses of Lectures will be given—

1. **POLARISED LIGHT AND POLARISATION APPARATUS.** A Course of six weekly lectures, beginning on Tuesday, October 10, at 4 P.M., will be given by Professor Cheshire. The course will be repeated during the Summer Term on Mondays at 6.30 P.M., commencing April 30, 1923.
2. **MICROSCOPES AND MICROSCOPIC VISION.** A Course of ten weekly lectures, commencing early in October, exact time to be arranged, will be given by Professor A. E. Conrady. These lectures are intended specially for users of the microscope, and will be, as far as possible, non-mathematical.
3. **THE MECHANICAL DESIGN OF THE COMMON MICROSCOPE.** A Course of six weekly lectures will be given by Professor Pollard on Thursdays at 5 P.M., commencing January 18, 1923.
4. **COLOR AND ITS MEASUREMENT.** A Course of ten weekly experimental lectures, commencing on Tuesday, January 16, 1923, will be given by Dr. L. C. Martin.

For further particulars and for admission tickets apply to the REGISTRAR at the above address.

The Director is open to receive applications from students and others desirous of carrying out research work in the Laboratories.

### ENGINEERING AND TECHNICAL OPTICS.

## NORTHAMPTON POLYTECHNIC INSTITUTE,

ST. JOHN STREET, LONDON, E.C.1.

### ENGINEERING DAY COLLEGE.

Full-time Day Courses in the Theory and Practice of Civil, Mechanical, and Electrical Engineering. The Courses in Civil and Mechanical Engineering include specialisation in Automobile and AERONAUTICAL Engineering, and those in Electrical Engineering include specialisation in RADIO-TELEGRAPHY.

A SPECIAL ENTRANCE EXAMINATION is held at the end of September before the commencement of each session. The Courses include periods spent in commercial work-shops and extend over four years. They also prepare for the Degree of B.Sc. in Engineering at the University of London. Fees £18 or £13 per annum.

THREE ENTRANCE SCHOLARSHIPS of the value of £62 each for the complete course will be offered for competition at the annual entrance examination in September.

### OPTICAL ENGINEERING AND TECHNICAL OPTICS.

Full- and Part-Time Courses in this important department of Applied Science are given in specially equipped laboratories and lecture rooms. The annual entrance examination is held at the end of September.

### EVENING TECHNICAL COURSES

in all branches of Mechanical and Electrical Engineering commence on Monday, September 25, 1922.

The Laboratories, both Mechanical and Electrical, are well equipped with modern apparatus which, on the Mechanical side, provides for specialisation in Automobile and Aeronautical Engineering, and, on the Electrical side, for specialisation in Alternate and Continuous Current Work, in Radio-Telegraphy and Telephony, and in Electrical Testing.

More complete particulars, together with conditions of entrance, etc., and all information respecting the work of the Institute can be obtained at the Institute or on application to

R. MULLINEUX WALMSLEY, D.Sc., Principal.

## AUTHORS' TYPIST.—4th year Chemical

student undertakes typing of scientific papers, authors' MSS., etc., in French and German. Box 10, c/o NATURE Office.

## CHELSEA POLYTECHNIC,

CHELSEA, S.W.3.

Session begins September 25, 1922.

Day and Evening Courses in Science under Recognised Teachers of London University.

- I. **INDUSTRIAL CHEMISTRY DEPARTMENT.**  
Technical Courses in Analytical and Manufacturing Chemistry, Pharmacy, Food and Drugs, A.I.C. Courses, Metallurgy, Assaying, Foundry Work, Research.
- II. **INDUSTRIAL PHYSICS DEPARTMENT.**  
Practical work in General Physics, Applications to Industries, Metrology, Calorimetry, Illumination, Acoustics, Electrical Measurement, Research.
- III. **BIOLOGICAL AND GEOLOGICAL DEPARTMENT.**  
Courses for B.Sc., etc., in Botany, Geology, Mineralogy, Zoology, Special Courses in Bio-chemistry, Bio-physics, Bacteriology, Physiology, Hygiene, Entomology, Plant Pathology. Course for Tropical Planters, Research.

SIDNEY SKINNER, M.A.,  
Principal.

Telephone: Kensington 899.

## BIRKBECK COLLEGE.

(UNIVERSITY OF LONDON.)

Principal—GEORGE SENTER, D.Sc., Ph.D., F.I.C.

EVENING COURSES for the Degrees of the University of London in the Faculty of Science and for the Geography Diploma.

Facilities are also provided during both day and evening for Post-Graduate and Research Work.

Calendar, 1s.; by post, 1s. 5d. Prospectus free.

For full particulars, apply to the SECRETARY, Birkbeck College, Fetter Lane, E.C.4.

## BOROUGH POLYTECHNIC INSTITUTE.

BOROUGH ROAD, S.E.1.

### CHEMISTRY DEPARTMENT.

Under the direction of C. DORÉ, M.A., D.Sc., F.I.C.

The Classes, Elementary and Advanced Inorganic and Organic Chemistry re-open September 25, 1922.

The following special courses in Applied Chemistry have been arranged:

THE CHEMISTRY AND TECHNOLOGY OF THE ESSENTIAL OILS.  
Lectures and Practical Work—Fridays, 6.30 P.M. C. T. Bennett, B.Sc., F.I.C. Commencing October 6, 1922.

THE CHEMISTRY AND MANUFACTURE OF FOODSTUFFS.

Lectures—Mondays, 7 P.M. A. E. Parkes, F.I.C. Commencing October 2, 1922.

CHEMISTRY APPLIED TO THE LAUNDRY INDUSTRY.

Lectures and Practical Work—Tuesdays and Wednesdays, 2.45 P.M. Dr. C. Doré.

Attention is also directed to the facilities available for special work in Electrochemistry and Cellulose Chemistry.

For further particulars apply to the PRINCIPAL.

## THE UNIVERSITY OF LEEDS.

### DEPARTMENT OF TEXTILE INDUSTRIES.

### COURSES IN TEXTILE INDUSTRIES FOR GRADUATE STUDENTS.

October 1922 to June 1924.

Lecture and Demonstration Courses covering from the Raw Wool to the Finished Fabric. Graduate students may claim exemption from a third year's work and thus qualify under this Course for the University Diploma. Further information may be obtained from the REGISTRAR, The University, Leeds.

## TO SCIENTISTS, RESEARCH STUDENTS, AND SCHOLARS.

THE INTERNATIONAL BIBLIOGRAPHICAL SERVICE BUREAU supplies complete Continental and American bibliographies on any scientific, literary, or medical subject. Chemical work a speciality. Extracts made. Headquarters: Vienna. English representative: "ALEXANDRIAN," 1A Longbridge Road, Earl's Court, S.W.5.





SATURDAY, SEPTEMBER 23, 1922.

## CONTENTS.

	PAGE
The Supply of Petroleum Products. By H. B. M.	401
The Ways of Insects . . . . .	402
Chemistry of the Plant Cell . . . . .	403
Scientific Management of Farming . . . . .	404
An Ideal Text-book of Physics. By N. R. C.	405
Science Primers. By C. L. Bryant . . . . .	406
Atmospheric Electricity. By G. C. S.	406
Forest Policy and Management . . . . .	407
Thoughts on Scientific Advance. By W. M. B.	409
Our Bookshelf . . . . .	409
Letters to the Editor :—	
The Primitive Crust of the Earth.—John Parkinson	413
Action of Cutting Tools.—H. S. Rowell . . . . .	413
The Smoke of Cities.—Prof. A. E. Boycott, F.R.S., and Prof. J. B. Cohen, F.R.S. . . . .	413
Waterspouts. (Illustrated).—Dr. G. D. Hale Carpenter and D. Brunt . . . . .	414
Periodic Structure of Atoms and Elements.—H. Newman Allen . . . . .	415
Transmission of Sound of Explosions.—Sir Napier Shaw, F.R.S. . . . .	415
Research and Razors.—Prof. J. R. Partington . . . . .	415
Human Geography: First Principles and some Applications. By Marion I. Newbigin, D.Sc.	416
Educational and School Science. By Sir Richard Gregory . . . . .	420
The Royal Botanic Gardens, Kew. (Illustrated)	423
Obituary :—	
Dr. R. H. Codrington . . . . .	425
Current Topics and Events . . . . .	426
Our Astronomical Column . . . . .	428
Research Items . . . . .	429
Potato Trials at Ormskirk . . . . .	431
International Reunion of Chemists at Utrecht. By F. G. D. . . . .	431
Summary of the Theory of Relativity. By Prof. H. T. H. Piaggio . . . . .	432
Kitchen Ranges. By J. B. C. . . . .	434
University and Educational Intelligence . . . . .	435
Calendar of Industrial Pioneers . . . . .	436
Societies and Academies . . . . .	436
Official Publications Received . . . . .	436

Editorial and Publishing Offices :

MACMILLAN &amp; CO., LTD.,

ST. MARTIN'S STREET, LONDON, W.C.2.

Advertisements and business letters should be  
addressed to the Publishers.

Editorial communications to the Editor.

Telegraphic Address: PHUSIS, LONDON.  
Telephone Number: GERRARD 8830.

NO. 2760, VOL. 110]

## The Supply of Petroleum Products.

MR. SYDNEY BROOKS contributes to the *Fortnightly Review* for September 1 an article entitled "A British Oil Victory," from which the reader might at first infer the discovery of a large British oilfield or at least a sudden remarkable flow from the Hardstoft well in Derbyshire. Nothing quite so startling has happened, however; Mr. Brooks's "victory" is of a far less sensational character, being, in fact, the opening of the Anglo-Persian Oil Company's refinery at Llandarcy, Swansea. The author regards this event as the *pièce de résistance* of a series of British achievements in the "international war of industry," and mentions in the same breath the opening of the Manchester Ship Canal Oil-Dock, the discovery of oil in Papua, and the securing by a British Company of the oil rights of Macedonia.

It seems a pity to have to disillusion Mr. Brooks and his readers, but while one admires his natural pride in British commercial successes, and also the patriotic zeal with which he writes, there is in his article an optimism apparently born of an inadequate knowledge of the facts and a clouded sense of proportion. The Llandarcy refinery is admittedly a sound industrial proposition for this country, but one can scarcely recognise yet in its existence a really serious competitor with the Shell or Anglo-American Oil Companies' interests, as Mr. Brooks suggests. Even if the Anglo-Persian Oil Company agreed to distribute their petroleum products solely in the British Isles, this would only represent a relatively small percentage of the total annual consumption of such commodities in this country. The bulk of imports of petroleum products come from the United States and Mexico: they are controlled by the Dutch and American organisations referred to and together constitute more than twenty-five times the amount of such products obtained from Persia, based on recent statistics of production and importation.

There is always the possibility—indeed, the probability—that the Anglo-Persian Oil Company's interests will expand considerably in the next few years, but a refinery, however large and well-equipped, is dependent on an abundant supply of crude oil, and this must come to us from overseas. So long as the United States and Mexico together produce more than 85 per cent of the world's supply of crude petroleum, so long shall we be dependent on those countries and their representatives for the bulk of our supplies of petroleum products.

The construction of the Llandarcy refinery is indeed an industrial event of no mean importance, but at least let us preserve a clear perspective in the matter. The

Manchester Ship Canal Oil-Dock should be hailed rather as an engineering feat than an "oil victory"; without plenty of imported oil the dock ceases to exist as such. The strike of oil in Papua is not surprising; both in British and former German territory oil occurrences have long been known; geological surveys have been made and the oil sampled, but the technical difficulties, an appalling climate and the native labour troubles involved, have retarded development, even if oil exists in commercial quantity—yet a moot point. Then the Macedonian concessions are, geologically speaking, even more doubtful than Papua as regards oil potentialities: their securance may have been a political or commercial *coup*, but as an incident in the "British Oil Victory," it was neither heroic nor decisive.

We suggest to Mr. Brooks that in the general appreciation of the above facts lies the reason of apparent public indifference to the erection of the Llandarcy refinery; the matter was neither ignored nor its significance missed, as he complains; it is simply that to the average man this and kindred propositions appeal as ordinary extensions to business, and where oil is concerned especially, judgment by results rather than hasty optimism at the beginning is the safer policy.

H. B. M.

### The Ways of Insects.

*The Psychic Life of Insects.* By Prof. E. L. Bouvier. Translated by Dr. L. O. Howard. Pp. xvii+377. (London: T. Fisher Unwin, Ltd., 1922.) 8s. 6d. net.

THIS is, we think, the most reasonable book that has been written on insect behaviour as a whole. It is scholarly and critical; it avoids extremes; and it leaves open questions open. There is, as every one recognises, an inclined plane of insect behaviour. On the lowest level there are tropistic activities (the translator's term "tropic" will not do), when the insect makes towards or away from the light, against the stream or the wind, towards or away from an odour, and so on. In everyday life these tropisms count for much. They are obligatory constitutional automatisms; they are induced by asymmetry of stimulus which provokes asymmetry of muscular activity; and this automatically restores physiological equilibrium. Interesting situations arise when one tropism (*e.g.* in relation to light) influences or counteracts another (*e.g.* in relation to gravity); and it is also noteworthy that a tropism may change its character with the age or physiological state of the organism.

Then we have to recognise internal rhythms which are enregistered in the insect's constitution and imply

a certain organic memory. Very suggestive is Roubaud's case of the African "house-worms" (maggots of *Anthrenomyia luteola*) which burrow in the earthen floor of the hut during the day, but come up at night to gorge themselves on the blood of the prostrate sleepers. For Roubaud has proved that these larvæ experimentally treated can be induced to remain awake during the day. The rhythm is constitutional, but its punctuation is environmental.

Bouvier passes to the phenomena of "differential sensitiveness"—a term which never strikes us as very luminous. When a bed-bug, which naturally seeks darkness, is suddenly illumined, its typical behaviour is to turn through 180 degrees and proceed in the opposite direction. Insects avoid situations or postures which are contradictory to the exercise of their normal tropisms; but their behaviour is automatic, not voluntary. Moreover, the reversal of the movement in relation to a particular stimulus, say light, may be induced by a sudden change in some other stimulation, *e.g.* by a gust of wind or a warm breath. The familiar phenomena of "catalepsy" or "feigning death" in insects are regarded as exaggerations of "differential sensitiveness," and the author is very sceptical as to utilitarian interpretations.

So far there is no appreciable psychical note. That is not struck till we find the insect selecting one reaction rather than another, profiting by experience in a simple way, and showing individual as contrasted with organic memory. Some very interesting examples are given of an individual change of habit in novel circumstances. The intelligent adjustment of habits has played an important part in the evolution of instinctive behaviour, for insects have "the power very quickly to transform acts which are intelligent at first into automatic acts."

Bouvier's position in regard to instinctive behaviour is eclectic. There is no special faculty of "instinct," and the various forms of instinctive behaviour are not all on the same level nor of the same origin; some may have arisen as germinal mutations (which will be afterwards tested in everyday life), while others may have arisen in the course of intelligent apprenticeship. "In an intelligent way, new habits are established, which by heredity are added to the patrimony of instinct, modifying it and forming one of the essential elements of its evolution." "It is probable that all the higher instincts had originally this intellectual quality." And yet Bouvier agrees with Bergson that instinctive behaviour is on a different tack from intelligent behaviour; they help one another; they are both "opposites and complements."

It is likely enough that Bouvier is right in believing that instinctive behaviour is manifold, and that it may be established as an innate capacity in more than one

way. It is too soon to expect clear-cut conclusions in regard to these questions. But many will agree with the author in regard to the following three points. (1) There is in instinctive behaviour a psychical awareness as well as a physiological concatenation. "One can hardly see in insects simple reflex machines, for they know how to bend to circumstances, to acquire new habits, to learn and to retain, to show discernment. They are, one can say, somnambulists whose minds awoken and give proof of intellect when there is need for it. This takes us a long distance from the mechanism of which Bethe has made himself a protagonist." (2) Whether a capacity for novel instinctive behaviour originated from a sudden mutation or as the outcome of a more or less slow modification of habit, there must always be a period of individual apprenticeship, when the new card is played, or when the new adjustment is tested for what it is worth. (3) The climax of instinctive behaviour among arthropods is correlated with their characteristic organisation—a non-living armature of chitin with the musculature inside, not outside, and a considerable number of specialised appendages, which must be used in one way and in no other. "The appendages of Arthropods are nearly unchangeable in the individual and are narrowly adapted to certain purposes; they are the tools for instinctive work, thus differing from the less specialised but more supple limbs that serve as implements to the vertebrates, at least to the higher vertebrates." The contrast between a bee's specialised proboscis and a man's generalised hand is diagrammatic. So from the beginning, as Bergson also suggested, insects "were bound to use these organic tools, and they made the best use of them. Their main psychical task was to grave upon their memory and to repeat instinctively the acts to which these organs were fitted."

The fundamental part of Bouvier's masterly book is devoted to the analysis of the inclined plane of insect behaviour. He goes on to special problems such as the relation of insects to flowers, the faculty of orientation, the social life of insects, and the division of labour in nest-making Hymenoptera. Apart from a few slips, the translation, which cannot have been easy, is an effective piece of work.

### Chemistry of the Plant Cell.

*Chemie der Pflanzenzelle.* By Prof. Dr. Victor Grafe. Pp. viii + 421. (Berlin: Gebrüder Borntraeger, 1922.) 105 marks.

THE title of this book raises immediately the interesting question as to whether the chemistry of the plant cell can yet be made the subject of a text-

book. A perusal of this book leaves no doubt that such a work has still to be written. There are many interesting pages, but the book is in no sense an introduction to the special chemical metabolism proceeding within the plant cell.

The author treats his subject mainly from the point of view of physical chemistry, and the reader must, if the book is to be read with profit, be very thoroughly grounded in organic chemistry and bio-chemistry. Thus an interesting section on the cell wall, and a final subsection dealing with the chemistry of photosynthesis, are not accompanied by any discussion of the chemistry of the carbohydrates. Again, in a section of some 150 pages under the general title of protoplasm, ten pages only are assigned to the chemistry of lipoids (fats, phosphatides, sterols, etc.), proteins and nucleo-proteins; the same section closes with a subsection of some thirty pages, devoted to the pigments of the plant, which deal mainly with the recent researches of Willstätter upon the leaf pigments and the anthocyanins.

Lack of proportion is manifest throughout the book, and is accompanied by a lack of arrangement which leads to much tedious repetition. The main topics, diffusion, osmosis, plasma permeability, colloids, and adsorption, with which the book opens, recur again and again throughout its pages. Thus a later subsection headed plasma structure, in the section upon protoplasm, consists mainly of a rediscussion of the phenomena of plasmolysis and permeability. Undoubtedly these topics are of primary importance in a work upon plant physiology, but it is doubtful whether their significance in this field will be better apprehended as a result of the study of this book. The discussion of the physical chemistry of these complex phenomena is far too brief and inadequate to form a sound critical basis for their subsequent application to the still more complex problems of the living cell.

To cite specific cases: the first examples of adsorption phenomena dealt with, freely assume the specific adsorption of one ion from the solution of an electrolyte with consequent change in the reaction of the solution. The work of Baumann and Gully, and of Wieler, is cited in this connexion, and only upon a later recurrence of the topic is Sven Oden referred to in a footnote. Reference to Sven Oden's papers will show how unsound is the experimental basis for this assumption of specific ionic adsorption, while recent discussions by Bancroft ("Applied Colloid Chemistry," 1921) and E. A. Fisher ("Physico-Chemical Problems relating to the Soil," Faraday Society, 1922) show how inadequate are discussions of adsorption phenomena, based, as this one is, upon the application of Gibb's theorem

without further reference to the chemical questions involved.

Again, a brief discussion of the Liesegang rings obtained when silver nitrate diffuses into gelatin containing potassium bichromate (p. 43), is made the starting-point for many suggestions as to the significance of these phenomena in explaining stratification in structural features of the cell and even of tissues. In view of our lack of information as to these diffusion phenomena, little significance can attach at present to the analogous appearances in cell structures referred to by the author.

The physical properties of protein sols and gels are discussed without reference to the reaction of the solution or the iso-electric point of the protein, the fundamental papers published by Jacques Loeb being ignored. Swelling and imbibition remain, therefore, very incompletely treated, and the interesting American work upon the importance of pentosans in the retention of water by plant mucilages is also neglected. The author refers, however, in his preface to the continued post-war difficulty in obtaining access to foreign literature, and doubtless these sections will undergo modification in a later edition.

The subsection upon enzyme action shows a similar lack of arrangement. It is to be hoped that the author's endorsement of Euler's suggestion that when enzymes are active as catalysts during synthesis they should be denoted by the suffix "*ese*," will not lead to an extension of the practice. His discussion of enzymes in relation to metabolic synthesis is unsatisfactory, but it at least makes clear how little reason there is for such a practice. Without a clear discussion of modern views of the stereo-chemistry of the hexoses, the discussion of the catalytic action of maltase and emulsin during synthesis is necessarily difficult, but it is curious to find no mention of the experiments of Bourquelot and Bridel, which had reached an interesting stage even in pre-war days. An interesting discussion of the action of hormones in relation to stimulus and response appears in this subsection upon enzymes. The subject reappears in a later section under the heading of response to stimulus, and here reference is made to the work of Paal, Ricca, and others, the absence of which in the earlier discussion had aroused surprise.

The attempt made to base the phenomena of stimulus and response upon physico-chemical phenomena provides some of the most interesting reading of the book, but it would appear hopeless to expect success in such an effort when the subject of the quantitative study of growth rate is compressed into less than two pages at the end of this section.

### Scientific Management of Farming.

- (1) *Farm Management: A Text-book for Student, Investigator, and Investor.* By Prof. R. L. Adams. (Agricultural and Biological Publications.) Pp. xx+671. (New York and London: McGraw-Hill Book Co., Inc., 1921.) 20s.
- (2) *Organised Produce Markets.* By Prof. John George Smith. Pp. ix+238. (London: Longmans, Green and Co., 1922.) 12s. 6d. net.
- (3) *Agricultural Co-operation in England and Wales.* By W. H. Warman. Pp. xi+204. (London: Williams and Norgate, 1922.) 5s. net.
- (4) *Rural Organization.* By Prof. W. Burr. Pp. xiv+250. (New York: The Macmillan Co.; London: Macmillan and Co., Ltd., 1921.) 12s. net.

THE volumes before us emphasise the fact that farming involves two distinct kinds of operation, the production of crops and animals, and the marketing of the resulting commodities. Scientific investigators have in the past confined themselves almost exclusively to production, this being the side that involves the soil, the growing plant and the living animal, and with these almost all the sciences at present studied; it is quite evident, however, that there is a wide field for the economist in the marketing problems that will amply repay study.

(1) Prof. R. L. Adams deals exclusively with American conditions; his book is of a type that is not produced in this country, the old *Fream* in the past and some of the Oxford publications in the present being our nearest approach to it. It covers the whole range of the farm activities, largely from the economic side, but with constant references to modern improvements in production and the scientific principles on which they are based.

A great advantage of the book is the generous provision of tables of data showing crop yields, costs of production, effects of various factors on costs, on income, etc., with references to the original sources which will be at least equally appreciated. It is these data and references which give the book a special value to the teacher in this country, for he is thus enabled to ascertain how the values have been arrived at and how far they can help him in his work.

(2) Prof. J. G. Smith, of the Faculty of Commerce in the University of Birmingham, sets out in his book the general characteristics of organised markets and the broad principles involved in marketing operations. Considerable space is devoted to wheat and large-scale buying operations are discussed in detail. The volume is of interest as showing the extraordinary complexity of the processes whereby wheat is transferred from the Canadian farm to the English consumer.

(3) Major Warman deals more narrowly with the agriculturist and is concerned with an account of agricultural co-operation in England and Wales. He is convinced that co-operation is essential to the success of agriculture, and he is able to show that it is beginning to take hold on the rural community. Examples are given of farming societies, egg societies, dairy societies, etc., which are doing good work and have an undoubted future: we should, however, like to have seen some tables showing the amounts of produce handled, the financial turnover, etc. It may be the amounts are not large, but it is desirable that the data should be published.

(4) Prof. W. Burr discusses a wider problem, the organisation of the whole rural community in contradistinction to the urban population. It is widely recognised by American writers that the urban and rural communities are distinct, having different needs and requiring different methods of organisation. In this country the rural organisation has grown up through long ages and the urban population is the new problem: in America, however, the rural community is also new, and experts are studying closely the method in which it has developed, and feeling their way to some new organisation. The book is written for students, and it includes lists of questions and "research problems," which space, however, might usefully have been devoted to references to help those who wish to pursue the study of this interesting subject.

### An Ideal Text-book of Physics.

*Cours de physique générale à l'usage des candidats au certificat de Physique générale, au diplôme d'Ingénieur-Électricien et à l'Agrégation des Sciences physiques.*  
Par Prof. H. Ollivier. Tome Second: Thermodynamique et Étude de l'Énergie rayonnante. Deuxième édition, entièrement refondue. Pp. 415. (Paris: J. Hermann, 1922.) 28 francs net.

FEW examination candidates are likely to base their studies on a book in a foreign language adapted to foreign courses; and it is therefore unnecessary to consider here the merits of this work for the purpose for which it is primarily intended. It will suffice to say that none but the ablest students could master it unaided. But as an exposition of the fundamental propositions of mathematical physics, from which those of us who have passed the examination stage may refresh our memories concerning what we once knew, or were officially credited with knowing, the volume exhausts our vocabulary of praise. There are no native works which profess to cover the same range, and few of any merit which cover part of it.

We usually rely on Winkelmann or Chwolson. The former is far more encyclopædic, the latter more experimental; for M. Ollivier gives very few references and only such experimental facts as are necessary to illustrate principles; but in conciseness, lucidity and accuracy they are not to be mentioned in the same breath with our author. Even in completeness he is sometimes superior, for he enters more fully than most authors into some interesting byways of physics, such as luminescence, photometry and astrophysics.

The treatment is at once original and conservative. The order of historical development is usually abandoned completely and the subject developed in the full light of our present knowledge. Consequently, the science is presented deductively rather than inductively, the most general principles being stated first and their most important logical consequences (which are of course really their basis) gradually worked out. Whether this reversal of the usual sequence is desirable in teaching may perhaps be questioned, but there is no doubt of its efficacy in summarisation. On the other hand, there are no signs of the modern tendency to seek principles so broad and far-reaching that in gaining generality they almost lose physical significance. Thus the Boltzmann conception of entropy as probability appears only towards the end of the exposition of thermodynamics and the Nernst theorem appears mainly in foot-notes. But there is nothing old-fashioned about the book; if the author does not always pay so much attention as some would wish to the latest work, the reason is clearly a deliberate judgment of value and not mere ignorance.

But M. Ollivier's supreme merit in our eyes is that he really does write about mathematical physics. He does not give us either a treatise on pure mathematics which neglects the distinction between experiments which can, and those which cannot, be carried out, or a mere collection of familiar formulæ with "proofs" which prove nothing but the author's incapacity for accurate thought. He actually tells us how important magnitudes are measured and what is implied by the fact of their measurement; he realises that to define a magnitude and to say how it is measured are one and the same thing. Yet he does not fall into the opposite vice and weary us with needless pedantry; many readers will probably appreciate his abandonment of the old inadequacies and inaccuracies only by finding that, for the first time, they truly understand.

However, it is needless to continue in this strain. The present reviewer is not acquainted with the first volume of M. Ollivier's work and must confess that he had never heard of the work until it came into his hands for review. Many others are probably in a similar state of ignorance. The best that he can wish

for the future of physics is that such a condition should become impossible, that "Ollivier" should become a household word and his treatise (if it is all equally good) be found in the library of every serious physicist.

N. R. C.

### Science Primers.

- (1) *First Course in General Science*. By Prof. Frederic Delos Barber and others. Pp. vii+607. (New York: Henry Holt and Co.; London: G. Bell and Sons, Ltd., 1916.) Price 9s. net.
- (2) *The Science of Everyday Life*. By E. F. Van Buskirk and E. L. Smith. Pp. xvi+416. (London: Constable and Co., Ltd., n.d.) 7s.
- (3) *A First Book of General Science: An Introduction to the Scientific Study of Animal and Plant Life*. By A. T. Simmons and A. J. V. Gale. (First Books of Science.) Pp. viii+145. (London: Macmillan and Co., Ltd., 1921.) 2s. 6d.

THESE three books offer a good contrast between British and American tendencies as regards general science in education. In the two countries, the movements in this direction have been going on independently. In both cases, they sprung from efforts made, in the 'nineties, in two or three schools, to take a bird's-eye rather than a toad's-eye view of science—to use the words of the Principal of one of the Illinois schools. In both cases, again, the growth of the movement began to be rapid about ten years ago.

With characteristic thoroughness, the Americans are fast reducing their methods to a system. In this country we are still in the middle which seems to be our natural habit of growth. Now that examining bodies are issuing schedules of work to be done in this connexion, teachers may be forced to set their houses in order. Then, perhaps, the hardly-won freedom from traditional restraint may again be lost. It is to be hoped that the outcome will be more satisfactory in the way of awakening general interest in things scientific than the work of the last century proved to be.

(1) But to return to the contrast: in America, the teaching of general science is itself being developed into a science; in Britain, it remains an art. If in one case it might be more scientific, in the other it might well be more artistic. The book which Prof. Barber and his collaborators have written is among the best of its kind—and many good ones have been published across the water. It may even be objected that it is too complete. In a single column of the index, the following words occur: machines, malaria, maltose, meat, metabolism, monsoons, motors, mucor, mumps. Experience shows that anything like a proper assimila-

tion of such mixed dishes occupies three or four years. Are the pupils to have the same text-book during all that time? Will not they tire of the style, the print, the binding? There is a certain value in change, if only for the incentive to make a new and better start. In such things, perhaps, the art of teaching lies.

(2) "The Science of Everyday Life" depressed us. It seemed such a good book spoiled—spoiled by the very riot of the science of teaching. Here we have done with chapters: the book is divided, instead, into two parts, five units, and eighteen projects. Every one of the latter is subdivided monotonously into introduction, problems, topics, and individual projects. A project, by the way, has been defined as a whole-hearted, purposeful activity proceeding in a social environment. Pupils may be expected to ask questions about their activities; but lest they should omit to do so, the authors give lists of questions which they ought to ask. When they have completed a project, the whole-hearted, purposeful, and active seekers after knowledge must feel that there is nothing more that they ought to know, can know, or want to know about it. Frankly, despite the authors' introduction, we can scarcely think of a surer way of killing initiative. Yet the subject-matter of the book is good, and teachers who are rather short of ideas might do well to study it. We ourselves found the diagram showing the various cuts in a side of beef instructive!

(3) "General Science," by Simmons and Gale, provides a refreshing contrast. Here the authors set out with a single aim: to make their young readers acquainted with the manner in which plants and animals live, and to describe some of the physical and chemical processes which are involved. A small book, the general purpose can be grasped by boys and girls; and they may hope to master the contents within a reasonable time. It is written as a man might write for men—children hate to feel that they are being written down to. The science of teaching does not obtrude itself upon the pages; which is not the same as to say that it is absent. That is where the art of teaching plays its part. The authors have compiled a book which is both sound and eminently readable. It is sure to find a wide acceptance.

C. L. BRYANT.

### Atmospheric Electricity.

*Électricité atmosphérique*. Par B. Chauveau. Premier Fascicule: Introduction historique. Pp. xi+90. (Paris: G. Doin, 1922.) 10 francs.

M. CHAUVEAU has set out to write a work on atmospheric electricity—a very laudable undertaking, for, as he says in his preface, there is no

such work in the French or English languages, while there are only two in German. He proposes a work in three parts: (i.) historical introduction, (ii.) the electrical field of the atmosphere, and (iii.) ions, ionisation, and radio-activity. Part i. has now appeared, and if it may be taken as a fair sample of the whole, we may expect a very welcome addition to the literature of the subject.

M. Chauveau commences his history with the celebrated letter from Franklin to Collinson (dated 1750) in which the great American philosopher suggests a method for testing the hypothesis, then fifteen years old, that thunder and lightning are electrical phenomena. From this commencement the following stand out as the milestones along the path of progress:

(1) The proof that thunder and lightning are electrical phenomena: Dalibard, May 1752; Franklin, June 1752.

(2) The discovery of the electrification of the atmosphere with clear skies: Lemonnier, Sept.-Oct. 1752.

(3) The discovery of the daily variation: Beccaria, 1753-1775.

(4) The discovery of the annual variation: De Saussure, 1785.

(5) W. Thomson's (Lord Kelvin) improvements in instruments and methods, and the introduction of the idea of electrical potential gradient: 1856-1874.

(6) The discovery of the conductivity of air: Linss, 1887; Elster and Geitel and C. T. R. Wilson, 1899.

(7) The discovery of "atmospheric radio-activity": Elster and Geitel, 1902.

(8) The discovery of a very penetrating radiation in the upper atmosphere: Hess and Kolhörster, 1911-1914.

In telling the story of the progress from milestone to milestone, M. Chauveau has related the history of the development of instruments and methods and described the many attempts to find physical explanations of the phenomena observed. At first the observations were made with insulated conductors, generally pointed, from which sparks were drawn, but Lemonnier tested the electrical state of his "collector" by noting whether it attracted powder, and by this relatively delicate method he first detected "fine weather electricity." Later rough electroscopes, fitted with pith balls or gold leaves, made quantitative measurements possible, and so led to the determination of the diurnal variation by Beccaria. With electroscopes it was possible to detect a change in the electrical state of an insulated conductor as it was raised and lowered in the atmosphere (induction effect), and De Saussure used this method with remarkable results in 1785. It was with the discovery of "the power of the flame" to charge a conductor

exposed to the atmosphere, which Volta made about 1780, that trustworthy methods became possible, but this discovery remained practically unused, and it was not until W. Thomson took up the study of atmospheric electricity some seventy years later that measurements were put on a sound physical basis.

Hypotheses and theories to explain the observations are innumerable: Volta's theory of the separation of electricity on evaporation; Peltier's theory of a permanent negative charge on the earth's surface, partially dissipated into the atmosphere by evaporating water and returned on condensation; Sohneke's theory of friction between water and ice; and Brillouin's theory of the electrical separation caused by ultra-violet light falling on the ice crystals of cirrus clouds; these are the most important. But every theory to explain the maintenance of the earth's electrical field has failed, and we appear to-day to be further from an explanation of this fundamental phenomena than we have been at any previous time. Even now we do not know whether the earth with its atmosphere is electrically neutral or whether there is a residual charge, and at the present moment there is not a single theory seriously maintained to explain the constant interchange of electricity between the earth's surface and the lower atmosphere.

G. C. S.

### Forest Policy and Management.

(1) *Schlich's Manual of Forestry*. Vol. 1: *Forest Policy in the British Empire*. By Sir William Schlich. Fourth edition, revised and enlarged. Pp. xi+342. (London: Bradbury, Agnew and Co., Ltd., 1922.) 15s. net.

(2) *The Practice of Silviculture: With Particular Reference to its Application in the United States*. By Prof. R. C. Hawley. Pp. xi+352. (New York: John Wiley and Sons, Inc.; London: Chapman and Hall, Ltd., 1921.) 22s. net.

(3) *Forest Mensuration*. By Prof. H. H. Chapman. Pp. xxii+553. (New York: J. Wiley and Sons, Inc.; London: Chapman and Hall, Ltd., 1921.) 30s. net.

(4) *A Short Manual of Forest Management*. By H. Jackson. Pp. x+70. (Cambridge: At the University Press, 1921.) 7s. net.

SIR W. SCHLICH has crowned a long life of devotion to the science and art of forestry by the publication of what is practically a new work, although it purports to be only a new edition of vol. 1 of his well-known Manual. (1) This volume is certainly the most valuable book on the economics and the history of British forestry that has yet appeared. It should

prove interesting to the statesman and the economist, as well as to the forester and the industrialist.

The first part treats of general principles. The utility of forests is considered directly, when concerned with actual products, such as timber, turpentine, tans, etc.; and indirectly, when it is a question of the influence of forests on climate, soil erosion, hygiene, aesthetics and ethics. The last three are more important than is generally believed; and Sir William pleads for the creation of woodlands near large towns, which will serve as recreation grounds for the people and at the same time produce timber finding a ready sale, so that the establishment of these city forests need not be a financial burthen. Glasgow, renowned for its municipal enterprise, is the first of our cities to acquire a forest area for the enjoyment of its inhabitants, the Ardgoil Estate.

After the subject of the State in relation to forests is discussed, the remainder of the book, some 300 pages, deals with the actual condition of forestry in the British Empire. The British Isles, India, Canada, Newfoundland, South Africa, New Zealand, and the Crown Colonies are treated separately. The natural history of the forests, their resources in timber, the modes of silviculture, government policy, education, etc., are all carefully described, sketch maps and statistical tables being added where required.

(2) Considering the vast amount of information on the practice of silviculture which is scattered in British and American forestry journals and official bulletins, it is remarkable how few formal text-books on the subject have been published in English. The present work by a Yale professor is therefore very welcome. It deals primarily with conditions in the United States; but as the principles of silviculture are the same everywhere, the book can be used by British students with scarcely any change or comment. It is a compilation, remarkably up-to-date, and rendering matter available for study which otherwise could be found only by long search in German and French books. The author's presentation of facts is clear, and well illustrated by suitable diagrams.

There is, however, one serious defect, the omission of the subject of reproduction of the forest by artificial means, the reader being referred for information on this point to "Seeding and Planting," a companion book by Prof. Toumey, also of Yale University. Artificial planting of trees is much more common with us than natural regeneration; and the necessity of using another book will be irksome to British students. Prof. Hawley's exposition of the methods of natural regeneration is excellent; but the best chapter in the book is one dealing with "thinning," a difficult subject. Another subject, also treated in a fresh and original

manner, is the disposal of the "slash" or rubbish which is left on the ground after felling operations. This is important, as on the removal of the "slash" depends in great measure the freedom of the forest from injury by fire, insects, and fungi. General measures of protection against these three agents of destruction, as well as damage caused by grazing, are treated in four short chapters.

An excellent feature of the book is an appendix of more than forty pages on terminology, which is really an alphabetical list with definitions of the terms used in the science and art of forestry. This glossary, which was drawn up in 1917 by the Society of American Foresters, will serve to stimulate accuracy of statement by foresters. German and French equivalents are given.

(3) Prof. Chapman's "Forest Mensuration" is the third text-book on forest mensuration which has appeared in English, and it is well designed to become the standard authority on the subject in the United States. The system of measuring timber in North America is totally different from ours. There, the contents of trees and logs are expressed in terms of the probable out-turn in sawn boards, according to a certain log-rule; hence the phrase "board feet." In the British Isles timber is measured as a raw material in terms of the real cubic volume. The American system introduces extraordinary complication into forest mensuration, some thirty log-rules being now in use in different parts of the country, no two rules giving the same result in board feet. A considerable part of the book is taken up with these log-rules and the principles underlying their construction—all of which is useless to the forester in Europe or India.

Nevertheless, a large part of the volume is of interest, for once log-rules are disposed of, the author is on common ground with his European fellow foresters, and gives a good account of recent developments of forest mensuration by Swedish and German writers. The accurate measurement of masses of standing trees is difficult, but is obligatory for purpose of valuation, and is of great use as a means of determining from time to time the increment of a growing wood. Upon a knowledge of the latter depends the fixing of the proper time for felling. Part III. deals with the laws of growth of stands of trees, and is by far the most interesting subject discussed, as the principles involved are the same in all countries where scientific forestry is practised. The preparation of yield tables and their application to predicting future yields are treated fully. The book will be useful in the reference library, but cannot be recommended as a handbook for British students, on account of its preoccupation with American practice.

(4) Forest management is little understood in the



British Isles, where owners of woods usually confine their attention to the practical work of planting, thinning, and felling trees, without having clear ideas of the financial problems involved. The objects of management are classified as being either physical or economic. The former apply to protection forests, maintained on mountain slopes to prevent erosion and mitigate disastrous floods, to forests on catchment areas that afford water supplies to towns, and to private woodlands on estates which are treated as amenity grounds for ornament and sport. An economic object of management applies to any forest worked for timber and other saleable products. Forests of this kind are commercial undertakings, and the scheme of management adopted here should be such as to render the woodlands a financial success, yielding the maximum soil rental and giving the highest net return on the capital involved. The principles underlying forest management are clearly explained in Mr. Jackson's little book, which can be recommended as an introduction to this important subject.

### Thoughts on Scientific Advance.

*Problems of Modern Science.* A Series of Lectures delivered at King's College (University of London). Edited by Prof. Arthur Dendy. Pp. 237. (London: G. G. Harrap and Co., Ltd., 1922.) 10s. 6d. net.

THE object of this series of lectures is stated to have been to "place before the general public the present position of some of the main branches of science and to point out the direction in which progress is being made or may be hoped for in the near future." The book will also be found useful by scientific workers who desire to know something of the advances made in regions other than their own. The names of the lecturers are a sufficient guarantee of the value of the matter presented. It is unfortunate that no index is provided, and, for this reason, perhaps the most useful function of a review is to give some indication of the contents of the book. But it is to be understood that the topics mentioned by no means exhaust the list.

Prof. Nicholson's lecture on mathematics shows that much more research work is possible in that science, and it gives a useful account of the quantum theory. In Prof. Dale's astronomical lecture, we find a summary of the present position of the nebular hypothesis. It is interesting to find that certain kinds of nebulae may reasonably be looked upon as bye-products of evolution. Prof. Richardson gives us a valuable general account of the latest views on the structure of atoms, and also further statements with regard to the quantum theory.

Prof. Smiles refers especially to the chemistry of plants.

Prof. Dendy's lecture is an interesting discussion on the various component sciences making up that of general biology. A remark on page 131 with reference to the widespread influence of physiological considerations may be noted—"It is perhaps unfortunate that our interest in ourselves as human beings has resulted in the concentration of attention upon the functions of the human body, almost to the exclusion of the lower animals, so that the development of this branch of Biology has been a very lop-sided growth." It is to be hoped that recent developments, especially at the Plymouth Marine Biological Station, will remedy this state of affairs.

Prof. Ruggles Gates deals with various botanical problems, more especially with those of genetics and mutations. Prof. Halliburton is mainly concerned with pointing out the importance of free fundamental research in physiological science and gives various examples where important practical application at a later date was quite unforeseen. Prof. Barclay-Smith devotes his lecture to a useful account of the formation of bone, which presents phenomena of much greater general interest than some would be inclined to suppose.

The book may be thoroughly recommended, and the price is not excessive in comparison with many scientific works at the present day.

W. M. B.

### Our Bookshelf.

*The Newcomen Society for the Study of the History of Engineering and Technology.* Transactions, Vol. 1, 1920-1921. Pp. 88 + 18 Plates. (London: The Newcomen Society, 1922.) 20s.

IN technology as well as in science the value of a knowledge of the history belonging to a given subject is gaining recognition. One result of the celebration at Birmingham of the centenary of James Watt in 1919 was the formation, by a few engineers interested in historical research, of the Newcomen Society, and the first volume of the society's Transactions has recently been issued. As indicated in its sub-title, the object of the society is to encourage the study of the history of engineering and technology, and it is, we believe, the first society formed for such a purpose. It takes its name from Thomas Newcomen (1663-1729), the Dartmouth blacksmith to whom we owe the atmospheric steam-engine. The honorary secretary and treasurer of the society is Mr. H. W. Dickinson, of the Science Museum, South Kensington.

Besides the papers read during the session 1920-21, the volume under notice contains the first presidential address, a list of members, the rules and constitution, and an account of the first summer meeting. Mr. Titley, in his address, after giving a brief sketch of the steps leading to the formation of the society, passes in review the subjects which come within its scope, points

to the various activities open to its members, and emphasises the use of history in everyday work.

The first paper given is entitled, "Introduction to the Literature of Historical Engineering to the year 1640," and to this is appended a valuable bibliography of books relating to early inventions. Then follow interesting papers on "The Rise and Fall of the Sussex Iron Industry," "The Mystery of Trevithick's London Locomotive," and "The Invention of Roller Drawing in Cotton-spinning," all of which are illustrated by plates. The Transactions, which are well printed, will appeal, we think, to the general reader as well as the expert.

*Espace, Temps et Gravitation: la théorie de la relativité généralisée dans ses grandes lignes.* Par Prof. A. S. Eddington. Ouvrage traduit de l'anglais. Par J. Rossignol. Pp. xii+262+iv+149. (Paris: J. Hermann, 1921.) 28 francs net.

In the introduction which has been written for this translation by Prof. P. Langevin we read: "Dès que m'est parvenu ce Livre où M. Eddington réussit à exposer de manière à la fois si simple, si vivante et si personnelle la merveilleuse transformation que le génie d'Einstein a introduite dans les conceptions les plus fondamentales de la Physique, j'ai pensé qu'une traduction en devait être faite pour permettre au public français de partager la joie que sa lecture m'avait fait éprouver.

"Une démarche immédiate m'apprit que l'initiative avait été prise quelques jours plus tôt par M. Jean Becquerel et que le travail était commencé dans les conditions les plus favorables, puisque je n'aurais pu proposer un meilleur choix que celui de M. Rossignol pour le traducteur, et que M. Eddington voulait bien s'assurer lui-même que les nuances, souvent délicates, de sa pensée seraient fidèlement rendues."

The French edition of Prof. Eddington's well-known book has thus appeared under ideal conditions, and it would appear presumptuous were one to express an opinion as to the merits of the translation. This edition is of greater length than the original English edition (see NATURE, vol. 106, p. 822, 1921), as it has been supplemented by a theoretical part in five sections as follows: I.—Elementary Principles; II.—The Theory of Tensors; III.—The Law of Gravitation; IV.—The Mechanics of Relativity; V.—Electricity. These sections are valuable additions to the original, and awaken regret that they were not included in the English edition. The translation will doubtless receive a warm welcome from our French colleagues.

*Monograph of the Lacertidæ.* By Dr. G. A. Boulenger. Volume ii. Pp. viii+451. (London: British Museum (Natural History), 1921.) 3s.

THE "Monograph of the Lacertidæ," by Dr. G. A. Boulenger, the first volume of which was published in 1920, is now completed by the issue of the second and concluding volume. In collecting the materials for this work Dr. Boulenger has not been content to rely entirely on the resources of the British Museum, but has travelled widely and far over all Europe and examined the collections of all the principal Natural History Museums. He has made a special point of searching for and examining for himself the type

specimens of as many species as possible. The result is a monograph based on the examination of an immense material including the greater part of the actual type specimens.

Two features of this catalogue deserve special mention. The present whereabouts of the type specimens, where known, are given, information of the greatest value to future workers, and a full list of the specimens in the collections of the British Museum gives at a glance the resources of that Institution and should be particularly useful to specialists abroad.

The monograph is at once the most complete and the most authoritative on the Lacertidæ that has yet appeared, and will for a long time remain the standard work on the subject. It is, we believe, the last piece of work done by Dr. Boulenger in his official capacity at the British Museum. It is a fitting climax to the long series of catalogues and monographs on fishes, amphibia, and reptiles which have marked his great services to science at the British Museum.

British Museum (Natural History) Economic Series, No. 13. *Mites Injurious to Domestic Animals (with an Appendix on the Acarine Disease of Hive Bees).* By Stanley Hirst. Pp. 107. (London: British Museum (Natural History), 1922.) 3s.

THIS profusely illustrated little book on the mites infesting domestic animals is the thirteenth of the series of pamphlets on economic entomology issued by the British Museum (Natural History). Like its predecessors, it is designed on strictly practical lines, and the subject-matter cannot fail to appeal to a wide circle of interested readers, from the systematic entomologist and experimental pathologist to the breeder and fancier, be it of horses, cattle, pigs, dogs, rabbits, fowls, or bees. A little more than half of the book is devoted to the important family Sarcoptidæ and the various species of mange for which members of this family are responsible. Useful hints on the treatment and management of infected stock are supplied, and wherever these parasites have been known to transfer their attentions to human beings, the fact is mentioned. Parasites of this order may prove to play an important part in the transmission of infectious disease, not only from animal to animal but from animal to man; and to the medical or veterinary entomologist searching for a possible transmitting agent of some obscure animal plague, the accurate descriptions and illustrations supplied in this book will be very helpful. An interesting feature is the appendix devoted to the description of "Isle of Wight" disease (Acarine disease of bees) and its causation by the mite *Acarapis woodi* which inhabits the tracheal tubes of infected bees.

*The Changing Year.* By Anthony Collett. Pp. viii+310. (London: Hodder and Stoughton, Ltd., n.d.) 15s. net.

MR. COLLETT has done well to collect his delightful Nature essays, originally contributed to the *Times*, and to publish them in this more permanent form. They are worthy of preservation, for Mr. Collett is a field naturalist of first rank. He has a keen and accurate eye for observation and an ear tuned to record the music of Nature which he hears around him, and he combines with these a gift of expressing what his

senses have appreciated in simple yet delightful language which cannot fail to awaken in his reader that intense enthusiasm and love for Nature which he himself undoubtedly feels.

In this book Mr. Collett guides us pleasantly through the year, pointing out the sign-posts which mark the progress of the weeks and months: the awakening of the spring, the arrival of the birds on spring migration, the intense bustle and activity of the early months of the year, the quieter and more matured beauty of summer, the renewed activity of autumn with its preparation for the winter, and the calm peace of the winter months with always the promise of spring and life.

The book is full of useful facts and details which only the true field naturalist can acquire and observe. We regret that there is no index by means of which ready reference to these first-hand observations can be made.

*Radio Receiving for Beginners.* By Rhey T. Snodgrass and Victor F. Camp. Pp. 99. (London: Macmillan and Co., Ltd., 1922.) 3s. 6d. net.

THIS is a work professedly intended for those with very limited knowledge of wireless matters, but the author, in his endeavour to avoid technicalities in the introductory portion, has rather missed the opportunity of presenting the elements of the subject in a sufficiently tangible form for the reader, if really unacquainted with the principles of wireless working, to pick up readily the full meaning of the excellent chapters which follow. In these, we are conducted progressively through crystal reception, plain valve reception, regenerative working, and single and double valve amplification. A good typical arrangement of connections is given in each case, but it is understood that many variations can prove equally satisfactory. All this part of the book is thoroughly practical, and its utility is not greatly interfered with by the fact that it refers to American conditions alone. The general hints and the chapter on aerial construction are full of useful points, and explanatory notes on some of the individual pieces of apparatus which make up the complete equipment are contained at the end. The author makes it amply clear that wireless reception requires care, skill, and practice to get really good results, and is a good deal more than buying a complete outfit and "listening in" with a telephone.

*Applied Calculus: An Introductory Text-book.* By F. F. P. Bisacre. Pp. xvi + 446. (London: Blackie and Son, Ltd., 1921.) 10s 6d. net.

THE adjective "applied" is used by Mr. Bisacre to imply "the treatment of practical problems being preceded by a fairly full discussion of the necessary theory." We thus get a competent elementary account of the differential and the integral calculus, followed by applications to curves, maxima and minima, electricity and magnetism, chemical dynamics and thermodynamics. The chapter on electricity and magnetism is too short, while that on thermodynamics is quite long. An attempt is made to clear up the mystery of limits, but the success would be more certain if the example used for the purpose were not the rather trivial one of finding the limiting value of

$x^2$  when  $x$  becomes equal to 10. It is doubtful whether "epsilonology" is at all in place in such a book, and the practical student will scarcely be impressed with its value in view of the author's treatment. The tables should have been more extensive; as they stand their usefulness is very limited.

Interesting features of the book are photographs and biographies of pioneers in the calculus and its applications. The mottoes at the heads of the chapters are often cleverly chosen, like "A snapper-up of unconsidered trifles" for the chapter on integration.

S. B.

*The Care of the Adolescent Girl: A Book for Teachers, Parents, and Guardians.* By Dr. Phyllis Blanchard. Pp. xxi + 201. (London: Kegan Paul and Co., Ltd., 1921.) 7s. 6d. net.

IN her foreword to this book, Dr. Phyllis Blanchard explains that its object is to help teachers, parents, and guardians to provide adolescents with definite information concerning their own nature and to point the way to a proper utilisation of their energies.

After introducing the views of various authorities, Dr. Blanchard considers the instincts of the adolescent girl and the resulting conflict and repressions, and later, the pathological results of these repressions. The most important chapter is that devoted to the sublimation of the sex factor into other activities.

It appears that the author considers the adolescent conflict as entirely sexual in nature; but its solution, which may be described as an adjustment to the perpetual mate, is not the only one in which the guardian and teacher must assist. The adjustment to society, the failure in which gives us the recluse, the crank, and the social rebel, is practically ignored. An adjustment to the conception of the infinite, failure in which leads to the conflict found in nearly all agnostics and materialists, is only dealt with as a method of sublimation of the sex factor; from this point of view the author evolves a Christianity which, as Dr. Scharlieb states in her preface, is scarcely to be recognised as Christianity by those who have been brought up in any of the orthodox schools.

*Hyperacoustics.* By John L. Dunk. Division II. Successive Tonality. Pp. xi + 160. (London: J. M. Dent and Sons, Ltd.; New York: E. P. Dutton and Co., 1921.) 5s. net.

THE first division of the author's work, "Simultaneous Tonality," was published in 1916 and was shortly afterwards reviewed in these columns (vol. 98, p. 306, December 21, 1916). At least one-third of the present volume is devoted to a "brief résumé" of the earlier book, and then the author passes on to the new aspect of his subject, "Successive Tonality." The method of treatment is similar to that adopted previously, and there is little to add to the notice of the first volume. The nomenclature is so complex that a glossary, occupying six pages of the text, is provided for the convenience of the reader. The author recognises the difficulty clearly: "The jargon of each particular science is a real obstacle, not only to the acquisition of knowledge, but to the sympathetic understanding by workers in parallel fields, who, occupied with their own formulæ, tend to be repelled

when confronted with the hieroglyphics of a sister science." The present reviewer is unable to agree that the "jargon" here employed is likely to promote clear thinking, and does not believe that it will ever form the basis of a common language among all who are interested in the subject.

*Handbook for Field Geologists.* By Dr. C. W. Hayes. Third edition, revised and enlarged by Sidney Paige. Pp. xi+166. (New York: J. Wiley and Sons, Inc.; London: Chapman and Hall, Ltd, 1921.) 13s. 6d. net.

DR. HAYES'S manual, well bound, with rounded corners and gilt edges, is clearly intended for the pocket or the haversack. It is based on the methods adopted by the United States Geological Survey, and covers a certain amount of simple topographic surveying for ascertaining correct positions. The diagrams to illustrate forms of outcrop are small, as is necessitated by the size of the page, and we may prefer the bolder treatment given to this subject in Dr. Elles's recently published "Study of Geological Maps." Some matters, such as the description of common minerals in Appendix I, with its old-fashioned chemical formulæ, might have been left to the text-books with which the surveyor must become acquainted before he goes into the field. The directions as to the collection of the remains of fossil vertebrates and the investigation of placer deposits will rouse feelings of envy among those whose work is confined to the British Isles. But is the work of a geologist ever so confined? For those who are true geologists because they travel, Mr. Paige has provided a compact and handy guide. It points out, at any rate, on what details attention should be fixed. G. A. J. C.

*The Psychology of Medicine.* By Dr. T. W. Mitchell. Pp. viii+187. (London: Methuen and Co., Ltd., 1921.) 6s. net.

THIS book is intended primarily for those who, without being students of medicine or psychology, wish to keep themselves abreast of modern thought in these subjects. The earlier chapters are devoted to a discussion of the various psychological theories, commencing with Janet's theory of dissociation and its connexion with hysteria and the hypnotic state, and then passing on to Freud's theory of repression. The rest of the book deals with the conception of the unconscious, with psycho-analysis, and with the classification, treatment, and prevention of neuroses. Psycho-analysis is described from three aspects, namely, as a method of investigation, as a doctrine of the content and process of the mind, and as a therapeutic method.

The clearness and impartiality with which Dr. Mitchell has considered conflicting views will be appreciated by the reader who requires only a general outline of modern psychology. A few notes are appended for guidance in selecting literature for further study of the subject.

*Graphical Analysis: A Text-book on Graphic Statics.* By W. S. Wolfe. Pp. xiv+374. (New York and London: McGraw-Hill Book Co., Inc., 1921.) 20s. net.

MR. WOLFE offers us a detailed study of the graphical methods as used in static problems, with applications to the investigation of various types of structures. He

first sets out the ordinary theory of force and funicular polygons. The graphical processes for finding centres of gravity, moments, and moments of inertia come next, and then bending moments and shearing stresses of beams. Frameworks follow, applied to all kinds of trusses, roofs, and arches. After a chapter on moving loads on bridges we get the study of masonry piers and masonry arches as well as of reinforced concrete. A chapter on design of beams and struts, and a chapter on miscellaneous problems, complete an exhaustive account of a most important subject. There are more than 700 diagrams, all very well drawn and reproduced. It is difficult to see what advantage there can be in using A-B to designate the line AB, or A-B-C to designate the angle ABC. In view of the alarming increase in the prices lately charged for scientific books, it is a pleasure to note the excellent get-up of Mr. Wolfe's book and its moderate price. S. B.

*The Horniman Museum: A Handbook to the Collections illustrating a Survey of the Animal Kingdom.* By H. N. Milligan. Second edition. Pp. 66. (London County Council, 1922.) 6d.

THIS is really an elementary account of the animal kingdom on the usual lines of descriptive zoology. It does not seem to refer definitely to any particular specimens placed on exhibition; but no doubt most of the forms mentioned are on view in the museum cases and serve instead of drawings. The statements are generally accurate and as precise as brevity permits. The style is clear, but assumes some familiarity with words not in the vocabulary of the general visitor, such as "retractile," "aberrant," "everted." If the class Myriapoda is retained, this is merely an instance of the "conservative attitude found convenient in a handbook to be used by the general public." To say that *norvegicus* and *rattus* are "specific names" is but to share a common error, and if the phrase "the Thero-morpha contains" is a grammatical howler, it is the only one of its kind in this book. Mr. Milligan has accomplished a difficult task with much success.

*Radioactivity and Radioactive Substances.* By Dr. J. Chadwick. (Pitman's Technical Primer Series.) Pp. xii+111. (London: Sir Isaac Pitman and Sons, Ltd., 1921.) 2s. 6d. net.

SIR ERNEST RUTHERFORD'S words of commendation in the Foreword to this little book are well deserved. "It is a clear and accurate account of radioactive phenomena written by one who has a first-hand knowledge of the facts." "To all those who are interested in the development of our knowledge of this fascinating subject I can strongly recommend this book as a simple, concise, and accurate statement of the main facts and theories." The diagrams are numerous, and, though on a small scale, are remarkably clear. Similar volumes on other branches of modern physics would be welcome.

*The Rural Community.* By Llewellyn MacGarr. Pp. xv+239. (New York: The Macmillan Co.; London: Macmillan and Co., Ltd., 1922.) 8s. net.

THIS book deals in a very elementary fashion with the social and economic factors affecting the agricultural worker, and its chief merit is its extreme simplicity.

### Letters to the Editor.

[The Editor does not hold himself responsible for opinions expressed by his correspondents. Neither can he undertake to return, or to correspond with the writers of, rejected manuscripts intended for this or any other part of NATURE. No notice is taken of anonymous communications.]

#### The Primitive Crust of the Earth.

PROF. COLE'S letter in NATURE of July 8, p. 39, concerning the earliest known rocks—a group of sediments—and their relation to the ortho-gneisses, will, I think, call forth the sympathy of students of African geology. In 1904-1905 I came to the conclusion that the para-schists of Southern Nigeria were older than at least the majority of the ortho-gneisses, and searched—without success—for the real foundation-stones which received upon their surface these earliest sediments.

Later I have suggested that the Turoka Series of para-schists of Kenya Colony may prove the oldest rocks of that part of Africa and have thought that, were the main directions of foliation of the ortho-gneiss mapped throughout that continent, we should find, not directions produced by dynamic metamorphism, but directions indicating the upwelling of granitic batholiths along zones of failure of the primitive crust, *i.e.* foliation swirls on a huge scale akin to those produced by the flood of the Laurentian magma around the disrupted blocks of Grenville sediments. It might be possible to tell what section of the eroded complex was being studied by observations on the frequency of the occurrence of syntectics, the degree of admixture, the proportion of reconstituted sediments to ortho-gneiss, or even by a passage from complete to less complete metamorphism in the invaded rocks.

The newly established surveys of Uganda, Tanganyika Territory and Nyasaland will, one hopes, throw a flood of light upon this fascinating problem of the constitution of the African Archaean.

JOHN PARKINSON.

Athenæum Club, S.W.

#### Action of Cutting Tools.

MR. MALLOCK'S theory of cutting tools (NATURE, August 26, p. 277) is extremely illuminating, but the term "Coefficient of Friction" in his final paragraph seems scarcely justified, as it would imply that the shearing force is always in the same direction and thus independent of the material being cut, of the depth of the cut, rate of feed and tool angles.

In practice even among skilled workers there is considerable variation in the tool angles used, and there is no decided preference by the workman for a tool ground on a fine-grained emery wheel as against one ground on a coarse grindstone; this on very heavy work where the friction might be important. Moreover, the general variation in practical tool angles seems more related to what may be termed the pliability of the material. Thus, for mild steel and wrought iron, angles of  $50^\circ$  to  $55^\circ$  are common, for cast-steel and cast-iron  $60^\circ$  to  $65^\circ$  or  $70^\circ$  are the rule, whereas the brass-finisher's tools are almost flat topped with an angle of  $80^\circ$  to  $85^\circ$ . Copper and aluminium turnings bend very nicely, and thus the sharp tool angle required for them agrees with the pliability theory.

This idea of pliability is not antagonistic to Mr. Mallock's main argument but strongly in support of it, for when a metal yields pliable turnings, these

turnings slide on the upper face of the tool a great deal more than when they break off short as in a friable material. Thus the curly turnings of a pliable material may exert more frictional force on the upper face of the tool, but not necessarily because the coefficient of friction is higher. Pliable turnings can slide and thus cause friction; brittle turnings break off with very little sliding. This may be seen very clearly in the rough turning of gun barrels. With certain tool angles and not too heavy a cut, the turnings curl off and are hot, whereas with a more obtuse tool and even a heavier cut the metal crumbles off and is probably not so hot. In the latter case the surface turned has a corrugated periphery showing the periodic impulsive friction on the tool face. The friction theory thus leads to a plausible explanation of certain forms of "chatter." If the friction on the tool face fluctuates on account of either vibration or crumbling of the cutting, and if the system has a natural period in tune with what may be termed the crumbling wave-length, resonance occurs.

But for practical difficulties Mr. Mallock's theory might be of value to investigators of friction, for in no set of actual conditions is it likely that metal slides on metal with more intimate contact than near the point of a cutting tool. Even with cutting lubricants it is doubtful if any liquid reaches the point of the tool unless there is chattering.

In attempting any conception of coefficients of friction between the tool and the cuttings, a further difficulty arises which renders the comparison with clean dry surfaces almost impossible. In some circumstances the cutting of metals produces, in addition to the obvious turnings, a fine smooth powder. This is presumably produced by the abrasion of the cutting on the upper face of the tool, and it may be that this smooth powdered metal acts as a lubricant or ball-bearing for the escaping turning. If so, it would be another of Nature's modes of automatic alleviation—as tears allay the irritation of dust in the eyes, and as the skin is cooled by evaporating sweat.

H. S. ROWELL,

Director of Research,  
Research Association of British Motor  
and Allied Manufacturers.

15 Bolton Road, W.4, August 27.

#### The Smoke of Cities.

WITH reference to Prof. Cohen's article on smoke abatement in NATURE of August 26, p. 269, I should be much interested to know why Manchester smoke is qualitatively so much worse than London smoke. Comparing Guy's Hospital and Gower Street with the University of Manchester—the three places of which I have had sufficient experience to judge—I should judge that the quantity of dirt in one's laboratory is about the same; at any rate it is not obviously less in London and, so far as I remember, the published measures of atmospheric pollution confirm this impression. But the Manchester dirt is far more unpleasant and destructive to one's hands, papers, and apparatus. It seems to contain more very fine sticky particles, which get in everywhere and are difficult to clear off: the London dirt is more gritty and granular, makes things dirty enough but is comparatively easily removed. Any one who has spring-cleaned laboratory cupboards in the two places and essayed afterwards to clean themselves will have realised that the dirt is of quite diverse characters. From what Prof. Cohen says I should judge that London smoke is relatively less domestic in origin than the Manchester product, but it seems difficult to reconcile this with what one

knows of the two places. Does the sort of coal make a difference, or the length of time it is kept before consumption? Or is much of the London dirt dust from other sources than coal fires, dispersed more widely than in the damper Manchester atmosphere?

A. E. BOYCOTT.

Medical School, University College Hospital,  
London, W.C., August 28.

PROF. BOYCOTT'S statement is rather surprising; but I cannot think that the explanation is to be found in the larger amount of domestic smoke in Manchester. One would rather expect the reverse, and I can only suppose that the difference between Manchester and London dirt is due to the larger amount of dust not arising from smoke, as Prof. Boycott suggests. Any difference in the quality of coal used in Manchester and London would scarcely have the effect he describes.

The point is an interesting one and I think could be settled by microscopic examination of specimens from the two towns. Soot is easily identified in this way.

J. B. COHEN.

Thwaite Cottage, Coniston Lake, Lancashire,  
September 1, 1922.

### Waterspouts.

WATERSPOUTS on Lake Victoria are very commonly seen from Entebbe, but at a long distance away, and though I have worked on the lake shores for nearly four years it was only two days ago that I first saw one near enough to be of real interest.

I was in camp on the north end of Bugalla, the largest island of the Sese Archipelago. The camp lay about 300 yards from the shore of a small bay. At daybreak on June 30 there were very lowering black clouds and every indication of an immediate heavy storm. While looking out from the tent I suddenly saw that a waterspout was travelling obliquely towards us, and as it eventually came to within about 700 yards of the shore a very good view was obtained for about five minutes before it came to an end.

The pedicle arose from a well-marked circular area on the water, which was otherwise only faintly rippled by the preliminary puff of wind before the approaching storm.

This circular area was evidently very violently disturbed as a cloud of vapour, greatly agitated, rose from it for a little distance.

The pedicle was extremely narrow at its lower end, and not quite straight, being sinuous in outline. It broadened out gradually into a column which went up into the low cloud; the core of this column was much less dense than the periphery, and the violent upward spiral ascent of the water could be clearly seen.

So far I have described nothing unusual, but the following was quite new to me and seemed of great interest.

Surrounding the central core, but separated from it by a clear narrow space, was a sheath, the lower end of which faded away some distance above the water. The profile of this sheath was undulating, it being thicker in some places than others. A curious point is that this sheath *seemed* to pulsate rhythmically, but I could not say whether the appearance of pulsation might not have been an illusion caused by waves travelling up its outer surface.

This pulsation gave an uncanny suggestion of a live thing, which was aided by the violent spiral movement upwards in the central core, the clouds of vapour boiling round its base, and the movement of

the whole across the water—indeed, we watched it spellbound until the pedicle dissolved away at the bottom, and the ascent of the part above brought the phenomenon to an end.

My wife watched with me, and is in entire agreement about the curious appearance of pulsation of the outer sheath.

Fig. 1 is a reproduction of a pencil drawing which

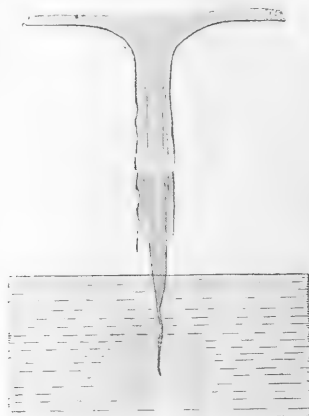

FIG. 1.

may give some idea of what we saw. I cannot estimate the height to which the column rose. Its cessation was followed by violent rain and thunder.

G. D. HALE CARPENTER,  
Uganda Medical Service.

Entebbe, Uganda, July 1.

DR. HALE CARPENTER'S letter brings out one feature which has never, to my knowledge, been noted in a waterspout, namely, the sheath, separated from the main body of the whirl by a clear space. Wegener, in his book on "Wind-und Wasser-hosen in Europa," gives illustrations of a large number of waterspouts, but in no case is there mention of two trunks one within the other. The nearest approach to the phenomenon noted by Dr. Hale Carpenter is the not infrequent occurrence of waterspouts which show two clearly defined parts, an upper thick column with a lower whirl of much smaller thickness.

The accepted explanation of waterspouts is that they consist of whirls in rapid rotation with a discontinuity at the outer boundary. The rotation produces a rapid lowering of pressure within the whirl, and consequently a lowering of temperature, which may easily be sufficient to bring the air in the whirl down below its dew point. This is sufficient to explain the main features of the typical waterspout. The amount by which the temperature is lowered decreases outward from the "axis" of the whirl, while the difference between the air-temperature and dew point normally increases downward from the cloud level. The thickness of the visible column or zone of condensation therefore diminishes downward, giving the form of an inverted cone of irregular shape. Near the water the air is again near saturation, and the difference between air temperature and dew point is small, so that the base of the whirl is

widened. It frequently happens that the portion at middle heights is not visible, on account of the relative dryness of the air.

F. J. W. Whipple (*Meteorological Magazine*, February 1922), writing on cloud pendants, shows that within a whirl of 20 metres diameter, rotating once in a second, with a lowering of pressure of 30 mb. at the centre, the maximum wind speed would be 70 metres per second, or 160 miles per hour, in agreement with winds estimated in tornadoes. A deficiency of 30 mb. pressure represents a suction sufficient to support 1 foot of water only. The solid appearance of a waterspout is therefore not to be ascribed to the lifting up into the air of a solid column of water, but is due partly to the condensation of water vapour within the whirl itself, and partly to water drops which are carried upward in spiral paths. This upward motion of water drops is a well-marked feature of most waterspouts.

The existence of an outer sheath, separated from the central core by a clear space, would appear to require a discontinuity of water content of the air, symmetrical about the axis of the whirl. It does not appear possible to explain it even as the effect of discontinuities of velocity within the whirl. No physical explanation of this clear space can be suggested.

It is usually suggested in text-books (for example, Humphreys's "Physics of the Air," p. 213) that waterspouts are formed at the boundaries of wind currents of different directions. But as such boundaries are of considerable extent, it is difficult to understand why single waterspouts ever come into existence. One would rather expect to find large families of waterspouts distributed over a considerable area. It is true that usually several are seen at the same time, but isolated cases are not infrequent.

The fact that Dr. Hale Carpenter, while standing within about one hundred yards of the waterspout he describes, apparently felt no wind from the whirl, testifies to the very limited diameter of the whirl in question.

D. BRUNT.

Meteorological Office, Air Ministry,  
Sept. 1.

### Periodic Structure of Atoms and Elements.

A. C. CREHORE, in his recent papers on "The Hydrogen Molecule" in the *Philosophical Magazine* (October 1921, May 1922, and June 1922), makes use of the specially constituted atoms of hydrogen and helium discussed by him, and of a hypothetical atom, the atomic weight of which is  $2\frac{1}{2}$ , to build up some of the other atoms. He uses H particles, hydrogen with charge  $+e$ ;  $\alpha$ -particles, helium with charge  $+2e$ ; and particles of his hypothetical element, with positive charge  $+e$ . I think it is clear that he recognises the need for a helium particle with positive charge  $+e$  in addition, if neutral atoms are to be built up in the way he indicates. In one of his models one of the particles marked 4 is also marked with a dot, and this evidently means that it has a charge  $+e$  only. Calling these particles  $\gamma$ , glucinum or beryllium becomes  $\alpha$ ,  $\gamma$ , H and its structure appears to be  $\gamma-\alpha-\gamma$ , where the hyphens indicate electrons. Its isotope, of atomic weight 12, is  $-\gamma-H-\gamma-H\dots$ , forming a simple ring of unit-charged particles. Nitrogen is  $2\alpha, \gamma, 2H$ , and may have the structure



Fluorine, instead of having the constitution assigned to it by Crehore, may be  $2\alpha, 2\gamma, 3H$ , and may have either of the two following structures:

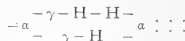

the  $\alpha$ 's joining up to form a ring, or

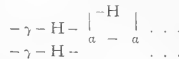

the two  $\gamma$ 's joining up to the  $\alpha$  on the right to form a ring.

Starting from the element of lowest atomic weight in each of the groups of the periodic table, I have found it possible to build up all the other elements of these groups, with atoms of distinctly similar structure for each group, and marked differentiation between the different groups. This has already been carried out up to uranium for nearly all the groups, so that hypothetical models, of the correct atomic weight and atomic number, could now be constructed for the majority, and probably for all, of the known elements and their actual and probable isotopes. Uranium (U.I.) has been assigned the structure

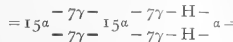

forming a ring-shaped chain of thirty-one  $\alpha$ -particles joined up by two equal chains of  $7\gamma$  particles and two other equal chains of  $7\gamma$  and one H particle. This type of structure may be assigned to elements of Group VI.

H. NEWMAN ALLEN.

3 Lexham Gardens, Kensington, W.8,  
Aug. 26.

### Transmission of Sound of Explosions.

READERS of NATURE may be interested to know that a Commission appointed a year ago for investigating the transmission of sound of explosions is arranging for an experiment on this subject to take place on a day to be notified as soon after September 23 as the weather will permit.

On this occasion it is the War-Minister of the Netherlands who has been able to assist the Commission by notifying it of the intention to explode, on the day to be appointed, some 10,000 kilogrammes of perchlorate of ammonium at 19.30 (western European time); the main explosion will be preceded by a small explosion of a mass of 500 kilogrammes at 19.25.

I learn these particulars from Prof. Van Everdingen, director of the Meteorological Service of the Netherlands, who tells me that the countries surrounding the locus of explosion—Oldebroek, Lat.  $52^{\circ} 29' 56''$  N., Long.  $5^{\circ} 59' 40''$  E.—within 500 kilometres, are being invited to instruct their observers to watch for evidence of the explosion.

NAPIER SHAW.

Sept. 18.

### Research and Razors.

THE incident referred to by Principal Irvine (NATURE, Sept. 16, p. 385) may have been in connexion with Faraday's work on special steels. These were not, I think, a success so far as their use for razors is concerned, so that the present was appropriate. In any case Faraday had little to complain of, since the modern manufacturer does not send even razors.

J. R. PARTINGTON.

45 Kensington Gardens Square, W.2.  
Sept. 16.

Human Geography: First Principles and some Applications.<sup>1</sup>

By MARION I. NEWBIGIN, D.Sc.

IT is a curious fact that, although geographers are agreed that man's intelligence and power of acquiring and transmitting knowledge so differentiate him from animals that it is necessary to distinguish between human geography and animal geography, yet, so far as I am aware, little detailed consideration has been given to the question as to the respects in which his response to environmental conditions differs from that of the animals. This is unfortunate, more especially since, thanks to the biologists, we have a fairly clear idea as to the mechanism of the response in the latter case.

If, for example, we take two familiar animals, such as the rabbit and the common hare, we find that, though belonging to the same genus, and generally resembling each other in structure, they show certain minor differences in bodily form and habits fitting them for their respective environments. The biologists are broadly agreed that these differences are an adaptive response to the different environments of the two animals. In explaining the origin of that adaptive response, most of them lay stress on the two factors of fixation to a particular environment and isolation—actual or physiological—within it, so that incipient variations are not swamped by intercrossing. Now when we turn to man, two facts are at once apparent. First, at the present time, he does not appear to respond to environmental influences by adaptive modifications of bodily form. Secondly, there was certainly a time, before he had come fully to his heritage, when he did so respond. We know this because the anthropologists are agreed that while man once ran into a number of species—and of genera—now all living human beings belong to the same species, and even the races show marked signs of being in process of becoming swamped by intercrossing. In other words, there was a time when there was no human geography, when man reacted to the sum total of the conditions as an animal does; but that time appears largely to have passed.

But there is certainly still a human response to environmental conditions. What precise form does it take? To a certain minor extent, apparently as an inheritance from what I regard as essentially the pre-human period, there is a direct structural response. But man's real response to the surface phenomena of the earth takes the form of a communal, not an individual response. It is the aptitudes which the members of a community display, the tools which they use, the kind of knowledge which they accumulate, their modes of organisation, their type of material wealth, their traditions and ideals, which show the environmental imprint most closely—far more closely than the colour of their skins or the shape of their heads.

But when and how did the change in the two modes of response come about? To answer this question let us recall what has been already said as to the importance of fixation and isolation in the case of animals. The surface of the earth is almost infinitely diverse, and what the biologists call natural barriers, the major

barriers like deserts, seas, and mountain chains, or the minor ones produced by the transition from one type of plant formation to another—*e.g.* from the forested river valley to the grass-covered upland—separate different types of environment, and form obstacles to the distribution of most land animals. There must have been a time when groups of men, no less than the pigs in the forest or the asses on the steppe, were firmly gripped by the physical conditions, were isolated from other groups, and forced to become fitted by structure and habit for a particular set of conditions, or to die out. But with his growing intelligence man escaped from this iron grip, learnt to make virtually every part of the surface yield enough for survival, and proved capable of overcoming every kind of natural barrier. When this occurred the old mechanism of adaptation largely—though not completely—ceased to work. Evolution then might have ceased also, man might have become specially fitted to no environment because fitted for all, if the factors of fixation and isolation had not, in quite a different fashion, obtained a new hold.

Man ceased, save in relatively few parts of the earth's surface, to be a continuous wanderer. He settled down afresh on particular parts of it, and there learnt to use his increasingly complex brain not only in utilising to their full the natural resources, but also in modifying the local conditions so that new resources became available. In other words, I wish to suggest that the cultivation of the soil was the great agent in ensuring the new type of fixation to a particular area which once again made evolution possible. But evolution now took the form of increasing development of communal life, or, in other words, the growth of what we call civilisation is the precise equivalent of specific differences in plant or animal.

Further, just as, in the case of the animal, isolation is necessary before an incipient species can become fixed, so in the case of human communities a measure of protection from the inhabitants of neighbouring areas—a measure, that is, of isolation—is essential before civilisation can develop.

Again, in the case alike of plants and animals we know that where the local conditions are such that the incipient species is limited to a very narrow area, highly specialised forms of adaptation may occur, as they do, for example, on many islands, or in isolated mountain chains; but that specialised type of development is associated with the loss of the capacity to vary, to acquire adaptations fitting the organism for a wider area. So in the case of human communities, where the isolation is too complete the power of adaptation tends to be lost, and such groups, though their civilisation may, along its own lines, be of a highly specialised type, are easily overwhelmed when contact with the outside world does occur, just as island animals tend to disappear before introduced forms.

With these general statements as starting-point, let us consider some facts in regard to the development of civilisation in Europe and the margins of the adjacent continents.

In this area history has seen three successive great

<sup>1</sup> From the Presidential Address delivered to Section E (Geography) of the British Association at Hull on Sept. 7.



foei of civilisation, each based on well-marked and distinctive geographical conditions. The development of the three types has been successive and not simultaneous, and there has thus been a steady shift in time of the main focus, a shift westward and north-westward. The three types of human societies alluded to are, of course (a) the river valley type as represented in Babylonia and early Egypt; (b) the Mediterranean type on parts of the seaboard of the Midland sea; (c) the forest type of Europe proper, itself becoming progressively more and more influenced by the greater ocean to the west, so that forest influences have steadily given way to maritime ones.

It is not necessary to consider the geography of these areas in detail. But, beginning with Babylonia and Egypt, I should like to put the causes which seem to me to have promoted fixation quite briefly. Among them we must certainly include the primitive natural resources, scanty though these doubtless were. The birds of the valley marshes, the relatively small number of mammals, the fish of the rivers, must have supplied a certain amount of the animal food. The date palm, in the Tigris-Euphrates areas at least, would, even in its wild state, doubtless yield a fruit of some value in the very early days.

But as an important factor in the development of cultivation, I would lay especial stress upon the presence of what the botanists call the "open" plant formation. Native trees, as we know, are very few, the date palm, one of the most characteristic, being strictly limited in distribution by its need for water at the roots. For the greater part of the year the ground between the scattered trees is naturally either devoid of vegetation, or is represented only by a few desert plants. But after the periodic flooding by the rivers, an abundant growth of vegetation springs up. The plants may be annuals, the seeds of which ripen as the ground dries, and lie dormant till moisture comes again; or they may be bulbous and tuberous forms, having but a short period of vegetative activity, but possessing underground stems capable of withstanding prolonged drought. The result is that man did not require to clear land for crops; Nature periodically cleared it for him. He had but to make the fairly obvious deduction that water alone was necessary for the apparently barren soil to blossom like the rose; from all the choice of plants which the flooded ground offered, he had to pick out those of some use to him, and learn to suppress the rest. As has often been pointed out, he had no need to trouble greatly about renewing the fertility of his lands, for the flood-water did this for him.

So soon as he had learnt the initial lessons of cultivation, he was tied to the area normally flooded at certain seasons, or to which he could lead the flood-water. He intercalated his crops along one of Nature's lines of weakness, in a transitional area which passed periodically from one climatic zone to another, being, according to the seasons, either a desert or fertile.

The bordering desert ensured isolation, and, continuing the island metaphor, we may say that it represented the sea. Its effect was to throw the whole energy of the community towards the centre, for the periphery formed an area in which the characteristic mode of life could not be practised. Similarly, it gave protection, for it is unsuited to any save a highly

specialised culture, which must have been of relatively late origin. So far as it formed the boundaries of the incipient state, therefore, the desert constituted a barrier preventing the ingress of potential foes. In neither case, of course, was the desert rim complete, and the conditions upstream varied in the two areas, and were, as has often been pointed out, from the point of view of safety, on the whole less favourable in the case of Babylonia than in that of Egypt.

As to the third point, it is, I think, easy to show that while the isolation of the areas was markedly conducive to the rise of civilisation and to its growth up to a certain point, in the long run it became a danger. First, the contrast between the belt which could be watered and that to which, with the means available, water could not be carried, was exceedingly sharp. There was little possibility of a gradual spread into areas becoming slowly but progressively different, where new aptitudes could be acquired, new experience gained, and new forms of wealth stored. Specialisation was high within the favoured tract, but the limits set by Nature could not be passed.

Again, as has often been noted, the conditions led necessarily to a centralised and imperialistic form of social organisation. If there was a sharp line of demarcation between the areas which could and could not be watered, there were great possibilities in the direction of extending by artificial means the belt over which the flood-water spread. This involved the gradual growth of an elaborate irrigation system, and for the maintenance of this a centralised power was essential. This brought with it, as a correlated advantage, the possibility of organised defence when developing neighbouring communities attempted to encroach. But if the attack was made with sufficiently powerful forces, the centralisation became a menace. An attacking foe able to destroy or damage seriously the irrigation system could cut off at its source the basis of prosperity, and render reconstruction on the old scale almost impossible. In other words, the community became adapted to artificial conditions created by itself; if and when those conditions were destroyed, the survival of the old culture became impossible.

Turn next to the Mediterranean region, that is, to the area in which the typical Mediterranean climate prevails. In so far as the native plants are concerned, this area shows certain broad general resemblances to the river-valleys, with some striking differences. Thus the characteristic plant formation is alternately open and closed; closed during the cooler season of the year when the winter rains cause a brief but intense growth of annuals and bulbous or tuberous plants, open during the drought of summer when the trees and shrubs stand apart from each other with bare earth between. But the contrast is due, as indicated, to the rainfall conditions, not to flooding. There is thus no natural renewal of fertility, and plants which require much water can only thrive in the cooler season, so that growth is less intense than in either the Nile or the Euphrates-Tigris valley.

On the other hand, because of the climatic conditions, trees and shrubs, alike as regards individuals and species, are far more numerous represented in the Mediterranean region. Here, however, we come to a

very curious fact, which, though it is familiar enough, does not seem to have been considered in all its bearings. This is that, despite the (relative) wealth of native species of shrubs and trees, those which are cultivated seem to have been for the most part introduced. This is apparently true even of the supremely important olive. The tree occurs in the fossil state, and the olivaster of the maquis is believed by many to be truly wild, not feral. Yet it would appear almost certain that the *cultivated* olive was introduced, into Europe at least. The same thing is true of great numbers of other species, and of all the fruit-bearing trees now grown in the area there are few indeed which can be reasonably regarded as having originated there as cultivated forms. Now, the deduction that I would draw is that the Mediterranean area is one in which lessons first learnt elsewhere could be easily practised, but one rendered unsuited by the natural conditions for the taking of the first steps.

Man was doubtless first attracted to the area, as in the case of the river-valleys, by the natural resources, small though these must have been, even with the addition of the sea fisheries. He became fixed to it when he learnt that the hill spurs gave safe sites for settlements, while affording easy access to the slopes on which he could carry on his special form of intensive cultivation. That form, as already suggested, was a derived and not an original one. He replaced the native trees and shrubs by useful cultivated varieties or species, which had, certainly for the most part, originated elsewhere. He intercalated short-lived annuals like corn crops and beans along the line of weakness indicated by the periodic opening and closing of the natural vegetation. But one of his great difficulties was always that the absence of much level land and the climatic conditions rendered the growth of such crops relatively difficult, much more difficult than in the river-valleys.

If we think of the early settlements as showing a general resemblance to the Berber villages of the Algerian Atlas to-day, we realise that they were more or less isolated from one another, so that the social polity was of a wholly different type from that existing either in Babylonia or in early Egypt. But, and this seems to me important, although the natural conditions—especially the fact that fertility was limited to certain areas—made a measure of isolation inevitable, yet the sea gave a possibility of free movement in all directions which was absent in the river-valleys. Thus oversea, if not overland, spreading could take place, and the changes in the geographical conditions as the sea is traversed westward are relatively small, not outside the limits of adaptation. Thus we have the spread of the higher forms of Mediterranean culture from the eastern end of the sea towards the west, with the founding of new settlements of generally similar type to the old. This possibility of free movement brought with it a wider range of adaptability, a constant willingness to profit by new experiences, which has proved of enormous value to the world at large.

But with all its advantages the Mediterranean area, as already stated, had the great disadvantage that bread-stuffs were difficult to produce in quantity. Two methods of getting over that difficulty could be and were practised. For example, the ancient Greeks,

having, it would appear, learnt the lesson from the Phœnicians, dared, in course of time, to descend from their hill-spurs to the sea-coast, in order to supplement the scanty resources of their limited lands by sea-trading. After a long interval the medieval cities, especially of Italy, did the same thing on a greater scale and with the advantage of a wider market. Between the two periods Rome tried the other possible method, that of holding in subjection the areas, outside that of the characteristic climate, which were corn-producing. Her failure was, at least in part, due to geographical causes. The great advantage of the method of sea-trading was the increase in the power of adaptation which it brought, as a result of the continual peaceful contact with other lands and other peoples. The decay of the splendid medieval cities of Italy came when the Mediterranean ceased to be a great highway of commerce, and the vivifying breezes from the outside world which had swept through it took another course—once again, therefore, a civilisation based upon a delicate adjustment to a particular set of conditions fell when those conditions changed.

Let us turn next to the third great area where, comparatively late, a complex civilisation grew up, that of the forest belt of Central and Western Europe. Here the conditions appear relatively so unfavourable that man could scarcely have solved the problem of fixing himself permanently to particular areas, and adapting himself to them, were it not for the help of the experience gained elsewhere. The great agent in transmitting that experience was, of course, first the Roman Empire, and then the Church which was the direct heir of the empire.

The essential difficulty here was that the characteristic plant formation was the closed temperate forest. At first sight there appears to be within it no line of weakness along which cultivated plants can be intercalated, and the establishment of cultivation seems to depend upon the complete destruction of the natural vegetation, involving the slow and peculiarly laborious clearing of the forest. Had the temperate forest been in point of fact as continuous as we are apt to assume, the problem would have been so difficult that the hunter's life in the forest might have lasted much longer than it did. We know, of course, that there were always "islands" in the sea of green, and of these the most important, from the point of view of the development of cultivation, were the loess areas and the lower uplands, especially those over chalk. We have, therefore, as our starting-point in this case scattered settlements in the woods—not compact ones like those of the Mediterranean region. As to the next stage, the surrounding wood must be regarded from two points of view. Initially it formed a protection, the protective influence being strongest where the ground was ill-drained, owing to the dense thickets which covered the marshy ground. But, in contrast to both the types of region already considered, given the necessary tools for the clearing of the land, the particular type of cultivation could be extended almost indefinitely on the level, while leaving the woods on the rising ground to supply the necessary fuel, building material, and pannage for the swine. This was a great advantage, but it meant that the necessary protection was soon lost.

In North-Western Europe that protective influence was peculiarly necessary for one geographical reason, as it was on the eastern margin of the continent for another. It was necessary in the west especially, because the sea-coasts, owing to the local wealth of fish, early attracted population. But in many regions those coasts, exposed to the oceanic type of climate in its most pronounced form, were unsuited to cultivation. At the same time, on account of their sheltered inlets, parts of those coasts were well fitted to breed a seafaring folk. Unable, or able only to a very small degree, to supplement their natural resources by cultivation, having at the same time command of the sea, those seafarers tended constantly to raid the painfully cleared and cultivated lands of their more fortunately situated neighbours, who, time and again, found their encircling woods a protection. We must suppose, therefore, that the tendency to clear more and more land would be checked by this need for the shelter of the woods.

But it seems to me that we may regard the growth of feudalism, from one point of view, as an adaptive device by which the growing agricultural settlements obtained, at a price, the necessary protection. Feudalism, in the form, for example, in which it grew up in England before the coming of the Normans, was a means of ensuring the existence of a kind of organisation which permitted clearing of forest land to go on indefinitely, while diminishing the risk of perpetual raiding.

It was also, more especially in Eastern Europe, something more, for it tended to fix the cultivator to the land. The tendency to wander may be said to be almost universal in the case of forest-dwellers carrying on primitive agriculture. Its wide distribution is due to the great difficulty of maintaining there the fertility of the land, more especially when exhausting crops, like the different kinds of grain and flax, are grown.

Feudalism helped in the solution of this problem by checking the natural tendency of the cultivator to abandon exhausted lands and move on to new ones. But even apart from this particular device, the problem of maintaining fertility had to be tackled early in the West, because the relief made the forest far less continuous and uniform than in the East. It must have been obvious quite early that it was not illimitable. Conditions were different in the forest region of the East, where the vast, almost uniform plains, the absence of well-marked relief, and the breadth of the continent made the forest a more permanent and unmanageable element than in Western Europe. Here, therefore, we find in suggestive combination two peculiar features. The first is that the wandering instinct, the instinct that brought the Slavs from their eastward forest home far into Central and Southern Europe, still persists. It is said to be quite well marked in parts of Russia, despite all the artificial checks which existed under the old regime. Part of the difficulty of the Slav problem also lies in the fact that the effect of the habit of small groups of wandering constantly from one wooded tract to another is written large on the ethnological map.

The second peculiar feature is that feudalism, and feudalism in a very harsh form, survived here far

longer than in Western Europe, and in fact, if not in law, had scarcely disappeared when the war broke out. I would suggest that the great significance of this form of social policy here was that it helped to counteract the effects of the natural conditions, that it was fundamentally an artificial device for rendering the population stationary, and enabling it to adapt itself to the local relief and associated phenomena.

Now, whatever its value in earlier days, the present chaos in Eastern Europe shows clearly enough that ultimately it checked social evolution, and became a serious menace. It was fundamentally the erection of an artificial barrier round the rural community, and led to the apparent loss of the power of slow adaptation to changing conditions, alike on the part of the overlords and of the freed serfs.

But in the eastern chaos another factor has to be borne in mind. In the Old Russia, south of the forested area, and extending both into what is and was Rumania, lie the great treeless plains. Parts of these, as the nineteenth century showed, are extraordinarily fertile and well adapted for cereal production. But, from the point of view adopted here, they suffered from the enormous disadvantage that there is nothing in the natural conditions to fix their inhabitants to special areas, thus enabling them to acquire qualities fitting them for life there; nothing to give protection from constant inroads from Asia. Literally wastes for long centuries, these plains were for the most part ultimately incorporated in Imperial Russia, and deliberately colonised, often with colonists from a distance. The colonists were brought from areas of other characters, possessed traditions and aptitudes due to long experience of different geographical conditions, and were in the grip of a Government which had itself evolved under those conditions. There was thus no question of the possibility of the evolution of a type of culture bearing the imprint of the local conditions.

In consequence Russia to-day—as well as to some extent Rumania—is faced with a double problem. In both regions parts of the constituent lands are fitted for the mixed cultivation of the forest belt, and in them the old social policy has shown itself unfitted for modern conditions, and a new one has yet to be evolved. Other parts, again, have never developed even an imperfect social policy which was a response to their own local environment. Their apparent prosperity, till the outbreak of the war, was due to the fact that they were, economically though not politically, of the nature of colonies in relation to the industrialised West; they were, fundamentally speaking, the equivalents of Imperial Rome's corn-producing lands in North Africa and the Danubian plains. The chaos in Eastern Europe is thus having a reflex disturbing effect upon the West. The West has lost an important market, but that is perhaps in itself less important than the fact that over a large tract of European land man and his environment have been thrown out of gear, a catastrophic condition which inevitably disturbs equilibrium elsewhere. Just as in the later days of the Roman Empire disturbances in the marginal corn-producing lands shook and ultimately overthrew the centre, so are the centres of Western European civilisation to-day trembling under the impact of shocks

emanating from the East. We can well understand, therefore, how it is that there are those who believe that the focus of civilisation is destined to undergo another shift, and that the day of the predominance of North-Western Europe is drawing to a close.

The subject is not one which can be discussed here. But if I may sum up briefly the points I have been trying to make, I would say that the human geographer should have before him a twofold purpose. First, he should strive to show that the deductions which the biologists have slowly and painfully laid down in the course of the last sixty years apply, though with an essential difference—which requires careful definition

—to the life of man. Secondly, he should use his precise knowledge of the surface of the earth to work out detailed applications of those deductions. In other words, human geography is the biology of man, and, on account of man's vast power of modifying his environment, necessitates a fuller knowledge of that environment than can be required of the biologist in the narrower sense. Investigations along these lines would, I think, promote greatly the interests of geography as a whole, both by making clear to the general public its value and in justifying that intensive study of the surface relief and the associated phenomena which must always remain its basis.

### Educational and School Science.<sup>1</sup>

By Sir RICHARD GREGORY.

THE Educational Science Section of the British Association, which attains its majority this year, was established to consolidate the claims staked out by workers in different educational provinces, and promote common interest in their development as a whole. As Prof. H. E. Armstrong explained at the opening meeting, it was proposed to devote attention to education in all its branches with the object of introducing scientific conceptions into every sphere of educational activity; that is, conceptions which imply such exact and profitable treatment of a subject as should come from full knowledge. Educational science signifies, however, much more than methods of teaching or the theory of the curriculum. It involves conditions of physical, mental, and moral health, with their manifold types and variations, and the determination of the most appropriate, and therefore most effective, factors of growth at every stage of development. In its present stage educational science must be largely empirical, but in this respect it does not differ from meteorology, for example; and the laws which govern the perpetually varying contents and conditions of a child's mind are not much less precisely known or applied than those by which atmospheric changes are determined.

Education may, therefore, be defined as the deliberate adjustment of a growing human being to its environment; and the scope and character of the subjects of instruction should be determined by this biological principle. What is best for one race or epoch need not be most appropriate for another, but always the aim should be to give the pupil as many points of contact with the world around him as may be profitably developed during his school career. This does not mean, of course, that his vision is to be confined to contemporary necessities or his thoughts to provincial or even national fields. The resources available for his instruction and guidance comprise the wisdom and experience of the past as well as the power of the present, and in their extensive and varied character they now provide teachers with educational opportunities richer and fuller than those of any other period of the world's history. Literature and art form noble domains of the heritage into which the child of to-day is born, but they were mostly planted long ago, and

their shapes have not been altered much in modern times. Science has, however, transformed the whole landscape entrusted to it, and the realm of its productivity is continually extending. It is a kingdom potent with possibilities for good or evil—an inheritance which cannot be renounced—and to let any of our children grow up unfamiliar with their entailed possession is to neglect an obvious duty.

The essential mission of school science is thus to prepare pupils for civilised citizenship by revealing to them something of the beauty and the power of the world in which they live, as well as introducing them to the methods by which the boundaries of natural knowledge have been extended and Nature herself is being made subservient to her insurgent son. We live in a different world to-day from that of medieval times, when the *trivium* of grammar, logic, and rhetoric, with the *quadrivium* of arithmetic, geometry, music and astronomy, comprised the subjects of a complete education in the sciences as well as in letters—different indeed from what it was only a century ago. The influence of science is now all-pervading, and is manifest in all aspects of human activity, intellectual and material. Acquaintance with scientific ideas and methods and applications is forced upon every one by existing circumstances of civilised life with its facilities for rapid transport by air, land, or sea, ready communication by telephone or telegraph, and other means by which space and time have been brought under control and man has assumed the mastership of his physical and social destiny. Science permeates the atmosphere in which we live, and those who cannot breathe it are not in biological adjustment with their environment—are not adapted to survive in the modern struggle for existence.

School instruction in science is not, therefore, intended to prepare for vocations, but to equip pupils for life as it is and as it soon may be. It is as essential for intelligent general reading as it is for everyday practical needs; no education can be complete or liberal without some knowledge of its aims, methods, and results, and no pupil in primary or secondary schools should be deprived of the stimulating lessons it affords. In such schools, however, the science to be taught should be science for all, and not for embryonic engineers, chemists, or even biologists; it should be science as part of a general education—unspecialised,

<sup>1</sup> From the presidential address delivered to Section L (Educational Science) of the British Association at Hull on Sept. 7.

therefore, and without reference to prospective occupation or profession, or direct connexion with possible university courses to follow. Less than 3 per cent. of the pupils from our State-aided secondary schools proceed to universities, yet most of the science courses in these schools are based upon syllabuses of the type of university entrance examinations—syllabuses of sections of physics or chemistry, botany, zoology, and so forth—suitable enough as preliminary studies of a professional type to be extended later, but in no sense representing in scope or substance what should be placed before young and receptive minds as the scientific portion of their general education. Such teaching excuses the attitude of many modern Gallios among schoolboys caring "for none of those things." The needs of the many are sacrificed to the interests of the few, with the result that much of the instruction is inept and futile whether judged by standards of enlightenment or of stimulus. Exceptional pupils may profit by it, but to others, and particularly to teachers of literary subjects in the school curriculum, it often appears trivial or sordidly practical, and is usually spiritless—a means by which man may gain the whole world, but will lose his soul in the process.

This impression is not altogether unjust, and the teaching of recent years has tended to accentuate it. The extent of school science is determined by what can be covered by personal observation and experiment—a principle sound enough in itself for training in scientific method, but altogether unsuitable to define the boundaries of science in general education. Yet it is so used. Every science examination qualifying for the First School Certificate, which now represents subjects normally studied up to about sixteen years of age, is mainly a test of practical acquaintance with facts and principles encountered in particular limited fields, but not a single one affords recognition of a broad and ample course of instruction in science such as is required in addition to laboratory work. I have not the slightest intention or desire to suggest that practical work can be dispensed with in the teaching of any scientific subject, but I do urge that it becomes a fetish when it controls the range of view of the realm of natural knowledge capable of being opened for the best educational ends during school life.

It is now generally recognised by educationists that up to the age of about sixteen years there should be no specialisation in school studies. The First School Examination was organised with this end in view, and seven examining bodies have been approved by the Board of Education to test the results of instruction given in (1) English subjects, (2) languages, (3) mathematics, and science, which constitute the three main groups in which candidates are expected to show a reasonable amount of attainment. The number of candidates who presented themselves at examinations of the standard of First School Certificates last year was about 42,000; and of this number, 12,500 took papers in sections of physics, 13,000 in chemistry, 11,400 in botany, 5000 physics and chemistry combined under experimental science, 113 natural history of animals, 31 geology, and 3 zoology.

These numbers may be taken as a fair representation of the science subjects studied in most of our secondary schools, and they suggest that general scientific teach-

ing is almost non-existent. Botany is a common subject in girls' schools, but the instruction in science for boys is limited to parts of physics and chemistry. The former subject is usually divided into mechanics and hydrostatics; heat; sound and light; and electricity and magnetism; and candidates are expected to reach a reasonable standard in two of these sections. They may, therefore, and often do, leave school when their only introduction to science is that represented by the study of mechanics and heat, and without the slightest knowledge of even such a common instrument as an electric bell, while the ever-changing earth around them, and the place of man in it, remain as pages of an unopened book. They ask for bread, and are given a stone. General science covering a wide field is practically unknown as a school subject, and even general physics rarely finds a place in the curriculum because questions set in examinations are, to quote from the Cambridge Locals Regulations, "principally such as will test the candidate's knowledge of the subject as gained from a course of experimental instruction."

One or two examining bodies have introduced general science syllabuses covering the rudiments of physics and chemistry as well as of plant and animal life, but even in these cases most of the subjects must be studied experimentally, and no place is found for any other means of acquiring knowledge. The result is that few schools find it worth while from the point of view of examination successes to attempt to cover such schemes of work. Moreover, no clear principle can be discerned by which the syllabuses are constructed. General science should be more than an amorphous collection of topics from physics and chemistry, with a little natural history thrown in as a sop to biologists. It should provide for good reading as well as for educational observation and experiment; should be humanistic as well as scientific. The subject which above all others has this double aspect is geography; so truly, indeed, is this the case that in the First School Examinations it may be offered in either the English or the Science group. A school course which would cover all the science required for the study of geography conceived as a branch of knowledge concerned with the natural environment of man and the inter-relations between him and those circumstances would not only be educational in the broadest sense, but would also be the best groundwork for effective teaching of geography, history, and other humanistic studies. It would make science a natural part of a vertebrate educational course instead of specialised and exclusive as it tends to be at present.

It cannot be reasonably suggested that the order in which the usual sections of physics are prescribed has any relation to mental growth, or that the topics selected from them are such as appeal to early interests. Few pupils of their own volition wish to determine specific gravities, investigate the laws of motion, calculate specific and latent heats, and so on, at the stage of instruction in science at which these matters are usually studied, and from the point of view of educational value most of them would be more profitably employed in becoming acquainted with as wide a range as possible of common phenomena and everyday things—all considered as qualities to stimulate

attention instead of quantities to be measured with an accuracy for which the need cannot be seen and by methods which easily become wearisome. The "Investigators" appointed by the Board of Education in 1918 to report upon the papers set in examinations for the First School Certificate were right when they expressed their opinion "that the early teaching of physics has suffered from too great insistence on more or less exact quantitative work, to the neglect of qualitative or very roughly quantitative experiments illustrating fundamental notions." By the prevailing obsession in regard to quantitative work the pupil is made the slave of the machine, and appliances become encumbrances to the development of the human spirit.

When instruction in science was first introduced into schools its character was determined by insight and conviction rather than by mental needs or interests; so later, when practical work came to be regarded as an essential part of such instruction, its nature and scope represented what certain authorities believed pupils should do, instead of what they were capable of doing with intelligence and purpose. Practical chemistry became drill in the test-tubing operations of qualitative analysis, and the result was so unsatisfactory from the points of view of both science and education that when Prof. Armstrong put forward a scheme of instruction devised by him, in which intelligent experimentation took the place of routine exercises, acknowledgment of its superior educational value could not be withheld, and for thirty years its principles have influenced the greater part of the science teaching in our schools.

Prof. Armstrong's particular contribution to educational science consisted in the production of detailed schemes of work in which these principles were put into practice. Ideas are relatively cheap, and it needs a master mind to make a coherent story or useful structure from them. This was done in the courses in chemistry outlined in Reports presented to the British Association in 1889 and 1890, and the effect was a complete change in the methods of teaching that subject. "The great mistake," said Prof. Armstrong, "that has been made hitherto is that of attempting to teach the elements of this or that special branch of science; what we should seek to do is to impart the elements of scientific method and inculcate wisdom, so choosing the material studied as to develop an intelligent appreciation of what is going on in the world." One feature of heuristic instruction emphasised by its modern advocate, but often neglected, is that which it presents to the teaching of English. Accounts of experiments had to be written out in literary form describing the purpose of the inquiry and the bearing of the results upon the questions raised, and wide reading of original works was encouraged. A few years ago English composition was regarded as a thing apart from written work in science, but this should not be so, and most teachers would now agree with the view expressed by Sir J. J. Thomson's Committee on the Position of Natural Science in the Educational System of Great Britain that "all through the science course the greatest care should be taken to insist on the accurate use of the English language, and the longer the time given to science the greater becomes the responsibility of the teacher in this matter. . . . The conventional jargon of laboratories, which is far

too common in much that is written on pure and applied science, is quite out of place in schools."

When heuristic methods are followed in the spirit in which they were conceived, namely, that of arousing interest in common occurrences, and leading pupils to follow clues as to their cause, as a detective unravels a mystery, there is no doubt as to their success. No one supposes that pupils must find out everything for themselves by practical inquiry, but they can be trained to bring intelligent thought upon simple facts and phenomena, and to devise experiments to test their own explanations of what they themselves have observed. It is impossible, however, to be true to heuristic methods in the teaching of science and at the same time pay addresses to a syllabus. A single question raised by a pupil may take a term or a year to arrive at a reasonable answer, and the time may be well spent in forming habits of independent thinking about evidence obtained at first-hand, but the work cannot also embrace a prescribed range of scientific topics. Yet under existing conditions, in which examinations are used to test attainments, this double duty has to be attempted by even the most enlightened and progressive teachers of school science. There can, indeed, be no profitable training in research methods in school laboratories under the shadow of examination syllabuses. Where there is freedom from such restraint, and individual pupils can be permitted to proceed at their own speeds in inquiries initiated on their own motives, success is assured, but in few schools are such conditions practicable; so that, in the main, strict adherence to the heuristic method is a policy of perfection which may be aimed at but is rarely reached.

A necessary condition of the research method of teaching science is that the pupils themselves must consider the problems presented to them as worth solving, and not merely laboratory exercises. Moreover, the inquiries undertaken must be such as can lead to clear conclusions when the experimental work is accurately performed. It may be doubted whether the rusting of iron or the study of germination of beans and the growth of seedlings fulfils the first of these conditions, and the common adoption of these subjects of inquiry is due to custom and convenience rather than to recognition of what most pupils consider to be worth their efforts. It needed a Priestley and a Lavoisier to proceed from the rusting of iron to the composition of air and water, and even such an acute investigator as Galileo, though well aware that air has weight, did not understand how this fact explained the working of the common suction pump.

The mission of school science should not, indeed, be only to provide training in scientific method—valuable as this is to every one. Such training does cultivate painstaking and observant habits, and encourages independent and intelligent reasoning, but it cannot be held in these days that any one subject may be used for the general nourishment of faculties which are thereby rendered more capable of assimilating other subjects. Modern psychology, as well as everyday experience, has disposed of this belief. If the doctrine of transfer of power were psychologically sound, then as good a case could be made out for the classical languages as for science, because they also may be taught so as to develop the power of solving problems

and of acquiring knowledge at the same time. When, therefore, advocates of particular courses of instruction state that they do not pretend to teach science, but are concerned solely with method, they show unwise indifference to what is known about educational values. Locke's disciplinary theory—that the process of learning trains faculties for use in any fields, and that the nature of the subject is of little consequence—can no longer be entertained. It has now to be acknowledged that information obtained in the years of school life is as important as the process of obtaining it; that, in other words, subject matter as well as the doctrine of formal discipline must be taken into consideration in designing courses of scientific instruction which will conform to the best educational principles.

So long ago as 1867 the distinction between subject and method was clearly stated by a Committee of the British Association, which included among its members Prof. Huxley, Prof. Tyndall, and Canon Wilson. It was pointed out that general literary acquaintance with scientific things in actual life, and knowledge relating to common facts and phenomena of Nature, were as desirable as the habits of mind aimed at in scientific training through "experimental physics, elementary chemistry, and botany." The subjects which the Committee recommended for scientific information, as distinguished from training, comprehended "a general description of the solar system; of the form and physical geography of the earth, and such natural phenomena as tides, currents, winds, and the causes that influence climate; of the broad facts of geology; of elementary natural history with especial reference to the useful plants and animals; and of the rudiments of physiology." If we add to this outline a few suitable topics illustrating applications of science to everyday life, we have a course of instruction much more suitable for all pupils as a part of their general education than what is now commonly followed in secondary schools. It will be a course which will excite wonder and stimulate the imagination, will promote active interest in the beauty and order of Nature, and the extension of the Kingdom of Man, and provide guidance in the laws of healthy life.

The purpose of this kind of instruction is, of course, altogether different from that of practical experiment in the laboratory. One of the functions is to provide

pupils with a knowledge of the nature of everyday phenomena and applications of science, and of the meaning of scientific words in common use. Instead of aiming at creating appreciation of scientific method by an intensive study of a narrow field, a wide range of subjects should be presented in order to give extensive views which cannot possibly be obtained through experimental work alone. The object is indeed almost as much literary as scientific, and the early lessons necessary for its attainment ought to be within the capacity of every qualified teacher of English. Without acquaintance with the common vocabulary of natural science a large and increasing body of current literature is unintelligible, and there are classical scientific works which are just as worthy of study in both style and substance as many of the English texts prescribed for use in schools. We all now accept the view that science students should be taught to express themselves in good English, but little is heard of the equal necessity for students of the English language to possess even an elementary knowledge of the ideas and terminology of everyday science, which are vital elements in the modern world, and it is the business of literature to present and interpret them.

It may be urged that knowledge obtained through descriptive lessons has no scientific reality unless it is derived from first-hand experience, and this is no doubt right in one sense; yet it is well to remember that science, like art, is long, while school life is short, and that though practical familiarity with scientific things must be limited, much pleasure and profit can be derived from becoming acquainted with what others have seen or thought. It is true that we learn from personal experience, but a wise man learns also from the experience of others, and one purpose of a descriptive science course should be to cultivate this capacity of understanding what others have described. As in art, or in music, or in literature, the intention of school teaching should be mainly to promote appreciation of what is best in them rather than to train artists, musicians, or men of letters, so in science the most appropriate instruction for a class as an entity must be that which expands the vision and creates a spirit of reverence for Nature and the power of man, and not that which aims solely at training scientific investigators.

### The Royal Botanic Gardens, Kew.

THE area occupied by the Royal Botanic Gardens of Kew, as we know them to-day, is mainly the result of the union of two demesnes, both of them famous in a horticultural sense long before they came to be associated in particular with the science of botany. These two demesnes were, first, the grounds originally attached to a house in the Old Deer Park of Richmond known as Ormonde Lodge, Richmond Lodge, and finally, when it came to be occupied by George II. (then Prince of Wales) about 1721, as Richmond Palace; secondly, the grounds belonging to Kew House or White House, a dwelling that stood near the present Kew Palace, and which, after being occupied by the families of Bennett, Capel, and Molyneux, came into the possession of Frederick, Prince of

Wales, in 1730. On the death of George II. in 1760, both properties came under the ownership of his grandson, George III. At that time they were divided by an ancient bridle-path known as "Love Lane," which ran from Richmond Green to a horse-ferry over the Thames at Brentford. George III. obtained Parliamentary sanction to close Love Lane, with the obliteration of which, in 1802, Richmond Gardens and Kew Gardens became the larger Kew Gardens we know at the present time.

In the aero-photograph here reproduced we are looking almost due north, and most of the area shown belongs to the Kew Gardens of the eighteenth century. It is bounded on the east by the Kew Road, some of the villas of which are shown towards the top right-hand

corner of the picture. It is on this area that all the plant-houses, museums, and other buildings are situated. Richmond Gardens were bounded on the west by the Thames, and part of their site is the thickly wooded area shown towards the top left-hand corner of the photograph.

Under Queen Caroline, consort of George II., Richmond Gardens became famous for the costly and elaborate operations she carried out there. She built Merlin's Cave, the Hermitage, and various temples and other structures, all of which disappeared soon after George

It was here that his friend Dr. Bradley, afterwards Astronomer Royal, made his two important discoveries, the aberration of light and the nutation of the earth's axis. Kew House was pulled down in 1802, but the site of the observatory and Bradley's discoveries is now marked by a sun-dial.

The foundation of the Botanic Garden at Kew has to be credited to Augusta, Princess of Wales and mother of George III. Under the superintendence of Lord Bute, about nine acres were laid out in 1760, the portion devoted to herbaceous plants, then called the



THE ROYAL BOTANIC GARDENS, KEW.

(Photo by Central Stereograph Co., Ltd.)

A= PAGODA. B= TEMPERATE HOUSE. C= REFRESHMENT PAVILION. D= N. O. GALLERY. E= FLAGSTAFF. F= PALM HOUSE.  
G= WATER-LILY HOUSE. H= NO. III. MUSEUM (ORANGERY). I= KEW PALACE. J= POND. K= CACTUS HOUSE.

III. came to the throne. Even Richmond Lodge itself was razed to the ground in 1772.

The old Kew Gardens had a longer and more interesting history. John Evelyn made several references to them in his Diary. In August 1678 he records that the gardens had the "choicest fruit of any in England," and under the date February 24, 1688, he wrote, "we went to Kew to visit Sir Henry Capel's whose orangery and myrtetum are most perfectly kept." From the accounts of Evelyn and others it appears certain that, even 250 years ago, Kew was one of the best gardens in England.

Sir Henry Capel died in 1696, and the property descended to his grand-niece, the wife of Samuel Molyneux. Molyneux had a taste for astronomy and converted part of Kew House into an observatory.

Physic Garden, being arranged on the then newly devised Linnaean System. William Aiton, a pupil of Philip Miller of Chelsea and afterwards the author of the "Hortus Kewensis," was appointed head gardener, and Sir William Chambers, the architect of Somerset House, erected a number of temples and other buildings, of which several, including the Pagoda, are still conspicuous features of the place.

Between 1760 and 1841 Kew had a period of brilliant success and one of decadence. Princess Augusta died in 1772 and George III. substituted Sir Joseph Banks in place of Lord Bute as unofficial director of the Botanic Garden. Banks was largely interested in the fortunes of the garden until his death in 1820, and his association with it no doubt was the chief agency that ultimately gave it the premier position among



botanic gardens of the time. Plant collectors were despatched to various countries, the first being Francis Masson, who went to South Africa in 1772.

After the death of George III. as well as that of Banks in 1820, the gardens gradually declined in efficiency and repute, until at the accession of Queen Victoria there was a serious danger of their disappearance altogether as a botanic establishment. However, a committee of inquiry, headed by John Lindley, reported strongly in favour of their continuance and further development, and in 1840 their control was vested in the Commissioners of Woods and Forests. In 1841, Sir William Hooker was appointed director, and thus was inaugurated the second great period in the history of Kew.

During the last eighty years the area devoted to botany and horticulture has increased from about 15 acres to 288 acres. Its work as the botanical centre of the British Empire and for the distribution of economic plants to all our colonies and possessions is well known. To the public generally it is, of course, best known as a popular resort. Nor must its place as a training school in horticulture be forgotten, especially for curators of Colonial and Indian Botanic Gardens and superintendents of public parks at home. No better testimony of its value to the Empire can be adduced than that of Joseph Chamberlain, then Colonial Secretary, in the House of Commons on August 2, 1898: "I do not think it is too much to say that at the present time there are several of our important colonies which owe whatever prosperity they possess to the knowledge and experience of, and the assistance given by, the authorities at Kew."

In pure botany its chief work has been the preparation and publication of Floras of British possessions—a botanical survey of the Empire. Bentham and Hooker prepared their "Genera Plantarum" at Kew, and the monumental "Index Kewensis" was compiled there. The Herbarium contains some 2,500,000 specimens and the library upwards of 24,000 volumes.

Turning to the more conspicuous objects in the accompanying illustration, the one that catches the eye first is the Pagoda (A). This was erected by Sir

William Chambers in 1761-2; it has ten storeys and is 163 feet high. From its summit the Crystal Palace is usually visible and, with a favourable atmosphere, Windsor Castle. During the coal strike in the spring of last year all the more lofty buildings as far as St. Paul's could be seen.

The Temperate House (B) is a structure of three main compartments, the large central one, built in 1862, being devoted largely to the cultivation of Australian and New Zealand trees and shrubs, the smaller ones, built 1897-1899, to Himalayan and subtropical ones. The North Gallery (D) contains 848 paintings of flowers and tropical and subtropical vegetation by the late Marianne North; both the paintings and the buildings were presented by her to Kew in 1882. The Flagstaff (E), which appears merely as a dark streak in the illustration, was presented by British Columbia, and is 214 feet high, 2 feet 9 inches in diameter at the base, 1 foot in diameter at the summit; at the time of its erection in October 1919 it weighed 18 tons.

The Palm House (F), where tropical plants, such as palms, cycads, pandanads, bamboos, and bananas, are grown, is an iron structure built 1844-1848. It is 362 feet long and 66 feet high in the centre. The Orangery (H) is one of Chambers's buildings and was erected in 1761. The orange trees originally housed there were transferred to Kensington Palace in 1841, soon after Kew became public property. It is now known as Museum III. and contains exhibits of exotic timber and miscellaneous objects.

Kew Palace (I), once known as the Dutch House, is a red brick, Jacobean dwelling, built by Samuel Fortrey in 1631. By his grandson it was sold to Sir Richard Levett, who was Lord Mayor of London in 1700, and in 1781 it was purchased from the Levetts by George III., who used it as a dwelling for himself and his large family when the Court was at Kew. His sons, the Dukes of Clarence and of Kent, were married in one of the rooms, and his wife, Queen Charlotte, died there November 17, 1818. It is now open to the public who visit the Gardens, but is not attached in any scientific sense to the establishment, containing only mementoes of the Royal Family.

## Obituary.

DR. R. H. CODRINGTON.

IN the fulness of years, at the age of ninety-two, Dr. R. H. Codrington, the apostle of Melanesia, has passed away. After a distinguished Oxford career he became Fellow of Wadham; soon after, he joined Bishop Patteson and afterwards lived with Bishop Selwyn at Norfolk Island. After thirty-two years' service in the Melanesian mission he returned to England and became vicar of Wadhurst and Prebendary of Chichester. A friend who knew him well describes him as "the soundest of scholars, kindest of teachers, most practical of saints, most genial and tolerant of friends." He will be remembered as the first and greatest ethnologist and linguist who studied the people of Melanesia. His fame rests on two great books—"The Melanesian Languages," and "The Melanesians, their Anthropology and Folk-lore," published by the Oxford Press in 1855-1891. The

former laid the foundation of the scientific knowledge of the speech of that region; the second is invaluable to the anthropologist as giving the first and fullest account of religious beliefs. Dr. Codrington was also the discoverer of the principle of Mana, which has played a leading part in the exploration of savage religion since he made it known to the world.

The *Chemiker Zeitung* for September 5 announces the death on August 7 of Prof. Emilio Noelting, for many years Director of the Chemical School at Mülhausen. Prof. Noelting was an authority on dye-stuffs; he was born on June 8, 1851, at Porta Plata, San Domingo, and after study at Zürich he took up his position at Mülhausen in 1880. In the issue for September 9 of the same journal the death is announced of Prof. E. Bergmann, director of the Chemisch-Technische Reichsanstalt, Berlin.

## Current Topics and Events.

STAGNATION of trade in the year 1921 is responsible for a situation in the American dyestuff industry resembling, in many respects, that which prevailed in this country. Firms engaged in the manufacture of coal-tar derivatives numbered 201, of which 74 produced colouring-matters with an output of 39,000,000 lb., while the sales exceeded 47,000,000 lb. Thus the domestic consumption of that year was in part supplied from the large stocks carried over from the previous year's abnormally high production. Nevertheless, it is satisfactory to note that progress was made in the direction of a wider range, many dyes of greater complexity and more specialised application being produced and marketed for the first time in the United States; although such materials do not make substantial additions to the bulk of production, they are essential factors in the development of a flourishing domestic industry. Further encouragement follows from the circumstance that in the year 1914 the United States imported nearly 46,000,000 lb. of dyes and produced only 6,000,000 lb., almost entirely from German intermediates. There are still requirements which have to be met from foreign sources, however, 3,914,036 lb. being imported in 1921, principally from Germany (48 per cent.) and Switzerland (41 per cent.); while this quantity exceeds by 511,454 lb. the amount imported in 1920, the average price has fallen from 1·7 dollars for that year to 1·3 dollars for 1921. Simultaneously, the price of domestic dyes has fallen from an average of 1·08 dollars per lb. in 1920 to 83 cents in 1921. From an American standpoint, the most disturbing feature of the year under review is the diminution of exports, the value of which has fallen from 29,833,591 dollars in 1920 to 6,270,139 dollars in 1921; the total exports thus fell below those of the year 1917, when the first considerable expansion of the domestic dye-manufacturing industry from pre-war dimensions was noted.

SUBJECT to the sanction of Parliament, the Ministry of Agriculture is putting forward a further scheme for the drainage of agricultural land as a measure towards the relief of unemployment, especially in rural districts. It is estimated that last winter not less than 340,000 acres were relieved of flooding or water-logging, but a far greater area is still in need of drainage. The scheme is designed for the improvement of arterial drains and watercourses, and grants cannot be made in aid of such work as tile-draining or the cleansing of field ditches. The work must in all cases be completed by March 11, 1923, as no public money will be forthcoming after March 31 next. All schemes from Drainage Authorities must be submitted to the Ministry before December 1, and from County Agricultural Committees before December 16. As the main object to be achieved is to get unemployed men rapidly to work, the Ministry does not intend to let any unnecessary formalities stand in the way of schemes that can be put into operation promptly.

THE Journal of the Royal Society of Arts for August 4 contains the three Cantor Lectures recently delivered before the Society by Mr. C. Ainsworth Mitchell, on "Inks." It is sixty-five years since a communication was made to the Society on this subject—the previous one being a paper by Mr. Underwood in 1857. The lecturer traces the use of inks as far back as 2697 B.C., the date of an old Chinese manuscript in which is described the process of making Chinese ink from lamp-black and glue. Iron gall inks are known to have been used in this country as early as the ninth century A.D. The use of indigo in blue-black ink was introduced in this country in 1836 by Stephens. Aniline dyes were certainly used in inks more than forty years ago, but their presence in the inks in entries in old family Bibles put forward as proofs that claimants for old age pensions were seventy years old, has several times been fatal to the claim. Documents alleged to date from 1719 to 1792 in support of a claim to a baronetcy were proved to be written with ink containing aniline dyes, and therefore were certainly very much more recent. The manufacture, properties, sophistication, analysis, and legal aspects of the uses of inks of various kinds were discussed by the lecturer.

WE have already referred in these columns to the formation of L'Institut d'Optique and the publication of the *Revue d'Optique* in France. These measures have been taken in order that she may manufacture all the optical instruments she requires at home, instead of importing them. The July issue of the Bulletin of the Société d'Encouragement pour l'Industrie nationale contains a report on the first two years' work of the Institut. According to this report the services of the Institut are likely to be in great demand in the near future, and the accommodation at present provided must be extended. More instruments for the practical work of students are required, and time must be allowed in the three years' course for laboratory work. It is hoped that the publication of the lecture courses will reduce the time of attendance at lectures and thus provide the additional time required in the laboratory. The researches which the optical industry requests the Institut to carry out are increasing in number and importance and show that it meets a real need.

THE fourth centenary of the first circumnavigation of the world was celebrated at Guetaria, near San Sebastian, on September 7. Guetaria was the birth-place of Juan Sebastian del Cano, who succeeded to the command of Magellan's expedition after the leader was killed in the Philippines. He returned to Spain in the *Vittoria* on September 6, 1522. An international fleet of twenty-one ships assembled in the bay to take part in the centenary celebrations, at which Great Britain was represented by Rear-Admiral W. S. Nicholson in H.M.S. *Curaçoa*. A service in the old church was followed by a pageant depicting the scenes which took place on del Cano's return.

The King of Spain laid the foundation-stone of a monument to commemorate the voyage.

AFTER a journey of some 25,000 miles and an absence of almost a year, the *Quest* has returned with the members of the Shackleton-Rowett expedition, and entered Cawsand Bay, Plymouth, on September 15. According to the *Times*, valuable hydrographical work has been carried out in the Antarctic and around South Georgia and Elephant Island, and a large-scale map of Gough Island prepared. The highest point on the latter has been named Mount Rowett. In the Enderby Quadrant a point was reached farther south than the extreme latitudes reached by Biscoe and Bellinghausen, but severe pack-ice prevented the exploration of Enderby Land. Much meteorological data were collected. A new bird of the finch species and a new tree resembling an acacia were discovered on Gough Island. The *Quest* proceeded to Portsmouth, arriving on September 18, and Commander F. Wild received a telegram of welcome from the King; referring to the loss of Sir Ernest Shackleton, the King said: "Your record of achievement and the indomitable spirit displayed by all members of the expedition were in every way worthy of his great example."

PROF. L. BAIRSTOW will deliver a lecture to the Royal Aeronautical Society (at the Royal United Service Institution) at 5.30 on Thursday, October 5, on "The Work of S. P. Langley."

THE twenty-fifth annual Traill-Taylor Memorial Lecture of the Royal Photographic Society will be delivered by Dr. R. S. Clay on Tuesday, October 10, at 8 o'clock. The subject will be, "The Development of the Photographic Lens from the Historical Point of View."

THE following courses of free public Gresham Lectures will be delivered at 6 o'clock at Gresham College, Basinghall Street, E.C.: on October 17, 18, 19, 20—Astronomy, by A. R. Hinks; on October 24, 25, 26, 27—Physic, by Sir R. Armstrong-Jones; on November 14, 15, 16, 17—Geometry, by W. H. Wagstaff.

MR. E. LEONARD GILL has been appointed by the Civil Service Commissioners to fill the vacant Assistantship in the Natural History Department of the Royal Scottish Museum, Edinburgh. Mr. Gill has already had museum experience in Leicester and Manchester, and for almost twenty years has been in charge of the Hancock Museum at Newcastle-on-Tyne.

A CONFERENCE of representatives of some twenty of the smaller engineering societies has been arranged under the auspices of the Society of Engineers, to be held on September 29 at the Engineers' Club. The object of the meeting is to consider, and if thought advisable, to inaugurate an Association of British Engineering Societies. According to the draft con-

stitution of the proposed Association, there would be no individual members, the constituent societies functioning as such; each society, however, would retain its independence. It is proposed to issue a journal or transactions in which all papers read before constituent societies would be printed and the expenses met by capitation grants from the societies concerned. Further particulars of the meeting and the proposals can be obtained from the Secretary of the Society of Engineers, 17 Victoria Street, S.W.1.

REFERRING to the obituary notice of Dr. Alexander Graham Bell in *NATURE* of August 12, p. 225, Mr. F. De Land, of the Hubbard Memorial Hall, Washington, D.C., informs us that the Boston newspapers of Monday, November 27, 1876, tell the story of transmitting speech on the previous day about 200 miles from Boston through Portland to Salem; the *Boston Post* stated that the "voice could be heard with considerable clearness after having passed over this great distance. But owing to the unfit construction of the telephones for the duty required of them a distinctness was not attained which would allow a conversation to be carried on." Mr. De Land also states that other records show that *conversation* was successfully transmitted in 1876 a distance of 143 miles. We believe, however, that in the first commercial prospectus of the telephone issued, it was stated that 20 miles was the limit at which the company would establish telephony; on account of distortion *commercial* telephony at greater distances would have been impossible with the apparatus then in use, though possibly words were transmitted 143 miles so early as 1876.

OUR knowledge of the organs and sense of smell and of odorous substances is defective, and what there is needs systematisation. Mr. J. H. Kenneth has recently published in *Osmics* (Oliver and Boyd: 2s. net) the first instalment of a bibliography of the subject of 500 items which should prove useful to any one desiring to find his way into the scattered literature. There are indexes of subjects and of species of animal.

THE Ministry of Agriculture and Fisheries has recently issued in collected form the leaflets dealing with diseases of animals and insect pests of fruit trees. The two series are now available in bound form ("Collected Leaflets on Diseases of Animals," 1s.; "Collected Leaflets on Insect Pests of Fruit Trees," 6d.). Successful treatment and prevention, whether it be of animal or plant diseases, depends upon early and accurate diagnosis: for the correct identification of the symptoms of any complaint it is necessary to have accurate information available for reference. The leaflets of the Ministry are written with this object in view as well as to supply instructions for the best treatment. The information contained in these two booklets has been brought thoroughly up-to-date, and, in many cases, new and better illustrations than those which accompanied the older leaflets have been provided.

THE reference in NATURE of September 2, p. 324, to the excellent series of wireless telephone receiving sets which are being placed on the market by the Metropolitan Vickers Co., Ltd., contains a statement which, if uncorrected, might lead to misapprehension regarding the completeness of the apparatus sent out by the company. In referring to the simplest of the sets, the remark was made that it was not clear whether the battery was contained in the case. The set in question, however, is fitted with a crystal detector, and therefore no battery is required; and, indeed, this is one of its chief advantages. In the case of the more expensive valve sets, all the necessary batteries are included with the apparatus, for the company makes a special point of the fact that every outfit is sent out complete in every respect.

### Our Astronomical Column.

MARS.—An interesting example of the somewhat unusual atmospheric conditions exhibited on Mars at this apparition is described by E. C. Slipher (Pub. Ast. Soc. Pacific, Aug. 1922). This was a large white equatorial spot situated at the south end of Margaritifer Sinus; it was about 800 miles long, 400 miles wide, and comparable with the polar caps in brilliancy, though slightly more yellowish. There was no trace of it on July 8; it was very brilliant on July 9; on July 10 it was larger but fainter, and crossed by two greyish streaks; on July 11 it had split into three separate portions, of which only one, to the right of Margaritifer Sinus, remained on July 12. On July 13 and 14 the region had resumed its normal appearance. Whitish patches are frequently seen near the limbs, but they generally disappear near the central meridian, indicating that they are morning or evening mists or hoar frosts. This great spot, on the other hand, persisted in full strength throughout the Martian day. The article is illustrated by drawings and photographs, the latter being on a small scale, but fully confirming the changes in the aspect of the spot, which was probably cloud or mist. Its appearance shows that conditions on the planet's surface are by no means so stagnant as some assert.

Prof. W. H. Pickering contributes an article on the planet to *Popular Astronomy* (Aug.-Sept. 1922). It is in reply to one by Prof. Porter, and lays stress on the broad dark band that is visible round the melting polar cap; he gives good reasons for thinking that this is water, not carbon dioxide, and concludes that the day-temperature, even near the poles, is above freezing point, while at the equator it may rise to (say) 60° F. He notes the green colour of the "Maria" after the melting of the polar caps, which he, in common with many astronomers, ascribes to some form of vegetation, another indication of a temperature above freezing point. From the frequent presence of cloud or mist near the terminator, he conjectures that the nights are generally cloudy, which would tend to mitigate the severity of the night frosts. He notes that Prof. Campbell's spectroscopic observation (quoted by Prof. Porter) did not prove the complete absence of water-vapour, but only that its amount was less than a quarter of that in the earth's atmosphere.

THE LAW OF SOLAR ROTATION.—The determination of the law of rotation of the sun is an old problem,

WE have received from Leslie McMichael, Ltd. (Providence Place, Kilburn), a catalogue of wireless telegraph and telephone apparatus covering a considerable range, and including not only complete receiving sets of various types, but also extensive lists of component parts and accessories from which amateurs and others can make up equipment to cover any requirements on a moderate scale. We notice in particular a very low-priced two-valve receiving set for short wave-lengths which should fulfil the requirements of broadcasting but can easily be converted to longer wave reception and greater sensibility when desired. Some of the apparatus listed has been purchased from the Disposals Board and is offered at favourable prices, and a few items are marked German captured material, transformed as new. A quantity of accessories for transmitting as well as receiving apparatus is included.

first formulated by Carrington, who studied the motions of spots as they moved across the solar disc. As sunspots are confined to middle and low latitudes, the law, based on actual data, was restricted to these latitudes. The spectroscopic method of determination was a great step in advance, because a law could be deduced which could be extended to the solar poles. Spectroscopists have, until recently, been somewhat in difficulty with their results, for determinations at different times by different observers have resulted in formulae which did not agree. The fact is that a law formulated from observations made at, say, sunspot minimum is not applicable at a sunspot maximum, because the movements of the vapours in the solar atmosphere vary from year to year. This question of the variability of the sun's rotation during a cycle of solar activity was raised last year by Prof. Newall (Mon. Not. R.A.S., vol. 82, p. 101), and in the current number of the same publication (vol. 82, p. 479) Dr. Halm now clearly shows that "the same law of rotation of the reversing layer can be expected only under similar conditions of activity." He shows a very impressive series of curves, illustrating the angular velocities for about every ten degrees of solar latitude for each year from 1901 to 1914, excluding 1910. In these the angular velocity increases rapidly from sunspot minimum (1901) to sunspot maximum (1905), and then more slowly decreases to sunspot minimum (1913); the amplitude being much more pronounced for high than for low heliographic latitudes. These results are based on observations made at Upsala, Edinburgh, Mount Wilson, and Ottawa.

SUNSPOT IN HIGH LATITUDE.—A small sunspot was noted at Mt. Wilson on June 24 in latitude 31° north, longitude 8° east. No spot has been seen in such a high latitude since December 1919, and it is considered to be the first spot of the new cycle. It will be remembered that the equatorial spots of the expiring cycle continue for a year or more after the commencement of the new one, so that the actual minimum may not be reached till next year. The above spot was of negative polarity, whereas most of the single northern spots in the expiring cycle were positive. This is a further argument, though not a decisive one, for the spot belonging to the new cycle.

## Research Items.

**THE DATE OF STONEHENGE.**—In the September issue of *Man* Rear-Admiral Boyle T. Somerville discusses a previous article in that journal by Mr. Stone on the date assigned by Sir Norman Lockyer, through astronomical means, for the building of Stonehenge. He points out in detail the limitations which surround the dating of prehistoric monuments by means of bearings of sunrise or sunset. There are also at Stonehenge two circles, one apparently considerably more ancient than the other. Neither of these stands on the arc of a true circle, and consequently it is not possible to discover the accurate centre, nor any given diameter of either of them. The remains of the earthwork vallum do not lie on parallel lines, nor does either wall appear to be straight. A difference of date of 1000 years is effected by the movement of the observer of only one foot to left or to right of what may originally have been the true point of observation within the circle. The result is that the attempt to date either of the circles at Stonehenge by the azimuth of the midsummer sunrise is useless, as the present condition of ruin of the monument is too great to lay out from the ground-plan of either circle an orientation line of sufficient accuracy. If the orientation towards Silbury Hill can be considered a probability, as it was by Sir Norman Lockyer, the limits of date given by him, namely 2000 years on either side of 1680 B.C., are justified for whichever circle to which it related.

**ARAB ART IN AMERICA.**—The University Museum, Philadelphia, is in the fortunate position of being able to spend largely on additions to its collections. In the March issue of its *Museum Journal*, Mr. G. B. Gordon describes some examples of Arab art which have recently been acquired. Two mosaic fountains of fifteenth-century work are charming, and are appropriately placed in a room decorated with a wonderful wooden door with carved ivory inlay from fourteenth-century Cairo. The ornamentation of this door is singularly beautiful, the style combining small pieces dove-tailed together, the result of the scarcity of large blocks of suitable wood in Egypt. There are also some examples of Rhodian, Damascus, and Samarkand tiles, which are finely reproduced in colour to illustrate the article. Mr. Gordon gives some useful notes on the development of Arab art, especially in connexion with the taboo of human and animal forms prescribed in Islam. At Fostat, near Cairo, a rubbish heap in the town, abandoned in the thirteenth century for the present capital, has yielded some curious fragments of early Arab pottery, of which examples are also reproduced in colour.

**ORIGIN OF ANIMAL PIGMENTS.**—That animals in general are, directly or indirectly, dependent upon green plants for their supplies of energy is one of the most widely recognised generalisations of biological science. The importance of chlorophyll in the animal economy, however, seems to be by no means limited to the problem of food-supply. It is extremely doubtful whether chlorophyll is ever actually formed by the animal body itself, but it is very extensively taken in with vegetable food, and then apparently forms the basis from which a large number of animal pigments are built up, including the widely distributed respiratory pigment, hæmoglobin. Such, at any rate, is the finding of Mr. John F. Fulton, Jr., who contributes an interesting paper on "Animal Chlorophyll: its Relation to Hæmoglobin and to other Animal Pigments" to the current number of the

*Quarterly Journal of Microscopical Science* (vol. 66, Pt. II.). It would appear from these results that a vast number of animals are dependent upon green plants for their ability to carry on the function of respiration as well as that of nutrition.

**SOURCES OF VITAMIN A.**—In the *Biochemical Journal* (vol. xvi., No. 4) a paper appears under the names of H. L. Jameson, J. C. Drummond, and K. H. Coward, giving an account of the work in which Dr. Jameson was engaged at the time of his death. Previous work by the other two authors had shown that vitamin A is produced in green plants by the action of light. Animals are apparently unable to make it for themselves, and since the liver of fishes is one of the best sources of this vitamin, it was of interest to follow the course of its transfer to this place. In the present paper it is shown that a pure culture of the diatom *Nitzschia* produces the vitamin under the action of light. Various molluscs were also found to contain it in considerable amounts. In a further paper in the same number of the journal, Prof. Drummond, Dr. Zilva, and Miss Coward show that the small organisms of animal nature making up the plankton on which small fish feed contain vitamin A in abundance, no doubt derived from the diatoms on which the plankton feed. Thus the cycle in marine life is complete. Whether this vitamin is identical with that preventing the onset of rickets is made somewhat doubtful by a paper in the *Journal of Biological Chemistry*, vol. 53, p. 293, by McCollum, Simmonds, Becker, and Shipley, in which it is shown that the vitamin A of cod-liver oil can be destroyed without depriving the oil of the substance which causes utilisation of calcium and its deposition in the bones. It may be that it is this "vitamin" that is produced in the human infant under the action of light.

**ANOMALOUS STORM TRACKS.**—A communication is made on this subject to the *U.S. Monthly Weather Review* for March by Mr. E. H. Bowie of the U.S. Weather Bureau. The author criticises the explanation of the paths of cyclones given in the text-books, and remarks that it would simplify the work of forecasters if cyclones behaved in an orderly manner. The paths are shown of five exceptionally erratic cyclones, and especial care has been taken to ensure the accuracy of the charted positions of the storm centres. The erratic paths given traverse the eastern United States; one storm was of West Indian origin. Each of the tracks formed one or more loops, and in forming the loop the turning in all cases was counter-clockwise. Some notes on the erratic paths of the storms are added by Prof. A. J. Henry, chiefly with the object of stimulating discussion. He notes that the temporary blocking in the path of the cyclone takes place in the neighbourhood of water surface, and in each case of temporary blocking, except in that of the West Indian storm, pressure rose over the Canadian Maritime Provinces.

**CLIMATE AND PHOTOGRAPHY.**—An article by Mr. H. G. Cornthwaite on this subject appears in the *U.S. Monthly Weather Review* for March. The wide variations in the strength of daylight with the time of day, season of the year, conditions of the sky, and with latitude and altitude, as well as the effects of temperature and humidity on photographic and chemical processes, are recognised and discussed. The actinic light is naturally brightest when the sun

is at or near the zenith, and it dims rapidly with increased obliquity of its rays. The seasonal variation due to this cause is said to be too often overlooked or underestimated by amateur photographers, the strength of the light being about twice as great in summer as in late autumn or winter. It is mentioned that during heavy rainfall the light is photographically stronger than in densely cloudy weather without rain, due to the light reflected from the falling raindrops. Tropical daylight is asserted to be about twice as strong photographically as summer daylight in latitude  $40^\circ$ , and about four times as bright as winter daylight at this latitude. The light is much brighter along the sea coast than inland. Chemical activity in developing and fixing processes is greatly increased with high temperatures, and correspondingly retarded with low temperatures. Photographic films and prints may be subjected either to high temperatures or high humidity without excessive deterioration, but not to both in combination. Both prints and films are said to deteriorate rapidly in the moist tropics, but those developed and fixed under tropical conditions have a greater permanence in the tropics than those developed and printed in the temperate zone and subsequently taken to the tropics.

#### ELECTRICAL RESISTIVITY OF STEELS UNDER STRESS.

—The recent researches of Bridgman have shown that under hydrostatic pressure the resistivity of steels decreases, while the earlier work of Tomlinson on stretched steel wires showed that under tension less than the elastic limit the resistivity increased. According to the May issue of the Science Reports of Sendai University, Mr. Sin-iti Fukuta has, under the direction of Prof. Honda, carried out the observation of the effect of tension on resistivity beyond the elastic limit, and has succeeded in showing that up to stresses of the order of 5000 kilograms per sq. cm., steels with various carbon contents increase in resistivity  $1.14 \times 10^{-6}$  per cent. per kilogram per sq. cm. of tensile stress, the proportionality continuing past the shoulder of the stress-strain curve. In all cases about 90 per cent. of the observed change of resistance of the specimen was due to its elongation and cross contraction.

GLASS RESEARCH.—Volume iv. of "Experimental Researches and Reports" has recently been published by the Glass Technology Department of the University of Sheffield. It comprises a series of reports by Dr. W. E. S. Turner and his staff, principally on the influence of aluminium on sodium and sodium calcium trisilicate glasses. Aluminium is shown in the first paper, No. VII., to facilitate manipulation in lamp-working and to assist in preventing devitrification. The second paper on the effect of aluminium on the annealing temperature is less convincing, as it neglects questions of time and rates of cooling. Pelouze's conclusion that as aluminium is substituted for sodium the density increases, is reversed in paper IX.; density and refraction both appear to diminish. Careful stirring has evidently been necessary to detect the small variations recorded. In determining the thermal expansion effect of silica and sodium oxide in sodium silicate glasses, a silica factor value very different from that of Schott has been obtained. In the next paper, No. XV., the effect of aluminium on thermal expansion is considered, but further research is evidently required. Two of the most practical papers deal with the relative advantages and disadvantages of limestone, burnt lime, and slaked lime in common glass batches containing soda ash and salt cake. The shrinkage, porosity, and other properties of British fireclays are discussed in paper XXIII.

Comparison is made with one foreign clay only, the German Grossalmerode. In view of the present conditions it might have been well to include several of the French clays which compare favourably with Grossalmerode. Following two papers on lime-magnesia glasses, a general report on glass and one on the refractory materials, both by Dr. Turner, are reprinted. The glass industry is to be congratulated upon its close association with the University of Sheffield and the Society of Glass Technology.

PHOTOGRAPHIC SENSITOMETRY AND TESTING.—The Washington Government Printing Office has issued No. 439 of the Scientific Papers of the Bureau of Standards on the "Sensitometry of Photographic Emulsions and a Survey of the Characteristics of Plates and Films of American Manufacture," by Raymond Davis and F. M. Walters, jun. For several years the Bureau of Standards has made measurements of the characteristics of photographic light-sensitive materials, aiming at uniformity in the standardisation of methods, so that the results by various workers may be directly comparable. The present paper gives details of the principles involved in photographic sensitometry and testing generally as introduced by Hurter and Driffell and published over and over again during the last thirty years. Perhaps it is desirable to restate them to render the paper more complete. The methods of the Bureau are more original. Their light source is a 6 to 8 volt Mazda C automobile headlight with a special blue glass filter, giving 2.73 candle-power and the colour of average yearly noon sunlight at the latitude of Washington. The principal other deviation from H. and D. methods is that the Bureau of Standards defines the speed of a plate as 10 divided by the inertia, instead of 34 divided by the inertia as adopted by Hurter and Driffell to fit in with their actinometer. For colour sensitometry a replica grating is used with a slit 2 inches long, and the exposure is graduated by a disc with suitably curved apertures that is rotated close in front of the slit. The methods of making other tests are fully described. Appended are 86 charts, each dealing with a single plate and giving three characteristic curves representing the result of development for 3, 6, and 12 minutes respectively, a contrast development curve, a fog contrast curve, the fog being exclusive of the glass and gelatine, a spectrogram showing colour sensitiveness, exposure factors for several colour filters, speed, extent of the straight part of the characteristic curve, and the resolving power estimated by a standardised method. Only sensitive materials made in the United States, and practically all of these, are discussed.

SEPARATION OF ISOTOPES OF LEAD.—In the Scientific Proceedings of the Royal Dublin Society for August (vol. xvii. N.S. No. 6), Drs. T. Dillon and R. Clarke and Mr. V. M. Hinchey describe some preliminary experiments on the separation of the isotopes of lead by a chemical method. The process is based on the reaction between lead chloride and an organo-magnesium compound:



Hoffmann and Wolf in 1907 had already found that when lead chloride containing radium-D reacted with magnesium phenyl bromide, most of the radioactivity was found in the metallic lead separated by the above reaction, and this was confirmed. With the two portions of lead separated, the atomic weights 207.1 and 207.3 or 207.4 were found, and it is considered that the different isotopes of lead are not identical in their chemical properties in the reaction chosen. Further experiments are in progress.

## Potato Trials at Ormskirk.

SIR DANIEL HALL, Chief Scientific Adviser of the Ministry of Agriculture, presided at the public inspection at Ormskirk on August 24 of the eighth series of annual trials of new potato varieties for immunity from Wart Disease (*Synchytrium endobioticum*). In addressing the important gathering of growers and scientific workers, Sir Daniel expressed the view that the disease must inevitably spread over the whole of Great Britain. The only known protection against the disease is to plant varieties which are immune from its attacks; unfortunately the most popular of the varieties at present grown are not immune. The production of new immune varieties with good cropping, cooking, and keeping qualities is therefore essential, and it was with the view of enabling raisers to ascertain whether their new productions would resist the disease that these trials were begun in 1915. In that year 94 stocks were sent for test; the trials have been largely developed by the Ministry of Agriculture, and since 1920 have been carried out at the Potato Testing Station of the National Institute of Agricultural Botany. This season 2500 stocks were planted. In an attempt to keep the spread of the disease within bounds the Ministry issues annually a list of new varieties which have proved immune in the trials. Only listed varieties may be planted in infected soil, or sent away from infected areas for seed purposes. Before a variety is regarded as immune it must have been grown at Ormskirk for two consecutive seasons without succumbing. Supplementary one-year trials of small stocks (not exceeding ten tubers) of seedlings are conducted for the information

of raisers, but these trials are not taken into account by the Ministry in drawing up the list of immunes.

It is apparent from the results of the last two seasons that the rainfall affects the incidence of the disease. In the dry summer of 1921 the disease appeared very late, and its attacks were less severe; this season, with much rain, the disease has appeared earlier and is very marked. Of the 91 new stocks that are being tested for the second season, 19 have so far succumbed, though they escaped last year.

There are 123 stocks under trial for the first time this season: 58 have already succumbed and 48 cannot be distinguished from previously existing varieties. The number of varieties entered as new but in fact identical with older varieties is, however, much smaller than in previous years owing to the activities of the Synonym Committee of the National Institute of Agricultural Botany. The one-year seedling trials occupy 1700 of the 2500 plots, and 500 are planted with stocks of established varieties for demonstration purposes.

The Institute is also conducting, for the second year, trials to establish the relative dates of maturity of nine important first early varieties, and the influence of source of seed on date of maturity and yield. The trials are composed of three chequer boards, one consisting of all 9 stocks drawn from 8 different districts, one of all 9 stocks from one district, and the third of one stock drawn from all 8 districts. The results should also be of value in indicating the most accurate method for conducting yield trials.

## International Reunion of Chemists at Utrecht.

ON June 21, 22, and 23 there was held at Utrecht an international reunion of chemists, which was organised by Profs. Ernst Cohen, H. R. Kruyt, and P. van Romburgh, of the University of Utrecht. Among those also present may be mentioned:—Abel (Vienna), Backer (Groningen), Baly (Liverpool), Billiter (Vienna), Bjerrum (Copenhagen), Bodenstein (Hanover), Blanksma (Leiden), Bredig (Carlsruhe), Brönsted (Copenhagen), Centnerschwer (Riga), Dennis (Ithaca, N.Y.), Donnan (London), Dubsy (Brünn), Emich (Graz), Hahn (Berlin-Dahlem), Holleman (Amsterdam), MacInnes (Cambridge, Massachusetts), Jaeger (Groningen), Jorissen (Leiden), Kailan (Vienna), Klemenc (Vienna), Lewis (Liverpool), Noyes (Urbana, Illinois), Petersen (Copenhagen), Pfeiffer (Bonn), Piccard (Lausanne), Pregl (Graz), Reinders (Delft), Schenck (Münster), Schilow (Moscow), Schlenk (Berlin), Simek (Brünn), Skrabal (Graz), Stock (Berlin-Dahlem), Walden (Rostock), Wegscheider (Vienna), Wieland (Freiburg in Breisgau), and Winther (Copenhagen).

During the scientific meetings a number of very interesting papers were read, which gave rise to good discussions. Among these may be mentioned the following: photochemical catalysis (Baly); the photochemical combination of hydrogen and chlorine (Bodenstein); free radicals (Walden); contributions to the chemistry of the free radicals and the variable affinity-value of the carbon linking (Schlenk); free radicals (Wieland); positive and negative valence (Noyes); the preparation and properties of metallic

germanium (Dennis); absorption colours of the second order (Piccard); and adsorption and distribution (Schilow).

The chemists attending the meeting received the heartiest of welcomes and the most lavish hospitality from their Dutch colleagues, who arranged a series of lunches, dinners, and excursions. Few of those who were present will ever forget the splendid hospitality of Holland, the excellence of the arrangements, and the atmosphere of good fellowship which characterised the meeting.

On the afternoon of the second day a reception was given by the Dutch Chemical Association, while on the afternoon of the last day the members were invited to tea by Count Dr. van Lynden van Sandenburg, Governor of the Province of Utrecht, and Countess van Lynden van Sandenburg. The meeting concluded with a banquet at the Badhotel, Baarn, which was preceded by a visit to the beautiful Botanic Gardens of the University of Utrecht.

The heartiest thanks of all the chemists who attended the meeting are due to Prof. Ernst Cohen, who acted as a most genial and efficient president, to his collaborators, and to all those in Holland who subscribed so liberally towards the expenses of the reunion. It was felt by all present that Holland had done in the most graceful way a noble piece of work towards the promotion and restoration of that international friendship of science which is of such vital importance for the world.

F. G. D.

## Summary of the Theory of Relativity.

By Prof. H. T. H. PRAGGIO, University College, Nottingham.

I. BREAKDOWN OF OLDER THEORIES.—The older electromagnetic theory of moving bodies did not agree with experiment, or even with itself. For example, the theory of a magnet moving in a straight line towards a fixed conductor gave results quite different from those of the theory of a conductor moving in a straight line with the same velocity towards a fixed magnet. Yet experiment showed that the results should be the same, depending only on the relative velocity. Again, the æther was assumed to be at the same time quite unaffected by the earth's motion (to explain aberration), partly affected (to explain Fizeau's water-tube experiment), and entirely affected (to explain the experiments of Michelson and Morley, Lodge, Rowland, Rayleigh and Brace, Trouton and Noble, and others).

II. FUNDAMENTAL ASSUMPTIONS OF EINSTEIN'S RESTRICTED THEORY (1905).—This takes over Maxwell's theory so far as it applies to bodies at rest relative to the earth and deals with other systems by the two following assumptions:

(1) All electro-dynamical and optical equations which hold for a system S hold also for another system S' which, relative to S, moves with uniform velocity  $v$  in a straight line.

(2) Light is propagated in a vacuum with a velocity  $c$  which appears the same for observers in S and S'.

*Kinematical deductions from these assumptions.*—These imply that the measures of time and space in S and S' must be such that

$$x^2 + y^2 + z^2 - c^2t^2 = x'^2 + y'^2 + z'^2 - c^2t'^2,$$

from which, taking the corresponding axes in each system to be parallel and the relative velocity to be along Ox (or Ox'), we can prove that

$$x' = \beta(x - vt), \quad y' = y, \quad z' = z, \quad t' = \beta\left(t - \frac{vx}{c^2}\right)$$

where  $\beta = \left(1 - \frac{v^2}{c^2}\right)^{-\frac{1}{2}}$ . (A);

hence two observers, one in S and one in S', will each imagine

- (i.) that a rod along Ox (or Ox') in the other's system has contracted in the ratio  $\beta : 1$ ;
- (ii.) that the other's clocks (supposed controlled by light signals) lose, taking  $\beta$  seconds instead of 1 for a beat;
- (iii.) that the events which the other takes as simultaneous are not so.

What they will agree about is the velocity of light,  $c$ , their own relative speed, and the interval between two sets of values,  $x, y, z, t$ , for two events, this interval being defined as

$$\sqrt{(c^2(t_2 - t_1)^2 - (x_2 - x_1)^2 - (y_2 - y_1)^2 - (z_2 - z_1)^2)},$$

which may be written,

$$\sqrt{c^2 dt^2 - dx^2 - dy^2 - dz^2}.$$

It is generally denoted by  $ds$ .

From equations (A)  $\frac{dx'}{dt'} = \frac{dx}{dt} - v$  so that if the

$$\frac{dx'}{dt'} = \frac{dx}{dt} - v \quad \text{so that if the}$$

velocity of the body moving along Ox' (or Ox) is V in the system S and V' in the system S'

$$V' = \frac{V - v}{1 - \frac{vV}{c^2}}, \quad \text{or } V = \frac{V' + v}{1 + \frac{vV'}{c^2}}.$$

This is confirmed by Fizeau's water-tube experiment, and (it is claimed) by Majorana's moving mirror experiment. From this formula we see that

by combining two velocities  $V'$  and  $v$ , each of which is smaller than  $c$ , we obtain a velocity  $V$  which is always smaller than  $c$ . (The statement that "no velocity can exceed  $c$ " is too sweeping; the velocity of light in a thin metal prism exceeds  $c$ .)

*Electrodynamical deductions from these assumptions.*—Transforming Maxwell's equations for free space in which electrons move with velocity  $V$  along Ox we get from assumption (1) and equations (A) that

$$\left. \begin{aligned} E'_x &= E_x, & H'_x &= H_x \\ E'_y - \beta\left(E_y - \frac{v}{c}H_z\right), & H'_y &= \beta\left(H_y + \frac{v}{c}E_z\right) \\ E'_z - \beta\left(E_z + \frac{v}{c}H_y\right), & H'_z &= \beta\left(H_z - \frac{v}{c}E_y\right) \end{aligned} \right\} \quad (B).$$

$$\rho' = \beta\rho\left(1 - \frac{vV}{c^2}\right).$$

The expression for  $\rho'$  gives the remarkable result that the charge on an electron appears the same in both systems. From these we can deduce:

- (i.) Doppler's effect in the modified form—

$$f' = f \left( \frac{1 - \frac{v}{c}}{1 + \frac{v}{c}} \right)^{\frac{1}{2}}, \quad \text{where } v \text{ is the relative velocity}$$

- in the line of sight,  $f$  and  $f'$  the frequencies;
- (ii.) a modified law of aberration;
  - (iii.) the force exerted by light on a moving mirror;
  - (iv.) the electric and magnetic fields due to a uniformly moving electron.

The differences between these forms and those given by older theories are too small to be detected by experiment.

*Dynamics of an electron (slowly accelerated).*—With the additional assumption that every electron has a constant  $m$  associated with it, such that force =  $m \times$  acceleration at the instant when the electron is at rest in the system of co-ordinates used (and only at that instant), we deduce that in any other system the equations of motion are

$$\left. \begin{aligned} m\beta^3 \frac{d^2x}{dt^2} &= eE_x, \\ m\beta \frac{d^2y}{dt^2} &= e\left(E_y - \frac{v}{c}H_z\right), \\ m\beta \frac{d^2z}{dt^2} &= e\left(E_z + \frac{v}{c}H_y\right), \end{aligned} \right\} \quad \text{where } e \text{ is the charge on the electron and the axis of } x \text{ is taken in the direction of its velocity } v. \text{ The second and third of these equations are confirmed by Bucherer's experiments.}$$

If, with Lorentz, we take the right-hand sides as the components of the force, and retain the old law force = mass  $\times$  acceleration, we find it necessary to speak of a longitudinal mass  $m\beta^3$  and a transverse mass  $m\beta$ .

But we may rewrite the left-hand sides in the symmetrical form  $\frac{d}{dt}(m\beta^3 \frac{dx}{dt})$ ,  $\frac{d}{dt}(m\beta \frac{dy}{dt})$ , and  $\frac{d}{dt}(m\beta \frac{dz}{dt})$ .

This suggests the definitions:

- mass (M) = mass at low speeds  $\times \beta$  (both for longitudinal and transverse mass);  
momentum = mass  $\times$  velocity;  
force = rate of change of momentum.

Defining work in the usual way from force and displacement, we can further deduce:

Work done on an electron = increase of its kinetic energy, provided that kinetic energy is defined as  $Mc^2 + a$  constant =  $m\beta^3 c^2 + a$  constant.

If we take the constant equal to  $-mc^2$ , this new definition reduces to  $\frac{1}{2}mv^2$  approximately for small values of  $v/c$ . From Maxwell's equations we can derive four relations for an isolated system of electrons which



may be interpreted as the conservation of momentum and of energy, provided that the momentum and energy of the electrons are defined as above, and that the momentum and energy of the field are included, the momentum of the field per unit volume being defined as  $\Pi/c^2$ , where  $\Pi$  is Poynting's vector. Observations on the spectral lines of hydrogen, and Guye and Lavanchy's experiments on cathode rays, confirm these results.

III. FUNDAMENTAL ASSUMPTIONS OF EINSTEIN'S GENERALISED THEORY (1915).—(1) For an infinitely small region of space and time, axes may be chosen so that the restricted theory is true in that region. This implies that for two events there exists a certain absolute quantity, the interval  $ds$ , which, by a suitable choice of co-ordinates, may be expressed as before, but which in a general system of co-ordinates,  $x_1, x_2, x_3, x_4$  (these being arbitrary functions of  $x, y, z, t$ ), take the form  $\sqrt{(\sum g_{rs} dx_r dx_s)}$ , where  $r$  and  $s$  take all values from 1 to 4, and the  $g$ 's are functions of  $x_1, x_2, x_3, x_4$ .

(2) All physical laws must be expressible by means of equations which are valid for all co-ordinate systems. That is to say, the equations are covariant, or unaltered in form, for the most general transformation (not necessarily linear). Newton's law of gravitation and all other laws that do not satisfy this condition are to be modified so as to conform with it.

(3) *The Principle of Equivalence*.—A gravitational field of force at a point or infinitely small region is exactly equivalent to a field of force introduced by a transformation of the co-ordinates of reference, so that by no possible experiment can we distinguish between them. (Eddington pointed out that the assumption is made for phenomena which depend on the  $g$ 's and their first differential coefficients, and in general it will not apply to those involving second differential coefficients.)

(4) The path of a particle in a gravitational field is such that  $\delta/ds = 0$ . (For the case when there is no gravitation this reduces to Newton's first law of motion.) This assumption reduces particle dynamics to something like the geometry of geodesics on surfaces, except that we have four independent variables instead of two.

(5) Although the coefficients in the expression for  $ds^2$  are capable of infinitely many forms, according to the system of co-ordinates used (just as in measurements on a surface the square of the shortest distance on the surface between two points can be similarly expressed in many forms corresponding to the choice of the independent variables), yet these  $g$ 's are not quite arbitrary functions of the co-ordinates, but satisfy a set of partial differential equations (analogous to those which for a surface express intrinsic properties of that surface). These differential equations are assumed to be of a certain particular form, known as those expressing the vanishing of the contracted Riemann-Christoffel tensor. (A tensor may roughly be defined as a generalised vector. If all its components vanish in one system of co-ordinates, they all vanish in any other system.) This assumption is not quite as arbitrary as it looks, for it is the second simplest set which is of the covariant form required by assumption (2). The simplest set of all corresponds to the absence of any gravitational field.

(6) The energy of a gravitational field exerts gravitating action just like ordinary masses. This assumption leads to equations which may be interpreted as implying the conservation of momentum and energy, including contributions due to the gravitational field (and to the electromagnetic if present).

*Mathematical Deductions from these Assumptions.*—

(a) *Formulae for the Interval*.—By solving the differential equations the  $g$ 's may be obtained. The

number of solutions is infinite. For a single heavy mass, choosing the units so that  $c$  and the gravitational constant are unity,

Schwarzschild gave

$$ds^2 = \left(1 - \frac{2m}{r}\right) dt^2 - \left(1 - \frac{2m}{r}\right)^{-1} dr^2 - r^2 d\theta^2 - r^2 \sin^2\theta d\phi^2.$$

F. W. Hill and G. B. Jeffery gave

$$ds^2 = \left(1 - \frac{m}{2r}\right)^2 dt^2 - \left(1 + \frac{m}{2r}\right)^4 (dr^2 + r^2 d\theta^2 + r^2 \sin^2\theta d\phi^2).$$

and Painlevé has given a great variety.

(b) *Perihelion of Mercury*.—From any of these forms and assumption (4) we can by the Calculus of Variations determine the orbit of a planet. The orbits so deduced differ very little from those calculated on the Newtonian laws. The only difference big enough to be observed is that for Mercury. Leverrier estimated that the older theory differed from observation by about  $43''$  per hundred years. Einstein's theory accounts for these  $43''$ . (But Grossmann (1922) has recalculated the old discrepancy as  $38''$ , not  $43''$ .)

(c) *Deflection of Ray of Light by Sun's Gravitational Field*.—The rays should be slightly curved, as if the gravitational field round the sun were a converging lens, thus making stars on opposite sides of the sun appear farther apart than when the sun is in another part of the sky. The result of the measurements made during the solar eclipse of May 29, 1919, agreed very closely with Einstein's predictions. This is strong evidence in support of Einstein's modification of the Newtonian law, as on the old law the deflection should be only half the amount predicted by Einstein and actually observed.

(d) *Spectral Shift*.—Einstein believes that the formula for  $ds^2$  implies that the spectral lines in the light coming to us from the surfaces of big stars should appear shifted towards the red end of the spectrum. Eddington and others think it possible that this argument may be founded on an assumption which may be rejected while the rest of the relativity theory is retained. Grebe and Bachem (Bonn) claim to have observed the predicted effect, and so do Perot and Buisson and Fabry; St. John claims to have shown that it does not occur, but his results have been doubted. The experimental difficulties are enormous.

(e) *Apparent Contraction of a Rod placed radially in a Gravitational Field*.—Einstein deduces this from the formula for  $ds^2$  and also deduces that there is no such tangential effect. Painlevé (1921) strongly objects to these deductions and points out that by taking other forms of  $ds^2$  we can reject these conclusions, while retaining all the verifiable results of the theory. If Einstein's views are correct, Euclidean geometry (e.g. Pythagoras's theorem) is not exactly true for measurements made in a gravitational field. It will be replaced by Riemann's geometry.

IV. EINSTEIN'S COSMOLOGICAL THEORY (1917).—The leading feature of this is that our universe, as measured by material rods or light rays, is finite, so that a ray of light will never get more than a certain distance from its starting-point. However, he is willing to admit that other universes may exist outside this limit, but such that their light can never meet ours. Eddington and others regard this theory rather unfavourably.

V. EINSTEIN'S VIEWS ON THE ÆTHER (1920).—Space is endowed with physical qualities. In this sense, therefore, there exists an "æther." Without it there would be no propagation of light. But this

æther may not be thought of as endowed with the physical properties of material media. It must not be considered as either fixed or moving. No explicit use of any conception of the æther is made in the theory of relativity. It is difficult to see what use could be made of the above views, which are chiefly negative. The phenomena of the gyroscope and Foucault's pendulum (and Sagnac's optical experiment), which on the Newtonian ideas are attributed to absolute space, are attributed by relativists to the æther or the effects of the fixed stars—which is rather unconvincing.

VI. WEYL'S EXTENDED THEORY (1918).—Whereas Einstein's interval depends only upon gravitational phenomena (although Maxwell's equations and all electromagnetic effects fit into the framework thus constructed), Weyl assumes that the length of the measuring rod depends upon the route it has taken in the neighbourhood of electromagnetic fields. When these are present, the interval is no longer a definite quantity (thus weakening the argument for the

spectral shift). This theory accounts for Maxwell's equations and introduces Einstein's cosmological term in a natural way, and adds the law of conservation of electricity to those of conservation of momentum and energy. On the other hand, it introduces great complexity into geometry and appears to imply the impossibility of metrology, beyond a certain—very high—degree of accuracy. There is no experimental confirmation. Einstein does not accept it. Eddington (1921) has generalised Weyl's mathematics, but says, "Einstein's postulates and deductions are exact. The natural geometry of the world . . . is the geometry of Riemann and Einstein, not Weyl's generalised geometry or mine."

VII. PAINLEVÉ'S SEMI-EINSTEINIAN THEORY OF GRAVITATION (1922).—This retains Euclidean geometry and the old ideas about space and time. By axioms which are somewhat similar to those of Einstein, but which make no reference to the restricted theory, Schwarzschild's form of  $ds^2$  and the verified astronomical results are obtained.

### Kitchen Ranges.

THERE is probably no more difficult problem presented to the heating engineer than the kitchen range. So complicated is it that it would appear that no single appliance could possibly be constructed to suit every house or even any large number of houses, and that each installation would have to be adapted to the requirements of the special household. For example, a working-man's cottage usually requires only one fire, which, in the absence of a gas cooker, must satisfy the quadruple duty of heating the room, the oven, the hot-plate and the water, whereas a better class of house might use, and with greater economy, a gas cooker and a coke boiler for the supply of hot water and radiators. Then, again, in an ordinary household, cooking is an operation occupying two or three hours per day only, while hot water is likely to be required at any moment throughout the day. Heating of the rooms is required continuously all day in winter, but not at all in summer. The inevitable consequence of such an intermittent demand is a low efficiency.

We have before us two important pamphlets embodying the researches of Dr. Margaret Fishenden and Mr. A. H. Barker carried out under the auspices of the Fuel Research Board.<sup>1</sup> Dr. Fishenden has restricted her investigation to the comparative efficiency of ranges fired with ordinary bituminous coal and those heated with the special coke cakes (low temperature coke) produced by the Fuel Research Station at E. Greenwich. She finds that low temperature coke yields a greater proportion of total heat for radiation or for water heating than bituminous coal, while for oven heating the coke compares less favourably with coal, the advantage of coke being largely due to radiation effects. She finds, moreover, that in an open kitchen range with back boiler about 17 per cent. of the heat of the coal is used for hot water, and in modern designs it varied from 13 to 19 per cent., a result rather higher than that found by Mr. Barker.

It is unfortunate that Dr. Fishenden's experiments do not include ordinary coke, as the low temperature coke prepared by the Fuel Research Board is a commodity not yet on the market and unlikely to

appear there, as it is obviously too costly to compete at present with either coal or coke. The report of Mr. Barker (who is lecturer on heating and ventilating engineering at University College, London) deals in a very comprehensive fashion with the whole subject of kitchen ranges, and the results of a large number of practical tests on old and new designs using coal, coke, and gas as sources of fuel. The introduction to the report contains the following statement: "In the design of British cooking ranges, attention has hitherto been mainly devoted to securing cheapness of construction and convenience of use. Economy in fuel consumption has only played a minor part in determining the different types in use. The shortage and high price of coal have, however, emphasized the necessity for fuel economy and, consequently, of an examination of the efficiency of British kitchen ranges. . . . The strong prejudice in favour of an open-fronted fire appears to be peculiar to this country. In most other countries a cooking range fire is usually closed. . . . In view, therefore, of the scarcity and high price of coal at the present time, it appears to be a matter for serious consideration whether steps should not be taken to encourage the more general adoption in this country of ranges which are more economical in fuel consumption than those of ordinary British design."

In his general summary Mr. Barker has arrived at the following conclusions: that the general efficiency of all ranges on the market at the present time is low, the actual oven efficiency ranging from 0.75 to 5 per cent., the usual being about 2 per cent., that of the hot water supply from 7 to 17 per cent., or usually 11 per cent., and the hot plate from 1 to 12 per cent., or generally below 6 per cent. He estimates that the modern type of range wastes 85 per cent. of the fuel in heating the air of the kitchen (about 30 per cent.), by absorption in the brickwork (about 30 per cent.), and lost in the flue gases (about 25 per cent.). Economy may be effected by not setting ranges in brickwork, by preventing leakage of cold air into the furnace and flues, and by doing away with the hot-plate or covering it when not in use, and also the oven door, with non-conducting material. He admits, however, that these losses are unavoidable if the present convenience and cheapness of the ordinary range are to be retained and one fire made to serve so many different purposes. But if the efficiency is considered irrespective of convenience, cheapness,

<sup>1</sup> (1) The Efficiency of Low Temperature Coke in Domestic Appliances, by Dr. Margaret W. Fishenden. Fuel Research Board, Technical Paper No. 5. London: H.M. Stationery Office, 1922. 9d. net.

(2) Tests on Ranges and Cooking Appliances, by A. H. Barker. Fuel Research Board, Special Report No. 4. London: H.M. Stationery Office, 1922. 2s. 6d. net.

and space, then it would be necessary to have separate fires for oven, hot water, and hot-plate. This is obviously impracticable; but, on the other hand, in a well-insulated oven heated over a small fire without excess of air by leakage, an efficiency of 30 per cent. might easily be achieved, and, he adds, "there is no reason why a whole dinner could not be cooked in such an oven with 2 lbs. of fuel." But beyond 40 or 50 per cent. efficiency in the oven it is impossible to go, and the ideal conditions can be attained only by electrical heating.

The adoption of an independent boiler would raise the efficiency of the fuel for the hot water supply from an average of 8 to 10 per cent. to 40 to 45 per cent., a figure which Dr. Fishenden gives for a coke-fired boiler. On the other hand, for a small household such a boiler is too large, and a small boiler is difficult to fire and keep alight, especially with coke.

The principal cause of loss from a hot water equipment is not so much the low efficiency of the apparatus as the subsequent loss of heat from the storage vessel by radiation. Hot water should be generated when it is required, and this can be done only by gas as in the gas geyser, which is efficient and useful though clumsy and dangerous. If the appliance can be so arranged that the fire can be lighted and burn itself out, a sufficient supply of hot water would be produced for a whole day's use provided the heat was not allowed to escape by proper insulation.

The report contains a lot more useful, practical information as to the method of installation, but perhaps the most significant and encouraging part of the report is the improvement in efficiency which Mr. Barker has himself effected in ranges of his own design whereby he has reduced the fuel consumption by about 70 per cent. It is to be hoped that this new type of range will soon be placed on the market.

J. B. C.

### University and Educational Intelligence.

LEEDS.—The hon. degree of Doctor of Science has been conferred on the following: Sir Charles Scott Sherrington, G.B.E., president of the British Association; the Duc de Broglie, Institut d'Optique, Paris; Dr. C. G. Joh. Petersen, director of the Danish Biological Station, Copenhagen; and Prof. P. Weiss, director of the Institut de Physique, University of Strasbourg.

LONDON.—Mr. T. A. Stephenson of Kingswood School and University College, Aberystwyth, has been appointed assistant in the department of zoology and comparative anatomy at University College.

A programme of public lectures, admission to which is free and without ticket, to be delivered at University College during the coming term, has been issued. It includes lectures on social life in Egypt by Prof. Flinders Petrie, on recent excavations in Malta by Miss M. A. Murray, on the beginnings of science by Prof. G. Elliot Smith, on the nature of intelligence by Prof. C. Spearman, and a series of lectures on phonetics, including one on the nature and reproduction of speech sounds by Sir Richard Paget. At King's College there will be a course of ten lectures by Prof. H. Wildon Carr, commencing on October 5, on the new method of Descartes and the problems to which it gave rise; five lectures by Miss Hilda D. Oakeley on the Stoic philosophy, commencing on November 9; one lecture on October 9, at 5.30, by Prof. G. B. Jeffery on Einstein's theory of relativity; six lectures, commencing October 17, on modern hydro-electric engineering practice by E. M. Bergstrom; and three lectures, commencing November 28, on the fuel problem from an engineering

standpoint by Dr. C. H. Lander. Complete lists of the lectures can be obtained on application, enclosing a stamped addressed envelope, to the secretary of the college in question.

AN article on "The New University of London," by T. L. Humberstone, appears in the *English Review* for September. After showing that so far back as the twelfth century there existed in London all the necessary elements for the formation of a great university, and speculating as to the reasons why, nevertheless, it was not until the nineteenth that one came into being, the writer describes the establishment of the University of London as an examining board in 1836 and its reconstitution as a teaching university in 1900. Of the "third incarnation," now inaugurated with the gift by the Government of eleven and a half acres of land adjoining the site of the British Museum, he writes: "Our task is to open a new Pierian spring to quench a world-thirst"; the new university of London is destined to play a great part in the re-establishment of the cosmopolitan spirit which, under the influence of the Roman Church, tended in the Middle Ages to make Europe a single nation. Time will show whether these aspirations, stimulated by Mr. Fisher's speech at University College last February, can be realised. Meanwhile there is one obstacle, easily removed, to which attention was directed at the recent conference at Basle of delegates from British and Swiss universities. There London's policy in regard to the admission of foreign students was criticised as illiberal. Why, it was asked, should London insist on verifying, by a special matriculation examination, the attainments of students who hold certificates qualifying for admission without further examination into the universities of Switzerland, and implying matriculation standards of attainment in the subjects of the London examination? Cambridge has lately adopted a comprehensive exemption formula recognising the sufficiency of the standards implied by such foreign certificates, and it was hoped that London would do likewise.

THE University of Colorado Catalogue, 1921-22, issued in March 1922 with announcements for 1922-1923, presents several interesting features, exemplifying recent developments in American State universities. The University Extension Division, organised in 1912, "aims to make the campus of the university co-extensive with the State, in keeping with the new idea that a State university exists for all the people and not for a favoured few alone." It has a Faculty comprising 12 administrative and secretarial officers, besides professors and instructors in the various university departments, and a non-resident staff numbering 31. Among its varied activities are: correspondence courses, in which form one-fourth of the work for the A.B. degree may be taken; class instruction, more or less on the lines of our university extension lecture courses, but qualifying equally with courses taken in the university towards degrees; courses in secondary education; social surveys of towns, with a view to the solution of community problems; business surveys for determining the commercial resources and trade possibilities of a community; visits to stores and firms "for the purpose of rendering individual assistance in meeting business problems." Quite distinct from the Extension Division is a "Summer Quarter" of ten weeks, in which are provided courses, some of post-graduate standard, in arts and pure sciences, engineering, medicine, and law. These, if pursued through the whole quarter, carry the same credit as similar courses in any other quarter.

## Calendar of Industrial Pioneers.

September 24, 1852. John Barnes died.—From 1822 to 1835 Barnes was a partner with Joseph Miller, the marine engineer, and as such assisted in introducing steam navigation on the Rhône and Saône. He afterwards designed engines for vessels built by Normand of Havre, among these being the *Napoléon*, the first screw ship in the French Navy. - At the time of his death he was manager of works at La Ciotat near Marseilles.

September 24, 1908. Sir Samuel Canning died.—Born in Wiltshire in 1823, Canning, after some years of railway engineering, joined the firm of Küper and Co., cable makers, of Greenwich, in 1852, and from that time onwards was intimately associated with the development of submarine telegraphy. He took part in the attempt to lay the Atlantic Cable in 1857 and 1858, and as chief engineer of the Telegraph Construction and Maintenance Company he had charge of the making and laying of the second and third Atlantic cables of 1865 and 1866. He was responsible for fitting out the *Great Eastern* and originated much of the cable machinery.

September 25, 1910. Edward Pritchard Martin died.—President of the Iron and Steel Institute and of the Institution of Mechanical Engineers, Martin was a metallurgist who, while manager of the Blaenavon Iron Works, was the first to give facilities for trying on a commercial scale the Thomas-Gilchrist process of dephosphorisation in steel-making. Martin was the son of a mining engineer of the Dowlais Iron Works, and was himself manager of those works from 1882 to 1902.

September 29, 1913. Rudolph Diesel died.—Diesel was born in Paris of German parents on March 15, 1858. He attended school in Augsburg, and at an early age became an assistant to Linde and directed works in Paris where Linde's refrigerators were constructed. Attacking the problem of making a prime mover of higher efficiency than hitherto existed, in 1893 he published "The Theory and Construction of a Rational Heat Motor," and the same year built his first experimental engine. After further trials the manufacture of Diesel engines was taken up by various firms, and to-day they are found in every part of the world. Their superior economy has led to their being fitted in ships; the s.s. *Toiler*, driven by two Diesel engines, crossed the Atlantic in 1911, while to-day more than 1600 vessels of a total tonnage of 1,500,000 tons are driven by internal combustion engines mainly of the Diesel type.

September 30, 1719. Bernard Renou d'Éliçagaray died.—The author of a treatise "Théorie de la manœuvre des vaisseaux," published in 1689, Renou d'Éliçagaray, as a naval officer, saw service afloat and ashore, and at Brest introduced new methods of shipbuilding. He took a leading part in the development of the French Navy under Louis XIV.

September 30, 1772. James Brindley died.—A native of Derbyshire, where he was born in 1716, Brindley served an apprenticeship to a millwright, and afterwards in business in Staffordshire for himself gained a reputation for his ingenuity and skill. For the Duke of Bridgewater he constructed the first British canal, that from Worsley to Manchester. This was completed in 1761, but before Brindley died he had built 365 miles of canal, including the Grand Trunk Canal from the Trent to the Mersey, thus laying the foundation of the British system of inland navigation.

E. C. S.

## Societies and Academies.

PARIS.

Academy of Sciences, August 21.—M. Emile Roux in the chair.—Paul Vuillemin: Disjunction and combination of the characters of the parents in a hybrid. Study of a hybrid of *Aquilegia cærulea* and *A. chrysantha*.—N. Lusin and W. Sierpinski: The decomposition of the continued fraction.—H. Mineur: A class of uniform transcendental functions.—H. A. Perkins: The resistance of thin electrified conducting layers. Experimental study of the effect of an electrostatic charge on the resistance of thin gold film. The film formed one plate of a condenser, and no change in the resistance could be measured with or without an electrostatic charge of 2.7 C.G.S. electrostatic units (800 volts).—F. W. Klingstedt: The ultra-violet absorption spectra of the diphenols. A quantitative study of the normal absorption spectra of the dihydroxybenzenes, made with the Fabry and Buisson microphotometer on photographs taken by V. Henri's method. The meta- and ortho-derivatives have spectra very like that of phenol, but the para-compound has eight nearly equidistant bands instead of the three of phenol. The spectra are modified by certain solvents: with alcohol as a solvent it is impossible to recognise the characteristic differences between the para-compound and ortho- and meta-derivatives. Hexane is the best solvent.—H. Gault and R. Guillemet: The chlorination of normal butyl alcohol. The chief product was found to be the dibutyl acetal of dichlorobutyraldehyde,  $C_4H_9Cl_2(O \cdot CH_2 \cdot CH_2 \cdot CH_2 \cdot CH_2)$ . This acetal is not hydrolysed by aqueous potash, and only slightly hydrolysed by hydrochloric acid or dilute sulphuric acid at 150° under pressure.—G. Vavon and A. L. Berton: The borneol obtained starting with the magnesium compound of pinene chlorhydrate.—G. Murgoci: The properties of the blue amphiboles.—Marcel Mirande: The morphological origin of the internal liber of the Nolanaceæ and the systematic position of this family. The Nolanaceæ have been placed as allied with the Convolvulaceæ or the Solanaceæ: it is shown that this family is well differentiated from the Convolvulaceæ, but may be classified with the Solanaceæ.—A. Guilliermond: Cytological observation on a Leptomitium and in particular on the mode of formation and germination of the zoospores.—Georges Bouvrain: The vascular evolution in Mercurialis.—W. J. Vernadsky: Nickel and cobalt in the biosphere. The constant presence of nickel and cobalt in living organisms has not been proved; but they have been found in all cases when specially sought. They have been found in all the mosses studied in the neighbourhood of Kieff, and in nine species of plants from the same district. Cobalt has also been found in *Echium vulgare* from the Crimea, and in the ashes of a domestic mouse.—Louis Boutan: A fine culture pearl without nucleus.

## Official Publications Received.

Education Committee for the County Borough of Brighton. Municipal Technical College, Richmond Terrace, Brighton. Day Courses, Session 1922-23. Pp. 61. (Brighton.)

The Journal of the Royal Anthropological Institute of Great Britain and Ireland. Vol. 52, January to June, 1922. Pp. 149+13 plates. (London: Royal Anthropological Institute.) 15s. net.

Durham University Calendar for the Year 1922-23. Pp. 756. (Newcastle-upon-Tyne.) 3s. 6d. net.

Fortschritte der technischen Physik. Vorträge von der zweiten Jahrestagung der Deutschen Gesellschaft für technische Physik in Jena vom 19. bis 25. September 1921. Pp. iv.+111. (Leipzig: J. A. Barth.) 48 marks.

# NATURE

A WEEKLY ILLUSTRATED JOURNAL OF SCIENCE.

*"To the solid ground  
Of Nature trusts the mind which builds for aye."*—WORDSWORTH.

No. 2761, VOL. 110] SATURDAY, SEPTEMBER 30, 1922 [PRICE ONE SHILLING

Registered as a Newspaper at the General Post Office.

[All Rights Reserved.

## BALANCES & WEIGHTS

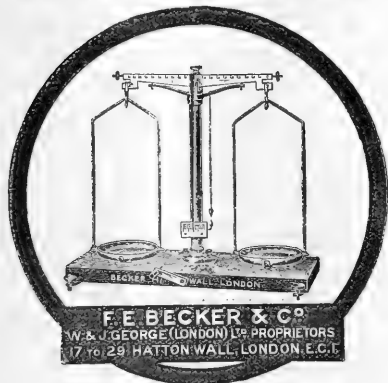

**F. E. BECKER & CO.**  
W. & J. GEORGE (LONDON) LTD. PROPRIETORS  
17 & 29 HATTON WALL, LONDON, E.C. 1.

## REYNOLDS & BRANSON, Limited. "RYSTOS" STILL.

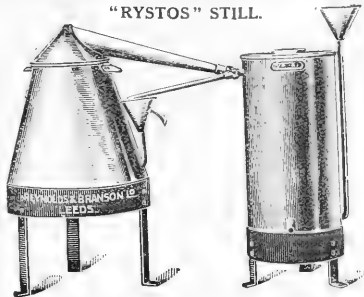

### Improved Central Flue Water Still and Condenser.

In this pattern the heat is conducted through the water by means of a central tube, ensuring economy of heating. The condenser worm is of pure tin, and the water jacket is air-galcoed on two surfaces. One-gallon size (1 litre distilled water per hour), solid copper. Ring Burners for same. Price of various sizes on application.

Catalogue of Chemical Apparatus and Chemicals, post free.

14 COMMERCIAL STREET, LEEDS.

## SPECTROMETERS

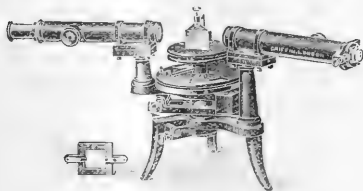

Particulars and Prices on application to—

**JOHN J. GRIFFIN & SONS, LTD.**

Kemble Street, Kingsway,  
London, W.C.2.



CERTIFICATE  
— OF —  
EXAMINATION  
OF

Fahrenheit Thermometer No. 9.10560, etc.

Name on Thermometer — *Reynolds & Branson*.

Corrections to be applied to the Scale Readings, determined by comparison with the Standard Instruments at the National Physical Laboratory, Teddington. The corrections are given in the next column.

TEMPERATURE	CORRECTION
32°F	0
40	0
50	0
60	+1
70	+2
80	+3
90	0

Note: 1. When in use, the thermometer should be kept in the liquid in which it is used.

Note 2. The thermometer should be kept in the liquid in which it is used.

Note 3. The thermometer should be kept in the liquid in which it is used.

Note 4. The thermometer should be kept in the liquid in which it is used.

Note 5. The thermometer should be kept in the liquid in which it is used.

Note 6. The thermometer should be kept in the liquid in which it is used.

Note 7. The thermometer should be kept in the liquid in which it is used.

Note 8. The thermometer should be kept in the liquid in which it is used.

Note 9. The thermometer should be kept in the liquid in which it is used.

Note 10. The thermometer should be kept in the liquid in which it is used.

REYNOLDS & BRANSON

REYNOLDS & BRANSON

## IMPERIAL COLLEGE OF SCIENCE AND TECHNOLOGY.

SOUTH KENSINGTON, S.W.7.

### DEPARTMENT OF OPTICAL ENGINEERING AND APPLIED OPTICS.

The Following Courses of Weekly Lectures will commence during the Autumn Session, 1922.

1. GENERAL OPTICS (ELEMENTARY). Professor Cheshire. Commencing Wednesday, October 4, at 4 P.M.
2. ADVANCED OPTICS. Professor Cheshire and Dr. Martin. Commencing Monday, October 9, at 12 noon.
3. OPTICAL DESIGNING AND COMPUTING. Professor A. E. Conrady. Commencing Tuesday, October 3, at 10 A.M.
4. WORKSHOP AND TESTING ROOM METHODS. Professor A. E. Conrady. Commencing Wednesday, October 4, at 2 P.M.
5. ADVANCED DESIGNING AND COMPUTING. Professor A. E. Conrady. Commencing Wednesday, October 4, at 10 A.M.
6. CONSTRUCTION, THEORY AND USE OF OPTICAL MEASURING INSTRUMENTS. Dr. Martin. Commencing Friday, October 6, at 12 noon.
7. MECHANICAL DESIGN OF INSTRUMENTS. Professor Pollard. Commencing Tuesday, October 3, at 12 noon.
8. ELEMENTARY ELASTICITY AND STRENGTH OF MATERIALS. Professor Pollard. Commencing Friday, October 6, at 2 P.M.
9. MACHINE DRAWING. Professor Pollard. Commencing Friday, October 6, at 3 P.M.

The following Special Courses of Lectures will be given:—

- POLARISED LIGHT AND POLARISATION APPARATUS. A Course of six weekly lectures, beginning on Tuesday, October 10, at 4 P.M., will be given by Professor Cheshire. The course will be repeated during the Summer Term on Mondays at 6.30 P.M., commencing April 30, 1923.
- ELEMENTARY ELASTICITY AND STRENGTH OF MATERIALS. A Course of six weekly lectures will be given by Professor Pollard on Thursdays at 5 P.M., commencing January 18, 1923.
- COLOUR AND ITS MEASUREMENT. A Course of ten weekly experimental lectures, beginning on Tuesday, January 16, 1923, will be given by Dr. L. C. Martin.

For further particulars and for admission tickets apply to the REGISTRAR at the above address.

The Director is open to receive applications from students and others desirous of carrying out research work in the Laboratories.

### ENGINEERING AND TECHNICAL OPTICS.

## NORTHAMPTON POLYTECHNIC INSTITUTE,

ST. JOHN STREET, LONDON, E.C.1.

### ENGINEERING DAY COLLEGE.

Full-time Day Courses in the Theory and Practice of Civil, Mechanical, and Electrical Engineering. The Courses in Civil and Mechanical Engineering include specialisation in Automobile and AERONAUTICAL Engineering, and those in Electrical Engineering include specialisation in RADIO-TELEGRAPHY.

A SPECIAL ENTRANCE EXAMINATION is held at the end of September before the commencement of each session. The Courses include periods spent in commercial workshops and extend over four years. They also prepare for the Degree of B.Sc. in Engineering at the University of London. Fees £18 or £13 per annum.

THREE ENTRANCE SCHOLARSHIPS of the value of £50 each for the complete course are offered for competition at the annual entrance examination in September.

### OPTICAL ENGINEERING AND TECHNICAL OPTICS.

Full- and Part-Time Courses in this important department of Applied Science are given in specially equipped laboratories and lecture rooms. The annual entrance examination is held at the end of September.

### EVENING TECHNICAL COURSES

in all branches of Mechanical and Electrical Engineering commence on Monday, September 25, 1922.

The Laboratories, both Mechanical and Electrical, are well equipped with modern apparatus which, on the Mechanical side, provides for specialisation in Automobile and Aeronautical Engineering, and on the Electrical side, for specialisation in Alternate and Continuous Current Work, in Radio-Telegraphy and Telephony, and in Electrical Testing.

More complete particulars, together with conditions of entrance, etc., and all information respecting the work of the Institute can be obtained at the Institute or on application to

R. MULLINEUX WALMSLEY, D.Sc., Principal.

## AUTHORS' TYPIST.—4th year Chemical

Student undertakes typing of scientific papers, authors' MSS., etc. Good knowledge of French and German. Box 10, c/o NATURE Office.

## CHELSEA POLYTECHNIC,

CHELSEA, S.W.3.

Session begins September 25, 1922.

Day and Evening Courses in Science under Recognised Teachers of London University.

### I. INDUSTRIAL CHEMISTRY DEPARTMENT.

Technical Courses in Analytical and Manufacturing Chemistry, Pharmacy, Food and Drugs, A.I.C. Courses, Metallurgy, Assaying, Foundry Work, Research.

### II. INDUSTRIAL PHYSICS DEPARTMENT.

Practical work in General Physics, Applications to Industries, Metrology, Calorimetry, Illumination, Acoustics, Electrical Measurement, Research.

### III. BIOLOGICAL AND GEOLOGICAL DEPARTMENT.

Courses for B.Sc., etc., in Botany, Geology, Mineralogy, Zoology, Special Courses in Bio-chemistry, Bio-physics, Bacteriology, Physiology, Hygiene, Entomology, Plant Pathology. Course for Tropical Planters, Research.

Telephone: Kensington 899.

SIDNEY SKINNER, M.A.,  
Principal.

## BATTERSEA POLYTECHNIC.

Principal—ROBERT H. PICKARD, D.Sc., F.R.S.

University Courses, day and evening, under Recognised Teachers of the University of London are provided in Science, Engineering and Music.

CHEMISTRY.—J. KENYON, D.Sc., F.I.C.; J. L. WHITE, D.Sc.  
PHYSICS.—S. MARSH, B.Sc., Ph.D.; A. E. EVANS, B.Sc.; J. P. PHILLIPS, B.A., B.Sc.  
MATHEMATICS.—F. M. SÆVELDY, M.Sc., B.A.; F. W. HARVEY, B.Sc., M.A.; W. G. RIGLEY, M.Sc.  
MECHANICAL AND CIVIL ENGINEERING.—W. E. M. CURSON, M.Sc., B.Eng.; J. B. SHAW, A.R.C.S., Wh.Eng.; H. M. EDMONDS, B.Sc.; V. C. DAVIES, B.Sc., A.M.I.Mech.E.  
ELECTRICAL ENGINEERING.—A. T. DOVER, M.I.E.E., A.M.I.E.E.; H. C. MANN, A.M.I.E.E.  
MUSIC.—H. D. WETTON, Mus. Doc., F.R.C.O.

\* Denotes recognised teacher of University of London.

There are also:—

- Day Technical College in Engineering and Science. Day Training College of Domestic Science. Day Department of Hygiene and Physiology. Day School of Art and Crafts.
- Evening Courses in Engineering, Chemistry, Physics, Mathematics, Bacteriology, Chemical Engineering, Hygiene and Physiology, Art, Matriculation Subjects, Domestic Economy, Music, Physical Training.
- Hostels for Women Students. Large playing fields at Merton.

## NATIONAL UNION OF SCIENTIFIC WORKERS.

25 VICTORIA STREET, WESTMINSTER, S.W.1.

The main object of the Union is to secure in the interests of national efficiency that all scientific workers are given the fullest opportunity of working up to the hilt of their capacity in the service of the community.

There are now eighteen branches of the Union. They include those formed by:

- (i) University Scientific Staffs and Research Workers and Scientific Staffs in other teaching institutions;
- (ii) Government Scientific and Technical Staffs;
- (iii) Scientific workers in Industry.

The General Secretary of the Union will be pleased to arrange for members of the Executive to address meetings of industrial, Government departmental, or university scientific workers, on the work of the Union.

A list of members and the Annual Report for the year 1920-21 will be sent on application to

THE GENERAL SECRETARY,

at the above address.

## THE QUEEN'S UNIVERSITY OF BELFAST.

### DEPARTMENT OF PHYSICS.

Applications are invited for the LECTURESHIP in PHYSICS. Salary £450 per annum.

Particulars of the appointment may be had from

J. M. FINNEGAN, Secretary.

## SALTERS' INSTITUTE OF INDUSTRIAL CHEMISTRY.

The Committee will shortly allocate a limited number of Grants in Aid to junior assistants in chemical works laboratories in or near London who desire to extend their knowledge of chemistry. Applications, with full particulars of age, nature of employment, and manner in which the grant will be used, will be considered in priority of receipt, and should be sent before October 7, to the DIRECTOR OF THE INSTITUTE, Salters' Hall, St. Swithin's Lane, E.C.4.



SATURDAY, SEPTEMBER 30, 1922

## CONTENTS.

	PAGE
The Protection of Inventions: An Empire Patent . . . . .	437
Industrial Physics. By Major G. W. C. Kaye . . . . .	439
Position of Agriculture in India. By Dr. B. A. Keen . . . . .	442
Prehistory for the Schoolroom. By G. A. J. C. . . . .	443
Aesthetics . . . . .	443
Our Bookshelf . . . . .	444
Letters to the Editor:—	
Relativity and the Ether.—Sir Oliver Lodge, F.R.S. . . . .	446
The Legal Equivalent of the Metre.—Sir R. T. Glazebrook, K.C.B., F.R.S. . . . .	446
On the Reality of Nerve-Energy.—Dr. E. D. Adrian . . . . .	447
Interspecific Sterility.—Prof. R. Ruggles Gates . . . . .	447
Micro-chemical Methods in the Practical Teaching of Chemistry.—J. W. Blagden and A. Wechsler . . . . .	447
The Progression of Life in the Sea. By E. J. Allen, D.Sc., F.R.S. . . . .	448
The Efficiency of Man and the Factors which influence it. By Prof. E. P. Cathcart, M.D., D.Sc., F.R.S. . . . .	453
The Total Solar Eclipse of September 21. By Dr. A. C. D. Crommelin . . . . .	457
Obituary:—	
Prof. Alexander Smith. By J. W. . . . .	457
Dr. Sophie Bryant. By M. H. W. . . . .	458
Current Topics and Events . . . . .	459
Our Astronomical Column . . . . .	461
Research Items . . . . .	462
The Inheritance of Size . . . . .	463
An Optical Sonometer. ( <i>Illustrated</i> ) . . . . .	464
The Rowett Research Institute, Aberdeen . . . . .	464
The Sun's Activity, 1890-1920. ( <i>With diagram</i> ) . . . . .	465
University and Educational Intelligence . . . . .	466
Calendar of Industrial Pioneers . . . . .	467
Societies and Academies . . . . .	467
Official Publications Received . . . . .	468
Diary of Societies . . . . .	468

*Editorial and Publishing Offices:*

MACMILLAN & CO., LTD.,

ST. MARTIN'S STREET, LONDON, W.C.2.

Advertisements and business letters should be addressed to the Publishers.

Editorial communications to the Editor.

Telegraphic Address: PHUSIS, LONDON.

Telephone Number: GERRARD 8830.

NO. 2761, VOL. 110]

## The Protection of Inventions: An Empire Patent.

COMMON legislative action among the constituent parts of the British Empire would materially strengthen the bond which unites the peoples to one another and to the motherland. When, in addition, increased productiveness, lessening of cost, and simplification of procedure are its accompaniment, and when general expediency points to the special course prescribed by it, few voices could well be heard in opposition. For many years a dream of politicians and reformers, manufacturers and inventors, has been the granting of a single patent to an inventor which, effective throughout the British Dominions, would give adequate protection without the necessity of securing patents from each of the constituent countries of the Empire. To obtain this wide measure of protection, an inventor, at the present time, must make not less than forty-six separate applications at a cost in official fees of more than three hundred pounds. Further, if protection be desired for the full periods which the respective laws permit, an additional sum of twelve hundred pounds and more must be forthcoming; and to this sum there is to be added the cost of the highly skilled preparation of the necessary documents, a formidable item which alone may amount to as much as the official fees for the applications. Now, if it were genuinely believed by all classes that the stimulation of invention results in greatly increased production, and that trouble and outlay in that direction are amply repaid, expenditure by governing bodies would no longer be deemed speculative, but would be looked upon as a sure and certain investment to be welcomed on all hands.

Although there is much to be urged in favour of this belief, possibly to the point of conviction, many reasons may be adduced for its non-acceptance by the authorities. The reasons, however, need not be specified, for the fact remains that hitherto there has been no such consensus of opinion as to lead the separate law-making bodies to common action and, through simplification of procedure and great reduction in cost, to encourage the inventor to successful effort within the territories of the several legislatures. Yet until the year 1852 it was the practice in this country to issue a single patent which was co-extensive in its operation with the whole of the Colonies, and in the Patent Law Amendment Act of that year a similar power was reserved. Although this power was not employed, for, in fact, no extensions were made, the reservation in the Act secured a practical result. It set on foot a series of inquiries by the Government, and led India and the Colonies to pass various patent

acts and ordinances. Simultaneously with the demand in the 'sixties of last century for the total abolition of patents, opinion was hardening upon the desirability for the extension of a patent to countries other than that in which it originated. In the Patents Act of 1883, which replaced the Act of 1852, no power was given for extending the territorial limit of a patent, nor in the Acts which now govern patents in this country is any such power present. In spite of much sporadic agitation, no practical steps were taken for a patent of the United Kingdom to become operative in India, the self-governing Dominions, the Colonies, and Protectorates. This invoked Sir Robert Hadfield to say that "It is a crying shame that in a great Empire like ours we do not have one Empire Patent to cover the whole of our Dominions."

Although many societies and various learned bodies had discussed the question and emphasised the need of an Empire Patent, and, from time to time, had made representations to Government, officialdom appears to have been deterred by inherent difficulties in the production of an acceptable scheme. It had not perceived the possibility of formulating a practical measure to satisfy the justifiable aspirations and fair demands of inventors. But steady pressure and persistent endeavour are meeting with reward, for there are now indications of Governments treating seriously the proposals for an Empire Patent. A notably important advance was made in 1921 at a conference of Prime Ministers and representatives of the United Kingdom, the Dominions, and India, when a memorandum, prepared in the Board of Trade, was discussed by a special committee. The conference agreed with the recommendation of its committee that representatives of the Patent Offices of His Majesty's Dominions should sit in London to consider the practicability of an Empire Patent. Accordingly sittings were held in June last, and a report of the conference has since been published.<sup>1</sup>

The report is not for popular reading; indeed in the main it is highly technical, and in its entirety can be understood only by those to whom the details of patent law and practice are of everyday concern. Further, its importance and significance are not to be measured simply by what it states expressly, since its implications and inferences must be gathered before its true import can be realised.

The discussion at the conference ranged round the present situation of affairs; the desirability for an Empire Patent; various schemes for obtaining the Patent and their practicability; and alternatively the possibility of rendering uniform the patent laws

<sup>1</sup> British Empire Patent Conference. Report of the Conference held at the Patent Office, London, from 12th June 1922 to the 23rd June 1922. 8vo. Pp. 28. (London: H.M. Stationery Office.) 1s. net.

throughout the Empire. The conference, while emphasising the importance of the preservation of the autonomy of the self-governing Dominions and of India, and insisting upon the rights and facilities at present enjoyed by inventors, concluded that an Empire Patent is desirable. Five schemes of the many that had been brought to notice were selected for special examination, the conference taking for its basis a memorandum prepared by the Comptroller General of Patents in 1919. A few particulars of these schemes are set out in the report. Looking over these, it is apparent that for each much can be urged. In one, it may be, large expenditure is involved, although the advantages to be secured are great; in another, expenditure is comparatively small, with corresponding diminution in beneficial results. That difficulties will be encountered whatever scheme may ultimately be adopted is well known, but so far as can be judged, no such difficulty will be met as cannot be surmounted in the presence of a spirit of give-and-take, a spirit which must permeate the various legislatures and governing bodies before a uniform plan of action can be agreed upon.

According to one of the schemes, there is to be established a single central patent office for the issue of grants which should be operative throughout the Empire, local patent offices being abolished. This scheme was not approved, "having regard to practical difficulties," the chief of which were the distance apart of the units of the Empire and the loss of time which accordingly would be involved in transacting the necessary business. Another scheme contemplated the retention of local patent offices from which the usual territorial patents would issue, the issue taking place without examination into the novelty of the inventions to be protected. In addition, a central office would be established for the recording of the local patents and for their resultant extension to the Empire. The central office on being called upon by its patentees would also undertake a limited examination for novelty, and when the patent specification was suitably amended as a result of the examination, a note would appear that the examination had thus taken place. This scheme was not recommended, owing, it would seem, to the resulting abolition of the existing compulsory examination into novelty. The third scheme entailed the granting of Empire Patents in each self-governing Dominion and in India, each office being fully equipped with the registers and material necessary for the examination into novelty. In view of the expense and difficulty involved in setting up the offices and of the uncertainty as to the quality and value of the patent so granted, the conference found the scheme to be wholly impracticable. According to the "Preferred



Scheme," a scheme which the conference recommended for adoption in the future, local patent offices are to be retained, each performing its present functions. There is also to be a fully organised central office for the detailed examination of applications for patents, the examination to include an extended search for novelty, the office eventually, issuing the Empire Patents. But to make a patent operative in any country, registration in that country is compulsory, the registration being open to opposition if the local law provides for opposition to the granting of a patent.

By a "Provisional Scheme," which is recommended for immediate adoption and for continuation until the "Preferred Scheme" can be introduced, the grant of a patent in the United Kingdom carries with it the right to registration in any desired country of the Empire, the act of registration extending the grant to that country. But here, again, before the registration is made, it is open to opposition, if opposition to local grants is permitted by the local law.

Manifestly, whatever scheme came to be adopted by the separate legislatures or law-making bodies, much mutual adjustment of substantive and adjective law would be required. Some of these necessary adjustments were discussed at the conference, and suggestions emanating therefrom appear in the report. None appears to be of such a character as to be outside the bounds of practicability. But to review those subjects which call for adjustment, and to discuss the opinions on these and other points expressed at the conference, would require for each a monograph. From the report it is clear that an extremely small portion of the necessary amendments which the respective authorities would be called upon to make could have been discussed, bearing in mind that the conference held ten meetings only, and that it refused to admit oral evidence from outside, deciding that "no useful purpose would be served by hearing such evidence." There was, therefore, excluded from consideration the oral evidence that could have been given, for example, by the Chartered Institute of Patent Agents, a body which is continually in touch with the needs of inventors and conversant with the working and details of the various patent laws. Of necessity must the conference be looked upon as merely preliminary to attacking at close quarters the problem which it set out to solve.

On the unanimous selection of a scheme by each of the governing authorities, the next step will be for each to submit for general consideration the law, rules, and regulations which must be formulated in order that the selected scheme may be successfully put into operation. Moreover, it will be necessary to distinguish between the law to be applied when the patent is granted and

the procedure for obtaining the patent. It will also be found that, in endeavouring to secure a basis for action, the task will be the easier by reason of the large majority of the patent laws of the Dominions having copied the law of the United Kingdom, and of the ultimate Court of Appeal for the Empire being the Judicial Committee of the Privy Council.

In the preparation of a scheme for general adoption it is to be hoped that the authorities will not continue to ignore oral evidence from outside bodies; to do so will be to court failure. Procedure for obtaining a patent and the law and rules relating to patents are so intricate that none but those who are in daily contact with such matters and have learned in the hard school of experience the needs of inventors on one hand and the reasonable requirements of the public on the other, can be expected to produce a scheme which, satisfactory to all parties, can be put into operation without friction, much change in procedure, or extensive amendment of existing laws.

There is no reason to suppose that, if all parties are determined to produce an Empire Patent, the adjustment of conflicting opinions cannot be made nor suitable machinery devised. The result undoubtedly would be to the advantage of all inhabitants of the Homeland and of His Majesty's Dominions beyond the Seas, whether as inventors, manufacturers, or users. It remains, therefore, for the public to urge expedition upon the authorities, or it will be met with the charge of apathy, a plea which so often saves the situation where officials are concerned.

A word or two is to be said in respect of the charge for a copy of the report. In pre-war days, each copy of this small octavo would have been sold for 3*d.* or 4*d.*, and the edition promptly exhausted with a consequent wide-spread dissemination of its information. For each copy of this edition of five hundred, however, one shilling is required, a charge which scarcely makes for extensive circulation. The wider the public that the report reaches, the greater chance of a definite outcome of its suggestions, while, at the same time, by the lowering of the price the probability of the recovery of the cost of the edition would not be appreciably lessened.

### Industrial Physics.

*A Dictionary of Applied Physics.* Edited by Sir Richard Glazebrook. (In 5 volumes.) Vol. 1: Mechanics, Engineering, Heat. Pp. ix + 1067. (London: Macmillan and Co., Ltd., 1922.) 3*l.* 3*s.* net.

**I**N years to come the publication of this monumental work will rank as one of the milestones in British applied science. If argument were needed, none more

convincing could be adduced in illustration of the necessity for a working co-operation between the physicist and the engineer. Sir Alfred Ewing recently defined engineering as "the turning to man's use and convenience of the things which it is the business of physics to understand." This Dictionary helps one to realise, as perhaps never previously, that in all branches of engineering the engineer, whether revealing or directing, whether inventing or designing, whether testing or measuring, whether systematising, co-ordinating, or clarifying, is continually turning physical principles to account.

Sir Richard Glazebrook, not content with the enduring monument to his fame in the shape of the National Physical Laboratory, has now laid physicists and engineers under perpetual obligation by undertaking the editorship of this "Dictionary of Applied Physics." No other British man of science, it is safe to say, could have brought the same wide experience, intimate knowledge, and critical judgment to bear upon the production of an encyclopædic work of this nature. For twenty years Sir Richard Glazebrook directed the policy of the N.P.L., and during that period, when the attitude of the nation towards scientific investigation was very different from what it is to-day, he toiled unceasingly to foster the applications of science to industry. To take one example alone, the fact that this country in 1914 led the world in aeronautical research is due in no small measure to his foresight and skilful guidance during the preceding eight years. Sir Richard's breadth of interests and his habit of establishing and preserving personal contact with original investigators are reflected in his choice of collaborators in the preparation of this Dictionary.

The work under review is the first of a series of five volumes, planned to cover the entire range of physics and, in particular, the applications of physics to industry. Volume 1 contains some fifty articles, covering mechanics, engineering, and heat.

Three main facts emerge from a survey of the work before us—first, the unexampled wealth of material; secondly, the authoritativeness, the maturity of judgment, the originality and inviting freshness of treatment which are exhibited by the majority of the writers; and, lastly, the presumption and utility of any single reviewer attempting to appraise such a diversity of articles by such a galaxy of experts. A glance at the names of contributors furnishes sufficient guarantee that the various subjects are dealt with by accepted authorities and experienced investigators; and probably the only useful service that a reviewer can hope to perform is to point out a few of the sins of omission which are inevitable in a treatise planned on such a comprehensive scale.

The first article in the volume is on air pumps, by the staff of the General Electric Co., and deals with the fundamental principles of the various types of pumps employed for evacuation and compression.

Calorimetric measurements are dealt with in a series of five articles by Dr. Ezer Griffiths. The subject is divided into sections dealing with bomb calorimetry, electrical methods of calorimetry, method of mixtures, methods based on change of state and the applications of the quantum theory to specific heat data. A glance through these articles shows how different are the methods employed by research workers from those described in text-books on this subject. As an indication of the highly developed state of technical calorimetry, it might be mentioned that with one of the bomb-calorimeter equipments described—that of the U.S. Bureau of Mines—a skilled operator can average thirty-five determinations per day of the calorific value of fuels. The purely scientific aspect of the subject is not neglected, for we find concise descriptions of the researches of White on specific heats at high temperatures and those of Dewar at low temperatures. Electrical methods of calorimetry naturally occupy a prominent place, for the ease with which electrical energy can be measured and controlled has placed a powerful tool in the hands of workers concerned with thermal measurements.

The principles of dynamical similarity are discussed in an article by Dr. H. Levy. The results of wind-channel and ship-tank experiments on models can be applied to full-scale machines by the use of the Principle of Similitude, which also finds application in numerous other branches of engineering. One is reminded of a famous article by the late Lord Rayleigh in *NATURE*, vol. 95, p. 66, 1915, in which the full generality and beauty of the Principle of Similitude are brought out. In the space of a column or two Rayleigh deduced a series of fundamental conclusions with the lucidity and brevity which distinguish all his writings.

Four articles are devoted to various aspects of steam engineering. Sir Alfred Ewing contributes one on the theory of the steam engine; Mr. A. Cruickshank another on the reciprocating steam engine, while the importance of the steam turbine fully merits the 38 pages devoted to the two articles on the physics of the steam turbine by Dr. Gerald Stoney and Mr. Telford Petrie, and the development of the steam turbine by Mr. R. Dowson of Messrs. Parsons.

These articles cover the ground pretty thoroughly, so far as present-day practice goes, but one would have liked to know something of the writers' views on the future trend of their subjects. For example, nothing is said of the possibilities of the gas turbine, should the practical difficulties connected with it be overcome, or

of the advantages and disadvantages of the steam turbine for aircraft propulsion and on locomotives.

The internal combustion engine is dealt with in three articles: Mr. Aubrey Evans writes on the water-cooled petrol engine; Sir Dugald Clerk and Mr. G. A. Burls on the thermodynamics of internal combustion engines and also on some typical internal combustion engines. The standard work of these authors on the subject is familiar to most students.

On general engineering subjects we note, among many others, a brief monograph by Prof. W. E. Dalby on the balancing of engines and prime movers. In an article on the strength of structures by Mr. J. W. Landon, it is curious that no mention is made of airship and aeroplane structures, which are certainly of considerable interest at the present time.

Dr. T. E. Stanton's article on friction, supplemented by a very brief one by Mr. W. B. Hardy on boundary conditions in lubrication, form a complete and masterly résumé of this fascinating subject, in which there have been considerable developments during the past few years.

Elasticity has two articles devoted to it, one on the theory of elasticity by Mr. R. V. Southwell, and the other on elastic constants by Mr. R. G. Batson. Mr. Southwell's article of 11 pages is as brief as Mr. Batson's article of 125 pages is long. One would have liked to see included in the former a brief account of the mathematical researches which find practical application, such as the effect of keyways on the strength of a shaft, the vibration of rotating masses, such as turbine discs, the torsional vibration of propeller shafts, etc. Mr. Batson's article, which is lavishly illustrated, deals primarily with the testing of the materials of construction. We note that Fig. 120, p. 196, has evidently been transferred direct from a catalogue without the superfluous lettering being removed. In view of the thorough treatment of the subject of thermoelectric pyrometry in this volume, there was doubtful justification for including an elementary account of the principle of thermoelectric pyrometers in an article devoted to elasticity. Moreover, the sections on the permeability of concrete, together with those on attrition and abrasion tests, are somewhat uncomfortably housed in an article on elastic constants. The question of the seasoning and testing of timber merits a more exhaustive treatment than is accorded to it here.

Space does not permit of a review of the numerous short articles on various aspects of engineering, but some of the omissions may be pointed out for future rectification. In the brief article on gyroscopes by Dr. G. T. Bennett, no mention is made of important practical applications, such as gyro-compasses, stabilisers, and aeroplane-level indicators. The article on

dynamometers, by Mr. J. H. Hyde, is confined mainly to the more familiar types. One would have liked, for example, to know something of those developed for testing aircraft engines during flight.

Mr. F. H. Schofield contributes articles on heat conduction and convection, the recent work of the Heat Department of the National Physical Laboratory on these subjects being well summarised. The classical researches on the mechanical equivalent of heat are ably reviewed by Dr. E. H. Griffiths. Reading his account of the difficulties encountered by early workers makes us realise how much they did indirectly to advance progress by following up the discrepancies between various temperature scales on one hand and the several electrical standards on the other. Sir Alfred Ewing contributes articles on thermodynamics, the liquefaction of gases and refrigeration, which are models of charm and clarity. The article on liquefaction might well have been amplified to include the advances of the last few years.

Temperature measurements are covered in a series of six articles. Messrs. Day and Sosman of the Geophysical Institute, U.S.A., are authors of an article on the realisation of the absolute scale of temperature. In this most readable contribution will be found a critical review of the numerous researches on the gas thermometer throughout the past century, which have helped to lay the basis of the standard scale of temperature in use at the present day.

Dr. Ezer Griffiths contributes noteworthy articles on resistance thermometers, thermocouples, total radiation pyrometry, and optical pyrometry. The resistance thermometer holds a unique position in practical pyrometry. Too fragile for works' use, as originally intended by Siemens, it has developed into a precision laboratory instrument. The practical scale of temperature over the range  $-40^{\circ}$  C. to  $+1100^{\circ}$  C. can be reproduced with extraordinary accuracy by the aid of a platinum resistance thermometer calibrated at the ice, steam, and sulphur points. Detailed descriptions of the methods to be employed in calibration and the precautions which must be observed will be found in the article.

As modern methods of measuring temperature have developed chiefly in the direction of electrical appliances, one naturally finds that prominence is given to a discussion of various types of potentiometers in the article on thermocouples. Considerable advance has been made in recent years in the design of thermoelectric potentiometers, and the student of purely electrical measurements might also with advantage study this section.

A notable feature of the article on optical pyrometers is the discussion of the theory underlying the

use of red glass for obtaining approximately monochromatic light. This is a factor of fundamental importance when temperatures of the order of 3000° C. have to be measured by means of pyrometers calibrated on the basis of Wien's law to represent the distribution of energy in the spectrum of a "full radiator." The "disappearing filament" type of pyrometer has been greatly developed in recent years at the N.P.L. and elsewhere, and it would appear that, in time, it will supplant most of the other types now in use for high-temperature measurements.

Thermometry is covered by a comprehensive article written by Mr. W. F. Higgins. A detailed account is given of the N.P.L. equipment for thermometer testing, together with a complete discussion of the mercurial thermometer. No consideration is given to vapour-pressure thermometers. During the war many thousands per week were made for use on aircraft, and they are also being extensively fitted to motor-car radiators at the present time. Doubtless the new mercury-in-steel transmitting thermometers, which have been successfully developed and are coming into wide use, will receive a longer notice in a future edition.

Mr. G. S. Baker writes on ship resistance, Prof. Horace Lamb contributes mathematical articles on Fourier's series, etc., Dr. A. W. Porter treats of thermal conductivity, and Mr. Jakeman deals with the measurement of pressure.

We regret that we have not space to notice the numerous short articles scattered throughout the volume, some of which are intended to supplement the longer articles.

There is an excellent name-index. The references are plentiful, and appear to have been carefully checked. The only slip which we have noticed is on page 1025, the Physical Society modestly confining itself to Proceedings, not Transactions, as implied by the writer. We notice that the names of Mr. Whetham (Phase Rule) and Miss Austin (Units of Measurement) have been omitted from the list of contributors on p. vii.

The printers have done their work well, and the publishers are to be congratulated on their enterprise and the general "turn-out" of the book. It was inevitable that a book of 1000 or more pages of this type should be expensive. The pity of it is that the price will put it out of the reach of so many students. It is true that they may have recourse to the nearest library, but the book is such that one would like to see every senior student of the subject with his own copy. Some of the articles will be a revelation to him, bearing as they do little resemblance in substance and treatment to the majority of the present-day text-books.

The division of the Dictionary into volumes on a subject-basis, and the fact that individual volumes are purchasable, are features greatly to be commended. Perhaps in the future it may prove possible to extend the system and divide the Dictionary into, say, double the number of smaller volumes, each confined to one main branch of the subject, and proportionately less costly. The volumes would be lighter to handle, and the formidable task of keeping so large a work abreast of modern science would be much facilitated.

G. W. C. KAYE.

### Position of Agriculture in India.

*Agricultural Progress in Western India.* By G. Keatinge. Pp. xii + 253. (London: Longmans, Green and Co., 1921.) 6s. net.

AGRICULTURAL conditions in India are such that any estimate of progress must be largely indirect. The bulk of the land is farmed in small holdings by peasants who keep no accounts, and sell their surplus products in local markets which render no statistical returns; again, the value of export crops, such as cotton, is subject to wide fluctuations owing to the erratic rainfall. But, by a consideration of other factors, such as the area under cultivation, changes in land values and rentals, irrigation schemes, and the standard of living, there is definite evidence of progress. Mr. Keatinge has spent thirty years in the midst of agricultural problems in the Bombay Presidency, and in this very interesting book he sets out his estimate of the progress that has been made, the obstacles to further advancement, and a proposed future policy.

With regard to the obstacles in the way of further advancement, the most serious one is the Hindu law of inheritance, by which each male member of a family is entitled to an equal share of the family property. This results, not only in the division of farms into uneconomic units, but in a further subdivision into scattered plots—a process reminiscent of the old three-field system in England. Another fundamental difficulty is that cattle cannot be bred and kept solely for profit, owing to their significance in the Hindu religion. They are of inefficient types, used of necessity in an uneconomic manner, and are more of a hindrance than a help to the struggling farmer. As an illustration of the difficulty of introducing improvements which do not clash seriously with the social and religious habits of the cultivators, the author considers the use of irrigation water. It appears that, financially, most irrigation canals are unsuccessful owing to the slow manner in which these facilities are

taken up. This is due to the small number of men who have the necessary capital, skill, and energy to engage in the more intensive type of cultivation necessary on irrigated land.

In certain matters of technique, such as improvements in cultivation and rotations, the application of manures and the use of better seed, considerable advances have been effected. This is largely due to the investigations made at the experimental farms of the Agricultural Service.

In one of the appendices to the book the author outlines a draft bill to enable landowners to correct the excessive division of holdings, and he supports his case by full details of typical instances of subdivision, and by comparison with the remedial measures taken in other countries where the same conditions have arisen.

The book is essentially a plea for a specified course of legislative action, and therefore may be to some extent controversial, especially at the present time; but the facts are put forward in an eminently fair manner, and the author's treatment and discussion of them constitute an exceedingly interesting and useful account of agricultural conditions in an important region of India.

B. A. KEEN.

### Prehistory for the Schoolroom.

(1) *Everyday Life in the Old Stone Age*. Written and illustrated by M. and C. H. B. Quennell. (The Everyday Life Series, I.) Pp. x+109. (London: B. T. Batsford, Ltd., n.d.) 5s. net.

(2) *The World-Story of 3,000,000,000 (?) Years*. By J. Reeves. Pp. 16. (London: P. S. King and Son, Ltd., 1922.) 2s. 6d. net.

(1) **T**HIS is a delightful book. It ought to be in every schoolroom; but the elders will want to borrow it and enjoy it in the evenings. The line drawings are masterpieces of well directed imagination. That on p. 48 shows a Mousterian family between the thin stems of the woodland and their cave; the big brother, just for fun, is frightening a little girl, who clings to her mother's back as she looks after the fire; an elder sister, sitting near him, checks him by a timely touch from her leg—her foot is just as ready as her hand. The 130 square cm. of the drawing—the authors justly use the metric scale—are full of life and incident; we should like to see the curtain rising on its realisation as the first scene of a folk-drama.

The clever guesses at the appearance in profile of successive types of man, from Pithecanthropus to the Magdalenian, should be supplemented by a few drawings of the actual skulls. There is no ugly suggestion

nowadays about a skull, and readers would then see clearly on what the conclusions rest. The picture of a small valley-glacier producing a moraine-girdle is crude, and does little to explain the conditions found by earliest man in Europe. The absurdly small thickness assigned to Cainozoic strata in the table is sanctioned by British Museum guides, and is derived from the narrow cult of the London Basin by geologists in southern England. But we turn to the text and the living illustrations, to the proud dignity of *Cervus giganteus*, unconscious of his vulgar little enemy in the rear, and to the sleepy hippopotamus about to fall upon the stakes; then once more we cordially thank the authors:

(2) So much is problematic when we seek to summarise "the world-story" that we doubt the wisdom of drawing up charts which simulate those derived from written history. Mr. Reeves's book is, however, very useful to the teacher; but it necessarily contains much on which we await further information. By reserving the theromorphs, for example, for the Trias, the author is able to state that the Permian reptiles were not at first clearly differentiated from amphibians. The marvel, however, lies in the rapid rise in Permian times of a mammalo-reptilian type. The hypotheses of the earth's origin do not fit well with tables showing in detail the "periods" of man's occupation of the globe. We have the "solar planetary epoch," the Carboniferous "period," and later the La Tène "period." Unless the geological section is greatly extended, undue emphasis is thrown on the analysis by archaeologists of the progress of early man in the European area. Prof. Sollas's estimates, made in 1909, are wisely taken as a basis for suggesting, by thickness of strata, the relative lengths of geological periods. The author's references to literature should aid the schoolmaster who attempts to deal with man as "a part of Nature." But how are other forms of teaching, in Kentucky, in Middlesex, and elsewhere, to be reconciled with this high ideal?

G. A. J. C.

### Aesthetics.

(1) *Harmonism and Conscious Evolution*. By Sir Charles Walston (Waldstein). Pp. xvi+463. (London: J. Murray, 1922.) 21s. net.

(2) *The Poetic Mind*. By F. C. Prescott. Pp. xx+308. (New York: The Macmillan Co.; London: Macmillan and Co. Ltd., 1922.) 9s. net.

(1) **H**ARMONISM, whatever its attraction as a theory, has chosen very unharmonious terms for its expression. Sir Charles Walston's theory is, in his own words, that conscious evolution in the

human being is due to harmoniotropism rising in its higher stages to aristotropism. "The new born infant," we are told, "emits a first sound or cry which is a spontaneous activity of its vocal chords. From this moment numerous somatocentric and centrobic activities proceed which—unconsciously to the infant itself—establish its relationship to its own functioning body and to the outer world. But with the growth of sentience and nervous activity all the physiological activities of the child are somatocentric, and manifest geometrical or rhythmical regularity, establishing the harmoniotropic tendency and principle of activity."

The book contains a great amount of autobiography and many long extracts from the author's other writings. So far as æsthetics is concerned Sir Charles seems to come nearest to Groos's play theory. He makes no mention of the more recent æsthetic theories, that of Benedetto Croce for example. Art, we are told, is the product of an æsthetic instinct, and we seem to be expected to find the full explanation of it in this description. The purpose of the book is practical, however, rather than theoretical. The idea that inspires the whole scheme is the desire to find a way to reap the full benefit of the awful experience of war and direct to good purpose the agencies, such as the League of Nations, which aim at superseding the conditions which are making strife on the colossal scale a menace to civilisation.

(2) Mr. Prescott's book is a research work in connexion with, or at least undertaken at, Cornell University. It is a laborious attempt to prove a thesis by accumulating examples and illustrations. The thesis is that poetry is a product of the human mind which is to be correlated with dream consciousness. We are thinkers and dreamers. Most of us are both, but in a general way we may class people as one or the other according as imagination or reasoning is their predominant mental activity. It was therefore even more to M. Jourdain's credit than he supposed that he should have been speaking prose all his life. Mr. Prescott is a disciple of Freud and Jung and his thesis is that the dream interpretation of those psychologists is applicable, not merely in general, but in minute detail, to the interpretation of the imaginative content of poetry. It is a thesis which bears very hardly on the poets, and if it is right, they, being dreamers and not thinkers, will find it difficult to put in a defence. Our quarrel, however, is not with his psychology but with his inadequate conception of æsthetics. Poetry is indeed, as Vico was the first to hold, the primitive language, but surely when dreams find expression in poetry they cease to be dreams.

Both these volumes seem to illustrate the impossibility of treating æsthetic subjects without coming to a

clear decision first as to what precisely the æsthetic function is, and second, as to what is the exact relation in which it stands to the logical function. It is no use short-circuiting the inquiry by dismissing æsthetic activity as an instinct, or by degrading it to descriptive psychology. Moreover, the work of Benedetto Croce in this field, open to criticism as it may be, has left research students with no excuse for ignoring the issue. Notwithstanding this defect, each of these books is, in its own way, fresh and original and distinctly stimulating to thought.

### Our Bookshelf.

*A Naturalist in the Great Lakes Region.* By Elliot Rowland Downing. (The University of Chicago Nature-Study Series.) Pp. xxv+328. (Chicago, Ill.: University of Chicago Press, 1922.) 3.50 dollars.

THIS book has been written by a member of the School of Education at Chicago University as one of its nature-study series of handbooks, and it is designed for teachers of nature-study as a guide to the ecology of the country bordering Lake Michigan in the vicinity of Chicago. It is written on ecological lines, and shows abundant evidence of the influence of the American school of ecologists headed by Dr. C. G. Adams and Dr. V. E. Shelford. An account of the geology of the district is given first, followed by a résumé of the geological changes which have led to the present conformation of the country, with special reference to the glacial period and the formation of the basins of the Great Lakes. The animal and plant associations of the district are then dealt with in some detail under the headings: dune, forest, swamp, prairie, and the various aquatic types.

The book is abundantly illustrated by line drawings, which will serve at any rate for a preliminary identification of the animals and plants met with, and a very good series of photographs illustrating the various geological phenomena and biological associations which are described in the text. Many of the maps, however, are too small and so overloaded by unnecessary detail as to render obscure the point they are designed to illustrate. The book will serve admirably the purpose for which it is designed, and should be of the greatest use to teachers and students of Nature in the area with which it deals.

It is evident, however, that the author is not himself familiar with the scientific names of the animals and plants of which he writes. There are dozens of mistakes in the spelling of these names, and if a second edition is called for, the author would do well to enlist the services of a competent zoologist and botanist and submit his scientific names to them for correction. The index, too, shows evidence of hasty compilation. It is neither complete nor accurate. These defects are a serious blot on an otherwise useful book and should be remedied as soon as possible. Fig. 56, too, might usefully be replaced by a series of new and more accurate figures.

*Department of Scientific and Industrial Research.*  
Bulletin No. 6. *On the Electro-Deposition of Iron:*  
With an Appendix containing a bibliography of the  
subject. By W. E. Hughes. Pp. iv + 50. (London:  
H.M. Stationery Office, 1922.) 6s. 6d. net.

THE Department of Scientific and Industrial Research has rendered electrometallurgists signal service by the recent publication of this monograph, written by and containing the results of work by Mr. W. E. Hughes, formerly Chief Research Chemist to the Electrometallurgical Committee of the Ministry of Munitions, and already favourably known for his publications in this particular field. The present brochure contains, within the compass of fifty pages, a systematic study of the effect of current density, temperature, and mechanical movement on the nature of the cathodic deposit of iron formed from ferrous chloride solutions. The deposits were photomicrographed in every case, and the resulting numerous illustrations, excellently reproduced, are of considerable interest.

The view upheld by the author is that the effects of these different factors can all be satisfactorily explained if the formation of a crystalline cathodic metal deposit can be regarded as being governed by conditions similar to those which regulate the nature of a crystalline deposit formed from, say, a molten mass of metal, a fused rock magma, or an aqueous solution. It cannot be said that the view is quite novel. It has certainly been "in the air" for some little time. The striking work of von Weimarn, for example, if considered in connexion with the effect of colloidal additions to an electrolyte on the nature of the cathodic deposit, could not but suggest a close similarity between the nature of the phenomena of electrolytic deposition and precipitation from aqueous solutions. But to Mr. Hughes belongs the credit of stating the analogy in unequivocal language, and of bringing to it a very large measure of experimental support. The variations in crystal structure observed by him are correlated very satisfactorily with changes in the experimental conditions mentioned above, changes which bring about quite similar variations in the nature of crystallisation from other types of systems.

It should be added that an excellent bibliography of the subject is given in the form of an appendix.

*Catalogue of the Fossil Bryozoa (Polyzoa) in the Department of Geology, British Museum (Natural History).*  
*The Cretaceous Bryozoa (Polyzoa).* Vol. 4: *The Cribrimorphs.* Part 2. By Dr. W. D. Lang. Pp. 12 + 404 + 8 plates. (London: British Museum (Natural History), 1922.) 1l. 12s. 6d.

Those who use this volume will bear in mind the illuminating morphological introduction provided by the author in its predecessor (see NATURE, vol. 108, p. 39). The numerous lithographs are from the artistic drawings of Miss G. M. Woodward, and the author again furnishes vigorous text-illustrations showing the specific orthoecia (normal zoecia) and the accompanying aviculæcia, which are the skeletons of the modified polypides that defend the colony. The variety of form, position, and number in the aviculæcia will surprise those who are not specialists. The general

account of the genus *Pelmatopora* (pp. 241-253) is a good example of Dr. Lang's attractive method of dealing with Nature's species-making, here styled "evolutionary activity." In this case the whole of the thirty-eight species are derived from zones in the Senonian.  
G. A. J. C.

*Pope's Manual of Nursing Procedure.* By Amy E. Pope. Pp. xi + 596. (New York and London: G. P. Putnam's Sons, 1919.) Price 15s.

THIS book has been prepared more especially to facilitate practical instruction in the work usually included in the probationer's first year of training. In each section a consideration of the principles underlying the various nursing procedures is followed by a description of demonstrations of the methods involved. In this way, and with frequent reference to physiology, the author associates theory with practice.

There are a few errors and omissions; in the description of Fowler's position, a right angle is represented diagrammatically and in the text as  $100^\circ$ ; and in the list of prescription abbreviations and symbols no mention is made of the commonest in use, that for "thrice daily." The use of more illustrations would enable a reduction to be made in the length of descriptions of technique. The book is more suitable for the guidance of the instructor than as a manual for the probationer.

*Précis d'Arithmétique.* Par J. Poirée. Pp. x+63. (Paris: Gauthier-Villars et Cie, 1921.) 7-50 francs.

M. POIRÉE has not written a book on arithmetic in the sense of a school text-book: it can be more accurately described as an introduction to the theory of arithmetic. Although the author sets out with care and precision the main ideas underlying arithmetical processes—"the why and the mechanism of each operation"—yet there is no attempt made to teach the subject. The book is very interesting—is there a French book on mathematics that does not make pleasant reading? A quarter of the space is devoted to the fundamental theorems of the theory of numbers, and in fact all through the book there is an evident suggestion that the author is aiming at the theory of numbers. Numerical illustrations of the processes are given, but there are no exercises for the student to work out himself.  
S. B.

*Practical Physics.* By W. R. Bower and Prof. J. Satterly. Eighth impression (second edition). Pp. xi + 422. (London: University Tutorial Press, Ltd., 1922.) 7s.

A DISTINCTIVE feature of this text-book of practical physics is the inclusion of a considerable number of experiments which may be performed by the student at home, using very simple apparatus. In the second edition a supplement has been added containing a number of additional experiments. These are concerned with Fletcher's trolley apparatus, coefficients of friction, Mariotte's bottle, surface tension, expansion of solids, thermal conductivity, photometers, and critical angles. The importance of avoiding eyestrain has not been sufficiently considered in the mathematical tables at the end of the volume.

### Letters to the Editor.

*The Editor does not hold himself responsible for opinions expressed by his correspondents. Neither can he undertake to return, or to correspond with the writers of, rejected manuscripts intended for this or any other part of NATURE. No notice is taken of anonymous communications.*

#### Relativity and the Æther.

WHILE at Brighton recently I visited its excellent Public Library, and there found the three supplementary volumes of the "Ency. Brit." containing the remarkably lucid article on relativity by Dr. Jeans. Many have written and multitudes have read about this subject, but I venture to say that nowhere can be found a more compact and accurate presentation of the strict relativist position. There is nothing anæmic or half-hearted about it; and I imagine that while non-physicists will find the article readable, most physicists will find its crisp clearness instructive. Very little can a pragmatic or anti-philosophic relativist like myself find to disagree with in it, and where I do disagree it is just possible that both or neither may be right.

Still I do want to quote and criticise one clear and definite sentence; into which I insert only references to my comments which follow, so as not to spoil it.

On the electromagnetic theory of Faraday and Maxwell, waves of light "were simply waves in the æther and travelled with an absolute velocity  $c$  determined once and for all by the structure of the æther. (1) On this view it was quite certain (2) that an observer moving through the æther with a velocity  $u$  would measure the velocity of light travelling in the same direction as himself as  $c-u$ . Relativity teaches (3) that this velocity is always precisely  $c$ , and this in itself disposes (4) of the æther of Faraday and Maxwell."

On this pronouncement I comment thus:—

(1) That is certainly true.

(2) Not quite certain. It might have been thought certain; but the FitzGerald contraction is an indication of unexpected possibilities in the instruments of measure. Still, no first order loophole has been suggested, and the challenge is a legitimate one. Would that the experiment could be tried! I assume that every one will agree that it has not yet been tried, and that it is difficult to devise a sure and certain way.

(3) It certainly and very forcibly does so teach.

(4) But a hypothesis, even the foundation hypothesis of a developed theory, cannot logically be cited as if it were an experimentally ascertained and conclusive fact; nor can it be used to give a knock-out blow to another theory. Opposing theories still have to fight it out. Full-blown Relativity might equally well be said to dispose of Matter, by reducing it to the unevenness of a field, or to the tensor  $-8\pi T_{\mu\nu}$ , or to an algebraic expression like  $G_{\mu\nu} - \frac{1}{2}g_{\mu\nu}G$ , which apparently is conserved like matter, is obedient to our laws of motion, and vanishes in what we call empty space.

I do not think that even Dr. Jeans will claim that there is any ascertained fact to substantiate what I have marked as (3). It all depends upon  $ux/c^2$  and differing estimates of time.

It may be said that conclusions of relativity have been verified, and that thus the theory is established. I should prefer to say that some mathematical deductions arrived at by the relativity method have been brilliantly verified, and hence that the method has pragmatically been proved to be sound. I should

not say that its philosophic foundations were established; still less that they have rendered all other foundations rotten.

It would seem rather that more than one mode of expression is possible for even the simplest fact, and that a criterion of absolute and exclusive truth in any statement is increasingly difficult to find. A theory which renders it uncertain whether the Fire of London preceded or succeeded the outburst of Nova Persei, whether the sun revolves round the earth or *vice versa*, and whether a much-travelled man's death preceded his birth, should not be too positive when it leaves its own realm and enters the region of fact and reality, whatever those possibly question-begging terms may mean. Perhaps there is no absolute truth. More probably absolute truth exists, but is not easy to arrive at.

Meanwhile we may be grateful that, thanks to the new school, we are beginning to recognise the uncertainty and contingency inseparable from all forms of human statement. Let our geniuses not extinguish but supplement each other. There is room not only for Einstein and Weyl but also for Newton and Maxwell. The reconciliation may not be obvious, the connecting passage is difficult to find, but it would be wise to keep the door ajar.

OLIVER LODGE.

#### The Legal Equivalent of the Metre.

MAY I correct in NATURE an unfortunate error which occurs on p. 580 of the "Dictionary of Applied Physics"? It is there stated that the equivalent of the metre in inches is 39.37008, and the Order in Council of May 19, 1898, is referred to as giving the legalised value of this quantity. The information was taken, by permission, from the "Computer's Handbook," issued by the Meteorological Office in 1921, and the inference is that the above figure is the legalised value.

Dr. Stratton, of the United States Bureau of Standards, recently directed my attention to the error. The legalised value given in the Order of Council is 39.370113 inches.

The "Computer's Handbook" states that: "The most recent values for the metrical equivalent of the fundamental British Units are those contained in the Order of Council of 19th May 1898," and, after a reference to earlier editions of the "Handbook," continues: "Values in accordance with the Order in Council of 1898 have now been substituted."

I assumed this to mean that the actual legalised values had been used and printed the figures without further verification, but this is not the case.

The figure given—39.37008—is deduced from the relation 1 inch = 25.4 millimetres; the legalised value of the inch in millimetres is 25.399978. The difference, less than one part in a million, is negligible for nearly all purposes and there would be many advantages in accepting, as the legalised ratio, 1 inch = 25.4 millimetres, but this has not been done.

At present some confusion may easily arise; for in America the ratio 1 metre = 39.370000 inches has been adopted.

We thus have the equivalents given in the following table:

	Metre in Inches.	Inches in Millimetres.
America . . . . .	39.370000	25.400051
"Computer's Handbook" . . . . .	39.37008	25.40000
British Legalised Value . . . . .	39.370113	25.399978



The matter is discussed in an article on metrology, by Mr. Sears, which will appear in the forthcoming volume of the "Dictionary of Applied Physics."

R. T. GLAZEBROOK.

Coton End, 63 Grange Road, Cambridge,  
September 9.

### On the Reality of Nerve-Energy.

IF I have understood Prof. Fraser Harris's letter in *NATURE* of September 9, p. 342, it is a plea for the more widespread use of the term "nerve-energy" by physiologists and for the investigation of it as a special manifestation of energy like heat, light, or electricity. It is no doubt quite true that the term has a definite and useful meaning in psychology and psycho-pathology, though "mental energy" would probably do as well in most cases.

As a physiological concept, however, "nerve-energy" has little to recommend it. Some idea of the difficulties which are likely to attend its use may be seen even in Prof. Harris's letter; moreover, there is very little need to postulate a special kind of energy to explain the nervous impulse and its conduction, for of all the different activities of living cells that of conduction can be most readily described in terms of physics and chemistry.

The momentary change which makes the nervous impulse seems to consist in a depolarisation of the surface layers of the nerve fibre, a resulting increase in permeability, and an escape of ions from the interior of the fibre. The movement of ions brings about an increase of permeability in further sections of the fibre and a decrease in the sections previously active, so that the disturbance spreads but does not last for more than a brief time at any one point. The process is so simple in its essentials that Prof. Lillie has been able to construct model nerve fibres of iron wires coated with a film of passive iron and immersed in nitric acid. These models copy the behaviour of a nerve fibre with surprising fidelity.

For some time past, evidence has accumulated in favour of this explanation; it would be quite misleading to suggest that every detail of the conduction of the impulse is understood, but the broad outlines of the "membrane theory" have not been seriously challenged. The energetics of the process were worked out by Bernstein. The system loses free energy when the ions escape from regions of high to regions of low concentration, and ultimately this must be replaced by the metabolism of foodstuffs in the fibre. The splitting up of a large molecule into a number of smaller ones would suffice to restore the concentration differences upon which the movement of ions depends, and at various stages heat may be given out or absorbed from the surroundings. In no part of this scheme is there any need, or any opportunity, for the introduction of a special form of energy peculiar to nerves.

If the term "nerve-energy" is to be retained it might be used to mean the total potential energy in the neurone available for use in the transmission of impulses, but it is doubtful whether much would be gained by the measurement of this quantity. Prof. A. V. Hill has shown that the energy expended in the passage of a single impulse is extremely small, and the neurone is able to replenish its stores continually from the nutrient fluids which surround it. When failure of conduction occurs it seems to be due more often to a failure of the surface reaction than to an exhaustion of the store of potential energy in the fibre.

E. D. ADRIAN.

Trinity College, Cambridge.

NO. 2761, VOL. 110]

### Interspecific Sterility.

IN his letter on this subject (*September 2*, p. 312), Mr. Harrison states some interesting facts regarding the chromosome numbers in *Salix*. This appears to be the first case in plants where tetraploidy is accompanied by very little external change. Both tetraploid and hexaploid numbers in a genus have long been known, for example in *Musa*, but the point of my remark regarding interspecific sterility in crosses between diploid and tetraploid forms appears to have been missed. It is not that there is any difficulty in making such crosses in the first place. Usually they are easily made, but the result is a triploid form with an unstable chromosome content.

If such crosses between a diploid and a tetraploid species occur in *Nature*, they cannot lead to a permanent, stable form, except by apogamous reproduction. The hybrid may cross back with either parent, but this leads again to new and irregular chromosome numbers, with the result that, in the absence of apogamy, stability will be reached only when the extra chromosomes have been lost and the number has reverted to the diploid, or possibly in some cases to a balanced intermediate number. The two parental species, respectively diploid and tetraploid, will in the meantime each have carried on its own line of descent.

It follows that if a tetraploid form arises from a diploid species in *Nature*, it will continue to breed true, while its hybrids with the parent species will not give rise to a permanent line of descent unless there is apogamous reproduction. This is, for practical purposes, a condition of physiological isolation. *Spiranthes cernua* is a probable example of this sort, and there are many others. Once two such independent lines of descent are established, the divergence between them may go on increasing as fresh variations occur in each series.

K. RUGGLES GATES.

King's College, London.

### Micro-Chemical Methods in the Practical Teaching of Chemistry.

IN view of the strenuous efforts now being made by educational authorities in this country to economise on educational expenditure, considerable interest attaches to Prof. Egerton Grey's letter on the application of micro-chemical methods in the teaching of chemistry (*NATURE*, September 2, p. 309). During the War we conducted a course of practical instruction in chemistry in the Internment Camp for Civilian Prisoners of War in Ruhleben, and the difficulty of procuring large quantities of reagents led to the adoption of "Micro" methods wherever possible. Although we had at times forty students preparing for university examinations, the consumption of chemical reagents was extremely small in comparison with what would be required in the ordinary way. To give just one example, half a litre of nitric acid—a precious liquid in the camp—was found sufficient to supply the needs of these students for several months. One enterprising student fitted for himself a fully equipped "micro" laboratory in a tiny corner of his loft and undertook interesting research work.

A further advantage of the method is that the quantities involved are so small that the students can study the chemical properties of many of the rarer elements with great advantage to themselves and small expense to the laboratory. We are in hearty agreement with Prof. Grey as to the economic and educational advantages of the micro-chemical methods.

J. W. BLAGDEN.

A. WECHSLER.

## The Progression of Life in the Sea.<sup>1</sup>

By E. J. ALLEN, D.Sc., F.R.S.

DIFFERENT views are still held as to where life in the world had its origin, but no one questions that it began in close connexion with water. That it began in the sea, where the necessary elements were present in appropriate concentrations and in an ionised state, is an idea which appeals to many with increasing force the more closely it is examined. This view has been developed recently by Church<sup>2</sup> in his memoir on "The Building of an Autotrophic Flagellate," in which he boldly attempts to trace the progression from the inorganic elements present in sea-water to the unicellular flagellate in the plankton phase, floating freely in the water. The autotrophic flagellate, manufacturing its own food, he regards as the starting-point from which all other organisms, both plants and animals, have sprung. To understand the first step in this progression, the passage from the dead inorganic to the living organic remains, is as it has always been, one of the great goals of science, not of biological science alone, but of all science. Recent research has, I think, thrown much light on the fundamental problems involved. In a paper published last year, Baly, Heilbron, and Barker,<sup>3</sup> extending and correcting previous work by Benjamin Moore and Webster,<sup>4</sup> have shown that light of very short wave-length ( $\lambda = 200 \mu\mu$ ), obtained from a mercury-vapour lamp, acting upon water and carbon dioxide alone, is capable of producing formaldehyde, with liberation of free oxygen. Light of a somewhat longer wave-length ( $\lambda = 290 \mu\mu$ ) causes the molecules of formaldehyde to unite or polymerise to form simple sugars, six molecules of formaldehyde, for example, uniting to form hexose. The arresting fact brought out in these researches is that the reactions take place, under the influence of light of appropriate wave-lengths, without the help of any catalyst, either organic or inorganic. Where a source of light is used which furnishes rays of many wave-lengths, the simple reaction of the formation of formaldehyde is masked by the immediate condensation of the formaldehyde to sugar, but this can be prevented by adding to the solution a substance which absorbs the longer wave-lengths, so that only the short ones which produce formaldehyde are able to act.

When the formation of sugars is postulated, the introduction of nitrogen into the organic molecule offers little theoretical difficulty; for not only has Moore<sup>5</sup> shown that nitrates are converted into the more chemically active nitrites under the influence of light of short wave-length, but he maintains that marine algae, as well as other green plants, can, under the same influence, assimilate free nitrogen from the air. Baly<sup>6</sup> also has succeeded in bringing about the union of nitrites with active formaldehyde in ordinary test-tubes by subjecting the mixture to the light of a quartz-mercury lamp.

If these results of the pure chemist are justified, they go far towards bridging the gap which has separated the inorganic from the organic, and make it not too presumptuous to hazard the old guess that even to-day it is possible that organic matter may be produced in the sea and other natural waters without the intervention of living organisms. We may note here, too, that if we take account of only the most accurate and adequately careful work, the actual experimental evidence at the present time requires the presence of a certain amount of organic matter in the culture medium or environment before the healthy growth of even the simplest vegetable organism can take place.

Let us then assume that we are allowed to postulate in primitive sea-water or other natural water organic compounds formed by the energy of light vibrations from ions present in the water, and see how we may proceed to picture the building up of elementary organisms. Without doubt the evolutionary step is a long and elaborate one, for even the simplest living organism is already highly complex both in structure and function. As the molecules grew more complex by the progressive linkage of the carbon atoms of newly formed carbohydrate and nitrogenous groups, we must suppose that the organic substance, for purely physical reasons, assumed the colloidal state, and at the same time its surface-tension became somewhat different from that of the surrounding water. With the assumption of the colloidal state, the electric charges on the colloidal particles would produce the effect of adsorption and fresh ions would be attracted from the surrounding medium, producing a kind of growth entirely physical in character. We thus arrive at the conception of a mass of colloidal plasma differing in surface-tension from the water and increasing in size by two processes, one chemical, due to linkage of carbon atoms; the other physical, brought about by the adsorption of ions by the colloidal particles.

The difference of surface-tension would tend to make the surface a minimum and the shape of the mass spherical. On the other hand, maximum growth would demand maximum exchange with the surrounding medium, and hence maximum surface. From the antagonism of these two factors, surface-tension and growth, there would follow, first, the breaking up of the mass into minute particles upon the slightest agitation, and, secondly, changes of form wherever growth involved local alterations of surface-tension; the latter would represent the first indication of the property of contractility.

So far we have considered only the process of the building up of the elementary plasmic particles, the anabolic process. Church, whose memoir already referred to I am now closely following, points out that these anabolic operations must from the beginning have been subject to the alternations of day and night, for during the night the supply of external energy is removed. "If during the night," he asks, "the machine runs down, to what extent may it be possible so to delay the onset of molecular finality that some reaction may continue, at a lower rate, until the succeeding day?" And his answer is: "The suc-

<sup>1</sup> From the presidential address delivered to Section D (Zoology) of the British Association at Hull on Sept. 8.

<sup>2</sup> "Biological Memoirs," I, Oxford, 1919.

<sup>3</sup> Journ. Chem. Soc., London, vols. 119 and 120, 1921, p. 1025. NATURE, vol. 109, 1922, p. 341.

<sup>4</sup> Proc. Roy. Soc. B., vol. 87, p. 163 (1913), p. 556 (1914); vol. 90, p. 168

(1915), p. 169 (1916); Rev. Soc. B., vol. 90, p. 158 (1918); vol. 92, p. 51 (1921).

<sup>6</sup> Baly, Heilbron and Hudson, Journ. Chem. Soc., London, vols. 121 and 122, 1922, p. 1078.

cessful solution of this problem is defined physiologically by the introduction of the conception 'katabolism,' as implying that energy derived from the 'breaking down' of the plasma itself . . . may be regarded as a 'secondary engine,' functional in the absence of light, and evolved as a last resort in failing plasma." Katabolism persists as the ultimate mechanism in the physiology of animal as contrasted with plant life, but if the suggestion just quoted is sound it originated, as the first "adaptation" of the organism, to meet the factor of recurring night and day. That the problem was successfully solved we know, but as to the mechanism of its solution we have no key. It is at this point, again to use Church's words, that the "plasma, previously within the connotation of chemical proteid matter, becomes an autotrophic, increasingly self-regulated, and so far individualised entity, to which the term 'life' is applied."

The elementary plasma is thus now fairly launched as an individual living organism, and the great fundamental problems of biology—memory, heredity, variation, adaptation—face us at each step of our further progress. We see in broad outline the conditions the advancing organism had to meet, we see the means by which those conditions were in fact met, we know that only those individuals survived which were able to meet them. Further than this we, the biologists of to-day, have not advanced. The younger generation will pursue the quest, and, with patient effort, much that now lies hidden will grow clear.

The differentiation of the growing particles of plasma into definite layers, which followed, seems natural; first the external layer, in molecular contact with the surrounding water, from which it receives substances from outside in the form of ions, and to which it itself gives off ions; beneath this the autotrophic layer to which light penetrates, and in which, under the influence of the light, new organic substance is built up; in the centre a layer to which light no longer penetrates. This central region, the nucleus, depends entirely on the peripheral layers for its own nutrition, and becomes itself concerned only with katabolic processes, those processes of the organism which depend upon the breaking down, and not the building up, of organic substance.

At an early stage in the development of the individual organism the spherical shape, which the organic plasma was compelled to assume under the influence of surface-tension, underwent an important modification, the effect of which has impressed itself upon all later developments. A spherical organism floating in the water and growing under the direct influence of light would obviously grow more rapidly on the upper side, where the light first strikes it, than it would on the lower side away from the light. There followed, therefore, an elongation of the sphere in the vertical direction, and the definite establishment of an anterior end, the upper end which lay towards the light and at which the most vigorous growth took place. In this way there was established a definite polarity, which has persisted in all higher organisms, a distinction between an anterior and a posterior end. With the concentration of organic substance which took the form of nucleus and reserve food supply, the specific gravity of the plasma would become greater

than that of the surrounding water and the organism would tend to sink. The necessity, therefore, arose for some means of keeping it near the surface, that it might continue to grow under the influence of light. The response to this need, however it was attained, came in the development of an anterior flagellum. This we may regard as an elongation in the direction of the light of a contractile portion of the external layer, moving rhythmically, which by its movement counteracted the action of gravity, and acting as a tractor drew the primitive flagellate upwards towards the surface layers, into a position where further growth was possible. With the establishment of the flagellum an organ is produced which shows remarkable persistence in both the animal and vegetable kingdoms, and from the existence of the flagellated spermatozoon in the higher vertebrates, in accordance with Haeckel's biogenetic law that the individual in its development repeats or recapitulates the history of the race, we conclude that they also in their earliest history passed through a plankton flagellate phase.

Exactly at what stage in the history of the autotrophic flagellate the first formation of chlorophyll and its allied pigments took place we have no means of determining, but it may have been before even the flagellum itself had begun. This advance and the subsequent concentration of the pigments into definite chromatophores or chloroplasts doubtless increased immensely the efficiency of the organism in producing the food which was necessary to it. The recent work of Baly and his collaborators becomes here again of the first importance, and though the subject of the part played by chlorophyll in photosynthesis belongs rather to botany and chemistry than to zoology, I may perhaps, for the sake of completeness, be allowed to refer to it very briefly. I have already said that Baly brought about the synthesis of formaldehyde from carbon dioxide and water under the influence of rays of very short wave-length ( $\lambda = 200\mu$ ) from a mercury-vapour lamp. He was also able to show that when certain coloured substances were added to the solution of carbon dioxide in water the same reaction took place under the influence of ordinary visible light. His explanation of this process is that the coloured substance known as the photocatalyst absorbs the light rays and then itself radiates, at a lower infrared frequency corresponding to its own molecular frequency, the energy it has absorbed. At this lower frequency the energy thus radiated is able to activate the carbonic acid, so that the reaction leading to the formation of formaldehyde can and does take place. In the living plant this synthesised formaldehyde probably polymerises at once to form sugars.

Malachite green and methyl orange, as well as other organic compounds, were found to act as photocatalysts capable of synthesising formaldehyde, and Moore and Webster's work had previously shown that inorganic substances, such as colloidal uranium oxide and colloidal ferric oxide, can do the same. Chlorophyll in living plants may with some confidence be assumed to operate in a similar way, though no doubt the series of events is more complex, since the green pigment itself is not a single pigment, and others, such as carotin and xanthophyll, are also concerned.

We have tried to picture the gradual building up

from elements occurring in sea-water of a chlorophyll-bearing flagellate, capable of manufacturing its own nourishment and able to multiply indefinitely by the simple process of dividing in two. If we assume only one division during each night as a result of the day's work in accumulating food material, such an organism would be able in a comparatively short space of time to occupy all the natural waters of the world. But here we are met by a difficulty which is not easily overcome. Chlorophyll, the photocatalyst, the most essential factor in the building up of the new organic matter, is itself a highly complex organic substance, and in any satisfactory theory its original formation and its constant increase in quantity must be accounted for. Lankester<sup>7</sup> has maintained that chlorophyll must have originated at a somewhat late stage in the development of organic life, and has suggested that earlier organisms may have nourished themselves like animals on organic matter already existing in a non-living state. An alternative hypothesis, which in view of the recent work seems more attractive, is to suppose that the earlier organisms were either activated by some simpler photocatalyst, or that they received the necessary energy at suitable frequency directly from some outside source.

It must not be forgotten, also, that at the time these developments were taking place the conditions of the environment would in many ways have been different from those now existing in the sea. One suggestion of special interest that has been made<sup>8</sup> is that the concentration of carbon dioxide in the atmosphere, and hence also in natural waters, was very much greater than it is to-day. Free oxygen, indeed, may have been entirely absent, and all the free oxygen now present in the air may owe its existence to the subsequent splitting up of carbon dioxide by the action of plant life. With such possibilities of differences in the conditions in this and in so many other directions, may we not be well satisfied if, for the time, we can say that the formation of carbohydrates and proteids has been brought within the category of ordinary chemical operations, which can occur without the previous existence of living substance?

To return once more, however, to the free-swimming, autotrophic flagellate. In the early stages of its history the loss caused by sinking, and so getting below the influence of light and the possibility of further growth, must have been enormous. We may conceive a constant rain of dead and dying organisms falling into the darker regions of the sea, and thus a new field would be offered for the development of any slight advantages which particular individuals might possess. Under such conditions we may suppose that the holozoic or animal mode of nutrition first began in the absorption of one individual by another one, with which it had chanced to come into contact. If the one individual were more vigorous and the other moribund we should designate the process "feeding," and the additional energy obtained from the food might well cause the individual to survive. If the two individuals which coalesced were both sinking from loss of vigour, the combined energy

of the two might make possible a return to the upper water layers, where, under the influence of light, growth and multiplication would proceed, and we should, I suppose, designate the coalescence "conjugation," or sexual fusion.

Other individuals, again, sinking in shallow water, would stick to solid objects on the sea-floor, while the flagellum continued to vibrate. The current produced by the flagellum under these conditions would draw towards the organism dead and disintegrating remains of its fellows, and again we should have ingestion and animal nutrition. At this stage we witness the definite passage from plant to animal life. A further stage is seen when a cup-like depression to receive the incoming particles of food is formed at the base of the flagellum, to be followed still later by a definite mouth.

The transformation from the plant to the animal mode of feeding can be seen in action by studying actual organisms which exist to-day. In the course of my work on the culture of plankton organisms there has flourished in the flasks, on several occasions, a small flagellate belonging to the group of chryso-monads, which was first described by Wysotzky under the name of *Pedinella hexacostata*, and to which I directed the attention of Section D at the Cardiff Meeting in 1920. The general form of *Pedinella* resembles that of the common *Vorticella*, but its size is much smaller. The body, which is only about  $5\mu$  in diameter, is shaped like the bowl of a wine-glass, and from the base of the bowl, which is the posterior end, a short, stiff stalk extends. From the centre of the anterior surface there arises a single long flagellum, surrounded at a little distance by a circle of short, stiff, protoplasmic hairs. Arranged in an equatorial ring just inside the body are six or eight brownish-green chromatophores or chloroplasts. In a healthy culture *Pedinella* swims about freely by means of a spiral movement of the flagellum, which functions as a tractor, the stalk trailing behind. The chromatophores are large, brightly coloured, and well developed, and the organism is obviously nourishing itself after the manner of a plant, like any other chryso-monad. But from time to time a *Pedinella* will suddenly fix itself by the point of the trailing stalk. The immediate effect of this fixing is that a current of water, produced by the still vibrating flagellum, streams towards the anterior surface of the body, and small particles in the water, such as bacteria, become caught up on the anterior surface, the ring of fine stiff hairs surrounding the base of the flagellum being doubtless of great assistance in the capture of this food. One can clearly see bacteria and small fragments of similar size engulfed by the protoplasm of the anterior face of the *Pedinella* and taken into the body. The organism is now feeding as an animal. In some of the cultures in which bacteria were very plentiful nearly all the *Pedinella* remained fixed and fed in the animal way, and when this was so the chromatophores had almost disappeared, though they could still be seen as minute dark dots. We can, as it were, in this one organism, see the transition from plant to animal brought about by the simple process of the freely swimming form becoming fixed.

In the group of dinoflagellates, also—the group to which the naked and armoured peridinians belong—

<sup>7</sup> Treatise on Zoology, Part I., Introduction. London, 1909.  
<sup>8</sup> Carl Snyder, "Life without Oxygen," *Science Progress*, vol. vi., 1912, p. 107.

the same transition from plant to animal nutrition can be well followed by studying different members of the group. In heavily armoured forms, with a rich supply of chromatophores, nutrition is chiefly plant-like or holophytic. In those with fewer chromatophores there is, on the other hand, often distinct evidence of the ingestion of other organisms, and nutrition becomes partly animal-like. Among the naked dinoflagellates such holozoic nutrition is very much developed, and in many species has superseded entirely the earlier method of carbonic acid assimilation.

It is surprising how many structural features found in higher groups of animals make their first appearance in these naked dinoflagellates in conjunction with this change of nutrition, and we seem to be led directly to the metazoa, especially to the cœlenterata. In *Polykrikos* there are well-developed stinging cells or nematocysts, as elaborately formed as those of *Hydra* or the anemones. In *Pouchetia* and *Erythropis* well-developed ocelli are found, consisting of a refractive, hyaline, sometimes spherical lens, surrounded by an inner core of red pigment and an outer layer of black; the whole structure is comparable to the ocelli around the bell of a medusa. In *Noctiluca* and in the allied genus *Pavillardia* a mobile tentacle, which is doubtless used for the capture of food, is developed. Division of the nucleus, with the formation of large, distinct chromosomes, has also been described in several of these dinoflagellates. With the tendency of the cells in certain species to hold together after division and form definite chains we seem to approach still nearer to the metazoa, until, finally, in *Polykrikos* we reach an organism which may well have given rise to a simple, pelagic cœlenterate. It is difficult to resist the suggestion put forward by Kofoid<sup>9</sup> in his recent monograph, that if to *Polykrikos*, with its continuous longitudinal groove which serves it as a mouth, its multicellular and multinucleate body and its nematocysts, we could add the tentacle of *Noctiluca*, and perhaps also the ocellus of *Erythropis*, "we should have an organism whose structure would appear prophetic of the cœlenterata and one whose affinities to that phylum and to the dinoflagellata would be patent." Or it may be that the older view is the correct one here, and that the first cœlenterate came from a spherical colony of simple holozoic flagellates, arranged something on the plan of *Volvox*, in which the posterior cells of the swimming colony, in the wake of which food particles would collect, had become more specialised for nutrition than the rest.

As a purely plankton organism, swimming freely in the water, the progress of the cœlenterate was not great, and reached, so far as we know, no further than the modern ctenophore. The ctenophore seems to represent the culminating point of the primary progression of pelagic animals, which derived directly from the autotrophic flagellate. Further evolution was associated with an abandonment of the pelagic habit by a cœlenterate-like animal, and the establishment of a connexion with the sea-bottom, either by fixing to it, by burrowing in it, or by creeping or running over it. At a later stage many of the animals which

had become adapted to these modes of life developed new powers of swimming, and thus gave rise to the varied pelagic life which we find in the sea to-day; but this must be regarded as secondary, the primary pelagic life, so far as adult animals were concerned, having ended with the evolution of the ctenophore.<sup>10</sup> Such is the teaching of embryology, the history of the race being conjectured from the development of the individual. In group after group of the animal kingdom, when the details of its embryology become known, the indications are the same—first the active spermatozoon, reminiscent of the plankton flagellate, then the pelagic larval stage, recalling the cœlenterate, and then a bottom-living phase.

It is in a ctenophore-like ancestor that we find the line of development to higher animal groups, and this ancestor must have been at one time widely distributed in the seas. Its immediate descendants are familiar to every zoological student in the well-known series of pelagic larval forms. Müller's larva, taking to the bottom, and in its hunt for food gliding over hard surfaces with its cilia, led to the flatworms; the *Pilidium*, developing a thread-like body and creeping into cracks and crevices to transfix its prey, gave rise to the nemertines. A trochophore, burrowing in soft mud and sand, developed a segmented body which gave it later the power of running on these soft surfaces, and became an annelid worm. Another trochophore, developing a broad, muscular foot, crept on the sand, and afterwards buried itself beneath it as a lamellibranchiate mollusc, or migrated on to harder surfaces as the gastropod and its allies. *Pluteus*, *Bipinnaria*, *Auricularia*, first fixing, as the crinoids still do, and developing a radial symmetry, afterwards broke free and wandered on the bottom as sea-urchin, star-fish, and cucumarian. *Tornaria* developed into *Balanoglossus*, the structure of which hints to us that the ascidians and vertebrates came from a similar stock. All the phyla thus represented derive directly from the free-swimming ctenophore-like ancestor, and only one considerable group, the arthropods, remains unaccounted for. The evolutionary history of an arthropod is, however, not in doubt. Its marine representatives, the trilobites and Crustacea, came directly from annelids, which, after their desertion of a pelagic life to burrow in the sea-floor and run along its surface, again took to swimming, and not only stocked the whole mass of the water with a rich and varied life of copepods, Cladocera, and schizopods, but gave rise to amphipods, isopods, and decapods, groups equally at home when roaming on the bottom or swimming above it.

Another important addition to the pelagic fauna we should also notice here. From the molluscs, creeping on solid surfaces, sprang a group of swimmers, the cephalopods, which have grown to sizes almost unequalled amongst the animals of the sea.

All these invertebrate phyla had become established and most of them had reached a high degree of development in the seas of Cambrian times. Among animals then living there are many which have survived with little change of form until to-day. One is almost tempted to suggest that the life which the sea itself

<sup>9</sup> Kofoid and Swezy, "The Free-living Unarmoured Dinoflagellata." Mem. Univ. California, 1921.

<sup>10</sup> There is perhaps a possibility that further knowledge of the embryology of *Sagitta* and its allies might make it necessary to modify this suggestion.

could produce was then reaching its summit and becoming stabilised. Since Cambrian times geologists tell us some thirty million years<sup>11</sup> have passed, a stretch of time which it is really difficult for our imaginations to picture. During that time a change of immense moment has happened to the life of the sea; but if we read the signs aright, that change had its origin rather in an invasion from without than in an evolution from within. From whence came that tribe of fishes which now dominates the fauna of the sea? It would be rash to say that we can give any but a speculative reply to the question, but the probable answer seems to be that fishes were first evolved not to meet conditions found in the sea, but to battle with the swift currents of rivers, where fishes almost alone of moving animals can to this day maintain themselves and avoid being swept helplessly away.<sup>12</sup> It was in response to these conditions that elongate, soft-bodied creatures, which had penetrated to the river mouth, developed the slender, stream-lined shape, the rigid yet flexible muscular body, the special provision for the supply of oxygen to the blood to maintain an abundant stock of energy, and all those minute perfections for effective swimming that a fish's body shows. The fact that many sea fishes still return to the rivers, especially for spawning, supports this view, and it is in accordance with Traquair's classical discoveries of the early fishes of the Scottish Old Red Sandstone, which were for the most part fresh- and brackish-water kinds.

Having developed, under the fierce conditions of the river, their speed-and-strength as swimmers, the fishes returned to the sea, where their new-found powers enabled them to roam over wide areas in search of food, and gave them such an advantage in attack and defence that they became the predominant inhabitants of all the coastal waters, and as such they remain to-day.

The other great migration of the fishes, also, the migration from the water to the land, giving rise to amphibians, reptiles, birds and mammals, must not be left out of account. - The whales, seals, and sea-birds which, after developing on land, returned again to the waters and became readapted for life in them, are features which cannot be neglected.

And so we are brought to the picture of life in the sea as we find it to-day. The primary production of organic substance by the utilisation of the energy of sunlight in the bodies of minute unicellular plants, floating freely in the water, remains, as it was in the earliest times, the feature of fundamental importance. The conditions which control this production are now, many of them, known. Those of chief importance are (1) the amount of light which enters the water, an amount which varies with the length of the day, the altitude of the sun, and the clearness of the air and of the water; (2) the presence in adequate quantity of mineral food substances, especially nitrates and phosphates; and (3) a temperature favourable to the growth of the species which are present in the water at the time. Experiments with cultures of diatoms have shown clearly that if the food-salts required are present, and the conditions as to light and temperature are satisfactory, other factors, such as the salinity of the water and the pro-

portions of its constituent salts, can be varied within very wide limits without checking growth. The increased abundance of plankton, especially of diatom and peridinium plankton, in coastal waters and in shallow seas largely surrounded by land, such as the North Sea, is due to the supply of nutrient salts washed directly from the land by rain or brought down by rivers. An exceptional abundance of plankton in particular localities, which produces an exceptional abundance of all animal life, is also often found where there is an upwelling of water from the bottom layers of the sea. These conditions are met with where a strong current strikes a submerged bank, or where two currents meet. Food-salts which had accumulated in the depths, where they could not be used owing to lack of light, are brought by the upwelling water to the surface and become available for plant growth. The remarkable richness of fish life in such places as the banks of Newfoundland and the Agulhas Banks off the South African coast, each of which is the meeting-place of two great currents, is to be explained in this way.

Attention has already been directed to the suggestion that fishes developed their remarkable swimming powers in rivers in response to a need to overcome the currents, and that they returned afterwards to the sea, where they preyed upon a well-developed and highly complex invertebrate fauna already fully established there. Their speed enabled them to conquer their more sluggish predecessors, while they themselves were little open to attack. With the exception of the larger cephalopods, which are of comparatively recent origin, and were probably evolved after the arrival of the fishes, there are few, if any, invertebrates which capture adult fishes as part of their normal food. Destructive enemies appeared later in the form of whales and seals and sea-birds, which had developed on the land and in the air.

And now in these last days a new attack is made on the fishes of the sea, for man has entered into the struggle. He came first with a spear in his hand; then, sitting on a rock, he dangled a baited hook, a hook perhaps made from a twig of thorn bush, such as is used to this day in villages on our own east coast. Afterwards, greatly daring, he sat astride a log, with his legs paddled further from the shore, and got more fish. He made nets and surrounded the shoals. Were there time we might trace step by step the evolution of the art of fishing and of the art of seamanship, for the two were bound up together, till the day when the trawlers and drifters kept the seas for the battle fleet.

There can be little doubt that in European seas the attack on the fishes in the narrow strip of coastal water where they congregate has become serious. A considerable proportion of the fish population is removed each year, and human activity contributes little or nothing to compensate the loss. We have not, however, to fear the practical extinction of any species of fish, the kind of extinction that has taken place with seals and whales. Fishing is subject to many natural limitations, and when fishing is suspended recovery will be rapid. There is evidence that such recovery took place in the North Sea when fishing was restricted by the war, though the increase which was noted is perhaps not certainly outside the range of natural

<sup>11</sup> Osborn, "Origin and Evolution of Life," 1918, p. 153.

<sup>12</sup> Chamberlin, quoted in Lull, "Organic Evolution," New York, 1917, p. 462.

fluctuations. Until the natural fluctuations in fish population are adequately understood, their limits determined, and the causes which give rise to them discovered, a trustworthy verdict as to the effect of fishing is difficult to obtain.

If such problems as these are to be solved the in-

vestigation of the sea must proceed on broadly conceived lines, and a comprehensive knowledge must be built up, not only of the natural history of the fishes, but also of the many and varied conditions which influence their lives. The life of the sea must be studied as a whole.

### The Efficiency of Man and the Factors which influence it.<sup>1</sup>

By Prof. E. P. CATHCART, M.D., D.Sc., F.R.S.

THE subject of my address—the efficiency of the human organism and the factors which influence this efficiency—is, in my opinion, one of the most important problems of the present day. It is a problem which cannot, however, be considered only from its physiological aspect if it is to receive adequate consideration; its implications are much wider, reaching right down to the very basis of our daily lives. As I am no expert in industry or economics, I shall confine my attention so far as possible to the problem from the physiological side, and leave to others the sociological application.

The term "efficiency" has become a mere catchword, banded about by people who have not the faintest idea of what the word connotes. Practically it has come to mean, to the average man in the street, the mythical improvement which is to be anticipated from some change in workshop or office organisation—a bigger and better result at a smaller cost. The word has a very definite meaning in engineering science, and this meaning has been transferred from the inanimate machine to the living organism. In the case of the engine, the problem is relatively simple, as the number of interfering factors is not great, but the solution of the problem in the case of the organism is beset with many difficulties, as the interfering factors are numerous and varied. Two types of efficiency are spoken of in connexion with the animal body. One type is the mechanical efficiency in the engineering sense, *i.e.* the ratio which exists between the heat equivalent of the external muscle work done and the energy output of the subject during the performance of the work in question. This is a problem which has attracted many workers, and there seems to be a general consensus of opinion that the efficiency of man in the performance of external work is about 20 per cent. gross and 25 per cent. net. The other type of efficiency is that which is called industrial or productive efficiency, where the capacity of the individual to perform effective work is dealt with, judging the capacity of the individual by, for example, his output in unit time. So far as the worker himself is concerned, the whole object in industrial efficiency is undoubtedly to get the greatest output with the minimum of effort. The determination of the mechanical efficiency is fairly readily carried out, but it is very difficult to get an accurate gauge of the industrial efficiency. At bottom they are closely related, and both are physiological problems.

The leaders of industry have not been slow to accept and utilise the gains of science in the realm of inanimate

things, but they have been slow to recognise the fact that there is a science of physiology which deals with the man who controls the productive machinery. New inventions may completely revolutionise shop equipment, good machines may be replaced by better, and better by still better, but man remains almost as immutable as the ages. Physiological evolution is infinitely slow, and man has not yet become "an affectionate machine-tickling aphid."

It is but a little more than a hundred years since this country was industrialised, and we are still reaping the aftermath of the terrible conditions which then reigned, when the great centres of industry were swamped with country dwellers who poured into the towns in the race for wealth. Few realise the hopelessly unphysiological conditions which developed in the methods of work, the hours and conditions of work, the housing. The following citation from Robert Owen gives a good idea of the conditions ruling in the early years of last century in one of our staple industries: "In the manufacturing districts it is common for parents to send their children of both sexes at seven or eight years of age, in winter as well as summer, at six o'clock in the morning, sometimes, of course, in the dark, and occasionally amidst frost and snow, to enter the manufactories which are often heated to a high temperature, and contain an atmosphere far from being the most favourable to human life, and in which all those employed in them very frequently continue until twelve o'clock at noon, when an hour is allowed for dinner, after which they return to remain, in a majority of cases, till eight o'clock at night." Six till eight, with a break of one hour; a fourteen hours' day, and fifteen was not unknown. Owen, in the article from which I have quoted, was petitioning Parliament, asking what? That a twelve hours' day be instituted, to include one and a half hours for meals, and that no child should be employed until the age of ten was reached. He pointed out in the course of the article that the results from the manufacturers' point of view would be better with a twelve hours' day (*i.e.* that the industrial efficiency, in modern words, would be improved).

Yet we wonder that the offspring of stock descended from workers under these conditions, which certainly improved as the century advanced, but were far from ideal, gave the high yield of C3 lads recorded in the National Service Report. We might have been prepared for the disclosure, as the pre-war records of countries with conscription showed that the number of rejections for the Army of town and factory workers was far in excess of those for men drawn from country districts. But evidence of the state of the national

<sup>1</sup> From the presidential address delivered to Section I (Physiology) of the British Association at Hull on Sept. 8.

physique is not confined to these war figures. Sir George Newman, in his valuable and interesting Report on Preventive Medicine, has directed attention to the enormous amount of time which is annually lost through sickness. The minimum average amounted to 14,295,724 weeks (or a period upwards of 270,000 years) of sickness per annum, and this figure did not include absence from work due to maternity benefit, sanatorium treatment, or absence for less than four days per patient. This is the evidence of the National Health Insurance.

The design of the organism which has to stand the strain is not at fault. It is an organism which, in the language of the engineer, is abundantly supplied with factors of safety, and has an over-all high factor of safety. The body is not designed merely to perform the minimum amount of work or to stand the minimum strain; there is always a reserve. The perfect co-ordination of the different parts of the organism is required, because the human being is capable of intense muscular exertion for short periods. The intensity of the work is, as a general rule, inversely proportional to the length of time during which it must be carried out.

If, in the human organism, we were concerned merely with the co-ordinated action of a series of effectors, with the capacity of a certain group of muscles to perform a given amount of work, the solution of the problem would be relatively simple. But we are dealing with a living organism, capable not only of doing work, but of repairing the worn-out parts, as and when required. Further, we are dealing with an organism which varies not only in its capacity to perform work, but in its "will to work." We are dealing with a subtle organism which has a whole series of protective mechanisms at its command, an organism which can be fatigued and rendered useless, as a working unit, by an amount of work on a particular day which on another day it can perform with the utmost ease and without apparent fatigue.

The efficiency of a man is not merely dependent on the amount of work which can be performed by his muscles; the circulatory, respiratory, and nervous systems are of equal importance, and all are intimately related. In spite of the many and varied stresses and strains to which the organism is subjected in the course of life, as the result of the many factors of safety, unless the overloading is excessive, too frequent or too long continued, the organism, so long as it remains physiological, is practically unaffected by ordinary hard work.

If we turn now to the consideration of the factors which influence the efficiency, both in the mechanical and the industrial sense, we find that the main controlling factor is undoubtedly the condition known as fatigue. Fatigue is a word just as frequently used as efficiency, and yet it is almost impossible to give an accurate definition of the term. Generally speaking, it is to be regarded as the antithesis of efficiency.

The study of the metabolism has given little or no clue so far to the real nature of fatigue. Benedict and I carried out a certain amount of experimental work on this phase of the question. Our results show that the subject may be on the very verge of absolute collapse, and yet, so far as the metabolic determination goes, there is no very marked evidence of diminished efficiency in a mechanical sense. In an experiment with

M. A. M.; who, in the post-absorptive state, rode on a bicycle ergometer for nearly four and a half hours until on the verge of collapse, doing 208,000 kilogrammetres of external work during the time, the metabolism was determined six times during the riding period with the following result:

TABLE I.

Time.	Oxygen Consumption per min. in c.c.	Rate of Work, revs. per min.	Net Efficiency in per cent.
8.30 A.M. (start)			
9.00 " " "	1967	91.3	23.1
9.45 " " "	1946	91.4	23.3
10.30 " " "	1969	91.7	23.2
11.15 " " "	1948	90.3	23.2
12.00 noon " "	2003	89.0	21.7
12.45 P.M. " "	1899	78.2	21.3

It will be noted, as might be expected, that there is some slowing of the rate at which the work is done, but the diminution in the net efficiency, in spite of the fact that the subject admitted he was completely done at the conclusion of the last determination, is not striking.

Obviously, then, the capacity to carry on is limited by the genesis of fatigue. But it is equally obvious in practice that a man may be engaged in strenuous labour for many hours without acute signs of impending exhaustion. How is this condition attained? There are at least four factors which, to my mind, play predominant rôles in the attainment of maximum efficiency, namely, the rate of the performance of work, the amount of rest offered or taken by the subject, the rhythm with which the work is performed, and the work habits developed by the worker. Although I shall attempt to examine each of these factors separately, it is not to be inferred that they can really be considered as independent phenomena. As a matter of fact, they are all intimately related, and usually merge into one another.

Of these four factors probably most attention has been devoted to the rate or speed at which work is carried out. Benedict and I found, for example, working with a carefully calibrated bicycle ergometer, that there was a very close connexion between the speed at which work was done and the mechanical efficiency. There was a very definite falling off with increased speed, as the following table shows. Unfortunately it was impossible to get our subject to pedal slower than 70 revolutions per minute.

TABLE II.

Revolutions per min.	Gross Efficiency.	Revolutions per min.	Gross Efficiency.
70	20.6	110	17.6
80	20.0	120	16.9
90	19.2	130	16.1
100	18.4	..	..

We found further that if the amount of effective muscular work done was kept constant, that the efficiency fell with an increase of speed. Thus with effective work equivalent to 1.95 calories performed



at the rate of 90 and 124 revolutions per minute respectively, with the lower speed the net efficiency was 22.6 per cent., whereas with the higher speed it fell to 15.7 per cent. Or again, with effective work of 1.58 calories at 71 and 108 revolutions per minute, the efficiency was 24.5 per cent. and 15.6 per cent. respectively; and finally, with effective work of 1.35 calories at speeds of 71, 94, and 105, the efficiencies were 23.1, 20.4, and 17.0 per cent.

A. V. Hill has also recently dealt with this problem in a most interesting piece of work, where the activity was strictly confined to the biceps and the brachialis anticus. He demonstrated very clearly that, in spite of the fact that the slower the contraction the greater was the amount of work done, all the advantage thus gained was rapidly neutralised and dissipated as the result of the slow contraction necessarily causing an increased degradation of energy in the way of physiological changes resulting from the maintenance of contraction. It thus followed that a slow contraction, powerful though it might be, was not necessarily one of high efficiency. Hill found that the maximum efficiency was very rapidly attained, the optimum for the muscles investigated being apparently just less than one second, but the fall which followed, as the duration of the contraction increased, was a comparatively slow one. On account, therefore, of the blunt nature of the curve, the efficiency remained more or less constant over a wide range of speeds.

The load has obviously a direct connexion with the speed at which work is done, but it has also a relation to efficiency. Benedict and I found, for example, that both the gross and net efficiencies within the limits of our experiments increased with the load. The probable explanation of this result is that when light work is carried out, maintenance or physiological requirements which have to be covered form a large proportion of the total energy output, a balance which is steadily altered as the amount of external effective work done increases.

On the other hand, when the loads become excessive there is a definite falling off, both in gross and net efficiencies. Laulanié, who also investigated this question, found that at voluntarily selected speeds, with steadily increasing load, the external work done rose with decreasing speed until the load became excessive. He maintained that there were two optima, (a) an economic optimum at 4 kilo. load with high efficiency and a low oxygen consumption per kilogramme, and (b) a mechanical optimum between 8 and 12 kilo. load when the output in unit time was highest. The following table from Laulanié makes his point clear:

TABLE III.

Resistance in kilos.	1	2	3	4	5	6	8	10	12	15
Speed adopted, metres per sec.	1.49	1.07	0.80	0.61	0.54	0.44	0.37	0.29	0.24	0.13
Work done, kilogrammetres per 5 min.	448	642	726	778	812	853	896	905	906	570
Oxygen intake in c.c. per kgm.	3.5	2.44	2.17	2.14	2.23	2.25	2.43	2.53	3.12	5.31
Efficiency per cent.	14.1	20.4	22.9	23.3	22.3	22.1	20.4	19.7	17.0	9.4

It will be noted that when the load becomes excessive the efficiency rapidly falls away. This means that, although the effort may be continued as strenuously as before, and although the physiological cost of the effort remains at a very high level, the amount of external work done is reduced to a very low figure. The static element in the muscular effort has become dominant,

and static expenditure is parasitic on dynamic work. The more static the work becomes the greater is the fall in the efficiency. Personally I am of the opinion that the severity of muscular work, *qua* the organism as a whole, is a function of the static component of the effort made. Fatigue, *i.e.* inability to carry on, is more readily induced by static work than by either positive or negative work. The following figures, from experiments which I have carried out with Miss Bedale and G. McCallum, show clearly this diminution in efficiency as the static element in the work is increased:

TABLE IV.

Pulls per min.	Kgm. per min.	Cost in grm. cal., per kgm. p. sq. m.	Net Efficiency per cent.
32	40	16	8.0
12	15	17	7.5
6	7.5	29	6.0
4	5.0	31	3.0 r
3	3.75	38	3.0
2	2.5	68	2.0 -
1	1.25	140	1.0

Very closely allied with the rate of working is the rhythm with which the work is performed. Although they are not identical phenomena, they are so closely related that the habit of work may be considered along with rhythm. Every one is well aware that once a rhythm, or the proper co-ordination in the play of a set of muscles in the performance of some definite act, is mastered, not only is the energy expenditure reduced by the exclusion of numerous extraneous muscular activities, but there is an actual enhancement of the ease with which we perform the specified act. It is not a mere question of rate. In a series of experiments which I carried out with Burnett, the subject, working on a specially geared ergometer, was allowed to select his own rate of working, the load being varied from nothing to 4 kilos. At each change of load the subject was directed either to work rapidly or very slowly, and after a period of such work was told to adopt the rate he liked best. As the following table (Table V.)

TABLE V.

Load in kilos.	Rate of Work per min. voluntarily selected.			
	Exp. I.	Exp. II.	Exp. III.	Exp. IV. (Immediately after 1 hour's work at rate of 45 per min.)
0	78	80	83	..
1	80	79	79	71
2	81	80	81	..
3	80	78	83	77
4	82	77	78	..

shows, the rhythm of work was practically identical for all loads. This occurred under all conditions, provided the working spells were not of too long duration. If the work were continued over a long period, the rhythm tended to alter, to increase in speed, and if the subject became really tired, periods of rapid movement alternated with periods of slow movement.

The rhythm adopted, although it may suit the worker, is not of necessity the series of muscle movements which lead to the least expenditure of energy.

Most probably the rhythm selected is only in small part due to the worker's physical configuration; in greater part it is evolved in imitation of some more experienced or older worker. The average workman is not so much concerned with the diminution of the physiological cost in the performance of a given act as in the reduction of conscious effort. It is not, of course, suggested that the methods adopted by workers independently are the perfect methods, and that proper investigation will not discover better and easier methods of performing certain given operations. If newer and more economical methods are to be developed and brought into operation, the only real chance will be to segregate the newer young workers.

There is good evidence, that of Muscio, for example, that both resting and working, in addition to the individual muscle rhythm, there is a definite variation in the course of the day in the capacity to carry out work; that, in other words, a diurnal rhythm exists. There is a certain amount of evidence also in favour of the view that a seasonal rhythm exists. Further, when efficiency is measured in terms of output, it is found that there is a definite rhythm in output during the course of the working day and of the working week. This type of curve is not peculiar to any one industry. The total weekly output curve with the low Monday effect and the sharp fall on Saturday resembles in general shape the daily output curve. The main point about these curves is that they seem to demonstrate the absence of progressive fatigue from overwork, which would have been deduced had there been a sharp rise at the commencement of the week, followed by a steady fall.

The third of the potent factors in the control of fatigue is rest. If work is done, rest is ultimately imperative. Rest not merely relaxes the muscle, allowing a more thorough and complete removal of the waste products and a more abundant supply of oxygen, but it removes the strain of attention. Rest is best obtained, not by simple quiescence, but by change of posture; slow movement of another type to that which produced the fatigue will, unless the organism is tired practically to complete exhaustion, give the most beneficial results.

So far, little attention has been paid to the duration of the rest period in relation to the work done. As a general rule, it may be said that, in the majority of occupations, although the hours of labour are continuous, the actual spells of hard manual work are discontinuous, either due to the fact that certain operations are intermittent in their severity, that supplies of material are not constant, or that, if these more or less natural conditions do not operate, rests at irregular intervals are deliberately taken by the operative. So far as I am aware there is only one type of hard work where a definite rest period is laid down as part of the exercise, namely, in Army route marching.

So much, then, for the ordinary effector factors. There are many other factors directly concerned with the efficient action of the organism, some directly influencing the internal economy of the body, others acting more indirectly on the organism from the environment.

One of these factors is the state of the nutrition. It

may be definitely stated that an insufficient intake of food or the consumption of poor or inadequate food is one of the chief sources of general inefficiency. The capacity of the body to store reserve food material which will meet the daily demands for energy and leave a surplus is another of the vital factors of safety. The much more important problem is unfortunately only too common, the influence of chronic undernutrition, a condition which lowers efficiency, not merely in the actual performance of muscular work, but by inducing an increased susceptibility to disease. This is a question which has never received the attention which its importance demands, largely on account of the immense difficulties of carrying out the investigation in a practical manner. As the direct result of the war, we have the records of at least two sets of observers. Benedict and his co-workers investigated the problem, using a group of twelve men, comparing them with a similar group drawn from the same class. In the experimental group the food intake was reduced, so that there was a loss of 12 per cent. of the body weight. Although the experiment was carried on for more than four months, the diminution in muscle power, so far as laboratory tests were concerned, was not great. The subjective impression, however, of the subjects was that they felt weaker and less capable.

The other recorded experiment is that of the condition in Germany during the war years. A general statement of the effects of the blockade is contained in a long document prepared by the German Government (dated December 1918). Admittedly the document was prepared for a specific purpose; but, after making all allowances, the record of the far-reaching effects of chronic underfeeding is valuable. Apart from the increased death rate, the increased liability to disease, and the slow recovery from the attacks of disease, the document definitely states that the working capacity of the people was reduced by at least one-third. Evidence would also indicate that it is not only the quantity but the quality of the food consumed which plays a part in the fitness of the individual to perform hard muscular work.

Another factor which plays an enormous rôle in the general efficiency is the response of the organism to the multiple psychic imponderabilia which compose such a large part of the average environment. When we are dealing with the efficiency of the human organism, male and female, we are dealing with individuals whose performance is neither uniform throughout the year nor from week to week, nor even from hour to hour. We have to deal with an organism, as I have already mentioned, which is not only under physical control, but is very responsive to psychic influences. Man is, in the main, a psychic chameleon.

In this connexion monotony of work must be considered. Although there may be a close relationship between monotony and fatigue, as generally recognised, they are not identical. The temperament of the operative plays an enormous part in determining whether or no any particular operation is a monotonous one. As Munsterberg has shown, it is extremely difficult, if not impossible, for an outsider to determine what is a monotonous operation.

There are many other factors which play a definite

and important rôle in the maintenance of efficiency, such as lighting, heating, ventilation, the mode of life led by the worker outside his definite hours of labour, his housing, etc. Many of these factors have been partially examined. Thus Leonard Hill has carried out a great deal of valuable work on the influence of the cooling power of the air. Vernon has collected much interesting evidence, which shows that there is a very definite relation between the efficiency, as measured by output, and the temperature of the working place. The output in the hottest weather was about 30 per cent. below that when the weather was coldest. He also observed an apparent connexion between the relative humidity of the air and the efficiency of the worker. The efficiency, as might have been expected, was apparently greatest when the relative humidity was low. Elton has reported on the influence of lighting in silk weaving. He found

that the output was lowest when artificial light was used. He stated that even when electric light of sufficient intensity was used, the output was about 10 per cent. lower than the daylight value. The actual equipment of the factories, the provision of seats of suitable size, height, etc., the design of the machines, and so on, all play their part, as is shown by the many records, particularly from the United States.

In other words, the real over-all industrial efficiency of the worker cannot be causally related to any single factor. It is not the mere capacity of the individual to perform so many kilogram-metres of work in a given time with the smallest expenditure of energy. The quest of efficiency calls for the closest and most intimate co-operation between the scientific investigator, the employer, and the employee, and it can only be satisfactorily attacked when mutual distrust of motives, capacities, and methods is stilled.

### The Total Solar Eclipse of September 21.

By Dr. A. C. D. CROMMELIN.

THE failure of the Christmas Island eclipse expedition is a great astronomical disappointment. Messrs. Jones and Melotte have devoted ten months or more to it, and hoped to secure useful photometric results for connecting the northern and southern stellar magnitude scales in addition to the eclipse work. The climate, however, proved unexpectedly unfavourable, and practically nothing could be done.

On the other hand, the conditions appear to have been ideal right across Australia, and enthusiastic reports have come from Wollal (West Coast), Cordillo Downs (centre), and Goondiwindi and Stanthorpe (Queensland). The Einstein problem was studied at Wollal by the Lick Observatory party under Prof. Campbell, and that from Toronto under Prof. Chant. Mr. Evershed also finally selected this station in preference to the Maldives, and is believed to have undertaken the same investigation, in addition, doubtless, to spectroscopic work. Prof. Dodwell, the Government Astronomer at Adelaide, had the use at Cordillo Downs of a tower telescope lent by the Lick Observatory for the Einstein problem; the New South Wales astronomers were in Queensland and did some spectroscopic work; they intended also to make Einstein investigations, but the telegrams do not allude to these.

It is well to point out that the test of the Einstein theory does not depend wholly on the results of this eclipse. The plates secured in the 1919 eclipse at Principe and Sobral settled definitely that at least the

half-shift was present, while the two cameras with the best definition gave values very close to the Einstein value. Further, the star-field in that eclipse was the best along the whole extent of the ecliptic, the stars in the present eclipse being much fainter. There are, however, two circumstances that should add weight to this eclipse: (1) that some of the observers were pointing directly on the stars, avoiding the use of a cœlostator or other mirror; (2) that the plan was being tried of photographing another star-field *during totality*, thus obtaining an independent scale-value for the plates, which gives a much larger coefficient to the Einstein displacement in the equations of condition.

Probably weeks or months must elapse before the Einstein results are to hand.

The corona is said to have had four long streamers, one extending to three solar diameters, which is more than the average, though by no means a record.

Prof. Chant reports that the shadow bands were photographed. Prof. Kerr Grant, of Adelaide University, made measures at Cordillo by the photo-electric cell of the relative brightness of the sun and the corona. The results, with this very sensitive instrument, should be more trustworthy than previous determinations.

The next two total eclipses (1923, September, and 1925, January) are visible in the United States; 1926, January, in Sumatra, etc., and 1927 in England and Norway.

### Obituary.

PROF. ALEXANDER SMITH.

ALEXANDER SMITH, emeritus professor of chemistry in Columbia University, New York, died in Edinburgh on September 8, aged fifty-seven. Smith was born in Edinburgh, and entered the University there in 1882, where he studied mathematics under Chrystal, natural philosophy under Tait, and chemistry under Crum Brown, graduating as B.Sc. in 1886. During

the following three years he attended the University of Munich, working in Baeyer's laboratory, chiefly under the direction of Claisen, and obtained the degree of Ph.D. in 1889.

After a year spent as assistant in the chemistry department of the University of Edinburgh, Smith was offered the chair of chemistry and mineralogy in Wabash College, Indiana, a post which he held for four years. In 1894 he became assistant professor of

chemistry in the University of Chicago, and rose through intermediate grades to that of professor and director of general and physical chemistry in 1903. Here his extraordinary gifts as organiser and teacher found ample scope. His "Laboratory Outline of General Chemistry" was published in 1899, since when at short intervals new text-books or new editions flowed from his pen. Each book had in view the requirements of students of a definite stage of development, and all were characterised by an orderliness of method, combined with an originality of thought, which have made them popular not only throughout the English-speaking world but also as translations in almost every country where science is studied. An even wider field was offered to him in the principal chair of chemistry in Columbia University in the City of New York, where he became director of the department of chemistry. Here he may be said to have revolutionised the methods of teaching and the organisation for chemical research.

Smith at the outset of his career was an organic chemist, and until 1902 his published papers are all concerned with organic topics, chiefly the chemistry of diketones, the benzoïn reaction, and, generally, the action of potassium cyanide as a condensing agent. After 1902 his work is inorganic and physico-chemical, the physical character of his investigations becoming more and more marked with the lapse of years. An admirable series of papers on the liquid and amorphous modifications of sulphur formed the first-fruits of his cultivation of this new field. Chiefly in conjunction with A. W. C. Menzies, now professor of chemistry at Princeton, Smith published a long series of papers on vapour pressures, many new devices for their exact measurement and for the measurement of boiling-points under standard conditions being described. Among the valuable data obtained may be noted the exact determinations of the vapour pressure of mercury from 25° to 435° C. The vapour pressures of dissociating substances such as ammonium chloride, calomel, and phosphorus pentachloride were also measured and discussed, particularly in connexion with the unexpected values obtained when the substances were perfectly dry. His scientific merit was recognised by his election to membership of the National Academy of Sciences, and to the Presidency of the American Chemical Society. In 1919 the honorary degree of LL.D. was conferred upon him by the University of Edinburgh.

Smith was a most genial personality, a pleasant companion, and a delightfully amusing talker. He was filled to overflowing with energy, which in the end proved his undoing. A breakdown owing to overwork, complicated by a serious operation, forced him after a year's leave to relinquish his chair, and his death at a comparatively early age deprives his science of a great teacher whose name will not soon be forgotten.

J. W.

#### DR. SOPHIE BRYANT.

By the death of Dr. Sophie Bryant in the Alps last month the educational world has lost a great personality. As mathematician, philosopher, Irish patriot, suffragist, and, above all, as a teacher and pioneer in

education, she had gained distinction in so many fields that it is difficult to give any adequate account of her in a few paragraphs.

Mrs. Bryant in her own person gave the lie to the old conception of the unwomanly "bluestocking." Her greatness of intellect was shot through with a warmth of genial humanity and an endearing charm that those who knew her can never forget. She came of a scholarly stock: her father, Dr. Willock, a clergyman of the Church of Ireland in Co. Fermanagh, worked in the cause of education there. After his death the family moved to London, and his brilliant daughter distinguished herself by obtaining, at the age of sixteen, first-class honours in the Senior Cambridge Local Examination, with distinction in mathematics, and an Arnott scholarship at Bedford College. It was only after her marriage and early widowhood that she became acquainted with Miss Buss, and, having joined the staff of the North London Collegiate School in 1875, was one of the first to take advantage of the opening of London University degrees to women. After matriculating in honours in 1879 (with the distinction of being placed second on the list), in two years she had obtained the B.Sc. with honours in mathematics and moral science, and three years later was the first woman to gain the doctor's degree of London University, her subject being mental and moral science. She used to relate an amusing story about this:—one of the two examiners wrote to his colleague, "There's a very good man in;" the other, who knew Mrs. Bryant, replied, "Your man's a woman!"

Ten years later, in 1894, Mrs. Bryant was appointed to sit on the Royal Commission for Secondary Education, of which Lord Bryce was chairman. In 1900 she became a member of the Consultative Committee of the Board of Education, and in the same year took her seat on the Senate of London University. From 1908 to 1914 she was a member of the London Education Committee.

During all this time she was, in a very real sense, a "guide, philosopher, and friend" to her pupils at the North London Collegiate School; the writer of this article is one of many whose debt to her in this respect is beyond all reckoning. When in 1895 Mrs. Bryant succeeded Miss Buss as head-mistress, her mathematical teaching perforce devolved to a large extent on her colleagues, but she remained the guiding moral force in the school, explicitly through her Scripture lessons and weekly addresses, but implicitly in all that she did. She was a pioneer in the revival of Scripture teaching, bringing to bear on religious instruction the same psychological insight and width of outlook by which she and her fellow-reformers brought life into the dry bones of the educational curriculum. Of this work she has left a permanent memorial in her books: "The Teaching of Morality in the Family and the School," "The Teaching of Christ in Life and Conduct," "How to read the Bible in the Twentieth Century," "Moral and Religious Education."

Mrs. Bryant was a devoted Irishwoman, and perhaps no honour pleased her more than the degree of doctor of literature, *honoris causa*, bestowed upon her by Trinity College, Dublin, when first it opened its degrees to women. Her love of Ireland also found expression in her writings: "Celtic Ireland," "The Genius of the

Gael," and the book on the Brehon laws, barely completed before she left England for the last time, which is to be published shortly under the title "Liberty, Order, and Law under Native Irish Rule," dedicated to "the Rebuilders of Ireland United and Free."

Like Plato's philosopher "the spectator of all time and all existence," Mrs. Bryant by her clearness of vision and width of outlook made it impossible to think of anything mean or ungenerous in association with her. She was a great teacher, a great personality, and a splendid friend, a perpetual source of inspiration and joy to those who knew her. Her spirit lives, not only in the school she helped to build (advancing it alike in science and the humanities till it stood first among

a band of sister-schools), but in all those who owe to her a grasp of the ideal, an understanding of the meaning and value of life.

M. II. W.

WE much regret to announce the death on September 21, at the age of fifty-eight years, of Prof. F. T. Trouton, F.R.S., emeritus professor of physics in the University of London.

THE secretary of the Institution of Electrical Engineers informs us of the death of Mr. Louis Heathcote Walter, a member of the Institution staff, who had been editor of *Science Abstracts* since 1903.

### Current Topics and Events.

It was no mean occasion that the members of the Yorkshire Philosophical Society met together on Wednesday, September 20, to celebrate. To have held aloft the lamp of learning for a hundred years, and to have conserved and preserved, amid all the changing scenes and conditions of a century, the ancient ruins of St. Leonard's Hospital, the Roman Wall and the Multangular Tower, the ruins of St. Mary's Abbey, and built up a museum second to none in the provinces in the richness of its collections, is indeed a record of which the society might feel justly proud. Moreover, during this period the society has been instrumental in founding two most powerful and wide-reaching institutions, for the Yorkshire Museum was the birthplace and cradle of the British Association and the younger Museums Association. It was therefore very fitting that the society should celebrate the occasion of its hundredth birthday and receive the congratulations of its honoured patron His Majesty the King, and various universities and learned societies. Mr. W. H. St. Quintin, the president, occupied the chair, and was supported by the vice-presidents and council, the hon. treasurer (Mr. Edwin Gray), the hon. secretary (Mr. C. E. Elmhirst), the keeper of the museums (Dr. Walter E. Collinge), and the Rt. Hon. the Lord Mayor, the City Sheriff, Aldermen, and Council. After briefly tracing the history of the society, the work it has done, and recounting its benefactors, Mr. St. Quintin pointed out that a considerable sum of money will be necessary if the society is to continue its good work for the advancement of science, and he asked that in this, its centenary year, a substantial amount should be forthcoming. Addresses were read or presented from a number of leading scientific societies and other national institutions. His Highness the Maharaj Rana of Jhalawar offered congratulations on behalf of the Indian Empire, and congratulatory messages were received from other distinguished people. At the close of the meeting a highly picturesque procession was formed to the Cathedral, where a special evensong was held, the Lord Bishop of Beverley officiating. The delegates and visitors were later entertained to dinner in the De Grey Rooms, after which a conversation was held in the Yorkshire Museum and the Tempest Anderson Hall.

ACCORDING to the September issue of the *Decimal Educator*, the official organ of the Decimal Association, the metric system has been or is soon to be adopted in Greece, Poland, Haiti, and Japan, while the Russian government is rapidly introducing it into its administrative departments. The British Chamber of Commerce in the Argentine and the Consul for Bolivia again warn British exporters of the futility of quoting in pounds, shillings, and pence for amounts specified in Imperial weights and measures. Mr. W. A. Appleton, secretary of the General Federation of Trade Unions, states that "these weights and measures of ours cheat the home buyer and arouse the suspicion of the foreigner," and asks how many buyers know the difference in weight of a peck of potatoes and a peck of peas. The Lancashire cotton market has ceased to quote cotton in sixty-fourths of a penny and now gives the price in hundredths, but we still appear likely to fulfil the prediction of Augustus de Morgan and "adopt the metric system when every other country has done so." Sir Richard Gregory, president of the association, recommends in an introductory article that the metric system should be made the sole legal system in all departments of State, and the nation thus prepared for its general introduction, which is bound to come in its time, as it is foolish to expect the world to adopt the Imperial as an international system.

A REPORT has been received that the ruins of an ancient city of great extent have been discovered in Colombia by the South American Archaeological Expedition from Chicago. As yet the information is scanty, but Dr. J. A. Mason, the leader of the expedition, states that the ruins are situated in the Province of Magdalena, twenty miles south of Santa Marta: "There must have been a tremendous population here at one time, as the country is covered with house sites. The country is very mountainous, and the houses, which were of wood, were built on terraces made with retaining walls." It is not certain that these terraces may not be those used in terraced cultivation, but Colombia has been little explored, and a detailed report of the excavations must be awaited before the value of the discovery can be estimated.

AFTER having been lost for centuries the remains of the ancient monastery of Nendrum, on Mahee

Island, Strangford Lough, have been brought to light by the agency of the archaeological section of the Belfast Natural History and Philosophical Society. Founded about A.D. 450 it is mentioned in connexion with St. Patrick, and it held for centuries an important position in the Celtic Church. The discovery of the site is due to Bishop Reeves. The most remarkable part of the ruins is a long stone causeway which was probably the monks' walk. Near the north door of the Church a fragment of an important old Norse inscription has been discovered. Words meaning "Prime Abbot" and "Church of Christ" have been interpreted by Prof. Macalister of Dublin. Every effort to preserve the ruins is now being made by the Belfast Society.

On September 16, Sir Humphrey Rolleston, president of the Royal College of Physicians of London, opened the John Elliott Memorial Pathological and Bacteriological Laboratory at the Chester Royal Infirmary, which has been equipped by public subscription in memory of Dr. John Elliott, honorary physician of the infirmary from 1895 to 1921. Dr. Elliott had a well-furnished laboratory of his own, which he used for the elucidation of his cases, and, in addition to his consulting work, was much interested in radiology and in the treatment of venereal disease. The provision of such laboratories in hospitals in recent years has done much to promote the progress of medicine by bringing together the clinician and the worker in pure science; and the pathological laboratory is now recognised as a necessary part of an efficient hospital.

THE Faraday Society and the British Cold Storage and Ice Association will hold a joint meeting at the Institution of Electrical Engineers on Monday, October 16, to discuss the present position of the generation and utilisation of cold. It will be divided into three sessions, at the first of which laboratory methods of liquefaction and methods of measuring low temperatures will be discussed. The opening address will be delivered by Prof. H. Kamerlingh Onnes, and Dr. Crommelin will give a description of the equipment of the cryogenic laboratory at Leyden. The second and third sessions will be devoted to industrial methods of liquefaction and practical applications of low temperatures. A general introduction will be given by Mr. K. S. Murray of the British Oxygen Company (Limited). M. Claude will deal with the industrial manufacture of hydrogen by the partial liquefaction of water gas, and Mr. E. A. Griffiths with the subject as it touches aeronautical work. Invitations have been extended to members of the London Section of the Society of Chemical Industry and to the Physical Society of London. Others desirous of attending should communicate with the Secretary of the Faraday Society, 10 Essex Street, London, W.C.2.

A PROVISIONAL programme of lectures on meteorology in connexion with the Imperial College of Science and Technology, South Kensington, for the ensuing session is given in the *Meteorological Magazine* for September. There are twenty-one lectures by

Capt. D. Brunt on advanced meteorology, dynamical and physical, on Mondays at 3.30 P.M. during the winter and spring terms, beginning on Monday, October 9; seven lectures by Sir Napier Shaw on meteorological conditions of the air-routes of the world, at 3 P.M. on Fridays, commencing on October 13, and continued each week until November 24; three lectures by Mr. R. A. Watson-Watt on wireless telegraphy and weather, at 3 P.M. on Fridays in each of the first three weeks of December; ten lectures on forecasting weather by Sir Napier Shaw on Fridays, at 3 P.M., during the spring term, beginning on Friday, January 19. Discussions on the incidents of the weather charts of the previous week are arranged for on Saturdays at 10 A.M. throughout the year during term-time, beginning on Saturday, October 14.

WE learn from the September number of the *Museums Journal* that Dr. W. Rushton Parker has offered to set aside 100*l.* a year for several years to induce any men excavating in any part of the United Kingdom to look out for fossil remains of any kind, to extract them as completely as possible, and to preserve them until some expert can value them, with the view of presenting them to the National Museums. This is an offer that should be made known to the scientific societies as well as to the museums in various parts of the country.

DR. R. C. FARMER has been invited to take up the position of deputy director of explosives research at the War Office Research Department, and will commence duty in October. Dr. Farmer was formerly chemical adviser to the Explosives Department under Lord Moulton, and was a member of the nitrogen products committee and the chemical committee of the Munitions Inventions Department. Since the armistice he has been a director of Messrs. W. J. Bush and Company, Ltd., chemical manufacturers, of Hackney, London, which position he is now resigning.

A COMMITTEE has been appointed by the Secretary for Mines to undertake research, under the general direction of the Safety in Mines Research Board, into the causes of, and the means of preventing, the ignition of firedamp and coal dust by the firing of permitted explosives. The Committee has been constituted as follows: Sir F. L. Nathan, Mr. W. Rintoul, Dr. G. Rotter, Mr. H. Walker, and Prof. R. V. Wheeler. A grant has been made by the Miners' Welfare Committee out of the Miners' Welfare Fund to meet the cost of initiating the research.

ON account of continued poor health, Dr. George Ellery Hale, director of the Mount Wilson Observatory, has resigned from the Committee on Intellectual Co-operation of the League of Nations. Dr. Robert A. Millikan, director of the Norman Bridge Physical Laboratory of the California Institute of Technology, Pasadena, has been appointed by the council of the league to succeed Dr. Hale.

THE Faraday Medal of the Institution of Electrical Engineers, the first award of which was made by the council in the early part of the year to Mr. Oliver

Heaviseide, was personally presented to him by Mr. J. S. Highfield, president of the institution, at Torquay, on September 9.

THE Secretary for Scotland has appointed Dr. James Ritchie to be an additional member of the committee appointed to advise him on matters connected with the administration of the Wild Birds Protection Acts.

SIR LAWRENCE WEAVER will shortly relinquish the post of second secretary and director-general of land settlement at the Ministry of Agriculture in order to take up the appointment of director of the Art section and of the Agriculture section of the British Empire Exhibition.

THE Model Abattoir Society, the objects of which are the improvement of methods and conditions in slaughter-houses, has organised an annual Benjamin Ward Richardson lecture in memory of its founder. The memorial lecture, on the sanitarian and humanitarian aspects of Sir Benjamin Ward Richardson's work, will be delivered by Sir William Collins on October 12. Admission is free, and invitations may be obtained from the Rev. George Martin, St. John's Vicarage, Kilburn.

MR. W. K. FORD writes to inform us that an unusually large specimen of the common viper, *Viper berus*, was caught recently in Epping Forest. The snake, which was a female, is stated to be 29.5 in. in length, the tail measuring 3.12 in. The largest specimen in the British Museum is only a little more than 27 in. in length, though on account of the difficulty of measuring a snake's skin without stretching it—it can be stretched to one and a half times its real length—larger specimens have been recorded. Mr. Ford's specimen appears to be unusually large, but the skin should be submitted for examination to the Zoological Society, Regent's Park, or similar authority, before it can be accepted as a record.

A "WIRELESS WEATHER MANUAL" has been published by the Meteorological Office of the Air Ministry. It is a guide to the reception and interpretation of weather reports and forecasts distributed by wireless telegraphy in Great Britain. A table is given showing the information issued by wireless, revised to June 1, and the instructions are clear and concise for persons who possess wireless receiving sets. It is not only possible to pick up the messages distributed, to aid which the codes used are interpreted, but a "general inference" is given by the Meteorological Office in plain language twice daily, which with a very little intuition can be understood by those little versed in meteorology. A study of the manual will aid in the general understanding of the subject and will render the charting of the information received quite simple. A short list of elementary text-books is given, a study of which will simplify the interpretation of the charts. A weather chart is given daily in many of the newspapers, but the wireless information gives the details much earlier, for it is possible to draw a weather map within about an hour of the observations being made. In the introduction to the manual, it is stated that those wishing to know can find out "what the weather will be in the next twenty-four hours (sometimes longer)."

THE Automatic and Electric Furnaces, Ltd., informs us that the increasing demand for Wild-Barfield electric hardening furnaces has made necessary the removal of the firm to larger works and offices. The address now is: Automatic and Electric Furnaces, Ltd., Elecfurn Works, 173-175 Farringdon Road, London, E.C.1. Demonstration rooms with furnaces in operation will be provided, and suitable arrangements made for hardening large and small parts for firms which desire to compare both the results and costs with those obtained by gas or solid fuel furnaces. Laboratory and industrial electric muffles will also be available for trial purposes.

### Our Astronomical Column.

THE ORBIT OF SIRIUS.—This orbit is of peculiar interest from the conspicuous brightness of the primary, from the irregularity in the proper motion having led to a prediction of its duplicity, and from the subsequent verification by the discovery of the companion in 1862. It now presents one of the not very numerous cases in which a complete revolution has been observed. The various determinations of the elements that have recently been published give an index of the degree of accuracy that is attainable. A new determination by Mr. C. P. Howard is given in *Pop. Ast.* (Aug.-Sept. 1922), and that by Mr. R. Jonckheere (*Mon. Not. R.A.S.*, June 1918) is printed for comparison. Both were made by graphical methods, using every refinement possible:

	Howard.	Jonckheere.
Periastron passage . . . .	1894.25	1894.10
Period in years . . . . .	50.17	50.00
Eccentricity . . . . .	0.5938	0.60
Semi-axis major . . . . .	7 <sup>h</sup> .482	7 <sup>h</sup> .55
Inclination . . . . .	42°.01	43.4
Node . . . . .	44°.56	42°.7
Arc from node to periastron	148°.38	145°.6

AN INTERESTING ALGOL VARIABLE.—Mr. A. H. Joy gives a discussion of the Algol Variable, RS Canum Venaticum, in *Publ. Ast. Soc. Pacific*, August 1922. It is possible to study the spectra of both components, since the faint star is the larger, and totally eclipses the brighter star at principal minimum, when the magnitude is 9.0. The two stars are of equal mass, each 1.3 times the sun; they differ greatly, however, in spectral type, the brighter being F3, the fainter K0. This wide difference is difficult to explain in view of their equal mass. The period is 4.8 days, and the radius of the orbit of each component 5,700,000 miles. The absolute magnitude of the brighter star, deduced from its spectrum, is 2.8, giving a parallax of 0.008. Three spectrograms have been obtained of the faint star by Mr. Adams; the star is too faint to give satisfactory spectrograms, but it is stated that, taken by themselves, they would indicate a dwarf star. However, from its large size, indicated by the duration of totality being two or three hours, and consequent low density, there can be little doubt that it is really a giant; its absolute magnitude, about 4.2, is very low for a K giant. Altogether the star is rather a puzzling one, and merits careful study.

## Research Items.

**THE OLDEST-DATED SEAL CYLINDERS.**—M. Leon Legrain, in the March issue of the *Museum Journal*, claims for the University Museum, Philadelphia, the possession of the oldest-dated cylinder seal, brought from Baghdad in 1890, which belonged to Basha-Enzu, probably the first king of the 14th Kish dynasty, about 2900 B.C. It therefore antedates the famous buffalo seal of Sargani of Akkad, and pushes back toward the third millennium B.C. a standard of art formerly known as the Gudea style. The engraving is of special interest from the point of view of Babylonian ritual. The museum also prides itself on possessing the oldest Cassite royal seal cylinder so far known, bearing the earliest contemporary record of the war god Shugamuna. It is inscribed with the name of the son of King Karaindash, and may be dated about 1540 B.C.

**HONEY THAT DROVE MEN MAD.**—In the September issue of *Discovery*, Prof. W. R. Halliday, with the help of his colleague, Prof. McLean Thompson, has cleared up a difficulty unsolved by editors of Xenophon's "Anabasis." The historian describes how the retreating Greeks, when they arrived near Trebizond, ate some honey, with effects ranging from intoxication to insensibility. Some authorities have denied that poisonous honey was found in Pontus, but the writers now point out that there is no evidence to show that the breed of bees in Pontus, or the general climatic condition, was responsible for this poisonous honey. When honey is produced in excess, and the floral parts fail to develop, there results an accumulation of by-products in which toxins abound. When the competition for nectar pollen is intense many insects develop a biting habit, piercing the tissues of plants in search of short-cuts to food supply, and this habit results in the formation of poisoned honey. The observation of Pliny that honey was poisonous on some seasons and not in others is thus proved to be accurate, and can be explained on scientific grounds.

**THE ROCKS OF MOUNT EVEREST.**—In the *Geographical Journal* for September, Dr. A. M. Heron has a note on a small collection of rock specimens made at heights between 23,000 ft. and 27,000 ft. by the climbers on the recent expedition. These specimens show Mount Everest to be a pile of altered sedimentary rocks—shales and limestones—converted into banded hornfels, finely foliated calc-silicate schists, and crystalline limestones. They confirm the views reached by Dr. Heron last year by examination of moraine material from the northern spurs, and by inspection of the mountain by telescope from the Rongbuk valley. From 21,000 ft. to 27,000 ft., Mount Everest appears to be built of these dark hornfels and schists, with occasional bands of white limestone and veins of quartz and muscovite granite. From 27,000 to 27,500 ft. extends an almost horizontal belt of schorl muscovite granite, above which are black schists. Dr. Heron thinks that the age of the rocks may perhaps be assumed, for the present, to be Jurassic or Trias.

**WIND-SPEED FROM SEA AND LAND.**—The Meteorological Office has issued, as Professional Notes No. 28, a comparison of the anemometer records for Shoeburyness and the Maplin lighthouse, by Messrs. N. K. Johnson and S. N. Sen. The wind-speed in each case is recorded by a Dines pressure tube anemometer. For wind direction Shoeburyness has been used throughout, the Maplin direction recorder being out of order. The wind-speed observations are only available for about ten months in 1919, no observations

being to hand from Maplin for the comparison from June 12 to September 1. Maplin lighthouse is five miles from the coast, and is situated twelve miles east-north-east of Shoeburyness. The head of the anemometer at Shoeburyness is carried above the top of a steel girder tower to a height of sixty feet above the surrounding buildings and ninety feet above ground, but there is an avenue of trees about seventy feet high running parallel to the coast at a distance of 150 yards on the landward side of the anemometer. At Maplin the head of the anemometer is about five feet above the apex of the roof of the lighthouse, on the western side, being fifty feet above sea-level. Shoeburyness is said to have a slight predominance of light winds, and at Maplin lighthouse strong winds are decidedly more frequent; the latter is explained by the suggestion that the increased friction over land as compared with the sea causes the air to pile up over the land. This difference of pressure, it is said, must tend to reduce the speed of the surface wind as it approaches the shore-line. There is good evidence of the land and sea-breeze. The height of the head of the anemometer at Maplin seems scarcely sufficient to insure that it is clear from an upward rush of air caused by the obstruction of the lighthouse.

**METALLURGICAL RESEARCH.**—Volume 16 of the Collected Researches of the National Physical Laboratory has recently been published. It is predominantly of a metallurgical character, although certain papers dealing with engineering subjects are contained therein. The twenty-one papers which it contains are all reprints of papers published by members of the staff in various scientific and technological journals during the years 1919 and 1920. Fourteen of the papers are definitely metallurgical, and a considerable number of these relate to aluminium and its alloys, which have been intensively studied during the last few years, under the general superintendence of Dr. Rosenhain, the head of the department. These investigations are of a very valuable nature, and have contributed in no small degree to the continually extending use of aluminium alloys, not only in aviation, but also in general engineering. Of the papers dealing with iron, attention may be directed to that published by Dr. and Mrs. Hanson on the constitution of nickel iron alloys. The investigations of these authors on this series of alloys have finally enabled the general nature of the equilibrium diagram to be settled once and for all, although they are careful to point out that no very high degree of accuracy can well be claimed. It is interesting to notice that the general result of their researches is to establish firmly the late M. Osmond's hypothesis of the constitution of these alloys, particularly in the range from 0.30 per cent. of nickel. The importance of keeping down the impurities to a minimum is clearly seen in this work, otherwise a true equilibrium is not established. Attention may also be directed to the paper by Dr. Haughton on the study of thermal E.M.F. as an aid in the investigation of the constitution of alloy systems and on the measurement of the electrical conductivity of metals and alloys at high temperatures. The volume contains a paper of the first importance by Dr. Stanton, D. Marshall, and C. N. Bryant on the conditions at the boundary of a fluid in turbulent motion, and two papers by Mr. Baker, the superintendent of the William Froude National Tank. The high character of the series is well maintained in the present volume.



The Inheritance of Size.<sup>1</sup>

THE study of size-inheritance is beset with difficulties which do not attend the study of qualitative differences involving colour and form. Students of genetics have stated size-inheritance in various plants and animals in terms of multiple size factors segregating independently in the Mendelian fashion; but the universal presence of fluctuations which obscure the quantitative effects of separate factors, as well as other difficulties, have prevented the study of size factors being in the same satisfactory condition as that of the factors which control sharply marked qualitative characters.

Stature in man has been investigated from the time of Quetelet and Galton to the recent paper of Davenport,<sup>2</sup> but investigators are not yet agreed even concerning the nature of the Mendelian units, if such they be, which affect and control this feature of bodily measurement. Are there only general growth factors, or are there also separate factors influencing the length of individual segments of the body, such as the legs, trunk, and neck? Davenport concludes that both types of factors are present, and that some races and families have different relative lengths of these segments because of the independent inheritance of such local factors controlling the length of individual bones or segments. Moreover, Davenport believes that crossing between races leads to various bodily disharmonies, such as large teeth in small jaws or a small heart in a large body.

Castle, in a recent study of size-inheritance in rabbits,<sup>3</sup> criticises Davenport's view of local size factors as essentially preformationist, and shows with considerable success that, so far as the rabbits of his breeding experiments are concerned, general inherited growth factors appear to control the size reached by all parts. In crosses between the large Flemish rabbit and small varieties such as the Polish and Himalayan, Castle concludes, as Punnett and Bailey<sup>4</sup> had concluded from earlier experiments on weight in rabbits, that several size factors are involved, as indicated by the greater range of variation in  $F_2$  and later generations than in  $F_1$ . This substantiates other results of these authors<sup>5</sup> with poultry. They crossed Gold-pencilled Hamburgs and Silver Seabright Bantams and obtained in  $F_2$  and  $F_3$  both larger and smaller birds than the original parental types. That several independent factors are concerned in the determination of size or weight in birds and mammals seems then well established.

But another difficulty comes in to obscure such quantitative results, and that is the fact of hybrid vigour or heterosis, which occurs largely or entirely in the  $F_1$  generation, producing a general increase in the size of the  $F_1$  offspring. For example, in the rabbit crosses, the  $F_1$  is nearer the size of the larger parent owing to this effect, but the effect disappears in the  $F_2$  and later generations. This of course shifts the curve of size temporarily towards the right.

Castle made a careful study of the growth-curves of his rabbits, weighing them at intervals throughout their development to maturity, but he appears not to have studied the variation of his races before

crossing. He concludes that the adult Flemish rabbit is larger because it is larger at birth and grows more rapidly and for a longer period than the small Polish rabbit. This is contrary to the views of Punnett and Bailey that age of maturity is not necessarily closely correlated with size. Castle applies his results to man, and reasons that natives of the south of Italy are short of stature and short-limbed because they cease to grow at a relatively early age, while Swedes and Scotch are tall and long-limbed because they mature later.

In the hybrid rabbits, series of measurements were made of weight, ear-length, skull dimensions, and certain leg bones. From these data the correlation-coefficients between the various measurements were determined and were found to be uniformly high. Thus the correlation between ear-length and weight in  $F_1$  and  $F_2$  rabbits was 0.836, and between lengths of femur and skull 0.871. This furnishes strong support for the conclusion that the size of all parts is determined by general growth factors affecting the whole body, and not by independently segregating factors affecting the size of particular organs. Davenport points out that certain races of man have long legs and relatively short trunks, while others have short legs and longer trunks, but Castle holds that the former races are absolutely taller, and regards them as a later growth stage than the short races. Whether this explanation will apply to all races of man remains to be seen. The most urgent requirement at the present time is a mass of accurate anthropometric measurements of all parts of the body in various races.

Many genetic factors are known to affect chiefly one organ of the body, such as the eye or the wing in flies, and since that is the case there seems no *a priori* reason why some size factors should not also affect chiefly certain organs. To demonstrate such an effect, however, a considerable mass of biometric data is required. So far as plants are concerned, the results of Gates<sup>6</sup> show that size factors in hybrids are in some cases local in their effects. In crossing species of *Oenothera* having large and small flowers respectively, he obtained in  $F_2$  and later generations frequently a wide range of flower-size on the same plant, and in many cases even the four petals of the same flower differed widely in length. Thus it is clear that local size factors occur in plants. Whether they also occur in animals and man remains to be determined.

That an increase in the range of variation of the  $F_2$  as compared with the  $F_1$  is not in itself sufficient to prove the presence of several inherited size-factors, is indicated by a recent paper of Sumner and Huestis.<sup>7</sup> In connexion with extensive breeding investigations of the California deer-mouse, *Peromyscus maniculatus*, they have compared the length or weight of corresponding right and left bones such as the mandible and femur. In this way they obtained sinistro-dextral ratios for these bones and showed statistically that there is no inheritance of such a ratio from one generation to the next, e.g. if the parents had a slightly longer left femur there is no tendency for the same condition to be repeated in the offspring. Nevertheless, they found that in crosses between different sub-species these ratios showed greater variability in  $F_2$  than in  $F_1$ . This fact will need to be taken into account in future studies of size-variation.

<sup>6</sup> Gates, R. R., 1917, "Vegetative Segregation in a Hybrid Race," *Journ. Genetics*, 6, pp. 237-253.

<sup>7</sup> Sumner, F. B., and Huestis, R. R., 1921, "Bilateral Symmetry in its Relation to certain Problems of Genetics," *Genetics*, 6, pp. 445-485.

<sup>1</sup> "Genetic Studies of Rabbits and Rats." By W. E. Castle. (Publication No. 320.) Pp. 55. (Washington: Carnegie Institution, 1922.) 1 dollar.

<sup>2</sup> Davenport, C. B., 1917, "Inheritance of Stature," *Genetics*, 2, pp. 313-389.

<sup>3</sup> Castle, W. E., 1922, "Genetic Studies of Rabbits," etc.

<sup>4</sup> Punnett, R. C., and Bailey, P. G., 1918, "Genetic Studies in Rabbits: I. On the Inheritance of Weight," *Journ. Genetics*, 8, 1-25.

<sup>5</sup> Punnett, R. C., and Bailey, P. G., 1914, "On Inheritance of Weight in Poultry," *Journ. Genetics*, 4, pp. 23-39.

## An Optical Sonometer.

ONE form of an optical sonometer recently made by Messrs. Adam Hilger, Ltd. (of 75A Camden Road, N.W.1), is shown diagrammatically in Fig. 1. The

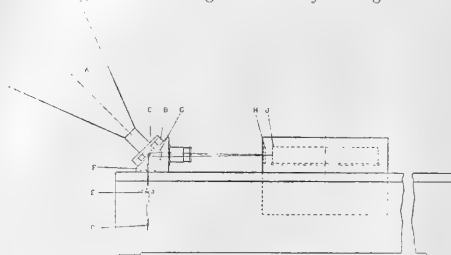

FIG. 1.

apparatus is designed to record the pressure variation caused by sound waves. It consists of a diaphragm box B, to which is attached a horn for receiving sound waves. In box B is a diaphragm with a platinised, silvered, or gilt inner face; this is the actual receiver. Recording the vibrations produced in the disc is accomplished by means of a beam of light directed from the source D (a Pointolite Lamp of 30 or 100 candle-power) by a condenser E through the slit F and brought to a focus on the diaphragm C. Thence by means of lenses G and H an image of the slit is formed on the photographic paper

or film on the drum J. The lens H being cylindrical with its axis parallel to the drum, the beam of light is brought to an intense point image on the drum, and as the latter rotates a record of the deflection of the diaphragm is obtained. The spot of light can be focussed on the drum at any distance from 4 to 20 inches according to the amplitude of vibration under investigation and the degree of magnification consequently required.

Some of the models constructed are fitted with a camera into which the film is loaded through a small aperture at the back, while an arrangement for visual observation of the sound wave is also included. The revolving drum, on which the record of the vibrations is made, is enclosed in a specially designed camera with an automatic shutter; by this means any fraction of the drum, from one-sixth to one complete revolution, can be exposed according to the type of record which it is desired to make.

Records of various sounds have been made with the apparatus, e.g. for whistling at a frequency of about 1300 per second, singing at about 200 per second, and



FIG. 2.

of the sound produced by a leather-covered mallet on wood. This last is shown in Fig. 2, the frequency being about 250 per second.

## The Rowett Research Institute, Aberdeen.

THE Rowett Institute, which was formally opened by Her Majesty the Queen on September 12, had its origin in the scheme of research in agriculture adopted by the Development Commission in 1911. Under that scheme provision was made for the establishment of one or more Institutes to carry out research in each of the branches of agricultural science. It was decided to establish two Institutes for the study of Animal Nutrition, one at Cambridge and one in Scotland. In 1913 a Joint Committee representing the University of Aberdeen and the North of Scotland College of Agriculture was constituted to act as a governing body for the Scottish Institute. Preliminary work was begun in 1914, but was stopped by the war. In 1920 the scheme for the development of the Institute was approved by the Board of Agriculture for Scotland and the Development Commission, and the erection of the buildings began early in 1921. The buildings are now practically completed, except for the fitting up of one or two of the laboratories.

In determining the nature of the Institute to be established it was recognised that the basis of practical experimental work is the researches of the purely scientific worker. Provision was therefore made for work in those branches of science that constitute animal nutrition. The Institute was planned to consist of the following departments: physiology, biochemistry, bacteriology, and pathology, which are housed in the one main building, and animal husbandry,

which consists of an experimental stock farm with buildings adapted for conducting feeding experiments. To facilitate the collaboration of those engaged in laboratory researches and those carrying out feeding experiments, the main building containing the laboratories has been erected on the experimental farm. This enables the workers to be in daily contact with each other, and to be conversant with the different aspects of the problem or group of problems on which the Institute is engaged.

The experimental farm is situated on the outskirts of Aberdeen, within easy access of tramway and train. The building containing the laboratories is built of granite and is 156 feet long by 45 feet deep in the central block and 39 feet deep in the wings. It consists of two floors and a basement. The biochemical department, the calorimetry room, the aseptic room, and certain other rooms occupy the ground floor. The physiology and the bacteriology and pathology departments are on the first floor. In the west wing of this floor is the administrative department, rooms for filing records and statistics, and the library. About 30 yards west of this building are the experimental farm buildings which have a floor area of about 1500 square yards. The part nearest to the building containing the laboratories is occupied by two rooms, where animals under metabolic experiment can be kept in cages. The rest of the building consists of food stores, food preparation rooms, and stalls and pens for the

accommodation of farm animals under feeding experiments.

The capital outlay, which was estimated in 1920 at 40,000*l.* to 50,000*l.*, will amount to about 46,000*l.* Of this sum the Treasury, on the recommendation of the Development Commission, provided 20,000*l.* Mr. John Quiller Rowett, LL.D., generously contributed 10,000*l.*, and in addition supplied sufficient funds to purchase the experimental farm. Various smaller sums have been received from other contributors; but the whole of the necessary funds have not yet been raised.

The Queen, at the opening ceremony, visited all the departments and talked with the senior workers, asking questions that showed a deep interest in the research work in progress. She was especially interested in the work on indirect calorimetry, and asked to be shown all the apparatus and to have

the method explained. In the experimental farm she was chiefly attracted by the dairy cows. These are Ayrshires, a breed kept at the Balmoral Estate. She asked questions about the breed and also about milk production in general, which showed an interest in and an appreciation of the importance of the dairy industry.

After the visit to the different departments the Queen proceeded to the library, where there was a company of about 120, including the Duchess of Atholl, the Duke of Richmond and Gordon, the Marquis and Marchioness of Aberdeen, the Marquis and Marchioness of Huntly, and representatives of public bodies. Here she was presented with a gold key by Dr. Rowett, and formally declared the Institute open. She signed the visitors' book, and before leaving planted a tree in the grounds of the Institute to commemorate the visit.

### The Sun's Activity, 1890-1920.

THE sun, as is well known, is a variable star having a period of approximately eleven years, but, unlike other stars, its variability can be determined from several different visible phenomena and not solely from the total integrated light emitted. As classed among stars, it is not considered, however, as a regular variable, because the approximate period of eleven years is itself made variable through other minor periods of various lengths.

Though the sun has a dominating action on many terrestrial phenomena, authorities differ as to the exact relation between the pulsations of the two bodies. It is important, therefore, always to keep in mind, so far as possible, the actual state of solar activity at the moment, *i.e.* whether the sun is in a quiescent state through lack of spots and prominences, or whether it is in a very turbulent condition caused by their abundance.

The data for determining the state of the activity of the sun are published separately year by year in various volumes from different sources, and are only brought together, probably with some difficulty, by research workers who wish to use them for particular inquiries.

Dr. W. J. S. Lockyer has recently coordinated the solar data regarding the sunspotted area, the latitudes of the activity zones of sunspots and prominences, together with the variations in the form of the corona for the period 1920 to *as near the present as possible*. The accompanying diagram (Fig. 1) illustrates the solar changes in graphic form. The following paragraphs deal briefly with each set of curves individually, including the sources of the data:

**MEAN DAILY AREAS OF SUNSPOTS.**—Each of the points in the curve represents the mean of the daily areas of sunspots corrected for foreshortening for each year. The values are published by the Astronomer Royal yearly in the Monthly Notices of the Royal Astronomical Society, the last value published being that for 1918 (vol. 82, p. 485). The three later years marked with crosses are only provisional values.

It will be seen that the maximum spot activity occurred in the years 1893, 1905, and 1917, while the years of minimum were 1901 and 1913. The next minimum will probably fall in 1924 or 1925.

**LATITUDES OF SUNSPOTS.**—Under this heading there are two sets of curves—one for the northern and the other for the southern hemisphere of the sun. Each point represents the mean heliographic latitude of all spots for each hemisphere throughout the whole

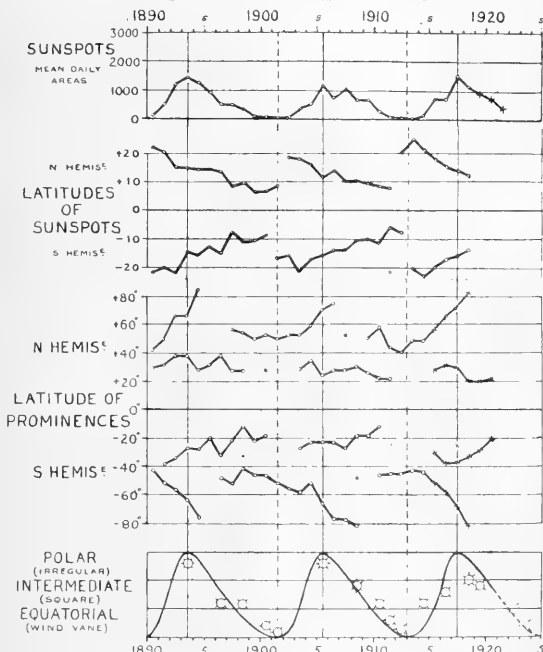

FIG. 1.

year. The data are taken from the same sources as mentioned above. It will be noticed that a new sunspot cycle is always heralded by outbursts of spots in zones of high latitudes (about 22°), while the zone of spots nearer the equator is dying out.

**LATITUDES OF PROMINENCES.**—Here also there are two sets of curves, one for each hemisphere; where in the case of the spots there was only one zone for

each hemisphere, for prominences there are two zones. Each point in the curves represents the mean latitude of each zone throughout the year. It will be noticed that in each hemisphere the zone in lower latitudes gradually approaches the equator, dying out just before or at sunspot minimum, while the zone further away from the equator increases its latitude rapidly and dies out at or a little after sunspot maximum. The data up to 1914 are published in the Memoirs of the Kodaikanal Observatory (vol. 1, part ii.) by Mr. John Evershed, and the remainder have been extracted from that Observatory's Bulletins published half-yearly, from which the mean yearly latitudes of the zones have been provisionally determined by Dr. Lockyer.

**THE FORMS OF THE CORONA.**—The last curve shows the condition of activity of the sun as indicated by the form which the corona takes when seen at total eclipses.

When the corona (polar form) exhibits streamers all around the solar disc, *i.e.* in all solar latitudes, this indicates a very turbulent state of the solar atmosphere and a time therefore of maximum activity. At this time the prominences reach their highest latitudes. When the streamers are confined to the equatorial regions and the poles are quite clear and void of streamers, the corona takes an "equatorial" or "wind-vane" form, and the solar activity is at a minimum. Intermediate stages are indicated by the corona taking an "intermediate" or "square" shape. The various forms of the corona are indicated clearly in the curve by three different symbols. The curve also shows the forms expected in the two approaching eclipses, namely, of this and of next year. The form for the present year will be of the "intermediate" type, while that for 1923 should be typical of the "equatorial" type. The data for the various forms of the corona have to be obtained from the individual reports of eclipse expeditions, but those to which reference has here been made have been collected by Dr. Lockyer and published in the Monthly Notices of the Royal Astronomical Society (vol. 82, p. 326).

All the solar phenomena described above thus indicate clearly that the activity of the sun is decidedly on the wane, and that the epoch of minimum disturbance in the solar atmosphere is approaching and will be reached in the year 1924 or 1925.

### University and Educational Intelligence.

**BRISTOL.**—The degree of Ph.D. has been awarded to Mr. Joseph Lineham for his dissertation on "The Concept of Activity."

**LONDON.**—The list of courses of University Extension Lectures for the session 1922-23 has recently been issued, containing particulars of some 90 courses and lectures which will be given in the University and locally. Of this number, 14 only are on scientific topics. Dr. W. B. Brierley is giving a course of 24 lectures at Gresham College on inter-racial problems of man, and a similar course at Morley College on the principles of evolutionary biology; F. Womack is giving 2 lectures on wireless telephony at Hatch End and at Hounslow, and 5 lectures on pioneers of science at Wood Green; and F. J. Chittenden, 3 lectures on horticulture at Hatch End. The remaining science lectures are related to psychology: Miss V. H. Hazlitt, 10 lectures on the psychology of character and conduct, at Croydon; Mr. Cyril Burt, 5 lectures on psycho-analysis, at Twickenham; S. E. Hooper, 24 lectures on psychology, at Wimbledon and also at Wood Green; and E. O. Lewis, 24 lectures on psychology, at the

Working Men's College, Crowndale Road, N.W. There are also four psychology courses, at Croydon, at the Mary Ward Settlement at Tavistock Place, W.C., at Wandsworth, and at Wood Green, for which lecturers' names are not yet given. Further particulars of the lectures can be obtained from the local secretaries whose addresses are given in the lecture list, application for which should be made to the Registrar, University Extension Board, University of London, South Kensington, S.W.7.

THE *Chemiker Zeitung* of August 29 reports that Dr. H. Lecher, of the University of Munich, has been appointed professor of organic chemistry at the University of Freiburg.

A SPECIAL committee of the World's Student Christian Federation has been appointed to co-operate with the Universities' Library for Central Europe in its work of securing British books, journals, and scientific papers for the universities of Central Europe. Donations of books, periodicals, and money should be forwarded to Mr. B. M. Headicar, Universities' Library and Student Relief for Europe, London School of Economics, Houghton Street, W.C.2.

ON several occasions recently the *Chemiker Zeitung* has reported the gifts of large sums granted by industrial concerns to universities and to associations of students, for the assistance of these bodies in teaching scientific subjects, particularly chemistry. Although the amounts, which run into millions of marks in individual grants, may seem modest when translated into English currency, they represent important contributions in Germany, and the attention of British manufacturers might well be invited to the matter. It is evident that Germany realises, as she did in former years after defeat, that the hope of the future lies in education, and one cannot help feeling that the victors in the recent war would do well to consider whether their future also does not lie in the same direction, and do a little more of a practical character in the furthering of the work of our educational institutions. The reduced grants made to the universities will be reflected in reduced facilities, and if the industries which have reaped so much benefit from research in pure science made in the universities, often associated with individual hardship on the part of the students, were to make some return, it would be repaid to them a hundred-fold.

THE draft Regulations for Secondary Schools recently issued by the Board of Education remedy the anomalous position which hitherto geography has occupied in advanced courses. As a school subject, geography has steadily gained ground, and in 1921 was offered by no less than 78 per cent. of the candidates taking the School Leaving Examination. Furthermore, Sir Richard Gregory, in his presidential address to the Education Section of the British Association this year at Hull, pointed out the still greater part this subject could, and should, play in economy of time-table and efficiency of teaching. At the other end of the scale, the Universities have steadily increased the facilities for graduation in geography. There remained, however, the hiatus of the advanced courses which cut off, in large measure, the supply of students of geography. The 1922 Regulations provide for a new group of studies, E, which is defined as "Geography, combined with two other subjects approved by the Board, of which one must be History or a Science." The way is now clear for a complete revision of the syllabuses in geography for the Higher School Certificate and for the provision of university scholarships in this subject.

## Calendar of Industrial Pioneers.

**October 1, 1838.** Charles Tennant died.—The founder in 1797 of famous chemical works at St. Rollox, Glasgow, Tennant while manager of a bleaching field near Paisley discovered a method of controlling chlorine gas by the admixture of lime. He introduced the manufacture of chloride of lime in a solid state, to which he gave the name bleaching powder. His production of bleaching powder in 1799–1800 was 52 tons, the price being 140*l.* per ton. By 1835 the St. Rollox works had become the most important chemical works in the world.

**October 2, 1804.** Nicolas Joseph Cugnot died.—A military engineer and the author in 1766 of "Éléments de l'art militaire ancien et moderne," Cugnot in 1769 made the first steam-propelled road carriage, and two years later built a steam tractor for the French Government for hauling artillery. This vehicle was to carry a load of 4½ tons at 2¼ miles per hour. Though never used, this carriage is preserved in the Conservatoire des Arts et Métiers.

**October 3, 1867.** Elias Howe died.—One of the chief pioneers of the sewing machine, Howe was the son of a farmer of Spencer, Massachusetts, and was born in 1819. He began work on the sewing machine in 1841, took out a patent in 1846, and was one of the first inventors to place the eye of the needle towards the point.

**October 4, 1821.** John Rennie died.—Acknowledged as the greatest civil engineer of his day, Rennie was the builder of the London Docks, the East India Docks, the Plymouth Breakwater, Waterloo and Southwark Bridges, and he prepared designs for London Bridge. He was born at Phantassie, East Lothian, in 1761, gained practical experience under Andrew Meikle, attended the lectures of Robison and Black, and in 1789 erected the Albion Mills for Boulton & Watt, in London, the site of which was afterwards occupied by Rennie's workshops. He is buried in St. Paul's Cathedral.

**October 5, 1892.** Alexander Carnegie Kirk died.—The author of many improvements in marine engineering, Kirk, after gaining experience at Maudslay's and at Elder's, became a partner in 1877 in the firm of Napier. He was especially known for his advocacy of high steam pressure and the triple-expansion engine, the advantages of which were demonstrated in the s.s. *Aberdeen* built by him in 1882, which on a voyage to Australia showed a saving of 500 tons of coal.

**October 6, 1905.** Charles Brown died.—Brown has been called the founder of mechanical industry in Switzerland. Brought up in London, in 1851 at the age of 24 he entered the service of Sulzer Brothers, a firm of mechanical engineers at Winterthur. He established afterwards the Swiss locomotive works at Winterthur and also played a prominent part in the creation of the Swiss electrical industry.

**October 7, 1908.** Jean Baptiste Gustave Adolphe Canet died.—A distinguished armament engineer, Canet was trained at the Ecole Centrale des Arts et Manufactures, fought in the Franco-German War, and for a time engaged in railway engineering. From 1872 to 1881 he was associated with Vasseur at the London Ordnance Works, and in 1876 brought forward his theory of hydraulic brakes for checking the recoil of guns. Returning to France he became the head of armament works at Havre and after the amalgamation of these works with those of Schneider at Creusot became manager.

E. C. S.

## Societies and Academies.

SWANSEA.

**Institute of Metals, September 20.**—G. D. Bengough and J. M. Stuart: The nature of corrosive action, and the function of colloids in corrosion (Sixth Report to the Corrosion Research Committee of the Institute).—Sir Henry Fowler: The effect of superheated steam on non-ferrous metals used in locomotives. Superheated steam as used on locomotives generally leaves the superheater at a temperature of 340° C. On the Midland Railway, piston tail rod bushes were made of M.R. A.1 alloy (copper, 87; tin, 9; zinc, 2; lead, 2). A phosphor bronze (copper, 88; tin, 11; phosphorus, 1) has been found satisfactory. For piston rod packing, McNamee rings (copper, 75.5; tin, 8.5; zinc, 0.33; phosphorus, trace; nickel, 0.5; lead, 15.0) are used satisfactorily. These rings prevent the steam coming into contact with the white metal (lead, 70; antimony, 30) packing rings. With the temperature rising to 425° C. the packing rings may fuse. Piston valve fittings and cylinder relief valves are made of alloy M.R. A.1. For by-pass valves which are subjected to shock, a nickel-brass gave good service, but was replaced for economy by malleable iron or steel castings.—A. H. Munday, C. C. Bissett, and J. Cartland: White metals. The manufacture and use of white metal for industrial purposes is described, and constitution and micro-structure are dealt with only so far as the uses and manufacture are concerned. Antifriction or bearing metal, printing alloys, die-casting alloys, metals for chemical works castings, solders, are discussed.—J. H. Andrew and R. Higgins: Grain-size and diffusion. Diffusion at high temperatures may take place simultaneously with grain-growth, while at low temperatures it promotes a breakdown in the grain-size. These results have been applied to the annealing treatment of castings. It has been assumed that in the interior of the crystalline grains the system of closest packing holds, while at the boundaries the atoms in the separate grains touch only at one part of the circumference. This explains the decrease in specific gravity with an increase in the number of grains, for in such an arrangement free spaces occur. Plastic deformation, by shifting some of the atoms from their positions of equilibrium, will cause them to rearrange themselves when heated to a sufficiently high temperature. This rearrangement will be such that the stressed atoms will fall in row for row, with the unstrained atoms of the adjacent crystal. This effects a gradual migration of the grain boundary which, proceeding from every side of a crystalline unit, may result in one grain being divided up and absorbed by others. The final bounding surface will result when the boundary configuration is reached.

PARIS.

**Academy of Sciences, August 28.**—M. L. Maquenne in the chair.—L. Mangin and N. Patouillard: The destruction of the woodwork at the château of Versailles by *Phellinus cryptarum*. A detailed examination of the oak beams showed a varied fauna and flora, but *Phellinus cryptarum* is mainly responsible for the damage. This fungus has not hitherto been regarded as destructive to wood.—Jacques

**Chokhate:** The development of the integral  $\int_a^x \frac{f(v)}{x-v} dy$  as a continued fraction.—Ch. N. Moore: The equivalence of the methods of summation of Cesàro and of Holder for multiple limits.—Nilos Sakellariou: Polar systems.—Amédée Béjot: Placing in reciprocal

perspective, figures of the same species.—M. Gignoux and P. Fallot: The marine quaternary on the Mediterranean coasts of Spain.—Raoul Combes and Denise Kohler: The rôle of respiration in the diminution of the carbohydrates in leaves during the autumnal yellowing. It has been commonly held that during the change of colour of leaves in the autumn, the carbohydrates are withdrawn from the leaf and stored in the plant as reserves. It has been proved by Michel Durand that some of the carbohydrates are removed by rain, and in the present communication proof is given that part is used up by respiration and leaves as carbon dioxide.—L. Carrere: The sphincter of the iris in the selacians. This muscle in the selacians, especially in species possessing a pupil-shaped opening, is more developed at the nasal and temporal extremities of the pupil: it is less important, and may even disappear, in the ventral and dorsal sectors.—Paul Wintrebret: The mechanical polarity of the germ of selacians (*Scyllorhinus canaliculatus*) at the time of gastrulation.

September 4.—M. L. Guignard in the chair.—Théodore Varopoulos: A theorem of M. Rémoudons.—Ali. Guldberg: The theorem of M. Techebycheff.—Victor Henri and Pierre Steiner: Absorption of the ultraviolet rays by naphthalene. From a quantitative study of the absorption of solutions in hexane, ether, alcohol, and water, seventeen bands have been found between wave lengths 3207 Å and 2563 Å. These results are compared with those previously obtained for benzene by a similar method.—Erik Hulthén and Ernst Bengtsson: Researches on the band spectra of cadmium.—G. Murgoci: The classification of the blue amphiboles and of certain hornblendes.—Marcel Mirande: The formation of anthocyanin under the influence of light on the scales of the bulbs of certain lilies.—Raphaël Dubois: The destruction of mosquitos by cels. Goldfish have been suggested for destruction of mosquitos as they eat the larva, but they have the disadvantages of being costly and requiring a pure and well-aerated water. Young cels in the spring are equally voracious and devour the larvæ readily. They are more readily procurable than goldfish, and live equally well in fresh and salt water, and even in water containing sewage effluent.

#### SYDNEY.

Royal Society of New South Wales, August 2.—Mr. C. A. Sussmilch, president, in the chair.—C. E. Fawcitt and C. H. Fischer: The miscibility test for eucalyptus oils. Instead of testing the solubility by measuring the volume of aqueous alcohol required to obtain complete solution of a measured volume of oil, the critical solution temperatures with definite mixtures of alcohol and water are taken after the manner of testing fixed oils. This method is more sensitive for the indication of small changes in composition of the oil. The critical solution temperature in some cases varies markedly with time and as the oil is kept.—R. T. Baker and H. G. Smith: The Melaleucas and their essential oils, Pt. VI. Two species are discussed, *Melaleuca ericifolia*, Sm., and *M. Deanei*, Fr. M. Oil was first distilled from *M. ericifolia* by Mr. J. Bosisto in 1862, and Dr. J. H. Gladstone in 1864 determined its physical constants. The chief oxygenated constituent was thought to correspond with that in ordinary oil of "cajuput." The yield of oil obtained by the present authors was 0.8 per cent., and the chief oxygenated constituent found to be dextrorotatory terpineol, while less than 10 per cent. of cineol was present. Pinene, limonene, and a sesquiterpene were also detected. The yield of oil from young material of *M. Deanei* was also 0.8 per cent., and consisted almost entirely of pinene

with about 15 per cent. of cineol. Old leaves of this species contain very little oil.—A. R. Penfold: The essential oil from *Bachhousia myrtifolia*, Pt. I. This small tree inhabits gullies containing running water in the coast and coast mountain districts of New South Wales. Material collected at Lane Cove near Sydney, and at Currawan of the southern district, yielded 0.3-0.75 per cent. of a brown-yellow oil, varying with the time of year and locality. The oil possesses a pleasant odour and is heavier than water. Its principal constituent is elemicin (80 per cent.), a somewhat rarely occurring phenol ether. The remainder of the oil consists of  $\alpha$ -pinene, unidentified alcoholic bodies and phenols, sesquiterpene, and a paraffin of melting-point 62°-63° C.

#### CAPE TOWN.

Royal Society of South Africa, August 16.—Dr. J. D. F. Gilchrist, president, in the chair.—W. A. Jolly: The rhythm of discharge of the spinal centres in the frog. The rate of discharge of the cord in *Xenopus* at different temperatures, as indicated by galvanometric records from the gastrocnemius muscle reflexly excited, was discussed.—J. P. Dalton: On the mathematics of the homogeneous balanced action. It has been shown by the author that the integrated velocity equations of chemical reactions can be written in terms of a certain function. The same function may be employed in the treatment of the homogeneous balanced action.

#### Official Publications Received.

Western Australia. Annual Progress Report of the Geological Survey for the Year 1921. Pp. 61. (Perth.)  
Northampton Polytechnic Institute, St. John Street, London, E.C. Announcements, Educational and Social, for the Session 1922-1923. Pp. 248. (London: Northampton Polytechnic Institute.)  
New Zealand. Department of Mines: Geological Survey Branch. Paleontological Bulletin No. 9: The Upper Cretaceous Gastropods of New Zealand. By Dr. Otto Wilckens. Translated into English by the Author. Pp. iv+32+5 plates. (Wellington, N.Z.)  
Prospectus of the Royal College of Art, S. Kensington, London. Session 1922-1923. Pp. iv+29. (London: H.M. Stationery Office.)  
W. net.  
London School of Tropical Medicine. Department of Helminthology. (Collected Papers, 1922 (Part 2), Nos. 16-25. Pp. 3+4+11+7+9+75+3+7+11+5. (London: 23 Endsleigh Gardens.)

#### Diary of Societies.

##### MONDAY, OCTOBER 2.

SOCIETY OF ENGINEERS (at Geological Society), at 5.30.—C. H. J. Clayton: The Economics of Arterial Land Drainage.

##### THURSDAY, OCTOBER 5.

ROYAL AERONAUTICAL SOCIETY (at Royal United Service Institution), at 5.30.—Prof. L. Bairdson: The Work of S. P. Langley.  
CHILD-STUDY SOCIETY (at Royal Sanitary Institute), at 6.—Dr. C. W. Kimmins: Visual Humour.  
ROYAL PHOTOGRAPHIC SOCIETY, at 8.—R. H. Lawton: The Use and Misuse of Short Focus Lenses.  
CHEMICAL SOCIETY, at 8.—H. Bassett and R. G. Durrant: Cupric Tetraamine Nitrite and the Corrosion of Copper by Aqueous Solutions of Ammonia and of Ammonium Nitrate.—C. K. Ingold and H. A. Piggott: The Additive Formation of Four Membered Rings. Pt. I. Lectures on the Synthesis and Resolution of some Derivatives of Tetrahydro-1,3-Diazine.

##### FRIDAY, OCTOBER 6.

JUNIOR INSTITUTION OF ENGINEERS, at 7.30.—W. A. Tookey: Engineering in Bacon Factories.  
ROYAL PHOTOGRAPHIC SOCIETY, at 8.—F. Lambert: The Beginnings of London.

##### PUBLIC LECTURE.

##### THURSDAY, OCTOBER 5.

KING'S COLLEGE, at 5.30.—Prof. H. Wildon Carr: The New Method of Descartes and the Problems to which it gave rise (1). Succeeding Lectures on Oct. 6, 12, 13, 19, 20, 26, 27, Nov. 2, 3.

# NATURE

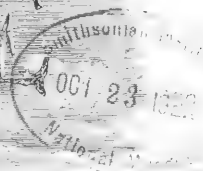

A WEEKLY ILLUSTRATED JOURNAL OF SCIENCE.

*"To the solid ground  
Of Nature trusts the mind which builds for aye."*—WORDSWORTH.

No. 2762, VOL. 110]

SATURDAY, OCTOBER 7, 1922

[PRICE ONE SHILLING

Registered as a Newspaper at the General Post Office.]

[All Rights Reserved.]

## NEWTON'S EPISCOPE

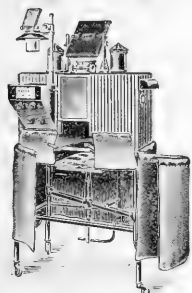

for the projection of  
**OPAQUE OBJECTS**  
including  
MAPS, DRAWINGS,  
DIAGRAMS, PRINTED  
and TYPED MATTER,  
ILLUSTRATIONS,  
NATURAL OBJECTS,  
etc.

Price list on application.

Opticians to  
H.M. the King. **NEWTON & CO.** Estab. over  
200 years.  
Specialists in Optical Projection Apparatus for Visual Instruction.  
**72 WIGMORE STREET, LONDON, W.1.**

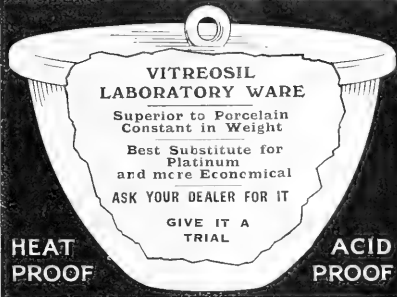

### VITREOSIL LABORATORY WARE

Superior to Porcelain  
Constant in Weight

Best Substitute for  
Platinum  
and more Economical

ASK YOUR DEALER FOR IT

GIVE IT A  
TRIAL

HEAT  
PROOF

ACID  
PROOF

SOLE MANUFACTURERS

**THE THERMAL SYNDICATE, LTD.,**

VITREOSIL WORKS—WALLSEND-ON-TYNE.

LONDON DEPOT—28 VICTORIA ST., S.W.1.

AND AT PARIS AND NEW YORK.

## BAIRD & TATE OCK (LONDON) LTD.

SCIENTIFIC INSTRUMENT MANUFACTURERS  
and LABORATORY FURNISHERS.

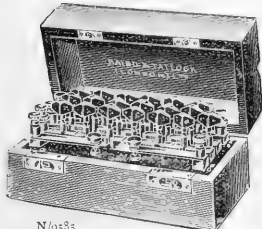

N/9585  
RESISTANCE BOX

Physical  
Apparatus  
for  
Schools  
and  
Colleges.

14-15 CROSS STREET HATTON GARDEN LONDON E.C.1



### CERTIFICATE OF EXAMINATION OF

Fahrenheit Thermometer No. 0.3050, 1871.

Manufacturer: Thermometer — Registered & Certified

Correctness to be compared to the S.W. 5012 gas thermometer by comparison with the standard instruments at the National Physical Laboratory, Teddington. The corrections are given to the nearest 0.1° F.

TEMPERATURE	ERROR
20.0	+0.1
25.0	0
30.0	0
35.0	0
40.0	0
45.0	0
50.0	0

Note: 1. — Where the sign of the correction is +, the thermometer is to be used as marked and where the sign is —, the correction is to be subtracted from the reading.  
Note: 2. — The only instrument to be used in the examination of this thermometer is the S.W. 5012 gas thermometer by comparison with the standard instruments at the National Physical Laboratory, Teddington. The corrections are given to the nearest 0.1° F.  
Note: 3. — The instrument is to be used in the examination of this thermometer as marked and where the sign is —, the correction is to be subtracted from the reading.

2m 3119 10/22/22  
10/22/22

NATIONAL PHYSICAL LABORATORY

**APPOINTMENTS BOARD**  
OF THE  
**IMPERIAL COLLEGE OF SCIENCE  
AND TECHNOLOGY,**  
SOUTH KENSINGTON, S.W.7.

EMPLOYERS requiring men who have received a thorough training in Science and Technology, and who are Diplomates or Associates of the Imperial College, or of one of its three constituent Colleges, are asked to make use of the services of the Board. No fees.

The Imperial College includes The Royal College of Science, The Royal School of Mines, and The City and Guilds (Engineering) College. The Associates of the Colleges receive thorough training in Science and Technology, including Aeronautics, Applied Optics and Optical Engineering, Electrical and Chemical Technology, Chemistry (all branches), Engineering (all branches, including Metallurgy, Mining, Mining Geology and Oil Technology), Geology, Mathematics and Mechanics, and Physics.

**THE INSTITUTE OF PHYSICS.**

**APPOINTMENTS REGISTER AND PANEL OF  
CONSULTING PHYSICISTS.**

The Appointments Register Committee is prepared to recommend to Public Departments, Universities, and Colleges, Directors of Research, Manufacturers, and others desirous of employing or consulting fully-qualified Physicists, suitable persons possessing special knowledge of any branch of physics.

By Order of the Board,

F. S. SPIERS, Secretary.

10 Essex Street,  
London, W.C.2.

**TO SCIENTISTS, RESEARCH STUDENTS, AND  
SCHOLARS.**

**THE INTERNATIONAL BIBLIOGRAPHICAL SERVICE BUREAU** supplies complete Continental and American bibliographies on any scientific, literary, or medical subject. Chemical work a speciality. Extracts made.

Headquarters: Vienna. English representative: "ALEXANDRIAN," 1A Longridge Road, Earl's Court, S.W.5.

**RESEARCH PRIZE OF \$1000.**

The ELLEN RICHARDS RESEARCH PRIZE is offered for award in the year 1923. These, by women based on independent laboratory research are eligible for competition and must reach the Committee before February 25, 1923. For circulars of information and application blank, apply to Dr. LILIAN WELSH, Goucher College, Baltimore, Maryland.

**UNIVERSITY OF BIRMINGHAM.**

**LECTURER IN PHYSIOLOGICAL DEPARTMENT.**

GRADE III.

The Council invites applications for the above post. Commencing stipend £500 per annum.

Applications, with testimonials, should be sent to the undersigned not later than October 16. No special form of application is required.

The Candidate elected will be required to enter upon the duties at once. The conditions of appointment for Grade III, and for promotion to Grade II, on the University Staff may be obtained from

GEO. H. MORLEY, Secretary.

**NORTHAMPTON POLYTECHNIC  
INSTITUTE, LONDON, E.C.1.**

The Governing Body of the Northampton Polytechnic Institute invite applications for a temporary full-time appointment as ASSISTANT LECTURER and DEMONSTRATOR in the Electrical Engineering Department; a good knowledge of mathematics is essential. Salary on the Birmingham scale according to qualifications. Forms of application, together with particulars of the appointment, may be obtained on application by letter to

R. MULLINEUX WALMSLEY, D.Sc., Principal.

**OFFICIAL SEED TESTING STATION  
FOR ENGLAND AND WALES.**

Applications are invited for the appointment of ASSISTANT to the CHIEF OFFICER in the routine work of the Station; ability to undertake research work in methods of seed testing necessary; salary £300-£350 a year according to qualifications.

Application must be made on or before October 11, 1922, to the SECRETARY, National Institute of Agricultural Botany, Huntingdon Road, Cambridge, from whom the requisite forms and full particulars are obtainable.

**AUTHORS' TYPIST.—4th year Chemical**

Student undertakes typing of scientific papers, authors' MSS., etc. Good knowledge of French and German. Box 10, c/o NATURE Office.

**BIRKBECK COLLEGE.**

(UNIVERSITY OF LONDON.)

*Principal*—GEORGE SENTER, D.Sc., Ph.D., F.I.C.

EVENING COURSES for the Degrees of the University of London in the Faculty of Science and for the Geography Diploma.

Facilities are also provided during both day and evening for Post-Graduate and Research Work.

Calendar, 1s.; by post, 1s. 5d. Prospectus free.

For full particulars, apply to the SECRETARY, Birkbeck College, Fetter Lane, E.C.4.

**CANTERBURY COLLEGE,  
NEW ZEALAND.**

Applications are invited for the position of ASSISTANT LECTURER at the above College at a salary of £500 per annum. Applicant should hold an Honours Degree in Chemistry and have studied Organic Chemistry in final year. Full particulars obtainable by sending stamped foolscap envelope to the HIGH COMMISSIONER FOR NEW ZEALAND, 415 Strand, London, W.C.2, by whom applications will be received up to October 14.

**HEADMASTER WANTED for Anglo-**

American School in France, bachelor preferred, with knowledge Mathematics and Practical Mechanics; must speak French.—Apply by letter HILDER, THOMPSON, & DUNN, 36 Jermyn Street, St. James's, London, S.W.1.

**B.A. OXFORD (22), 1st Class Hons. Natural**

Science, and 2nd Class Hons. Math. Mods., seeks appointment, Business, Research, or Teaching. Home or Abroad. Write Box No. 18, c/o NATURE Office.

**CHEMIST, B.Sc., A.I.C., desires post, 10**

years' experience as analyst, pathological chemist, and oil and cake works chemist. Box 17, c/o NATURE Office.

**BACTERIOLOGICAL INCUBATOR,**

HAERSON'S, in good working condition, with patent Gas Regulator, FOR SALE, inside measurement 15" x 15" x 18", supplied by Messrs. Baird & Tatlock. Inspection and offers invited. PROPRIETOR AND MANAGER, S/Ammonia, 30 Grosvenor Garden, S.W.

**ELECTRICAL DISCHARGE IN HIGH  
VACUUM.**

RESEARCH WORKERS should write for particulars of a varied equipment of Second-Hand apparatus, all in excellent condition, including Coils, High Tension Transformers, Rotary, Oil, and Diffusion High Vacuum Pumps, Electrical Measuring Instruments, Motors, Resistances, etc., which we can offer at very low prices.

W. EDWARDS & CO., 8A ALLENDALE ROAD, DENMARK HILL, S.E.5.  
Phone: BRIXTON 746.

**The Misses FARRAN**

10 Bell Yard, Temple Bar, W.C.2,

HAVE CONSIDERABLE EXPERIENCE IN  
**COPYING SCIENTIFIC MS.**

AND ARE PREPARED TO  
UNDERTAKE ANY QUANTITY.

**SCIENTIFIC APPLIANCES**

DALE & HOLLINS

Electrical, Magnetic, Optical Materials and Apparatus, Dynamos, Motors, Insulated Wires, Batteries, Relays, WIRELESS RADIO Parts and Fittings, Crystals, Valves, Phones, Condensers, New Duros Accumulators, do not wear out, Electric Clocks, many new articles. *New List Free.*

Lenses, Prisms, Mirrors, and all Artists' Materials and Drawing Instruments. Large stock of good Second-hand Electrical and Scientific Instruments. *Full Illustrated List 6d. post free.* See our showroom and windows, or write us. In centre of London—Top of Kingsway.

SCIENTIFIC APPLIANCES, 11 & 29 SICILIAN AVENUE, LONDON, W.C.1.





SATURDAY, OCTOBER 7, 1922.

CONTENTS.

	PAGE
Broadcasting in Great Britain . . . . .	469
The Problem of Solution . . . . .	470
The New Way of Thinking Physical Reality. By Prof. H. Wildon Carr . . . . .	471
Ceremonial Exchange. By Dr. A. C. Haddon, F.R.S. . . . .	472
Pure and Applied Electricity . . . . .	474
The Petroleum Industry. By H. B. Milner . . . . .	474
Our Bookshelf . . . . .	476
Letters to the Editor:—	
Dampier's "Discourse of the Winds" and the Distribution of Wind on the Earth's Surface. (Illustrated.)—A. Mallock, F.R.S. . . . .	478
The Conditions of Sex-change in the Oyster ( <i>Ostrea edulis</i> ).—R. Spärcik . . . . .	480
Rise in Temperature of Living Plant Tissue when Infected by Parasitic Fungus.—Dr. I. B. Pole . . . . .	480
Evans and Mary Pole Evans . . . . .	481
Coral in Medicine.—Prof. F. Jeffrey Bell . . . . .	481
Biography of Sir Norman Lockyer.—Lady Lockyer Harpoons under Peat at Holderness, Yorks.—O. G. S. Crawford . . . . .	481
A Curious Luminous Phenomenon.—S. R. . . . .	481
A Fifty-foot Interferometer Telescope. (Illustrated.) By Dr. George E. Hale, For. Mem. R.S. . . . .	482
Motorless or Wind Flight. By Dr. S. Brodetsky . . . . .	483
The Influence of the late W. H. R. Rivers on the Development of Psychology in Great Britain. By Charles S. Myers, C.B.E., M.A., M.D., Sc.D., F.R.S. . . . .	485
Obituary:—	
Prof. F. D. Brown . . . . .	490
Prof. F. T. Trouton, F.R.S. By E. N. da C. A. . . . .	490
Current Topics and Events . . . . .	491
Our Astronomical Column . . . . .	493
Research Items . . . . .	494
A Florentine School of Physics and Optics. (Illustrated.) By Dr. L. C. Martin . . . . .	496
Fruit Growing and Research . . . . .	497
Volcanic Activity in Nigeria . . . . .	497
The Royal Photographic Society's Exhibition. By C. J. . . . .	498
University and Educational Intelligence . . . . .	498
Calendar of Industrial Publishers . . . . .	499
Societies and Academies . . . . .	499
Official Publications Received . . . . .	500
Diary of Societies . . . . .	500

Broadcasting in Great Britain.

THE Postmaster-General has, it is announced, decided temporarily to suspend the issue of licences for the reception of wireless telegraphy and telephony, except to those engaged upon experimental work. In an official statement sent out by the Post Office in relation to the broadcasting situation, it is explained that the Postmaster-General has been prompted to adopt the course he has taken in connexion with the issue of licences for reception purposes owing to the fact that there has been a divergence of views concerning the details with regard to the constitution of the company which it is proposed to form for the purpose of providing the broadcasting services. Not only have the proposed articles of association of the proposed broadcasting company proved unacceptable, as a whole, to the Postmaster-General and his advisers, but also, it would appear, that differences on essential points have also been manifest between the members of the committee dealing with the Postmaster-General in this matter. Considerable progress has, it is stated, now been made towards the solution of the differences between the members of the committee in question, and, at a conference held at the Post Office on September 12, an agreement was reached as to the conditions under which the Postmaster-General will issue the necessary licences for the erection of the broadcasting stations; it therefore now only remains for the Post Office officials and the committee representing the proposed company to settle certain details.

In the official statement in question it is announced that the Postmaster-General and the committee both desire it to be known that membership of the proposed broadcasting company will not, of itself, entitle a member to use the patents of other members in the manufacture of receiving apparatus. The manner in which the broadcasting situation is being handled by the Post Office has, in some quarters, caused considerable disquietude; the policy which is being pursued by the Postmaster-General, whereby an attempt is to be made to control the broadcasting situation by and through the means of the proposed articles of association of the company which it is proposed to license to provide the broadcasting services, certainly seems to be one of doubtful wisdom. As the provisions to be included in the proposed articles of association at the instance or with the approval of the Postmaster-General have not yet been made public, it would be premature further to discuss the matter at the moment.

A point of considerable importance, which requires

Editorial and Publishing Offices:

MACMILLAN & CO., LTD.,

ST. MARTIN'S STREET, LONDON, W.C.2.

Advertisements and business letters should be addressed to the Publishers.

Editorial communications to the Editor.

Telegraphic Address: PHUSIS, LONDON.

Telephone Number: GERRARD 8830.

early attention, is the attitude the Post Office is taking in connexion with the issue of licences for experimental work. In the official statement, to which reference has already been made, it is indicated that the Postmaster-General intends in future to issue licences for experimental stations alone to those who can satisfy him that they have a sufficient knowledge of the subject to enable them to make a proper use of such licences. It is surmised in some quarters that this departmental rule has been framed with the view of restricting the grant of licences for experimental work alone to trained scientific workers. In the interests of the progress of science it is essential that the terms and conditions under which it is possible to obtain a licence for experimental work shall not be made so exacting and stringent as to exclude the amateur from the field of wireless research.

The requirements in relation to the issue of licences for experimental stations are definitely laid down in clause 2 of the Wireless Telegraphy Act, 1904 (4 Ed. 7, c. 24), wherein it is provided that "where the applicant for a licence proves to the satisfaction of the Postmaster-General that the sole object of obtaining the licence is to enable him to conduct experiments in wireless telegraphy, a licence for that purpose shall be granted, subject to such special terms, conditions and restrictions as the Postmaster-General may think proper, but shall not be subject to any rent or royalty." The language used in this clause is sufficiently clear to show that it cannot have been the intention of the legislature in any way to penalise the amateur experimentalist in connexion with the procuring of a licence for experimental work. In the matter of the grant of such licences the amateur experimentalist and the trained scientific worker have an equal claim upon the Postmaster-General, provided that they can prove to his satisfaction that the station which they desire to equip is an experimental one, in contradistinction to one fitted up for commercial work. The amateur should receive the fullest encouragement and consideration from the Post Office. Mischief will alone result should the steps which the Postmaster-General and his advisers are contemplating with regard to the issue of licences for experimental work have the unfortunate effect of moving amateurs to evade the official regulations and the provisions of the Wireless Telegraphy Act, 1904.

### The Problem of Solution.

THE problem of solution has engaged the attention of many men of science from the time of Newton to the present day, and it cannot be said that a complete

and all-embracing theory has yet been advanced that will interpret all the observed facts. The subject lends itself admirably to those who concern themselves with pointing out weaknesses of accepted conceptions without replacing these ideas by adequate substitutes.

A contributor, writing under the pseudonym Dr. B. Lagueur, in the *Chemical Age* of September 2, very ably and wittily adopts the style of the "Compleat Angler," and produces an imaginary conversation between a "Chymist" (baptised Henry), in whose chemical philosophy there has not arisen the necessity of adopting the ionic hypothesis, and a "Friend," who, being a creation of the author and therefore fundamentally of similar persuasion, is unable to make a satisfactory case for its adoption.

Of the theories advocated it is now generally recognised that the older conception of hydrate formation is insufficient to account for the experimental results obtained. The hydrone theory of Armstrong appears to be that beloved of the "Chymist," and explains solution by assuming the existence of new molecules formed by the union of the water with the solute. It has a certain measure of experimental support, but, despite this, despite the known complexity of water, and despite the crystal work of Bragg, it embodies a number of assumptions difficult to verify, and by itself is scarcely likely to displace the more firmly established hypothesis of Arrhenius, which, though revolutionary, imperfect, and easily attacked, yet fulfils the functions of a hypothesis, and therefore serves a useful purpose.

The ionic hypothesis has explained many facts hitherto extremely puzzling; it has opened out new lines of research, and "as a working hypothesis gives qualitative and quantitative explanation of a large number of chemical phenomena which can otherwise only be accounted for in a vague and unsatisfactory way." The solvate theory—a combination of the original ionic hypothesis with the hydrate and hydrone conceptions—has been the outcome of a long series of experiments on solution by Jones and his collaborators in America. The ionic hypothesis, shorn of the frills and furbelows given to it by enthusiasts, is generally accepted with certain mental reservations as to the existence of ions, except by those who, as Jones says, "oppose it after a careful study of the facts or are unable or indisposed to adapt themselves to new ideas."

Many hypotheses are at best unstable and transient, but before any are discarded they must be killed, and the death of the theory of electrolytic dissociation is not yet, notwithstanding the thrusts given to it in the article in our contemporary.

### The New Way of Thinking Physical Reality.

- (1) *The Philosophy of Humanism and of other Subjects.* By Viscount Haldane. Pp. xiv + 302. (London: J. Murray, 1922.) 12s. net.
- (2) *L'Expérience humaine et la causalité physique.* Par Prof. Léon Brunschvicg. (Bibliothèque de Philosophie Contemporaine.) Pp. xvi + 625. (Paris: Félix Alcan, 1922.) 30 frs.
- (3) *La Notion d'espace.* Par Prof. D. Nys. (Fondation Universitaire de Belgique.) Pp. 446. (Bruxelles: Robert Sand; London: Oxford University Press, 1922.) 15s. net.
- (4) *The Evolution of Knowledge.* By George Shann. Pp. vii + 100. (London: Longmans, Green and Co., 1922.) 4s. 6d. net.

THE direction which scientific research has taken in the twentieth century is imposing on philosophy a task the magnitude of which is probably not yet realised by any one. Aristotle, in his doctrine of the four causes and in his discovery of the syllogism, the logical instrument which gave that doctrine the appearance of precision, determined the type and the mode to which all succeeding scientific research right up to modern times has adhered. The essential thing in the Aristotelian doctrine is that the analysis of the physical universe proceeds in precisely the same way as the analysis of the elementary conditions which govern the production of a work of art. There is, that is to say, a matter on which an agent impresses a form in order to express an end or purpose. The modern sciences of biology and psychology had already begun to undermine this æsthetic mode of thinking reality and now the Einstein theory in mathematical physics has swept away its foundations. The result is that once more in human history physics and metaphysics are joined together. The union has been brought about by physical science itself, without any betrayal of its positive and experimental character, by fearless acceptance of the apparently paradoxical results of experiments. It is the outcome, we can now see, of a historical progress of pure science in the last three centuries, continuous in its development from Galileo to Clerk Maxwell, Mach and Einstein, which has led to a complete revolution in the way of thinking physical reality.

The philosophical current of human thought, although always a reflection of the scientific current, has not the same rhythm. It happens at times, unexpectedly and as if by a sudden explosion, that the scientific current is interrupted; some wholly unlooked-for results of experimental investigation have occurred,

and the human mind has sprung at once to the general principles whence those results proceed. A new vision of truth then opens out before human consciousness involving its whole conception of the universe and mind. It was such a vision which produced the new birth of modern philosophy in the seventeenth century. To-day a new and most startling discovery, following indeed a long historical development, but a development we can appreciate only now because the discovery has given us the vantage ground from which to look back on the history, is opening to us a new vision of truth and making us rethink our whole concept of the nature of physical reality.

(1) and (2) It is this new way of thinking physical reality which, each in his own way, the authors we have grouped together are seeking to express. In the case of Lord Haldane's "Humanism" and Prof. Brunschvicg's "L'Expérience humaine" there is full consciousness of it and a direct purpose of exposition. It is noteworthy that two such books, widely different in their method and scope and yet so singularly in agreement, both in their viewpoint and aim, should appear together. Lord Haldane, who is not a mathematician, devotes himself to detailed philosophical analysis of the new mathematical concept, while Prof. Brunschvicg, a mathematician of distinction and known to us chiefly by his *édition princeps* of Pascal's works, traces with an extraordinary grasp of details the historical development of the concept of physical causality which has resulted in the generalised theory of relativity; and both interpret to us the new concept of the physical universe in practically identical terms. The humanism of the one is the human experience of the other, and Lord Haldane's "foundational nature of knowledge" is Prof. Brunschvicg's "philosophie de la pensée."

The cosmology of Einstein differs fundamentally from every previous doctrine inasmuch as it discards both the factors which in the long history of human thought have contended against one another for pre-eminence. It regards neither the definition of the concept, whence deduction is made, nor the datum of experience, on which induction is based, as fundamental. Einstein's world is a world of figures, supposing neither *a priori* concepts nor sensible images. These figures, however, are not fictions, they are not even abstractions, they correspond to coefficients which reality furnishes. Mathematics determines for us the *invariant* which passes from one system to another.

Between Newton and Einstein, Prof. Brunschvicg tells us, there is this difference that according to Newton the thing to be measured has an absolute content, inaccessible it may be directly to man, but certainly accessible to God. That is to say, the Newtonian

universe would be an object of intuition, that is, would form a picture, at least to God. According to Einstein, we cannot say, speaking absolutely, that there is any picture even for God. The picture is only known as a function of the frame. That is, the things measured are only known through the measurements, and the measurements are bound up with the things they serve to measure. The understanding of this reciprocity makes it impossible to separate and consider apart what, for the convenience of language alone, we distinguish as frame and picture. Science goes in a kind of perpetual oscillation, with an ever-narrowing adaptation, from the measured to the measuring, from the measuring to the measured. Thus, considered from the point of view of the measuring, it is impossible by any physical means whatever to reveal a uniform movement of translation in which both the observer and all that he observes participate. Considered from the point of view of the measured, the velocity of light is the only velocity which is unchanged when we pass from one system of reference to another, and in the electromagnetic universe this velocity plays the rôle which infinite velocity formerly played in the mechanistic universe. The constancy of the velocity of light implies further an irreducible plurality of physical measurements of times, because the various groups of observers cannot make clocks from which they can detach themselves and compare them as instruments with one another. They are themselves the inhabitants of a clock, prisoners in their own time-measuring instrument, bound to its state whether they suppose it at rest or moving.

To most of us, however, whether our interest in the principle of relativity is scientific or philosophical, the greatest stumbling-block is probably the hypothesis of a finite universe. This seems a contradiction in thought and at least an unnecessary appendage of the principle. Prof. Brunschvicg shows us very clearly why the equations lead necessarily to this hypothesis, for they allow us to show that without it the total reduction of inertia to reciprocal action between masses is impossible.

The metaphysics which the new physics implies means therefore a complete revolution both in philosophy and science. As metaphysics it claims neither priority over science nor independence of it, not even the independence implied by Kant in the theory that the conditions of experience are *a priori*. This is not because metaphysics has learnt to be humble or to be resigned, but because in reality there is a contradiction in the very notion that by reflecting on science we can disengage certain antecedent conditions capable of enclosing all past and future knowledge in static schemes. On the side of positive science we have come to see that by the pure experimental method we

are not and cannot be brought into contact with elemental constituents of experience, whether material as Democritus conceived them, or intelligible as Plato conceived them, or sensible as Hume conceived them. The realities we are dealing with in physical science are statistical, so that all reflection on the results of experiment is, not an approach to the absolute, but a progress in the discovery of relativity. The early nineteenth-century ideal of a pure positive science perpetually progressive by means of a division of labour has given place in the twentieth century to a new and more subtle idea, the idea of a progress which is reflective.

(3) Prof. D. Nys's "La Notion d'espace" is a valuable book, but belongs to a different category from that of the two works we have mentioned. It is the fourth volume of his "Cosmologie ou Étude philosophique du monde inorganique," and is encyclopædic in its treatment of the subject. It includes in a general view of the various philosophical doctrines a very clear account of the recent theories with the criticisms upon them and is a model of careful compilation. It develops no original theory and is written from the point of view of neoscholasticism.

(4) Mr. Shann's short treatise on "The Evolution of Knowledge" is the work of one who knows how to think out a problem for himself. It deals with a different aspect of relativity from that of the physical principle, namely, with the nature of the vital need which has produced in man and some animals the function of knowing. All those friends of Mr. Shann who have received from him from time to time his excellent privately printed pamphlets, bound in the well-known scarlet wrapper, will welcome this published work.

H. WILDON CARR.

### Ceremonial Exchange.

*Argonauts of the Western Pacific: An Account of Native Enterprise and Adventure in the Archipelagoes of Melanesian New Guinea.* By Dr. Bronislaw Malinowski. Pp. xxxii + 527. (London: G. Routledge and Sons, Ltd., 1922.) 21s. net.

IN this volume Dr. Malinowski has given the first fruits of his extended stay in the Trobriands, a group of islands off the south-east of New Guinea. A good deal of more or less desultory information, published in Government reports and elsewhere, has indicated that these islanders differ in some respects from their neighbours; Dr. Malinowski now shows how intimately they are all associated with one another, not merely by ordinary trade, but by a hitherto unrecorded and very remarkable system of ceremonial

exchange, known as Kula, with which this book is almost solely concerned.

The exchange takes place between partners who may reside in the same island, but for the most part in different islands. The Kula articles of value are shell-necklaces of a special type and armlets made of *Conus* shell. The former always travel N.-E.-S.-W., *i.e.* clockwise, and the latter in the contrary direction, but other articles of value may be implicated in the transactions in a subsidiary manner. The islands mainly concerned in Kula are those between Nada and the Trobriands, the Amphletts, part of the southern d'Entrecasteaux and the Tubetube group. The real Kula necklaces and the arm-shells have various worth, and highly valued ones have individual names, and their wanderings are followed with interest. The ownership, or rather trusteeship, of each object is temporary, and ranges from a few minutes to one year or possibly two, but a man who retains an object beyond a year is regarded as a mean person. The exchange is by the natives sharply differentiated from barter, as no haggling takes place. An equivalent gift is always expected, but cannot be demanded or enforced, the only punishment for failing in this being loss of esteem. If at any time an equivalent gift cannot be bestowed, intermediate gifts will smooth the way till the real repayment takes place. Meanness is the most despised vice, and generosity the essence of goodness. *Noblesse oblige* is in reality the social norm regulating their conduct. This does not mean that people are always satisfied and that there are no squabbles nor even feuds about the transactions. It is obvious that however much a man may want to give a good equivalent for the object received, he may not be able to do so; and then, as there is always a keen competition to be the most generous giver, a man who has received less than he gave will not keep his grievance to himself but will brag about his own generosity and compare it with his partner's meanness; the other resents it, and the quarrel is ready to break out. All the preparatory activities, as well as those connected with the voyages and the ceremonies of exchange, are permeated by magic, as indeed is the whole economic life of the people.

The most important character of Kula is the mental attitude of the natives towards it. The objects of the Kula are neither used nor regarded as currency, as they are never used as a medium of exchange or as a measure of wealth; they serve merely to be owned and displayed and then exchanged. It is through being the means of arousing envy and conferring social distinction and renown that these objects attain their high value and form one of the leading interests in native life. The ceremonial attached to the act of giving and the manner of carrying and handling shows distinctly that they are

not mere merchandise, but something that confers dignity on a man, that exalts him, and which he therefore treats with veneration and affection. Nothing of the same kind has been described elsewhere, but something analogous may be discovered now that attention has been directed to it. The potlatch of British Columbia, for example, is worth reconsidering in the light of this book.

Dr. Malinowski has not confined himself to a mere detailed description of Kula, but he has endeavoured, apparently with great success, to explain its psychological significance. Kula so pervades the life, thought, and emotion of the people concerned in it that it seems in some respects to fulfil functions which are characteristic of many religions, but with magic supplying the place of spiritual powers. The system might almost be termed the Kula cult, as Dr. Malinowski seems to hint; but he distinctly states that the natives worship nothing.

The inter-insular Kula requires seaworthy canoes, and Dr. Malinowski describes how these are made, and the series of magical rites which accompany every stage in their manufacture, equipment, and sailing. The smaller fishing canoes are owned by one man, but the sea-going canoe is constructed by a group of people; it is owned, used, and enjoyed communally, and this according to definite rules, all of which are described with careful detail and psychological insight. To the natives a canoe of this type is a marvellous achievement, a thing of beauty, and an object permeated by magic. "He has spun a tradition around it, he adorns it with his best carvings, he colours and decorates it. It is associated with journeys by sail, full of threatening dangers, of living hopes and desires to which he gives expression in song and story. In short, in the tradition of the natives, in their customs, in their behaviour, and in their direct statements, there can be found the deep love, the admiration, the specific attachment as to something alive and personal, so characteristic of the sailor's attitude towards his craft."

An outstanding merit of this book is that it is a well-considered study in ethnographical method; indeed the author's remarks on field-work will prove of great value for the guidance of future workers. A large number of magical formulæ and oral texts is given in the native language and in translation, which provides unusual documentary evidence of exceptional value for the elucidation of native psychology. The book is well illustrated and of reasonable cost, for which the publishers are to be thanked. Mr. Robert Mond and others, by their liberality, have enabled these investigations to be made, and they have the satisfaction of knowing that they have afforded an

opportunity for a young student to produce a work of absolutely first-class value. It is to be hoped that Dr. Malinowski will be able to publish in full the remainder of his material, which, judging from this sample, will mark a distinct progress in ethnographical research and interpretation. A. C. HADDON.

### Pure and Applied Electricity.

- (1) *Einführung in die Theorie der Elektrizität und des Magnetismus. Zum Gebrauch bei Vorträgen, sowie zum Selbstunterricht.* Von Prof. Dr. Max Planck. Pp. v+208. (Leipzig: S. Hirzel, 1922.) 42 marks.
- (2) *Elettrotecnica elementare con numerosi problemi.* By A. Occhialini. Vol. 1: *Magnetismo—Elettrostatica—Elettrochimica—Elettrodinamica—Elettromagnetismo—Induzione elettromagnetica.* Pp. v+344. (Firenze: Felice Le Monnier, n.d.) n.p.
- (3) *Installations électriques industrielles: choix du matériel.* Par R. Cabaud. Pp. 316. (Paris: J.-B. Baillièrre et Fils, 1922.) 10 francs.

THE first of these three books discusses the groundwork of the theory of electricity, the next discusses the experimental laws and their laboratory applications, and the third is a severely practical work for the commercial electrician. They are all introductions to the subject, but they are intended for very different classes of readers.

(1) Dr. Max Planck's work is philosophical, and presupposes a knowledge of mathematics and of the mathematical theory of electricity which is possessed by few. The foundations on which the ordinary mathematical equations rest are examined, and particular stress is laid on the units in which they are measured. The Gaussian, the electrostatic, and the electromagnetic systems of units are considered. The work will be very welcome to the pure theorist and will increase his confidence in the soundness of the physical basis of the mathematical theory. The clear distinction made between magnetic force and magnetic induction is very convincing. The experimenter will find little that is directly helpful to him in this book, but he will appreciate, however, the author's method of getting the capacity of an ellipsoid and the deductions that can be made from it.

(2) The second work under notice is very similar to the standard English books on experimental electricity and magnetism. The author's descriptions of the main phenomena are very clear, and the numerous examples given are instructive. A very full discussion is given of the problem of a number of batteries of different electromotive forces and resistances in parallel with one another. A thorough knowledge of this

problem is a great help to students when they come to the corresponding problems of dynamos or alternators running in parallel with one another. The definition given of the temperature coefficient of metals, however, is not sufficiently accurate for modern requirements. The rating of a dynamo depends on its temperature after a run at full load, and the temperature of the coils is computed from their measured resistance and a knowledge of the temperature coefficient of copper. As the problem is one of great commercial importance it is necessary to distinguish between the temperature coefficient of the volume resistivity, the mass resistivity, and the constant mass resistance. These are all different and vary with the lower of the two temperatures considered. The approximate formulæ for the self-induction of a coil are given, but we think that their limitations should have been stated.

(3) M. Cabaud's book is very general and can be appreciated only by a technical expert. It presupposes a thorough knowledge of practical electrical engineering. In the first section of the book a general discussion is given of the kind of electric machine required to do special work; for example, whether a direct-current or an alternating-current machine will be the more useful. In the latter case also the question of whether it is to be single phase or polyphase is considered. The efficiency of the machine, its heating under load, the electric strength of the insulating wrappings, etc., have all to be considered. In the second section the characteristics of the machines, whether rotating or stationary, are described. In the last section the usefulness of the various characteristics are discussed, and the important question of the best guarantees that should be demanded from the manufacturers is considered.

### The Petroleum Industry.

- (1) *Encyclopédie Scientifique: Bibliothèque de géologie et de minéralogie appliquées: Les Gisements de pétrole.* Par Jean Chautard. Pp. viii+viii+330. (Paris: Gaston Doin, 1922.) 14 fr.
- (2) *The Oil Encyclopedia.* By Marcel Mitzakis. Pp. xvi+551. (London: Chapman and Hall, Ltd., 1922.) 21s. net.
- (3) *The Economics of Petroleum.* By Joseph E. Pogue. Pp. ix+375. (New York: J. Wiley and Sons, Inc.; London: Chapman and Hall, Ltd., 1922.) 33s. net.

THE "Encyclopédie Scientifique" constitutes a comparatively new departure in French technical literature, and has for its scope the ultimate publication of some thousand volumes dealing with the various phases of pure and applied science. M. Jean Chautard's

little book (1) is apparently one of the earliest of the series, and if it indeed sets the standard of future productions, this encyclopedia will undoubtedly prove of very great value. Well written, profusely illustrated with photographs, maps, plans, diagrams and sections, this particular volume covers a wide subject in a minimum of space. The major part is concerned with the geology of petroleum and a consideration of the petroliferous regions of the world. Other chapters deal with the nature of petroleum, natural gas and solid hydrocarbons, their origin, mode of occurrence, surface manifestations, exploration, and economic development.

The author has drawn on most of the more recent literature for his descriptions of the oil occurrences throughout the world, and in consequence the information given is most up-to-date; several minor errors occur in the spelling of place-names, but these will doubtless be corrected in a future edition. Not the least valuable of the contents of the book are the bibliography, and a noteworthy preface by M. Louis Mrazec, whose structural theories, incidentally, receive careful treatment in the text. At the present time, when scientific books are usually published at prohibitive prices, it is gratifying to be able to recommend a volume which is both an inexpensive and necessary addition to the library of petroleum technology.

(2) In the "Oil Encyclopedia," by Mr. Marcel Mitzakis, we meet with a very different type of book, one which will doubtless make its appeal more to the commercial than to the scientific community. To the many people whose province it is to control the destinies of oil-land development and economics—the administrative as distinct from the technical branch of the industry—this volume will prove of value, presenting as it does the many and varied phases of oil-mining in the form of an elaborate and explanatory index. The volume includes information of a biographical, geological, geographical, and chemical nature, apart from its treatment of the multitudinous technical factors pertaining to the oil industry, and as a source of broad reference to such matters, has much to commend it. It lacks in many cases, however, that atmosphere of authority and degree of accuracy which are to be expected in a work purporting to be for widespread use, and judged from the scientific point of view, leaves much to be desired. In several cases the definitions, especially of geological terms, are decidedly loose, if not actually erroneous, while some of the facts given are by no means correct, nor are they always up-to-date. As examples we may quote the definition of "aeolian" given as "a special kind of sand found in oil-bearing strata," and the paragraph devoted to the explanation of the word "Cambrian" since "so many oil strata

occur disseminated among Cambrian deposits." Further, the oil potentialities and realities of Great Britain are allotted space out of all proportion to their importance, while the remarks on the natural gas resources of Heathfield, Sussex, though optimistic, are unfortunately incorrect.

No work of this nature could possibly be complete, in the strict sense of the word, unless expanded into many volumes, and had the scope been a little less ambitious, the result would probably have proved far more satisfactory. The biographies could well have been dispensed with, similarly many of the definitions of the more complex chemical compounds, and thus space made available for the inclusion of many terms used in drilling, for example, which are unintelligible to the average non-technical man.

(3) The object of Mr. Joseph Pogue's book is to present, in perspective, the more important economic facts relating to petroleum, and it must be said that the author has certainly achieved his aim. He had every opportunity of producing an enormous compilation of statistics, relieved by a few terse, explanatory paragraphs and deductions, a veritable "blue-book" in fact, dreary, lifeless, and incomprehensible, as publications of that nature are usually wont to be. Instead, the author has given us a work of tangible value, one which seeks only to use past and present facts in order to foreshadow future possibilities.

People to-day are very apt to take things in general, and the petroleum industry in particular, for granted, and ignoring such factors as gradual and universal decline of oil production, more especially in the United States, they are blind to the economic situation which must inevitably be faced. Not only that, they are content to consume oil-fuel and allied products on a peculiarly wasteful scale at the present time, in a manner as complacent as it is incomprehensible to the careful thinker. We recognise in this the basis of Mr. Pogue's book. He says, "The point to be emphasized is the coming necessity for increasing the over-all efficiency of petroleum . . .", and having read that and other important observations made in his excellent preface, we are not surprised at the skillful manner in which he handles his ramified subject. The volume is very readable: indeed, it demands most careful perusal as it takes the reader rapidly from one aspect to another. Beginning with the economic organisation of the industry, it sets before us the salient features of the present trend of oil-field development, oil refinery practice, oil marketing, finance and the bearing of automotive transport on the industry, among other factors, while the chapters on resource situation, international aspects of petroleum, the full utilisation of petroleum, and the

function of statistics in the industry, are especially good.

In the space at our disposal, it is impossible to review a work of this nature with justice, and likewise to indulge in that amount of constructive criticism otherwise desired; we would suggest that, in view of its importance as an ultimate source of fuel, considerably more space be devoted to the oil-shale question in future editions, while present refinery practice might with advantage be much more severely criticised, both with regard to technique and design. The author is to be congratulated on the achievement of a remarkably fine work, one that should be widely read by all serious servants of a great industry. H. B. MILNER.

### Our Bookshelf.

*Memoirs of the Geological Survey. Special Reports on the Mineral Resources of Great Britain. Vol. 20: Lead and Zinc. The Mining District of North Cardiganshire and West Montgomeryshire.* By Dr. O. T. Jones. Pp. vi + 207. (London: H.M. Stationery Office, 1922.) 7s. net.

LIKE the three previous volumes dealing with British lead and zinc ores which have been issued by the Geological Survey, it must be admitted regretfully that the present one has a scientific rather than an economic interest. Some of the mines described in the present volume, like Frongoch mine in Cardiganshire and the Van mine in Montgomeryshire, have been extraordinarily productive; the former has been worked for 59 years and the latter for 51 years, and from each more than 100,000 tons of lead and zinc ores have been produced in the course of its career, but in both cases the really productive period was something like half a century ago. The author suggests that it is just possible that these mines might show an improvement by sinking deeper and reaching harder rocks than the soft shales in which they are now bottomed; the prospect, however, is not a very promising one, and the present low price of lead affords no encouragement to spend money on prospecting operations of a highly speculative nature.

The real value of the present work lies in the excellent study of the formation of the faults and fissures and the mode of their filling which Prof. Jones has supplied in the introductory chapters. The first chapter on the general structure of the area gives a very valuable summary of its leading geological features, while the next two chapters are devoted to a discussion of the leading system of fissures to which the district owes its mineral wealth. Finally, the last chapter deals with a number of important points such as the probable age and sources of origin of the ore filling, and the influence upon it of the country rock traversed by the fissures. These chapters form a most valuable contribution to the study of mineral deposition, and from this point of view, quite apart from any possible remote economic possibilities, Prof. Jones's volume deserves the careful attention of the student of mineral deposits. H. L.

*Some Scottish Breeding Duck: Their Arrival and Dispersal.* By Evelyn V. Baxter and Leonora J. Rintoul. Pp. vii + 90. (Edinburgh: Oliver and Boyd, 1922.) 5s. net.

THE problems of the increase and extension of range of ducks in Scotland, and in other countries, have long exercised ornithologists throughout the British Isles. As the authors of the volume under notice point out, protection and a better feeling towards and a greater interest in all wild birds are probably important factors in the case but do not explain everything. Certain species other than ducks are as steadily decreasing, and the rise and fall of a species is a complicated biological problem which may have but indirect association with human interference, or may be due entirely to other causes. The recent colonisation of Scotland by other birds, such as the starling, turtle-dove, and great-crested grebe, may be due to the necessity for an over-abundant species to find new areas and the possibilities of settling in an area where raptorial birds and other enemies have been largely destroyed by man's advance and action.

One factor the authors have not stressed, the growing habit of keeping pinioned ornamental fowl, though they mention bird sanctuaries. Passing birds are often "called down" by pinioned fowl, and some of them may elect to mate and breed. That the direction of spread differs in such ducks as the gadwall and wigeon is no argument against this fact, for the source whence come the visitors has no bearing on the influences which cause them to remain. Many pairs of ducks of various kinds have probably nested in out-of-the-way places for years and been overlooked, for it is only within the last thirty years or so that parts of Scotland have been systematically explored from the ornithological point of view. Sportsmen and keepers are not very particular about the species of the ducks which fill their bags.

We note that the authors use the correct spelling of two much-discussed names, wigeon and shoveler.

*An Introduction to Engineering Drawing.* By J. Duncan. (Life and Work Series.) Pp. x + 158. (London: Macmillan and Co., Ltd., 1922.) 4s.

THE aim of Mr. Duncan's book is to enable young students of engineering to produce intelligible working drawings of the details of engineering machines and structures. The student is introduced to the proper workmanlike methods of actual engineering practice, and is not allowed the use of any special hybrid methods which are supposed by many to be sufficient for use in schools.

The book commences with a description of drawing instruments, their use and handling; from this, the student is led to the ordinary problems in plain geometry with practical engineering examples such as drawing cams, and plotting small surveys. Afterwards, a little solid geometry introduces the student to oblique and isometric projection, and prepares him for the drawing of engineering details. For this latter portion of the training the author strongly recommends the use of models. A commencement is made with simple fastenings such as bolts and nuts, then the more complicated connexions are dealt with, as exemplified



in tie bar joints, cotter joints, and coupling boxes. The following chapters deal in succession with other engineering details, such as belt and rope pulleys, chain drives including sprocket wheels, bearings of various kinds, and details of shafting, cylinders, and pistons. Finally, structural details involving the usual angles, tees, and channels with the more elaborate columns, girders, and roof truss joints in which the sections are employed give the student a useful introduction to this side of engineering practice.

The book covers much ground in its 158 pages. It is very clearly written, and the publishers' part, in so far as concerns the type and diagrams, is quite perfect. For the purpose of familiarising the budding engineer with the elements of machines and structures the author has produced a most excellent book.

*Juvenile Delinquency.* By Henry Herbert Goddard. Pp. vi + 120. (London: Kegan Paul and Co., Ltd., n.d.) 3s. 6d. net.

No student of modern life can fail to be perturbed by the number of juveniles who come before the courts yearly for offences covering a very wide range. That our present system does not deal with them adequately is obvious.

Delinquent behaviour is fundamentally unsocial behaviour, *i.e.* the child is obeying his own instincts instead of modifying them according to the demands of society. It becomes therefore necessary to ask why a child behaves unsocially. These unsocially behaved children fall into at least two groups, (a) those who are mentally too unintelligent to understand social behaviour; and (b) those known as psychopaths, who, while having normal intelligence, have not normal control.

The author suggests that these children should be cared for by some bureau organised by the State, which should undertake research work, be able to diagnose cases before the behaviour has become seriously wrong, and also to control the lives of those who will never be able to control them for themselves. He describes in this connexion the Ohio Bureau of Juvenile Research which, although only established in 1914, has yet justified itself by its work.

*Outwitting our Nerves: A Primer of Psychotherapy.* By Dr. Josephine A. Jackson and Helen M. Salisbury. Pp. viii + 403. (London: Kegan Paul and Co., Ltd., n.d.) 7s. 6d. net.

THE stream of books concerned with explanations of modern psychologists in general, and of Freud in particular, for people of little or no psychological knowledge, still flows on. Many fall entirely in their avowed object, being either too condensed to be intelligible, or too popular to be scientific. The effect of a conversion to Freudian doctrines is, only too frequently, of the nature of a wholly uncritical acceptance of much that Freud would call problematical. It is therefore a relief to turn to this book, which not only gives a very fair and balanced account of the findings of psycho-analysis, but also keeps these findings in perspective, showing them in relation to the known laws of biology and psychology. The whole book is characterised by a sense of humour foreign to many writers on the subject, and by sanity of outlook. Written in

an easy and popular style it can be safely recommended to the student of, or sufferer from, "nerves," and even to the reader already cognisant with the literature of psycho-analysis it will prove helpful and interesting.

*Imperial Institute: Monographs on Mineral Resources with Special Reference to the British Empire: Silver Ores.* By Dr. H. B. Cronshaw. Pp. ix + 152. (London: John Murray, 1921.) 6s. net.

THIS addition to the useful Imperial Institute Monographs gives details and statistics of the sources of silver throughout the world. In 1918 the British Empire produced nearly one-fifth of the world's supply, Canada being responsible for the larger part of this amount. The United States headed the list of producers during the war period, but has now been passed again by Mexico. About two-thirds of the world's silver comes from base metal ores, and much of the remainder is obtained from ores worked primarily for gold, so that silver is mainly a by-product of other metallurgical operations. The extraction and uses of silver are dealt with only very briefly in this monograph, and some information as to the metallurgical processes employed in the most important mining regions would have added to its value. This remark applies particularly to the account of the rich and metallurgically interesting Cobalt district of Ontario, which is responsible for the greater part of the Canadian production. These monographs provide much information in a handy form.

*A Systematic Qualitative Chemical Analysis: A Theoretical and Practical Study of Analytical Reactions of the more Common Ions of Inorganic Substances.* By Prof. G. W. Sears. Pp. vi + 119. (New York: J. Wiley and Sons, Inc.; London: Chapman and Hall, Ltd., 1922.) 8s. 6d. net.

THE introductory part of the work under notice contains a brief account of such matters as equilibrium, ionisation, and solubility product. The section on the detection and separation of the metals is in the form of numbered experiments, and is much less clear and useful than the usual arrangement in tables. The explanations of the reactions, however, are very clearly and fully described, and would be useful in supplementing analysis tables. The section on acids relies on precipitation methods with a single sample, and all preliminary tests are omitted. This seems to be a mistake, as many acids are readily found by simple preliminary methods. There appear to be no features which would indicate any marked superiority of the book over existing treatises.

*An Introduction to the Chemistry of Radio-Active Substances.* By Dr. A. S. Russell. Pp. xi + 173. (London: J. Murray, 1922.) 6s. net.

THERE is at present a real need for a small but up-to-date book on radioactivity, in which the subject is dealt with from the chemical as well as the physical side. Dr. Russell's book would seem to supply this need very satisfactorily. It is not overburdened with detail, but gives a balanced account of the subject, which will be found very useful to students. A particularly good feature is the inclusion of the chemical methods of separation and analysis, which sometimes tend to get lost in theoretical speculations.

### Letters to the Editor.

[The Editor does not hold himself responsible for opinions expressed by his correspondents. Neither can he undertake to return, or to correspond with the writers of, rejected manuscripts intended for this or any other part of NATURE. No notice is taken of anonymous communications.]

#### Dampier's "Discourse of the Winds" and the Distribution of Wind on the Earth's Surface.

DAMPIER'S "Voyages" are well known, at any rate by name, but his "Discourse of the Winds" is seldom referred to. It is, however, well worth careful examination and, so far as I can judge, contains as

rule are not of the type who place their knowledge on record. With the "Discourse" Dampier publishes maps of the hemispheres in which his observations are summarised.

For his purposes he divides the earth's surface into four regions, namely, the two trade wind areas and those to the north and south of them. These latter he calls the "Regions of Variable Winds." The directions of the trades are indicated in the maps by lines and arrows, but naturally and rightly the regions of variable winds are left blank.

No indication is given of the directions of the wind on land, but what he calls coastal winds, that is winds the direction of which is influenced by the proximity of land, are shown in some detail.

Parts of the maps are here reproduced (on the

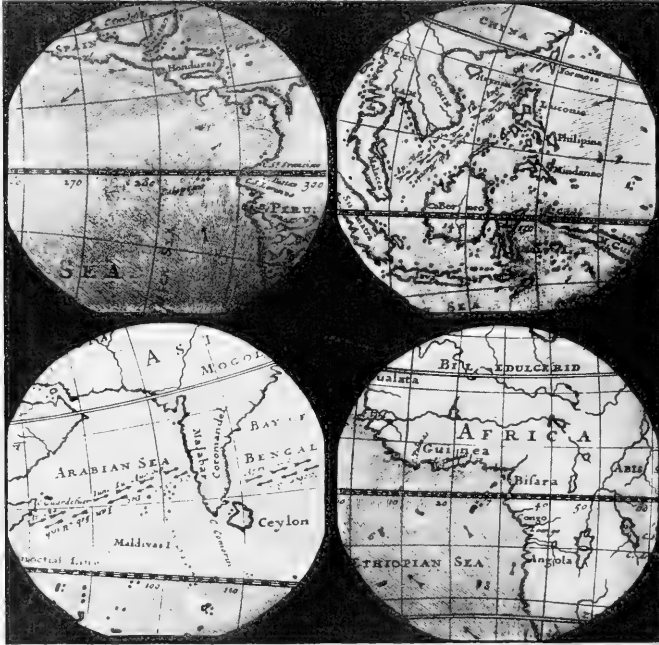

FIG. 1.—Reproduction of parts of Dampier's Maps to show coastal winds in the Trade wind areas.

much information about the distribution of winds as any of the modern works on the same subject.

In this "Discourse" Dampier propounds no theories, but aims at setting down the general character of the winds encountered by ships in all parts of the world, using for this purpose his own observations, and such other information as he has gathered from sources which he considers trustworthy.

It must be remembered that in Dampier's time (late seventeenth and early eighteenth centuries), the ships employed even for the longest voyages were small, and the direction and strength of the prevailing winds were much more important to navigators than they are at the present time. It is true that there are still plenty of small sailing craft in various parts of the world, the captains of which are probably well acquainted with local conditions, but these men as a

whole are not of the type who place their knowledge on record. With the "Discourse" Dampier publishes maps of the hemispheres in which his observations are summarised.

For his purposes he divides the earth's surface into four regions, namely, the two trade wind areas and those to the north and south of them. These latter he calls the "Regions of Variable Winds." The directions of the trades are indicated in the maps by lines and arrows, but naturally and rightly the regions of variable winds are left blank.

No indication is given of the directions of the wind on land, but what he calls coastal winds, that is winds the direction of which is influenced by the proximity of land, are shown in some detail.

Now let this earth be warmed by a source of heat equivalent to the sun, but in the form of a distant ring surrounding it in the plane of the equator. Let the atmosphere be transparent to radiation and take its heat only from the floor of the cell which contains it.

In the course of time the contents of each cell will reach the temperature of the floor, which will be a maximum at the equator, and will vary as the cosine of the latitude to absolute zero at the poles.

The barometric pressure in each cell will be the same; were all the cells removed the atmosphere would be in equilibrium. The equilibrium, however, would be unstable, and the least departure from the original stratification of density would cause ultimately a circulation to be set up, in which, in the absence of turbulence, warm air would flow from the equator towards the poles at high levels, while cooled air would travel in the opposite direction near the surface of the earth. A steady distribution of temperature would be reached when each element of the surface lost by radiation as much heat as it received from the source plus that supplied by the circulation, and this distribution probably would not differ much from that which now exists, though the fact that the real atmosphere is more or less opaque to long waves would introduce a sort of "green-house" effect, and raise the mean temperature above that appropriate to perfect transparency. Again if the imaginary earth were completely covered by a deep ocean, a separate circulation would be set up in the latter, and the temperature distribution would be somewhat modified in the direction of greater uniformity.

Since the energy of the circulation is derived from the source of heat, there will be no change of pressure due to the velocity, and supposing for the moment that the air is incompressible, then in the nearly horizontal path which constitutes the greater part of each stream line circuit, the cross-section velocity and dynamic head for each will be constant, though not necessarily the same for different streams. The cross section of the ascending and descending parts of the streams will bear to the cross section of the horizontal part the ratio of the length of the earth's quadrant to the height of the homogeneous atmosphere, and thus in the neighbourhood of the poles and the equator there will be a small increase of pressure. The form of the stream lines due to temperature circulation in a spherical shell is indicated diagrammatically in Fig. 2.

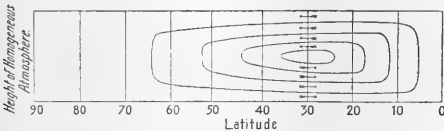

FIG. 2.—Stream lines of the circulation in a meridional element of a spherical shell, the density of the fluid being supposed constant.

As regards the distribution of temperature, the results would be much the same whether the earth were stationary or rotating, but the direction and velocity of the wind referred to a fixed point on the solid surface would be very different in the two cases. If, in the absence of surface friction, the earth were given its present angular velocity the apparent wind would have an easterly component of about 1000 miles per hour at the equator while at the poles there would be a calm. If, on the other hand, when the rotation was started, the air was given the same velocity as the surface under it, the apparent wind would vary in direction and force in a period equal to that of the circulation.

In the real atmosphere, the effects of turbulence,

viscosity, and surface friction will ensure that the average velocity of the apparent wind shall in no place exceed 30 or 40 miles per hour. If unresisted air passes from lat.  $\lambda$  to  $\lambda + \Delta\lambda$  the change of the linear speed of the ground under it, *i.e.* the change in the E. or W. component of the apparent wind, is  $R\Delta\lambda(1 - \sin\lambda)$  linear velocity in longitude, and if the apparent wind remains constant, it shows that surface friction is sufficient to accelerate or retard the atmosphere by this amount in the time taken in covering the distance  $R\Delta\lambda$ . In the case of the earth, this would imply that if the circulating velocity (*i.e.* the N. or S. component) is 15 m.p.h., surface friction suffices to change the speed of the apparent wind by about 15 m.p.h. per hour near the poles while in lat.  $30^\circ$  the corresponding change would be somewhat less than 2 m.p.h. per hour.

On the imaginary seasonless earth, the average wind would everywhere be a definite function of the latitude and coefficient of friction, provided that the going and returning parts of the circulation did not mix on the journey, and in low latitudes this would be true even when the effects of turbulence were taken into account. Farther north or south, however, the hot and cold streams would become interwoven in eddies the forms of which are incalculable, though the average winds would always be either from N. and E. or S. and W. Thus it might be expected that there

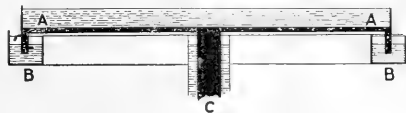

FIG. 3.—AA, Circular conducting plate and tank. BB, Annular hot water trough. C, Axis and cold-water tank.

would be calms at the equator, moderate and regular trade winds for some distance on either side, and beyond these, irregular winds, the intensity of which increased with the latitude. The barometric pressure would be nearly constant except in the eddies, and there the variation of pressure would depend, not on the actual velocity of the apparent wind, but on its difference from the average for the latitude.

Such a description with modification depending on the seasons, the presence of moisture in the air, and on the distribution of land and water agrees with the average conditions on the real earth. Dampier's maps show that coastal influence may be sensible through  $10^\circ$  of longitude or more, and it may be guessed that the direction of the monsoons is in some way influenced by the great area of land lying to the north of the parts where they blow.

There is not much information available concerning the wind structure of the atmosphere on the borders of the Trades, and a proper investigation of this subject would form an important addition to meteorological science; but such an investigation would require more than one *Challenger* expedition devoted to the exploration of the upper air instead of the deep sea.

Expeditions of this kind are not likely to be undertaken at the present time, but some notion of the manner in which the Trades break up might be gained by an experiment such as is indicated in Fig. 3, where a thick circular metal plate, provided with descending flanges at the circumference and a thick central axis, carries a shallow circular tank containing fluid. The flanges dip into a circular trough of warm water while the axis is kept cold. If the apparatus is stationary, a circulation is set up in the tank of the type shown in Fig. 2, but if it has an appropriate angular speed about the axis, the

conditions will have a certain similarity to those existing in the atmosphere. The difference in the character of the circulation in the two cases could scarcely fail to give some useful hints.

Another illustration of the kind of flow to be expected near the borders of the Trades may be observed (although the analogy is not so close as in the experiment) whenever a current of water flows into a pond. The central part of the stream continues on its course for some distance unbroken, but the margins are bordered by eddies, which (looking down stream) are right-handed on the right, and left-handed on the left side, and consist of equal volumes of water from the stream and from the pond wrapped together after the fashion of a "roly-poly" pudding. When once formed, they have a certain life of their own, and follow erratic courses, often generating secondary eddies further from the main stream. In general their life is short, but occasionally vertical components in the flow of the main stream give rise to components in the eddies parallel to their axes, and in such cases the vortices may be sustained and intensified.

Much the same sort of action must be going on at the borders of atmospheric currents, and it must happen, especially in the turbulent regions, that either on account of the general circulation or from local causes, warm air will sometimes underlie colder strata, and this is what is required to prolong the life of eddies or vortices with vertical axes.

It may be said with some confidence that tornadoes, sand pillars, and waterspouts are due to local causes of this kind, and it seems highly probable that the deep barometric depressions which accompany the greater storms have a similar origin depending on inversions of level of the general circulation. In referring to warm and cold strata, the temperature must be supposed to be compared at the same altitude since, so far as thermometric readings are concerned, the upper air is always colder than that near the ground.

A. MALLOCK.

9 Baring Crescent, Exeter,  
August 10.

#### The Conditions of Sex-change in the Oyster (*Ostrea edulis*).

IN the issue of NATURE for August 12, p. 212, and in several previous numbers, Dr. Orton has given some interesting information concerning the old question of the breeding habits of oysters, especially sex-change and its conditions. This problem has been discussed in a certain number of ancient treatises (Davaime, Van Beneden, Lacaze-Duthiers, Hoek, etc.), but has been but little investigated in the course of the last few years. During my work at the Danish Biological Station I have, since 1910, been making experiments and investigations on the biology of the oyster in the Limfjord. As my results in several respects confirm and amplify those of Dr. Orton, I will give here a short account of some of the most important. In the course of the winter a more detailed paper will probably be published in the Report of the Danish Biological Station.

Dr. Orton confirms the observation, made by Möbius, that in European oysters a specimen directly after breeding produces spermatozoa, and I fully agree with him. In several cases I have proved, through experiments with oysters, in the shells of which a little hole had been bored, that an oyster in the course of less than a week changes from a female to a male.

Dr. Orton further mentions the interesting fact that he has been able to state that an oyster born in 1921 was spawning already in 1922; this phenome-

non he ascribes, and very rightly, to the high temperature of the summer 1921. I have investigated several thousand oysters in the Limfjord: the youngest female found by me was at least three years old, which is no doubt due to the lower temperature of the Limfjord. Neither did I ever find that oysters had ripe spermatozoa in the summer in which they were born; in the Limfjord that phenomenon only occurs in the following summer. Formerly the earliest time for an oyster to breed was much discussed. If we examine from where the different authors have obtained their material, it appears that those who advocated early breeding had got theirs from Southern France, while those who advocated two to three years as the age for breeding had had material from the English Channel and the North Sea.

From my experiments, and from the study of previous papers on this subject, I have come to the conclusion that the duration of the male stage depends on temperature, so that the colder it is the longer the stage lasts. At the temperature which ordinarily prevails in the Limfjord (15°-16° in July), this stage will last three to four years. The oyster, therefore, breeds for the first time (the first stage being the male stage) when it is three to four years old; further, every single oyster individual in ordinary circumstances of temperature breeds only every third or fourth year, in especially cold years still less often, in warm years more often. These phenomena, together with the shorter duration of the female stage, explain the fact that in a certain number of oysters in the Limfjord we always find only a relatively small percentage of females. This likewise explains why the oyster breeds more sparingly the further north it is, and decreases regularly in number without any sharp boundary-line.

The breeding of the oyster is in at least three respects influenced by temperature. A high temperature increases the number of times an oyster may breed in its life, it shortens the time which the breed passes in the mantle of the mother animal, and, according to Hagmeier, it shortens the pelagic larva stage.

R. SPÄRCK.

Copenhagen, September 5, 1922.

#### Rise in Temperature of Living Plant Tissue when infected by Parasitic Fungus.

WHILE engaged on some work connected with the export of citrus fruits from South Africa to England, we have come across a point of interest to plant pathologists and bacteriologists which would seem worth recording at this stage.

In investigating the effects of inoculating oranges and grapefruit with *Penicillium digitatum* we found that a very definite rise of temperature took place in the infected tissue. We are not aware of such an observation having been made before in connexion with the invasion of plant tissue by a parasitic fungus, and it will be interesting to ascertain whether a similar rise of temperature takes place in all cases where living plant tissue is attacked by parasitic fungi or bacteria.

To what extent direct reaction of the host is responsible for the rise of temperature is still to be determined; certainly no rise of temperature was observed when the host tissue was killed prior to inoculation. Mercury-in-glass thermometers were used in making these observations, but the employment of thermo-electric apparatus will naturally be necessary to carry the investigations further.

This observation of ours would seem to open up

an entirely new field for research by botanists, and it is probable that it may have an important bearing on the problem of fruit and vegetable transport and storage.

An account of the experiments undertaken to illustrate the above will be published in due course.

I. B. POLE EVANS.  
MARY POLE EVANS.

Office of the High Commissioner for the  
Union of South Africa,  
Trafalgar Square, London, September 22.

#### Coral in Medicine.

IN the serious contributions published in recent issues of NATURE on the subject of black coral, no one seems to have remembered that in the "Médicin malgré lui" Molière makes Sganarelle offer a medicinal cheese to Perrin for his mother, thus:

P. Du fromage, monsieur ?

S. Oui ; c'est un fromage préparé, où il entre de l'or, du corail et des perles, et quantité d'autres choses précieuses.

And Sganarelle's last words are, "Si elle meurt, ne manquez pas de la faire enterrer du mieux que vous pourrez."

F. JEFFREY BELL.  
September 20.

#### Biography of Sir Norman Lockyer.

MISS LOCKYER and I are preparing a biography of my husband, Sir Norman Lockyer, in a form which I hope will make it not only of interest to his many friends and admirers, but also a contribution to the scientific literature of the present day. If any readers of NATURE happen to possess letters from my husband, I should be greatly obliged if they would give me the opportunity of seeing them. My object in making this request is that any matters of general interest which thereby come to light might be incorporated in the work.

The letters would not be quoted, except with the permission of their owners, and would be returned as soon as their contents had been noted.

T. MARY LOCKYER.

Salcombe Regis, Sidmouth,  
September 22.

#### Harpoons under Peat at Holderness, Yorks.

AT the recent meeting of the British Association at Hull there was a very lively discussion at Section H about some harpoons said to have been found under peat in Holderness. May I ask you to be so good as to spare a little space, in order that I may say more fully what time prevented me from saying then ?

There is a doubt about the authenticity of those harpoons. Mr. T. Sheppard believes them to have been made by the supposed finder; Mr. A. L. Armstrong, who introduced them to the meeting, believes them to be genuine. I also believe one of them to be genuine, the smaller of the two; about the other I am not so sure. But I expressed no opinion as to whether, if genuine, they were found locally or not, since I have no means of forming an opinion. It is possible that they—or the smaller of the two—were found in archaeological excavations abroad; and a fictitious site in Yorkshire given to them later to enhance their interest.

Mr. Sheppard quite rightly says that the discovery

of a flint axe of a certain type "in the neighbourhood" proves nothing. But I understood that it was found under a depth of peat. In type it is Campignian, exactly what one would expect to find associated with harpoons of early neolithic type.

There can be little doubt that in Holderness exist remains of the early neolithic age, remains which are older than the Long Barrows. Apart from surface-finds, the pile-dwellings or platforms at Ulrome are evidence of the existence of habitations there which seem to be neolithic; they contained stag's-horn axes of a well-known early neolithic type—though it is true that type survived right through the neolithic period on the continent. There is thus no *a priori* reason for rejecting the harpoons; they are just what I have always expected would be found in Holderness.

However, we cannot use suspect material as evidence, and the best thing to do is to go into the field and test it. If Mr. Armstrong will find a site where flint flakes and implements are to be found under the peat in sufficient numbers to justify digging, I will come and bring a spade with me.

O. G. S. CRAWFORD.

Ordnance Survey Office, Southampton,  
September 18.

#### A Curious Luminous Phenomenon.

I HESITATE to trespass on your space in describing an observation which may be more common than I suppose.

While standing about twenty yards from the seashore and looking due south out to sea, the horizon and a region slightly above it (elevation only about 1° or 2°) were lit up by a faint white light which extended laterally over a segment subtending an angle of about 30°.

The conditions under which this light was seen were as follows: Time, 7.15 P.M.; wind strong from the west, bringing up a good deal of low cloud and very fine rain in the air causing bad visibility; sea rather rough with four lines of breakers at the shore. The appearances of the light were not the same to my wife as to myself. Her impression of it was that it was a light which she saw only if her eyes followed it, yet it consisted of a long streak of light parallel to the horizon with a break in it and then another small streak. My impression was that of a light which appeared to flash up over the horizon, subtending the angles already noted, the flashes not succeeding each other regularly. I had the feeling that my eyes had to be just right for getting the impression at all.

As to the cause, I think we can eliminate that of distant lightning; the weather had not been for many days of a thundery type, and it is unlikely that distant flashes would light up a streak of the distant sky embracing such a wide lateral angle and yet be restricted to an elevation of not more than 2°.

The sky above the horizon was darkly and uniformly clouded at the time, so that the horizon was barely visible, but white-capped waves could be seen far out at sea. The brightest objects in the field of view were the lines of breakers at the shore, and it may be that the retinal images of these being very near to that of the horizon were the cause of the phenomenon. Perhaps some readers of NATURE are familiar with this sort of observation and will point to the obvious cause.

S. R.

Aldwick, Sussex,  
September 16.

### A Fifty-foot Interferometer Telescope.<sup>1</sup>

By Dr. GEORGE E. HALE, For.Mem.R.S.

THE angular diameter of a star was measured for the first time by Mr. Francis G. Pease at the Mount Wilson Observatory on December 13, 1920, with a 20-foot Michelson interferometer attached to the 100-inch reflecting telescope. The method employed is due to Prof. Michelson, who had adjusted

21,000,000, 270,000,000, and 400,000,000 miles respectively. These stars are all in the giant stage, with densities ranging from 0.000001 (Antares) to 0.0002 (Arcturus). The Sun, a dwarf star 866,000 miles in diameter, in a much more advanced state of development, has a density of 1.4 (water = 1).

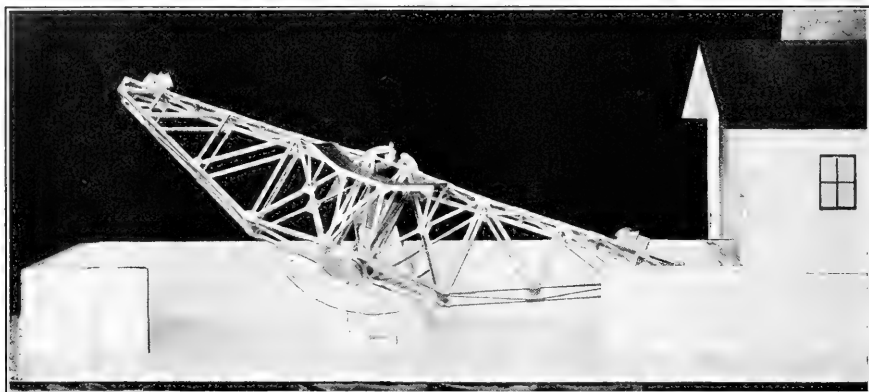

FIG. 1.—50-foot interferometer telescope for the Mount Wilson Observatory. Model seen from the north (part of wall removed to show 36-inch mirror cell and driving mechanism).

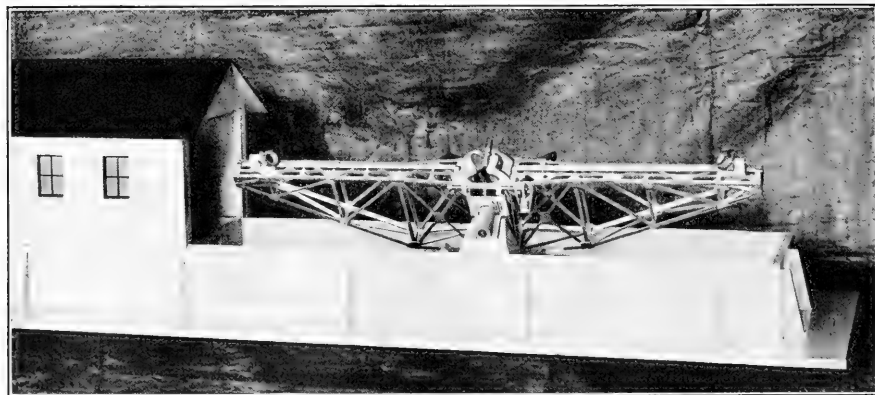

FIG. 2.—50-foot interferometer telescope for the Mount Wilson Observatory. Model seen from the south, showing movable house that covers the instrument when not in use.

the interferometer and tested it on stars during the previous summer, with the assistance of Mr. Pease. Since that time Mr. Pease has measured the diameters of Betelgeuse, Arcturus, Aldebaran, and Antares. On the basis of the best available values of their parallaxes, the corresponding linear diameters are 215,000,000,

<sup>1</sup> The substance of this article was communicated to Section A of the British Association at Hull on Monday, Sept. 11, by Prof. H. H. Turner, who showed the photographs of the model on the screen.

It would evidently be of great interest to measure the diameters of other stars, of various spectral types, because of the direct bearing of the results on the problem of stellar evolution. Unfortunately, very few are within the range of the 20-foot interferometer, and neither the capacity of the telescope mounting nor the width of the observing aperture in the dome will permit a larger instrument to be used with the 100-inch re-

flector. Immediately after the first successful measures by Mr. Pease, both he and I made several designs of large interferometers with independent equatorial mountings, but their cost would have been too great to warrant their construction. It was also thought advisable to postpone further instrumental developments until they could be undertaken in the light of prolonged experience with the 20-foot interferometer.

The method has since proved so successful, and its wider application so desirable, that the mechanical problem has recently been taken up anew. Optically the 20-foot instrument leaves nothing to be desired. The new instrument is therefore simply a larger Michelson stellar interferometer adapted for the observation of fainter and smaller stars, embodying no new optical features, but carried by a mounting so simplified in design as to reduce the cost of construction to a minimum. My specifications for the mounting, which have been improved in certain respects and developed into working drawings by Mr. Pease and his associates in the Division of Instrument Design of the Mount Wilson Observatory, call for a light but very rigid skeleton girder about 54 feet long and 10 feet deep at its centre, where its cross-section is about  $4\frac{1}{2}$  feet (Figs. 1 and 2). This is to be built of standard steel shapes, cut to length at the mill and riveted together on Mount Wilson. The girder will be bolted to a heavy plate carried by the upper extremity of the polar axis, which is a short steel forging turning in standard roller bearings, mounted on the upper face of a massive concrete pier. The polar axis passes through the centre of gravity of the girder, thus assuring its balance in all positions. A worm-gear sector of long radius, bolted to the girder, is driven by a worm connected with a driving-clock fixed near the north face of the pier. The range of motion in right ascension is  $1\frac{1}{2}$  hours east and west, thus allowing ample time for the observation of a star when near its meridian passage.

The optical parts comprise a paraboloidal mirror of 36 inches aperture and about 15 feet focal length, mounted within the girder, as shown in the illustrations. The two outer plane mirrors, each 15 inches in diameter, mounted at  $45^\circ$  on carriages which slide along rails

bolted to the upper face of the girder, receive light from the star and reflect it to two similar  $45^\circ$  plane mirrors, fixed in position above the 36-inch mirror, to which they send the two parallel beams. These are returned as converging beams toward the focus, but are intercepted by a (Newtonian)  $45^\circ$  plane mirror above the centre of the girder, which sends the light to the focal plane, in the direction of the north pole. The observer, seated on a platform carried by the girder, makes the necessary adjustments and determines the visibility of the interference fringes corresponding to various settings of the outer  $45^\circ$  mirrors, which are periodically moved apart by a single long screw driven by an electric motor. The distance between these mirrors, when the fringes disappear completely, gives the angular diameter of the star if the mean wave-length of its light is known.

To reach stars north or south of the equator, the two outer  $45^\circ$  mirrors are rotated simultaneously by synchronous motors about the axis joining their centres. In this way any star from the pole to  $30^\circ$  south declination can be observed when near the meridian.

Throughout the design precautions have been taken to reduce the amount of large and expensive machine work to a minimum. The girder need be only approximately straight, as the rails, carefully planed in 12-foot lengths (the limit of our planer bed), will be optically lined up by adjusting screws. The final compensation for length of path will be effected by a sliding wedge, of the type designed by Prof. Michelson for the 20-foot interferometer. Comparison fringes, adjustable for visibility, will be provided as an aid to the observer. The instrument will be covered when not in use by a sheet steel house with double walls, the upper part of which can be rolled away longitudinally by an electric motor.

This interferometer should permit the measurement of more than thirty stars brighter than the fourth magnitude, representing a wide range of spectral types. It is now under construction in the instrument and optical shops of the Mount Wilson Observatory.<sup>2</sup>

<sup>2</sup> For a brief account of the 20-foot interferometer and its method of operation, see the chapter on "Giant Stars" in the writer's recent book "The New Heavens," reviewed in NATURE of July 11, p. 2. Full details are given by Messrs. Michelson, Pease, and Anderson in the *Astrophysical Journal*.

## Motorless or Wind Flight.

By Dr. S. BRODETSKY.

RECENT achievements in motorless flight, variously designated as *gliding*, *soaring*, and *sailing*, have attracted considerable attention, and much discussion has arisen as to the practical and military value of this new development, as well as to its scientific significance. While many authorities anticipate nothing more than the emergence of a new "sport," and ascribe little importance to motorless flights, others of a more imaginative turn of mind foresee great possibilities in this type of aerial navigation. The motorless flying machine has even been proclaimed as heralding the doom of the engine-driven aeroplane!

It is certainly premature to attempt a forecast of the future of flight in a glider. The art of gliding is, of course, older than that of flight in an engine-driven

machine: Lilienthal's experiments with gliders were made more than a generation ago, long before any aeroplane containing a motor rose into the air and executed a real flight. But Lilienthal, Pilcher, Chanute, Orville Wright, and others were not able to stay aloft in a glider more than a few minutes; whereas during the recent competitions in Germany, Martens remained in the air nearly three-quarters of an hour, and Hentzen stayed in the air two hours, and later three hours, performing evolutions of an intricate character. It is therefore clear that the art of gliding has entered upon a new phase, and the scientific problems involved merit careful discussion.

As already indicated, there is considerable diversity in the names given to the flights thus carried out

without the aid of a motor. All the three names mentioned above are really unsuitable. The term gliding is reminiscent of descent in an aeroplane, while the real interest of recent events has been in the fact that pilots were able to stay in the air very long without the help of a motor, and in fact performed climbing feats. The term soaring is less unsuitable, but it suggests climbing as the essential thing, whereas, in reality, horizontal flight in a glider is just as different from aeroplane flight as climbing in a glider. Finally, sailing is quite inappropriate as a description of the flight in question. Perhaps the term *wind-flight* is a really suitable name for flying without a motor, as distinguished from *engine-flight* in an aeroplane.

The wind is indeed the main instrument of motorless flight. Whether birds and other natural flyers do or do not derive energy from the air in some mysterious manner of which we have, as yet, no knowledge is a question that does not arise in the present connexion. The successes achieved have been the outcome of careful study of design and of movements in the air. In construction the gliders used look like aeroplanes without engines, and the determining factors in the flights were the various types of winds that blew while the machines were in the air.

It is clear that in a quiescent atmosphere the net result of any motion through the air in a motorless machine must be a diminution in the total energy, *i.e.* in the sum of the kinetic and potential energies. It follows that in the absence of wind, real flight, namely, flight in which the machine maintains its level for some considerable time, or rises still higher above the ground, is not possible without a source of energy like an engine. It is the presence of wind that puts in the hands of the pilot a source of energy, which can be used to neutralise the loss of energy involved in motion through the atmospheric resisting medium.

Although it should be obvious that the wind must be upwards or unsteady in order to supply this energy, it is necessary to say a few words about the case of a steady horizontal wind, since it has been claimed that "once the airman has left the ground he gets his energy from the *wind*, which may be level and steady." This is not correct, as can be proved quite simply. If we write down the equations of motion of a glider through the air under the action of gravity, we get three types of terms:

- (1) Accelerations in terms of the motion of the glider relative to the earth;
- (2) Gravity components;
- (3) Forces and couples due to air resistance, these being functions of the motion of the glider relative to the air.

It is useful to write the first terms, the accelerations, with reference to the motion of the glider relative to the air. When this is done for a steady wind, the resulting equations are exactly of the same form as if there were no wind at all, since the moving "air axes" move uniformly as seen from the "earth axes." This means that when there is a steady wind, we get the actual motion of the glider as seen from the earth, by adding the velocity of the wind to the motion of the glider in still air; in other words, to an observer travelling with the wind, the motion of

the glider would not reveal any effects that can be attributed to the steady wind.

In a horizontal steady wind, therefore, real flight is no more possible without an engine than in absolutely windless air. Any argument that leads to a contrary conclusion must have a fallacy somewhere, if we are to have any confidence in the principles upon which all our mechanics are based. It is true that a steady horizontal wind can be used as an aid in gliding. Thus, by pointing his machine into the wind the pilot can get off the ground with less initial speed than in still air. Further, when the machine is already in the air the pilot can, by pointing it with the wind, increase the horizontal distance travelled before reaching the ground again. But a steady horizontal wind cannot make the machine stay at the same level in the air for any length of time, or climb. For these purposes the wind must be upwards or variable.

If the wind is steady, but has an upward component, it helps in the attainment of real flight, which we can call wind-flight. Thus, if a glider is so constructed that in still air it performs a straight line glide with speed  $U$  at gliding angle  $\theta$  below the horizontal, then a steady wind of speed  $U$ , blowing at an angle  $\theta$  above the horizontal, will keep the glider suspended in the air indefinitely, if it points into the wind. And, more generally, if the steady wind has speed  $U'$  at an angle  $\theta'$  above the horizontal, where  $U' \sin \theta' = U \sin \theta$ , then the machine will fly horizontally with speed  $U \cos \theta - U' \cos \theta'$  relative to the earth, if it is given this speed initially against the wind. If  $U' \sin \theta'$  is greater than  $U \sin \theta$ , so that the vertical component of the wind is greater than the rate of vertical fall of the glider in still air, then the glider will climb with horizontal speed  $U \cos \theta - U' \cos \theta'$  and upward vertical speed  $U' \sin \theta' - U \sin \theta$ .

These results are simple and obvious. Given a steady wind with sufficient upward vertical component, a glider can perform real flights and make evolutions similar to those of ordinary aeroplane flight.

It is not necessary, however, to postulate steady upward wind. If the wind is variable, and this is, of course, usually the case, energy can be derived from the wind, even if it is horizontal, or downwards. This can be seen by a little analysis based on the ordinary equations of motion of the glider. Thus, suppose that the wind is in a straight line, but of varying speed. If we write the accelerations in these equations in terms of the motion relative to the air, we readily find that the motion of the glider relative to the air is the same as if the air were at rest, and a force per unit mass were given to the glider, in a direction opposite to that of the wind and proportional to the acceleration of the wind. If the wind rises steadily from zero to  $U'$  in time  $t$ , the motion of the glider is found by taking the air to be at rest and assuming that on each unit mass there acts, in addition to the weight, a force  $U'/gt$  in a direction opposite to the wind.

If, then, the machine is pointed into the rising wind, and the wind varies quickly enough, flying becomes possible. If the wind is being retarded, similar propulsive effect is obtained by pointing the machine with the wind. It follows that in a fairly sudden gust, which can be taken to consist of a quickly increasing



wind, followed by a quickly decreasing wind, the pilot can take advantage of both phases by pointing the machine into the rising wind, and with the falling wind. Quick manoeuvring is, of course, essential, as well as an intimate acquaintance with the movements that are always taking place in the air.

With more complicated variations in the wind, more complex results are obtained. It is now clear, however, that the future of wind-flight is associated with three main lines of study:

(1) The motions that are continually taking place in the atmosphere need to be studied, not only the meteorological wind phenomena as ordinarily understood, but particularly the detailed air motions, the "internal structure of the wind."

(2) Motorless flight presents problems of design that are different from those of ordinary aeroplanes. This is because the glider is a much lighter machine than the aeroplane. Stability is essential, but easy control is a *sine qua non*, since so much depends upon

taking as full advantage as possible of any temporary, and often unanticipated, motion in the air.

(3) The rigid dynamics of wind-flight is also an important factor in the progress of the art. Only in very exceptional circumstances can the motion of a glider be steady. Upward steady winds, or uniformly varying winds, are only of rare occurrence and brief duration, and in trying to perform real flight in an engineless machine the pilot must make use of any stray wind that comes to his aid. The motion in wind-flight must consequently be very variable. In this respect wind-flight must generally differ in essence from engine-flight. In the latter steady flight is the rule, in the former steady flight is bound to be a comparative rarity. The pilot must therefore learn from experience and from calculation to know what to expect from his machine under different conditions. The dynamics of wind-flight should be a fruitful subject of study both for the aviator and the mathematician.

### The Influence of the late W. H. R. Rivers on the Development of Psychology in Great Britain.<sup>1</sup>

By CHARLES S. MYERS, C.B.E., M.A., M.D., Sc.D., F.R.S.

A MOURNFUL gloom has been cast over the proceedings of our newly born Section. Since its inauguration twelve months ago this Section, as, indeed, psychology in general, has suffered an irreparable loss through the sudden death, on June 4 last, of him who was to have presided here to-day. When, only a few weeks ago, it fell to me, as one of his first pupils, to occupy Rivers's place, I could think of little else than of him to whom I have owed so much in nearly thirty years of intimate friendship and invaluable advice; and I felt that it would be impossible for me then to prepare a presidential address to this Section on any other subject than on his life's work in psychology.

William Halse Rivers Rivers was born on March 12, 1864, at Luton, near Chatham, the eldest son of the Rev. H. F. Rivers, vicar of St. Faith's, Maidstone, and of Elizabeth, his wife, *née* Hunt. Many of his father's family had been officers in the Navy—a fact responsible, doubtless, for Rivers's love of sea voyages. The father of his paternal grandfather, Lieutenant W. T. Rivers, R.N., was that brave Lieutenant William Rivers, R.N., who, as a midshipman in the *Victory* at Trafalgar, was severely wounded in the mouth and had his left leg shot away at the very beginning of the action, in defence of Nelson or in trying to avenge the latter's mortal wound. So at least runs the family tradition; also according to which Nelson's last words to his surgeon were: "Take care of young Rivers." A maternal uncle of Rivers was Dr. James Hunt, who in 1863 founded and was the first President of the Anthropological Society, a precursor of the Royal Anthropological Institute, and from 1863 to 1866 at the meetings of this Association strove to obtain that recognition for anthropology as a distinct Subsection or Section which was successfully won for psychology by his nephew, who presided over us at the Bourne-

mouth meeting in 1919, when we were merely a Sub-section of Physiology.

Our "young Rivers" gave his first lecture at the age of twelve, at a debating society of his father's pupils. Its subject was "Monkeys." He was educated first at a preparatory school at Brighton, and from 1877 to 1880 at Tonbridge School. Thence he had hoped to proceed to Cambridge; but a severe attack of enteric fever compelled him to take a year's rest, and thus prevented him from competing for an entrance scholarship at that University. He matriculated instead in the University of London, and entered St. Bartholomew's Hospital in 1882, sharing the intention of one of his father's pupils of becoming an Army doctor. This idea, however, he soon relinquished; but, like his desire to go to Cambridge, it was to be realised later in life.<sup>2</sup>

When he took his degree of Bachelor of Medicine in 1886 he was accounted the youngest Bachelor ever known at his hospital. Two years later he graduated as Doctor of Medicine, and he spent these two and the two following years in resident appointments at Chichester (1888) and at St. Bartholomew's (1889) hospitals, in a brief period of private medical practice (1890), and in travelling as ship's surgeon to America and Japan (1887), the first of numerous subsequent voyages.

In 1892 he spent the spring and early summer at Jena, attending the lectures of Eucken, Ziehen, Binswanger, and others. In a diary kept by him during this visit to Germany the following sentence occurs: "I have during the last few weeks come to the conclusion that I should go in for insanity when I return to England and work as much as possible at psychology." Accordingly, in the same year he became clinical assistant at the Bethlem Royal Hospital, and in 1893 he assisted G. H. Savage in his lectures on mental

<sup>1</sup> From the presidential address delivered to Section J (Psychology) of the British Association at Hull on Sept. 11.

<sup>2</sup> For many of the above details of Rivers's early life and antecedents I am indebted to his sister, Miss K. E. Rivers.

diseases at Guy's Hospital, laying special stress on their psychological aspect. Meanwhile, at Cambridge, Michael Foster was seeking some one who would give instruction there in the physiology of the sense organs, McKendrick having, as examiner in physiology, recently complained of the inadequate training of the Cambridge students in this branch of the subject. Foster's choice fell on Rivers, and in 1893 he invited him to the University for this purpose. Rivers went to Germany for a short period of study under Professor Kräpelin, then of Heidelberg, whose brilliant analysis of the work crude and careful investigations into the effects of drugs on bodily and mental work had aroused his intense interest. At Cambridge he set himself to plan one of the earliest systematic practical courses in experimental psychology in the world, certainly the first in this country. In 1897 he was officially recognised by the University, being elected to the newly established lectureship in physiological and experimental psychology. But the welcome and encouragement he received from cognate branches of study at Cambridge could scarcely be called embarrassing. Even to-day practical work is not deemed essential for Cambridge honours candidates in elementary psychology; psychology is not admitted among the subjects of the Natural Sciences Tripos; and no provision is made for teaching the subject at Cambridge to medical students. Rivers first turned his attention principally to the study of colour vision and visual space perception. Between 1893 and 1901 he published experimental papers "On Binocular Colour-mixture" (*Proc. Camb. Philosoph. Soc.*, vol. viii., pp. 273-77), on "The Photometry of Coloured Papers" (*Jour. of Physiol.*, vol. xxii., pp. 137-45), and "On Erythropsia" (*Trans. Ophthal. Soc., London*, vol. xxi., pp. 296-305), and until 1908 he was immersed in the task of mastering the entire literature of past experimental work on vision, the outcome of which was published in 1900 as an article in the second volume of the important "Text-book of Physiology," edited by Sir Edward Sharpey Schafer. This exhaustive article of 123 pages on vision by Rivers is still regarded as the most accurate and careful account of the whole subject in the English language.

In 1896 Rivers published an important paper "On the Apparent Size of Objects" (*Mind*, N.S., vol. v., pp. 71-80), in which he described his investigations into the effects of atropin and eserine on the size of seen objects. He distinguished two kinds of micropsia which had hitherto been confused—micropsia at the fixation-point due to irradiation, and micropsia beyond the fixation-point, which is of special psychological importance. Rivers came to the interesting conclusion that the mere effort to carry out a movement of accommodation may produce the same micropsia as when that effort is actually followed by movement. In other words, an illusion of size may be dependent solely on central factors. His later work, in conjunction with Prof. Dawes Hicks, on "The Illusion of Compared Horizontal and Vertical Lines," which was published in 1908 (*Brit. Jour. of Psychol.*, vol. ii., pp. 241-60), led him to trace this illusion to origins still less motor in nature. Here horizontal and vertical lines were compared under tachistoscopic and under prolonged exposure. The amount of the illusion was

found to be approximately the same for tachistoscopic as for prolonged exposure of the lines, but in the former the judgment was more definite and less hesitating—in other words, more naïve, more purely sensory, more "physiological"—than in prolonged exposure. Although this result is not inconsistent with the view that visual space perception depends for its genesis on eye movement, it compels us to admit that visual space perception, once acquired, can occur in the absence of eye movement; or, in more general language, that changes in consciousness, originally arising in connexion with muscular activity, may occur later in the absence of that activity. The provision of experimental evidence in favour of so fundamental and wide-reaching a view is obviously of the greatest importance.

In 1898, in which year he was given the degree of Hon. M.A. at Cambridge, Rivers took a fresh path in his varied career by accepting Dr. A. C. Haddon's invitation to join the Cambridge Anthropological Expedition to the Torres Straits. This was the first expedition in which systematic work was carried out in the ethnological application of the methods and apparatus of experimental psychology. His former pupils, Prof. W. McDougall and I, assisted Rivers in this new field. Rivers interested himself especially in investigating the vision of the natives—their visual acuity, their colour vision, their colour nomenclature, and their susceptibility to certain visual geometric illusions. He continued to carry out psychological work of the same comparative ethnological character after his return from the Torres Straits in Scotland (where he and I sought comparative data), during a visit to Egypt in the winter of 1900, and from 1901-2 in his expedition to the Todas of Southern India. His psychological investigations among the Torres Straits islanders, Egyptians and Todas (Reports of the Cambridge Anthropol. Exped. to Torres Straits, vol. ii., Pt. I., pp. 1-132; *Jour. of Anthropol. Inst.*, vol. xxxi., pp. 229-47; *Brit. Jour. of Psychol.*, vol. i., pp. 321-96) will ever stand as models of precise, methodical observations in the field of ethnological psychology. Nowhere does he disclose more clearly the admirably scientific bent of his mind—his insistence on scientific procedure, his delight in scientific analysis, and his facility in adapting scientific methods to novel experimental conditions. He reached the conclusion that no substantial difference exists between the visual acuity of civilised and uncivilised peoples, and that the latter show a very definite diminution in sensibility to blue, which, as he suggested, is perhaps attributable to the higher macular pigmentation among coloured peoples. He observed a generally defective nomenclature for blue, green, and brown among primitive peoples, both white and coloured, and large differences in the frequency of colour-blindness among the different uncivilised peoples whom he examined. In his work on visual illusions he found that the vertical-horizontal illusion was more marked, while the Müller-Lyer illusion was less marked, among uncivilised than among civilised communities; and he concluded that the former illusion was therefore dependent rather on physiological, the latter rather on psychological factors, the former being counteracted, the latter being favoured, by previous experience, e.g. of drawing lines or of apprehending complex figures as wholes.

In 1903, the year after his return from the Todas, and the year of his election to a Fellowship at St. John's College, Rivers began an investigation, continued for five years, with Dr. Henry Head; in which the latter, certain sensory nerves of whose arm had been experimentally divided, acted as subject, and Rivers acted as experimenter, applying various stimuli to the arm and recording the phenomena of returning cutaneous sensibility. The exact interpretation of this "Human Experiment in Nerve Division," published at length in 1908 (*Brain*, vol. xxxi., pp. 323-450), has been disputed by subsequent workers, whose divergent results, however, are at least partly due to their employment of different methods of procedure. Head's experiment has never been identically repeated, and until this has been done we are probably safe in trusting to the results reached by the imaginative genius and the cautious critical insight of this rare combination of investigators.

While working upon Head's arm, Rivers's indomitable activity led him to simultaneous occupation in other fields. In 1904 he assisted Prof. James Ward to found and to edit the *British Journal of Psychology*, and in that year he also received an invitation to deliver the Croonian Lectures in 1906 at the Royal College of Physicians, of which in 1899 he had been elected a Fellow. The study of drug effects had long interested him. So, reverting to the work he had done under Kräpelin many years previously, he chose as his subject for the Croonian Lectures, "The Influence of Alcohol and other Drugs on Fatigue" (Arnold, 1908). But although he utilised Kräpelin's ergograph and many of Kräpelin's methods, Rivers's *flair* for discovering previous "faulty methods of investigation" and his devotion to scientific methods and accuracy could not fail to advance the subject. Of no one may it be more truly said than of him,—*nihil tetigit quod non ornavit*. He felt instinctively that many of the supposed effects of alcohol were really due to the suggestion, interest, excitement or sensory stimulation accompanying the taking of the drug. Accordingly he disguised the drug, and prepared a control mixture which was indistinguishable from it. On certain days the drug mixture was taken, on other days the control mixture was taken, the subject never knowing which he was drinking. He found that the sudden cessation of all tea and coffee necessary for the study of the effects of caffeine induced a loss of energy, and that other mental disturbance might occur through giving up all forms of alcoholic drink. Therefore most of his experiments were carried out more than twelve months after the taking of these drinks had been discontinued. Instead of recording a single ergogram Rivers took several sets of ergograms each day, each set consisting usually of six ergograms taken at intervals of two minutes, and separated from the next set by an interval of thirty or sixty minutes. He arranged that the drug mixture or the control mixture should be taken after obtaining the first set of ergograms, which served as a standard wherewith subsequent sets on the same day might be compared. He worked with Mr. Webber on alcohol and caffeine, and was followed by the similar work of Dr. P. C. V. Jones in 1908 on strychnine, and of Dr. J. G. Slade in 1909 on Liebig extract.

With these vast improvements in method Rivers failed to confirm the conclusions of nearly all earlier

investigators on the effects of from 5 to 20 c.c. of absolute alcohol on muscular work. His results with these doses, alike for muscular and mental work, were mainly negative, and indeed with larger doses (40 c.c.) were variable and inconclusive; although an equivalent quantity of whisky gave an immediate increase of muscular work—a result which strongly suggests the influence of sensory stimulation rather than the direct effect of the drug on the central nervous system or on the muscular tissues. Rivers concluded that alcohol may in some conditions favourably act on muscular work by increasing pleasurable emotion and by dulling sensations of fatigue, but that probably its most important effect is to depress higher control, thus tending to increase muscular and to diminish mental efficiency.

From the concluding passages of these Croonian Lectures the following sentences may be aptly cited: "The branch of psychology in which I am chiefly interested is that to which the name of individual psychology is usually given. It is that branch of psychology which deals with the differences in the mental constitutions of different peoples, and by an extension of the term to the differences which characterise the members of different races. . . . These experiments leave little doubt that variations in the actions of drugs on different persons may have their basis in deep-seated physiological variations, and I believe that the study of these variations of susceptibility may do more than perhaps any other line of work to enable us to understand the nature of temperament and the relation between the mental and physical characters which form its two aspects." Throughout his life Rivers was steadfast to this biological standpoint, correlating the psychological with the physiological, and hoping to discover different mental levels corresponding to different neural levels.

Now we approach the last phase of Rivers's psychological work, the outcome of his war experiences. In 1907 he had given up his University teaching in experimental psychology; for six years before the war he had published nothing of psychological or physiological interest. This was a period in which Rivers devoted himself wholly to the ethnology and sociology of primitive peoples. The outbreak of war found him for the second time visiting Melanesia for ethnological field work. Failing at first to get war work on his return to England, Rivers set himself to prepare the Fitzpatrick Lectures on "Medicine, Magic and Religion," which he had been invited to deliver to the Royal College of Physicians of London in 1915 and 1916. In 1915 his psychological and ethnological researches were recognised by the award to him of a Royal Medal by the Royal Society, of which he had been elected a Fellow in 1908. In July 1915 he went as medical officer to the Maghull War Hospital, near Liverpool, and in 1916 to the Craiglockhart War Hospital, Edinburgh, receiving a commission in the R.A.M.C. In these hospitals he began the work on the psychoneuroses that led him to his studies of the unconscious and of dreams, which resulted in his well-known book, "Instinct and the Unconscious," and in a practically completed volume on "Conflict and Dream," which is to be published posthumously. From 1917 he acted as consulting psychologist to the

Royal Air Force, being attached to the Central Hospital at Hampstead.

This period marks not merely a new phase in Rivers's work, but is also characterised by a distinct change in his personality and writings. In entering the Army and in investigating the psychoneuroses he was fulfilling the desires of his youth. Whether through the realisation of such long-discarded or suppressed wishes, or through other causes, e.g. the gratified desire of an opportunity for more sympathetic insight into the mental life of his fellows, he became another and a far happier man. Diffidence gave place to confidence, hesitation to certainty, reticence to outspokenness, a somewhat laboured literary style to one remarkable for its ease and charm. More than forty publications can be traced to these years, between 1916 and the date of his death. It was a period in which his genius was released from its former shackles, in which intuition was less controlled by intellectual doubt, in which inspiration brought with it the usual accompaniment of emotional conviction—even an occasional impatience with those who failed to accept his point of view. But his honest, generous character remained unchanged to the last. Ever willing to devote himself unsparingly to a cause he believed right, or to give of his best to help a fellow-being in mental distress, he worked with an indomitable self-denying energy, won the gratitude and affection of numberless nerve-shattered soldier-patients, whom he treated with unsurpassed judgment and success, and attracted all kinds of people to this new aspect of psychology. Painters, poets, authors, artisans, all came to recognise the value of his work, to seek, to win, and to appreciate his sympathy and his friendship. It was characteristic of his thoroughness that while attached to the Royal Air Force he took numerous flights, looping the loop and performing other trying evolutions in the air, so that he might gain adequate experience of flying and be able to treat his patients and to test candidates satisfactorily. He had the courage to defend much of Freud's new teaching at a time when it was carelessly condemned *in toto* by those in authority who were too ignorant or too incompetent to form any just opinion of its undoubted merits and undoubted defects. He was prepared to admit the importance of the conflict of social factors with the sexual instincts in certain psychoneuroses of civil life, but in the psychoneuroses of warfare and of occupations like mining he believed that the conflicting instincts were not sexual, but were the danger instincts, related to the instinct of self-preservation.

Thus in the best sense of the term Rivers became a man of the world and no longer a man of the laboratory and of the study. He found time to serve on the Medical Research Council's Air Medical Investigation Committee, on its Mental Disorders Committee, on its Miners' Nystagmus Committee, and on the Psychological Committee of its Industrial Fatigue Research Board. He served on a committee, of ecclesiastical complexion, appointed to inquire into the new psychotherapy, and he had many close friends among the missionaries, to whom he gave and from whom he received assistance in the social and ethnological side of their work.

In 1919, in which year he received honorary degrees from the Universities of St. Andrews and Manchester,

he returned to Cambridge as Prælector in Natural Sciences at St. John's College, and began immediately to exercise a wonderful influence over the younger members of the University by his fascinating lectures, his "Sunday evenings," and above all by his ever-ready interest and sympathy. As he himself wrote, after the war work "which brought me into contact with the real problems of life . . . I felt that it was impossible for me to return to my life of detachment." And when a few months before his death he was invited by the Labour Party to a still more public sphere of work, namely, to become a Parliamentary candidate representing the University of London, once again he gave himself unsparingly. He wrote at the time: "To one whose life has been passed in scientific research and education the prospect of entering practical politics can be no light matter. But the times are so ominous, the outlook both for our own country and the world so black, that if others think I can be of service in political life I cannot refuse." On several occasions subsequently he addressed interested London audiences, consisting largely of his supporters, on the relations between psychology and politics. It was one of these very lectures—on the herd instinct—at which it happened that I took the chair, which was to have formed the basis of his Presidential Address to you here to-day.

Rivers's views on the so-called herd instinct were the natural outcome of those which he had put forward during the preceding five years and collected together in his "Instinct and the Unconscious." His aim in writing this book was, as he says, "to provide a biological theory for the psychoneuroses," to view the psychological from the physiological standpoint. He maintained that an exact correspondence holds between the inhibition of the physiologist and the repression of the psychologist. He regarded mental disorders as mainly dependent on the coming to the surface of older activities which had been previously controlled or suppressed by the later products of evolution. Here Rivers went beyond adopting Hughlings Jackson's celebrated explanation of the phenomena of nervous diseases as arising largely from the release of lower-level activities from higher-level controls. He further supposed that these lower-level activities represent earlier racial activities held more or less in abeyance by activities later acquired. This conception he derived from his work with Henry Head on cutaneous sensibility. Rivers could see but "two chief possibilities" of interpreting the phenomena disclosed in the study of Head's arm. Either epicritic sensibility is protopathic sensibility in greater perfection, or else protopathic sensibility and epicritic sensibility represent two distinct stages in the development of the nervous system. Failing to see any other explanation, he adopted the second of these alternatives. He supposed that at some period of evolution, when epicritic sensibility, with its generally surface distribution, its high degree of discrimination, and its power of accurate localisation, made its appearance, the previously existing protopathic sensibility, with its punctate distribution, its "all-or-nothing" character, and its broad radiating localisation, became in part inhibited or "suppressed," in part blended or "fused" with the newly acquired sensibility so as to form a useful product. He supposed that the suppressed portion

persisted in a condition of unconscious existence, and he emphasised the biological importance of suppression. He considered at first that the protopathic sensibility "has all the characters we associate with instinct," whereas the later epicritic sensibility has the characters of intelligence or reason. So he came to hold that instinct "led the animal kingdom a certain distance in the line of progress," whereupon "a new development began on different lines," "starting a new path, developing a new mechanism which utilised such portions of the old as suited its purpose."

*Evolutio per saltus* was thus the keynote of Rivers's views on mental development. Just as the experience of the caterpillar or tadpole is for the most part suppressed in the experience of the butterfly or frog, so instinctive reactions tend to be suppressed in intelligent experience whenever the immediate and unmodifiable nature of one becomes incompatible with the diametrically opposite characters of the other. Just as parts of the protopathic fuse with the later acquired epicritic sensibility, so parts of our early experience, of which other parts are suppressed, fuse with later experience in affecting adult character. "Experience," he explained, "becomes unconscious because instinct and intelligence run on different lines and are in many respects incompatible with one another."

From his point of view Rivers was naturally led, wherever possible, to interpret abnormal mental conditions in terms of regression to more primitive, hitherto suppressed activities. He held that the hysterias are essentially "substitution neuroses," connected with and modified by the gregarious instincts, and are primarily due to a regression to the primitive instinctive danger reaction of immobility, greatly modified by suggestion. So, too, he held that the anxiety neuroses, which are for him essentially "repression neuroses," also show regression, though less complete, in the strength and frequency of emotional reaction, in the failure during states of phantasy to appreciate reality, in the reversion to the nightmares, and especially the terrifying animal dreams, characteristic of childhood, in the occurrence of compulsory acts, in the desire for solitude, etc. He criticised Freud's conception of the censorship, substituting in place of that anthropomorphically-coloured sociological parallel the physiological and non-teleological conception of regression.

We are now in a position to examine Rivers's treatment of the gregarious behaviour of animal and human life, on which he was still engaged at the time of his death. In the gregarious instinct he recognised a cognitive aspect which he termed "intuition," an affective aspect which he termed "sympathy," and a motor aspect which he termed "mimesis." He used "mimesis" for the process of imitation so far as it was unwitting; "sympathy" he regarded as always unwitting. "Intuition" he defined as the process whereby one person is unwittingly influenced by another's cognitive activity. But I feel sure that the term "unwittingly" is not to be considered here as equivalent to "telepathically." All that Rivers meant was that the person is influenced by certain stimuli without appreciating their nature and meaning. He preferred to employ the term "suggestion" as covering all the processes by which one mind acts on or is acted on by another unwittingly. He supposed that in the

course of mental evolution epicritic characters displaced the early protopathic characters of instinctive behaviour owing to the incidence of gregarious life, especially among insects, and owing to the appearance and development of intelligence, especially in man. The suggestion inherent in gregarious behaviour implies some gradation of mental and bodily activity—an instinctive and unwitting discrimination distinct from the witting discrimination of intelligence.

Were he here to-day Rivers would have carried this conception of the evolution of gregarious life still further by distinguishing between the more lowly leaderless herd and the herd which has acquired a definite leader. He would have traced the development of the new affect of submission and of the new behaviour of obedience to the leader, and he would doubtless have accredited the leader with the higher affects of superiority and felt prestige, with the higher cognition that comes of intuitive foresight, and with the higher behaviour of intuitive adaptation, initiative, and command. I expect, too, that he would have sketched the development of still later forms of social activity, complicated by the interaction and combination of intellectual and instinctive processes—the witting deliberations and decisions on the part of the leader, and the intellectual understanding of the reasons for their confidence in him and for their appropriate behaviour on the part of those who are led.

But it would be idle further to speculate on the ideas of which we have been robbed by Rivers's untimely death. Let us rather console ourselves with the vast amount of valuable and suggestive material which he has left behind and with the stimulating memories of one who, despite the fact that his health was never robust, devoted himself unsparingly to scientific work and to the claims of any deserving human beings or of any deserving humane cause that were made upon him. There are, no doubt, some who believe that Rivers's earlier experimental psychological work—on vision, on the effects of drugs, and on cutaneous sensibility—is likely to be more lasting than his later speculations on the nature of instinct, the unconscious, dreams, and the psychoneuroses. No one can doubt the scientific permanence of his investigations in the laboratory or in the field; they are a standing monument of thoroughness and accuracy combined with criticism and genius. But even those who hesitate to suppose that at some definite period in mental evolution intelligence suddenly made its appearance and was grafted on to instinct, or that epicritic sensibility was suddenly added to a mental life which had before enjoyed only protopathic sensibility—even those who may not see eye to eye with Rivers on these and other fundamental views on which much of his later work rested, will be foremost in recognising the extraordinary stimulating, suggestive, and fruitful character of all that he poured forth with such astounding speed and profusion during the closing years of his life. Above all, we mourn a teacher who was not merely a man of science devoted to abstract problems, but who realised the value of and took a keen delight in applying the knowledge gained in his special subject to more real and living problems of a more concrete, practical, everyday character. Rivers's careful methods of investigating

cutaneous sensibility and the *rationale* of his successful treatment of the psychoneuroses were directly due to his psychological training. So, too, his epoch-making discoveries and his views in the field of anthropology on the spread and conflict of cultures were largely due to the application of that training. Shortly before his death he was developing, as a committee member of the Industrial Fatigue Research Board, an intense interest in that youngest application of psychology, namely, to the improvement of human conditions in industrial and commercial work by the methods of experimental psychology applied to fatigue study, motion study, and vocational selection.

Unhappily, men of such wide sympathies and understanding as Rivers, combined with a devotion to scientific work, are rare. He himself recognised that "specialisation has . . . in recent years reached such a pitch that it has become a serious evil. There is even a tendency," he rightly said, "to regard with suspicion one who betrays the possession of knowledge or attainments outside a narrow circle of interests" (*Brit. Jour. of Psychol.*, vol. x., p. 184). Let his life, his wisdom, his wide interests, sympathies and attainments, and the generosity and honesty of his character, be an example to us in the common object of our meeting this week—the advancement of science.

### Obituary.

PROF. F. D. BROWN.

WE regret to announce the death, on August 2, at Remuera, New Zealand, of emeritus professor Frederick Douglas Brown, at the age of seventy years. Prof. Brown began the study of chemistry in 1870, under Dr. Matthiessen, at St. Bartholomew's Hospital. On the death of Dr. Matthiessen, he continued his studies at the Royal College of Science, South Kensington and afterwards in Leipzig. On his return to England about 1876, he began research work at the London Institution with Prof. Armstrong, whom he had known at St. Bartholomew's. He then spent some time in Prof. Guthrie's laboratory and afterwards in the University Laboratory, Oxford. During this period, he was concerned in the teaching of chemistry at Cheltenham and Clifton Colleges and he also supervised the construction of the chemical laboratories in University College, Nottingham.

In 1883, Brown was appointed professor of chemistry and physics in Auckland University College, a post he held until 1914, when he came to England; but he was so upset by the conditions of the war, especially the bombing, that he gave up his intention of settling here and, in 1918, returned to the quiet of New Zealand. He did the greatest possible service to the cause of scientific education in New Zealand, where he was generally held in high esteem.

A man of original and independent, aristocratic mind but entirely unobtrusive though charming manner, firm and clear in his convictions and with a specially developed sense of accuracy and thoroughness, Brown's scientific work was of a classic character, though through force of circumstances it could not be large in amount: however, he not only made the best of the material that was at his disposal in Auckland but was also successful in inspiring those who studied under him with his own high conceptions of scientific duty. The work by which he is best known probably is that relating to fractional distillation, a subject on which he was an authority in early days; he also paid much attention to the cyanide process of extracting gold.

PROF. F. T. TROUTON, F.R.S.

At Trinity College, Dublin, in the 'eighties of last century, there assembled under Prof. FitzGerald a small band of enthusiastic physicists of great ability and originality, brought together by a common admira-

tion and affection for their chief. Names which will always be connected with this brilliant school of physics are Joly, Preston, and Trouton. FitzGerald himself did not live to be fifty, Preston died in his fortieth year, and now, to the great grief of all those who ever knew him, Trouton has left us at the age of fifty-eight, after having been kept by illness for the past ten years from the researches he loved.

Trouton was born in Dublin in November 1863, the son of a family well known in that city. As a student at Trinity College he gave early evidence of that versatility and quickness of grasp which characterised his scientific career. He studied both engineering and the physical sciences, and before graduating had already on one hand taken a leading part in surveying for a railway, and on the other enunciated that connexion between latent heat and molecular weight which is known as Trouton's Law.<sup>1</sup> He closed a brilliant undergraduate career by taking degrees in engineering and science at the same time, being awarded the coveted Large Gold Medal, rarely bestowed for science. He at once became assistant to the professor of physics at Trinity College, and until FitzGerald's death in 1901 he remained the cherished colleague and intimate friend of that great man. They carried out in collaboration many experiments, including an important series confirming, to a high degree of accuracy, Ohm's law for electrolytes. Trouton never spoke of FitzGerald without emotion characteristic of his generous nature.

The Dublin school was immediately struck with the importance of Hertz's experiments on electromagnetic waves, which were published in 1887 and 1888, and Trouton was one of the first to repeat them and to carry out original work on the subject. He settled the long-disputed question as to the relation between the direction of the vibration in the wave-front of an electromagnetic (light) wave and the plane of polarisation, by showing that the electric vector is normal to, and the magnetic vector in, the plane of polarisation. He demonstrated many analogies with optical experiments by suitably increasing the size of the apparatus to correspond to the great wave-length of the Hertzian waves—thus a wall built of bricks of paraffin wax was used to replace the soap film of ordinary light experiments. Trouton's work did much to establish the common electromagnetic nature of ordinary light and of Hertzian waves.

<sup>1</sup> If  $M$  be the molecular weight,  $L$  the latent heat,  $T_1$  the absolute temperature, then  $ML/T_1$  is constant.

FitzGerald was deeply interested in the question of the possibility of detecting the earth's motion through the æther, and Trouton eagerly took up a suggestion to investigate the mechanical effect of charging a condenser moving in the plane of its plates through the æther. The experiment, which is well known to all students of relativity, gave a negative result. It was in 1902, just after this research, that Trouton was appointed to the Quain professorship of physics at University College, London. He had at the time been for some years a Fellow of the Royal Society. His first work here was to repeat, with Noble, the condenser experiment in an improved form. Later he devised another experiment, designed to detect the FitzGerald shrinkage, which consisted in comparing the electrical resistance of a wire when moving in and across the æther stream. This was carried out in collaboration with Mr. (now Prof.) A. O. Rankine, and led to a negative result. The results of these experiments are in accord with the theory of relativity, for which they offer important evidence.

Trouton carried out researches in a variety of directions, including some on the viscosity of solids, and others on the condensation of water vapour on different surfaces, the latter of which led to the discovery of an interesting analogy to the James Thomson portion of an isothermal. His last work was on the adsorption of dye-stuffs on sand at various concentrations, and gave results of an intriguing nature which cannot be described here. It was while engaged on these investigations in 1912 that Trouton was attacked by a severe illness. He recovered from a prolonged prostration sufficiently for it to be hoped that he would be able to attend the meeting of the British Association in Australia in 1914, and he was elected president of Section A for that meeting. He prepared his presidential address, but was unable to travel, as an early operation was advised. It was held to be partly successful, but he never walked again. When he resigned his pro-

fessorship at University College he received the title of emeritus professor.

The investigation of newly discovered or of neglected phenomena had a great fascination for Trouton; he was always breaking fresh ground, and had little inclination for working over subjects on which many investigations had been carried out—"pouring water on a drowned rat," as he characteristically expressed it. In daily life he was a man of great charm and sincerity; his wit, his buoyancy, and his whimsical and incisive phrases were a constant delight. He never lost an opportunity of helping a student or colleague, and his kindness was evident in all his actions, a kindness which had its roots in strength, and not weakness, of character. When in the prime of life he was struck down by a cruel and lingering illness he carried his cheerfulness to his couch, and would receive visitors with something like the old twinkle in his eye. Fate did not spare him; he lost two hopeful and beloved sons in the war, and saw all hope of recovery slowly pass from him. He died peacefully at his house at Downe on September 21, and, although his death was not unexpected, it brought to his friends a distress no less poignant for that.

E. N. DA C. A.

WE regret to see announcements of the following deaths:—Prof. Arthur Mayer, formerly director of the Botanic Garden at Marburg, at the age of seventy-two years; Dr. William Kellner, formerly chemist to the War Department, aged eighty-two; on September 25, Prof. J. P. Kuenen, of the University of Leyden, aged fifty-five; on September 27, Mr. C. Michie Smith, late director of the Kodaikanal and Madras Observatories; and on September 28, Major-General James Waterhouse, from 1866 to 1897 Assistant Surveyor-General in charge of photographic operations in the Surveyor-General's Office, Calcutta, at the age of eighty years.

### Current Topics and Events.

THE hundredth anniversary of the birth of Mendel was celebrated in Brünn on September 23 last. The Government of Czecho-Slovakia placed generous funds at the disposal of a local committee, which arranged the centenary celebrations with the liberality and efficiency that we have learnt to expect from the new Czecho-Slovakian state. Credit is especially due to the committee for having made the centenary an occasion for bringing together, for the first time since the war, geneticists of all lands, the visitors comprising representatives of America, Austria, Denmark, England, Finland, Germany, Holland, India, Japan, Jugoslavia, Norway, Poland, Sweden, and Switzerland. The official proceedings opened with a visit to the monastery in which Mendel had lived, and to the adjoining garden in which he made his experiments. Wreaths were laid before the monument of Mendel which was erected in 1910, and speeches were made by the chairman of the local Naturwissenschaftlicher Verein, by the official representative of the Government, by the Burgomeister, by Prof.

Erwin Baur (Berlin), Prof. Chodat (Geneva), Prof. Némec (Prague), Mr. S. Pease (Cambridge), and Prof. Iltis (Brünn). At the luncheon which followed, the principal speaker was Prof. Wettstein (Vienna), who emphasised particularly the international significance of the event. Prof. C. B. Davenport (Washington) replied, and the official proceedings terminated with a speech by Prof. Richard Hertwig (Munich). In the evening, a special performance was given at the opera, to which the guests were invited: it was the first occasion in Brünn on which the works of Czech and German composers had appeared on the same programme, a matter locally of much comment and great importance. The next day an expedition to recently discovered and very remarkable caves in the Moravian Karst was arranged. It is to be hoped that the success of this gathering will encourage others to organise congresses that are international and not merely inter-allied, in order that the friendships and intercourse which the war destroyed may be once more built up.

A KINDLY function was fulfilled at the London School of Tropical Medicine on Monday evening of last week, September 25, before a company of friends of the School and the family, when the first mint of the new medal instituted in memory of Sir Patrick Manson was presented to his widow. Major-General Sir William Leishman, who made the presentation, explained that the medal was the sub-issue of a project by friends of Sir Patrick Manson to present to the School a portrait of its illustrious originator. As the result of an appeal for this purpose, subscriptions in excess of the actual requirements quickly came in from many parts of the world, accompanied by numerous very cordial tributes of approval. The portrait had been presented, and when all expenses had been met there still remained a balance which the committee of subscribers thought would find its most happily inspired application in a medal commemorative of Sir Patrick Manson's unique position in the history of tropical medicine. In a graceful speech Sir William Leishman alluded to the many ways whereby, outside the laboratory, quite as effectively as within it, a wife can further her husband's work, and said that it was with a full appreciation of the circumstances from this point of view, and not as a mere compliment, that the committee desired to offer the first-minted medal to Lady Manson.

M. LE TROCQUER, Minister of Public Works, was present at tests on September 26, in connexion with the utilisation of tidal power at Aberwrach, near Brest. The scheme is to comprise a barrage 150 metres in length, which will permit of the storage in a tidal basin of from one to four million cubic metres of water, depending on the tidal range. Four turbines are to be installed, working both on the ebb and flow of the tide and capable of delivering 750-1200 h.p. These are coupled to alternators delivering current at 1500 volts. This station is to work in conjunction with a water-power station developing power from river-flow, and the latter is to be used to regularise the intermittent output from the tidal-power scheme. Should the results of this investigation prove satisfactory it is intended to develop a much larger scheme on the Rance, and, according to the *Times* of September 28, the minister expressed the opinion that this would enable electrical energy to be supplied to the whole of Western France.

WE learn from the *Chemical Age* that the chairman of the Allied Chemical and Dye Corporation of New York has offered, through the American Chemical Society, an annual prize of 25,000 dollars "to reward the chemist, residing in the United States, who in the opinion of a properly constituted jury has contributed most to the benefit of the science and of the world." In communicating the offer, the chairman of the Corporation writes: "Realising, as we do, the enormous influence which chemists working in all the fields of that science will have on the welfare of the world, we desire by this prize so to encourage the workers that even larger benefits should accrue than those which have already placed the world under such a debt of gratitude to the profession." Last week refer-

ence was made in our columns (p. 466) to numerous substantial gifts by industrial concerns in Germany to German universities to assist in the teaching of scientific subjects, particularly chemistry. Thus in both the United States and in Germany, commercial men and manufacturers are showing their appreciation of the value of what may be termed, research in pure science.

ACCORDING to *Science*, the American Medical Association has agreed to co-operate with the directors of the Gorgas Memorial Institute of Tropical and Preventive Medicine in establishing the institute, and a committee of the Association has issued an appeal for subscriptions. The committee is agreed that the most suitable memorial to Major-General William C. Gorgas would be such an institute, and considers that no more appropriate place than Panama City, where General Gorgas's great work in stemming tropical diseases was done, could have been selected. The Government of Panama has given the Santo Tomas Hospital, and also the land on which it is proposed to build the laboratories and departments for research, to constitute the memorial institute; Dr. R. P. Strong has been appointed scientific director. It is also intended that a Gorgas School of Sanitation shall be established in Tuscaloosa, Alabama, for training public health workers and sanitary engineers especially for work in the Southern States of America. An endowment of some 1,300,000*l.* will be necessary to carry out in full the proposed memorial.

PROF. SANTIAGO RAMÓN Y CAJAL has retired from the chair of histology and pathological anatomy in the University of Madrid. This distinguished man of science, who is a Foreign Member of the Royal Society, has been the recipient of numerous honours in Spain, including the Echegaray medal, presented to him in the Royal Academy of Sciences by the King of Spain. The Spanish Government has introduced a bill for the construction of a building for the Cajal Institute, constituted in 1920, which carries with it an appropriation of nearly 36,000*l.*, divided into four sums to be expended annually from 1922 to 1925 on the building designated as Cajal's Biological Institute; in addition, a grant of about 1700*l.* is to be provided for maintenance. The work of the institute will be directed by a board of trustees under the chairmanship of Cajal himself.

ABOUT a year ago the Chemical Society issued an appeal to its fellows to assist in the alleviation of distress among chemists and other scientific workers in Russia. Since then a sum of more than 210*l.* has been received, and about 170*l.* of it was devoted to the purchase of clothing, which has been distributed among men of science in Ekaterinburg, Moscow, and Petrograd. In addition, three cases containing clothing and books have been sent to the latter two cities. It is now known definitely that the packages have reached those for whom they were intended, so that the possibility of gifts going astray need no longer deter possible subscribers. There is every reason to fear that during the coming winter distress will be as acute as it was a year ago, and the Chemical



Society appeals to all British chemists to give assistance. Gifts of money, clothing, books, and recent chemical literature should be addressed to the Assistant Secretary, The Chemical Society, Burlington House, Piccadilly, W.1.

In his presidential address delivered before the Royal Anthropological Institute (vol. lii. part i.) the late Dr. Rivers laid special stress on the difficulties which impede research by the excessive cost of printing and book production, and the rise in rent and taxes for accommodation used by scientific societies. He pointed out how closely all the branches of anthropological work—physical, sociological, archaeological, psychological—are connected. Numerous societies, like the Royal Asiatic, African, and Japan societies, with the Hellenic and Roman societies and that specially devoted to folk-lore, should become more closely allied than is the case at present. The provision of a common building with adequate accommodation for a lecture room, library, and secretarial quarters would do much to reduce expenditure and promote efficiency. The leading society, the Royal Anthropological Institute, is most inadequately housed, while the Folk-lore Society has no headquarters of its own. It is quite time that an earnest effort was made to reorganise the work of these and similar societies. Individual jealousies and prejudices must be encountered, but the spirit of conciliation, reinforced by the difficulties of the present situation, should succeed in framing a scheme of co-operation.

In accordance with arrangements followed for many years past there is to be a series of meetings, generally

on alternate Mondays at 5 P.M., at the Meteorological Office, South Kensington, for the informal discussion of important contributions to meteorological literature, especially in foreign and Colonial journals. The meetings will commence on Monday, October 16, when, as customary at the first meeting, the discussion will be opened by Sir Napier Shaw. The subject is a paper by V. Bjerknes "On the dynamics of the circular vortex with application to the atmosphere and atmospheric vortex of wave motions."

THE third of the series of lectures, under the auspices of the Institute of Physics, on physics and the physicist in industry will be given by Mr. Clifford C. Paterson, who will take as his subject, "The Physicist in Electrical Engineering." The lecture will be delivered on Wednesday October 18 at 6 P.M. at the Institution of Electrical Engineers, Victoria Embankment, W.C.2.

ON the recommendation of the committee of management of *Science Abstracts*, the council of the Institution of Electrical Engineers has appointed Mr. W. R. Cooper to be editor of the publication in succession to the late Mr. L. H. Walter. Mr. Cooper was acting editor of *Science Abstracts* in the first year of its existence, 1898, and afterwards was editor from 1899 to 1901.

THE Home Secretary gives notice that summer time will cease this year at 3.0 A.M. (summer time) in the morning of Sunday, October 8, when clocks will be put back to 2 A.M. The shorter period of summer time prescribed by the Summer Time Act, 1922, does not operate this year.

### Our Astronomical Column.

OCTOBER METEOR SHOWERS.—The month of October is usually one of the best periods for observing meteors. The moon will interfere this year in the early part of the month, but during the last half, observations may be satisfactorily made. The chief shower generally visible falls in the third week of the month, and is directed from a radiant point at  $91^{\circ} + 15^{\circ}$  on the north-eastern borders of Orion. There is also a strong shower which supplies slow and often brilliant meteors at about the same time as the Orionids, but this radiant in the eastern region of Aries at  $42^{\circ} + 21^{\circ}$  appears to be visible for a long period, and is also seen in the months of November and December. The Taurids often form a conspicuous display towards the end of October, but they are generally more abundant in November than at any other time of the year. The latter shower yields meteors very similar to the Arietids, and fireballs are frequently intermingled with the smaller members of the stream. The chief radiant is at  $64^{\circ} + 22^{\circ}$ ; it is difficult to define the date of maximum, but it usually occurs between November 20 and 23.

The meteoric activity of October is not confined to a few systems, for a very large number, certainly several hundreds, may be recognised. They are, however, for the most part feeble, like the majority of the systems which are distributed over the firmament.

PARALLAXES OF 22 CEPHEIDS.—Dr. Harlow Shapley's estimates of the distances of the globular clusters rest largely on the assumed absolute magnitudes of B stars and Cepheid variables. It is very desirable to have as many independent determina-

tions as possible of the distances of the brighter Cepheids, in order to check their assumed absolute magnitudes. Dr. S. A. Mitchell has determined the trigonometrical parallaxes of 22 of them, and publishes the results in the *Observatory* for September. Perhaps the most doubtful point is the mean parallax of the comparison stars; they are of the 10th magnitude, assumed parallax  $0^{\circ}.005$ . The deduced absolute parallaxes for the Cepheids range from  $+0^{\circ}.046$  ( $\rho$  Cassiopeiae) to  $-0^{\circ}.018$  ( $\gamma$  Cygni). There are only 3 negative parallaxes. The mean parallax agrees very closely with the mean of the spectroscopic values; rejecting  $\rho$  Cassiopeiae, the mean difference, Mitchell minus spectroscopic, is only  $0^{\circ}.0003$ . It is concluded that the latter are very accurate.

NOVA T CORONAE (1866).—This Nova is exceptional in two ways. It is the only Nova that was a catalogued star before the outburst (BD  $+26^{\circ} 2765$ ), and it is much farther from the Galaxy than other Novae. Mr. K. Lundmark investigates its proper motion and parallax in Publ. Ast. Soc. Pacific, August 1922. The proper motion is given as  $0^{\circ}.012$  annually, towards position angle  $41^{\circ}$ ; from this the parallax is inferred to be  $0^{\circ}.0010$ , while the spectroscopic parallax is  $0^{\circ}.0014$ . Adopting  $0^{\circ}.0013$ , its present absolute magnitude is  $+0.2$ , while that at the outburst was  $-7.4$ , in good agreement with the maximum value for other Novae. The star is an M giant, and apparently is now in the same condition as before the outburst. If the above parallax is near the truth, the star is considerably more remote than Nova Persei (1901) or Nova Aquilae (1918).

## Research Items.

**THE STATUE OF SOPHOCLES IN THE LATERAN MUSEUM.**—The chief glory of the Lateran Museum is the great statue usually supposed to be that of the poet Sophocles. This identification is disputed by Mr. Theodore Reinach (*Journal of the Hellenic Society*, vol. xlii. Part 1), who, after a full discussion of the evidence, identifies it with the famous statue of Solon of Salamis, dating about 391 B.C., the work of the artist Kephisodotus, whose son and pupil seems to have been Praxiteles. This new work by a great master thus stands out as the herald of a new dawn of art, the real link between the divine Phidias and the divine Praxiteles.

**EXCAVATIONS AT THE SITE OF BETHSHEAN.**—The town of Bethshean, afterwards, for some unexplained reason, known as Scythopolis, lay between the Little Hermon and Gilboa ranges, on a plain about three miles west of the Jordan. Permission to excavate the site by the University Museum, Philadelphia, having been granted by the Archaeological Department of Palestine, the work was started in 1921 under the superintendence of Mr. C. S. Fisher. Fortunately no Mahomedan tombs or other buildings on the mound interfere with the work of excavation. The stratification shows a continuous occupation of the site from Arab, Byzantine, and Classical times down to the early Semitic period. The results of the excavations, so far as they have proceeded, are described in the March issue of the *Museum Journal*. The most important discovery made is that of a large basalt stele with an Egyptian inscription of Sety I. (1313-1292 B.C.). When the lowest stratum is reached it is hoped that much light will be thrown on early Semitic life and religion.

**BANTU THROWING-STONES AND BRASS.**—In the Report of the South African Museum for 1921, Dr. Péringuey discusses some large rounded stones, perforated in the manner of the Bush *Kwee*, and weighing about 18 lb. He does not think that they could have been used to weight digging-sticks or as rolling mill-stones. With them were some stones, also perforated, but rather flat, with a sharp edge. These, it is said, were carried on a stick by the Bantu, and used for throwing at the legs of bucks. This explains the use of some heavy brass rings found in Swaziland, and the question arises whether the brass was made in that country or was imported. The Chief Regent of Swaziland says that the former was the case, and adds: "The process of separating was by melting the minerals and certain chemicals known to our ancient blacksmiths and founders. In the making of brass and other metals, copper, lead, and zinc were used for the manufacture of bangles, etc., which were worn only by Royalties. The bangle in this form is known as *Itusi*; it is the form in which brass is kept, instead of making it into bars as the Europeans do." Specimens in the museum show that the Bantu had also a bronze industry, but the rarity of such objects is rather remarkable, and Dr. Péringuey suggests as the reason the very early supersession of bronze by iron in South Africa.

**PHYSICAL NATURE OF VERSE.**—A recent number of the *Wiener Medizinische Wochenschrift* reports a lecture at the University of Vienna by Prof. E. W. Scripture, of London and Hamburg, on recent researches in experimental phonetics. Speech is registered by physical means on a recording drum, and the resulting curves are analysed and measured under a microscope. One of the latest problems is

that of the physical nature of verse. Verse is shown to be a continuous vocal gesture. There are no syllables, no feet, no measures, no possibility of such notions as iambus or trochee. The entire system of metre as taught in modern prosody is held to be a fantastic construction that has not the slightest relation to verse as actually spoken. Any attempt to fit it to verse or fit verse to it results in such monstrosities as some of the present corrections to the text of Shakespeare, with apologies for the bad verse he is supposed to have written. Verse, from a physical point of view, is shown to be a flow of speech energy with regularly recurring regions of greater density. The total of this energy can be treated as if condensed at certain points—centroids or centres of gravity. These centroids recur at regular intervals and give the effect of beats. This regular recurrence of centroids constitutes the whole of the system of verse. Another topic presented was the recent work on registering speech in nervous diseases. Three diseases—epilepsy, disseminated sclerosis, and general paralysis—show specific peculiarities in the records. A diagnosis thus becomes an automatic thing; the speech is registered, the curves are analysed and measured, and the result appears of itself.

**THE SITE AND GROWTH OF LONDON.**—The relation of topography and underlying structure to the growth of London are traced in some detail by Mr. C. E. M. Bromehead in a paper in the *Geographical Journal* for August. After describing the extent of alluvial and river gravels and the course of the Thames tributaries in the area now covered by London, Mr. Bromehead points out that the narrowness of the river and the approach by gravel banks from either side marked the present site of London Bridge as the lowest ford. Around this, especially on the better situated northern bank, the original London grew. The essentials of the site, in addition to the ford, were twin hills capped by water-bearing gravels separated by the valley of the Wall Brook, bounded on the west by the Fleet and on the east by the low ground of the Thames marshes. To the north was the forest area of the London clay, but the river gravels were comparatively bare. The early Roman camp, which was the earliest historic London, was on the east hill; on the west hill the brick earth was worked until the city grew over it. Mr. Bromehead traces the growth of London through Saxon times and up to the Great Fire in 1666. After that event London rapidly expanded. The limit of the gravels for a long time set a limit to building operations. Wells sunk through the gravel, seldom more than 25 ft. in thickness, were sure to tap water, but it was not realised till recent times that better supplies could be obtained beneath the clay at depths of 150 ft. and more. It was for this reason that the areas of bare London clay remained unoccupied until the advent of steam pumping and iron water mains. Once these difficulties of water supply were overcome, the clay areas were rapidly built over and outlying hamlets became linked up with London.

**MEDIAN PROLIFICATION OF FLOWERS OF HEMEROCALLIS.**—We learn from Dr. J. C. Costerus, of Hilversum, Holland, that he has observed numerous central floral proliferations in *Hemerocallis fulva* in gardens at Hilversum, in the botanic gardens at Amsterdam and Utrecht, and also at Twickenham in this country, during the past summer. Apparently the proliferation resembled closely a "doubled" flower. Median proliferation of flowers of *Hemerocallis*, although apparently rare, has been noted on

several occasions and is referred to in "Vegetable Teratology," by the late Dr. Maxwell T. Masters. While it is difficult to suggest a reason for the phenomenon with any degree of certainty, it is probable that the condition may have been more prevalent than usual this year owing to the prolonged drought of 1921 and the early months of 1922, placing a check upon normal development, followed by a rush of vigorous growth brought about by the wet summer months. A check to growth followed by a sudden change to first-rate growing conditions often brings about fasciation, and the median proliferation of flowers of *Hemerocallis* may be regarded in a rather similar light to fasciation.

**LIFE-HISTORY OF THE NEUROPTEROUS INSECT ITHONE.**—In the Bulletin of Entomological Research, vol. xiii. pt. 2, August 1922, Dr. R. J. Tillyard gives a very detailed account of the biology of *Ithone fusca*, an Australian moth-lacewing. It appears that the complete life-history occupies two years, and the eggs are laid in soft or sandy ground, each being rolled separately in the sand, which adheres to its sticky surface, forming a protective covering. The larvæ are very different from those of other Neuroptera Plannipennia, being curved and more or less scarabeiform in their general features. There appear to be at least five instars instead of the usual three or four present in other members of the sub-order. The cocoon is spun from the anal end of the body, and the pupa is armed with large jaws for cutting a way out for the emergence of the imago. The larval food appears to be mainly scarabæid grubs, and Dr. Tillyard is so impressed with the value of *Ithone* in reducing the numbers of these organisms, that he has decided to test its capabilities as an aid to agriculture in New Zealand. Some 7000 fertile eggs of *Ithone fusca* have been introduced, and it remains to be seen whether the larvæ will succeed in establishing themselves under the new conditions, and serve as a help towards controlling the "grass-grubs." The latter are serious pests with but few natural enemies in New Zealand.

**THE MAGNIFICENT SPIDER (*Dicrostichus magnificus*, Rainbow).**—In the Proceedings of the Royal Society of Queensland (vol. xxxiii. 1921, pp. 91-98, pls. 7 and 8) Mr. H. A. Longman gives an interesting account of this very large and handsome spider. It appears that the creature constructs egg-cocoons of a more or less elongate-fusiform shape, each being suspended by a pedicel attached to a bush. Their total length measures from three to four inches with a maximum diameter of about one inch. The cocoon is double, one cocoon lying within the other, and between them is a loose packing of delicate silk. Within the inner cocoon are the eggs, which number more than 600, and, taking five cocoons as an average, each spider lays about 3000 eggs. After hatching, the young spiders climb up the surrounding leaves and spin fine threads. On the latter they are floated, or ballooned, through the air to start life on their own account. The author gives a detailed account of how this remarkable cocoon is spun by the parent, which, although skilful in this art, had neither the capacity nor inclination to mend a rent in it when it was torn by a cricket-like insect. The spider constructs no web for ensnaring prey, but shortly after sunset it hangs suspended from a horizontal line near its cocoons. From this slender bridge it spins a short filament which hangs downwards and terminates in a globule of viscid matter a little larger than the head of an ordinary pin. The filament is held out by one of the front legs, and, on the approach of an insect, the spider whirls it with

surprising speed; this is undoubtedly the way in which it secures its prey. Mr. Longman has repeatedly found the spider sucking a common species of Noctuid moth which it captures in this manner.

**IMPROVED RIVER DISCHARGE MEASUREMENTS.**—In the measurement of river discharge special difficulties are encountered in the case of sluggish streams such as the Blue Nile at Soba during low water. In a report on "Investigations into the Improvement of River Discharge Measurement," Pt. II. (Government Press, Cairo), Mr. E. B. H. Wade gives the result of his experiments with an improved current meter for streams of this type. It is a helical current meter in which the helix is driven not by the stream but by an independent constant power. The effect of the stream is merely to increase or diminish the rate of the helix by an amount which serves as a measure of the stream's velocity. An instrument on these lines is being constructed by Messrs. Kent and Co. The distinctive feature of the model is that gear is dispensed with, and instead of a weight with one or two kilogrammes falling about thirty centimetres, a weight of 25 to 50 grammes falls a distance of one metre. The good results of this model are said to be due, in large measure, to the directness of its action and the avoidance of dissipation of energy in gear work. Experiments made with instruments of this type gave satisfactory results. The probable error for a single determination was found to be  $\pm 0.03$  second, but Mr. Wade believes that this will be reduced in the perfected instrument.

**TURBULENCE ON A LARGE SCALE.**—To say that a gas has viscosity, is a device to compensate in the bulk for the motions which are ignored in detail. Thus if the ignored motions are those within only a cubic tenth of a millimetre the viscosity, for air, is roughly  $0.0002 \text{ cm.}^{-1} \text{ gm. sec.}^{-1}$ . If, however, we ignore the gusts in a wind, then we must attribute to the smoothed wind a much greater viscosity, ranging, in the same unit, from 1 to 100. In this way the increase and veer of the mean wind in the first kilometre above ground have been explained by Åkerblom, Taylor, Hesselberg, Sverdrup, Schmidt, etc. Recently Albert Defant of Innsbruck has gone a stage further by asking what the viscosity must be if we ignore even the cyclones and anticyclones, so that we are left with a smooth general circulation of the atmosphere proceeding along the paths commonly shown in maps of the globe. A review of Defant's first paper on this subject appeared in NATURE of April 15 last, p. 469. In a second paper, "Die Bestimmung der Turbulenzgrößen der atmosphärischen Zirkulation ausser tropischer Breiten" (Wien, Akad. Wiss., 1921), he re-examines, by other methods, the viscosity to be attributed to this general circulation, and finds, as before, values round about  $10^8 \text{ cm.}^{-1} \text{ gm. sec.}^{-1}$ , that is to say, a billion times as great as that arising by ignoring molecular agitation only. This large value,  $10^8$ , applies to friction across vertical planes, but apparently the friction across horizontal surfaces is an affair of gusts, not of cyclones. When the viscosity is known the conductivity for heat and for water vapour can be found by the theories of G. I. Taylor and W. Schmidt. The methods whereby Defant obtains this viscosity include a computation of "eddy-stresses" in accordance with Osborne Reynolds' theory from the hourly values of the wind at various heights. The direct eddy-stresses are in some cases as big as 0.3 millibar. Defant also makes a determination by way of the scattering of air to north and south of the mean-current after a passage of 3 days, using a formula due to L. F. Richardson.

## A Florentine School of Physics and Optics.

By Dr. L. C. MARTIN.

THE city of Florence, deservedly famous as a place of pilgrimage for lovers of art, is no less worthy of a visit on the part of students of science. The famous Museo di Fisica, with its Tribuna di Galilei and its collection of priceless instruments, will always attract the lion's share of attention, but a visit to the charming southern suburb of Arcetri, with the astronomical observatory and the newly erected Institute of Physics and Optics, will amply repay the time spent in making it.

On driving out from the city by the cypress avenue of the Villa Poggio Imperiale, the observatory is seen to the left crowning a lofty hill, on the side of which the red roofs of the Institute can be seen among the green of the surrounding gardens and vineyards. A wide view over the peaceful countryside is obtained on reaching the terrace.

The building is of the square form with centre

under the direction of Prof. A. Garbasso, who, during the last year, has served as Mayor of Florence. The optical laboratory is directed by Prof. A. Occhialini, the well-known editor of the *Revista d' Ottica*. In the coming year it is proposed to build an annexe devoted entirely to technical optics. Up to the present the teaching activity has been restricted to the physical side, but courses on optical subjects are being arranged and research and testing are already in progress. Accommodation is provided for thirty to forty students taking post-graduate courses in physics. The present students are drawn largely from the University of Pisa.

In the course of a short visit it is scarcely possible to notice all the features deserving attention. The arrangement of lecture theatre, class rooms, and research rooms is generally excellent, and it is evident that the needs of experimental work have been considered during design; for example, in one corner of the building it is possible to obtain the equivalent of a vertical circular shaft by removing the coverings of holes in the roof and floors, an arrangement which is of the greatest value in optical testing.

The usual wiring and switch-board for the distribution of electric current is provided, and there is also a separate high-tension circuit. Another point which seems admirable is the construction of the roomy apparatus cupboards in which three sides are of glass; they stand in the corridor on the first floor and exhibit the apparatus to advantage, a matter of importance in a teaching institution.

In the matter of equipment the usual lines have been generously followed. For example, the optical apparatus includes 40 and 20 plate echelons with appropriate spectroscopes, a Fabry and Perot interferometer, and a

Nutting spectrophotometer, all by A. Hilger, Ltd. There is also a large spectrometer (with four reading microscopes for the circle) by the Société Genvoise. Other branches of physics seem to be supplied in a corresponding manner. Those who know something of the present cost of equipment of this kind will appreciate the intensity and vigour of the effort which Italy is making in the founding of this Institute.

In Florence as in few other cities one loses that sense of the remoteness of the past which oppresses the mind in more modern surroundings, and the splendour of bygone days seems still our own for guidance and inspiration. Such thoughts find a fitting expression in two frescoes which are seen on leaving the Institute by the main staircase. On the one side is seen Youth in the quietness and cool of the evening drinking of the fountain of ancient wisdom, while opposite we see Humanity in the glory of morning sunlight pressing upwards with eagerness and hope towards the hillslops.

I am indebted to Profs. Occhialini and Garbasso for photographs and information for the purposes of this article.

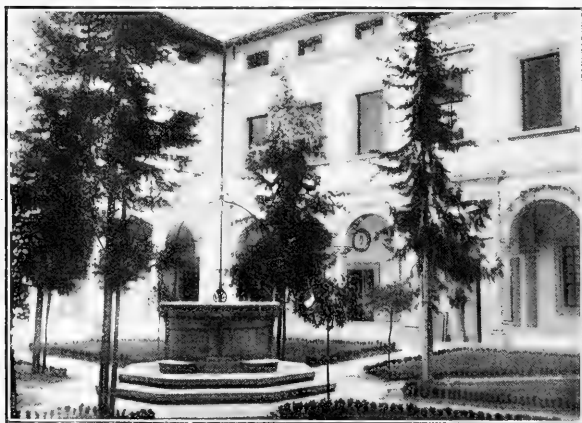

FIG. 1.—The Courtyard of the Physical Institute at Arcetri, Florence.

courtyard usual in Italy, and is only two stories high. A cloister surrounds the courtyard on the ground level, and above the cloister a wide closed corridor affords interconnexion between the rooms on the upper floor. It is commonly held that a similar form of building is not suitable for the British Isles on account of the colder climate, but it may be doubted whether this view is correct; the arrangement has in the present case certainly proved most successful from many points of view. The rooms and corridors are light and airy, while the building is extremely compact and its low height makes for stability. There is little or no trouble from vibration, all machinery being housed in one side of the square at the back of the building. Lastly, and not least, a way has been found to combine beauty with utility, and it was not thought-wasteful even in these modern times to follow the charming traditions of Florence by planting a garden to surround the well in the courtyard. This is shown in Fig. 1.

The Institute was erected immediately after the war to serve for post-graduate and research work in physics and optics. The physical laboratories are

## Fruit-Growing and Research.

THE application of scientific methods and principles is steadily gaining ground in fruit culture as in other branches of agriculture, and the numerous publications on the subject provide evidence of a widening interest in the matter, both as regards the scientific and the practical worker.

The earlier work of Spencer Pickering and the Duke of Bedford stimulated interest in the root systems of fruit trees, and at Long Ashton<sup>1</sup> the matter of root development under various conditions is being followed up. It appears that the method of treatment at the time of planting has little effect on the type of root produced, a new root system being derived from the collar region of the tree and little growth occurring elsewhere; aeration is considered to be a dominant factor in determining the actual point of origin of the new roots. Root formation and growth are most active at the beginning and towards the end of the season, the greatest increase in root length occurring during the latter period, at the time when shoot growth is rapidly decreasing. Other experiments deal with the extension of the root system throughout the soil, a matter which has a direct bearing on the degree of overlapping of roots when too close planting is practised.

On the pathological side special attention has been directed to leaf-scorch on fruit trees, and the trouble has been found to be due to various causative agents. Among the chief of these are unfavourable soil conditions, due to deficient food or water supply or to defective aeration owing to the mechanical character of the soil. Scorching is also attributed to the direct action of wind, to excessive heat falling on the leaf, or to injury to the vascular system of the plant, such as may be caused by ringing or by the presence of a fungus which penetrates the vascular tissue and interferes with the water supply to the leaves.

The importance of spraying to combat disease is now widely recognised, and at East Malling<sup>2</sup> direct

<sup>1</sup> Annual Report of the Agricultural and Horticultural Research Station, Long Ashton, 1921.

<sup>2</sup> Grubb, N. H. (1921), *Journal of Pomology*, II., No. 2.

experimental work is being carried out with fungicides on apple trees. Every fungicide tested reduces apple scab (*Venturia inaequalis*), though the degree of effectiveness varies, Bordeaux mixture usually proving the best. Generally speaking, the crop and the size of the fruit are improved by spraying, with certain exceptions, and there are indications that summer spraying may improve the keeping quality of the fruit by reducing attacks of brown-rot (*Sclerotinia fructigena*). An interesting point is that the effects of spraying are cumulative, sprayed trees being less heavily affected in the succeeding years.

A critical examination of the stocks used for stone fruits<sup>3</sup> shows that little or no attempt has hitherto been made to group them as has been done for those used for apples and pears, rapidity of growth and general availability being usually the deciding factors in the selection of stocks in any particular instance. The descriptions worked out at East Malling are the beginnings of an attempt to set up a permanent standard of classification and identification with the view of the ultimate improvement of stone fruit cultivation.

In an interesting survey on progress in methods of practical fruit-growing in the *Journal of the Royal Agricultural Society of England*,<sup>4</sup> the whole business, from the selection of a holding to the final packing of the fruit, is traced. Laying out and planting the fruit farm, raising and selecting trees, pruning, manuring, diseases, and pests are all brought under consideration in a way that provides suggestive reading for all interested in the subject, and its value is enhanced by a useful bibliography. In this connexion also attention may be directed to the collected leaflets<sup>5</sup> on fruit recently reissued by the Ministry of Agriculture, in which various problems the practical fruit-grower encounters in his work receive detailed consideration.

<sup>3</sup> Hatton, H. G. (1921), *Journal of Pomology*, II., No. 4.

<sup>4</sup> Hatton, H. G., 1921, *Journ. Roy. Agric. Soc., England*.

<sup>5</sup> Collected Leaflets on Fruit, 1921. Sectional volumes, No. 4. Ministry of Agriculture and Fisheries.

## Volcanic Activity in Nigeria.

IN NATURE of July 15, p. 97, an account was given of volcanic activity in Nigeria during March-May last. The following extracts, from the reports of Mr. H. S. Cameron, acting Supervisor of Plantations in Nigeria, furnish some later information. They are placed at our disposal through the courtesy of the Colonial Office:—

On June 17 the manager of Bibundi informed me by telephone that lava streams had commenced to flow again; also that heavy damage was being done by floods. On June 18 I went to Bibundi, and going by trolley to Dollmanshöhe I found the roadway of the bridge entirely swept away by floods and also one of the four piers gone. I went up the river, and after about a mile reached the first flow of lava, which had been advancing the day before but had now cooled and was stationary. Crossing from there to Wernerfelde, progress was shortly prevented by advancing lava; the stream here was molten, but its advance, which was more "creeping" than "flowing," was over a very wide area and on a gentle slope, and it seemed probable that eventually it would cool and turn the main lava stream down the old course of the Njonge river and extend into the sea, as part of the flow was then doing.

The flooding damage was considerable and I think unpreventable; the amount of water is so great that it is impossible to direct it. More than fifty inches of rain fell in the first seventeen days of June, and the water from an area which formerly fed three rivers and part of a fourth has now no channel: not only is an exit lacking, but rain falling on lava does not sink in and percolate through but rushes at once to the lowest level, so free drainage is more necessary than ever.

On June 22 I received a letter stating that the lava had broken through near Dollmanshöhe bungalow, followed the course of the stream, and was threatening the hospital, which had been abandoned. On reaching the bridge-end at Dollmanshöhe on June 25, I found that the whole of that division above the iron road had been covered with lava, and cascades of molten lava were flowing down the banks of the ravine. It was really a wonderful sight. The river bed was full of detached flows of lava fed from the Dollmanshöhe plateau, where it had been massing during the past week. I inspected the whole length from near the Thormahlentfelde bungalow to the director's house, finding flowing lava everywhere. By afternoon the ravine was filled, and by 11 P.M. the lava had crossed the rail where the Government road turns

off and was advancing down the latter and towards it from various points along the river course on the left.

Owing to the steady progress between June 18 and 25, and the rapid flow on the latter date, I considered it advisable to order the removal of all the machinery and the salvaging so far as possible of all building materials worth removing from machine house, cacao house, hospital, and director's house.

On July 11 I again visited Bibundi. The lava had advanced considerably since June 25, but its activity is gradually dying out, though the lava streams from the crater, so far as can be seen in this very misty weather, continue as strong as ever. Probably there will be another period of rest and banking up to be followed by a further advance, and everything points to this following the line of the iron road and Government road to the cacao store and machine house, and possibly breaking through the main portion of Thormählenfelde to the Ninonne River higher up.

On July 15 the manager of Bibundi reported: "The main lava stream is quiet; but for the last three nights I have seen a large new stream coming down the mountain. It is very bright and much closer to this side than before."

### The Royal Photographic Society's Exhibition.

THE Annual Exhibition of the Royal Photographic Society at 35 Russell Square remains open until October 28. Admission is free. The natural history section of the scientific and technical division has improved considerably in recent years. There are still a good many single photographs of an animal, a flower, or an insect that have no particular interest, or if they have it is not indicated; but there are many series showing progressive changes, such as Dr. S. Hastings's nine illustrations of soil formation in the Alps, in which he shows the bare rock covered at first with crustaceous lichens, and traces the stages of vegetation until an alpine meadow is produced. Other series show many varieties of the same kind of thing, as Mr. C. H. Caffyn's thirty sections of calcareous, arenaceous, and igneous rocks, and Dr. Rodman's animal and vegetable hairs. With scarcely any exception the photography in this section is excellent.

Among the "Technical Applications of Photography" Dr. J. S. Plaskett shows four photographs taken at the focus of the 72-inch reflecting telescope at the Dominion Astrophysical Observatory, Victoria, B.C., which also give evidence of the accuracy of figure of the mirror. The Mount Wilson Observatory, Carnegie Institution of Washington, contributes specimens of the work of the 100-inch Hooker reflector and of the 60-inch reflector, as well as photographs of the unusual spectra of seven stars, made with these instruments. Enlarged negative prints of a latitude variation plate and a wave-length plate are among the exhibits of the Astronomer Royal, Greenwich.

The production of accurate comparative scales by photographic means is fully described and illustrated by Mr. A. E. Bawtree, and Mr. Wilfred Mark Webb shows how, by chemical and photographic means, a Russian internal passport was made to yield deleted details which showed that the document had done duty on four separate occasions for as many different persons.

Mr. G. A. Clarke illustrates upper cloud formations which support the theory of Prof. Bjerknes that depressions have their origin in the meeting of a

warm, moist, equatorial current and a cold, dry, polar current. Cloud formation and structure is shown from the upper side by Mr. F. W. Baker.

There are many exhibits that deal with the technicalities of gelatine plate manufacture and the statistical properties of plates by workers in America, as well as in this country. We may refer specially to the beautiful photomicrographs of silver bromide crystals, at 3000 diameters, by Mr. A. P. H. Trivelli, and the characteristic curves of modern high-speed dry plates with photomicrographs of the grains that constitute the sensitive material by Mr. J. W. Grundy. Mr. Grundy also contributes a fine series of photographs taken under various conditions from a height of about 14,000 feet.

Among numerous radiographs by several workers the effect of the Potter-Bucky diaphragm is shown by Mr. R. B. Wilsey. This diaphragm consists of a grid made of parallel strips of lead foil, the planes of which are in line with the direction of the radiation from the tube. It is placed between the patient and the film, and moved during the exposure so that it may not show on the radiograph; it absorbs a large proportion of the scattered rays.

There is a large collection of colour transparencies, and among them some of scientific interest, but the most remarkable are the stereoscopic slides made on autochrome plates by Mr. S. Pegler. The successful reproduction of the colour and the brilliancy of silver plate, various articles of jewellery, and coloured stones, together with the realistic appearance, demonstrates possibilities of this method that are little known. C. J.

### University and Educational Intelligence.

LONDON.—The senate of the university includes sixteen members elected by registered members of convocation and sixteen by the faculties. Of the former, six are elected by the registered graduates in science; and of the latter, the faculty of science appoints four. There are two vacant seats in science, and five candidates have presented themselves as candidates for them. The candidates are: Dr. George Senter, principal of Birkbeck College, and author of a number of papers and other works on chemistry (Dr. Senter is a member of the faculty of science, and is therefore eligible for election as a representative of the faculty in the senate); Mr. T. Ll. Humberstone, an old student and associate of the Royal College of Science, well known to be particularly familiar with the work of the University and educational problems generally; Dr. Jessie White, who is especially interested in methods of teaching science; Dr. J. S. Bridges, director of education, Willesden; and Mr. C. W. Crook, headmaster, Central Secondary School, Wood Green. The poll closes on Tuesday next, Oct. 10, and it is hoped that graduates will not fail to send in their voting papers before that date.

ST. ANDREWS.—The honorary degree of LL.D. was conferred upon the Prince of Wales on September 28. In an address to his Royal Highness after the presentation, Dr. J. C. Irvine, principal of the university, reminded him that St. Andrews was not only a place of beauty and the home of a noble game, but also a centre from which great movements had sprung and powerful influences had spread far and wide. The ancient university was ever ready to enlarge its activities, blending the wisdom of the past with the spirit of progress.

## Calendar of Industrial Pioneers.

**October 8, 1862.** James Walker died.—An eminent civil engineer, Walker constructed many works of the greatest magnitude, and as engineer to the board of the Trinity House built the Bishop's Rock Lighthouse and the Smalls Lighthouse. In 1834 he succeeded Telford as president of the Institution of Civil Engineers, and held that position for eleven years.

**October 9, 1902.** George Wightwick Rendel died.—Born in 1833, Rendel was the second son of James Meadows Rendel. Trained under his father, he gained experience in bridge building in India, and in 1858 became a partner with Armstrong at Elswick, where, with Andrew Noble, he directed the ordnance works for twenty-four years. He was intimately associated with the development of the hydraulic system of gun mountings—the first mounting being fitted in H.M.S. *Thunderer* in 1877—and he was also a pioneer in the application of forced draught to warships. From 1882 to 1885 he was a civil lord of the Admiralty.

**October 10, 1854.** John Augustus Lloyd died.—At an early age Lloyd left England for South America, where he became an officer in the army of Bolivar. In 1827 he made a survey of the Isthmus of Panama. From 1831 to 1849 he was colonial engineer and surveyor of Mauritius, where he constructed many roads and bridges, a patent slip for ships, a break-water, and the colonial observatory. Among his writings was a paper read to the Institution of Civil Engineers on "Facilities for a Ship Canal between the Atlantic and Pacific." He died in the Crimea while on a Government Commission.

**October 11, 1705.** Guillaume Amontons died.—Employed for many years on public works in France, Amontons was a member of the Paris Academy of Sciences, and was known for his improvements in barometers and other instruments. In 1684 he suggested a means of signalling long distances by a type of semaphore telegraph.

**October 12, 1859.** Robert Stephenson died.—The only son of George Stephenson, whom he assisted in the construction of the Liverpool and Manchester Railway, which was opened in 1830, Robert Stephenson became engineer to many of the early railways. Among his most famous works were the High Level Bridge at Newcastle, the Tubular Bridge over the Menai Straits, and the Victoria Bridge at Montreal. He was elected a fellow of the Royal Society in 1849, and during 1856-57 served as president of the Institution of Civil Engineers. He was buried beside Telford in the nave of Westminster Abbey.

**October 13, 1902.** Peter Brotherhood died.—After studying at King's College, London, Brotherhood worked as a mechanical engineer at Swindon and at Maudslay's, Lambeth; in 1867 he set up in business for himself in London. In 1872 he introduced the three-cylinder engine adopted extensively for torpedoes, and in 1875 built the first steam engine coupled direct to a dynamo—this being fitted in the French battleship *Richelieu*. He also made many improvements in air-compressing machinery.

**October 14, 1906.** Sir Richard Tangye died.—One of the five brothers who built up one of the most important engineering works in Birmingham, Tangye and his brothers migrated to that city from Redruth. Setting up as tool and machine makers, they made a reputation by the construction of the hydraulic jacks by means of which Brunel launched the *Great Eastern*, and they afterwards became known all over the world as the makers of steam engines and pumping machinery.

E. C. S.

## Societies and Academies.

SWANSEA.

**Institute of Metals, September 21.**—J. E. Clennell: Experiments on the oxide method of determining aluminium (Report to the Aluminium Corrosion Research Sub-Committee of the Corrosion Research Committee of the Institute). It was desired to find a direct method of determining aluminium in presence of iron and other impurities. Precipitating aluminium as hydroxide by alkali thiosulphates was fairly satisfactory, but the weight of precipitate generally exceeded the theoretical amount calculated from the aluminium known to be present. This excess was traced to small quantities of absorbed substances, notably salts of iron and sulphates, probably of aluminium. A better method is as follows: Pass sulphur dioxide through the slightly ammoniacal solution, precipitating in dilute, faintly acid, boiling solution with sodium thiosulphate with addition of dilute acetic acid, washing by decantation with hot 1 per cent. ammonium chloride, filtering and washing with hot water. Iron, zinc, manganese, and magnesium in ordinary amounts do not interfere, but when the first two are present in large quantity a double precipitation is necessary.—Marie L. V. Gayler: The constitution and age-hardening of alloys of aluminium with copper, magnesium, and silicon in the solid state. *Constitution.*—These alloys have been regarded as a ternary system since magnesium and silicon are added in the proportions of the compound magnesium silicide, which is very stable at all temperatures. Microscopic examination shows that the solubility of copper is reduced from 4.5 per cent. to 2 per cent. at 500° C. by the presence of 0.7 per cent. magnesium silicide; while 2 per cent. of copper reduces the solubility of magnesium silicide from 1.2 per cent. to 0.7 per cent. at 500° C. At 250° C. both constituents are turned out of solution when only 0.5 per cent. of each are present. *Age-Hardening.*—Brinell hardness measurements were made on alloys in which the percentage content of one constituent only was varied; they were quenched from 500° C. and allowed to age-harden at room temperature. Age-hardening is due to the difference in solubility at high and low temperatures of both copper and magnesium silicide, and the solubility in aluminium of both in the presence of each other. Heat treatment of age-hardened alloys caused a preliminary softening before an increase in hardness; this is probably due to the process by which both compounds tend to come out of solution. Derived differential curves of alloys which had been quenched, but not aged, show three critical points; the lowest is at a constant temperature; the temperature of the two upper critical points is lowered with increasing copper content; the intensity of the uppermost varies with the copper content. Probably this point is due to the precipitation of the copper compound and the second to the precipitation of magnesium silicide.—D. Stockdale: The copper-rich aluminium-copper alloys. Alloys of copper with aluminium up to 20 per cent. of aluminium have been investigated. Thermal data from the cooling-curves and from quenching experiments in conjunction with microscopic examination were used to obtain equilibrium diagrams. The minimum in the liquidus curve at 1031° C. with 8.3 per cent. of aluminium is a true eutectic point; a small arrest point at 1017° with alloys containing between 16.5 and 18 per cent. of aluminium has been discovered. Copper at 1000° C. can hold only 7.4 per cent. of aluminium in solid solution; at 500° C. and at lower temperatures, 0.8 per cent., although to obtain such an alloy a

long annealing is required.—R. Seligman and P. Williams: Cleaning aluminium utensils. Aluminium is not attacked by water-glass solutions or by hot soda solution containing a little sodium silicate. Attack by a 5 per cent. soda solution is immediately arrested by the addition of an amount of sodium silicate equal to 1/100 of the soda. Satisfactory detergents consisting of a mixture of soda and sodium silicate are articles of commerce; among them are "Carbosil," "Pearl Dust," and "Aquamol."—W. Rosenhain and J. D. Grogan: The effects of overheating and melting on aluminium. Exposure to an unduly high temperature during melting, and repeated re-melting even at ordinary melting temperatures, are thought to cause deterioration approximating to the condition generally described as "burnt" aluminium. High-grade aluminium was poured at temperatures up to 1000° C. and also at the usual pouring temperature after heating for some hours at 1000° C. The castings rolled and tested in the annealed state showed no deterioration. High-grade aluminium and also aluminium containing 3 per cent. each of iron and silicon were cast to 3-in. slabs and rolled to 0.01 in. sheet; the sheet was re-melted and the process repeated ten times. Test pieces from each melt showed no systematic change.

## SYDNEY.

Linnean Society of New South Wales, July 26.—Mr. G. A. Waterhouse, president, in the chair.—A. E. Shaw: Description of new Australasian Blattidae, with a note on the blattid coxa. Nine cockroaches are described as new, three belonging to Platyzosteria, five to Cutilia, and one doubtfully to Zoniopostera.—H. H. Karny: A remarkable new gall-thrips from Australia. These thrips infest the branchlets of the "Belah" (*Casuarina Cambagei*) and cause rounded galls of aborted tissue to form, in which large colonies of thrips develop.—G. F. Hill: A new Australian termite. The new species of *Calotermes* from near Condon, W.A., is distinct from any described Australian species and easily distinguished in the soldier caste by the long narrow head, large mandibles, dentition, third joint of antennae, and enlarged femora.—E. W. Ferguson and G. F. Hill: Notes on Australian Tabanidae, part ii. Eight new species, including 1 species of *Silvius* and 7 of *Tabanus*, and two varieties of species of *Tabanus* are described.—J. McLuckie: Studies in symbiosis, part ii. The apogonitic roots of *Macrozamia spiralis* and their physiological significance. Root-tubercles occur upon many of the seedlings and older plants of *Macrozamia spiralis*, particularly about the soil-level. They are seldom present on the more deeply situated secondary roots, but may be induced to develop by artificial inoculation. The root-tubercles are due to infection by soil bacteria, the presence of which stimulates the development of the cortex and sheath, so that the tubercles are more massive than ordinary roots.

## Official Publications Received.

Proceedings of the South London Entomological and Natural History Society 1921-22. Pp. xvii + 83. (London: Hibernia Chambers, London Bridge.) 5s.  
Merchant Venturers' Technical College. Calendar for the 67th Session, 1922-23. Pp. 54. (Bristol.) 6d.  
Ministerio de Agricultura, Industria e Comercio: Directoria de Meteorologia. Boletim Meteorologico: Anno de 1912. Pp. 110. Boletim Meteorologico: Anno de 1913. Pp. 130. (Rio de Janeiro).  
Papers of the Peabody Museum of American Archaeology and Ethnology, Harvard University. Vol. 8, No. 3: The Turner Group of Earthworks, Hamilton County, Ohio. By Charles C. Willoughby; with Notes on the Skeletal Remains, by Larnest A. Hooton. Pp. viii + 132-27 plates. (Cambridge, Mass.)  
Smithsonian Institution: United States National Museum. Contributions from the United States National Herbarium. Vol. 23, Part 2: Trees and Shrubs of Mexico (Fagaceae-Fabaceae). By Paul C. Standley. Pp. xxxvii + 171-515. (Washington: Government Printing Office.)

Memories of the Department of Agriculture in India. Entomological Series, Vol. 7, No. 7: New and Rare Indian Odonata in the Pusa Collection. By Major F. C. Fraser. Pp. 39-81. (Calcutta: Thacker, Spink and Co.; London: W. Thacker and Co.) 1.4 rupees; 3s. 3d.  
Annual Report of the Meteorological Observatory of the Government-General of Chosen for the Year 1918. (Results of Observations.) Pp. iv + 134. For the Year 1919. (Results of Observations.) Pp. iv + 143. (Dinsen).  
Sixth Annual Report of the National Research Council. Pp. 72. (Washington: Government Printing Office.)

## Diary of Societies.

MONDAY, OCTOBER 9.

INSTITUTE OF BREWING.—S. K. Thorpe, and others: Discussion on the expenses incurred in connection with the Shipment of Foreign Barley.  
ROYAL SOCIETY OF MEDICINE (War Section) (at Royal Army Medical College, Millbank), at 5.—Lt.-Gen. Sir John Goodwin: Presidential Address.  
TUESDAY, OCTOBER 10.  
ROYAL SOCIETY OF MEDICINE (Therapeutics and Pharmacology Section), at 4.30.—Dr. W. Langdon Brown: The Problems of Asthma (Presidential Address).—Dr. F. Izod Bennett: The Modification of Gastric Function by means of Drugs.  
INSTITUTE OF PETROLEUM TECHNOLOGISTS (at Chemical Society), at 5.30.—Dr. A. E. Dunstan: The Work of the Standardization Committee.  
INSTITUTE OF MARINE ENGINEERS, INC., at 6.30.—A. Keenes: Conditions to get High Economy from Oil Fuel.  
QUEKETT MICROSCOPICAL CLUB, at 7.30.—F. Martin Duncan: Crustacea.  
ROYAL PHOTOGRAPHIC SOCIETY OF GREAT BRITAIN, at 8.—Dr. R. S. Clay: The Development of the Photographic Lens from the Historical Point of View (the Twenty-fifth Annual Traill-Taylor Memorial Lecture).  
INSTITUTE OF HEATING AND VENTILATING ENGINEERS, INC. (at Caxton Hall), at 8.15.—R. Fortune: Some Points in the Law of Heating Engineers' Contracts.

WEDNESDAY, OCTOBER 11.

INSTITUTE OF HEATING AND VENTILATING ENGINEERS, INC. (at Caxton Hall), at 3.—J. L. Musgrave: Heating and Ventilating of Passenger Ships.  
ROYAL MICROSCOPICAL SOCIETY (at Examination Hall, 8-11 Queen Square, W.C.1), at 7.30.—A. Conversazione.  
INSTITUTE OF AUTOMOBILE ENGINEERS (at Royal Automobile Club), at 8.—Lt.-Col. D. J. Smith: Presidential Address.

THURSDAY, OCTOBER 12.

OPTICAL SOCIETY (at Imperial College of Science and Technology), at 7.30.—Dr. L. G. Martin: A Physical Study of Coma.—F. W. Whittaker: The Structure of Sand-blasted and Ground Glass Surfaces.  
INSTITUTE OF METALS (London Section) (at Institute of Marine Engineers), at 8.—Dr. D. Hanson: Chairman's Address.  
ROYAL SOCIETY OF MEDICINE (Neurology Section), at 8.30.—Dr. W. Harris: Toxic Polyneuritis (Presidential Address).

FRIDAY, OCTOBER 13.

ASSOCIATION OF ECONOMIC BIOLOGISTS (in Botanical Lecture Theatre, Imperial College of Science), at 2.30.—Dr. E. J. Butler: Virus Diseases in Plants.—Dr. J. A. Arkwright: Virus Diseases in Animals and Man.  
ROYAL SOCIETY OF MEDICINE (Clinical Section), at 5.30.—(Ophthalmology Section), at 8.30.—N. Bishop Harman: A Visual Standard for School Teachers.  
JUNIOR INSTITUTION OF ENGINEERS, at 7.30.—E. C. West: Artificial Ice Making.  
ROYAL PHOTOGRAPHIC SOCIETY OF GREAT BRITAIN, at 8.—Dr. C. A. Swan: Carcassonne and the Pyrenées.

## PUBLIC LECTURES.

MONDAY, OCTOBER 9.

UNIVERSITY COLLEGE, at 5.—Prof. G. Elliot Smith: The Beginnings of Science.  
KING'S COLLEGE, at 5.30.—Prof. G. B. Jeffery: Einstein's Theory of Relativity.

TUESDAY, OCTOBER 10.

UNIVERSITY COLLEGE, at 5.—Prof. C. Spearman: The Nature of Intelligence.

WEDNESDAY, OCTOBER 11.

UNIVERSITY COLLEGE, at 5.30.—Miss A. S. Cooke, Col. J. M. Mitchell, and Capt. R. Wright: Discussion on Recent Developments in Rural Library Work.—Miss Lilias Armstrong: The Use of Phonics in the Class Room. (As applied to the teaching of French).  
BEDFORD COLLEGE FOR WOMEN, at 5.30.—Prof. E. A. Gardner: Delphi and Delos.

UNIVERSITY COLLEGE, at 7.—A. H. Barker: Standard Ratings for Radiators, Boilers, and Complete Heating Installations.

THURSDAY, OCTOBER 12.

CITY OF LONDON Y.M.C.A. (186 Aldersgate Street), at 6.—Sir Arthur E. Shipley: Fleas, Flies, and Mosquitoes.

SATURDAY, OCTOBER 14.

HORNHAM MUSEUM (Forest Hill), at 3.30.—H. Shaw: Flight in all Ages.



# NATURE

A WEEKLY ILLUSTRATED JOURNAL OF SCIENCE.

"To the solid ground  
Of Nature trusts the mind which builds for aye."—WORDSWORTH.

No. 2763, VOL. 110]

SATURDAY, OCTOBER 14, 1922

[PRICE ONE SHILLING

Registered as a Newspaper at the General Post Office.]

[All Rights Reserved.]

## BALANCES & WEIGHTS



**F. E. BECKER & CO**  
W & J. GEORGE (LONDON) LTD PROPRIETORS  
17 to 29 HATTON WALL, LONDON, E.C.1

**REYNOLDS & BRANSON, Limited,**  
Chemical and Scientific Instrument Makers to His Majesty's  
Government (Home and Overseas Dominions), Laboratory  
Furnishers and Manufacturing Chemists.

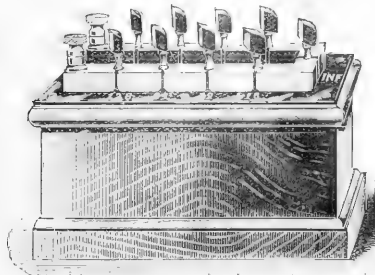

Resistance Boxes, P.O. Boxes, etc., manufactured in our own  
Workshops.

See Physical Catalogue. Post free on application.

**14 COMMERCIAL STREET, LEEDS.**

## SPECTROMETERS

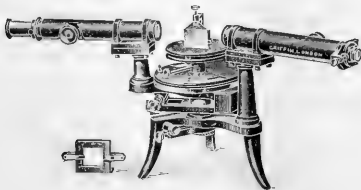

Particulars and Prices on application to—

**JOHN J. GRIFFIN & SONS, LTD.**

Kemble Street, Kingsway,  
London, W.C.2.

NEGEHRETT & ZASTRA



**CERTIFICATE  
— OF —  
EXAMINATION  
of  
Fahrenheit Thermometer No. 0.10280, etc.**

Name of Thermometer — *deyrett & Zastrá*.

Comparison is applied to the Scale Readings determined by comparison with the Standard Instruments in the National Physical Laboratory, Teddington. The corrections are such as to nearest 1/10°.

TEMP. IN	TEMP. IN °
0.000	0.000
1.000	0.000
2.000	0.000
3.000	0.000
4.000	0.000
5.000	0.000
6.000	0.000
7.000	0.000
8.000	0.000
9.000	0.000
10.000	0.000

Note 1. When the age of the instrument is given, the date of the last examination is also given.

Note 2. The instrument is not to be used for any purpose other than that for which it is designed.

Note 3. The instrument is not to be used for any purpose other than that for which it is designed.

Note 4. The instrument is not to be used for any purpose other than that for which it is designed.

Note 5. The instrument is not to be used for any purpose other than that for which it is designed.

Note 6. The instrument is not to be used for any purpose other than that for which it is designed.

Note 7. The instrument is not to be used for any purpose other than that for which it is designed.

Note 8. The instrument is not to be used for any purpose other than that for which it is designed.

Note 9. The instrument is not to be used for any purpose other than that for which it is designed.

Note 10. The instrument is not to be used for any purpose other than that for which it is designed.

NEGEHRETT & ZASTRA

**BATTERSEA POLYTECHNIC.**

Principal—**ROBERT H. PICKARD, D.Sc., F.R.S.**

University Courses, day and evening, under Recognised Teachers of the University of London are provided in Science, Engineering and Music. CHEMISTRY.—**J. KENYON, D.Sc., F.I.C.; \* J. L. WHITE, D.Sc. PHYSICS.—S. MARSH, B.Sc., Ph.D.; \* A. E. EVANS, B.Sc.; \* J. F. PHILLIPS, B.A., B.Sc. MATHEMATICS.—\* F. M. SANBURY, M.Sc., B.A.; \* F. W. HARVEY, B.Sc., M.A.; \* W. G. RICKLEY, M.Sc. MECHANICAL AND CIVIL ENGINEERING.—\* W. E. M. CURRAN, M.Sc., B.Eng.; \* J. B. SHAW, A.R.C.S., Wh.Eng.; \* H. M. FIDELL, B.Sc.; \* V. C. DAVIES, B.Sc., A.M.I.Mech.E. ELECTRICAL ENGINEERING.—\* A. T. DOVER, M.I.E.E., A.A.I.E.E.; \* H. C. MANN, A.M.I.E.E. MUSIC.—**H. D. WILTON, Mus. Doc., F.R.C.O.****

\* Denotes recognised teacher of University of London.

There are also:—

Day Technical College in Engineering and Science. Day Training College of Domestic Science. Day Department of Hygiene and Physiology. Day School of Art and Crafts. Evening Courses in Engineering, Chemistry, Physics, Mathematics, Bacteriology, Chemical Engineering, Hygiene and Physiology, Art, Matriculation Subjects, Domestic Economy, Music, Physical Training. Hostels for Women Students. Large playing fields at Merton.

**UNIVERSITY OF ABERDEEN.**

**BLACKWELL PRIZE ESSAY.**

The BLACKWELL PRIZE OF THIRTY GUINEAS, Open to Unrestricted Competition, will be awarded in 1923 for the Best Essay on "The Sculptured and Inscribed Stones of the North-east and North of Scotland." Essays must be lodged with the SECRETARY of the UNIVERSITY on or before January 1, 1923.

Each Essay must bear a Motto, and be accompanied by a Sealed Envelope bearing the same Motto, and enclosing the Name and Address of the writer.

H. J. BUTCHART, Secretary.

Marischal College, Aberdeen.

**LEEDS GRAMMAR SCHOOL.**

The GOVERNORS invite applications for the Post of HEADMASTER of this School.

The School is a Day School. Present Numbers, 600. Advanced Courses in Classics, and in Mathematics and Science.

Applicants must hold Honours Degrees of a University in the United Kingdom or the British Dominions.

Salary £1200, rising by annual increments of £50 a year to £1300.

House free of rent, rates, and external repairs provided.

Duties to begin as from January 1, 1923.

Applications, with references and 20 copies of not more than 3 recent testimonials, to be sent in 50 as to be received not later than October 31, 1922, to the CLERK to the GOVERNORS, 6 Butts Court, Leeds.

**UNIVERSITY OF BIRMINGHAM.**

**LECTURER IN PHYSIOLOGICAL DEPARTMENT.**

GRADE III.

The Council invites applications for the above post. Commencing stipend £300 per annum.

Applications, with testimonials, should be sent to the undersigned not later than October 16. No special form of application is required.

The Candidate elected will be required to enter upon the duties at once.

The conditions of appointment for Grade III, and for promotion to Grade II on the University Staff may be obtained from

GEO. H. MORLEY, Secretary.

**BACTERIOLOGICAL INCUBATOR,**

HEARSON'S, in good working condition, with patent Gas Regulator, FOR SALE, inside measurement 15" x 15" x 18", supplied by Messrs. Baird & Tatlock. Inspection and offers invited. PROPAGANDA MANAGER, S/Ammonia, 30 Grosvenor Gardens, S.W.

**LABORATORIES available up to 4000 square**

feet, well equipped, suitable Chemical, Physical, Electrical, or Bacteriological purposes, together with telephone and office facilities. Within seven minutes of Bank. Box 20, c/o NATURE Office.

**SCIENTIFIC APPARATUS MAKERS**

Wanted. First-grade men with electrical knowledge. Apply, stating experience, age, and wages required, to REYNOLDS & BRANSON, Ltd., Leeds.

**WANTED TO PURCHASE: Messenger**

of Mathematics, Vols. 31 to 40; Quarterly Journal of Mathematics, 1910-21. Priced offers to W. MULLER, 26 Hart Street, London, W.C.1.

**PALAEOLITHIC IMPLEMENTS, French**

1 British. Sets of five, one guinea. State requirements. Approval. ORILL, 22 Glenlyon Road, S.E.9.

**CHELSEA POLYTECHNIC,**

CHELSEA, S. W. 3.

Day and Evening Courses in Science under Recognised Teachers of London University.

- I. INDUSTRIAL CHEMISTRY DEPARTMENT.**  
Technical Courses in Analytical and Manufacturing Chemistry, Pharmacy, Food and Drugs, A.I.C. Courses, Metallurgy, Assaying, Foundry Work, Research.
- II. INDUSTRIAL PHYSICS DEPARTMENT.**  
Practical work in General Physics, Applications to Industries, Metrology, Calorimetry, Illumination, Acoustics, Electrical Measurement, Research.
- III. BIOLOGICAL AND GEOLOGICAL DEPARTMENT.**  
Courses for B.Sc., etc., in Botany, Geology, Mineralogy, Zoology, Special Courses in Bio-chemistry, Bio-physics, Bacteriology, Physiology, Hygiene, Entomology, Plant Pathology. Course for Tropical Planters, Research.

SIDNEY SKINNER, M.A.,  
Principal.

Telephone: Kensington 899.

**GRESHAM COLLEGE,**

BASINGHALL STREET, E.C.

Mr. ARTHUR R. HINKS, C.B.E., M.A., F.R.S., Gresham Lecturer on Astronomy, will give four Lectures on "ASTRONOMY WITH MODEST MEANS" on Tuesday, Wednesday, Thursday, and Friday, October 17-20 at 6 P.M.

Admission free to men and women.

**LANTERN SLIDES  
FOR LECTURES, ETC.**

Prepared at short notice from photographs, drawings, diagrams, etc.

W. KING & CO., Southsea Road, Kingston-on-Thames.

**The Misses FARRAN**  
**10 Bell Yard, Temple Bar, W.C.2,**  
**HAVE CONSIDERABLE EXPERIENCE IN**  
**COPYING SCIENTIFIC MS.**  
AND ARE PREPARED TO  
UNDERTAKE ANY QUANTITY.

**THE GENERAL DISCUSSIONS OF  
THE FARADAY SOCIETY.**

The SECRETARY will send on application the latest list of available REPRINTS.—10 Essex Street, London, W.C.2.

**THE HANDBOOK OF  
PATENT LAW OF ALL COUNTRIES**

By **W. P. THOMPSON, F.C.S., M.I.Mech.E., Etc.,**

Chartered Patent Agent of Liverpool.

Entirely revised and rewritten 1920. 157 pages. Crown Octavo.

All Countries, 6s. British Law only, 1s.

"Should prove a very valuable and trustworthy guide to would-be patentees."—*Nature*.

LONDON: STEVENS AND SONS, LIMITED.

If you are in need of any **SECOND-HAND BOOK** on **Natural History or Science** apply

**DULAU & CO., Ltd.,**

Established 1792. 34, 35, 36 Margaret Street,  
Libraries purchased. Cavendish Square, London, W.1.



SATURDAY, OCTOBER 14, 1922

CONTENTS.

	PAGE
Landowners and the State . . . . .	501
Bergson and Einstein. By Prof. H. Wildon Carr . . . . .	503
The Molecular Scattering of Light. By H. S. A. . . . .	505
Technical Electricity . . . . .	506
Modern Metallurgy. By W. H. M. . . . .	507
The British Association Addresses of 1922 . . . . .	507
Our Bookshelf . . . . .	508
Letters to the Editor :—	
Periodicities.—Dr. Gilbert T. Walker, F.R.S. : Sir W. H. Beveridge, K.C.B. . . . .	511
One Possible Cause for Atmospheric Electric Phenomena.—A Query.—Sir Oliver Lodge, F.R.S. . . . .	512
School Instruction in Botany.—Dr. Lilian J. Clarke Transcription of Russian Names.—J. G. F. Druce and A. Glazunov . . . . .	512
Colour Vision and Syntony.—Dr. F. W. Edridge- Green . . . . .	513
The Green Ray at Sunset and Sunrise.—Prof. Alfred W. Porter, F.R.S. . . . .	513
Photography of Bullets in Flight. (Illustrated.) By Philip P. Quayle . . . . .	514
The Study of Man. By H. J. E. Peake . . . . .	516
Obituary :—	
Dr. David Sharp, F.R.S. By H. S. . . . .	521
Dr. William Kellner . . . . .	522
Current Topics and Events . . . . .	522
Our Astronomical Column . . . . .	525
Research Items . . . . .	526
The Fauna of the Sea-Bottom. By Dr. C. G. Joh. Petersen . . . . .	527
Adhesives. By Emil Hatschek . . . . .	528
The Decomposition of Tungsten . . . . .	529
The Belt of Political Change in Europe . . . . .	529
University and Educational Intelligence . . . . .	530
Calendar of Industrial Pioneers . . . . .	531
Societies and Academies . . . . .	531
Diary of Societies . . . . .	532

Editorial and Publishing Offices :

MACMILLAN & CO., LTD.

ST. MARTIN'S STREET, LONDON, W.C.2.

Advertisements and business letters should be  
addressed to the Publishers.

Editorial communications to the Editor.

Telegraphic Address: PHUSIS, LONDON.

Telephone Number: GERRARD 8830.

NO. 2763, VOL. 110]

Landowners and the State.

Lord BLEDISLOE, as president of the Agricultural Section of the British Association at Hull this year, struck a new note in his address. Put very briefly, his text was a demand for more leadership, and in particular for educated leadership by landowners in the business of farming. British farming has for the last two centuries in the main been carried on by tenants possessed of considerable capital, which is employed in the business and not in the land itself nor in its permanent equipment. The result, at any rate until fifty years ago, was successful. Complicated as the question of tenure was in detail, by custom it worked well on the whole; a sufficiency of capital was attracted to the land to permit of cultivation on a comparatively large scale with sufficient continuity to encourage experiment and improvement, until British farming, whether as regards operations of cultivation, productivity of crops grown or quality of stock bred, stood easily foremost in the whole world.

British agriculture no longer enjoys the same undisputed position. We can still point with pride to its technical excellence, but it has not succeeded in so adapting itself to the changed economic conditions as to continue to be regarded as a prosperous industry or to attract the confidence of capitalists. Farmers, despite some protestations, can still make a living out of it, because they can always adjust their style of farming to any range of prices, but the position of the other two parties to the occupation of the land is far from satisfactory. Landowners' rents do not represent a reasonable rate of interest on the money that has been expended on the buildings, etc. necessary to the working of the farm. A piece of average English land in prairie condition could not to-day be equipped as a farm and then let at a rent which would pay market interest on the capital expended in equipping it, even though no charge were made for the land itself. Landowners who sold their farms during the last few years were able after reinvestment to double and treble the income they had derived from them, and at the same time to relieve themselves of many of the calls upon the landlord's purse. Agricultural labourers, again, though they effected some improvement in their position during the war, are still the worst paid industrial class of any magnitude in the community. In the villages it is well recognised that a boy is likely to be better off if he can get on the railway, into the police, or any of the other occupations more or less available, rather than go upon the land.

The tenant-farming system, for all its advantages, appears to be breaking down, and Lord Bledisloe regards the landowners of the last generation or two

as in part responsible. From an abstract point of view the ordinary English tenant farm of 200 to 500 acres is no longer the economic unit it once was. At its inception it represented wholesale large scale production as compared with the generality of European farming, and as such it provided the food needed for the early industrial development of the country.

But with the enormous extension of wheat growing and meat production in the newer countries, the effect of which upon our markets began to become so apparent from the 'seventies of last century onwards, and with modern organisation of the import trade in food products from countries with a low wage standard, the English farmer no longer controls prices, and when he stands alone, he is selling as a retailer in a market dominated by much larger interests. It has become a terribly difficult market because Great Britain is now the one absolutely free emporium to which the surplus food products from every other food-producing country in the world are directed. With one or two minor exceptions (Denmark and Belgium are practically free-trade countries, but they are normally food exporters rather than buyers), the British farmer is met by a tariff wall whenever he has a surplus to export or a speciality to develop, and these difficulties are, at the moment, accentuated by the break in the Continental exchanges, which diverts to Britain even the limited quantities of food-stuffs the foreign industrialist had begun to purchase.

Some of these difficulties may be overcome by co-operation, never an easy matter to organise in a conservative community such as our farmers form, bred as they have been in an individualist organisation of business and imbued with the characteristic British tradition of standing alone. In any case, co-operation may be only a palliative; the economic flaw in the tenant-farming system probably is that the unit of management is too small. There is not work for a master in controlling the five to ten men employed on the ordinary English farm; as a managing head one man should be able to supervise the working of 1000 to 2000 acres, according to the class of land. Economic pressure would thus appear to be tending to move away from the present type of British farm in two directions, either towards the single-man holding, uneconomic as an instrument of production but in which compensation is found in the extra labour the occupier will give in exchange for his independence, or on the other hand, towards the really large farm which can take advantage of machinery and organisation.

Lord Bledisloe's main contention is that the landowner must either take the latter option and become the instructed business head of his estate treated as a single farm, or if he prefers not to take over the actual manage-

ment, he must at least be the leader and *entrepreneur* of the associated businesses of his tenants. Not only is the holding of land a bad investment, but in a modern State the mere rent receiver will eventually be eliminated. Landlords must give service or perish as such, and Lord Bledisloe appeals to a class which has a long and honourable tradition behind it of service to the State to return to the land and so render a necessary service to a State that is becoming overweighted on the industrial side. He points out the two directions in which the landowner can lead his tenants and benefit both his estate and the course of agriculture. In the first place, the farmer to-day is not getting his fair share of the prices the consumer pays for food. While all the producing interests connected with the land are unprosperous and are being forced to contract their activities, the trading organisations which deal in the produce of land are paying handsome dividends and individual middlemen are growing rich. The consumer reviles the farmer because of the scarcity of food; the farmer knows he must restrict his production in order to make it pay at present prices, while the slightest production above the normal demand cuts away not merely profits but often cash returns, as may be seen over plums and potatoes at the moment. The distributing trade has entrenched itself in order to retain its war scale of margin, and the building famine in the country hinders the growth of competition. Lord Bledisloe gives a series of tables to show the discrepancy between retail and farmers' prices and the increase of that discrepancy since the war; in most cases the distributing trades take more than half the price the public pays. Coarse 'middlings' cost more than wheat, and readers of the *Times* a few days ago may have noticed that on the same day the price of London flour was put up while wheat was, in another column, reported as cheaper.

It is to this state of things Lord Bledisloe recommends landowners to turn their attention; can they not organise the businesses of their farmers into something capable of keeping the middlemen in check? They should be able to see further than the farmer, who has to look after his own business of production. Co-operation has made but little headway among farmers themselves; would it not be in a very different position if it had been whole-heartedly and intelligently backed by the landowners? Here is one opening for intelligence and leadership on the part of owners of land.

The other great opening is in connexion with education and research. The old race of landlords numbered among them great improvers of farming, such as Weston, Townshend, Coke, and Lawes. Even the much-abused farming covenants represented, to begin

with, better systems imposed upon their tenants by landlords. To-day, if English farming practice is in many respects still ahead of its competitors, it has become, comparatively speaking, not so alive to the applications of science. Farmers themselves are not quite what they were; the great industrial development of the last sixty years has been drawing away the brains from the more slowly moving pursuit of agriculture, and, speaking broadly, the present race of farmers are not educated up to their needs or their opportunities.

Here again the landowners have not been, but can be, leaders; they can become intelligence centres, they can stimulate the education of their tenants and of their tenants' sons, they can even insist on education in selecting their tenants. It is the lack of appreciation of science among landowners that has made it a plant of slow growth among their tenants.

The address is really a powerfully worded appeal from Lord Bledisloe to the landowning class to treat landowning as a vocation and to educate themselves for it. It is a far-sighted call for service, and coming from one who has so notably put into practice what he preaches, carries with it an authority which no ordinary admonition to progress can possess.

### Bergson and Einstein.

*Durée et Simultanéité: À propos de la théorie d'Einstein.* Par Henri Bergson. Pp. viii + 245. (Paris: Félix Alcan, 1922.) 8 francs net.

EINSTEIN in his theory of relativity may be said to have thrown down a challenge in the scientific world of the same kind as that which Bergson in his theory of duration has thrown down in the philosophic world. Both theories are primarily concerned with a certain fundamental character in the experience of time. Both recognise a difference of nature, that is, a qualitative difference, between the time which enters into our equations of measurement and the time which is lived. At one point, however, Bergson seems to come into direct conflict with the Minkowski-Einstein scheme of a space-time continuum. This is in his conception of creative evolution. Creation means that the reality of the physical universe is of the nature of life or consciousness, a conception which implies the continued existence of the past in the present, and a universal moving forward into an open future. How is this consistent with the view that there is not one single universal time but as many different times as there are systems, and that there is no absolute simultaneity between events which take place at any two points if they are separate from one another in space?

Bergson has evidently been of opinion that for his own sake he must clear up his position on this crucial point. To do so has been no slight undertaking, for he has not been content to accept the principle of relativity from the physicists or to assume that its mathematics is correct. He has, therefore, deferred the resumption of his own philosophical work, interrupted by the war, and has set himself to study at first hand the mathematical equations of Lorentz and Einstein. It may interest readers of NATURE to know that Bergson specialised in mathematics in his student days to the extent of hesitating between it and philosophy when he had to choose a profession. The argument in his new work deals almost exclusively with the restricted theory, for it is that which affects directly the question of the reality of time. The relevance of the generalised theory is only touched upon. It is the subject of a "Final Remark," in which the nature of its importance for philosophy is indicated, but general relativity does not seem to Bergson to challenge, as the restricted relativity does, his theory that time as a universal flux or change is an intuited reality, while successive states are a spatialised time due to the intellectual mode of apprehending it.

Descartes in the Principles (ii. 29) declares that in movement there is complete reciprocity; either of two objects changing their relative position may be considered as having moved or as having remained at rest. To this Sir Henry More replied (March 5, 1649): "When I am sitting still, and someone moving away a mile from me is red with fatigue, it is he who moves and I who am still." Nothing science can affirm concerning the relativity of perceived movement, measured by foot-rules and clocks, can disturb the inward feeling we have that we ourselves can effect movements and that the efforts we put forth in doing so are under our control. Here we have, then, in the most striking manner, the contrast between the intuitive mode and the intellectual mode of apprehending reality. Is there anything in the principle of relativity which conflicts with the conception of reality as fundamentally a duration which is intuited or lived? *Prima facie*, yes. The denial of absolute simultaneity seems completely inconsistent with it. This comes out most clearly in Einstein's paradox. "Suppose a traveller to be enclosed in a cannon-ball and projected from the earth with a velocity amounting to a twenty-thousandth of the velocity of light; suppose him to meet a star and be returned to earth; he will find when he leaves the cannon-ball that if he has been absent two years, the world in his absence has aged two hundred years." Any one who applies the mathematics of relativity and makes the simple calculation for the two systems, earth and cannon-ball, will find that the conclusion

follows with the same logical necessity as in Zeno's paradox that Achilles cannot overtake the tortoise.

There is, however, a limitation even for the relativist which, although it falls short of establishing an absolute, is important to keep in mind. There is no system of reference which a traveller can choose, by entering which he might depart and return to find the world younger, so that his journey would have been backward in time. The reason is not the inconceivability of such a system, but the fact that it would bring us into conflict with the law of causality. The reversibility of causality which would require the effect to come into existence before the cause, is unthinkable. Such then is the paradox. Relativity requires that as we pass into a new system of reference the relative movement of the new system shall be compensated by changes in the spatio-temporal axes of co-ordination in order to keep constant the velocity of light. This means in the case supposed that two years of the one system is the equivalent of two hundred of the other.

Bergson's solution of Einstein's paradox follows the same line as his solution of the paradoxes of Zeno, but the special application of his principle has a particular interest. In the case of Zeno the essential point was the insistence on the continuity, in the meaning of absolute indivisibility, of true duration, the duration which is lived and intuited, as distinct from the infinitely divisible continuity, mathematically defined, of the schematised trajectory of the movement. The mathematical time which we measure is really space. In the case of Einstein's paradox Bergson argues that the two systems, which are discordant as to their simultaneity when taken as integral systems, must be considered as continuously related, and this is possible only so long as we do not abstract from the observer who is attached to each. If, he says, we consider the two observers in their different systems to be continuously in communication it is clear that each, while regarding the other as a physicist co-ordinating a system, will regard that co-ordinated system from the standpoint of his own, and therefore, however different the system may be, in so far as the two observers are physicists and in so far as they are related observers, the duration intuited is one and the same for both. But here we shall ask, if the explanation is so simple, how does the paradox arise? Quite naturally, Bergson replies, and this is the striking part of his argument, because what the philosopher can do the physicist cannot. The philosopher's concern is with reality perceived or perceptible; he, therefore, can never lose sight of the interchangeability of the two systems. He keeps them together by a kind of continual coming and going between them. The physicist, on the other

hand, whose only business is to co-ordinate the system as a whole, must choose one and stand by his choice. He cannot relate all the events of the universe to two systems of different axes of co-ordination at one and the same time. He must therefore regard the whole system as concordant or discordant with the whole of the other system, each taken as one and integral. For the physicist is not concerned with time intuited but only with time as a measurable dimension.

We may see, then, how Einstein is able to affirm that there are multiple times. We can place an imaginary physicist at every point of space and his time-system will necessarily be different from every other time-system; and our own time-system, so far as we are physicists, has no privilege over the imaginary time-systems. But, Bergson replies, into whichever of these imaginary time-systems we project ourselves, it becomes thereby time lived or intuited, and as we can conceive ourselves to pass into any of them, there is a real duration to which all the imaginary time-systems belong. Thus is restored to us the unique time, one and universal.

Such is Bergson's solution. Does it dispose of the problem? The argument is certainly calculated to reassure those who have been disturbed by the principle of relativity, and to comfort those who are made unhappy, rather than stimulated to activity, by paradox. Yet there are many indications in his book that Bergson himself does not feel he has said or is now saying the last word. In the final remark, to which we have already referred, he regards the generalised theory as an extension of the argument of the restricted theory with the difference that the emphasis is on space rather than on time. He suggests that the treatment of space on the same lines as those on which he has dealt with time would show that the multiple geometries are imaginary physicists' geometries abstracted from their relation to and transformability into the one and universal space-system which is the intuition of the living individual.

To a certain extent he is undoubtedly right, for we may say truly that the restricted relativity is a case in point of the generalised relativity. But there is a problem which Bergson has left untouched while giving indications that he is aware of it. This is the relativity of magnitudes. Even Einstein has not, so far, dealt with it specifically. Weyl, in his endeavour to make the generalised theory include the whole realm of electro-magnetic phenomena, has foreshadowed a relativity even more fundamental and more universal than Einstein's, although so far he has found no means, such as Einstein found, of submitting the principle to experimental tests. In philosophy it is of the deepest significance. Not only is there no

absolute criterion of magnitude, but systems of reference are not even relatively in relations of magnitude to one another. It is only for the observer in a system of reference that there is a relation of magnitude within the system and that the system itself has relations of magnitude to other systems. Into whatever system an observer passes he carries into it his own constant norm of magnitude and he does not have to submit to the dimensions which the new system imposes on him. It is this aspect of the principle of relativity which has seemed to the present writer to require a philosophical principle like that of the Leibnizian monad to give it full expression. It is not enough to return to the mathematical principle of Descartes's mechanism. Mathematics and physics alike rest ultimately on the experience of active subjects, and this is why experimental tests are relevant. The monadic conception derives new meaning from the theory of reality as psychical duration, the concept which Bergson has made a new possession of human thought.

II. WILDON CARR.

### The Molecular Scattering of Light.

*Molecular Diffraction of Light.* By Prof. C. V. Raman.

Pp. x+103. (Calcutta: University of Calcutta, 1922.)

READERS of NATURE are already familiar with the important work which Prof. C. V. Raman has been carrying out in connexion with the scattering of light by small particles, for many of his results have been announced in these columns. In a small volume published by the University of Calcutta he has reviewed the present position of the subject of molecular diffraction of light, and has discussed the theory in a comprehensive survey which includes the case of gases, vapours, liquids, crystals, and amorphous solids.

Lord Rayleigh was the first to indicate the principles on which the problem may be handled, and he obtained a relation between the scattering power of the molecules of a gas, their number per unit volume, and the refractivity of the medium. As the energy scattered must be derived from the primary beam, the intensity of the latter must suffer an attenuation as it passes through the medium, and an expression can be derived for the attenuation coefficient. Prof. Raman discusses some criticisms of the theory and concludes that the principle of random phase which is assumed in the argument is justified, provided there exists the random distribution of the molecules which is required by Boyle's law. The ultimate justification of the principle rests on the complete non-uniformity in the spatial distribution of the molecules in so far as very small volume elements are concerned.

The first successful attempt to observe the scattering

of light by dust-free air in the laboratory was made by Cabannes in 1915. Experimental work of great interest has been carried out by Prof. R. J. Strutt (the present Lord Rayleigh), who obtained the remarkable result that, in many gases, the scattered light is only partially polarised. This may be explained as due to the lack of symmetry of the molecules, and may furnish valuable information with regard to molecular configuration.

To the late Lord Rayleigh we owe the brilliant suggestion that the scattering of light by the molecules of air accounted in large measure both for the blue light of the sky and the observed degree of transparency of the atmosphere. Recent observations, principally at the Observatory on Mount Wilson, have confirmed the theory and have furnished a value for Avogadro's constant which is practically identical with that deduced from Millikan's measurements of the electronic charge. Prof. Raman has made observations on the polarisation of skylight on Mount Dodabetta (8750 feet above sea level) in the Nilgiris. As is well known, dust and haze are largely confined to the lower levels of the atmosphere. The influence of secondary scattering may be reduced very considerably by using a deep red filter, and allowance can be made for the effect of earthshine. The weaker component of polarisation was found to have 13 per cent. of the intensity of the stronger component. Only 4 per cent., however, was ascribable to molecular anisotropy, a result in good agreement with the latest laboratory measurements.

The principle of random phase on which Rayleigh's theory depends is not applicable in the case of highly condensed media such as dense vapours, liquids, and solids. In liquids, we may apply the theory developed by Einstein and Smoluchowski, in which scattering is considered not as due to individual particles but to small local variations of density arising from the heat movements of the molecules. A formula is obtained showing how the scattering power of a fluid is related to its refractivity. It is worthy of notice that the scattering power is proportional to the absolute temperature and to the compressibility of the liquid. When corrected for the effect of molecular anisotropy, the formula gives results in fair agreement with observations in non-fluorescent liquids, and it reduces automatically to the Rayleigh formula in the case of gaseous media. But, surprisingly enough, the law seems to break down in the case of gases under high pressure. Prof. Raman makes the interesting suggestion that this failure may mean that the continuous wave theory of light does not strictly represent the facts, and that we may perhaps find here experimental support for Einstein's conception that light itself consists of quantum units.

The colour and polarisation of the light scattered in the sea is discussed by Prof. Raman in a chapter which must interest biologists as well as physicists. The colour of the deep sea is not mainly due to reflected skylight, as has sometimes been suggested, but to light molecularly diffused from within the water. The reflecting power of water at normal incidence is quite small (only 2 per cent.), and consequently to an observer flying at a great height above the surface of the water the luminosity of the sea would be determined almost entirely by internal scattering.

In crystals such as quartz and rock-salt the scattering of light can be observed visually, the Tyndall cone being of a blue colour. The effect may be attributed to the thermal movement of the atoms in the crystal introducing local fluctuations of optical density. Thus there is a close connexion between this phenomenon and the well-known influence of temperature ("Debye effect") on the intensity of X-ray reflection as illustrated, for example, in the experiments of Sir W. H. Bragg on rock-salt. It may be suggested that further study of the scattering of light in amorphous solids like glass would yield information of value regarding the molecular structure of such bodies.

H. S. A.

### Technical Electricity.

- (1) *Principles of Electrical Engineering*. By Prof. W. H. Timbie and Prof. Vannevar Bush. Pp. viii + 513. (New York: J. Wiley and Sons, Inc.; London: Chapman and Hall, Ltd., 1922.) 20s. net.
- (2) *High Voltage Power Transformers*. By W. T. Taylor. Pp. x + 117. (London: Sir I. Pitman and Sons, Ltd., 1922.) 2s. 6d. net.
- (3) *Electric Power Systems*. By W. T. Taylor. Pp. xii + 107. (London: Sir I. Pitman and Sons, Ltd., 1922.) 2s. 6d. net.

(1) THIS book is intended for students of electrical engineering. Although much of the ground has been covered in a similar way before, yet there are several novel features. The magnetic circuit—the importance of the theory of which in electrical engineering can scarcely be over-estimated—is allotted the space it deserves. The electron theory, which is admirably adapted for giving easily intelligible explanations, is freely used. Thermionic emission, conduction through gases, and electrolytic conduction are all discussed. There are also about 500 practical problems, some of which give interesting engineering data.

The authors divide electrical engineers into three classes. The first class comprises the men who apply scientific laws to electrical development. This includes

the research engineer and the designer. The second class includes the distributing engineer who plans, constructs, and operates power-transmission lines, telephone and telegraph circuits, and electric railway systems. There is, finally, the engineer who acts as liaison officer between electrical engineering and civil and mechanical engineering, including all industrial applications. The consulting engineer and the promoting or "commercial" engineer belong to this class. This type of engineer must be well grounded in economics, and well versed in business, law, and procedure.

The authors state that the terminology they use is that recommended by the American Institute of Electrical Engineers. It differs in several important respects from that recommended by the International Electrical Commission. The Gauss is defined as the unit of magnetic induction density. In I.E.C. nomenclature the unit of magnetic induction density is one Maxwell per square centimetre. In Europe the Gauss is defined practically always as the unit of magnetic force. The authors take as the unit of magnetic force "one Gilbert per cm.," and the unit of reluctance is called the "Oersted." We do not think that the Gilbert and the Oersted will be accepted internationally. In our opinion also a case has not been made out for the use of such words as "abohm," "abvolt," "statvolt," etc. Abohm is the unit of resistance in the absolute system of units and "statvolt" is the unit of electric pressure in the electrostatic system of units.

In discussing sparking voltages between spherical electrodes (p. 417), it is stated that "small balls with a given separation break down at a smaller potential than large balls." This is not true in all cases. Russell (Journ. I.E.E., vol. 57, p. 228), for example, states that for half a centimetre spark at 25° C. and 76 cm. the disruptive voltages for spheres of 1 cm., 5 cm., and 25 cm. radius are 17.7, 16.3, and 15.0 kilovolts respectively. It will be seen that the voltages required for a break-down in this case are appreciably higher for the small electrodes. For still smaller-sized electrodes for the same air-gap the disruptive voltages get smaller. Similarly when the air-gap is 1 cm. it can be shown that the sparking voltage has its maximum value of 32 kilovolts when the diameters of the electrodes are each equal to 2 inches very approximately.

(2) Mr. Taylor's book will be of interest to the electrical engineer, as it discusses problems in which he takes great interest. The rating of a transformer, and consequently its price per kilowatt, depends on the "hottest spot" temperature after a full-load run. Considerable space is therefore devoted to methods of keeping transformers cool. It is stated that a cast-iron case will



radiate more heat than one made of boiler-plate, since the roughness increases the surface exposed to the air and to the oil in which the transformer is immersed. This is true so far as the heat conducted from the oil is concerned, but as the great bulk of the heat is carried away by convection currents in the air, it is of importance to increase these currents as much as possible, and so a rough surface may be a disadvantage.

(3) The principles that have to be taken into consideration when designing power systems are discussed. The advantages and disadvantages of the various systems are clearly stated, and will be a help to young engineers. Specimen record forms are given. These are apparently American in origin, as the lineman is warned not to "throw on the current" until he receives the signal. The consumer also gets his lamps free.

### Modern Metallurgy.

*The Metallurgy of Iron and Steel.* Based mainly on the Work and Papers of Sir Robert A. Hadfield. Compiled by the Editor of Pitman's Technical Primers. (Pitman's Technical Primer Series.) Pp. xv+122. (London: Sir I. Pitman and Sons, Ltd., 1922.) 2s. 6d. net.

THIS small volume, which is written in a very interesting manner, gives the reader a clear idea of the developments made in the metallurgy of iron and steel in recent times. The work contains seven chapters, the first of which deals with the possibilities of an approaching exhaustion of the supplies of both iron ore and coal at some future date; the author, however, points out that, as regards coal, substitution may be arranged by employing the energies of waterfalls, tides, solar radiation, plant life, winds, and finally the enormous power contained in the atoms may some day be released for useful work. Reference is made to the anxiety of the German industrial leaders and others during the Great War of 1914-1918 for the retention of the iron-fields of Northern France, thereby indicating the value that was placed on the commercial prosperity due to iron and steel manufactures.

Chapter 2 contains a brief account of the work of the pioneers in scientific metallurgy. Details are given of the Delhi Pillar, a solid column of nearly pure iron 24 ft. in length and weighing  $6\frac{1}{2}$  tons, which was erected about sixteen centuries ago. The author points out that "the finest armour and swords made during the Middle Ages cannot be excelled to-day without using special alloys." Nevertheless, these fine results were obtained empirically, and it was not until recent times that any exact knowledge of the reasons for the various methods of treatment were understood.

Tribute is paid in an appendix to the early British workers who have done so much to elucidate these matters, and in more recent years to Faraday, Heath, Percy, Bessemer, Gilchrist, Thomas, Able, Sorby, Lothian Bell, Roberts-Austen, Stead, Arnold, Hadfield, and many others.

Chapter 3 deals with iron ores and the manufacture of iron and steel, while chapter 4 is devoted to hardening, heat treatment, and microstructure. In chapter 5 alloy steels are considered, and here the work of Sir Robert Hadfield is frequently referred to, especially in connexion with nickel and manganese steels. It has been stated by the well-known German writer Mars in "Die Spezialstahle" that: "The most extensive experimental researches, which may be said to have laid the foundation of our entire knowledge of steel alloys, were carried out by Hadfield in the 'eighties of the last century." Reference is also made to the direct and indirect saving effected by alloy steels of low hysteresis discovered by Sir Robert Hadfield about twenty years ago. Mr. T. W. Yensen, of the American Westinghouse Electric Company, estimates that the total saving effected to the world by the use of this material amounts to about 340,000,000 dollars.

Fuel economy and research are dealt with in chapters 6 and 7 respectively, and the work is concluded with two appendices, one containing a list of early workers in scientific metallurgy, and the other a list of research papers and scientific addresses by Sir Robert Hadfield from 1888 to 1921.

The little book is both interesting and useful, and should certainly find a place in every metallurgical library.

W. H. M.

### The British Association Addresses of 1922.

*The Advancement of Science: 1922.* Addresses delivered at the 90th Annual Meeting of the British Association for the Advancement of Science, Hull, September 1922. Pp. 15+9+24+30+15+12+27+17+14+15+14+11+15+34. (London: John Murray, 1922.) 6s. net.

UNDER the title of "The Advancement of Science," the British Association now issues in collected form, and as a separate volume of a convenient size, even before the conclusion of the annual meeting, all the addresses, presidential and sectional, which have been delivered at that meeting. Although, perhaps, some exception might be taken to the appropriateness of the main title, as not sufficiently indicative of the actual contents of the volume, any ambiguity is removed by the subsidiary title, which

states explicitly of what these contents consist. This issue is, of course, in anticipation of the annual volume, which gives a complete record of the Association's proceedings at the particular meeting, but which cannot, in the nature of things, make its appearance until some time after its conclusion.

This practice of the Association, which is of comparatively recent origin, is altogether to be commended, and as a business proposition is to the credit of the management. Experience has shown that it meets a public demand. Members who attend a meeting are ready to purchase, at the comparatively low price of issue, a collected edition of the addresses, as are those who are unable to be present. The fact is significant of the increasing appreciation in which these addresses are held by the public. In the early days of the Association it was not considered obligatory on the part of a president of a section to prepare a special address by way of opening its proceedings, and he occasionally contented himself with a few general remarks before calling upon a member charged with the preparation of a report on the progress of the particular department of science with which the section concerned itself, either to read the report or to give an abstract of its contents. Failing the report he would call upon a member to present the first communication on the list, and in some such manner the business of the section would be begun. Gradually the present custom has been evolved, and the presidential addresses have become a valuable and most important feature of the work of the section—some people, indeed, would say the most valuable and important.

The presidents of sections nowadays are invariably representative men or women recognised authorities on the special subjects with which the section deals. They are usually active workers in the development of knowledge on these subjects—persons with experience of research and of matured judgment, with a message of advice, counsel, or warning to communicate, or they may even promulgate a wholly new departure in scientific thought. Hence the eagerness and expectancy with which these utterances are awaited, not only by the professional members of the section but also by such portion of the general public as shows its interest in the progress of science either by attending the meetings of the Association, or following its proceedings in the press. The appreciation in which these sectional addresses are now held is further shown by the measures which the executive have been required to take in deference to public demand. Formerly the addresses were all given on the same day, and as a rule at the same hour, and they initiated the work of their respective sections. Nowadays special arrangements are made, so that members may have an opportunity

of hearing as many as possible during the week over which the meeting extends. Their publication in collected form during the week of the meeting will be of service to those who for various reasons are unable to take advantage of such opportunity, and will be welcomed by others who may wish to study them in detail and at leisure. There are, of course, some, and they are particularly common among those of the student habit, upon whom the printed word makes a more effective impression than that spoken.

It is unnecessary on the present occasion to say anything at length concerning the contents of the volume before us. Any detailed examination or criticism is the more uncalled for, as most of the addresses themselves, slightly abridged in some cases, have been, or are being, reproduced in these columns. It is sufficient to say that the 1922 book worthily sustains the reputation which British Association addresses now enjoy, as well-written, scholarly productions, pregnant with thought, replete with fact and suggestion, stimulating and full of interest and inspiration to the contemplative kind. In an age which is pre-eminently scientific these books deserve the widest possible circulation, and, in the interests of knowledge it is to be hoped that they will attain it.

### Our Bookshelf.

*Der fossile Mensch: Grundzüge einer Paläanthropologie.*  
Von Prof. Dr. E. Werth. Erster Teil. Pp. iv + 336.  
(Berlin: Gebrüder Borntraeger, 1921.) 20s.

ENGLISH students who wish to know what their German colleagues think of recent discoveries of fossil man will be somewhat disappointed when they consult this work. Its author, Prof. Werth, who has published several books on the Ice-age and allied geological subjects, has either never heard of the fossil remains discovered at Piltdown and fully described by Dr. Smith Woodward, or refuses to believe in their authenticity; at least no mention is made of them. Nor is any allusion made to the remains found at Boskop, South Africa, the fossil skull found at Talgai, Queensland, nor those found by Prof. Eugene Dubois at Wadjak-Java. On the other hand, full and welcome accounts are given of two important finds made in Germany during war-time. One of these was made at Ehringsdorf, near Weimar, where two fossil lower jaws were found. These are attributed—and rightly so—to Neanderthal man, whose distribution is thus carried beyond the watershed of the Rhine. The other discovery, which was made at Obercassel, near Bonn, has revealed the remains of a man and of a woman belonging to the last phase of the Ice-age, and regarded by their discoverers as members of the so-called Cromagnon race. The skull of the man serves very well as the prototype of many a specimen found in neolithic graves in Scandinavia and Britain, but has such outstanding cheek-bones, zygomatic arches and angles of the jaw (or jowls) as have never been seen in

European skulls hitherto. The width of the face in front of the ears is 153 mm., at the angles of the lower jaw 127 mm., betokening an extraordinary development of the masseter muscles. Notwithstanding these features, the skull is that of a strong, handsome, and big-headed man.

The opening chapters of this work are devoted to an orthodox and clearly worded description of Europe in the Ice-age. In dealing with human remains, Prof. Werth depends very largely on the methods and conclusions of Schwalbe and of Klaatsch. Prof. Werth accepts Schwalbe's verdict that Neanderthal man was not the precursor of modern man, but was extinguished by the arrival of the Aurignacian race in Europe. He is inclined to think the Cromagnon type represents a later invader of Europe, and accepts this type as the precursor of the long-headed modern Europeans—both of the dark Mediterranean and of the fair Scandinavian type. The work, of which this is Part 1, is well illustrated.

*Studien an Infusorien über Flinkerbewegung, Lokomotion und Reizbeantwortung.* Von Dr. Friedrich Alverdes. (Arbeiten aus dem Gebeit der experimentellen Biologie, Heft 3.) Pp. iv+130. (Berlin: Gebrüder Borntraeger, 1922.) 12s.

THE little book under notice is a record of careful work, chiefly upon the behaviour of *Paramecium caudatum*, although the three other species of *Paramecium*, *Stentor polymorphus*, and other Infusoria, figure in some of the experiments. The author has made an especially detailed study of the movements of *Paramecium* and of the action of its cilia, and his observations on its morphology are not without interest. He discusses the behaviour of these organisms when operated upon, and also their reactions to narcotics and other chemical stimuli and to the galvanic current.

While the author admits the merit of Jennings's work in this field of study, he is, nevertheless, frequently in conflict with this worker, both in his observations of behaviour and his interpretations of them; but it is not certain that he thoroughly grasps Jennings's views, and it is noteworthy that the latest edition of "The Behaviour of the Lower Organisms" (Columbia Univ. Press, 1915) is not in Dr. Alverdes's Bibliography. Dr. Alverdes ranges himself energetically against all those who see in the Infusoria nothing but "small automata," and vigorously opposes the mechanistic interpretation of their behaviour. Like Jennings, he denies that the local action theory of tropisms can explain completely the behaviour of these organisms. He would substitute for it another view to which his researches have led him, but it is impossible, in the short space at our disposal, adequately to present this view or to criticise it. Undoubtedly Dr. Alverdes's work is careful, and is marked throughout by independence of mind. He insists, with admirable emphasis, that little progress can come from the study of the Protista in unusual media or in media which are artificially prepared upon physico-chemical principles alone. The same argument might be applied with profit to all other work on the Protista.

In spite of a rather difficult and discursive style, the book should not be neglected by those who are interested in the problems with which it deals.

*An Introduction to Electrodynamics: From the Standpoint of the Electron Theory.* By Prof. Leigh Page. Pp. vi+134. (Boston and London: Ginn and Co., 1922.) 10s. net.

HITHERTO the mathematical equations of electro-dynamics have been based on the experimental conclusions of Coulomb, Ampère, and Faraday. Even books which discuss relativity go no further than showing that these equations are co-variant for the Lorentz-Einstein transformation. In Prof. Page's book, however, the equations are derived directly from the principle of relativity. The mathematician will appreciate this procedure as it is more logical, but we think that the average reader will find the older methods more convincing. The units chosen are those advocated by Heaviside and Lorentz. The value of the charge at any point is equal to the number of tubes of force diverging from the point; all matter is assumed to be made up of positive and negative electrons; electromagnetic force is defined in terms of the electric intensity of lines of force, and gravitational attraction between two electrons is supposed to be negligibly small. The electrons carrying a current are all of the same sign, and their masses are positive. Hence the "mass of the current" is greater than the sum of the masses of the individual electrons composing it.

The author's methods of calculating the radiation from electrons are to be commended, and he also gives a good account of Laue's theory of the diffraction of X-rays. The formulae deduced for specific inductive capacity, magnetic permeability, and metallic conductivity agree fairly well with experimental results. The theories of Faraday's experiment showing the rotation of the plane of polarisation of light by a magnetic field and of the Zeeman effect are given briefly, but in a convincing way. We can commend this book to the electrician who has an advanced knowledge of mathematics and is interested in the latest theories.

*Handbuch der biologischen Arbeitsmethoden.* Herausgegeben von Prof. Dr. E. Abderhalden. Lieferung 55. Abt. V: *Methoden zum Studium der Funktionen der einzelnen Organe des tierischen Organismus.* Teil 6, Heft 3. *Sinnesorgane: Lichtsinn und Auge.* Pp. 365-462. (Berlin und Wien: Urban und Schwarzenberg, 1922.) 117 marks.

THIS portion of the work, Abderhalden's "Handbuch," is the direct continuation of parts 3 and 41 which dealt with the biophysical methods used in investigating the living eye and its sensitivity to light. The first section, by Dr. Vogt of Basel, is devoted to the method of examining the eye with light from which the red rays have been absorbed by passage through a concentrated solution of copper sulphate and a weak solution of erioviridine. With such light, investigations of the yellow spot are rendered much easier and more accurate. The second section of 76 pages, by Dr. Basler of Tübingen, deals with methods which in the main are intended to investigate the functions of the retina and its various parts. Sharpness of vision, irradiation, and detection of movement are some of the subjects dealt with. The concluding section, by Dr. Struycken of Breda, describes the photographic method he uses for studying the

movement of the eyeball from side to side. The treatment is in general more wordy than is desirable, but the work brings together in an accessible form a large amount of information hitherto buried in memoirs, published in most cases abroad.

*Our Homeland Prehistoric Antiquities, and How to Study Them.* By W. G. Clarke. (The Homeland Pocket Books, No. 13.) Pp. 139 + plates. (London: The Homeland Association, Ltd., 37-38 Maiden Lane, 1922.) 4s. 6d. net.

MR. CLARKE'S little handbook on the prehistoric antiquities of Britain covers the whole subject from Eoliths to the Iron Age. One of its main objects, however, is to help the novice to discriminate between stones shaped by natural forces and those chipped by man. In so far as this is possible by means of the printed word, Mr. Clarke is a good guide, while his practical hints on where and how to look for implements will be of great assistance to those taking up field work for the first time. As it covers so wide a field the treatment is necessarily summary, while in dealing with controversial points conclusions are stated dogmatically, which, in a more ambitious work, would require extended discussion. For this reason, Mr. Clarke must be forgiven some over-hasty statements. The amount of information which he has succeeded in condensing into so small a compass is remarkable. There are few subjects connected with prehistoric peoples of these islands, whether it be their implements, their dwellings, or their modes of life, about which the beginner will not find sufficient information here to open a path to further study, and this, in a book of this type, is in itself a great achievement.

*Homo (Os Modernos Estudos sobre a Origem do Homem).* By Prof. A. A. Mendes Corrêa. Pp. 318. (Lisboa; Porto; Coimbra: Lumen Empresa Internacional Editora, 1921.) n.p.

IN this country the work of Portuguese anthropologists is not too widely known; yet it is deserving of more attention than it receives. In prehistoric archaeology and somatology, investigations are being carried on which, if not considerable in bulk, are of some importance for students of European ethnology. We therefore welcome the opportunity of directing attention to this book by Prof. Mendes Corrêa, in which the most recent discoveries and hypotheses relating to the origin and descent of man are critically discussed. Each chapter deals with some one aspect of the problem, beginning with "the animal origin of man," and passing on to "evolution," the evidence of palæontology, *Pithecanthropus erectus*, the skeletal remains of prehistoric man, anthropogenesis, and a detailed exposition of the neo-monogenistic point of view. It is interesting to note that the author, in the case of the Trinil and Pittdown remains, adheres to the view in the former that the fragment of skull is simian and the femur human, and in the latter that the cranium is human and the jaw simian. A final chapter summarises the author's views, published elsewhere, on the influence of environment in the formation of races, and reviews the problems which await elucidation by further discoveries.

*Sound: An Elementary Text-book for Schools and Colleges.* By Dr. J. W. Capstick. (Cambridge Physical Series.) Second edition. Pp. viii + 303. (Cambridge: At the University Press, 1922.) 7s. 6d.

IN the second edition of Dr. Capstick's text-book of sound, a chapter has been added giving an outline of some of the more important applications of acoustics to military operations during the war of 1914-18. The author is not very successful in conveying in the fewest possible words a clear idea of the apparatus employed, and his descriptions would have been improved by the use of diagrams. It must, however, be pointed out that some of the diagrams in the earlier chapters are by no means perfect. In Fig. 95 the pendulum would quickly damage the mercury cup, and it is doubtful whether the Bell telephone in Fig. 99 would have been recognised by its inventor. The granular transmitter, inadequately illustrated on page 222, does not serve in this primitive form as a suitable microphone for use in a hydrophone. The author has obviously made a slip when he says that in signalling under water the sound is received by a submerged microphone similar to a receiving telephone. In spite of some defects the volume will serve a useful purpose as a class-book for schools.

*Sewerage and Sewage Disposal: A Textbook.* By L. Metcalf and H. P. Eddy. Pp. xiv + 598. (New York and London: McGraw-Hill Book Co., Inc., 1922.) 25s. net.

THE volume before us is the work of the authors of a three-volume treatise on "American Sewerage Practice," and is the result of a demand for a shorter book suitable for students who have not a great deal of time to devote to this subject. The early sections of the book deal with the main outlines of the problem of sewerage—the quantity of sewage to be expected, storm water, hydraulics, etc. Methods of surveying and excavating are then treated, together with the details of carrying out the work. The later sections deal with the chemical and biological characteristics of sewage and with disposal methods. There is a chapter on cost-estimating at the end of the volume. The authors are engineers whose practice brings them into intimate contact with the matters treated; this is reflected in their book, which cannot fail to be of service to students, British as well as American. The volume is profusely illustrated and is thoroughly up-to-date. There are some useful graphs, among which we note one giving the discharge of egg-shaped sewers running full depth, which is based on Kutter's formula.

*Manuel de tournage du bois.* Par Hippolyte Gaschet. (Bibliothèque Professionnelle.) Pp. 248. (Paris: J.-B. Baillière et Fils, 1922.) 10 francs net.

A VERY good account of the tools used and the methods employed in wood-turning is given in this little volume, which will be found to be supplementary, in some respects, to English works on the same subject. The language difficulty will probably prevent the book from reaching the hands of many young workers in this country, but manual instructors should find it useful, especially in view of the graduated series of exercises which is included at the end of the volume.

## Letters to the Editor.

[The Editor does not hold himself responsible for opinions expressed by his correspondents. Neither can he undertake to return, or to correspond with the writers of, rejected manuscripts intended for this or any other part of NATURE. No notice is taken of anonymous communications.]

## Periodicities.

THE recent paper by Sir William Beveridge on "Wheat Prices and Rainfall" (Journal of the Royal Statistical Society, vol. 85, pp. 412-478, 1922) raises a rather important question of principle which is involved not only in discussions over the existence of periodicities, but also over relationships between different variables.

Before Schuster's papers on the periodogram it was customary for a period to be accepted as real provided that it had an amplitude comparable with that of the original figures under analysis; and he revolutionised the treatment of the subject by showing that if the squares of the intensities of the various periodic terms are plotted in a periodogram, and if the data are those of an entirely chance distribution, then the average value of an ordinate being  $a$ , the probability that a particular ordinate will equal or exceed  $ka$  is  $e^{-k}$ . Sir William Beveridge is accordingly perfectly justified in taking Schuster's sunspot period of 11.125 years, or Brückner's 34.8 year period, and deciding that these periods probably occur in his wheat prices if the corresponding intensities are three or four times the average. But he, like many other investigators, goes a stage further, and after picking out the largest from a large number of intensities he applies the same criterion as if no selection had occurred. It is, however, clear that if we have a hundred intensities the average of which,  $a$ , is derived from a number of random figures, then the probable value of the largest of these chance intensities will not be  $a$  but will be considerably greater, and it is only when the largest amplitude actually derived materially exceeds the theoretical chance value thus obtained that reality can be inferred.

Taking the periodicities of wheat prices on pp. 457-459 between 5 years and 40 years,<sup>1</sup> I estimate that the "width of a line" ranges from 0.1 year for a 5 years' period, through 0.5 at 12 years to 4 years at 33 years; and accordingly that the number of independent periods between 5 years and 40 is in this case about 51. The value of  $a$ , the average intensity, being 5.898, it is easily seen that the chance of all the 51 random intensities being less than  $3a$  is  $(1 - e^{-3})^{51}$ , or 0.074, so that the chance of at least one intensity greater than  $3a$  is 0.926, not  $e^{-3}$  or 0.050, as is habitually assumed. Instead of the chance of an occurrence of  $3a$  "making a *prima facie* case for enquiry" (p. 424), the odds are 12 to 1 in favour of its production by mere chance. The chance of at least two intensities above  $3a$  is 0.728, of three it is 0.470, of four 0.248, of five 0.109, of six 0.0403, of seven 0.0127, of nine 0.00085, and of eleven 0.0003.

Thus it is not until six intensities over  $3a$  are found that the chance of production by pure luck is less than 1 in 20. It is also easily found that if the chance of all the 51 intensities being less than  $na$  is to be 19/20,  $n$  is 6.9; i.e. the greatest intensity for wheat price fluctuations must be 41, not 18, before the probability of its being due to luck is reduced to 1/20;

<sup>1</sup> Sir William Beveridge points out on pp. 423-424 that amplitudes for periods of less than 5 years are inevitably diminished, while those above 31 are diminished by the process employed for eliminating secular trend; I calculate that the intensity at 35 years should be multiplied by  $(0.97)^{-35}$  or 1.3, and that at 54 by 3.8.

and if the likelihood is to be 1/100 we must have  $n = 8.5$ , the corresponding wheat-price intensity being 50. Of intensities greater than 41 Sir William Beveridge found four, and greater than 50 only two.

At first sight it might seem that the agreement between Sir William Beveridge's forecasted synthesis rainfall curve and the actual rainfall was too great to be explained by a few harmonic terms; but the correlation co-efficient of 0.38 (see p. 475) indicates that while 0.38 of the rainfall variations are accounted for, only  $(0.38)^2$ , or about a seventh, of the independent factors which control these variations have been ascertained.

As pointed out in a paper "On the Criterion for the Reality of Relationships or Periodicities," in the Indian Meteorological Memoirs (vol. 21, No. 9, 1914), the same principle is valid when discussing relationships. If we are examining the effect of rainfall on temperature and ascertain that the correlation co-efficient between the rainfall and temperature of the same month in a particular English county is four times the probable error, we may infer that the effect is highly probable. But if we work out the co-efficients of that temperature with a hundred factors taken at random, e.g. with the monthly rainfall of Tashkend 5.8 years previously, and pick out the largest co-efficient, it would be wrong to compare it with the average co-efficient produced by mere chance; as shown in the paper referred to, the probable value of the largest of 100 co-efficients is 4.01 times as great as the probable value of one taken at random.

GILBERT T. WALKER.  
Meteorological Office, Simla, August 24.

DR. WALKER'S note contains, I think, a valid and valuable criticism of the procedure commonly adopted hitherto in comparing individual intensities with the average intensity in harmonic analysis. It would lead me now to modify in several ways my general discussion of the "test of intensity" (pp. 422-424 of my paper in the Journal of the Royal Statistical Society. I was particularly careful, however, in that paper to avoid laying stress on intensity as such. The net result of Dr. Walker's calculations is not to weaken but to confirm my main thesis: that a number of real periodicities exist in European wheat prices from 1550 to 1850.

According to these calculations, the chance of my getting by pure luck between five and forty years one intensity as great as  $3a$  is 0.926, but the chance of my getting seven such intensities is 0.0127, and that of getting eleven is 0.0003. Actually I have, between five and forty years, fifteen intensities above  $3a$  (=17.69); the odds are therefore 80 to 1 that at least nine of these intensities, and 33,000 to 1 that at least five of them, are not due to luck. Obviously every such intensity does, in the circumstances, present a *prima facie* case for further inquiry, the object of the inquiry being to determine which of the 15 intensities have the strongest probabilities of being due to real periods.

In that inquiry the actual height of the intensity in any case (the "test of intensity") is only one and not necessarily the most important point for consideration. As Dr. Walker shows, an intensity in my periodogram of nearly seven times the average might well be due to pure luck (the odds being only 20 to 1 against it). On the other hand, a much lower intensity might represent a true and perfectly regular but weak periodicity, just as a quite small correlation co-efficient may prove a real though weak connexion, if the number of cases compared is very large. Indication of the same period in each half of a sequence when analysed separately (the "test of

continuity") and in independent sequences (the "test of agreement with other records") are often more important criteria of reality than is the height of the intensity itself. The former test, at least, should never be neglected; it has led me to relegate to my fourth class as merely "possible," several periods, such as those near 11, 17, and 24 years, indicated by high intensities in the whole sequence, but failing in either the first or the second half.

Ultimately, of my fifteen intensities between 5 and 40 years, I have treated only nine (at 5:100, 5:671, 5:960, 8:050, 9:750, 12:840, 15:225, 19:900, and 35:500 years respectively) as certainly or probably due to real periodicities, because they show in all cases perfect or fair continuity and in most an agreement with other records. The smallest of these fifteen intensities (21:72 at 7:417 years) in fact equals not  $3\alpha$  but  $3\cdot683\alpha$ . If with this revised figure, the probabilities are calculated in the way suggested by Dr. Walker, the odds that at least nine of the fifteen intensities are not due to luck work out at more than 2000 to 1, while the odds in favour of seven at least are 14,000 to 1.

This remarkable result, which seems to establish beyond all reasonable doubt the reign of periodicities in wheat prices, is not affected by the fact that of the fifteen intensities only four are so high that any one of the four, if it occurred alone and had to be judged by height alone, would have odds of more than 20 to 1 in its favour. Each intensity does not occur alone. Every period, moreover, to which I attach importance rests on more evidence than mere height in my periodogram.

With reference to the last paragraph but one of Dr. Walker's note, on the relation of my synthetic curve and the rainfall, I should like to emphasise the point made in my paper (pp. 449-450) that the synthetic curve as now drawn represents only a first approximation of the roughest possible character; the correlation co-efficient of 0.38 between it and the rainfall from 1850 to 1921 is sufficient to demonstrate some connexion between the wheat price cycles and the rainfall, but is in no sense to be treated as a measure of the degree of connexion. In constructing the synthetic curve, for instance, the periodicities have all been treated as of equal importance; inspection shows that weighting according to the intensities would almost certainly give a better fit and so a higher co-efficient of correlation. In many other ways a more accurate determination of the cycles is required. How high a correlation might ultimately be obtained as the result of this, it is impossible now to say, but it might easily prove to be very high indeed. Unfortunately, I have no resources for carrying my own investigations further for the present; I can only hope that others may be better placed.

W. H. BEVERIDGE.

#### One Possible Cause for Atmospheric Electric Phenomena.—A Query.

MAY I ask Sir Arthur Schuster or Dr. Chree or some other authority whether there is any serious objection to an idea like the following:

The sun being radio-active emits not only gamma rays, which ionise the atmosphere, but also alpha and beta particles. The alpha particles will be stopped by the upper layers of atmosphere, charging them positively, while the beta particles will be more penetrating, and might even reach the ground, charging it negatively; though I admit that thirdly, charges of mercury is a serious obstruction. But, as Arrhenius showed, the beta particles would be

magnetically inveigled towards the poles, where they might descend with down currents: whereas the alpha particles—most numerous near the tropics—would be sustained by up currents; and thereafter the separated charges would reunite with familiar dielectric disruption.

OLIVER LODGE.

Normanton, Lake, Salisbury, Sept. 29.

#### School Instruction in Botany.

IN the article on "School Instruction in Botany" in NATURE of September 2, p. 329, the report on the botany gardens of the James Allen's Girls' School, recently published by the Board of Education, was reviewed. As I am not only the author of the report but also the initiator and organiser of the botany gardens at Dulwich, I shall be glad if space can be afforded me to reply to the following comment at the end of the article: "No mention is made in the Report of the utilisation of the botany gardens for the observation of animal life." The omission is due to the fact that the report was written in 1915 (see prefatory note) when some of the "gardens," which are now of great help in studying animal life, were in an undeveloped condition.

For example, in 1915 the oak trees in the new wood were only from three to four years old and looked somewhat like sticks, as shown in Plate 10. Since 1915 the trees have grown so much that blackbirds, hedge sparrows, and a thrush have built nests, laid their eggs and in all cases but one reared their young in our wood. Advantage of this has been taken and many girls have visited the nests. During outdoor lessons, girls have learned to recognise birds which frequent the school garden, and have become familiar with their calls and songs.

In the spring term the awakening of the numerous frogs which hibernate in the school pond is eagerly awaited. For a short period the pond is densely populated by hundreds of croaking frogs. Later, the development of the tadpoles through all the stages is watched with the keenest interest by girls of all ages. Observation of animal life in the pond includes the study of the life-histories of china mark moths, dragon flies, newts, great water beetles, water boatmen, and water snails. On one occasion last term many girls watched the various stages in the emergence of a china mark moth from its chrysalis.

In these and in other ways the botany gardens at the James Allen's Girls' School are utilised for the observation of animal life.

LILIAN J. CLARKE.

James Allen's Girls' School,

East Dulwich Grove, S.E.22, September 28.

#### Transcription of Russian Names.

IN his further letter (NATURE, July 15, p. 78) Lord Gleichen refers to the Royal Geographical Society's System (II.) for the transcription of foreign alphabets into English. A copy of this system has just reached us and impresses us with its completeness and utility, especially for rendering place-names into English.

With regard to the transcription of Russian names we agree with Lord Gleichen that French, German, and hybrid transcriptions are unsatisfactory, but we would advocate, with Prof. Brauner, an international system, and for this purpose the Czech transcriptions have much to recommend them.

In the first place, the Serbian alphabet contains fewer letters than the Russian, and is thus inadequate to allow of accurate transcription from Russian by

the Serbo-Croatian rules. Czech transcription has the advantage of being complete.

The following examples may serve to make this clear. Russian *a* has only one sound, as in "master." It has the same sound in Czech, but the English *a* has several sounds. If *ж* is rendered by *j* it is liable to mispronunciation; if transcribed to the Czech *ž* this liability does not arise. Russian *y* is always pronounced like the Czech *u* (like *oo* in the English word "hook"). Russian *x* can be correctly rendered by the Czech *ch*.

"Hard mute" and "soft mute" (*ь* and *Ь*) can only be transcribed into Czech, using the hook *ʹ* after the consonant. Russian *ы* has no other European sound except the Czech *y*. The different pronunciation of the Russian *e*, *ѐ*, *ё* cannot be easily expressed in English, but this becomes easy by using the Czech *ě* for the first two, especially the second.

It may be pointed out that the Czech transcription is already employed in the International Catalogue of Scientific Literature, and for some years German journals (e.g. *Zeitschr. f. anorg. Chem.*) have employed letters with diacritical marks in their transcription of Russian names (e.g. "Zemczuznyj," which in Czech is "Zemčuzný").

The objection, urged by Lord Gleichen, to the use of diacritical marks exists, but is relatively small. Most scientific journals already have such type, which is indeed necessary if Czech names are to be printed correctly. Newspapers naturally lag behind such a journal as NATURE in matters of this kind, but in time these too will doubtless find it necessary to have letters with diacritical marks in their founts.

Lord Gleichen also asks how many English people can correctly pronounce Czech letters like *č*. It is regrettable, but nevertheless true, that the correct pronunciation of foreign words is not a great characteristic of the British people, but it is as easy to learn how to pronounce Czech words as it is those of other languages. The example which was chosen by Lord Gleichen is poor, because the sound "č" exactly corresponds to the English sound "ch" (e.g. "church").

J. G. F. DRUCE.

Bled, Carniola, Jougo-Slavia.

A. GLAZUNOV  
(formerly docent at  
Petrograd Polytechnic).

Prague, Král. Vinohrady, Wenzigova 21,  
Czecho-Slovakia,  
August 5.

### Colour Vision and Syntony.

IN NATURE of September 9, p. 357, Prof. E. H. Barton has shown how a syntonic hypothesis of colour vision may be made to represent the trichromatic theory of colour vision. There are numerous facts which are quite inconsistent with any form of the trichromatic theory. These are given in detail in my recent book on the "Physiology of Vision" and subsequent papers, and no attempt has been made to answer any one of them. Every fact points to the visual purple being the visual substance which, sensitising the liquid surrounding the cones, sets up a visual impulse in the cones when decomposed by light. Houstoun's explanation of the physical processes is in complete accordance with the facts, and so far as I am aware no valid objection to it has been found.

Any theory of vision must explain the movement of the positive after-image in the retina. For example,

if the positive after-image of a small white triangle on black velvet be obtained with one eye, on moving the head with a jerk, both eyes being covered, an irregular white figure will be seen some little distance away from the clearly cut black triangle, the negative after-image in the original position which is seen when a small amount of light is allowed to enter the eye through the lids. Another very simple method of seeing this movement of the positive after-image is to look at three windows on awaking, which are separated by walls; on closing and covering the eyes, well defined positive after-images of the windows separated by black spaces corresponding to the walls are seen. On covering the eyes and moving the head from side to side the after-images all blend into one, the black spaces being obliterated.

Let us compare the model given by Prof. Barton with the known facts of vision. For any particular light the three vibrators acting together should give the luminosity curve for that light. Barton has placed the red vibrator at about  $\lambda 760 \mu\mu$ ; here the red has very little luminosity, whereas a driver of the length of the vibrator at this point will produce most effect. Again, drivers corresponding to the infra-red or ultra-violet will affect the red or violet vibrators respectively, whereas these regions are invisible.

When we come to colour blindness the trichromatic theory fails completely. How on this theory can the fact that more than fifty per cent. of dangerously colour blind people can pass the wool test be explained? The fact that a dichromic may have a luminosity curve similar to the normal, that the trichromic have only three colour sensations and designate the yellow region as red-green, and the other degrees of colour and light perception, has to be explained.

F. W. EDRIDGE-GREEN.

London, September 19.

### The Green Ray at Sunset and Sunrise.

THE review by Sir Arthur Schuster of Mulder's book on the green ray or green flash at rising and setting of the sun, in NATURE of September 16, p. 370, leads me to make the following remarks:

There are, in reality, two distinct phenomena which go under the name of the green flash. The first, probably the one most usually seen and the only one to which the epithet properly applies, is certainly an after-image in an eye fatigued by the red light of the sun. I have seen it many times, only at sunset, and in many localities—on the Red Sea (twice in one evening owing to the sun being occluded by a narrow bank of cloud prior to its actual setting), in Devonshire, and even in London as the sun set behind University College Hospital.

This phenomenon can be reproduced quite easily in the laboratory by means of an artificial red sun, as I demonstrated a few years ago at a meeting of the Physical Society of London.

The second phenomenon, which I have never been successful in seeing and of which I can say little, is evidently due to atmospheric dispersion; and, from the published accounts, I should judge that it should be called the blue sun or multicoloured sun or spectrum flash. It would seem to be much more rare, as I gather from Sir Arthur Schuster's previously made descriptions that it requires rather special conditions.

If this subject should get into elementary textbooks, as recommended, at least let the account of it be complete.

ALFRED W. PORTER.

University College,  
London.

### Photography of Bullets in Flight.

By PHILIP P. QUAYLE, Assistant Physicist, National Bureau of Standards, U.S.A.

INSTANTANEOUS photography by means of an electric spark provides the investigator of high-speed phenomena with a most valuable source of data. Such photographs are of the shadow variety, the bullet shadow being projected upon a photographic plate by a spark of great intensity and short duration. If the bullet is moving with a speed equal to or greater than that of sound, it propagates from both its nose and base

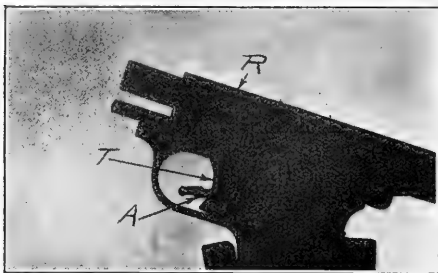

FIG. 1.—Automatic pistol in position of extreme recoil, empty cartridge case not yet ejected.

T=trigger; R=receiver; A=arm operating trigger.

a compressional wave. Light from the photographing spark in passing through the denser atmosphere of the compressional wave is refracted as by a lens, so that the wave front is also projected upon the photographic plate with the bullet. The method lends itself readily to the investigation of a projectile's stability at various points along its trajectory and to many allied problems of exterior ballistics. Instructive photographs of the recoil and shell ejection of automatic rifles, pistols, and machine guns may also be obtained in this manner.

Among the most important of the early contributions in this field of research are the admirable spark photographs by Prof. C. V. Boys (*NATURE*, Vol. 47, pp. 415 and 440), who greatly simplified the elaborate apparatus of Prof. E. Mach. In Prof. Boys's apparatus the bullet was employed to close the spark circuit, and this method has been followed in experiments which have been carried on since that time, so far as the present writer is aware.

In the method described in this article the setting-off or triggering of the electric spark by which the photographs are taken is controlled by the compressional wave produced by the flight of the bullet, so that no wires or other portions of the apparatus need appear on the plates. Since the sound wave is used to trigger the photographing spark, the position of the rifle firing the bullet may be varied at will without affecting the functioning of the apparatus, the only requirement being that the bullet shall have a speed greater than that of sound. When the speed of the bullet is less than that of sound the muzzle blast may be used to trigger the spark. In such cases the rifle must not be moved.

In Prof. Boys's type of apparatus the photographing spark is set off by the closing of a secondary gap by the bullet itself. In the present apparatus a much more powerful spark may be used than would otherwise be

possible, because the potential available for the photographing spark is not limited by the dielectric strength of some trigger gap of fixed and small dimensions.

The regulation of the potential of the spark is essential, however, since great irregularities in time occur when the apparatus is not operated at the same potential, the spark occurring earlier or later than the transit of the bullet across the plate. This, of course, precludes satisfactory records when working with modern high-speed bullets. When the proper potential has been attained a signal light is automatically turned on.

No lens system is employed in the apparatus. An arrangement which has been found very satisfactory places all of the photographic apparatus, except the trigger, inside a small light-tight house.

The trigger itself is located outside the house and near the trajectory. This trigger is an interrupter of the type used by the French in connexion with the Joly chronograph. The use of this instrument and the type of springs used in the photographing-spark-switch were suggested by Dr. D. C. Miller, of the Case School of Applied Science, where the apparatus was developed. The trigger consists of a metal diaphragm about 2 inches in diameter enclosed in a circular metal box. The diaphragm forms one side of an air-tight enclosure, and on the inside face of the diaphragm is attached a circuit-breaking mechanism. This circuit-breaker functions when the crack wave emanating from the bullet strikes the diaphragm, which in turn throws back a small hammer, thus interrupting the circuit and



FIG. 2.—Automatic pistol; empty cartridge case just emerging from the receiver.

tripping the photographing-spark-switch, with which it is connected in series.

The essential parts of the photographic apparatus consist of a large Leyden jar battery charged by a static machine which is motor driven, the control switch for the motor being mounted on the table with the rifle. A potential regulator which is connected across the battery functions when the proper potential has been reached, and trips a switch which disconnects the battery from the charging machine and short-circuits the terminals of the latter. The switch when tripped turns on a signal light located outside the apparatus house as a signal to the rifle operator to fire.

When operating the apparatus the general sequence of events is as follows:



The photographing-spark-switch and battery-switch inside the apparatus house are set, the lights turned out, and the slide of the plateholder drawn. The operator then leaves the apparatus house by means of a light-tight passage and starts the static-machine motor by closing the table switch. He then makes any necessary



FIG. 3.—Automatic pistol; empty cartridge case ejected from receiver.

correction to the aiming and fires when the signal light appears. The bullet leaves the rifle and on its way to the apparatus house passes the trigger upon the diaphragm of which the sound wave impinges. This immediately trips the photographing-spark-switch and it starts to close the trigger gap in the spark circuit. The bullet continues on past the trigger, entering the apparatus house through a sheet of thin paper, used to shut out the light, and arrives in front of the photographic plate, upon which it is then projected by the photographing spark. The motor switch is then opened and the slide replaced in the plateholder, which may then be taken to the dark room and developed.

In case the speed of the bullets to be photographed is not known, a piece of paper or wire screen is placed in the path of the bullet in front of the photographic plate, and if a puncture in the screen is shown when the plate is developed, evidently the bullet had gone past the plate before the spark occurred. The trigger must then be moved back from the plate and the process repeated. Continuing in this manner the position of the bullet when the spark occurs will soon be bracketed within limits sufficiently small, so that an observer inside the apparatus house may see the bullet as the spark illuminates it. Visual adjustment only is then used until most of the bullets are seen in the desired locality when the spark occurs.

The apparatus is provided with two light gaps, one horizontal and the other vertical. This arrangement facilitates the taking of two photographs of the same bullet, a plan and elevation view. This is particularly useful in investigating a projectile of an unstable character having a tendency to tumble, since from the two views its actual position in space may be constructed.

The two coaxial waves which the bullet propagates

from its nose and base appear on the photograph (Fig. 4) to have different slopes. This arises from the projection, for while the axis of the wave is parallel to the photographic plate, and therefore projected in proportion to its length, the radius of the projected wave is somewhat inclined to the plate and causes the distortion. The true angle of the conical sound wave in air may, however, be readily computed, from which the speed of the bullet producing the wave may be determined.<sup>1</sup>

In obtaining the photographs of the Colt automatic 25-calibre pistol, reproduced in Figs. 1, 2, and 3, the interrupter trigger was removed from the circuit and a timing device substituted, which consists of two electromagnets connected in series and adjustable in height, their function being to drop two steel balls at the same time when the key opening their circuit was depressed. One of these balls fell on a lever which pulled the trigger T of the automatic pistol by exerting tension on the arm A (see Fig. 1). The other ball, released from a greater height at the same time as the first, impinged on a device setting off the photographing spark. By this means any reasonable lag or lead in the firing of the pistol with respect to the occurrence of the photographing spark could be obtained. The firing apparatus is obviously not a precision instrument and could, of course, be replaced by an accurate timing device should the investigator require information of such a character.

The turbulent gases of the propelling charge are clearly shown in Figs. 1, 2, and 3. All these photographs of the automatic pistol represent a stage in the recoil relatively long after the ejection of the bullet from the muzzle, since it will be seen that the receiver R has reached the position of extreme recoil and the empty cartridge case is being ejected in Figs. 2 and 3.

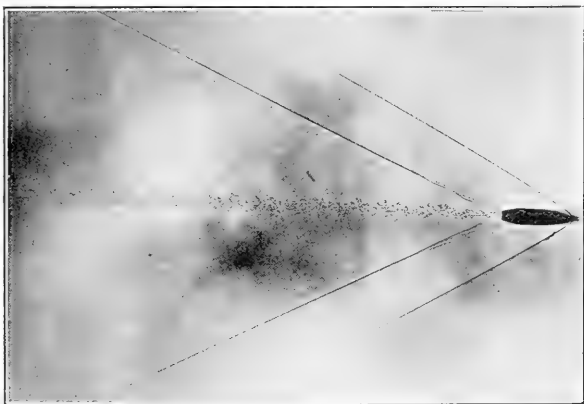

FIG. 4.—30 Calibre boat-tailed bullet, approximate speed 2500 feet per second.

If the height of the ball which triggers the spark is changed progressively by some small known amount, a series of photographs of such an automatic pistol at slightly different calculable time intervals could be secured. From the data obtainable from such photographs a pressure time curve could be computed.

<sup>1</sup> Journal of the Franklin Institute, May 1922.

The Study of Man.<sup>1</sup>

By H. J. E. PEAKE.

A CHANGE has been creeping over our science. Twelve years ago anthropologists were devoting their energies to the tracing out of the evolution of customs and material culture, assuming that, where similarities were found in different parts of the world, they were due to independent origins. It was assumed that the workings of the human mind were everywhere similar, and that, given similar conditions, similar customs would originate. The evolution of civilisation was looked upon as a single line of advance, conditioned by the unalterable nature of the human mind, and that barbarian and savage cultures were but forms of arrested development, and indicated very closely past stages of civilised communities.

But a fresh school of thought has come into prominence. According to this new view discoveries are made but once, and when resemblances are found between the cultures of different communities, even though widely separated, this is due to some connexion between them. According to the new school, the development of civilisation has been proceeding by many different paths, in response to as many types of environment, but these various advances have frequently met, and from the clash of two cultures has arisen another, often different, more complex, and usually more highly developed than either of its parents.

The old school looked upon the advance of culture as a single highway, along which different groups had been wandering at varying paces, so that, while some had traversed long distances, others had progressed but a short way. The new school, on the other hand, conceives of each group as traversing its own particular way, but that the paths frequently meet, cross, or coalesce, and that where the greatest number of paths have joined, there the pace has been quickest.

The older school, basing its views of the development of civilisation upon the doctrine of Evolution, has called itself the Evolutionary School. The newer, while believing no less in Evolution, feels it a duty to trace the various stages through which each type of civilisation has passed, rather than to assume that these stages have followed the succession observable elsewhere; thus, as historical factors form a large part of its inquiry, it has been termed the Historical School.<sup>2</sup>

The first note announcing the coming change was sounded from this chair eleven years ago,<sup>3</sup> and during the interval which has elapsed the new school has gained many adherents. All will not subscribe to the dictum that no discovery has been made twice; nevertheless there is a tendency not to assume an independent origin for any custom until it has been proved that such could not have been introduced from some other area.

These tendencies have led the anthropologist to inquire into the history of the peoples whose civilisation he is studying, and to note, too, minute points in their environment. At the same time geography began to take special note of man and his doings. This anthropogeography concerned itself with inquiring into the

actions between man and his environment, and though at first the environment was the main object of the geographer's attention, he is now inclined to pay more attention to its effect upon man. Thus anthropology and geography have been drawing closer, and as the latter is a recognised subject in our schools, no small amount of anthropological knowledge has been instilled into the minds of our boys and girls.

It might have been expected that the historians before the geographers would have been attracted to the anthropological approach, but recent events have up to now engrossed their attention. Signs have not been lacking, however, that the study of peoples and their customs, rather than of kings and politicians, is gaining ground, and we may look with confidence towards closer relations between the studies of history and anthropology.

Again, we may notice an increasing interest in our subject among sociologists and economists. These have focussed their attention upon the social organisation and economic well-being of civilised communities, with the view of presenting an orderly array of facts and principles before the political leaders. There has, however, been a tendency to trace these modern conditions back into the past, and to use for comparison examples drawn from the social organisation or economic conditions of communities living under simpler conditions. While these studies overlap those of the anthropologist, the methods used are different. We are working from the simple to the complex; they begin with highly developed conditions and thence work back to the primitive.

Lastly, we must not forget the students of the classical languages. In spite of many advantages which they possess at schools and universities, they have been losing in popularity, and the reason is not far to seek. So long as there were fresh works to be studied and imperfect texts to be emended, there was no lack of devotees to classical literature. Later, comparative philology gave fresh life to such studies, and certain views current among mid-nineteenth-century philologists gave also an impetus to the re-study of Greek mythology. But about 1890 such studies became unfashionable, and many classical scholars turned to anthropology with great advantage both to themselves and to us.

It is doubtless as a result of these converging movements that the general public is taking an interest in anthropological studies, and that works of a general nature, summing up the state of knowledge in its different branches, are in great request. The educated public wish to know more of the science of man, yet I fear they are too often perplexed by the discordant utterances of anthropologists, many of whom seem to be far from certain as to the message they have to deliver.

In their turn not a few anthropologists feel a like uncertainty as to the ultimate purpose of their studies, and are not clear as to how the results of their investigations can be of any benefit to humanity. These are points well worthy of consideration; for, as we were reminded from this chair two years ago,<sup>4</sup> anthropology, if it is to do its duty, must be useful to the State,

<sup>1</sup> From the presidential address delivered to Section H (Anthropology) of the British Association at Hull on September 7.

<sup>2</sup> Rivers, W. H. R., "History and Ethnology," *History*, v. 65-7, London

<sup>3</sup> (1912).

<sup>4</sup> Rivers, W. H. R., "The Ethnological Analysis of Culture," Report of Brit. Assoc., 1911, 499-2.

<sup>4</sup> Karl Pearson: Address to the Anthropological Section, Brit. Assoc. Report, 1920, 140-1.

or to humanity in general. Even the scope of the science is by no means clear to all, and would be differently defined by various students. It may not be out of place, therefore, to consider in detail the scope and content of anthropology, then its aims and the services it may render to mankind.

To the outside world anthropology seems to consist of the study of flint implements, skeletons, and the ways of savage men, and to many students of the subject its boundaries are scarcely more extensive. Yet civilised people also are men, and anthropology should include these within its survey. That other scientific workers, historians, geographers, sociologists, and economists, study civilised man is no reason why the anthropologist should fail to take him into account, for his point of view differs in many respects from theirs. I would suggest, therefore, that all types of men, from the most civilised to the most primitive, in all times and in all places, come within the scope of anthropology.

Anthropology is the study of man, but we need a more accurate definition. A former occupant of this chair has declared that "anthropology is the whole history of man as fired by the idea of evolution. Man in evolution—that is the subject in its full reach." He adds: "Anthropology studies man as he occurs at all known times. It studies him as he occurs in all known parts of the world. It studies him body and soul together."<sup>5</sup>

Anthropology may, therefore, be defined as the study of the origin and evolution of man and his works. What, then, separates anthropology from the other studies which are concerned with man is, that the anthropologist studies him from all points of view—that his is a synthetic study; above all, that evolution is his watchword; that his study is, in fact, not static but dynamic.

If, then, we grant that anthropology is the synthetic study of the evolution of man and his manifold activities, we are dealing with a subject so vast that some subdivision becomes necessary if we are to realise what the study involves. Such divisions or classification must be arbitrary, but we may consider the subject as divided primarily into two main categories: "man" and "his works."

But man himself cannot be considered from one aspect only, and it seems fitting that the anthropologist should consider that man consists of body and mind; the study of these is the special province of the anatomist, the physical anthropologist, and the psychologist. Here, again, it may be asserted that anatomy and psychology are distinct sciences, but anatomy, in so far as it helps us to understand the evolution of man, and again as it helps us to trace the variations in the human frame, is and always has been reckoned a branch of anthropology. Again, in the case of psychology, there is much which is not, strictly speaking, anthropological. On the other hand, in so far as psychology enables us to trace the development of the human mind from that of the animal, and in so far, too, as it can interpret the causes which have led to various forms of human activity, it is a branch of our science. If, too, it can help us to ascertain whether certain fundamental mental traits are normally associated with certain physical types, psychology will provide anthro-

<sup>5</sup> Marett, R. R., "Anthropology," p. 1.

polo- gists with a means of interpreting many of the phenomena which they have noted but cannot fully explain.

The works of man are so varied that it is no easy task to classify them. We may, however, first distinguish the work of man's hands, his material culture, from his other activities. Under this heading we should include his tools, weapons, pottery, and textiles; his dwellings, tombs, and temples; his architecture and his art.

Next, we have the problems concerned with language, which we may consider as dealing with the means whereby men hold intercourse with one another. This heading might well include gesture at one end and writing at the other. Hitherto anthropologists have confined their attention too exclusively to the tongues of backward tribes, and left the speech of more advanced peoples to the philologists. I would plead, however, that language is such an essential element in human culture that comparative philologists might well consider themselves as anthropologists.

Lastly, we have social organisation and all that may be included under the terms "customs" and "institutions," a varied group, leading to the study of law and religion. Here, again, we come in contact with other studies—those of the lawyer, political economist, and theologian; but though the anthropologist is studying the same facts, his range is wider and his outlook more dynamic.

Thus it will be seen that in the three divisions of man's work, as well as in the two aspects of man himself, the anthropologist finds other workers in the field. But whereas these other sciences are concerned only with some part of man and his works, and are limited frequently to recent times and civilised communities, it is the province of the anthropologist to review them as a whole, in all times and in all places, and to trace their evolution from the simplest to the most complex.

If we accept the views of the historical school, anthropology becomes a new method of treating historical material. It is, in fact, the history of man and his civilisation, drawn not so much from written documents as from actual remains, whether of material objects or of customs and beliefs. It is concerned with wars only so far as these have produced a change in the population or language of a region. It is interested in kings only when these functionaries have retained customs indicative either of priesthood or divinity. It is interested less in legal enactments than in customary institutions, less in official theology than in the beliefs of the people; the acts of politicians concern it not so much as do the habits of humbler folk.

From some points of view anthropology may be considered as a department of zoology. A century ago zoologists were engaged in studying the higher animals, and for a time neglected the "radiate mob." Then all interest was focussed upon lowly forms, and the protozoa occupied a disproportionate part of their attention. Lately, again, their work has been more evenly distributed over the whole field. This choice of groups for special study was not due to mere caprice. The more obvious forms of life were first studied; then attention was focussed upon the simpler organisms; for, from the study of these, the zoologist was able to grasp

the underlying principles of life. These lessons learnt, he was able to attack the problems affecting the welfare of mankind.

So with the student of man. For many centuries historians, philosophers, and theologians have been studying the ways of civilised humanity, though not by the methods of the anthropologist. For, just as they were attracted by the higher groups of men, so were they fascinated by the more conspicuous individuals. During the nineteenth century, students were attracted towards the backward types of humanity, partly because of their very unlikeness to ourselves, and of recent years because they felt that the customs of these peoples were fast disappearing. But from a scientific point of view, the paramount reason was because it was felt that in such simple societies we should find the germ from which human civilisation had begun.

Much of the force of this last argument is disappearing as the evolutionary school gives place to the historical. We are becoming aware that the civilisation of backward peoples is more complex than was at first believed. We are giving up the belief that such people have preserved our ancestral types alive to the present day, for we are realising that they represent not so much our ancestors as our poor relations.

Though we must abandon the ancestral view, and cease to believe that these backward communities represent to-day the conditions under which we dwell in the past, the institutions of these folk are in many respects less complex than our own, and it is possible to study them from every aspect with far greater ease than we could do in the case of one of the higher civilisations. Since it is the function of anthropology to study man synthetically, this is a great advantage. When dealing with these simpler problems we can evolve a method and a discipline to be applied in more complicated cases. Again, the backward peoples have no written history, and we are forced in this case to restore their past by other means. This has led to the development of fresh methods of attacking the problems of the past, which may prove of value in the case of more advanced communities.

For these reasons the study of backward peoples still has great value for the anthropologist. He has not yet solved all the problems concerned with the dawn of civilisation, nor has he yet perfected his methods and discipline. More workers and expert workers are needed in this field, and so it is that our universities devote the greater part of their energies to training students for this purpose. There are many students, however, who cannot visit wild lands to study the ways of their inhabitants. Some of these, it is true, may sift the material collected by their colleagues, though they will be at considerable disadvantage if they have had no personal experience of the people with which their material deals.

The time seems to have arrived when anthropologists should not concentrate so exclusively upon these lowly cultures, but might carry on their researches into those civilisations which have advanced further in their evolution. Not that I wish to deprecate in any way the study of backward peoples, or to discourage students from researches in that direction; but I would suggest that some anthropologists might initiate a closer

inquiry into the conditions of more civilised peoples, in addition to the studies already described.

We have in the Old World three great centres of culture, each of which has been in the van of progress, and each of which has contributed to the advance of the others. These are the civilisations of China, Hindustan, and what I will call the European Region.

Though our relations with China and Japan have been intimate for several generations, and many of our compatriots are familiar with both countries, it is surprising how little we know of either of these people from the anthropological point of view. This is the more to be regretted since for more than half a century Japan has been adopting features from Western civilisation, while there are signs that the same movement is beginning in China. So far those who have made themselves familiar with the languages of the Far East have studied the art, literature, philosophy, and religion of these regions, rather than those aspects which more properly belong to our subject.

What concerns us more nearly in this country is the Indian Region. Here we have a well-defined province, peopled by successive waves of different races, speaking different languages, and with different customs and beliefs—an apparently inextricable tangle of diverse elements in various stages of cultural evolution. A vast amount of material has been gathered in the past, though such collecting has not been proceeding so fast during the last generation; but basic problems are still unsolved, and seem at times well-nigh insoluble. Perhaps it is this superabundance of material, or it may be the apparent hopelessness of the task, which has diminished the interest taken in these studies during the past few years. This attitude is regrettable, and the only redeeming feature is the extremely active and intelligent interest in these problems now taken by various groups of Indian students, especially in the University of Calcutta.

I have suggested that perhaps the lack of interest in such matters among Anglo-Indians, and especially among members of the Indian Civil Service, may be due to the apparent hopelessness of reaching a solution of any of the problems involved. It may also be due to the fact that they are sent out from this country to govern a population with different cultures and beliefs, and traditions wholly unlike those of this continent, without having received in most cases any preparation which will enable them to study, appreciate, or understand an alien civilisation. Thus they misunderstand those among whom they are sent, and are in turn misunderstood. Guiltless of any evil intent, they offend the susceptibilities of those among whom their lot is cast, and acts are put down to indifference which are only the product of ignorance. After making their initial mistakes the more intelligent set to work to study the people committed to their charge, but faced with problems of extreme intricacy, and without any previous training, more often than not they give up the attempt as hopeless.

That candidates for the Indian Civil Service should receive a full training in anthropology before leaving this country has been pleaded time after time by this Section and by the Anthropological Institute, and though I repeat the plea, which will probably be as useless as its predecessors, I would add more. The problems con-

fronting the anthropologist and the administrator in India are of such extreme complexity that it needs a very considerable amount of combined action and research even to lay down the method and the lines along which future inquiries should be made. Such a school of thought, such a nucleus around which further research may be grouped, does not yet exist; the materials out of which it can be formed can scarcely yet be found. Yet until such a nucleus has been created, and has gathered around it a devoted band of researchers, no true understanding will be found of the problems which daily confront both peoples, and the East and the West will remain apart, subject to mutual recriminations, the natural outcome of mutual misunderstanding.

One solution only do I see to this dilemma. For many years past there have been institutions at Athens and Rome, where carefully chosen students have spent several years studying the ancient and modern conditions of those cities and their people. By this means a group of Englishmen have returned to this country well informed, not only as to the ancient but the modern conditions of Greece and Italy. Besides this we have had in each of the capitals of those two States an institution which has acted as a centre or focus of research into the civilisation of those countries. Although the main objects in both cases have been the true understanding of the cultures of the distant past, the constant intercourse of students of both nationalities working for a common end has resulted in a better understanding on the part of each of the aims and ideals of the other. I have no hesitation in saying that the existence of the British Schools at Athens and Rome has been of enormous value in bringing about and preserving friendly relations between the people of this country and those of Greece and Italy.

I cannot help feeling that a similar institution in India, served by a sympathetic and well-trained staff, to which carefully selected university men might go for a few years of post-graduate study, would go far towards removing many of the misunderstandings which are causing friction between the British and Indian peoples. Such a British School in India, if it is to be a success, should not be a Government institution, but should be founded and endowed by private benefactors of both nationalities. It would be a centre around which would gather all anthropological work in the peninsula, while it would enable the British students to arrive at a truer understanding of Indian ideals and help Indians to grasp more fully the relations subsisting between the Indian and European civilisations.

Lastly, we come to the European Region, extending southward to the Sahara, and eastwards to Mesopotamia. Throughout this region the racial basis of the population is similar, though the proportion of the elements varies. Also throughout the region there has been, from the earliest days, free communication and no great barriers to trade and migration.

Until the last fifteen hundred years the civilisation of this area was fairly uniform, though its highest and earliest developments were in the south-east, while the northern zones lagged behind and were on the outer fringe. Nevertheless it formed from palæolithic times one cultural region, and this became more marked and

homogeneous during the days of the Roman Empire. Two forces from without destroyed that mighty empire and divided the region into two halves; and as each of these forces adopted different religious views, the European cultural region became divided into two. We have, therefore, to treat the European cultural region as two, the civilisations of Islam and Christendom.

Though the separation of these two halves is relatively recent, their ideals have grown divergent, while the inhabitants of both zones are no nearer to a true understanding of one another. Political difficulties in the Near East are the natural result of such misunderstandings, and the remedy here is to achieve a truer appreciation of other points of view. A more thorough knowledge of the anthropological factors of the case seems to be a necessary preliminary to such mutual understanding, and since the League of Nations and the Versailles Treaty have seen fit to add to our responsibilities in this area, it is an urgent necessity that some of our anthropologists should pay closer attention to the problems of the Near East.

And now with regard to Christendom. Are we to consider that our duties as anthropologists end with alien cultures? Is Christendom so united that misunderstandings cannot arise within its borders? At the close of a great war we can scarcely claim that there is no room for our studies.

There has been a tendency hitherto to regard anthropology as a science dealing with backward peoples, and it has been felt that to apply its principles to neighbouring peoples might be looked upon as an insult. If, however, we agree that all mankind are fit material for the anthropologist's investigations, we need have no hesitation in studying their material culture, social organisation, and religious beliefs, just as already, for practical purposes, we study their languages. There is not a country in Europe in which we may not find features of an anthropological nature which separate its population from the inhabitants of other areas. It is these differences which come to the front when trouble is brewing, and these are the factors which we need to understand if we are to avoid giving offence in moments of national irritation. Constant travel by people alive to the importance of such inquiries will in time so influence the public opinion of many of the nations of Europe that misunderstandings will be less frequent, and national sensitiveness less prone to take offence at words and actions which are not intended to provoke.

But it is not only foreign countries and their inhabitants which the anthropologist needs to study. In every country there are different strata in the population which have different customs and a different outlook. The British Isles are no exception to this rule; history records the successive arrivals of Romans, Saxons, Danes, and Normans, and the study of prehistoric remains shows us that these invasions have been preceded by a greater number in earlier days. Just as the physical type of the Briton is far from uniform, so are his mental outlook and his ideals and beliefs. Quite apart from the differences observable in the different countries which compose our group of islands, we find also that the population insensibly divides itself into classes, differing but slightly except in name from what we know in India as castes. These classes in the British

Isles have had their origin in the successive waves of conquest which these islands have suffered. Individuals have freely passed from one class to another, but though the individuals have changed the classes have remained. Owing to the constant interchange in blood the physical characters of the different classes are much alike, as are their fundamental mental traits, but in material culture, language, social organisation, and to some extent religious beliefs, they differ widely. Here then again, in our own country, there is work for the anthropologist who never leaves these shores.

Turning now to the aims of anthropology and to the means whereby it may become of service to the State and to mankind in general, we see that it is of the utmost importance that those who are sent to govern or administer areas and districts mainly occupied by backward peoples should have received sufficient training in the science to enable them, in the shortest possible space of time, and consequently with the fewest possible initial mistakes, to govern a people whose customs, traditions, and beliefs are very different from their own, without offending the susceptibilities of their subjects.

We are an Imperial people, and during the last few centuries we have taken upon ourselves a lion's share of the white man's self-imposed burden, and the lives and well-being of millions of our backward brethren have been entrusted to our charge. Recent events have, by means of mandates, added largely to our responsibilities in this respect. We, of all nations, cannot disregard this fundamental duty of despatching our proconsuls fitted to undertake these great responsibilities.

But the burden we have undertaken extends not only to backward peoples; we have been called upon to govern or to advise the governments of peoples who have a civilisation little, if at all, inferior to our own, and to whom at one time we have been indebted for much of the culture that we now enjoy. The civilisations of these regions are infinitely more complex, and the people are not homogeneous, but are divided into numerous sections, differing in language, religion, and social customs. In these regions we meet with anthropological problems of infinite difficulty and complexity, on the solution of which depend the peace and well-being of the population. Yet our representatives go to take up their duties in these lands with little or no previous training, and it is only a marvel that errors of tact, due to ignorance, are not more common.

In these civilised regions race consciousness has been growing fast during the last half-century, and errors of tact and manners, which were submitted to in former times, though not with a good grace, are now actively resented, and the old methods of government are discredited. It may not yet be too late to remedy this evil, if no time is lost in giving a full anthropological training to those who are sent to administer these regions.

But we are not only an Imperial people, governing and administering regions with alien populations; we are also a wandering and adventurous people. The nomadic spirit of our ancestors is still alive within us; our ships, like those of the Vikings of old, are to be seen in every sea. So it comes that our people will be found in all lands and all climates from the Arctic circle to the Equator.

All these wandering Britons come in contact with the inhabitants of the lands they visit, creating various impressions, sometimes good, more often bad. Had they a fuller knowledge of the customs and opinions of the people they visit, or even a truer appreciation of the fact that diverse customs and opinions exist and should be respected, we should not have to record the creation of so many bad impressions. Luckily our people, as a rule, have much common sense, and often a desire to please, so this trouble is thus to some extent mitigated; but the difficulties that have arisen from ignorance of the ways of others, from too insular an outlook, in fact, from a lack of appreciation of the anthropological standpoint, are making us and our government heartily disliked in nearly every quarter of the globe. It is to remedy these difficulties, and the danger to the peace of the world which is threatened thereby, that I would advocate an increased study of anthropology by all sections of the community. Herein lies one of the chief means by which our science may become of service to mankind.

It is not my business to draft a scheme for the furtherance of anthropological studies. Two of our universities offer degrees in this subject, and others a diploma; courses of instruction on some sections of the subject are given there and elsewhere. Many teachers of geography are introducing much anthropological matter into their curricula, and there are signs that some historical teachers may follow suit, so that the subject-matter, if not the name, is not unknown in some of our schools. But we have much lost time to make up and the matter is urgent.

We cannot, of course, expect all our people to be trained anthropologists and to understand fully all the ways of the people they may chance to meet in their wanderings. What matters far more is that they should appreciate the fact that different peoples have had different pasts and so act differently in response to the same stimuli. Further, that all this diversity has its value; that we cannot be sure that one culture is in all respects superior to another, still less that ours is the best and the only one which is of consequence. It is not so much the facts that matter as the spirit of anthropology; we need not so much that our people should have anthropological knowledge as that they should learn to think anthropologically.

It is needless for me to remind you that the world is in a state of very unstable equilibrium—that the crust is, so to speak, cracked in many places, and that the fissures are becoming wider and deeper, and that fresh fissures are constantly appearing, not only in distant lands but nearer home. Again, this crust, if I may continue the geological metaphor, is stratified, and there are horizontal as well as vertical cleavages, which are daily becoming more marked. It is to the interest of humanity that these breaches should be healed and the cracks stopped, or we may find the civilisation of the world, which has grown up through long millennia at the cost of enormous struggles, break up into a thousand fragments. Such a break in the culture of the European Region followed the dissolution of the Roman Empire, and more than a thousand years were needed to heal it; nay, some of the cracks then made have never yet been closed.

Anything that may help to avert such a disaster is

important to the human race, and there is no greater danger at present than the alienation of the peoples of Asia and the Near East. Much of the ill-feeling engendered in India, Egypt, and elsewhere is the product of misunderstandings, due to a lack of appreciation on

both sides of the opinions and views of the other party, and there seems to be no better method of removing such misunderstandings than a sympathetic study of one another's culture; to this end anthropology offers the most hopeful approach.

### Obituary.

DR. DAVID SHARP, F.R.S.

DR. DAVID SHARP, whose name, it has been well said, is a household word wherever the science of entomology is pursued, died on August 27 at his home at Brockenhurst. His love of entomology, the great and continuing enthusiasm of his life, dated from his early childhood. Born in 1830 at Towcester, Northamptonshire, his early years were passed at Whittlebury, Northants, and at Stony Stratford. His parents later moved to London, and it was at Loudoun Road, St. John's Wood, that Herbert Spencer was an inmate of Sharp's father's house, as Spencer himself has related in his autobiography. Sharp himself said that his youthful intimacy with Spencer had influenced him considerably, and throughout his life he retained in Spencer's work an interest which found expression in the publication in 1904 of an article on "the place of Herbert Spencer in biology."

Sharp was destined by his father for a business career, but, finding this uncongenial, he studied medicine in London and afterwards at Edinburgh University, where he graduated in 1866 with the degrees M.B. and C.M. Specialising in the treatment of mental illnesses, he resided for some years at Thornhill in Dumfriesshire. He left Scotland in 1884 and lived at Shirley Warren, Southampton, and afterwards at Wilmington, near Dartford, Kent. Early in 1890 he was appointed curator of the insect collections of the University Museum of Zoology, Cambridge, a post which he resigned early in 1909. He then retired to Brockenhurst, where he passed the rest of his days.

Most of his multitudinous writings are systematic works on the Coleoptera, to which he devoted the greater part of his life, but many deal with other insects or with life-histories, or have a still wider bearing, for his learning extended to a wonderful degree over the whole field of entomology. He had an unrivalled knowledge of the British Coleoptera, and already in 1869 had published a monograph of nearly 200 pages on the obscure genus *Homalota*. His list of the Coleoptera of Scotland appeared in the early volumes of the *Scottish Naturalist*, and he published two catalogues of the Coleopterous fauna of Britain, the second in collaboration with Canon W. W. Fowler. His numerous other studies of British beetles form a series of papers continuing to the last years of his life.

Sharp's biggest works on foreign Coleoptera are the monograph of water-beetles (Dytiscidae) published by the Royal Dublin Society in 1882, and his contributions to the "Biologia Centrali-Americana." In the latter he wrote the whole of the volume on Adephaga and Staphylinidae, more than 800 pages, the greater part of the volume on Clavicorns, and three other important sections. He also published in 1876 a paper of nearly 400 pages on the Staphylinidae of the Amazons. On

New Zealand beetles, a fauna in which he was specially interested, he produced a long series of memoirs. One can barely allude to his papers on the beetles of Japan, an important series, and to others on those of Ceylon, Southern India, the White Nile, etc., with many more, far too numerous to mention. Systematists, knowing the work required for the production of a single careful description, will appreciate the immense amount of toil needed to achieve these results. Special mention must be made of Sharp's work on the faunas of islands. A series of earlier papers on Hawaiian beetles was but the prelude to his labours as secretary of the committee appointed in 1890 to investigate that fauna, and as editor of the three large volumes of the "Fauna Hawaiianis," of which he himself wrote several considerable parts. He was moreover a member of the committee appointed in 1888 to examine the flora and fauna of the West Indies.

Of his more general writings undoubtedly the best known are the two volumes on insects in the "Cambridge Natural History," published in 1895 and 1899 respectively, which at once became standard works. His memoir (1912) written in collaboration with Mr. F. Muir on "the comparative anatomy of the male genital tube in Coleoptera" is a masterly treatise, on the production of which the breadth of his learning was brought to bear. In 1873 appeared his pamphlet on "the object and method of zoological nomenclature," in which he elaborated the view that nomenclature requires, for the maintenance of continuity of knowledge, fixed names for the species of animals, while changing ideas as to classification need shifting names for their expression. He advocated that the two names, generic and trivial, originally given to an animal should always be preserved intact, even though it may subsequently be placed in several different genera at different periods. He held also that the analytic system of Linnaeus, in which species are treated as fractions of genera, broke down almost at once, and that only by a synthetic system could progress be made; that species must first be rightly understood, and then grouped into genera. These ideas he carried into practice in his monograph of the water-beetles, but in his later works he did not adhere strictly to the system of naming there used. In the introduction to that monograph he also expressed some of his views on the origin of species, an example of his cautiousness with regard to accepted ideas. He also discussed the phylogeny of insects in the proceedings of the Congress of Zoology held at Cambridge in 1898; and the senses, especially the sight, of insects in his retiring presidential address to the Entomological Society (1888). To him are due the articles on "Termites" and "Insects" in the volumes of the "Encyclopædia Britannica" issued in 1902, as is also (in part) that on "Hexapoda" in the later edition (1910).

Perhaps Dr. Sharp's greatest service to zoology was in connexion with the "Zoological Record." Of this he became general editor in 1892, and he only laid the work down a few weeks before his death. Throughout this period he was also recorder of all the literature on insects. He improved the volumes immensely, and raised the classified subject-index to a wonderful degree of efficiency.

So far allusion has been made only to his writings, but he also excelled as a field-worker and collector. Ever laying great stress on the importance of the collection and permanent preservation of material, he published several articles on these points. His collection of British Coleoptera is as fine as any, and he also made a very large foreign beetle collection, the greater part of which, consisting of some 150,000 specimens, was acquired by the British Museum in 1905. During his time at Cambridge he amassed a large amount of material for that Museum. His fine library was recently purchased by the Cawthron Institute at Nelson, New Zealand.

Dr. Sharp was a wide reader, and though of rather slight bodily frame he had, even to an advanced age, great powers of endurance as a field-worker, and an almost unlimited capacity for mental work. No time was ever lost in picking up the threads of his work, so that even short intervals were used to the full. He was Hon. M.A. of Cambridge; elected F.R.S. in 1890; fellow, and former councillor of the Zoological Society. He joined the Entomological Society in 1862 and was president in 1887 and 1888, besides holding lesser offices on several occasions. He was also an honorary or corresponding member of the New Zealand Institute and of the principal entomological societies of the world.

H. S.

#### DR. WILLIAM KELLNER.

DR. WILLIAM KELLNER, who died at Charlton, on September 12, in his eighty-third year, was born at Frankfort in 1839, and received his scientific training under Prof. Wöhler at Göttingen, finally obtaining his Ph.D. degree in that university. He became a Fellow of the Institute of Chemistry in 1878 and served on the Council from 1895 to 1898. In 1862 he came to England as assistant to Sir Henry Roscoe, at Owens College, Manchester, whence, in 1864, he went to

Woolwich and joined the staff of the War Department chemist (Sir Frederick Abel). In his early years at Woolwich Dr. Kellner was engaged in the varied general work of the chemical department. Later his main work became investigatory and experimental, both in connexion with explosives, as also to meet the requirements of the various Commissions and Committees on which the War Department chemist was a prominent member; of these the "Royal Commission on Accidents in Mines" and "The Explosives Committee" (appointed in 1889 to produce a smokeless powder for the Service) may be mentioned.

Dr. Kellner also devoted much work to the production of an apparatus for determination of the flashing point in oils, and was largely responsible for the Abel flash point apparatus, eventually perfected; in collaboration with Sir Boverton Redwood he carried out an exhaustive series of tests with this apparatus.

As a scientific worker Dr. Kellner was painstaking and methodical, displaying much skill in devising experiments to assist in elucidating the various problems confronting him in the course of his work. As regards practical results his most important work was in connexion with the evolution of cordite, much of the more difficult research and experimental work leading to the production of this explosive being carried out by him in the chemical department at Woolwich Arsenal; in spite of the numerous smokeless powders which have been brought into use since, the fact that, after a period of thirty years, cordite still remains the British Service propellant for army and navy use, is perhaps the best testimonial to the thoroughness of his work in this direction.

In 1892 Dr. Kellner succeeded Sir Frederick Abel as chemist to the War Department, and in addition to the duties of this office, served as an associate member of the Ordnance Board and as consulting chemist to the Royal Gunpowder Factory at Waltham Abbey; he retired from the service in 1904.

WE much regret to announce the death on October 2, at fifty-eight years of age, of Col. E. H. Grove-Hills, F.R.S., formerly head of the Topographical Department of the War Office and the author of a number of papers on astronomical subjects.

### Current Topics and Events.

H.R.H. THE PRINCE OF WALES has graciously accepted an invitation to be present at a joint dinner of the Institution of Mining Engineers (representing coal-mining engineering) and the Institution of Mining and Metallurgy (representing the mining of minerals other than coal) to be held on Thursday, November 16. The dinner will be held at the Guildhall by permission of the Corporation of the City of London.

IN his presidential address to the British Association at Edinburgh last year, Sir Edward Thorpe referred to the difficulty which is encountered by many workers in science of being unable to obtain all the scientific books they require owing to lack of

means. Sir Robert Hadfield has now generously offered to contribute a sum of 50*l.* per annum for three years, to be expended in supplies of books to those who are engaged in scientific pursuits and are unable to purchase for themselves. The council of the British Association has at present under consideration the best means of allocating this gift.

AMONG many important accessions of manuscripts to the Library of Congress (Washington) noted in the librarian's report for 1921, we observe the papers and correspondence of the late Major-General W. C. Gorgas, and the diaries and note-books of Jean Nicholas Nicolle, the explorer of the upper Mississippi, Missouri, Red, and Arkansas rivers in the first



half of the nineteenth century. The division of maps has received many rarities. An increase of receipts from the Central Powers is noted. "A large number of these were theses of German universities and institutes of technology, which goes to show that the work of these institutions was carried on during the war without interruption."

ACCORDING to letters received by the last mail, the International Congress of Americanists at Rio de Janeiro has been a very great success. An enormous mass of papers was presented, all of which the Government proposes to print in full. At the close of the meeting the majority of the members took advantage of the delightful excursions which had been arranged for their benefit. After some discussion it was decided to hold the twenty-first session of the congress in 1924 in Holland by invitation of the Dutch Government, and in 1925 at Gothenburg, Sweden, by invitation of that town, where the museum is in charge of Mr. Erland Nordenskiöld, the well-known authority on South America. In 1926 the congress will meet in Philadelphia.

THERE are welcome indications that the work of investigating our national antiquities, interrupted by the outbreak of the war, is now being revived. The Congress of Archaeological Societies, in union with the Society of Antiquaries, London, has just issued the first number, for 1921, of "The Year's Work in Archaeology." This useful publication gives lists, arranged in the three kingdoms and their counties, of the progress of exploration. In a valuable supplement we have a list of the more important papers on the subject published by the local societies, and, though a large number of these societies are affiliated to the Congress, there is still room for the association of local workers in this important enterprise. The Congress makes an appeal for contributions in order to effect the purchase of Cissbury Ring, near Worthing. As this pamphlet shows, there are still considerable vandalism and destruction of important monuments; the Congress protests specially against the destruction of a portion of the Middlesex Grim's Dyke at Pinner Green, and other examples are quoted in the Report. Much important work is being done in connexion with the Archaeological Survey, and the president, Sir Hercules Read, remarks that there are many signs that we are at last becoming a civilised nation, as is shown by the Ancient Monuments Act and the appointment of the Congress Secretary, Mr. Crawford, to the newly created post of Archaeology Officer at the Ordnance Survey.

THE *Toronto Star* of July 6 last has a note on a method of marking trails leading to springs of water which is practised by Indians of Western Texas. Two heaps of rock roughly heaped together, one about three feet high, the second a little lower, are placed beside the track, usually on an elevation commanding a view of the country for some five miles or more. A sight is taken from behind the larger heap, over the smaller, to some object on the horizon, such as a tree or clump of

bushes. Near this object will be found a second pair of heaps of rock sighting on a second objective. This process is continued until the spring is reached. This primitive method of sighting a trail is of interest in connexion with the suggestions put forward by Mr. Alfred Watkins in his "Ancient British Trackways," recently noticed in these columns. He argued that many of the older roads in this country could be assigned to pre-Roman times on the evidence of what it was presumed were sighting marks, which must have been used in much the same way as the Indians are said to make use of these heaps of rocks. Mr. Watkin's theory, as was pointed out when it was under notice, undoubtedly holds good in many cases, especially in connexion with natural objects; in others, particularly in the case of mounds, moats, churches, etc., it appears more open to criticism.

THE Fifth Annual Report of the Imperial War Museum has recently been issued by H.M. Stationery Office, price 9d. (post free 10½d.). It is typewritten on 8 folio pages and reproduced by a multicopier. This at any rate shows a desire for economy, calculated to appease the public. The work of the museum during the year 1921-22 consisted in a complete survey of the whole collection, elimination of items of no technical value or historical interest, and the compression and concentration of the more valuable exhibits under definite headings and groupings. This was particularly the case with the Munitions and Air Force exhibits. Stress is laid in this report on the technical value of the collections and on the fact that many objects of our everyday life during the War have been preserved in this museum while they have disappeared elsewhere. Allusion is made to the proposal to utilise two galleries at present occupied by the Science Museum and certain galleries now occupied by the Imperial Institute. These proposals have, it will be remembered, evoked a great deal of opposition. The committee appointed to investigate on them has reported to the Cabinet, but no decision has yet been reached.

DR. DAVID STARR JORDAN proposes that the International Commission on Zoological Nomenclature should reject the following works from consideration under the Law of Priority:—Gronow, 1763, "Museum Ichthyologicum"; Commerson (as footnotes in Lacépède, "Hist. nat. des poissons," mostly 1803); "Gesellschaft Schauplatz," 1775-1781, an anonymous dictionary accepting the pre-Linnaean genera of Klein; Catesby, 1771, "Natural History of Carolina, Florida, and the Bahamas" (1731-1750), revised reprint by Edwards; Browne, 1789, revised reprint of "Civil and Natural History of Jamaica"; Valmont de Bonare, 1768-1775, "Dict. raisonnée universelle d'hist. nat." (several names accidentally binomial). By this all systematic names published as new in those works will be rejected as of the dates in question, but will remain available as of the dates when they were adopted by later authors of unquestioned status. It is hoped that the proposed action will extricate zoologists from an impasse into which they have been led by a divergence of views respecting the terms

"binary" and "binomial." Zoologists who may have opinions on this proposal, which they desire to lay before the Commission, are invited to communicate them in writing to any member of it, so that they may reach the Secretary at Washington, D.C., U.S.A., before September 1, 1923. They would do well first to consult Opinions Nos. 13, 20, 21, 23, and 24 issued by the Commission.

Those who are familiar with the history of the elements will know, and those who are not familiar can easily inform themselves of the fact, that Lavoisier included among the elements both light and heat, which he classified along with oxygen, nitrogen, and hydrogen. A more detailed study of his "Traité élémentaire de chimie" will show that before discussing the compounds of oxygen, nitrogen, etc., with other elements, he devoted a brief chapter to observations on the compounds of light and heat with different substances. The rapid development of chemistry soon led to the abandonment of these imponderable elements, which came to be regarded as different manifestations of energy. It is, therefore, of interest to read in the *Pharmaceutical Journal* of August 12 a letter in which Mr. Carol A. Cofman Nicoresti, B. ès. Sc. et Lettr., announces, as a final conclusion of his investigation of gaseous volume and pressure, "that heat and light are both material substances, that they enter into chemical combination with other elements, and that they are *thrown out by chemical reaction.*" It is perhaps a compliment to Lavoisier that even his untenable hypotheses should thus undergo resurrection; but that they should be put forward as original can only be taken as a sign of imperfect chemical education. In one other respect Mr. Nicoresti's growth as a student of chemistry appears to have been arrested at a period more than a century earlier than Lavoisier, since he asserts that after careful consideration he is driven to the conclusion "that there are no such things as *gases*, but that there is only *one* gas in nature. That explains why the gaseous laws are so uniform." In this respect he apparently adopts the views of Boyle and Mayow, and his chemical education appears to have been carried forward but little further than the period of Agricola, who "hinted that the gases in mines were manifestations of malignant imps."

In the will of Prince Albert of Monaco, who died on June 26 last, there are noteworthy gifts for scientific purposes. His farm at Sainte Suzanne is left to the French Academy of Agriculture, and the wish is expressed that the estate should remain a place for agricultural experiments, to demonstrate what science and determination can obtain from sterile lands. Dr. Jules Richard will receive 600,000 francs to enable him to complete literary and scientific works in progress, including the results of the oceanographic cruises and the preparation of the Bathymetric Chart of the Oceans. The proceeds of the sale of the yacht *Hirondelle*, all books and publications of a scientific nature, as well as certain personal effects, will go to the Oceanographic Institute at Paris and Monaco, while the Institute of Human

Paleontology in Paris is to receive any personal effects relating to the work carried on there. The Paris Academy of Sciences will receive a million francs, the income of which is to provide a prize to be awarded every two years, the nature of the prize to be indicated by the Academy, according to the needs of the moment; a like sum is bequeathed to the Academy of Medicine for a similar prize.

We learn from the *British Medical Journal* that the Carnegie Hero Fund trustees have awarded a medallion and an annuity of 130*l.* to Dr. John Spence of Edinburgh, in recognition of his valuable and heroic work in radiology. Dr. Spence was among the first in Scotland to take up research in X-rays and medical electricity, and as a result of radiological experiments he sustained serious damage to both hands, necessitating amputation of the right forearm. Dr. Spence is still carrying on his work as radiologist at Leith Hospital and Craighleith Hospital, Edinburgh.

I.R.H. THE DUKE OF CONNAUGHT has consented to unveil the roll of honour which has been erected at the Institution of Civil Engineers to the memory of its members and students who lost their lives in the war. The ceremony will take place at 4 P.M. on Friday, October 27.

At the next ordinary scientific meeting of the Chemical Society on October 19, Prof. T. M. Lowry will read a paper entitled "The Polarity of Double Bonds. An Extension of the Theories of Lapworth and Robinson," and it is hoped that a general discussion will take place. On Thursday, October 26, at 8 P.M., a lecture entitled "The Significance of Crystal Structure" will be delivered by Sir William H. Bragg, in conjunction with Prof. W. L. Bragg. This meeting will be held in the lecture hall of the Institution of Mechanical Engineers, Storey's Gate, S.W.1.

WEATHER reports from Captain Amundsen's arctic expedition will be sent from the ship *Maud* and included in the collective message broadcasted by wireless from the Eiffel Tower daily at 11 h. 30 m. G.M.T. These observations, according to the *Meteorological Magazine*, will commence on October 15.

It was announced at a meeting of the Chemical Society on October 5 that Prof. J. F. Thorpe had been nominated to fill, until the next Annual General Meeting, the office of treasurer, rendered vacant by the resignation of Dr. M. O. Forster, recently appointed Director of the Indian Institute of Science at Bangalore. Dr. J. T. Hewitt was nominated to fill the vacancy in the list of vice-presidents caused by Prof. Thorpe's appointment.

FROM the Report of the Castle Museum Committee to the Town Council of Norwich for 1921, just received, we learn that the Norwich Education Committee has appointed a special demonstrator to conduct round the museum organised parties of about 25 pupils accompanied by teachers. During the year 19,801 attendances were recorded, each class attending the complete series of demonstrations in sixteen weekly

visits. The first lecture dealt with the purpose and methods of a museum, the next thirteen with various forms of animal life, the fifteenth with the early history of man, and the last with the story of the rocks and fossils. We understand that other Education Committees think of following this excellent example.

MR. H. E. STONE, of Sidcup, Kent, has forwarded to us a photograph of a specimen of *Datura Stramonium* which has attained a height of 28 inches with a foliage span of  $58 \times 24$  inches, and bears 25 well-developed seed-pods. The plant is undoubtedly a fine specimen, although not unusually large. The largest plants are often found on rubbish-heaps made up of garden refuse, and also as weeds in cultivated ground. Such plants benefit by their isolation as much as by rich food material. Cultivated plants are often allowed to stand too close together to be

able to develop to their full extent, while they usually lack the rich food material available in the case of isolated plants, and particularly those that have sprung up as weeds.

THE London agency of the Smithsonian Institution, Washington, which, since 1871, has been carried on by Messrs. William Wesley and Son, 28 Essex Street, Strand, London, has been removed to the premises of the new firm of Messrs. Wheldon and Wesley, Ltd. (incorporating William Wesley and Son), at 2, 3, and 4 Arthur Street, New Oxford Street, W.C.2. The large number of societies, museums, and institutions which forward their publications for transmission to their American correspondents through the International Exchange System of the Smithsonian Institution are requested to forward their consignments in the future to 2, 3, 4 Arthur Street, New Oxford Street, W.C.2.

### Our Astronomical Column.

THE SUNSPOT PERIODICITY.—Many attempts have been made to correlate the 11 year period of spot variation with the 11.86 year period of Jupiter's revolution. The latter, as it stands, differs too widely, and it is necessary to combine it with some other period. Prof. T. J. J. Sec, in a special number of *Astr. Nachr.*, vol. 216, attempts to combine it with 9.93 years, which is the period in which Jupiter gains a semi-revolution upon Saturn. He weights these two periods in the ratio 1.828 to 1, this ratio being the square root of that of Jupiter's mass to Saturn's mass. The result is 11.18 years, which is close to the sunspot period. But it is to be noted that while the 11.86 year period depends wholly on Jupiter, that of 9.93 years depends on both planets, so that the appropriateness of the above ratio is far from clear; apart from this the resulting period of two wave motions does not depend on the ratio of their amplitudes, but on the time that one takes to gain a revolution on the other. For example, the period from spring tides to spring tides is a semi-lunation, and this would not be altered by an alteration in the relative heights of solar and lunar tides.

It will be remembered that Prof. E. W. Brown also endeavoured to get the sunspot period from Jupiter and Saturn, though in a different manner. He was successful in predicting that the 1907 maximum would be a late one. Mr. E. W. Maunder directed attention to the cyclical shift of the spots in solar latitude synchronously with the variation in activity, which seems to indicate an internal rather than an external origin.

FLAMSTEED'S LETTERS TO RICHARD TOWNELEY.—This very interesting packet of letters was recently found at the Royal Society. Dr. Dreyer contributes a long article to the *Observatory* for September describing their principal contents. A few points may be mentioned here. Flamsteed was prompt in accepting Roemer's explanation of the annual inequality of Jupiter's satellites, due to the finite velocity of light. He studied refraction at low altitudes by measuring the change in the apparent vertical diameter of the sun.

We find from his notes on the great comet of 1680 that he was at that time still a believer in the vortices of Descartes, though he makes a note on Newton's different opinion. By 1686 Flamsteed had apparently become convinced of the overthrow of the system

of vortices; after alluding to the progress in the printing of the "Principia" he expresses his satisfaction in the immense gain that the new system will afford in the study of the planetary motions, "so that in the room of mourning I congratulate my own happiness."

It is rather melancholy to note how his opinion of Halley gradually changed from admiration to jealousy and suspicion. This seems to have been largely due to the association of Halley with Hooke, whom Flamsteed considered an enemy.

We share Dr. Dreyer's hope that the letters will be published in full.

PERTURBATIONS OF WOLF'S COMET.—Allusion was lately made in these notes to the work of M. Kamensky on this comet from its discovery in 1884 to the present time, and to the large changes in its orbit likely to arise from the very near approach to Jupiter this year. He has now calculated these changes, and gives the results in *Astr. Journ.* No. 807. The least distance occurred on September 26, when it was one-eighth of a unit, so that Jupiter's direct action was  $1\frac{1}{2}$  times that of the sun, and the assumption of elliptical motion ceases to be the smallest approximation to the truth. On the other hand, a remarkable approximation may be obtained by assuming the motion to be in a hyperbola about Jupiter, which is equivalent to treating the action of the sun on the two bodies as identical during the time of near approach. Incidentally this gives an opportunity for using the equations for hyperbolic motion, which are given in the text-books but very seldom employed. The results obtained by this simple method are quite close to those of the more rigorous investigation. A curious point is that the present perturbations are about equal in size but opposite in direction to those at the approach of 1875, so that the comet now returns very nearly to its 1875 orbit. The period is increased from  $6\frac{1}{2}$  to  $8\frac{1}{2}$  years, and the perihelion distance from 1.53 to 2.40. It fortunately happens that at the next perihelion passage, 1925, Oct. 28.4, the comet will be almost in opposition, so that the distance from the earth will attain its minimum value, 1.40. Prof. Kamensky hopes that it may not be beyond visual or photographic reach with large instruments; if it should be found, most of the credit will belong to him; if not seen then it will almost certainly be permanently lost.

## Research Items.

THE ROMAN BALANCE IN SOUTH AMERICA.—Mr. Erland Nordenskiöld has reprinted from the journal of the Société des Américanistes de Paris (N.S. vol. xiii., 1921) an article sub-entitled "Emploi de la balance romaine en Amérique du Sud avant la conquête." He produces evidence, with a full bibliography of authorities, to show that this invention was not confined to the Old World, but was found in the New World before the discovery of America.

ANTHROPOLOGY IN THE CHILTERN HILLS.—In the Journal of the Royal Anthropological Institute (vol. lii. Part 1), Mr. W. Bradbrouks and Prof. F. G. Parsons publish an elaborate memoir, with a long series of measurements of skull form, on the population of the Chiltern Hills, in which they arrive at the following conclusions: in this comparatively isolated area about half the working-class male people can trace their ancestry back to three generations in some part of the area; the hair colour is rather darker than Beddoe found in the Eastern and East Midland Counties, and the proportion is higher than in any other part of Great Britain, except the South-western Counties and Wales; the eye colour is identical with that of London and the East Midlands; the average cephalic index, 777, is practically that of the modern working man in London, and the average height, 5 ft. 7 in., is that of the black-haired individuals. Thus, the present-day inhabitants of the North Chiltern area, who are not recent immigrants, are distinctly darker haired than those surrounding them, and this darkness appears to be due to the survival of a great proportion of Neolithic or Mediterranean blood in the district.

DISTRIBUTION OF FUTURE WHITE SETTLEMENT.—The problem of the potentiality of the world for white settlement is attacked quantitatively by Dr. Griffith Taylor in the *Geographical Review* for July. The world is divided into economic regions which coincide in the main with Herberston's natural regions. The areas of these regions are determined by planimeter measurements. The factors influencing human settlement are grouped under four headings which comprise the dominant controls—temperature, rainfall, location, and coal reserves. Fisheries have local rather than general importance and are ignored. From the values of each of these four controls a quadrilateral graph, the econograph, is constructed for each region, and the area of the graph is found to represent approximately the habitability of the region concerned. The econograph is a rectangular figure formed on four axes which represent, respectively, the average annual temperature, the average annual rainfall, the average elevation, and the estimated total coal reserve of the region. In what Dr. Taylor believes to be the ideal region these values would be 55° F., 50 in., sea-level, and  $200 \times 10^4$  tons per square mile. The comparative value of these controls was apparently reached by assuming various values and testing them against the actual population map of Europe. By this means Dr. Taylor decided to give the temperature control double the weight of the rainfall and allow the coal factor, if large, to have equal weight with optimum temperature and rainfall combined. The ideal econograph represents 1000 units. All the seventy-four regions of the world have values below this ideal. The last step was to plot on a map of the world the numbers representing the areas and draw lines of habitability, called isoioketes. This map is of great interest as a partially successful attempt to forecast the future growth of white settlement.

MOSQUITO INVESTIGATIONS.—Since the statement was made by Messrs. Carter and Blacklock that *Anopheles plumbeus* is a potential carrier of malaria in this country, it having been experimentally infected by them, considerable interest has been taken in the habits and distribution of the species in Britain. Following studies made by these authors in the Liverpool district and in the Isle of Man, an inquiry was instituted by the mosquito investigation committee of the South-Eastern Union of Scientific Societies, acting on behalf of the Ministry of Health. The committee now announces that this special inquiry is concluded, and that *A. plumbeus* has been shown to be exclusively sylvan in habits, and to be widely distributed in England, occurring, when searched for, in almost any area in which are found beech, sycamore, chestnut, or other trees with water-containing rot-holes. The committee is now turning its attention to the mating and egg-laying habits of *A. plumbeus* and other species, which are still imperfectly known, and invites co-operation from observers in all parts of the country in elucidating these matters.

MUSCARINE.—In the Journal of the Chemical Society for September, Dr. Harold King, of the National Institute for Medical Research, records the isolation of muscarine, the highly potent and toxic principle of *Amanita muscaria*, the Fly Agaric, a common fungus of our birch woods. Muscarine has been the fertile subject of controversy among chemists and pharmacologists for more than fifty years, and it is now shown that the pure material differs essentially from the original claims as to its properties and constitution made by Harnack, upon whose work the whole of the subsequent edifice has been erected. There is no evidence that muscarine is related to choline or is a quaternary base. More than ordinary interest is attached to muscarine owing to its extreme specificity of localisation in the mammalian body and its complete antagonism by atropine.

A NEW SPECTRO-POLARIMETER.—Messrs. L. Bellingham and F. Stanley, Ltd., of 71 Hornsey Rise, have designed and provisionally protected a polarising prism which can be used either in the visible or ultra-violet region of the spectrum. The prism is constructed from one solid piece of Iceland spar cut in such a manner with respect to the crystallographic axis, and of such a length of side, that the extraordinary ray only is transmitted while the ordinary ray is absorbed at the sides. Two such prisms are placed side by side in a suitable mounting. Before being placed in contact the sides of each prism are ground away to give the required length of dividing line between the halves and also to produce the necessary half shadow angle. To provide a sharp face edge one of the prisms is allowed to project in front of the other, and the two are then bound together. It is claimed that such an arrangement is absolutely permanent and that the extinction is perfect. The entire absence of cement relieves the prism of all strain, and eliminates the possibility of light being diffused from particles in the cement or from scratches on the cemented surface. By employing such a polarising prism Messrs. Bellingham and Stanley have been able to construct a polarimeter which can be used either for visual observation, in conjunction with a mercury lamp, or for photographing the entire spectrum between wave-lengths  $230\mu$  and  $800\mu$  at one exposure.

The Fauna of the Sea-Bottom.<sup>1</sup>

By Dr. C. G. JOH. PETERSEN, Director of the Biological Station, Copenhagen.

STUDIES of the fauna of the sea-bottom are of essential zoological significance, and many scientific questions as well as important fishery interests depend upon them. The subject, however, is so extensive that I must confine myself mainly to the different methods adopted for the investigation of the fauna of the sea-bottom.

Since 1883 I have investigated Danish waters by means of the dredge; it was my task then to give on charts the distribution, especially in the Kattegat, of every single species of marine animal, to understand the laws ruling the distribution of the animals on the sea-bottom (the cruises of the gunboat *Hauch*). Different specialists had each a group of animals to work out, and a great number of charts were printed, but I did not feel quite content with my first publication, although something was cleared off by that method. The method was, and is still, the usual one for such investigations.

Many years later the question was put before me: Why does the plaice in the western Limfjord grow very slowly, but very quickly in the middle of the Limfjord? The answer required first of all a quantitative investigation of the amount of plaice-food in both places. A small bottom-sampler on a pole, long enough to reach the bottom in the shallow fjord was made in the 'nineties of last century and proved that much food was to be found in both places; the difference in growth-rate of the plaice was found later on to depend not only upon the amount of food on the bottom, but also upon the different number of plaice living there on each square mile. The idea of overcrowding for sea-fishes was introduced for the first time.

Many years later I constructed a new bottom-sampler fastened to a wire; this I have used everywhere in Scandinavian waters down to a depth of 300 fathoms. It was my idea at first to compare the amount of fish-food per sq. metre in the Limfjord with the amount of fish-food per sq. metre in our remaining waters by means of the bottom-sampler; but I soon found it difficult to compare the animals from one water with those of another; in some places the animals were small and of great value for fishes, in others the animals were bigger and built up of carbonate of lime (chalk) mainly, and with a great content of water; chalk and water being of course of little importance as food in the sea for other animals, I realised that I should compare, first of all, the amount of food in places with the same kind of animal population, and I had to map out these places.

The bottom-sampler taught me that we have about eight such different animal communities in Danish waters from 0 to 300 fathoms, characterised by numerous large and characteristic animals. They may be echinoderms, bivalves, crustacea, etc., but are all animals living mainly on detritus, not rapacious animals. These last named are necessarily always scarcer than the more peacefully living animals, as the grass-feeding animals on the dry land are more common than tigers and lions.

One thing puzzled me in the beginning very much; the bottom-sampler showed in many hauls the most uniform content in the sieves in the same animal community, then suddenly it came up filled with quite different animals, *Modiola modiolus*, *Trochophonia*, *Ophiopholis aculeata*, etc., without any corresponding difference in the depth or in the nature of the bottom. How is this to be explained?

<sup>1</sup> Opening of a discussion held in Section D (Zoology) of the British Association at Hull on Sept. 7.

All these new organisms were animals living not in the bottom like ordinary animals, but above the bottom, originally fixed to a small stone or a shell, as on a heath we may find lichens on stones, not heather, or as in a beech-wood, on stones we find mosses, not flowers; strong currents may help to nourish such an *epi-fauna* with its often enormously rich animal life. Every object on the sea-bottom, a stone, a shell, a wreck, living plants, may give rise to such epi-faunas; within the same community on the level sea-bottom there is the same epi-fauna, but in different communities different epi-faunas may be found. The epi-fauna is, as a rule, scattered over the bottom in spots, and it is not always easy, in single cases, to say what is the reason for its existence; it is therefore not possible to give its distribution on a chart; you may give it on the spots where you have found it, but you never will be able to give all the spots existing on the bottom. On rocky coasts the epi-faunas are dominating; the coral reefs are a kind of epi-fauna, built up mainly of chalk and water; they are of very little importance as fish-food.

In contradistinction to the distribution of the epi-faunas the communities of the level sea-bottom are of a very uniform distribution, in such localities as in Danish waters and in the North Sea. Their distribution may be easily mapped out, and their content of fish-food and other animals quantitatively determined. We have taken thousands of samples, each of  $\frac{1}{16}$  sq. metre, with the bottom-sampler in Denmark, and they have nearly always shown several animals, worms, bivalves, Ophiuridae, etc., in each; only one or two samples of them have shown no animal content.

By means of the bottom-sampler we may, therefore, using the most frequently occurring organisms, easily map out the communities of the level sea-bottom, and determine its content of fish-food.

The theory of probability will indicate the degree of accuracy; many samples will give, as a rule, more and more exactitude. We may determine how the number of organisms varies at different seasons and in different years. If we examine what the fishes eat of these organisms we may determine whether they are good or bad areas for this or that species of fish, and may get a fair idea of the productivity of the sea-bottom as a whole, not forgetting that all the small, fast-growing, short-living animals are often to be reckoned as yearly production, whereas the bigger, longer living animals must be reckoned by means of another method. We may get an idea of the whole metabolism of the sea—but I must not go too far in mentioning these problems.

With a good steamer I could in one month map out the whole of the North Sea as to its animal communities. I would take between 500 and 1000 samples spread over the whole of the North Sea, out to the 100-fathom line, about one or two per hour. Using a bottom-sampler of 0.2 sq. m. I should then have taken up only the animals of an area at 100-200 sq. m., but I am sure that I should get all the species of the common uniformly-distributed animals of the whole area, and I should be able to give a rough-sketched map of the animal communities. If we used a bottom-sampler on a heath only once, we should catch heather, and so in the sea, I should not catch many rare animals, but I do not care for rare animals; the main thing is to know the animals that make up the great bulk of the bottom population, to know their distribution and their weight per square mile. If you wish for greater exactitude than

this first trip could give, you may take more stations and investigate smaller areas more carefully.

I am glad to be able to say that in 1921 Dr. Russell, on the English steamer *John Bligh*, made the first trip across the North Sea with my bottom-sampler, guided by my assistant, Dr. H. Blegvad; they found some of the same communities between Lowestoft and Esbjerg as we know from the Kattegat.

Thanks to the bottom-sampler we can now speak about areas with a Venus mussel community, an *Amphiura filiformis* community, a *Brissopsis Amphiura chieriei* community, and so on, as we on land speak about a heath, a beech-wood, a meadow, etc.; we are also able to get a quantitative idea of the amount of animals on the sea-bottom, and are able to follow seasonal or other variations therein.

A dredge will sometimes give us, when well used, a bagful of animals, belonging to the epi-fauna as well as to the ordinary communities, and taken up from all the communities it has been towed over. The dredge is inclined, moreover, to take all animals *on*, not *in*, the bottom, and its content is therefore not a true illustration of what is living *in* or *on* the bottom, but a mixture mostly of epi-fauna from different communities, without giving the slightest idea of quantity per square metre. The content of a dredge and a bottom-sampler used on the same station will very often give quite different collections of animals.

The dredge has given excellent information to zoologists wishing to collect rare animals for preservation in alcohol, and for dredging oysters, and so on, but a true illustration of the fauna on the sea bottom it never has given and never will give.

I admit one thing: it is easy for me to speak and write about the bottom-sampler work, but it never will be well understood without seeing the work going on on board ship; many men of science from Europe have seen how quickly the sampler may be used, like an ordinary sounding machine, and how well it works. I should be glad to welcome many more visitors at the Danish Biological Station, not only to see the bottom-sampler working, but also to be able to discuss with them the problems which have arisen in my mind while using this method during the last 10 to 12 years.

It was a Dane, O. Fr. Müller, who first introduced

the dredge in northern Europe for scientific use, and it will always be used by zoologists and for special purposes, but only the bottom-sampler is able to give a true and quantitative representative illustration of the bottom fauna.

Finally, I wish to say that to have a bottom-sampler and to use it is not enough to become a great marine biologist; it depends much upon the possession of working ideas. The bottom-sampler is not able to solve every question; it cannot, e.g., take animals living very deep in a hard bottom, and the apparatus must be modified for special work, according to the size of the ship used, the depth at which you are working, etc., and it is necessary to supplement the investigation by means of other apparatus, fishing-gear, dredges, etc. But without quantitative work it is not possible to understand the principal features of the fauna of the sea-bottom.

It would be a matter of great scientific interest to have a bottom-sampler used down the slope of the continent at all depths, out on the very ocean floor, to determine all the communities living here, and to prove how barren the ocean floor really is. It would also be of great interest to follow our European communities from the North Pole down to Cape Town, to study their geographical distribution, to determine the perfectly unknown Arctic communities, and the unknown tropical communities. I have given a hypothetical chart in my Report No. 22, but it has to be verified. I am too old to do that, and my steamer too small. I hope other men will do it. I am sure the geologists would be glad to know something about these communities, based upon the common animals. I am certain that, like me, they care much more for common characteristic species and their distribution than for "rare" animals.

The productivity of the bottom fauna in European waters is by no means unlimited; it is, therefore, a matter of the greatest importance for some of the greatest fishery questions to know as much as possible about this productivity. The English fishermen are, as I often have heard, the backbone of the English navy; they depend upon the fishes, and these in turn depend upon the fish-food. Careful investigation of the latter is, therefore, a matter of great importance—particularly for Great Britain.

## Adhesives.

By EMIL HATSCHKE.

THE treatise of Theophilus Presbyter, entitled "Diversarum Artium Schedula," and well known to all students of the history of painting, gives directions for the preparation and use of glues from leather and deers' antlers, of plum- and cherry-gums, and of mixtures of cheese and lime described as "cheese glues." This list of adhesives familiar to craftsmen at the end of the eleventh century covers practically all the types in use at the beginning of the twentieth century. A similar degree of old empirical perfection is shown by many arts employing colloidal material, and the student of colloid chemistry anxious to magnify his office is perpetually confronted with the task of explaining the *rationale* of traditional procedure and of suggesting improvements based on theoretical grounds.

The difficulties of this task are well illustrated by the first report of the Adhesives Research Committee.<sup>1</sup> Towards the end of the war a shortage of glue and of the chief substitute, casein, threatened to limit the output of aircraft, and the labours of the committee

were accordingly directed, on one hand, to a close study of glue, and, on the other, to the discovery of possible substitutes other than casein. The report contains much interesting and novel matter under both heads.

The difficulties in the way of a rational study of glue seem to be twofold. The first is that the only criterion of its value as adhesive is a mechanical test of a glued joint between wooden test pieces of specified nature and size. The report describes the conditions of such a test, as finally adopted, and sets forth the possible sources of error. Both on theoretical and on practical grounds (about five days have to elapse from the soaking of the glue to the actual breaking test), it is desirable to find some easily measured constant which shows a simple quantitative relation with the breaking strength. No such constant is yet known, although empirically the setting time of the glue sol, the melting point of the gel and its "strength," *i.e.* roughly speaking, its modulus of elasticity, furnish some indication of its quality.

The second difficulty is of a more fundamental nature. It is known that pure gelatin is not a good

<sup>1</sup> Department of Scientific and Industrial Research. "First Report of the Adhesives Research Committee," pp. iv+129. Price 4s.

adhesive, so that the superiority of glue must be due, directly or indirectly, to the presence of other substances of which, so far, little is known. Investigations on this point are proceeding; in the meantime the committee have evolved a novel and highly promising test, that for "diffusible nitrogen." A gel of standard composition is immersed in a known volume of water, and after a fixed time the nitrogen content of the latter is determined by Kjeldahl's method. This is, of course, due to compounds of much lower molecular weight or aggregation than gelatin, and—apart from some exceptions—the amount of diffusible nitrogen is roughly inversely proportional to the tensile strength. While this result is of great interest, it can scarcely be said to simplify the problem stated above, namely, what factors cause the difference between pure gelatin and glue. Speaking, however, quite generally, we know of no connexion between constitution and adhesive properties; the striking fact is how sparingly the latter are distributed between a very few materials even among highly hydrated colloids.

Lack of space forbids detailed reference to the very interesting investigations on the extraction of gelatin from various raw materials, but the committee's successful attempt to find a strong vegetable adhesive

must be mentioned. A protein was prepared from castor bean residues—which are poisonous and therefore useless as cattle food—and this protein forms a strong adhesive with calcium hydroxide and alkaline salts in various proportions. From the data given regarding the solubility of this protein, it appears to be related to casein, and the mechanical properties of the adhesive prepared from it are not much inferior to those of casein glues.

The report is supplemented by an appendix—which greatly exceeds in length the report itself—giving a "Descriptive Bibliography of Gelatin." This is a very complete, lucid, and impartial summary of the vast literature, in which no paper of any interest seems to have been overlooked. Those from English sources—though important—are remarkably few in number, and this state of things suggests questions which are none the less curious for being familiar. One is whether the development of a very promising discipline is going to be left to workers of other nations as completely as was (to take an unacknowledged instance) that of the theory of functions; the other, whether such cases of neglect arise from deep-seated national tastes or idiosyncrasies in research, or merely from inadequate opportunities for tuition and experimental work.

### The Decomposition of Tungsten.

THE September issue of the Journal of the American Chemical Society contains an account of the preliminary experiments made by Drs. Wendt and Irion on the decomposition of tungsten at extreme temperatures, with the production of helium, a report of which appeared in the daily press, to which reference has already been made in NATURE (April 1, 1922, vol. 109, p. 418). The authors regret the exaggerated early report, given wide publicity by the press after its oral presentation, and emphasise the preliminary character of the work. They describe fully the apparatus used for attaining temperatures above 20,000° by passing heavy currents through metal wires, and state that when tungsten wires are exploded in a vacuum at such temperatures the spectrum of helium appears in the gases produced. When the explosion is conducted in carbon dioxide, 0.713 milligram of tungsten gave rise to 1.01 c.c. of gas not absorbed by potash solution. The authors remark that their method "includes factors, both of cause and of error, analogous to those operative in the voluminous and inconclusive controversy on the evolution of helium in various types of low pressure electrical discharge tubes, extending from 1905 to 1915."

The electrical apparatus provided for currents of 40 amperes at 100,000 volts during the brief period necessary to charge the condenser, which was then discharged through a tungsten wire 0.036 mm. diameter and 4 cm. long. The wires were stretched between heavy copper terminals in a special spherical glass bulb of 300 c.c. capacity, which was capable of

withstanding momentarily an enormous outward pressure, and had a small discharge tube sealed on for examination of the spectrum of any gas produced. The wire was heated to well above 2000° for 15 hours in a high vacuum before the explosion was made, and the tube before explosion showed no spectrum or fluorescence when connected with a 50,000-volt coil. No dust, smoke, or solid residue was left after the explosion. Gas was present, which showed the faint presence of the strongest green line of mercury, probably from back diffusion of the pumps, and the only other line uniformly present and positively identified was the strong yellow line of helium. It would seem that both hydrogen and neon were absent. The absence of hydrogen is of interest, since the atomic weight of tungsten is exactly 46 times that of helium, and this element would therefore not be expected to give hydrogen on disruption of its atom.

The explosion in carbon dioxide seems to have been less conclusive, as the authors do not seem to have been quite sure of the absence of unabsorbable impurities. They point out that if the entire weight of 0.713 milligram of tungsten had been converted into helium, 4 c.c. of this gas should have been obtained. The much smaller volume found would point to the production of heavier gases. Altogether the work is of very great interest, although the authors emphasise the necessity of complete analysis of the gas obtained before anything conclusive can be stated. This chemical test is to be made in the continuation of the work.

### The Belt of Political Change in Europe.

IN a paper contributed to Section E (Geography) of the British Association at Hull, Prof. J. F. Unstead commented on the striking fact that the new states of Europe, or those which have gained or regained independent existence during recent years, lie in a relatively narrow belt of country extending across the whole of Europe from the Arctic Sea in the north to the Mediterranean in the south. West of this belt changes have been slight, while east of it a final settlement has not been reached. Of this

belt no part has been exempt from change. It contains about 100 millions of people or about one-fifth of the inhabitants of Europe, and covers about one-fifth of the total area of the continent. The new states have been formed mainly by the break-up of three great empires, the disintegration of which was one of the results of the world war.

Prof. Unstead pointed out that the belt of change is a region caught between east and west, marginal to each and influenced by each, and he showed how

this idea applies both to physical and human conditions. Western Europe, with inland seas and intricate structure and relief, provides varied resources, maritime, agricultural, and mineral. Into this region spread the civilisation of the Mediterranean region, and here communities found the physical conditions which enabled them to develop. Physical barriers and relatively small productive areas gave distinctiveness and led eventually to the growth of separate nationalities. These nations became self-governing and, broadly speaking, democratic.

Eastern Europe, on the other hand, is characterised by uniformity of structure and relief, with great belts of similar climatic conditions and natural vegetation extending through it into Asia and so facilitating human migrations and military movements, mainly east and west. From the human as well as the physical point of view this region was for many centuries an extension of Asia and had but a scanty population. The Slav languages became characteristic and the authority of the Czar dominated the greater part of the region. The Asiatic incursions which in earlier centuries swept across the eastern plains were as a rule checked when they reached the belt of change. Here they found varied conditions of life, but different from those to which they had been accustomed. Traditions and names of invading tribes have been preserved, differences of language remain, and not infrequently feelings of hostility and memories of conquest are rife. Sufficient time has not yet elapsed for a complete fusion of races in the several regions of the belt. The Asiatic elements still assert themselves: Finns, Ests, Magyars, Bulgars, and Turks stand out, contrasted in one way or another with Swedes, Germans, Slavs, Albanians, and Greeks of European descent. Moreover, two small Nordic groups, Letts and Lithuanians, have preserved their identity from early times and remain distinct from other Nordic people in language and nationality. On the other hand, the occurrence of minerals has led to the partial penetration of Western influences.

Prof. Unstead went on to show the diversity of religion and political conditions in this belt of change. The problem of minorities exists in one form or another throughout the belt, and is perhaps the greatest menace to future peace. The present political units are by no means self-sufficing, and their frontiers are frequently barriers to trade and hindrances to production. Furthermore, the attainment of political freedom has often been accompanied by a check to production, commerce, and prosperity.

### University and Educational Intelligence.

ABERDEEN.—Applications are invited for the Blackwell Prize, value 30 guineas, for an essay on "The Sculptured and Inscribed Stones of the North-East and North of Scotland." The essays, bearing a motto and accompanied by a sealed envelope bearing the same motto and giving the name and address of the writer, must reach the secretary of the university on or before January 1 next.

CAMBRIDGE.—Mr. J. Walton, St. John's College, has been appointed junior demonstrator of botany. Mr. F. A. Potts, Trinity Hall, has been reappointed demonstrator of comparative anatomy. Dr. A. B. Appleton, Downing College, Mr. D. G. Reid, Trinity College, Mr. A. Hopkinson, Emmanuel College, and Mr. V. C. Pennell, Pembroke College, have been reappointed demonstrators in anatomy. Dr. F. Roberts, Clare College, Mr. T. R. Parsons, Sidney Sussex College, have been reappointed demonstrators in physiology. Mr. G. V. Carey, Clare College, has

been appointed educational secretary to the Cambridge University Press.

A. J. Smith, Downing College, has been appointed University Frank Smart Student in Botany. The John Winbolt prize has been awarded to F. E. Smith, Sidney Sussex College.

LEEDS.—Mr. Lascelles Abercrombie, lecturer in poetry at Liverpool University, has been elected by the council of the University professor of English language and literature, in succession to Prof. Gordon, who was recently appointed to the Merton professorship of English literature at Oxford.

LONDON.—It was announced in NATURE of July 29, p. 166, that Mr. H. G. Wells had consented to offer himself as Parliamentary candidate for the University, at the invitation of the executive of the University Labour Party, upon the retirement of Sir Philip Magnus at the end of the present session of Parliament. At a general meeting of the party held on Friday, October 6, Mr. Wells was adopted as Parliamentary candidate as recommended by the executive.

It is announced that Mr. H. M. McCreath, head of the Agricultural Department, Seale-Hayne College, Devon, has been elected principal of the East Anglian Institute of Agriculture, Chelmsford.

A SITE consisting of nearly 20 acres has been presented by Mr. T. R. Ferens at a cost of about 10,000*l.* to the education authorities of Hull for the immediate purpose of providing accommodation for advanced technical departments. It is anticipated that a university college will be developed later on the site.

The distribution of geographical teaching in the universities of Europe is illustrated in a map which accompanies a paper by Mr. W. L. G. Joerg, in the *Geographical Review* for July, on "Recent Geographical Work in Europe." From this map it appears that more than 120 universities in Europe (excluding Russia and allied Soviet states) have provision for geography. Germany, Switzerland, and France are perhaps the best provided, but Great Britain does not fall far behind. In Balkan lands, geography is fairly well represented in Bulgaria and Yugo Slavia; Rumania has four universities offering geography, while Hungary and Czecho-Slovakia also have centres of instruction. On the whole, the new or reconstructed states of Europe show every indication of realising the importance of the subject. The only states in Europe which would appear to offer no university geography are Latvia, Lithuania, Albania, Greece, and Ireland.

DURHAM University has recently published a calendar for the year 1922-23 (price 3*s.* 6*d.* net), a useful compilation which serves as a guide to affairs in the University. The first half of the volume deals with the University as a whole; its officers, the regulations affecting conduct and degrees, as well as the subjects required for the latter and for various diplomas are given. A special section is devoted to the fellowships, scholarships, and prizes which are awarded by the University. The remainder of the calendar is divided into three sections referring to the Durham colleges, the College of Medicine, Newcastle-upon-Tyne, and Armstrong College, respectively. It should be noted that up to and including September 1923 the matriculation examination will continue to be held in Durham and Newcastle; after October 1923 the matriculation examination (Newcastle Division) will cease to be held. The new regulations for matriculation in the Newcastle colleges, which will then come into force, are given in detail. In a concluding section of the volume there is an alphabetical list of members of Durham University.



## Calendar of Industrial Pioneers.

**October 15, 1889.** Sir Daniel Gooch died.—An eminent locomotive engineer and industrial administrator, Gooch served an apprenticeship in Stephenson's works at Newcastle, and at the age of twenty-one became locomotive superintendent to the Great Western Railway. He invented the Gooch link gear, experimented on the resistance of the atmosphere to trains in motion, designed a self-registering dynamometer, and built many fine broad-gauge engines. After resigning his position, he played an important part in the establishment of telegraphic communication between England and America, and from 1865 to 1887 was chairman of the Great Western Railway.

**October 17, 1907.** Gustav Adolf Zeuner died.—Born in Chemnitz, November 30, 1828, and educated at the Mining Academy at Freiberg, Zeuner as a professor of engineering did important work at Zurich, Freiburg, and Dresden, while his writings were highly valued by engineers. He founded the German journal *Zivilingenieur*, and he was widely known for his works on value gear and on technical thermodynamics.

**October 18, 1903.** Gordon McKay died.—The most successful inventor of boot-sewing machinery, McKay, who was born in Massachusetts in 1818, made an immense fortune which he bequeathed to Harvard University for science professorships and laboratories.

**October 18, 1918.** Marcel Deprez died.—For nearly forty years Deprez devoted himself to the application of electricity to industrial purposes. He solved many of the problems connected with the transmission of high-tension electricity, invented the compound winding for dynamos and devised measuring instruments. From 1890 he was professor of industrial electricity at the Conservatoire des Arts et Métiers.

**October 19, 1749.** William Ged died.—The inventor of stereotyping, Ged was born in 1690 and became a goldsmith in Edinburgh. In 1725 he took out a patent for developing Van de Mey's idea of substituting for movable type solid plates cast from type, and four years later he endeavoured without success to introduce his methods in London. His subsequent career was one of disappointment, and he died in poverty.

**October 19, 1897.** George Pullman died.—Pullman, to whom the world owes the modern railway carriage, was born in 1831 in New York State, and in 1859 settled at Chicago, where he began experimenting on the construction of sleeping-cars, his first successful car, the "Pioneer," being built in 1863 at a cost of 3000l.-4000l. The Pullman Palace Car Company was founded in 1867; extensive works were laid out in 1879, and at the time of Pullman's death more than 15,000 men were employed in them. The sleeping-car was introduced into England in 1875.

**October 21, 1896.** James Henry Greathhead died.—Trained as a civil engineer under Barlow, Greathhead devised the "Greathhead" shield, which has since been extensively used for driving tunnels.

**October 21, 1902.** Sidney Howe Short died.—Regarded as one of the most brilliant electrical engineers of his day, Short was a native of Columbus, Ohio, where he was born, October 8, 1858. Educated at the Ohio State University, at the age of twenty he succeeded Mendenhall as professor of physics there, and two years afterwards removed to Denver, Colorado. Resigning his chair in 1885, he took up practical work and did pioneer work in connexion with electric railways. E. C. S.

## Societies and Academies.

SWANSEA.

**Institute of Metals, September 22.**—F. L. Brady: The structure of eutectics. An attempt has been made to correlate the micro-structure of solidified eutectics, mainly those between metals and metallic compounds, with the physical properties of the component metals. The surface tension of the molten metal and the cohesive force acting during crystallisation seem to be the main forces influencing the final structure. The eutectics examined fall into three classes: "globular," "lamellar," and "angular." The structures agree with what would be expected from theoretical considerations of the effects of surface tension and cohesion.—M. Cook: The antimony-bismuth system. The two metals form an isomorphous series of alloys. The liquidus curve is perfectly smooth and the solidus is horizontal at 270° C. up to 60 per cent. of antimony, after which it rises steeply to the freezing-point of antimony. Chill-cast and slowly cooled specimens reveal duplex structures, but with prolonged annealing—550 hours at 275° C.—the alloys become homogeneous. Twin crystals and peculiar banded effects were observed in some of the annealed specimens. Possibly the twin crystals are formed during solidification of the alloy by stresses due to expansion, and grew on annealing. The nature of the "bands" has not been definitely ascertained, though they are not considered to be slipbands.—A. Jefferson: The cause of red stains on silver-plated work. The Sheffield Silver Trade Technical Society appointed a committee to examine this subject. It was established experimentally that the red stain is caused by the indiscriminate use of rouge in the finishing and polishing processes, through the absorption of the rouge into the open pores of the heated surface, the heat being evolved by the friction of the hand or finishing "dolly."—Q. A. Mansuri: Intermetallic actions. The system thallium-arsenic. By thermal and microscopic analysis it was shown that thallium and arsenic do not act chemically with each other nor do they form solid solutions; they alloy in all proportions. Arsenic dissolves in molten thallium and lowers its freezing-point until a solution of 8.01 per cent. arsenic freezes at the eutectic temperature of 215° C. Then the freezing-points of the alloys rise gradually to 240° C. All alloys containing from 13 to about 40 per cent. arsenic begin to freeze at 240° C. and are made up of two layers—the upper layer rich in arsenic while the lower rich in thallium. Beyond 40 per cent. arsenic, to nearly pure arsenic, the solution is uniform and the two layers disappear. By heating such substances in evacuated, sealed glass tubes and applying the hot junction of the couple in close contact with the outside of the glass tube, the couple is almost as sensitive as when dipped in the molten substance.—F. Johnson and W. Grantley Jones: New forms of apparatus for determining the linear shrinkage and for bottom-pouring of cast metals and alloys, accompanied by data on the shrinkage and hardness of cast copper-zinc alloys. The shrinkage values of chill-cast copper-zinc alloys were higher in general than those obtained for sand-cast bars by previous investigators. Pure electrolytic metals were used, and most of the alloys were poured at a temperature interval of approximately 115° C. above their liquids, the mould being kept at a constant temperature by a jacket of water maintained at the boiling-point. The bottom-pouring apparatus has the advantage of (a) control of pouring temperature; (b) facility for registering temperature of metal; (c) absence of delay between attainment of required pouring-temperature and release of metal into the

mould; (d) control of rate of pouring; (e) exclusion of dross from stream of metal; and (f) mitigation of "zinc-fume." Uniformity of hardness was secured by annealing. For the annealed bars the Brinell curve showed an increase of hardness over the range 100 to 88 per cent. copper. From 88 to 72 per cent. copper hardness was constant, a slight fall setting in at about 72 per cent. copper and persisting to 63 per cent., at which point a rapid increase set in with the appearance of the  $\beta$ -constituent. With the exception of a small dip in the curve, between 53 and 50 per cent. copper, the increase is maintained to 45 per cent. copper. The changes of scleroscopic hardness with composition are similar but less pronounced. The hardening capacity of the  $\alpha$ -brasses under cold-work increases rapidly with increase of zinc up to a maximum near 75 per cent. copper. The rolled strips, after close annealing, were re-tested for hardness; the range of uniform hardness is slightly restricted and the succeeding fall (between 70 and 63 per cent. copper) is more pronounced.—F. W. Harris: The hardness of the brasses, and some experiments on its measurement by means of a strainless indentation. The theories generally advanced with regard to the connexion between hardness and internal constitution have been, in the main, substantiated. A slight maximum occurs in the middle of the  $\alpha$ -phase and a small depression in the  $\beta$ -phase. The "absolute" hardness for the series was compared with the Brinell hardness by means of curves.

## PARIS.

Academy of Sciences, September 11.—M. L. Maquenne in the chair.—L. Cuénot and L. Mercier: The loss of the faculty of flight in parasitic Diptera. The hypothesis generally admitted is that the atrophy of the wings is the result of non-usage connected with the parasitic mode of life. The authors give the results of a series of observations directly opposed to this view.—E. Merlin: A mobile space attached to a network.—P. Urysohn: Cantorian multiplicities. D. Riabouchinski: The equations of motion in two dimensions, of solids in a liquid with vortices.—Henri Villat: Plane vortex movements in a fluid containing solid walls.—M. Thiébaud: The composition of the iridescent marls. These marls contain three main constituents: carbonates (dolomite and calcite), a silicate which is not a clay, approaching celadonite and bravaisite in composition, and detritic elements with abundance of white mica and quartz.—W. J. Vernadsky: The problem of the decomposition of kaolin by organisms. In admixture with bacteria, diatoms developed well on a nutritive medium, containing no silica except combined silica in a colloidal clay. From these results it would appear that diatoms, either alone or in association with bacteria, can decompose the kaolin structure and set free alumina.—Cam. de Bruyne: Idioblasts and diaphragms in the Nymphaeace.—Marc Romieu: A method of selective coloration of the nervous system in some invertebrates. Details of the application of the benzidine-hydrogen peroxide reagent to the study of the nervous system of some invertebrates. The nerves are coloured blue; and the nervous system as a whole can be seen down to the smallest details.—Gabriel Bertrand and M. Mokragatz: The presence of cobalt and nickel in plants. The ashes from twenty species of plants have been analysed, the parts utilised as food being chosen for examination. Nickel has been found in all the plants examined in quantities between 0.01 milligram and 0.2 milligram per kilogram of fresh material; cobalt (0.005 to 0.3 milligram per kilogram) was found in all cases except oats and carrot.

## Diary of Societies.

MONDAY, OCTOBER 16.

FARADAY SOCIETY AND THE BRITISH COLD STORAGE AND ICE ASSOCIATION (at Institution of Civil Engineers), at 2.30, 4.45, and 7.45.—Discussion on the Present Position of the Generation and Utilisation of Cold.—Prof. H. Kamerlingh Onnes and others: Laboratory Methods of Liquefaction, and Methods of Measuring Low Temperatures.—Dr. Crommelin: Description of the Equipment of the Cryogenic Laboratory at Leyden.—M. Claude: The Industrial Manufacture of Hydrogen by the Partial Liquefaction of Water Gas.—E. A. Griffiths and others.

CHEMICAL INDUSTRY CLUB (at 2 Whitehall Court), at 8.—Annual General Meeting.

ROYAL GEOGRAPHICAL SOCIETY AND THE ALPINE CLUB (at Central Hall, Westminster), at 8.30.—Gen. Bruce, Col. Scott, Mr. Mallory, Capt. Finch, and Major Norton: The Mount Everest Expedition, 1922.

TUESDAY, OCTOBER 17.

ROYAL HORTICULTURAL SOCIETY, at 3.—R. G. Hutton: The Control of the Fruit Tree by its Roots.

ROYAL SOCIETY OF MEDICINE, at 5.—General Meeting of Fellows.

INSTITUTE OF TRANSPORT (at Institution of Electrical Engineers), at 5.30.

ROYAL PHOTOGRAPHIC SOCIETY OF GREAT BRITAIN, at 8.—Major F. C. V. Laws: The Progress of Aerial Photography.

WEDNESDAY, OCTOBER 18.

ROYAL COLLEGE OF PHYSICIANS, at 4.—Dr. A. Chaplin: Harveyan Oration.

INSTITUTE OF PHYSICS (at Institution of Electrical Engineers), at 6.—C. C. Paterson: The Physicist in Electrical Engineering (Lectures on "Physics in Industry," No. 3).

ROYAL MICROSCOPICAL SOCIETY, at 8.—Prof. R. Chambers: New Apparatus and Methods for the Dissection and Injection of Living Cells.—T. F. Connolly: The Specification of a Medical Microscope.—H. J. Denham: A Micrometric Slide Rule.

THURSDAY, OCTOBER 19.

ROYAL SOCIETY OF MEDICINE (Dermatology Section), at 4.30; at 8.30.—Dr. Navatard: Epithelioma of the Skin.

ROYAL AERONAUTICAL SOCIETY (at Royal United Service Institution), at 5.30.—J. D. North: The Metal Construction of Aeroplanes.

INSTITUTION OF MINING AND METALLURGY (at Geological Society), at 5.30.

CHILD-STUDY SOCIETY (at Royal Sanitary Institute), at 6.—Dr. F. H. Hayward: Something Wrong with Intelligence Tests.

CHEMICAL SOCIETY, at 8.—Prof. T. M. Lowry: The Polarity of Double Bonds.—An Extension of the Theories of Lapworth and Robinson.

SOCIETY FOR CONSTRUCTIVE BIRTH CONTROL AND RACIAL PROGRESS (at Essex Hall), at 8.—Dr. Marie Stopes: The Ideals and Present Position of Constructive Birth Control (Presidential Address).

FRIDAY, OCTOBER 20.

INSTITUTION OF MECHANICAL ENGINEERS, at 6.—Dr. H. S. Heleshaw: Presidential Address.

JUNIOR INSTITUTION OF ENGINEERS, at 7.30.—G. H. Ayres: Profits from Waste Products.

INSTITUTION OF PRODUCTION ENGINEERS (at Royal Automobile Club), at 8.—M. H. Lawrence: Presidential Address.

ROYAL PHOTOGRAPHIC SOCIETY OF GREAT BRITAIN, at 8.—G. A. Clarke: Record Work in Cloud Photography.

## PUBLIC LECTURES.

SATURDAY, OCTOBER 14.

HORNIMAN MUSEUM (Forest Hill), at 3.30.—H. Shaw: Flight in all Ages.

MONDAY, OCTOBER 16.

ROYAL COLLEGE OF SURGEONS OF ENGLAND, at 5.—Prof. Shattock: The Anatomical Results of Inflammation.

CITY OF LONDON Y.M.C.A. (186 Aldersgate Street), at 6.—Dr. E. L. Ash: Mind and Health.

TUESDAY, OCTOBER 17.

GRESHAM COLLEGE (Basinghall Street), at 6.—A. R. Hinks: Astronomy. Succeeding Lectures on October 18, 19, 20.

WEDNESDAY, OCTOBER 18.

SCHOOL OF ORIENTAL STUDIES, at 5.—J. W. Robertson Scott: Impressions of the Japanese.

UNIVERSITY COLLEGE, at 5.30.—Sir Richard Paget, Bart.: The Nature and Reproduction of Speech Sounds.

THURSDAY, OCTOBER 19.

UNIVERSITY COLLEGE, at 4.—Dr. T. G. Pinches: Babel and its Gods. CITY OF LONDON Y.M.C.A. (186 Aldersgate Street), at 6.—Sir D'Arcy Power: Surgery in the City of London.

FRIDAY, OCTOBER 20.

ROYAL COLLEGE OF SURGEONS OF ENGLAND, at 5.—Sir Arthur Keith: Hydrocephaly.

BEDFORD COLLEGE FOR WOMEN, at 5.30.—F. H. Marshall: The Early Civilisation of Ionia.

SATURDAY, OCTOBER 21.

HORNIMAN MUSEUM (Forest Hill), at 3.30.—Miss M. A. Murray: The Nile in the Life and Religion of the Ancient Egyptians.

# NATURE

A WEEKLY ILLUSTRATED JOURNAL OF SCIENCE.

*"To the solid ground  
Of Nature trusts the mind which builds for aye."*—WORDSWORTH.

No. 2764, VOL. 110]

SATURDAY, OCTOBER 21, 1922

[PRICE ONE SHILLING

Registered as a Newspaper at the General Post Office.]

[All Rights Reserved.]

## NEWTON'S (New Model) "DEMONSTRATOR'S" LANTERN

For all classes of  
Projection Work.

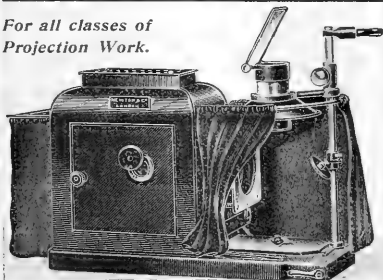

Price List sent on application.

NEWTON & Co., 72 Wigmore St., London, W.1.  
(Specialists in Optical Projection Apparatus.)

## CHEMICALS

Analytical, Technical and A.R.

RECD. TRADE MARK

### APPARATUS



### BENCHES

Balances

Fume Chambers, etc.,

for

Chemical, Physical, and  
Technical Laboratories.

A SNOW CRYSTAL

Price Lists and Estimates on Application.

## REYNOLDS & BRANSON, LTD.,

Contractors to the War Office, Admiralty and  
Egyptian Government, &c.

14 COMMERCIAL STREET, LEEDS.

**BAIRD & TATLOCK (LONDON) LTD.**

SCIENTIFIC INSTRUMENT MANUFACTURERS  
and LABORATORY FURNISHERS.

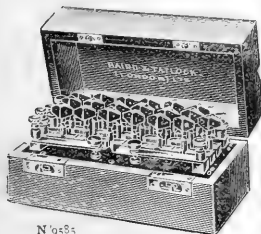

N 955  
RESISTANCE BOX

Physical  
Apparatus  
for  
Schools  
and  
Colleges.

14-15 CROSS STREET HATTON GARDEN LONDON E.C.1



CERTIFICATE  
— OF —  
EXAMINATION

OF  
Fahrenheit Thermometer No. 11550, etc.

Name of Thermometer — Nagretti & Zambra

Certificates to be issued to the Scale Readings determined by comparison with the  
Standard Thermometer at the National Physical Laboratory, Reading. The correct one  
is given in the margin. — 1922

READING	DIFFER. IN
F.	C.P.
30.0	0
40.0	0
50.0	0
60.0	0
70.0	0
80.0	0
90.0	0
100.0	0

Note I.—When the sign of the correction is + the quantity must be added to the observed value indicated  
and when the sign is - it must be subtracted.

Note II.—The instrument when in the Scale is subject to an error of 0.1° at the top of the scale.

Note III.—If the instrument is not used, it may be returned to the manufacturer for a certificate of approval on the  
completion of the instrument. For the correct certificate, the instrument must be returned with the  
same precautions as when it was first issued. — 1922

Done 11th July 1922.

Attest: Chas. W. De Laet.

NEGRETTI & ZAMBRA

NEGRETTI & ZAMBRA

**FINSBURY TECHNICAL COLLEGE.**

LEONARD STREET, CITY ROAD, E.C.2.

**STREATFEILD MEMORIAL LECTURE.**

The fifth annual Lecture will be delivered by Professor CECIL H. DESCH, D.Sc., Ph.D., F.I.C. (the University of Sheffield), in the Chemical Lecture Theatre of the College, on Thursday, November 2, 1922, at 4.15 P.M. Subject: "THE METALLURGICAL CHEMIST." A. CHASTON CHAPMAN, Esq., F.R.S., President of the Institute of Chemistry, will preside.

**UNIVERSITY OF LONDON.**

A Course of eight Lectures in Physiology on THE HISTOLOGY OF THE NERVOUS SYSTEM will be given by DR. C. DA FANO, at KING'S COLLEGE (Strand, W.C.2.) on WEDNESDAYS, October 25; November 1, 8, 15, 22 and 29; and December 6 and 13, 1922, at 4.30 P.M. ADMISSION FREE, WITHOUT TICKET.

EDWIN DELLER, Academic Registrar.

**TO SCIENTISTS, RESEARCH STUDENTS, AND SCHOLARS.****THE INTERNATIONAL BIBLIOGRAPHICAL SERVICE BUREAU**

supplies complete Continental and American bibliographies on any scientific, literary, or medical subject. Chemical work a speciality. Extracts made. Headquarters: Vienna. English representative: "ALEXANDRIAN," 1A Longridge Road, Earl's Court, S.W.5.

**LEEDS GRAMMAR SCHOOL.**

The GOVERNORS invite applications for the Post of HEADMASTER of this School.

The School is a Day School. Present Numbers, 600.

Advanced Courses in Classics, and in Mathematics and Science.

Applicants must hold Honours Degrees of a University in the United Kingdom or the British Dominions.

Salary £1200, rising by annual increments of £50 a year to £1500.

House free of rent, rates, and external repairs provided.

Duties to begin as from January 1, 1923.

Applications, with references and 20 copies of not more than 3 recent testimonials, to be sent in so as to be received not later than October 31, 1922, to the CLERK TO THE GOVERNORS, 6 Butts Court, Leeds.

**UNIVERSITY OF BRISTOL.****DEPARTMENT OF AGRICULTURAL AND HORTICULTURAL RESEARCH, LONG ASHTON.**

Applications are invited for the post of ADVISOR in ECONOMIC ENTOMOLOGY. Particulars of the appointment may be obtained from the undersigned, to whom applications, together with copies of three recent testimonials, should be addressed not later than October 26, 1922.

JAMES RAFTER, M.A., Registrar.

**UNIVERSITY OF DURHAM.****ARMSTRONG COLLEGE, NEWCASTLE-UPON-TYNE.****LECTURER IN ELECTRICAL ENGINEERING.**

APPLICATIONS are invited for the above post. Salary £300 per annum. Appointment for one year which may be extended.

Duties to commence as soon as possible. Last date for application, October 30. Further particulars may be had on application to the REGISTRAR, Armstrong College.

**VICTORIA COLLEGE, WELLINGTON, NEW ZEALAND.**

Applications are invited for the position of PROFESSOR OF PHYSICS at the above College at a salary of £750, rising to £850, per annum.

Full particulars obtainable by sending stamped or foolscap envelope to the HIGHT COMMISSIONER FOR NEW ZEALAND, 415 Strand, London, W.C.2, by whom applications will be received up to October 28, 1922.

**CHESHIRE COUNTY COUNCIL.**

Applications are invited for the post of LECTURER in BIOLOGY at the Cheshire School of Agriculture, Reaseheath, Nantwich. Salary £250 per annum (with board lodging) according to experience.

Particulars and forms of application (to be returned by November 1, 1922) from PRINCIPAL, Cheshire School of Agriculture, Reaseheath, Nantwich.

F. F. POTTER, Director of Education.

**LIVERPOOL COLLEGE.****HUYTON, near LIVERPOOL.**

WANTED, in January, SCIENCE MISTRESS. Botany and Zoology up to London H.S.C. standard. Salary Burnham Scale for eight years, £75 deducted for residence. Board of Education Pensions. Apply Head Mistress.

**BRITISH MYCOLOGICAL SOCIETY.**

A series of three lectures by

PROFESSOR A. H. R. BULLER, Ph.D., F.R.C.S.,

Professor of Botany at the University of Manitoba,

will be given on "STUDIES IN THE MORPHOLOGY AND PHYSIOLOGY OF FUNGI" in the Botany Department, University College, Gower Street, W.C.1, at 5 P.M.

Friday, October 20.

1. "Pilobolus and the Ocellus Function of its Subsporangial Swelling."

Friday, October 27.

2. "Sex and Social Organisation in the Hymenomyceses."

Friday, November 3.

3. "The Production and Liberation of Spores in the Genus Coprinus."

Admission without ticket.

**THE UNIVERSITY COLLEGE OF SOUTHAMPTON.****LECTURESHIP IN MATHEMATICS.**

The Council invites applications for a LECTURER in MATHEMATICS (male). Salary £300, subject to University Teachers' Pension Scheme. Applications with testimonials should be sent before October 30 to the REGISTRAR, from whom further details may be obtained.

The Candidate elected will be required to enter upon his duties in January.

**SCIENTIFIC INSTRUMENT MAKER**

DESIRES POST in Laboratory or Institute on Instrument or Experimental work. Indentured Apprentice, 20 years' experience in analysing, scientific and surveying instruments. 13 years' reference late employer, 3 years' Indian Government. Write Box 21/22, c/o NATURE Office.

**CHEMIST, B.Sc. (Lond.), 1st Class Hons.,**

desires post. Home or Abroad. Box 22, c/o NATURE Office.

**AUTHORS' TYPIST.—4th year Chemical**

Student undertakes typing of scientific papers, authors' MSS., etc. Good knowledge of French and German. Box 10, c/o NATURE Office.

**FOR SALE: "Nature" vols. 63 to 109;**

"Zeitschr. Wiss. Photographie," vols. 1-13; Winkelmann, "Handb. d. Physik," 2nd Ed., 7 vols.; Eder and Valenta, "Beitrag zur Photochemie u. Spektralanalyse," and others. Offers or inquiries to Box 4572, c/o NATURE Office.

**BACTERIOLOGICAL INCUBATOR,**

HEARSON'S, in good working condition, with patent Gas Regulator, FOR SALE, inside measurement 15" x 15" x 18", supplied by Messrs. Baird & Tatlock. Inspection and offers invited. PROPAGANDA MANAGER, S/Ammonia, 30 Grosvenor Gardens, S.W.

**PHILOSOPHICAL MAGAZINE: what**

offers for numbers, April 1918-September 1922? Unbound. Good condition. Box 2764, c/o NATURE Office.

**ACCURATE CHEMICAL THERMOMETERS.—**

110° C., 150° C., 250° F., 300° F., 225; 200° C., 225.64; 350° C., 400° F., 32; 500° C., gas-filled, special glass, 102; Beckmann Thermometers with Auxiliary Scale, 1/10 C., 775. 6/2, each.—CHELSE, Chesham.

**The Misses FARRAN**

10 Bell Yard, Temple Bar, W.C.2,

HAVE CONSIDERABLE EXPERIENCE IN

**COPYING SCIENTIFIC MS.**

AND ARE PREPARED TO UNDERTAKE ANY QUANTITY.

IF any difficulty is experienced in obtaining NATURE from Booksellers or Newsagents, Orders, with remittance, should be sent to the Publishers.

\* \* For Subscription Rates see p. cxxxv of the current issue.

Office of NATURE, St. Martin's St., W.C.2.



SATURDAY, OCTOBER 21, 1922.

CONTENTS.

	PAGE
Sex Economics. By Barbara Wootton . . . . .	533
Fishing and Fishing Lore. (Illustrated.) By Henry Balfour . . . . .	534
The Metallurgy of Iron and Steel. By Prof. C. H. Desch . . . . .	537
The Snakes of Ceylon. By E. G. B. . . . .	538
Japanese Social and Economic Life . . . . .	538
Hull and the East Riding. By W. E. C. . . . .	539
Our Bookshelf . . . . .	540
Letters to the Editor :—	
Mersenne's Numbers.—Prof. G. H. Hardy, F.R.S. . . . .	542
Animal Mechanism.—H. S. Rowell . . . . .	542
Vegetable Rennet.—Prof. R. Hedger Wallace . . . . .	543
A Question of Nomenclature.—F. H. Masters . . . . .	543
Capillarity.—R. M. Deeley . . . . .	543
Lead and Animal Life.—Miss K. Carpenter . . . . .	543
Polar and Non-Polar Valency in Organic Compounds.—W. E. Garner . . . . .	543
The X-ray Structure of Potassium Cyanide.—P. A. Cooper . . . . .	544
Sex Change in Mollusca.—Prof. J. Brontë Gatenby . . . . .	544
The Galactic System.—I. By Dr. Harlow Shapley . . . . .	545
Transport of Organic Substances in Plants. By Prof. H. H. Dixon, Sc.D., F.R.S. . . . .	547
Obituary :—	
Colonel E. H. Grove-Hills, C.B.E., C.M.G., F.R.S. By H. G. L. . . . .	551
Major-General J. Waterhouse . . . . .	552
Current Topics and Events . . . . .	553
Our Astronomical Column . . . . .	555
Research Items . . . . .	556
Tendencies of Modern Physics . . . . .	558
The Isothermal Frontier of Ancient Cities . . . . .	558
The Mechanism of the Cochlea . . . . .	559
British Association Research Committees . . . . .	560
University and Educational Intelligence . . . . .	561
Calendar of Industrial Pioneers . . . . .	562
Societies and Academies . . . . .	563
Official Publications Received . . . . .	564
Diary of Societies . . . . .	564

Editorial and Publishing Offices :

MACMILLAN & CO., LTD.,

ST. MARTIN'S STREET, LONDON, W.C.2.

Advertisements and business letters should be addressed to the Publishers.

Editorial communications to the Editor.

Telegraphic Address: PHUSIS, LONDON.

Telephone Number: GERRARD 8830.

NO. 2764, VOL. 110]

Sex Economics.

IN his presidential address to the Section of Economics of the British Association at the recent meeting at Hull, Prof. F. Y. Edgeworth did not hesitate to plunge into the midst of a raging current controversy. "Should men and women receive equal pay for equal work?" were his opening words, and his conclusion is that they should "with some reservations and adjustments."

This conclusion is reached in two stages as follows. In a first approximation Prof. Edgeworth relegates dependants to limbo, and shows—we think conclusively—that, granted that freedom of competition for jobs is generally conducive to the best possible distribution of labour, then there is no reason why such competition should be confined to one sex; though it must be a regulated competition, controlled by collective bargaining, in which "the oppressive action of male Trade Unions" is "counteracted by pressure on the part of women acting in concert." The overcrowding of women into those occupations which are open to them, which has resulted from restrictions upon their freedom to compete on equal terms with men in all spheres, is in fact socially uneconomic as well as unfortunate in its effect upon the women's own wages. Prof. Edgeworth goes on to surmise that given substantial freedom of competition we shall find (a) occupations almost wholly male, (b) occupations into which both men and women enter freely, and (c) occupations almost wholly female. He submits that the average of weekly earnings in (a) will continue to be above the average of weekly earnings in (c), while in (b), though the rate of pay for a unit of work will be the same for both sexes, the average weekly earnings of the male will continue to be above the average weekly earnings of the female.

Prof. Edgeworth does not offer any particular evidence of these suggestions, which rest upon an assumption that at present, or rather "for a short period in the immediate future," the industrial efficiency of women must be generally inferior to that of men. In point of fact, practically no scientific investigation has yet been made of the relative efficiency of men and women in different occupations. Nor, in view of the close and long-standing restrictions upon the field of women's labour, does the actual distribution of the sexes between different occupations throw much light upon the problem. In quoting the usual examples of telephony, typewriting, textiles, and nursery duties as the female *fortes*, Prof. Edgeworth seems to be allowing convention rather than science to be his guide.

Wise advocates of women's rights will, however,

agree with Prof. Edgeworth when he points out where other things are equal an employer is likely to have a preference for the male owing to the "secondary" drawbacks of the female. Prejudice and restricted opportunities may be responsible for what truth there is in the charge that "a woman is not so useful in the case of a breakdown or a runaway." But it is quite indisputable that the probability of her early marriage is a real drawback to a woman's industrial efficiency. These secondary differences, however, are so difficult to measure accurately that the reduction on their account of the woman's rate per unit of work below that of the man is not a wise or scientific policy. It is better to allow them to make their influence felt upon the occupational distribution of the sexes rather than upon their pay. Of the "tertiary" differences also (of which the illustration given is "the presence and influence of a master—as contrasted with a mistress—in dealing with the bigger boys") the same is true; but there is no evidence to show whether these tertiary differences predominantly favour the male rather than the female.

We now restore the abstracted circumstances of family life. A man normally has, or expects to have, a family to support; a woman normally has not. While the average number of dependants supported by a woman from her earnings has often been greatly underestimated, there is certainly no disputing the general result of Messrs. Rowntree and Stuart's figures, which show that this average is much higher for a man than for a woman. The candid will admit that here is the real obstacle to equal pay for equal work; the logical will consider the possibilities of endowment of motherhood as a way out of the difficulty. Prof. Edgeworth summarises the *pros* and *cons* of State endowment of motherhood as follows. The proposal is attractive because (1) it would for the first time make competition between the sexes both free and fair; and (2) it would make possible the distribution of resources in such a way as to meet the requirements of the larger family better than is done at present, when the wage paid to a man tends to be adjusted to the presumption that he maintains a family of approximately 4.4 persons, which he quite certainly does not. Against these advantages Prof. Edgeworth sets the following: (1) the scheme is socialistic and bureaucratic, (2) it would almost certainly involve a transference of resources from the rich to the poor and would therefore probably check saving, (3) the effect on the contributor would be "depressing," and there would be (4) a great stimulus to population, and (5) no security for the improvement of the race, but only a prospect of "the ruin of the great middle class to which England owes so much."

We gather that Prof. Edgeworth regards these disadvantages as conclusive. He turns from the State endowment of motherhood to consider one or two other suggestions, the principal of which is his own proposal that the members of Trade Unions might themselves contribute a quota of their earnings to a fund to be distributed among the wives of members in accordance with the size of their families. In regard to this proposal Prof. Edgeworth does not commit himself beyond the canny statement that it would be much less open to objections than the endowment of motherhood by the State.

Prof. Edgeworth's address is open to little criticism from those who grant his premises. All will applaud his careful analysis of his subject. It is, however, at least open to question whether his whole treatment of the matter does not suffer immensely from the limitations which he has imposed upon himself. In his first approximation the assumption that "regulated competition" (a very vague concept) is a royal road to ideal distribution is open to serious criticism. Secondly, any discussion of endowment of motherhood which assumes outright that (a) transferences of resources from rich to poor would be entailed, and that (b) these are objectionable, rests on questionable ground. To the present writer this double assumption appears fatal to Prof. Edgeworth's conclusions regarding the right relation of the basis of payment to family circumstances.

BARBARA WOOTTON.

### Fishing and Fishing Lore.

*Fishing from the Earliest Times.* By W. Radcliffe. Pp. xvii + 478. (London: J. Murray, 1921.) 28s. net.

THE literature connected with fishing is already so extensive that a new volume is liable to be subjected to scrutiny to see whether it can justify its birth by furnishing new matter or new ideas. As the more obvious gaps in the literature of the subject become fewer, the tests will necessarily become more searching. Mr. Radcliffe's book, fortunately, can claim a definite *raison d'être*, and may receive an enthusiastic welcome as filling a decided gap, one which it is curious should have so long remained void. His aim has been to provide a history of the fishing art and craft from the earliest times down to about A.D. 500. The title scarcely does justice to the contents of this versatile volume, which is far from being restricted to the consideration of actual fishing practices. These, indeed, probably occupy but a third of the book. The remainder is very largely concerned with what may be classed as the folk-lore associated with fish, fishing, fishermen, and fish-consumers, and with other details

which are by-products of the industry. Mr. Radcliffe has been at great pains to bring together a great mass of material which he has collated and coaxed into a very readable form. The illustrations are both good and numerous. The result is an important work which is both entertaining reading, and of considerable value as a comprehensive book of reference. In the main, it consists of classified quotations which are analysed and evaluated by the author. One would gather that the author has thoroughly enjoyed his self-imposed task. He revels in argument, and while now and then he may, perhaps, be suspected of "special pleading," his interpretations of doubtful or obscure passages are always interesting and suggestive, even when he fails to be entirely convincing.

The introduction extends over sixty pages and deals with a number of points of general interest and with early prehistoric fishing. For our knowledge of fishing practices during the Stone and Bronze Ages we are dependent upon evidence which is, unfortunately, meagre in amount, and requires much speculation for the completion of the picture. Mr. Radcliffe has not made an intensive study of fishing as practised by recent Stone-age peoples, and he makes but slight use of the evidence which they can afford, valuable though it may be for the light which it can throw upon the archaeological record. Ethnological data must be brought to bear upon archaeological research if an adequate diagnosis of early customs and appliances is to be achieved.

A comprehensive work dealing with fishing pursuits and methods among the recent "unrisen" peoples, the progress of whose more or less primitive culture has been arrested or retarded at various stages of advancement, still remains to be written. When such a work, based upon comparative study, is available, archaeological commentarists will find a valuable ally which will assist materially in their interpretations of ancient data.

The present volume would have gained by a wider reference to evidence derived from ethnological sources, and some of the problems with which Mr. Radcliffe deals so interestingly might have been more convincingly attacked or solved. Mr. Radcliffe takes especial delight in tracing the earliest references to various fishing-appliances. [See Figs. 1 and 2 here reproduced by the courtesy of the publishers.] To Martial he assigns the first mention of the jointed rod

(*crecensc harundo*), and of fishing with a fly; but to Ælian the first definite reference to the use of an artificial fly. In dealing with the latter, he appears to be convinced that the artificial fly of those days was an imitation, as close as possible, of a natural fly; but this view does not seem to be borne out by Ælian's description, which rather suggests the reverse, i.e. a type of lure which was a novelty to the fish, which were attracted by its unusual gaudiness. Aristotle is given credit as the first "scale-reader" in estimating the age of fishes. There seems to be a zoological confusion when Mr. Radcliffe uses evidence from two passages, one of which refers to the scales of fish which afforded an indication of age, while the other relates to the growth indications upon the shell of a Murex (a mollusc). But zoological differentiation is

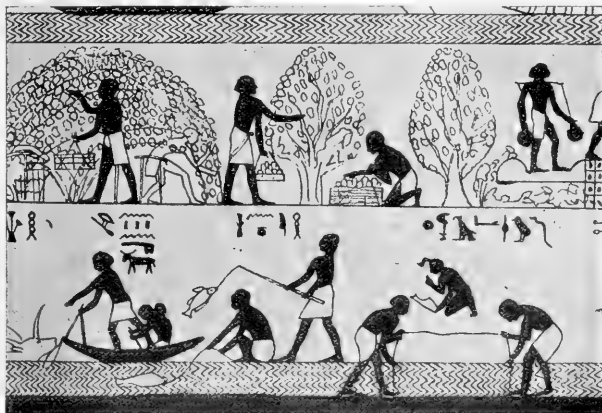

FIG. 1.—The earliest representation of angling, c. 2000 B.C. From "Fishing from the Earliest Times."

scarcely Mr. Radcliffe's strong point, and he apparently is convinced that dolphins are to be classed with the fishes (pp. 91, 92, 95, 165, 450, etc.), and this in spite of the fact that Aristotle, whom he quotes, recognised essential differences between fish and cetacean mammals. The plate opposite p. 180 is described as illustrating a "pattern of Torpedo fish"; but the three fishes represented clearly belong to three distinct varieties, all of them *bony* fishes, whereas the Torpedo fish (a kind of ray) belongs to the group of *cartilaginous* fishes. Again, on p. 414, he includes shell-fish among the fishes prohibited by Moses, without any covering comment. These "termino-zoological inexactitudes" tend somewhat to obscure the scientific status of the book.

A time-honoured controversy is revived and reviewed in detail in chapter 2, where the author deals with the various interpretations of the function of the ox-horn (*κερας βοδης αγριουλοι*) referred to in the "Odyssey"

(xii. 251 ff.) and "Iliad" (xxiv. 80 ff.) in connexion with similes derived from fishing processes. The varied theories are quoted and evaluated with skill, and the author himself inclines toward the suggestion of C. E. Haskins, namely, that the *képas* was an artificial bait of horn. This controversy has been carried on in the pages of the *Times* Literary Supplement, in reviews of the book, and in letters arising therefrom. The whole discussion, however, leaves one unconvinced and still wondering. Since the controversy still remains "fluid," I am tempted to offer yet another

dragging after it the line; the water-resistance causes the bell-like carapace to slip along the line as far as the stop, so that it covers and protects the baited hook as it is carried downward through the weed stratum. Since the carapace is very light it probably floats away from and uncovers the bait when the line becomes stationary at the desired depth. Similarly, as the line is drawn in the resistance of the water drives the bell down over the hook and again protects it on the upward journey. Now, substitute a selected bell-shaped ox-horn for the crab's carapace and a slightly more efficient form of this apparatus is devised, which should serve the same purpose admirably.

The merit, if any, of my suggestion is derived from the following facts, (1) that the apparatus which affords a seeming clue to the function of the *képas* is an actual one still in practical use locally, and is very possibly a survival from an ancient type formerly far more widely employed; (2) that the much-debated "resounding splash" (cf. *στοιβάχησε δὲ λίμνη* in the Iliad passage) is plausible as a description of the effect produced by casting such an apparatus into the sea; (3) that it is consistent with fishing from a headland on a rocky and weedy coast such as, I believe, is characteristic of southern Italy and of the region lying between Samos and Imbros, the areas to which Homer's two similes are applied; (4) that it conforms with the picturesque description of the dive of Iris when she "sped to the bottom like a weight



FIG. 2.—The happy fisherman, attributed to the artist Chachrylion. From "Fishing from the Earliest Times."

possible solution, to take its chance with those previously offered. Line-fishers on the coast of Western Ireland employ a very simple and ingenious contrivance to overcome the difficulty which arises from their hooks becoming entangled in seaweed, when fishing is pursued in rock-studded waters. It is desired to sink the baited hook below the level of the weed layer, and the problem is to pass it through the tangled and entangling mass. To achieve this, at a short distance above the hook there is attached to the line a crab's claw, which serves as a stop. Still farther up the line a weight (or sinker) of lead or stone is fastened, and between the stop and the weight an empty carapace of a crab is loosely threaded upon the line, so that it can slide along the latter between the sinker and the stop. When the line is cast out by the fisherman, the weight descends first,

of lead, that mounted on the horn of a field-ox goeth down, bearing death to the ravening fishes"; (5) that the *képas βoδὸς ἀγραύλοιο* which some commentators aver must imply the whole horn, and not merely an object made of horn, would, for the purpose I have suggested, have been practically entire, so that the hook could be withdrawn into its protecting cavity. A small hole drilled in the apex (through which to pass the line) would be the only essential modification required. The expression "mounted on the horn" alone offers some difficulty; "near" or "with" instead of "on" would certainly have added weight to my suggestion.

The problems suggested by or dealt with in this book are numerous, and Greek, Roman, Egyptian, Assyrian, Jewish, and Chinese fishing methods and fishing lore



all receive detailed and careful treatment. The author has brought to bear upon his task the experience of a practical and enthusiastic angler, and the zest of a keen student. While he realises the more serious aspects of his theme, he has dealt kindly by the general reader and writes in a light-hearted, attractive, and unpedantic manner. In this way he should be instrumental in developing a wider interest in and stimulating further research into the history of one of the oldest industries, and has given us the story of progress from a humble and despised craft to a popular and respected art.

HENRY BALFOUR.

### The Metallurgy of Iron and Steel.

(1) *Engineering Steels*. By Dr. L. Aitchison. (Reconstructive Technical Series.) Pp. xxxi+348+48 plates. (London: Macdonald and Evans, 1921.) 25s. net.

(2) *The Case-Hardening of Steel: An Illustrated Exposition of the Changes in Structure and Properties induced in Steels by Cementation and Allied Processes*. By H. Brearley. Second edition. Pp. xi+207. (London: Longmans, Green and Co., 1921.) 16s. net.

(3) *Iron-Founding*. By B. Whiteley. (Pitman's Common Commodities and Industries.) Pp. 131. (London: Sir I. Pitman and Sons, Ltd., 1921.) 3s. net.

(1) THE advance of metallurgy in recent years has placed at the disposal of the engineer a wide range of new materials, including alloy steels which so far surpass the older, plain carbon steels in strength and toughness as to constitute a new class of metals. In the face of such diversity the engineer finds difficulty in selecting the most suitable material for a given purpose, and is not in a position to judge between the products offered by manufacturers, or recommended by specialists. There are in existence many excellent memoirs and a few books on the subject, but they are written for the metallurgist, and assume a technical knowledge that lies outside the usual field of study of the engineer. It is highly desirable that the user of a metal should understand its properties as well as the maker, and Dr. Aitchison has made the attempt, largely successful, to describe the steels now available for engineering purposes, without assuming a knowledge of chemistry or metallurgy.

The title of Dr. Aitchison's book must be interpreted in a rather restricted sense. The engineer is interested in such steels as those used for ship and boiler plates, rails, and girders, but he will find little in reference to them, the work being mainly concerned with steels required by the automobile and aircraft industries. It is these steels of high tensile strength, often required

to withstand severe alternating stresses, that present the greatest difficulties of specification and testing, and it is very necessary that the information regarding them should be collected and placed clearly before the engineering user, as has been done here. There is a very brief account of methods of manufacture, sufficing to indicate the distinction between various classes of steel, and a discussion of ingot structure, so far as is required to explain the possible sources of defects in forgings.

It is probably on account of the limitation mentioned above that only piping steel is described, and the subject of blowholes is not mentioned. Steel castings are omitted entirely, although of great interest to the engineer who uses high tensile steel forgings for other parts of his machine. The desire to avoid chemical and metallurgical difficulties leads to a somewhat excessive simplification of the chapter on heat treatment, and the author's account of hardening and his explanation of the critical points is rather misleading, although not likely to cause misunderstanding of the practical instructions. It should be said that the style is easy and readable throughout.

The subject of mechanical testing is well treated, proper attention being given to the determination of the fatigue range and its relation to the other measurements usually made in the testing laboratory. Much of the experimental material in this chapter is taken from the author's reports to the Aeronautical Research Committee. His conclusions may not always be accepted, but the importance of the subject is rightly emphasised, and the descriptions of fatigue tests and the short accounts of other special methods of testing are valuable. There are very few references to original sources, but a full bibliography of papers relating to the determination of hardness is given.

The alloy steels are considered in detail, the properties of each steel, as modified by different heat treatments, being shown by means of diagrams similar to those published by the Automobile Steel Research Committee; these diagrams provide a useful guide to the characteristics of the various classes of steels. Case-hardening and cold-working are other subjects dealt with.

The book is very well printed and illustrated, many of the best plates being selected from Mr. Brearley's works, while others show special types of testing machines. The whole subject of the relative value of tests for steels of this class is in a state of flux, and an authoritative statement is not yet to be expected, but Dr. Aitchison has made a good beginning, and his efforts will be welcomed by engineers.

(2) The first edition of Mr. Brearley's book on case-hardening was published in 1914, and it is an indication

of its trustworthy character that scarcely any statement contained in it has had to be withdrawn in the preparation of the new edition. The subject-matter has been widened by the inclusion of further particulars concerning alloy steels of the class frequently employed in automobile construction, and by the addition of sections on specifications, in regard to which the author expresses decided opinions, based on a wide experience. The treatise is of more general interest to the metallurgist than might be assumed from its title, since the description of the materials and processes of case-hardening and of the defects that may occur in case-hardened objects, involves the discussion of many other points of importance in the treatment and use of steel. On all these subjects, the advice given is sound and admirably clear in its expression. Only two minor points have been noted for criticism. There is no mention of nichrome carburising boxes, although these are now frequently used, and justify by their long life the increased cost. Plating with copper, as a means of local protection against carburisation, is still spoken of as unsatisfactory, although it has been practised with great success in the construction of aero-engine parts.

(3) The third work on our list is an elementary handbook on iron-founding. It contains a simple description of foundry methods, and the illustrations include a series of photographs of the mould for a gas-engine cylinder at various stages. Moulding is considered much more fully than melting, and the book is well adapted to give a general idea of the processes used in preparing moulds, and of the organisation of a foundry. The theoretical side is weak, and some very erroneous statements as to fuel and thermochemistry would have been better omitted. The printing and illustrations are good.

C. H. DESCH.

### The Snakes of Ceylon.

*Ophidia Toprobanica, or The Snakes of Ceylon.* By Col. Frank Wall. Pp. xxii+581+1 map. (Colombo: Colombo Museum, 1921.)

A GOOD deal has been written on the subject of the snakes of Ceylon. Thus Günther's "Reptiles of British India" (1864), and Boulenger's "Fauna of British India—Reptiles and Batrachians" (1890), both include descriptions, and in the case of the former work, remarks on the habits of many of the snakes inhabiting Ceylon. There is also the "Snakes of Ceylon" by Abercromby, a small popular treatise which appeared in 1910. Except for the last-named work, which is very incomplete, there is, however, no book which deals solely with the snakes of Ceylon,

apart from those inhabiting India, and Col. Wall, an enthusiastic naturalist and specialist on Indian snakes, in producing the volume under review has succeeded in filling a long-felt want.

The author in his work gives an account of the marine snakes which may be met with around the shores, as well as the terrestrial forms. A full description is given of every snake, and the determination of the genera and species is often facilitated by useful, if somewhat unscientific, keys. Except when dealing with the sea-snakes, Col. Wall has in most cases adopted the nomenclature used in Boulenger's Catalogue of the British Museum. Sometimes the generic and specific names have been altered. It is impossible without going thoroughly into the various contested points to say whether the author is in every case justified in departing from Boulenger's classification, although he occasionally appears to have good reasons for so doing. We are not, however, always inspired with confidence in Col. Wall's judgment. Thus "until I am satisfied of their specific unity I prefer to regard them as distinct species" is the dogmatic reason he gives when advocating specific distinction for certain forms of Kraits, held by Boulenger, in spite of their distinctive coloration, to be only geographical varieties of the same species.

A feature of the book is the very full account given of the habits of the snakes. The author has had practical experience of the reptiles in their native haunts, and his descriptions of their feeding and breeding habits add greatly to the value of the work. There are also some interesting remarks on the subject of distribution. Many snakes inhabiting upland regions have a very restricted habitat, neither ascending nor descending beyond certain limits. The elevated ranges and peaks, where the lower slopes merge into the low country, are just as effectually isolated as if they were surrounded by the sea.

Much space is devoted to the subject of snake-bite, for the benefit of the medical practitioner, and a number of illustrative cases from the records of various doctors are given.

E. G. B.

### Japanese Social and Economic Life.

*The Foundations of Japan: Notes made during Journeys of 6000 Miles in the Rural Districts as a Basis for a Sounder Knowledge of the Japanese People.* By J. W. Robertson Scott. Pp. xxv+446+plates. (London: J. Murray, 1922.) 24s. net.

THIS is an eminently readable book, giving not only the familiar glimpses into superficial Japanese life, but also treating of the economic life of

the nation in a really profound manner. The author spent four and a half years travelling through the country, studying the habits and thoughts of the men and women of the countryside, who were trained under rural schoolmasters and village elders and are living their life under the potent sway of long-established tradition. The modern industrial developments of factory life are also depicted with a sure hand, and where there is much to praise there is also much to condemn. For example, the conditions under which silk-factory girls work are little short of slavery, and would be impossible in English-speaking countries. On these and other deeper aspects of Japanese life the author evidently speaks with knowledge. With real sympathy and honesty he describes the present-day sociological conditions which rule among the great majority of Japanese. As he himself says, he went to Japan to see the countrymen.

"The Japanese whom most of the world knows are townified, sometimes Americanised or Europeanised, and, as often as not, elaborately educated. They are frequently remarkable men. They stand for a great deal in modern Japan. But their untownified countrymen . . . What is their health of mind and body? By what social and moral principles are they swayed? To what extent are they adequate to the demand that is made and is likely to be made upon them?"

Such are some of the questions which Mr. Scott sets himself to answer. This he does by describing his wanderings in various provinces, touching upon all kinds of Japanese customs as they come before him. The result is in many cases a curious mosaic of random thoughts, greatly satisfying to one who has lived in Japan, but probably not a little confusing to one who has never been there and is reading for enlightenment. In other chapters, however, there is a sustained and serious discussion of some broad aspect of Japanese life. In all cases the author writes with a freshness and accuracy which bespeak a full knowledge and a discriminating judgment.

Dealing as it does with the facts at the basis of human life, the book is aptly called the "Foundations of Japan." From this point of view the book is a real addition to ethnological literature, and is worthy of commendation in the pages of NATURE. For the more serious student of industrial economy there are some interesting appendices with instructive statistics; and well-chosen drawings and photographs elucidate many of the questions discussed. Among the subjects treated at considerable length are the cultivation of rice, the whole process of sericulture, the problem of labour, and the education of boys and girls. In conclusion it may be said that Mr. Scott has the gift of a true teller of stories, many of which show forth in

a graphic way some characteristic traits of our Eastern Allies.

### Hull and the East Riding.

*Handbook to Hull and the East Riding of Yorkshire: Prepared for the Members of the British Association for the Advancement of Science on the Occasion of their Visit to Hull, in September 1922.* Edited by T. Sheppard. Pp. viii + 532. (London and Hull: A. Brown and Sons, Ltd., 1922.) 5s.

THE ideal handbook in connexion with the annual visits of the British Association has yet to be written, but it would be unfair if we withheld the full meed to the editor and sub-committee who have produced this interesting publication. It approaches nearer to our ideal than that issued at any previous meeting; so far as possible technicalities have been avoided, for the work is not intended for the expert, who already knows the special works and articles relating to the different subjects treated of. It is essentially a guide for the average member who wishes to learn something of the history, archæology, antiquities, folk-lore, geology, natural history, and economics of the town and district in which the parliament of science has recently been held.

After a brief account of the evolution and growth of Hull, we pass on to short accounts of its past history and antiquity, its rise and progress, places of interest, Hull coins and tokens, its charters, etc. The various prehistoric remains of East Yorkshire are briefly described and illustrated, and interesting chapters are devoted to the Romans, Anglo-Saxons, and Danes in this division of the county. The Rev. Canon A. N. Cooper contributes a well-illustrated chapter on East Riding churches, and Mr. John Nicholson one on East Riding place-names. There are further sections treating of the charities, engineering and shipbuilding, education, agriculture in the East Riding, while the geology and lost towns of the Humber receive very full treatment at the hands of the editor.

Nearly three hundred pages are devoted to the description of the fauna and flora, and in spite of the fact that some of the writers have not been able to depart from the useless local list method of treatment, the various contributors have handled their sections most ably. An outstanding feature is Mr. John W. Taylor's excellent account of the land and freshwater mollusca. The weakest section is undoubtedly that on the crustacea, which is unfortunate, as much good work has been done on the non-marine forms.

Apart from its value and usefulness to the visitor to Hull, this work will fulfil a double service if it serves

to show the citizens of Hull the many points of interest their city possesses, and of which they are the trustees.

The wealth of illustrations considerably adds to the interest of this work. Future compilers of the British Association local handbook will do well to study carefully the Hull model.

W. E. C.

### Our Bookshelf.

*The Biology of the Seashore.* By F. W. Flattely and C. L. Walton. Pp. xvi + 336 + 16 plates. (London: Sidgwick and Jackson, Ltd., 1922.) 16s. net.

THE study of zoology from the ecological standpoint has made rapid strides in America under the energetic leadership of Dr. Adams and Dr. Shelford, and there has been a steady output of text-books and popular books on Nature study written from this point of view. In this country, zoological ecology has received very little attention, and we welcome, therefore, if only on these grounds, this excellent work on the biology of the seashore. As the authors point out, their book is not intended to supersede but to supplement previous works which have been written on classificatory and morphological lines. In fact, they demand a previous knowledge of classification and external morphology in those who use their work. Given this the authors have directed special attention to functional biology and to the adaptations which organisms present to marine life in all its phases.

The book is an exhaustive summary of the known facts of marine biology from the ecological point of view, and reveals a wide knowledge of the literature of the subject. The illustrations are good and adequate, and the advice given on the methods of ecological research should be most useful to students. The authors, however, have not been content merely to summarise known facts. The book bristles with suggestions for research and further inquiry, and in this respect is most stimulating. It should be in the hands of all students of marine biology. With its help more real knowledge of life in the sea will be obtained than from any other text-book we know. It is not enough to know the mere population of the sea; some knowledge of the laws governing life there, and of the actions and interactions of organism and environment is vastly more interesting and stimulating, and the work under notice supplies the right kind of guidance in this inspiring field of study.

*Catalogue of the Books, Manuscripts, Maps, and Drawings in the British Museum (Natural History).* Vol. 6. Supplement: A-I. Pp. iv + 511 + 48. (London: British Museum (Natural History), 1922.) 2l. 15s.

THE Library of the British Museum of Natural History is probably one of the most complete, and certainly one of the most important, libraries of works on natural history in the world. The publication of a catalogue of its contents has been of immense service to scientific workers, who find in it a valuable guide to the literature of their subject and a wealth of bibliographical detail which is of the greatest value in settling vexed questions of priority and ensuring accuracy of reference. The first half of the supplement to the main catalogue has

now been issued and serves to give some idea of the natural growth of this splendid library. Like the preceding volumes, it has been prepared by Mr. B. B. Woodward with the same meticulous care and accuracy, and includes as before the results of much bibliographical research by the author and Mr. C. D. Sherborn. The 48 pages of "Addenda and Corrigenda" to the main catalogue consist almost entirely of additional bibliographical information which has accumulated since the catalogue was published.

The expenditure of public money on the publication of a catalogue of this kind is more than justified by its extreme value and usefulness, though it is a pity that so valuable a work as this supplement should have been sent out in a paper cover. For its own value and for the sake of uniformity it is worth a binding similar to its predecessors. Scientific workers are grateful to Mr. Woodward and to the trustees of the British Museum for having made the resources of their library known in this readily accessible form.

*Obras completas y correspondencia científica de Florentino Ameghino.* Volumen 3. La Antigüedad del Hombre en el Plata. Dirigida por Alfredo J. Torcelli. Pp. 821. (La Plata: Taller de Impresiones Oficiales, 1915.) n.p.

THE third volume of the handsome collected edition of the late Florentino Ameghino's geological and palæontological works now being issued by the government of the province of Buenos Aires, is a reprint of his treatise on the antiquity of man in La Plata originally published in 1880. Francisco Moreno had then just founded the Anthropological and Archaeological Museum at Buenos Aires (afterwards removed to La Plata), and Ameghino himself was studying with Henri Gervais in Paris, where he exhibited part of his collection at the Universal Exposition. The author was thus well furnished with materials, and had unusual opportunities of making himself acquainted with the latest advances in the subject of the antiquity of man. While describing the results of his own researches, he therefore took the opportunity of making many references to European and North American work which were illuminating. His volume is a most exhaustive discussion of the remains of the handiwork of prehistoric man discovered in Argentina, illustrated by twenty-five large plates. Of the skeleton of man himself no important fragments had at that time been found. The geological observations are particularly valuable and interesting, and Ameghino seems to make it quite clear for the first time that the man of the pampas was a contemporary of the extinct glyptodonts or giant armadillos, and actually used their large bony carapaces as roofs for his lowly habitations. Although naturally out-of-date, the whole treatise is a valuable record of facts and observations, in which the reprint will stimulate renewed interest.

A. S. W.

*Le Pôle Sud : Histoire des voyages antarctiques.* Par J. Rouch. Pp. 249. (Paris: Ernest Flammarion, 1921.) 7 francs net.

M. ROUCH was one of the officers of the *Pourquoi Pas ?* in Dr. Charcot's second Antarctic expedition, and familiarity with the conditions of navigation and the privations of wintering in the Far South has given him

a great advantage in dealing with the history of exploration in the South Polar regions. With the space at his disposal no one could have done better than M. Rouch in setting forth with equal detail all the outstanding Antarctic voyages from that of Cook in the *Resolution* to that of Shackleton in the *Endurance*. Except for a very few slips in the spelling of names (*Thun* instead of *Chun* on the *Valdivia* is the only serious one) the accuracy of the work is quite remarkable, and the facts regarding the various expeditions have obviously been selected from the original narratives.

The style is lively and sympathetic but concise and sailorly. M. Rouch holds all explorers as his brothers and there is a delightful air of *cameraderie* in his treatment of the aspirations and achievements of British, French, Russian, American, Swedish, Norwegian, and German explorers. It is refreshing to find this fine French sailor giving credit impartially to his German rivals and his French colleagues, and with an almost British self-criticism touching more frankly on the little shortcomings of his fellow-countrymen than on those of foreigners.

Perhaps the author's imagination has assisted a little in describing the details of Scott's last expedition; but if he here allows dramatic truth to prevail over verbal accuracy it is in excess of sympathy.

The numerous illustrations are excellent as showing Antarctic conditions, but they obviously refer only to the author's own section of the region. H. R. M.

*Mineral Land Surveying.* By Dr. J. Underhill. Third edition, revised. Pp. viii+237+3 plates. (New York: J. Wiley and Sons, Inc.; London: Chapman and Hall, Ltd., 1922.) 17s. 6d. net.

DR. UNDERHILL'S book describes the methods in use for the survey of the mineral lands in the western portion of the United States. It should certainly be in the possession of all surveyors who intend to proceed there; but only the first three chapters are likely to be of much service to mine surveyors in England. In chapter 1, on direct solar observation, the method of obtaining the true meridian by single observations on the sun is clearly and fully explained, with the aid of several worked examples, after the derivation of the formula employed has been given. The method of obtaining latitude by solar observation is also briefly described. Chapter 2 describes the Shattuck Solar Attachment, the Burt Solar Attachment, and the Berger and Saegmuller Solars and their use for finding true meridian and latitude. Of these, the Shattuck Solar Attachment appears to find most favour with the author, who states that he has obtained perfect checks on this instrument by direct observation of the sun. Chapter 3 is a useful account of traversing and measurements, including stadia measurements. Other chapters deal with location surveys, including calculation of areas by the double meridian distance method, patent surveys, patent field notes, Land Office and Records, and the examination for commissions as United States Mineral Surveyor with typical questions and solutions. The appendix includes extracts from the Manual of Instructions for the Survey of the Mineral Lands of the United States.

*L'Océanographie.* Par Prof. J. Thoulet. (*Science et Civilisation: Collection d'exposés synthétiques du savoir humain.*) Pp. ix+287. (Paris: Gauthier-Villars et Cie, 1922.) 9 francs.

THIS book is one of a series which offers a general account of modern scientific research in its relations to civilisation: it is written in a pleasant, continuous manner and, on the whole, is a very good exposition of the main results of physical oceanography. It follows the line of treatment which appears now to have become classical since the publication of Krümmell's big book in 1907-11: an account of the bottom of the ocean and its deposits; the physics and chemistry of sea water; waves and tides; and the formation of ice. The ocean in its relation to life and the development of the foreshore and coast-line are scarcely touched. The theory of the tides is dealt with very slightly, and the statement is made that all tidal problems have been elucidated by Airy's "théorie des ondulations": quite lately, of course, the dynamical theory of the tides has been almost transformed. There is no account of the methods of prediction.

In such a work as this figures and charts are indispensable, yet the book under review only contains eight text-figures and these are rather difficult diagrams. It can be read with advantage and by the non-professional reader only with constant reference to a good atlas of physical geography, and there is no such work in existence which includes all the recent investigations of marine currents and drifts. J. J.

*The Misuse of Mind: A Study of Bergson's Attack on Intellectualism.* By Karin Stephen. (International Library of Psychology, Philosophy, and Scientific Method.) Pp. 107. (London: Kegan Paul and Co., Ltd.; New York: Harcourt, Brace and Co., Inc., 1922.) 6s. 6d. net.

THIS important study of Bergson's philosophy is not an attempt to epitomise or expound the principle, the method, or the particular content. It concentrates on an attempt to understand what is generally rejected as unintelligible—the attack on intellectualism. In Bergson's view the tradition of philosophy is all wrong and must be broken with; philosophical knowledge can be obtained only by "a reversal of the usual work of the intellect." The author gives us in three chapters first a criticism of "explanation," then a criticism of "fact," both with reference to Bergson's theory of change, and in a final chapter shows how light is thrown on the problem by his theory of the relation of matter to memory.

*Les Sciences et le Pluralisme.* Par J.-H. Rosny, aîné. (Nouvelle Collection Scientifique.) Pp. iv+219. (Paris: Félix Alcan, 1922.) 8 francs net.

M. ROSNY'S thesis is that "pour retrouver l'uniforme nous sommes contraints de nous battre sur des substances ou des énergies hypothétiques. En fin de compte, l'homogène que nous trouvons est subi ou créé par le moi, mais non strictement donné par les choses." The volume contains a lucid discussion of the most recent theories in mathematics and physics.

### Letters to the Editor.

[The Editor does not hold himself responsible for opinions expressed by his correspondents. Neither can he undertake to return, or to correspond with the writers of, rejected manuscripts intended for this or any other part of NATURE. No notice is taken of anonymous communications.]

#### Mersenne's Numbers.

IN my presidential address to Section A of the British Association, reprinted in NATURE (September 16), I stated that 137 was the least value of  $n$  for which the prime or composite character of  $2^n - 1$  was still undecided. Mr. W. W. Rouse Ball has pointed out to me that this is incorrect, as  $2^{137} - 1$  has been shown to be composite by M. A. Gérardin (*Comptes rendus du Congrès des Sociétés Savantes*, 1920, pp. 53-55). The result is quoted in *The American Mathematical Monthly*, vol. 28, 1921, p. 380. The number 139 should therefore be substituted for 137 wherever it occurs in my address.

The authorities on which I relied were Prof. L. E. Dickson's "History of the Theory of Numbers" (vol. 1, Washington, 1919) and the seventh edition of Mr. Rouse Ball's "Mathematical Recreations" (1917, now superseded by the tenth). My quotation from Mr. Rouse Ball was taken, as I stated, from a pamphlet written thirty years ago, and is, of course, not to be interpreted as an expression of his present view.

G. H. HARDY.

New College, Oxford, October 4.

#### Animal Mechanism.

THE notion that the legs of animals behave as pendulums is ascribed to the brothers Weber. I can find no indication that the notion was more than a general one, and, in the general sense, when pointed out, it is obvious to a student of dynamics, for legs have inertia and weight and dynamics is reasonably near to the truth.

A better view may arise from the supposition that animals may be regarded as dynamical systems with many natural modes and frequencies, and that animals adapt their methods of locomotion and other actions to suit these fundamental characteristics. As examples, we have the lounging gait of very tall men and the apparently energetic step of short men. The tripping, half running step of women and children is also in point. Apart from mere legs the moment of inertia about the feet must be important, as may be seen in the stately carriage of quite short women in the East when carrying water vessels on the head. Sir George Greenhill has given several examples of this in his notes on dynamics, among them being interesting examples of the carrying of soldiers' kit.

A further point of interest arises in regarding legs a little closely, for they are not simple but multiple pendulums with more than one natural mode. When a horse or man is walking the leg appears to vibrate in the slowest mode of the pendulum and the joints are or appear to be on one side of the vertical. In the running gait, however, the thigh points forward while the lower parts point backwards. Probably the "reason" why a horse's forelegs are more flexible than the hind legs is to make him nimble in balance and steering; a horse could not stumble with his stiff hind legs.

The dynamics of locomotion is of interest to the student of engine balancing, for in the natural gaits of

man and horse there is a utilisation of balancing principles. In man the right leg moves forward while the right arm moves backward, in the horse the right legs are always moving in opposition and similarly the left legs, of course. This holds for the walk, the trot, and the gallop, all natural modes. In the amble, an artificial stride due to the trainer, the legs on either side are in phase and an ungainly motion results, though it is comfortable for the rider. This amble stride is natural to the giraffe, but the latter has a long neck to give it poise. The balancing view of animal locomotion may be realised at once by any one who will try to run with stiff arms or will try to walk with his arms tucked up in the running posture. The runner is compelled by dynamics to move his legs in a quicker mode than when walking. His arms are so jointed that he cannot alter their type of vibration, and he is therefore compelled to reduce their inertia in order that they may oscillate in time with his legs. The balance from the engineer's point of view is imperfect, and thus stresses are imposed in the trunk. Hence sprinters are well-bodied men and horses need girth for speed. As a final example of these facts, let any one try to run to the station with a heavy suit-case in his hand. Porters usually carry such things on their shoulders and stride rather slowly.

There is a further point of interest in connexion with the viscera. If dynamics is true, the various internal organs have inertia and their attachments have elasticity; thus they must possess natural frequencies. This being so, they must be subject more or less to the phenomena of resonance. Is seasickness, subjective agencies apart, to be explained in this way? Some people before embarking have a copious meal, others pin their faith and hope to a single bottle of stout, while yet others proceed fasting. Is this a phase of dynamical tuning? In 1914 I read a short paper on the dynamics of the human foot at the British Medical Association's summer meeting. The outcome of the discussion was that tonicity was more potent than mechanics, or, in other words, living tissue may vary in its properties on account of tone or debility to a degree which will exceed the influence of configuration. The contention would be that while astringents or food may alter the effects of a sea voyage, the action is due to dynamical effects; the inertia of the stomach or the stiffness of its suspension is varied—opiates and such like are here excluded.

A medical writer of some eminence recently advocated walking because "Nature has ordained that the finest exercise of all is that which she bestows." While this is reminiscent of Heine's "Harzreise," the greenness of grass and the length of a donkey's ears, there is in it matter for reflection. Motor car designers, led by Dr. Lanchester, have found that the most comfortable predominant natural frequency of a motor car is between 80 and 100 per minute; it is a curious coincidence that this is also the frequency of the ordinary walking step. Has the human system, enforced by dynamics to walk in a certain rhythm, acquired an internal system and a nervous organisation to meet this rhythm? It is worthy of note that in certain cars several dogs and children have been actually and violently sick and in other cars sprung to vibrate with a different natural period they are immune. Shall we, disagreeing with Shylock, say, "It is not their humour, but their natural frequency"?

H. S. ROWELL,

Director of Research,  
Research Association of British Motor  
and Allied Manufacturers.

15 Bolton Road, W., September 20.

### Vegetable Rennet.

I HAVE been endeavouring to make a list of plants—leaves, flowers, seeds, etc.—used in various countries for coagulating milk in place of rennet, obtained from the stomachs of young animals; and I shall be glad to learn of any additions that might be made to the following list:—*Galium verum*, *Withania coagulans*, *Ficus Carica*, *Cynara cardunculus*, *Cynara scolymus*, *Carduus nutans*, *Cnicus benedictus*, *Drosera peltata*, *Datura Stramonium*, *Pisum sativum*, *Lupinus hirsutus*, *Ricinus hirsutus*, *Pinguicula vulgaris*, *Leucas cephalotes*, *Crotalaria Burkia*, *Rhazya stricta* and *Strebilus asper*.

With regard to some of the plants named above, I would note that the references are not very clear as to their use for milk coagulation. Any information as to plants used in former days or at the present time would be welcome and useful. A Hindu, also an orthodox Jew, cannot touch, I understand, a milk product that has been coagulated by rennet obtained from a calf's stomach, and must therefore use a vegetable coagulant; and I believe that there are other races in other parts of the world which use vegetable coagulants. So far as I am aware, an approximately complete list of plants used in various parts of the world for coagulating milk does not exist, and where a reference is found, details given are scanty as to part of plant used, its preparation, and method of use.

R. HEDGER WALLACE.

4 East Grove, Cardiff, September 20.

### A Question of Nomenclature.

In his notice of Mr. S. Q. Hayes's "Switching Equipment for Power Control" in *NATURE* of September 16, p. 374, your reviewer, commenting on current Americanese, says: "Electrical engineers talked about 'omnibus bars' thirty years ago, it then became 'bus bars,' and now apparently it has become 'busses.'" Webster, who may be considered as an authority on the language of that great nation, defines a buss as "a kiss; a rude or playful kiss; a smack," and quotes Herrick to the effect that:

Kissing and bussing differ both in this,  
We buss our wantons, but our wives we kiss.

So that although in both "bus bars" and "busses" there is intimate contact and at times electricity passes, it can scarcely be said that the two terms are synonymous. Nor can it be said that the introduction of such terms into electrical engineering is to be commended.

F. H. MASTERS.

### Capillarity.

In a letter on capillarity in *NATURE* for September 16, p. 377, Mr. Wilson Taylor shows how difficult it is to account on physical grounds for the phenomena exhibited by liquid films.

It may not be out of place in the circumstances to refer to Irving Langmuir's views on this subject, given by him in a paper on "The Constitution and Fundamental Properties of Solids and Liquids. II. Liquids" (*Am. Chem. Soc.*, vol. xxxix., September 1917, p. 1852). Langmuir cites a few of the cases in which the forces between the molecules have been considered to be radial forces which vary solely as a function of the distance between molecules. In all these cases the investigator has considered the phenomena to be physical in nature. He then goes on to remark: "The chemist, on the other hand, in studying the properties of matter, usually employs totally different methods. He is often most interested in the qualita-

tive aspects of the problem, and the quantitative relationships are usually limited to those deducible from the law of multiple combining proportions, the law of mass action, or the principles of thermodynamics. When the chemist does consider the forces acting between atoms and molecules, he does not look upon these as forces of attraction between the centres of the molecules, but he thinks rather of the specific nature of the atoms forming the molecules and the manner in which these atoms are already combined with each other. He thinks of molecules as complex structures, the different portions of which can act entirely differently towards any given reagent. Furthermore, he considers that the forces involved in chemical changes have a range of action which is usually much less than the diameter of a molecule, and perhaps even less than that of an atom."

What has been termed the Classical Theory of surface forces has proved useful in its day; but it unfortunately ignores *chemical affinity*.

R. M. DEELEY.

Tintagil, Kew Gardens Road, Kew, Surrey,  
September 15.

### Lead and Animal Life.

DR. GARRETT'S communication in *NATURE* of September 16, p. 380, on the effect of a lead salt on Lepidopterous larvæ, is particularly interesting to one who has been working on an allied subject. Recent investigations of my own on the fauna of lead-polluted streams in North Cardiganshire, as reported at the Hull meeting of the British Association, point to the presence of dissolved lead-salts in these rivers as distinctly inimical to the aquatic population, in particular to the larvæ of certain insect-groups, such as Trichoptera, which are normally non-existent in these streams, though well represented in their neighbourhoods.

The case of fattening of Weardale sheep on lead-polluted pastures may perhaps provide a parallel; while it is quite possible that small doses of lead may have a tonic effect, cases of lead-poisoning proper among farm live-stock in general are common in certain districts (see a paper on "Plumbism in N. Cards." by E. Morgan, *Journal of U.C.W. Agricultural Dept.*, 1915), and usually the poisoning is of the type known as "chronic," the effect being slow and cumulative, as is also established in the case of lead-poisoning as an industrial disease. It would be interesting to know whether Dr. Garrett's experiments have extended over more than one generation of Lepidoptera, and whether the reproductive faculties were in any way affected.

K. CARPENTER.

Department of Zoology, University College  
of Wales, Aberystwyth.

### Polar and Non-Polar Valency in Organic Compounds.

THERE is an increasing tendency on the part of organic chemists to apply the Berzelius dualistic theory, in a modified form, to organic compounds. In many theories of valency, individual groups are considered to be more or less electropositive or electronegative, and it is possible to arrange these groups, approximately, in a table of descending electropositive character. A difficulty which arises in examining this conception is to visualise the transference of anything less than one electron between the group and the remainder of the molecule. There appear to be at least two kinds of forces operating between atoms in a molecule, which can

be designated as polar and non-polar. The polar character of the valency in the majority of salts is definite; there is experimental evidence for the transference of electrons in these substances. The non-polar forces are particularly in evidence in the linkings of organic compounds, and it is extremely unlikely that transference takes place to an appreciable extent here. Without entering into a discussion of the nature of the non-polar forces, which may be electromagnetism, there are two explanations which may be given of the undoubted positive and negative relationships of groups in organic compounds. In the first place, there may be a partial transference of an electron between the group and the residue of the molecule, or alternately there may be a varying concentration of polar molecules in the typically non-polar substance.

I venture to put forward a plea for the consideration of this second possibility. An equilibrium may be imagined to exist between the polar and non-polar substances which will be affected by the temperature, solvent in which it is dissolved, etc. Thus, in an organic substance AX the equation,



may represent this kind of equilibrium, and the more electronegative the group X the more will this reaction proceed to the right. In those substances where the stability of the non-polar arrangement is very great, the occurrence of both forms,  $\overset{+}{A}X$  and  $\overset{-}{A}X$ , will be possible, and in the presence of a suitable solvent these may give rise to the respective ions. This view is in agreement with the occurrence of a group in some compounds with an electropositive, and in others with an electronegative tendency. The ease of replacement of the group X by another group will be determined by the concentrations of the polar body, the polar state being the active form of the substance. These concentrations may be so small as to escape the ordinary methods of measurement, and yet be sufficiently great to explain the velocity of the chemical action.

W. E. GARNER.

University College, Gower Street, W.C.1,  
October 4.

### The X-ray Structure of Potassium Cyanide.

WRITING in a contemporary (J.A.C.S., Feb. 1922), Richard M. Bozorth gives details of X-ray investigations into the crystalline structure of KCN, and corroborates the view expressed in a letter to this journal (NATURE, Aug. 11, 1921, vol. 107, p. 745) that the underlying structure is the face-centred cube. He gives 6.55 Å as the length of its edge, which agrees very well with the 6.54 Å furnished by my measurements. He goes further in that he assigns definite positions to the carbon and nitrogen atoms and questions the opinion, expressed by Langmuir, that these constituent atoms of the CN radicle have a common outer electron shell.

Bozorth's conclusions are, to a certain extent, based on the assumption that the relative intensities of the spectra would fall off in a normal manner if the structure were quite like that of NaCl, that is, if the carbon and nitrogen atoms formed a single cluster of electrons which occupied the same position in the KCN structure as the chlorine atom does in NaCl. He publishes no numbers representing the observed intensities, but gives 100 : 10 : 3 as the relative values of the [100], [200], and [300] reflections that would be required to satisfy the requirements of his particular structure. My own measurements gave 16.17

as the relative value to be assigned to the [200] reflection, and the corresponding figure for NaCl is 20. Now the fact that KCN has a lower fusing-point than NaCl suggests that even at ordinary temperatures the heat vibrations are of unusual amplitude, and this in itself affords a ready explanation of the fact that the intensities of the spectra die away more rapidly than is normally the case. The probable electron distribution in a composite CN radicle is another important factor which would cause the normal sequence to fall off rapidly.

Bozorth gives 1.15 Å as the distance between the centres of the carbon and nitrogen atoms, and 3.0 Å as the distance between either of these and the potassium atom. He treats the carbon and nitrogen atoms as though they were of the same size, but he does not state whether or not the inter-nuclei distance is to be taken also as the effective diameter. In one case his figures would give 4.85 Å as the diameter of the potassium atom compared with 4.15 Å, which represents, probably to within 0.03 Å, its value in the other ionised salts in which it occurs (W. L. Bragg, *Phil. Mag.*, Aug. 1920). If, on the other hand, 4.15 Å be accepted as its diameter in KCN—and measurements on NaCN justify this procedure—then Bozorth's figures would give 1.85 Å as the effective diameters of both carbon and nitrogen; W. L. Bragg's values are 1.54 Å and 1.30 Å respectively.

Fortunately, there is outside evidence which bears directly on this question. From viscosity measurements A. O. Rankine has found (*Proc. Roy. Soc.*, July 1921) that the  $C_2N_2$  molecule behaves in collision like two overlapping hard spheres, each having the size of a bromine atom. The diameter of the bromine atom is 2.38 Å, and that of a Langmuir CN radicle, as provided by X-ray measurements, is 2.39 Å.

P. A. COOPER.

Research Dept., Royal Arsenal, Woolwich,  
September 20.

### Sex Change in Mollusca.

WITH reference to Dr. R. Spärck's statement (NATURE, October 7, p. 480) that the male stage in the oyster is due to the coldness of the temperature, it should be pointed out that in various hermaphrodite mollusca, such as *Helix* and *Arion*, the reason for the passage of the indifferent epithelial cell, either to oogonium or spermatogonium, is at present unknown. Older authors considered that those cells near yolk, or near a superior nutritive radius became eggs, and that those less exposed to steady streams of nourishment became spermatocytes.

More recent work has shown that the matter is very deep-seated, and such a conclusion as the above cannot be taken as representing the real state of affairs. I have found that oocytes appear in regions of the ovotestis which are scantily provided with yolk, and that sperm cells appear in regions rich in nutriment.

Whether temperature has anything to do with this has not yet been ascertained, but experiments are now in progress, which should settle the question.

In the case of *Saccocirrus* it has been shown that spermatocytes caught up and enclosed in yolk cells have their metabolism so altered that they assume the appearance of oocytes, together with nucleolar extrusions characteristic of the typical oocyte.

But in *Helix* two epithelial cells side by side often metamorphose, one into an oogonium, another into a spermatogonium, and one seems obliged to believe that factors other than temperature or abundance of nutriment are concerned. J. BRONTE GATENBY.

Trinity College, Dublin University,  
October 7.



The Galactic System.<sup>1</sup>

By Dr. HARLOW SHAPLEY.

## I.

THROUGHOUT the known sidereal universe there is, among material bodies, an obvious associative tendency, which we see well illustrated in meteor showers, in satellite and planetary systems, in binary stars, and in larger stellar groups such as the Pleiades. These various products of gravitational ordering are clearly but parts of still greater systems, and one of the most fascinating of astronomical studies is to attempt to seek out the structure of an all-inclusive sidereal organisation.

It is proposed in this communication to discuss the structure and extent of the sidereal system as indicated by recent studies of stellar clusters and variable stars. My own observational investigations of these objects, and the deductions based upon them, have been mainly published in Contributions and Communications of the Mount Wilson Observatory<sup>1</sup> from 1914 to 1918. The present discussion is made in the light of criticisms and numerous tests to which the conclusions have been subjected during the past four or five years.

It appears that we have three principal types of celestial objects to consider—the diffuse nebulae, the stars, and the nebulae of the spiral family. The first two are generally thought to be related as parent and offspring. The stars, having formed, as we think, out of nebulous pre-stellar states, are, apparently, largely organised into groups, a common, possibly prevailing form being the globular cluster. It is from combinations of these clusters that I believe our galactic system has developed.<sup>2</sup> From the work on clusters there can be little doubt of the enormous mass and dimensions of the galactic system as compared with clusters and nebulae. Its flat form and heterogeneity, its content of numerous fragmentary systems (open clusters, wide binaries, spectrally-similar groups) of apparently different ages and separate origins, and its control over the motions of the clusters and near-by spirals, have led me for some years to advocate the hypothesis that the Galaxy is a growing composite of disintegrating minor systems. The Galaxy appears to include all the common sidereal types, with the probable exception of most nebulae of the spiral family. But the latter are apparently not stellar in composition, nor galactic in size. I think present evidence favours but does not establish the hypothesis that typical spiral nebulae represent a sidereal evolution not directly connected with that of stars.

The foregoing paragraph may serve as a brief outline. Some of the details may now be considered, but, before proceeding with the discussion, I should like to point out that the proposed interpretations involve the following somewhat fundamental assumptions, if we choose to call them assumptions: (1) that gravitation directs the organisation and motions of celestial bodies; (2) that the physical laws we know are equally valid in all parts of the space with which we are familiar; (3) that the Russell-Eddington theory of stellar evolution is correct in its general features.

Certainly these three are not serious restrictions. On the first I need make no comment here. The second is the basis of our belief in the general uniformity of conditions throughout the stellar system. It insists that our stellar neighbourhood is not operated by local laws. It is a highly reasonable but necessary assumption before we can safely compare the luminosities and other properties of stars near the sun with those of stars in distant parts of the galactic system. The third assumption, the Russell-Eddington theory, is not necessary for my conclusions concerning the dimensions of the galactic system, but is essential in putting together the general scheme, and also in trying to interpret some anomalies of the spiral nebulae. We might call the evolutionary scheme the Lane-Lockyer - Ritter - Sampson - Emden - Schwarzschild - Hertzsprung - Russell - Eddington - Jeans - Eggert theory, but Russell and Eddington have been the most important contributors to the theory in its present form.

## CONCERNING STAR CLUSTERS.

Clusters of stars can be placed in two fairly distinct categories, the globular cluster, of which nearly ninety are now known, and the open or loose cluster, of which there are several hundred.

Most globular clusters (but not quite all) appear to be remarkably alike in general structure. Compared with naked-eye objects they are extremely remote; hence their stars, though apparently very faint, are actually of high intrinsic luminosity. Few stars in globular clusters are brighter than the eleventh apparent magnitude. Each globular cluster contains some tens of thousands of these intrinsically bright stars, and possibly a far greater number of dwarfs, which at present are beyond the reach of our telescopes. Of high importance is the fact that the cluster stars appear to be remarkably similar to the stars in the solar neighbourhood in spectral type, colour, variability, and other properties, notwithstanding the much higher stellar density near the centres of globular clusters.

Open clusters are of great variety. They range in brightness from naked-eye systems, such as the Hyades, to small, dim groupings that may be nothing more than chance aggregations of faint Milky Way stars. Open clusters vary also in richness, in apparent and real dimensions, in stellar content. One property they have in common: they are all near the plane of the Milky Way. The distance of the average open cluster is smaller than that of globular clusters, but the determination of distances for the former is generally subject to much uncertainty. This fact is due to variety of form and content, and to the absence from open clusters of peculiar types of highly luminous stars, which for globular clusters serve to determine positions in space.

The estimation of the distances of globular clusters, which has been the most important part of the work on the scale of the sidereal universe, must be based on the newer methods of measuring space. The various trigonometrical methods, when applied to globular clusters, so far give negative results, indicating only that the distances are very great. The various photo-

<sup>1</sup> Adapted from an Address given before the British Astronomical Association on May 31.

metric methods that had to be developed for this problem involve a considerable amount of photometric, spectroscopic, and statistical detail when put on a quantitative basis, and cannot be fully described in this article.

The qualitative application of the photometric methods, however, is simple. For example, we need only assume that the brightest stars in a globular cluster have the same actual luminosity as the brightest stars in the solar neighbourhood, and we can readily compute the distance necessary to give them the apparent brightness that is measured.

If we admit the similarity of globular clusters, it is obvious that either the apparent magnitude or the apparent diameter can give us the distances of them all when once we have determined the distances of those nearer the earth. In practice the distances of the nearest clusters have been determined from studies of their variable stars, of their blue stars (spectral type B), and of their red giant stars; and checked by spectroscopically-determined absolute magnitudes and by means of the relative diameters. All the methods agree in giving distances of the same order of magnitude. We thus find that the globular clusters range in distance from seven thousand parsecs to values nearly ten times as great. Their diameters are of the order of a hundred parsecs. Their brightest stars are a thousand times as bright as the sun.

#### THE STRUCTURE OF THE GALAXY.

The result of most interest that comes out of this photometric investigation is the enormous dimensions of the super-system of globular clusters and of the Galaxy. Once the positions in space are determined, it becomes clear, as had already been suspected from an inspection of the apparent distribution of clusters in the sky, that globular clusters are a part of the Milky Way system. They are associated physically with the system of stars, nebulae, and open clusters which is more or less symmetrically arranged with respect to the equatorial plane of the Galaxy. In measuring the distances of the remotest globular clusters, therefore, we are but measuring the depth of our own galactic system. That the Milky Way itself extends to distances as great as those indicated by the clusters is shown by the presence within it of highly luminous types of stars with apparent magnitude 15 and fainter.

It has been known for many years that globular clusters are not uniformly distributed in galactic longitude. They are most numerous along the edges of the southern Milky Way. That one-sided distribution is now recognised as an indication of the sun's very eccentric position in the galactic system. In this same southern part of the sky we find the densest galactic star-clouds and the greatest frequency of faint novæ and of other types of distant objects, which is but further evidence of the greater depth of the galactic system in the direction of Sagittarius. Also in that general direction are some obstructing dark nebulae, which may be wholly responsible for a peculiar phenomenon in the distribution of distant globular clusters, that is, in their seeming absence from regions very close to the galactic plane. If the obstructing material were removed, we might see, near the galactic plane, clouds of faint Milky Way stars

still more dazzling than those observed, and globular clusters still more distant than those now known, and hence find that the greatest diameter of the galactic system is even larger than the value now assigned—approximately 100,000 parsecs.

The observable dynamical relations within and without the Milky Way are suggestive of its origin. No open clusters have yet been found outside the Milky Way region, but hundreds are known within. North and south of the galactic plane the globular clusters are equal in number, and their distances from the plane are much smaller than the greatest diameter of the system. Their velocities, so far as now known, are high. Many are approaching the galactic plane with speeds that soon must bring them to it. Their present positions and motions make orbital motion around the Milky Way improbable. From the present evidence as to mass, velocity, and distribution, there can be little doubt but that the known globular clusters pass to and fro through the star fields of the galactic system, notwithstanding their observed avoidance, apparent or temporary, at the present time. Every passage must reduce the velocity and alter the form. The hypothesis that these globular clusters are being diverted by degrees into galactic regions, and gradually robbed of their stars, is upheld by observation and is not opposed by present dynamical theory. Although we see few intermediates between the globular and the more typical open clusters, many of the characteristics of the open groups strongly support the suggestion that they are the remnants of globular clusters or of other systems that have been assimilated by the incomparably more massive galactic assemblage. Nearly a dozen "moving" clusters, comprising thousands of members, are recognised among the stars within seven hundred light-years of the sun.

Two important theoretical researches by Jeans are of much significance in this view of galactic structure: (i.) the form resulting from the interpenetration of two clusters,<sup>3</sup> and (ii.) the necessity, in accounting for the present orbits of long-period binaries, of assuming their former existence in a much more compact stellar field than now exists in the solar neighbourhood.<sup>4</sup> The high stellar frequency near the centre of a globular cluster would certainly supply conditions favourable for modifying orbits, and it also might aid in explaining the origin of long-period binaries which is not otherwise accounted for satisfactorily.

The determination, with the aid of clusters, of dimensions for the galactic system much larger than had been clearly indicated by studies of the nearer galactic stars, led to a further examination of the stellar distribution in the solar neighbourhood. The hypothesis that the galactic system, as we now know it, has developed from the combination of minor groups, suggests that the brighter stars near the sun may to a large extent be members of a local system that is imbedded in and moving through the general star fields of the Milky Way. This condition actually appears to be the case, and hence the results on galactic dimensions, from clusters and from the nearer stars, do not contradict. Stars of spectral type B down to the sixth apparent magnitude seem to be almost exclusively members of a local cluster or cloud. Brighter stars of Class A are also affiliated with the same system.<sup>5</sup> Probably all

the other types are to some extent involved,<sup>6</sup> but for them the disentanglement of local system and galactic field is more difficult.

Quite analogous to the phenomenon of the Milky Way, the projection on the sky of the faint stars along the central plane of this local cloud gives rise to a sort of secondary Galaxy,<sup>7</sup> the brighter stars of which coincide roughly with the Herschel-Gould belt. The distribution of the B stars indicates that the dimensions of the local system are large compared with those of a globular cluster; the local system is also more oblate. I believe it can be better compared in dimensions, and possibly in form, with the Magellanic Clouds or with the distinctly delimited small star clouds of the Milky

Way. The various phenomena of star streaming are undoubtedly connected with the motions of and within the local system. Probably a number of our brighter "moving" clusters should be considered sub-systems in the local cloud, rather than independent systems which for the time being are near at hand.

(To be continued.)

#### REFERENCES.

1. Cf. *Astroph. Jour.*, Proc. Nat. Acad. Sci., Pub. Ast. Soc. Pac., 1915-1921, and *Scientia*, 1919-1920.
2. *Pub. Ast. Soc. Pac.*, February 1918; *M. H. Contr.*, 157.
3. *Mon. Not. R.A.S.*, 76, p. 563.
4. *Scientia*, January 1922.
5. *Harc. Circ.*, 229.
6. Van de Linde, *Thesis*, Rotterdam, 1921.
7. *Scientia*, March 1920.

## Transport of Organic Substances in Plants.<sup>1</sup>

By Prof. H. H. DIXON, Sc.D., F.R.S.

AMONG physiologists the usually accepted view is that organic substances are distributed throughout the plant by means of the bast. The wood also acts as a channel of distribution for these substances to opening buds and developing leaves, especially in spring when root-pressure is active. The sap of bleeding contains appreciable quantities of these substances, and their distribution to the developing buds in spring by means of the wood was recognised by Hartig and Sachs.

This upward transport of carbohydrates in the tracheæ seems to be accompanied with smaller amounts of proteins. Thus Schroeder showed that the quantity of proteins in the bleeding sap rises and falls with the quantity of sugar.

This view that the rising current in the tracheæ carries organic substances in it and distributes them to the growing regions has lately been impugned. It was pointed out that in many cases, ringing close below the terminal bud prevents the development of that bud because the wood is unable to transmit sufficient supplies of organic substance. As Strasburger has already shown, this interpretation rests upon the fallacy of supposing that the removal of the bark as far as the cambium leaves the wood uninjured. As a matter of fact, microscopic examination of the wood, from which the outer tissues have been stripped, shows that its tracheæ soon become blocked with air-bubbles and with substances probably exuded into them and their walls during morbid changes in the cells of the cambium, in the cells of the medullary rays, and in those of the wood-parenchyma. The blocking is accompanied with discoloration, and is most apparent in the outer layers of the wood. It is only reasonable to suppose that the efficiency of the tracheæ as channels of transmission is seriously impaired even before there is visible evidence of plugging.

It is evident that this clogging may act differentially on the water and the substances carried in it. In the first place, the whole cross-section of the wood is available for the transport of water, while probably the outer layers are mainly utilised by the organic substances. Further, colloidal deposits in the walls, and especially in the pit-membranes, would obstruct the passage

of organic substances much more than they would the water which carries them. These considerations readily explain how it is that, while the water-supply to the buds of ringed branches is adequate, the supply of organic substance may be deficient.

Apart, then, from the very slow movement of organic substances from cell to cell, there is very cogent evidence that their upward motion is effected in the tracheæ of the wood. There is no reason to believe that during this transport the walls or pit-membranes of these tracheæ oppose the passage of the dissolved carbohydrates or of the simpler proteins any more than the water which conveys them. Hence the velocity of transport of these organic substances is that of the transpiration current, and the amount conveyed in a given time depends on the velocity and concentration of the stream.

The transport of organic substances in an upward direction in plants is secondary, for, as is well known, carbohydrates certainly, and proteins most probably, are manufactured only in the upper green parts of plants—principally in the leaves, and must be transported in the first instance back from these to the stems to be distributed to the growing regions and to the storage organs.

This view that the channel for the backward and downward movement of organic substances is afforded by the bast received great support from Czapek's work published in 1897. By section of the conducting tracts in one half of the petiole he showed that depletion of the corresponding half of the blade was delayed. He also showed that only where vertical bridges connected the upper and lower portions of bark in ringed stems were the effects of ringing nullified. Oblique and zigzag bridges are ineffective. Thus transverse conveyance in the stem is negligible. The parallel and longitudinal arrangement of the elongated elements in the bast seemed to him to provide adequately for the observed longitudinal passage. Their narrowness and large colloid content did not present themselves as difficulties. Czapek also recorded the observation that the blades of leaves, the petioles of which had been killed by jacketing them with steam, did not become emptied of starch. Similarly, when the petioles were killed with chloroform-vapour, depletion was arrested. Again, anaesthetisation of the petiole, by surrounding

<sup>1</sup> From the presidential address delivered to Section K (Botany) of the British Association at Hull on Sept. 7.

it with a watery solution of chloroform, greatly delayed the disappearance of starch.

Czapek formed no definite theory as to how organic substances were moved in the bast. He was sure that the transport depends on living protoplasm. He did not consider that the streaming of protoplasm contributed materially to the motion, seeing that streaming does not occur in mature sieve-tubes. He regarded the sieve-tubes as the most important elements in the transmission of these substances, because the deposition of callus in the sieve-plates synchronises with the stoppage of transport. The transport, according to him, is not simply due to diffusion. He supposed the protoplasm to take up the organic substances and pass them on. If diffusion does not account for the passage from one particle of protoplasm to the next, it would seem that we must suppose the organic substance to be projected from one to the other.

These observations and their interpretation by Czapek have strengthened the opinion that the bast is the channel for the downward transport of organic substances. It is remarkable how little weight has been attached to the damaging criticism of Czapek's views by Deleano, especially as those views are so unsatisfactory from a physical point of view.

The latter author showed that it is inadmissible to compare externally similar leaves, which often behave, so far as depletion is concerned, very dissimilarly. He also pointed out that without any export a leaf may be depleted of all its starch within thirty-five hours, and partially anticipated an extremely interesting recent observation of Molisch—namely, that transpiring leaves lose their carbohydrates much more rapidly than those the transpiration from which is checked by being surrounded with a saturated atmosphere. Neglect of these facts led Czapek into error. Deleano also showed that organic substances continue to leave the blades even after the petioles have been killed by heat or by chloroform-vapour. The rate of depletion is reduced by the former agent to about one-third, and by the latter to one-half. If this observation is substantiated it would show that the intervention of living elements is not essential for the transport. He further found that the blades attached to petioles which were surrounded by chloroform-water lost their starch more quickly than those immersed in water.

The contradictory conclusions of Czapek and Deleano urgently call for a reinvestigation of the points at issue. If Czapek's work holds good, we shall have to regard the bast, and especially the sieve-tubes, as the channels for the transport of organic substances back from the leaf-blades where they are manufactured, and we must look for some hitherto undreamed-of method of transmission through these most unlikely-looking conduits. On the other hand, if Deleano's conclusions are borne out, we should admit that protoplasm is not necessary for the transport, and we would turn to a dead tissue as furnishing this channel.

So far as I am aware none of the earlier investigators made any estimate either of the actual quantities of organic material which are transported or of the velocities of flow in the channels which are necessary to effect this transport.

We may approach this problem from two opposite directions—(1) by dealing with the amount of organic

substance accumulated in a given time in a storage organ, or (2) by using the amount exported from an assimilating organ. The cross-section of the supposed channels of transport and the volume of the solution containing the substances in each case will give us the other necessary data.

For the first method a potato-tuber will furnish an example. One weighing 210 g. was found attached to the base of a plant by a slender branch about 0.16 cm. in diameter. In this branch the bast had a total cross-section of 0.0042 cm.<sup>2</sup>. This figure is a maximum; no allowance was made for the cross-section of the cell-walls, or for any non-functional elements in the bast. The cell-walls would occupy probably one-fifth of the cross-section of the bast. Now if the bast exclusively furnished the channel of downward transport, all the organic substance in the potato must have passed this cross-section during the time occupied in the growth of the potato. One hundred days would be a liberal allowance. According to analyses more than 24 per cent. by weight of the potato is combustible. Therefore we must assume that during this time more than 50 g. of carbohydrate has passed down a conduit having a cross-section of no more than 0.0042 cm.<sup>2</sup>. The average concentration of the solution carrying this substance could scarcely have been as much as 10 per cent. (2.5-5 per cent. would be more probable; the concentration of sugar in bleeding sap is much below this figure, and seems never to reach 4 per cent.). Assuming, however, this concentration, the volume of liquid conveying 50 g. must have been 500 cm.<sup>3</sup>, and this quantity must have passed in 100 days. Therefore the average velocity of flow through this conduit, having a cross-section of 0.0042 cm.<sup>2</sup>, must have been

$$\frac{500}{100} = 5 \text{ cm. per hour.}$$

By the second method we arrive at a different figure. Various investigators, from Sachs onwards, have measured the rate of photo-synthesis per square metre of leaf per hour. Under the most favourable conditions the amount may approach 2 g., and it has been estimated as low as 0.5 g. Taking Brown and Morris's determination for *Tropaeolum majus*, namely, 1 g. per square metre per hour, and assuming one-third of the carbohydrate formed is used in respiration in the leaf, we find that a leaf of 46 cm.<sup>2</sup> may form during ten hours sunshine 0.46 g.; during the twenty-four hours one-third of this will be respired, leaving 0.31 g. to be transported from the leaf. The volume of the solution (again assuming a concentration of 10 per cent.) will be 3.10 cm.<sup>3</sup>. The cross-section of the bast of the bundles in the petiole was 0.0009 cm.<sup>2</sup>; therefore the velocity of flow, if the bast was used as the channel of transport, must have been

$$\frac{3.10}{0.0009 \times 24} = 140 \text{ cm. per hour.}$$

Similar figures to these were derived using measurements obtained from a number of potato-tubers and from various leaves. The velocities indicated, even assuming a concentration of 10 per cent., lay in all cases between 20 cm. and 140 cm. per hour. These figures are in agreement with those arrived at by Luise Birch-Hirschfeld, as to the weight of organic material transported from leaves.

A flow of this rate through the bast seems quite

impossible. The narrow transverse section of its elements, the frequent occurrence of transverse walls, and the lining of protoplasm and large protein contents practically preclude the mass movement of liquid through this tissue. If we imagine the flow restricted to the sieve-tubes the velocity must be correspondingly increased, and the excessively fine sieve-pores, more or less completely occupied by colloidal proteins, must be reckoned with. Simple diffusion, as Czapek recognised, cannot account for the transport, and there is no reason to suppose that adsorption on the surfaces of the colloid contents of the sieve-tubes can increase the velocity of diffusion, as Manghan suggests.

As soon as one realises the volume of the solution which has to be transported, and the velocity of the flow that this necessitates, one naturally turns to consider if the open capillary tubes of the wood may not be utilised as channels of transport: Deleano's results, indicating that the depletion of leaves continues even after the living elements of their petioles have been killed, support this conjecture.

The emphasis which has been laid on the function of the wood as providing a channel for the upward movement of water usually obscures its function as a downward and backward channel also. Early experimenters, however, fully recognised that, under certain conditions, the current in the wood may be reversed. There is, of course, recent work also showing this reversed current.

By means of an eosin solution this reversal of the transpiration current may be very easily demonstrated. If the tip of a leaf of a growing potato-plant is cut under eosin solution, the coloured solution is very quickly drawn back into the tracheæ of the conducting tracts of the leaf; from there it passes into those of the petiole, and makes its way not only into the upper branches and leaves, but also passing down the supporting stem may completely inject the tracheæ of the tuber, and from thence pass up into the wood of the remaining haulms of the plant. Its passage is entirely in the tracheæ of the wood of the conducting tracts.

Another very striking experiment may be carried out with the imparipinnate leaf of *Sambucus nigra*. Its petiole is split longitudinally for a few centimetres and half removed. The remaining half is set in a solution of eosin. The solution is rapidly drawn up the wood-capillaries of the intact half-petiole, and soon appears in the veins of the pinnæ on the same side of the leaf, beginning with the lowest, and gradually working up into the upper ones. Finally it appears in the terminal pinna. All this while the veins of the pinnæ on the other side remain uncoloured. Now, however, the eosin begins to debouch into the base of the uppermost of these pinnæ and spreads through its veins; finally it makes its way down the offside of the rachis to the bases of the lower pinnæ, and from thence spreads into their veins. In this case we see very clearly how transpiration actuates an upward current on one side and a downward current on the other. It is interesting to note that if the terminal pinna and its stalk is removed the eosin does not appear in the pinnæ of the second side, or only after a considerable time, when the small anastomosing conducting tracts are utilised.

Luise Birch-Hirschfeld also described recently many

experiments with herbaceous and woody plants, tracing the path of the reversed current by means of lithium nitrate and eosin.

In all these cases the tension of the sap determines the flow from a source wherever situated, and transpiration from the leaves, or parts of leaves, which are not supplied with liquid water from without, draws the water through the plant along the channels of least resistance. Hence it is that if the cut vein of a lateral pinna provides the point of entry, the solution may pass backwards in some of the conducting tracheæ, leaving others quite uncoloured, so that some of the veins only of the pinna are injected. The injected tracts bring the solution down the rachis and petiole into the stem, while a few or many, as the case may be, remain filled with colourless liquid, presumably the sap drawn upward to supply the transpiring surfaces of the leaf. Generally the coloured liquid descends an appreciable distance in the tracheæ of the stem before it begins to rise in the ascending current, mounting to other transpiring leaves. As a rule after some time—depending on the rate of transpiration and the amount of water supplied by the roots—the presence of the coloured liquid may be demonstrated in certain continuous series, or filaments of tracheæ in several bundles of the lower parts of the stems. Similarly, if tubers or rhizomes are present, examination of these parts, after a suitable interval, will show that many of their filaments of tracheæ are injected. Meanwhile the parts above the supplying leaf become coloured, and it will be seen that the distribution of coloured tracheæ is decided by the anatomical connexions of those filaments of tracheæ which convey the coloured liquid directly from the point of supply through the petiole to the stem. In tracing the path of the solution one is impressed with the fact that the path of least resistance is by no means always the shortest path in the wood. Transverse motion across several tracheæ seldom occurs, and the separate linear series of conducting tracheæ are practically isolated from each other laterally. Here we may recall Strasburger's experiments showing the very great resistance offered to the flow of water in a transverse direction in the wood of trees. This isolation of the separate filaments of tracheæ in the leaf and in the stem enables the tension developed by the transpiring cells of the leaves, while it raises a column of water in one series of tracheæ, to draw down a solution in a neighbouring filament of tracheæ terminating above in some local supply. If the anatomical connexion of the two series is located in a subterranean organ the tracheæ of the subterranean organ may become filled from that supply.

So far the evidence of reversed flow in the water-conducting tracts which we have been considering has been derived from plants under artificial conditions—plants the conducting tracts of which have been cut into and otherwise interfered with. Is there any evidence that reversal of the transpiration-current normally occurs in uninjured plants?

Some recent work on the transmission of stimuli seems to me to indicate that these reversals are continually occurring in normally growing plants.

The first piece of work to which I would direct attention is that of Ricca on *Mimosa*. It has long been known that the stimulus which causes the folding of the

pinnules and the bending of the petioles of *Mimosa* could traverse portions of the petioles or stems which had been raised to such a temperature as would kill the living elements in these organs. Notwithstanding that observation, Haberlandt's view, that the stimulus is transmitted as a wave of pressure through certain tubular elements of the bast, was generally accepted as the least objectionable of any of the theories which had been put forward to explain this transmission. Ricca saw that, among other difficulties, the slowness of transmission—never more than 15 mm. per second—was a grave objection to this view. Accordingly, working with a woody species of *Mimosa*—*Mimosa Spagazzinii*—he removed the whole bast and outer tissues of the stem for as many as twenty-three centimetres and was able to show that the stimulus was still transmitted. Similarly he found that the stimulus was transmitted through narrow strips of the wood from which even the pith had been removed. These experiments and others in which the transmitting organ had been killed for a considerable length caused Ricca to recognise that the stimulus is transmitted in the wood and not in the bast, as had been previously held. Thus he was led to assign the transmission to the transpiration-current. He was able to confirm this conjecture by showing that the transmission to the various leaves of a plant is largely controlled by the rate of the transpiration from the individual leaves. Thus, other things being equal, a rapidly transpiring leaf receives the stimulus sooner than a sluggishly transpiring one equidistant from the point of stimulation. He was able to show further that the stimulus may be transmitted through a glass tube filled with water, just as it is transmitted through a dead portion of the stem. Evidently a hormone set free into the transpiration-stream is the long-sought-for mechanism by which the stimulus is transmitted throughout *Mimosa*.

As the stimulus travels both in a basipetal and acropetal direction we may assume that movement of the transpiration-stream in a downward direction is of normal occurrence in plants.

Contemporaneous with, and subsequent to, Ricca's important work on *Mimosa*, experimental evidence has been accumulating to indicate that the transmission of other stimuli—phototropic, traumatotropic, thigmotropic, and geotropic—is effected by means of the passage of a dissolved substance. Boysen-Jensen appears to have been the first to announce that phototropic and geotropic stimuli may be transmitted across protoplasmic discontinuities. Paál emphasised this by showing that these stimuli are able to pass a disc of the tissue of *Arundo donax* impregnated with gelatine, which is interposed between the receptive and responding regions. These observations rendered the view that the stimulus is transmitted in the form of a hormone extremely probable; and later Stark showed that this hormone is thermostable, just as Ricca had done in the case of the hormone of *Mimosa*. Another very interesting point discovered by Stark—working with traumatic stimuli—is that the hormones are to a certain extent specific. Thus if the perceptive tip of a seedling is removed from one plant and affixed in position on another, the certainty of the response depends on the genetic affinity of the two plants.

In all these cases it seems certain that the perceptive tissues are the point of origin, when stimulated, of a dissolved substance, the hormone, which makes its way to the motile tissues and releases the response.

In the case of *Mimosa* just alluded to, and of the labellum of *Masdevallia* examined by Oliver, there is direct evidence that the transmission of the hormone is effected by the vascular bundles. In *Mimosa* the channels are more precisely localised as being the tracheæ of the wood. Furthermore, the rapidity of transmission renders it certain that simple diffusion through the tissues of the plant will not account for the process. Some recorded velocities of transmission are here enumerated for the sake of comparison:

Plant.	Nature of Stimulus.	Transmission Time in secs. per mm.
<i>Mimosa</i>	Heat	0·07
<i>Drosera</i>	Chemical	6·00
Seedling	Light	180-300
	Gravity	300
Tendrils	Contact	17
Diffusion in tissue . . . .		2250-3600

There is thus every reason to believe that the transmission of stimuli generally through the tissues of the higher plants is effected by the conveyance of a hormone in the wood of the vascular bundles from the receptive to the motile regions, and whenever this transmission is in a downward direction evidence is afforded of the downward movement of water in the tracheæ. It is reasonable to suppose that this downward current is able to carry organic foodstuffs as well as hormones.

Thus the evidence for the existence of a backward flow of water in the tracheæ of wood, in addition to the more obvious upward stream, is convincing. With regard, however, to the mechanism by which the backward stream is supplied we have but scant information.

The volume-changes of leaves which Thoday has recorded are suggestive in this connexion. These changes he found of various magnitudes, occurring simultaneously in different or in the same leaves. They may cause a linear contraction amounting to 2·5 per cent. in ten minutes, and may produce a volume contraction of 7 per cent. in the same time. The water corresponding to this volume-change in the cells of the leaf if transmitted into the tracheæ would produce a considerable downward displacement, as may be seen from the following figures:

Name of Plant.	Volume of 1 per cent. Contraction in mm <sup>3</sup> .	Cross-section of Tracheæ in Petiole in mm <sup>2</sup> .	Downward Movement in cm.
<i>Acacia japonica</i>	22·8	0·05	45·6
<i>Solanum tuberosum</i>	28·0	0·07	40·0
<i>Syringa vulgaris</i>	42·15	0·013	16·5
<i>Acer macrophyllum</i>	42·2	0·22	19·2

If these changes in volume are caused by, or accompanied with, a development of permeability of the contracting cells, evidently a backward movement of organic substance having a velocity of about 120 cm. and more per hour would be produced.

It is possible that the tension which causes these contractions of the leaf-cells at the same time acts as a stimulus to increase the permeability of the plasmatic membranes of the cells; and so one might imagine that the development of a certain tension would automatically release organic substances from the cells and draw them through the tracheæ downwards. Direct experiment on this point presents difficulties, but it may be worth recording that when the internal osmotic pressure of the leaf-cells was overbalanced by an external gas-pressure, the water pressed from the cells and forced out of the tracheæ of the supporting stem was found to be practically pure, and if it contained carbohydrates they were in such small quantities that no reduction could be detected with Benedict's solution either before or after inversion. This experiment was repeated several times with branches of *Sambucus nigra* and *Tilia americana*. The cut branch, well supplied with water, was first exposed for several hours to conditions favourable to photosynthesis, and then either immediately or after a sojourn in darkness subjected to the gas-pressure. A pressure of thirteen atmospheres was found sufficient to drive water back from the leaves out of the stem.

Of course the conditions of this experiment are not those obtaining in the normal plant, where during transpiration the volume of a leaf, or part of a leaf, changes. In the transpiring plant we can also imagine the accumulation of a substance or an ion which would give rise to an alteration of the permeability of the plasmatic membranes of the leaves.

When, in order to imitate these conditions, the cells of the leaves in the foregoing experiment are rendered permeable by the introduction of a little toluene into the pressure-chamber, the application of a smaller pressure is sufficient to press the cell-contents into the water-channels and liquid emerges from the base of the stem which readily reduces Benedict's solution.

In the same way, if a pinna of *Sambucus nigra* is surrounded with toluene vapour, transpiration from the adjacent pinna draws back the cell-contents of the toluened pinna, and afterwards their track in the wood of the vascular bundles of the rachis may be traced by the browning of this tissue.

Another possibility presented itself, namely, that the direction of the current might act as a stimulus regulating the permeability of the cells in contact with the tracheæ. To test this, short lengths of stem set in their normal position were supplied, first through their

lower and afterwards through their upper end, with distilled water. In neither case could carbohydrates be detected in the issuing stream.

The foregoing short consideration of some recent physiological work leads us, then, to the following conclusions:

The transport of the organic substances needed in the distal growing regions is effected through the tracheæ of the wood. The substances travel dissolved in the water filling these channels, which is moved by transpiration, expansion of the growing cells, or root pressure.

Physical considerations forbid us admitting that sufficiently rapid transport can be afforded by the bast either for the observed upward or downward distribution of organic substance.

The existence of downward as well as upward movement of water in the tracheæ of the wood may be demonstrated by suitable experimental means, and may be inferred by the transport of hormones in the wood.

The occurrence of local contractions in leaves suggests that local increases of permeability supply dissolved organic substances to the distal ends of certain of the filaments of tracheæ. The tension developed by the transpiration of other regions draws these along downward as well as upward channels in the wood.

In thus ruling out the participation of the bast in the longitudinal transport of organic substances in plants one naturally is forced to speculate on its probable function. Its distribution and conformation are such that, while it possesses a very small cross-section, it appears with the other living elements of the vascular bundles, medullary rays, wood-parenchyma, etc., to present a maximum surface to the tracheæ.

This large surface may find explanation in the necessity of interchange between the living cells and dead conduits. The colloidal contents of the former render this process slow, hence the necessity for the large surface of interchange to enable sufficient quantities of organic substances to be abstracted from and introduced into the tracheæ to meet the needs of the plant.

Before concluding I would like to add that the experimental work carried out on this matter would have been quite impossible for me were it not for the assistance and ingenuity of Mr. N. G. Ball. He also has contributed materially by his criticisms and suggestions.

## Obituary.

COLONEL E. H. GROVE-HILLS, C.B.E., C.M.G., F.R.S.

COLONEL EDMOND HERBERT GROVE-HILLS, whose death occurred on October 2 at his residence at Campden Hill, W., was the son of Herbert A. Hills of High Head Castle, Cumberland. Born on August 1, 1864, he was educated at Winchester, whence in 1882 he passed into the Royal Military Academy, Woolwich. There his abilities were recognised as giving promise of a distinguished career, and he passed out as the senior cadet of his term, receiving a commission in the Royal Engineers in 1884.

Scientific subjects specially interested him, and in 1893 he was elected a fellow of the Royal Astronomical Society; in the following year a paper by him on the photographs of the spectrum of the eclipsed sun taken at the solar eclipse of April 1893 was communicated to the Royal Society. The study of solar physics strongly attracted him, and he also took part in the eclipse expeditions of 1896 to Japan, of 1898 to India, and in that of 1914 to Kieff, whence he was recalled on the outbreak of war to military service. In 1898 he took up the appointment of instructor in chemistry and photography at the School of Military

Engineering, but he had only held this for a year when he was transferred to the Topographical Section of the General Staff at the War Office. Here his scientific inclinations found full scope in the organisation of survey work in all parts of the world. During his tenure of the post he raised the standard of this work in a very notable degree, which was recognised by the C.M.G. being conferred on him in 1902. His work here brought him into contact with many problems in geodesy, in which he took a keen and lasting interest. At this time Sir David Gill was actively promoting the geodetic triangulation in South Africa, and to this Grove-Hills gave his whole-hearted support.

In 1905 he completed his period of service as head of the topographical department of the War Office, and then retired from the army. In the following year he contested Portsmouth in the Conservative interest unsuccessfully, and afterwards occupied himself mainly with scientific investigations. At the British Association in 1906 he raised the question whether the triangulation of this country was of the accuracy required by modern geodesy, and a few years later the Ordnance Survey undertook the re-observation of certain triangles in Scotland to determine this point. In the same year he and Sir Joseph Larmor discussed the movement of the pole in an important communication to the Royal Astronomical Society.

Col. Grove-Hills was president of Section E at the British Association meeting in 1908, where he discussed the surveys of the British Empire in an important address. He had before this been invited to report on the Canadian surveys and wrote a valuable and instructive report on them. In 1911 he was elected a Fellow of the Royal Society, and from 1913 to 1915 he was president of the Royal Astronomical Society. He was also latterly Secretary of the Royal Institution. Keenly interested in astronomy, he designed the suspended zenith instrument at Durham Observatory, of which institution he was Honorary Director up to the time of his death. While on his way to Kieff with the eclipse expedition of 1914 he was recalled to take his part in the Great War, and was appointed Assistant Chief Engineer of the Eastern Command, being gazetted Brigadier-General in 1918. His services in this responsible post were recognised by the award of the C.B.E. in 1919.

Endowed with very great natural ability, and a keen interest in all scientific questions, Grove-Hills combined with these great administrative ability and sound common sense. He was always ready to assist by his advice and active co-operation in any well-planned scheme of scientific work, and in his death astronomy and geodesy have suffered a severe loss.

H. G. L.

#### MAJOR-GENERAL J. WATERHOUSE.

MAJOR-GENERAL JAMES WATERHOUSE, who was eighty years of age, died on September 28. As a youth he joined the Royal Bengal Artillery, and after seven years was made Assistant Surveyor-General in charge of the photography section in the Surveyor-General's Office in Calcutta. He retired in 1897. His official duties necessitated the study of photography and

photo-mechanical methods of reproduction, and this he did with a keen eye for any possible improvement, and a skilful hand which enabled him to test the practical value of any new introduction. He made an extended continental tour during his term of office that he might become acquainted with the methods employed in foreign photographic laboratories. A considerable number of improvements were introduced by Waterhouse in photolithography and allied processes, as well as in collotype, sometimes varying methods in use elsewhere to render them suitable for a tropical climate. His knowledge of these methods in all their minutiae was very extensive, and in 1882-1885 he contributed to the *Photographic News* a series of fifty chapters on photolithography.

In 1873, when Vogel published his discovery that the sensitiveness of plates to green and red could be enhanced from a negligible to a practically useful amount by the use of certain dyes, Waterhouse was one of the very first to confirm the observation and to find other effective dyes. In 1890 he found that by the addition of thiourea to the developer the reversal of the image was so much facilitated that a very little, if any, increase of exposure was necessary. He took part in the observation of the total eclipses of 1871 and 1875, and in the transit of Venus in 1874.

On his retirement, Waterhouse studied the early history of the camera obscura, and of the action of light on silver salts, correcting some false and incomplete ideas that were current. He was president of the Royal Photographic Society from 1905 to 1907, honorary secretary of the Calcutta Zoological Gardens from 1894 to 1897, president of the Asiatic Society of Bengal from 1888 to 1890, and trustee and twice chairman of the Indian Museum at Calcutta. The value of his scientific work in connexion with photography was acknowledged by the award to him of the Progress Medal of the Royal Photographic Society, and the Voigtländer Medal of the Vienna Photographic Society.

WE regret to record the death of Prof. J. K. A. Wertheim Salomonson. He was born in 1864, passed his medical studies at the University of Leyden, and in 1899 became professor in neurology and radiology in the University of Amsterdam. His contributions to these two subjects were of considerable importance, for his range of knowledge of medicine and physics was supplemented by a perfection of skill in instrumental design. He was a frequent visitor to this country and only last year he demonstrated to the Ophthalmological Section of the Royal Society of Medicine a method for the photography of the structure of the eye. He was responsible for improvements in the electro-cardiograph and in many instruments designed for radiological purposes. A man of engaging personality, his loss will be felt over the wide circle which his scientific interests served. He was a Knight of the Order of the Lion of the Netherlands and an honorary member of the Röntgen Society. At the time of his death he held the office of rector magnificus at the University of Amsterdam.



## Current Topics and Events.

AN announcement was made in the Press on October 10 by the British Broadcasting Company concerning the conditions which, in order to obtain Post Office approval, must be fulfilled by receiving apparatus intended for use in connexion with the broadcasting services. The conditions have been framed with the view of preventing the use, in such sets, of circuits which may "regenerate" oscillations and thus cause disturbances at receiving stations within their re-radiation range. Experience has indicated the need, in the case of receiving apparatus handled by an unskilful user, for some form of control in the type and design of the apparatus of the nature which is aimed at in the specification in question; the specification accordingly should serve a useful purpose. Exception has been taken in some quarters to the provisions contained in clause 10 of the conditions above referred to, on the ground that these particular conditions conflict with the promise made by the Postmaster-General in the House of Commons on July 27 last, to the effect that the owners of "home-made" receiving apparatus and the existing licencees of imported receiving sets would be allowed to use their apparatus for listening-in to broadcasted news, music, etc. This clause provides, *inter alia*, that "All sets sold under the broadcast licence shall bear the registered trade mark of the broadcasting company and the Post Office registered number." It has consequently been assumed that the issue of licences for receiving broadcasted matter will be confined to those who procure listening sets from the broadcasting company. It appears to have been overlooked, however, that the announcement to which attention is directed above has been issued by the British Broadcasting Company and relates alone to the conditions to be fulfilled by the receiving sets which are to be offered for sale to the public by members of that corporation. No declaration has so far been made by the Post Office which in any way indicates that the Postmaster-General contemplates the adoption of a policy at variance with that which he informed Parliament it was his intention to pursue in this matter; nevertheless, it is distinctly unfortunate that, in all the circumstances of the case, an official statement has not been issued by the Post Office setting out fully and frankly what course it is intended to pursue in relation to the grant of licences generally.

THE assignment to science of the proceeds of the first performance of a great play by a leading dramatist is an act which we record with much satisfaction. The play was the remarkable tragedy "Judith," by M. Henri Bernstein, produced at the Gymnase Théâtre, Paris, on October 12, before a brilliant and distinguished assembly, which comprised ministers of State and the chief social and intellectual leaders of the city. The Paris correspondent of the *Daily Mail* states that the receipts were for the benefit of the French Confederation of Scientific Societies, and the *Times* correspondent announces

that more than 1000*l.* was raised by the performance. M. Bernstein gave his royalty as author, and Mme. Simone, who took the title part and obtained the greatest triumph of her career, devoted her fee to the same beneficent purpose. We cannot recall any like association of drama with science in Great Britain, and it is difficult to conceive of the proceeds from a first night being devoted to a scientific institution in this country. If, however, Sir James Barrie, Mr. Bernard Shaw, Mr. Oscar Asche, or any other of our leading dramatists or theatre managers should be inclined to follow the example which Paris has given us, we commend to their attention as eminently worthy of support such confederations as the British Association, British Science Guild, and the Conjoint Board of Scientific Societies.

THE August number of the *Journal of Indian Industries and Labour* contains two articles on State control in the field of industrial enterprise. Mr. C. Y. Chintamani, Minister of Education and Industries in the United Provinces, deals with the subject in an article entitled "The Limits of State Aid to Industry," with special reference to the work of the department of which he is in charge, while Mr. A. Y. G. Campbell contributes the first part of an article on the functions of provincial departments of industries in which the whole question of State assistance is reviewed. Mr. Campbell speaks from experience, as he himself held for some years the post of Director of Industries in Madras. Another feature is an extract from the presidential address delivered to the Mining and Geological Institute of India in January 1922 by Dr. Leigh Fermor, officiating director of the Geological Survey of India, in which is described the practical utility of a State geological department. Dr. Fermor declares that in royalties alone the receipts accruing annually to the Provincial Governments and other owners of mineral rights in India in respect of the eight most important minerals, excluding salt and saltpetre, amount to at least 560,000*l.* The *Journal* also contains the usual summarised accounts of the activities of the Provincial Departments of Industries during the preceding quarter.

THE council of the Institution of Mining and Metallurgy has awarded the Gold Medal of the Institution to Sir Alfred Keogh, "on the occasion of his retirement from the Rectorship of the Imperial College of Science and Technology, in recognition of his great services in the advancement of technological education and as a mark of admiration and respect." The council of the Institution of Mining Engineers has awarded the Medal of the Institution to Sir George Eilby, "in recognition of his valuable contributions to science, with special reference to his researches on fuel." The medals will be presented at the combined dinner of the two institutions to be held at Guildhall, London, on November 16, at which the Prince of Wales and several ministers of State will be present.

DR. M. O. FORSTER was entertained at dinner by a number of his chemical friends on October 6 on the eve of his departure to India to take up the duties of his new appointment as director of the Indian Institute of Science at Bangalore. He left England on October 13 by the P. and O. steamship *Morea*.

It is stated in the *Chemiker Zeitung* of September 14 that Prof. Wieland has been appointed to the editorial board of *Liebigs Annalen* in place of the late Prof. Wislicenus. The board consists, in addition, of Profs. Wallach, Graebe, Zincke, and Willstätter. In the issue of September 26 it is announced that Dr. Noddack has been appointed director of the Physikalisch-Technische Reichsanstalt.

At the inaugural meeting of the eighty-first session of the Pharmaceutical Society's School of Pharmacy, Bloomsbury Square, on October 4, the Hanbury medal, awarded every two years for the promotion of research in the chemistry and natural history of drugs, was presented to Prof. Emile Perrot, professor of materia medica in the University of Paris.

THE fifth annual Streetfield Memorial Lecture will be delivered by Prof. C. H. Desch in the Chemical Lecture Theatre of the Finsbury Technical College, Leonard Street, E.C.2, on Thursday, November 2, at 4 o'clock. The subject will be "The Metallurgical Chemist."

THE forty-fifth anniversary of the Institute of Chemistry will be celebrated by a dinner to be held at the Hotel Victoria, Northumberland Avenue, W.C.2, on Friday, November 17.

On Tuesday, October 10, members of the Circle of Scientific, Technical, and Trade Journalists accepted the invitation of Holophane Ltd. to visit the new showrooms and laboratories, where an address was delivered by Captain Stroud, and a demonstration of the latest scientific devices for distributing artificial light was arranged. In addition to standard types of reflectors for use in streets, factories, shops, etc., several interesting novelties were shown, including the new unit equipped with Chance's daylight glass to produce "artificial daylight." The appearance of coloured surfaces under this light, as compared with that of ordinary electric lamps, was demonstrated in the laboratory, where apparatus for obtaining polar curves of light distribution was also shown in operation. Mr. Leon Gaster, in returning thanks on behalf of the visitors, remarked that the scientific application of light was a subject of general interest to the technical press. Its importance was illustrated by the appointment, in 1913, of a Home Office Committee on Lighting in Factories and Workshops. It was hoped that in future each scientific advance would be brought to the notice of the technical press, which acted as an educational link between the expert and the general public.

THE seventy-sixth annual meeting of the Birmingham and Edgbaston Debating Society was held on October 4. The visitors included Alderman David

Davis (Lord Mayor of Birmingham), Dr. R. Wakefield (Bishop of Birmingham), Dr. McIntyre (Archbishop of Birmingham), Mr. C. Grant Robertson (principal of Birmingham University), Mr. C. A. Vince (president of Birmingham Central Literary Association), and Mr. Arthur Brampton (president of Birmingham Liberal Association). Mr. G. Austin Baker was elected president for the ensuing session. Mr. Harry Jackson, the retiring president, delivered an address on "The Trend of Human Development." He showed that whereas in the past the environment and progress of man was limited to tangible things, to-day it extends more and more to regions outside the immediate perceptions of the senses. The views of Einstein, as contrasted with those of Newton, are a typical example and represent a great and intrinsic mental advance. The individual with the super-sensitive faculty in some particular direction must be given the scope and opportunity for the full expression of his genius. Humanity cannot afford to let clever men wear out their genius in providing themselves with the necessities of life. The most advantageous application of national wealth will be the maintenance of those who are able to work in the higher environment of the intellect.

MR. A. RADCLIFFE BROWN has sent us a long letter complaining of the review of his book—"The Andaman Islanders"—in NATURE of July 22, p. 106. The gist of the reviewer's criticism was that Mr. Brown spoilt a good plan—namely, of stating his own observations and where they differed from those of his chief predecessor, Mr. E. H. Man—by so carrying it out as to lead the reader to suppose that Mr. Man's work was not worth much. Mr. Brown's defence is that in adopting his plan of procedure he was obeying the instructions of the Anthony Wilkins Studentship, under whose auspices his work was undertaken. The reviewer did not complain of the plan but of the method of carrying it out. Next, with regard to the reviewer's criticism of the unwisdom of adopting the *Anthropos* Alphabet of Pater Schmidt for his work in supersession of the long-established alphabet compiled by so competent an authority as Mr. A. J. Ellis, Mr. Brown writes that he has "no hesitation in accepting the *Anthropos* Alphabet as the nearest approach possible at the present time to a scientific universal alphabet." But at the same time he quotes the fact that Sir Richard Temple published a universal grammar which has not been adopted to any extent by other writers, "doubtless because of the objection they feel to giving up the system of grammar to which they are accustomed." Mr. Brown, having thus the fate of Sir Richard Temple's grammar before him and appreciating the reason for it, might have been warned of the fate awaiting the *Anthropos* Alphabet, and that the only result in the circumstances of partially adopting it in a work, which he himself says "does not deal with the languages of the Andamans," would be to puzzle, and not enlighten, the student. To the reviewer's criticism of use being made without acknowledgment of information gathered by living predecessors, Mr. Brown raises the defence that any passages bearing such an interpre-

tation must have occurred in the introduction "which was meant as such and nothing more." It certainly does not justify the "correction" of the work of highly experienced local officials with not only the people and the country before them, but also the possession of the official technical works and some of the other general books, on which Mr. Brown relies for his facts.

In a book entitled "Science and Human Affairs," which Messrs. George Bell and Sons, Ltd., will shortly publish, the author, Dr. W. C. Curtis, will recount how the conveniences of daily life and the safeguards to health have been discovered, and the possible bearing of science on human affairs in the future.

THE following catalogues, which should be useful to readers of NATURE, have just reached us: No. 95 (of Botanical and Zoological Works) from Messrs. Dulau and Co., Ltd., 34 Margaret Street, W.1; No. 216 (of Periodicals, Collections, Transactions, and Publications of Learned Societies, etc.) from Messrs. W. Heffer and Sons, Ltd., Cambridge; and No. 372 (miscellaneous, including Natural and Physical Sciences) from Messrs. Bernard Quaritch, Ltd., 11 Grafton Street, W.1.

MESSRS. LONGMANS AND Co. have in preparation, in four volumes, "A Natural History of the Ducks," by Dr. J. C. Phillips, of the Museum of Comparative Zoology, Cambridge, Mass., U.S.A., which will aim at giving an exact and detailed description of all known species of ducks, mapping their breeding and migration ranges. It will also contain full life-histories of the European and American species. The work will be illustrated in colour and in black and white by F. W. Benson, A. Brooks, and L. A. Fuertes. Vol. 1 is nearly ready for publication.

SIR RONALD ROSS is bringing out, through Mr. John Murray, a work entitled "The Great Malaria Problem and its Solution: an Autobiographical Account," which will give a complete history of the discovery of the relation between malaria and mosquitoes, showing how malaria is carried from man to man. Another book in the same publisher's announcement list is "Gardening for the XXth Century," by C. Eley, in which attention is chiefly directed to the more permanent features in gardens. The work will contain a list of selected trees and shrubs, with descriptive and cultural notes, and brief chapters upon botany and nomenclature.

### Our Astronomical Column.

MERCURY VISIBLE AS A MORNING STAR.—Mercury will reach its greatest elongation,  $18^{\circ} 38'$  west, in the early morning of October 31, and will be visible before sunrise during the period from about October 22 to November 10. The planet will rise about  $1\frac{3}{4}$  hours before the sun, and should be easily visible about an hour before the times of sunrise. Its position will be near the horizon in E. by S., and it will shine with a rosy, fluctuating light about equal to that of a first magnitude star.

The planet Saturn will be very near Mercury on about October 23, when the distance separating the two orbs will be a little more than  $2^{\circ}$ .

Telescopic observations of Mercury are much required, the exact time of the planet's rotation being doubtful. It is a good plan for those observers who do not possess equatorial telescopes to pick up the planet when it is visible to the naked eye, and to get and retain the disc in the field of view of the instrument until some time after sunrise, when it will have risen sufficiently high above the vapours near the horizon to permit the image to be well defined. Mercury certainly presents dusky markings which are capable of being followed when clear weather allows, and the planet offers a much better prospect for successful scrutiny than Venus.

COMETS.—Perrine's periodic comet, 1896 VII. and 1909 III., should now be looked for in the moon's absence. The following ephemerides are on two assumptions of the time of perihelion:

Date.	Assumed T., Oct. 3.		Assumed T., Oct. 11.	
	R.A.	Decl.	R.A.	Decl.
	h. m.		h. m.	
Oct. 19.0	7 45	$19^{\circ} 0' N.$	7 19	$24^{\circ} 0' N.$
	27.0	8 5	7 40	$18^{\circ} 7'$
Nov. 4.0	8 21	$9^{\circ} 0'$	7 56	$13^{\circ} 4'$
	12.0	8 33	8 9	$8^{\circ} 1' N.$

Search should be made near the line joining the two positions for each date.

Mr. Wood sends the following elliptical orbit of comet 1922 a:

	EPOCH 1922, JAN. 1.0.		
M	. . . . .	$0^{\circ}$	$2' 1''$
$\omega$	. . . . .	$183^{\circ} 37'$	$32''$
$\Omega$	. . . . .	$274^{\circ} 30'$	$13''$
$i$	. . . . .	$32^{\circ}$	$30' 16''$
$\log e$	. . . . .		$9.9953713$
$\log a$	. . . . .		$2.1874524$
$\mu$	. . . . .		$1'' 857$

Period about 1900 years.

Mr. Wood is at work on a more exact orbit, using photographic positions that extend to April 25 last.

THE MASSES OF VISUAL BINARY STARS.—The *Astronomical Journal*, No. 807, contains measures of the parallaxes of several binary stars made photographically at the Sproul Observatory by Messrs. J. A. Miller and J. H. Pitman. Investigation was made as to how far the irregularity of the combined image and the change in relative positions due to orbital motion between the exposures might introduce error. The probable errors seem to be quite as small as for single stars. The parallaxes deduced by other observers are tabulated as well as their own, and masses are deduced and classified according to spectral type with the following results for average mass: B 14.91; A 3.49; F 3.92; G 1.77; K 1.57; M 0.65. Only two M stars were available.

In conclusion, the advisability is pointed out of obtaining absolute parallaxes of as many binaries as possible by the relative shift of spectral lines due to different motion of the components in the line of sight. The method has already been applied to Alpha Centauri and to Castor, also to Sirius (bright star only). A list is given of 18 stars to which the method might be applied, with the amount of present and maximum differential motion. It is necessary either that both spectra should be visible or that the relative masses should be known.

## Research Items.

**GYPSY FOLKLORE.**—The new series of the Gypsy Lore Society's Journal is being actively conducted by its energetic secretary, Mr. T. W. Thompson. The last issue (Third Series, vol. 1., part 3) contains an excellent article by him on the Gypsy Grays as tale-tellers, which describes the methods by which the incidents of their stories are manipulated. This has a much wider interest than is implied by its title, and students of folk tales will find that it throws much needed light on the construction of these narratives.

**HOCKEY IN ANCIENT GREECE.**—An ancient Greek sculptured relief recently discovered in Athens, according to the *Times*, gives evidence that the Greeks played ball games other than with the hand. The relief represents six naked youths taking part in a game bearing every resemblance to modern hockey. The curved stick used may possibly supply an explanation of the singular curved object carved in relief on some of the votive offerings found at Sparta. These have been called "sickles." It is difficult to say why this implement should have been dedicated to Artemis, but the word "sickle" may have been the current slang for a boy's hockey-stick.

**ROMAN REMAINS IN LONDON.**—Recent excavations in the City have led to important discoveries. It seems to be proved that the ancient church of St. Peter's-upon-Cornhill was built inside of what was once a Roman fortress, which future investigation is expected to show was the first fortified camp of the Romans. If so, it is possible that it was built immediately after the re-establishment of order subsequent to the revolt of Boadicea. Mr. W. C. Edwards, the archaeologist in charge of these investigations, believes that during the next ten years more Roman discoveries will probably be made in the City than have been made for centuries. The excavation recently struck what is probably the most ancient wall yet found in London. At one point it is 5 feet thick, and above the footings were courses of tiles, four abreast, each 13 inches broad. Rooms were added to it with plastered walls which appear to be of imitation alabaster, the wall being overlaid with a layer of white cement, almost as thin as paper, on which designs had been painted by a very skilful artist. It is now clear that Gracechurch Street was not Roman: it probably belongs to Saxon times, and was the work of Alfred the Great.

**ARCHEOLOGY IN PALESTINE.**—Among the obligations undertaken by Great Britain in connexion with the control of Palestine is that of promoting archaeological research. It was a condition of the scheme that in the Advisory Board for Archaeology other nations should be represented. The first work which will now be undertaken is the excavation of the ancient City of David on Mount Ophel, immediately south of the existing walls of Jerusalem. Three different attempts have been made to probe the secrets of the hill, and though attended with some measure of success, practically the whole of Jebus, the original stronghold, the Palace and Millo of David, and in all probability the tombs of the Kings of Judah, await investigation. An area of ten acres has been preserved by the Administration, and this is now available for excavation. East of Jordan an immense field remains practically untouched, and many of these sites are of importance equal to that of Palestine itself. Especially at Jerash, the ancient Gerasa, there are wonderful remains of the Roman city, which show that it was one of the most imposing cities of the Roman period. The excavation of these

Palestine sites is likely to throw welcome light not only on the history of the Hebrews but on the obscure annals of the nations who preceded them, and it may be hoped that the Palestine Exploration Fund, which counts among the names of its illustrious servants that of Kitchener, will receive adequate support in carrying out the well-arranged programme of investigation which is now laid before the scientific world.

**UPPER CRETACEOUS GASTROPODS OF NEW ZEALAND.**—Certain Upper Cretaceous gastropods of New Zealand, originally referred to Mr. H. Woods for description, were on his recommendation forwarded to Dr. O. Wilckens, then at Strasbourg, to deal with. The intervention of the war and consequent removal of Dr. Wilckens to Bonn delayed the completion of the task, and the finished monograph as rendered into English by the author himself has recently been issued as Paleontological Bulletin No. 9 by the Geological Survey Branch of the New Zealand Department of Mines. The major portion of the fossils studied are of Upper Senonian age. While these include a few species peculiar to New Zealand, resemblances can be traced in many examples to species from beds of equivalent age in North Germany, Chili, Patagonia, the Antarctic Regions, and South India. Of the indigenous forms the most striking is the remarkable *Conchothyra parasitica*, and Dr. Wilckens gives a very careful account of its strange growth and development. The plates accompanying the monograph are deserving of much praise, and there is a map showing the localities whence the fossils were obtained.

**MARINE FOSSILS IN CENTRAL INDIA.**—The General Report of the Geological Survey of India for 1921 contains a confirmation, and some further particulars, of the discovery of marine fossils in the lower Gondwana series of Central India, which was reported in some of the Indian newspapers about nine months ago. The discovery, which was made by Mr. K. P. Sinor, State Geologist to the Rewah Durbar, at Umaria, situated almost centrally in the broadest part of the Peninsula, consists of a shell band, about 3 inches thick, composed almost entirely of shells of the genus *Productus*. Below the shell band are quartz grits which pass up, through the band, conformably into sandstones of Lower Barakar age, the bed itself lying not far from the junction of the Gondwana rocks with the underlying gneiss, in beds which are usually regarded as of Talchir age. The discovery has been further investigated by Mr. P. N. Mukherji, field collector of the Survey, who added two specimens of *Spiriferina* to the fauna. The *Productus* has not yet been identified, but it is new to India; the *Spiriferina* is close to, and probably identical with, *S. cristata*, var. *octoplicata*. The fossils, therefore, are not of great assistance in determining the precise age of the band, but the discovery of marine conditions in the centre of the Peninsula, where no marine rocks of later than probably pre-Cambrian age had previously been found, is of great interest and importance. Dr. L. L. Fernald, the officiating director, by whom the report is made, discusses the question of whether the sea lay mainly to the north, or the west, of the newly discovered *Productus* locality. In either case the discovery, though of interest as marking a greater extension of the sea than had been previously suspected, does not materially alter the conclusion that the Indian Peninsula is a region which has been continuously dry land throughout the whole period covered by the sequence of fossiliferous rocks.

THE DISTRIBUTION OF TEMPERATURE IN SCANDINAVIA.—The Meteorological Institute of Sweden has published an important paper and series of charts by Mr. H. E. Hamberg on thermosynchrones and thermoisochrones in the Scandinavian peninsula (*Bihang till Meteorologiska lak utagelser*, Bd. 60, 1918 (1922)). In tables and charts, founded on the observations of 232 Swedish and 83 Norwegian stations, Mr. Hamberg gives the mean annual dates at which certain temperatures reign. The temperatures are reduced to sea-level for this purpose, although Mr. Hamberg fully realises that for certain geographical uses the value of the charts is thereby lessened, and he gives two pairs of charts, spring and autumn, one for  $12^{\circ}$  C. and the other for  $0^{\circ}$  C., in which the actual temperatures are utilised. A second series of charts indicates the average number of days with a temperature above or below certain figures. The curves on these charts Mr. Hamberg terms thermoisochrones. The charts, which are small but very clear, are most useful for geographical purposes.

SPELL OF WARM WINTERS IN EUROPE.—The abnormal winter warmth recently experienced in Central Europe, embracing England, is dealt with in the *Meteorological Magazine* for September by Mr. C. E. P. Brooks, of the Meteorological Office. A chart is given showing the differences of the mean temperatures for the winter, comprised by the months December, January, and February, for the years 1911 to 1920, and the long period averages for the combined winter months, mostly covering the years 1851 to 1910. At Budapest the winters of the past ten years have on the average been more than  $4^{\circ}$  F. warmer than the normal winter. At Zürich the excess is  $2^{\circ}6$  F.; at Paris,  $2^{\circ}1$  F.; and at Kew,  $1^{\circ}8$  F. On the Atlantic sea-board the winters of the decade in question have been slightly colder than the normal. There is no appreciable difference of temperature for the rest of the year, the summer months for the years 1911 to 1920 having been, on the whole, somewhat cooler than the average. The abnormal warmth of the winters was not confined to low levels; the mean winter temperature for the ten-year period at St. Gothard, 6877 feet above sea-level, is  $1^{\circ}9$  F. above the normal. The author suggests a tentative explanation connecting the abnormal warmth with the general decrease of sunspot numbers since the nineteenth century. Taking the mean winter temperature at Greenwich for the ten-year period, 1911 to 1920, it is  $1^{\circ}5$  F. above the 60 years' average, and the mean was above the normal in 8 winters out of 10, the excess being more than  $3^{\circ}$  F. in 4 winters. In the ten-year period from 1886 to 1895 the mean winter temperature at Greenwich was  $1^{\circ}9$  F. below the normal for sixty years, and in 8 winters out of 10 the mean was below the average, the deficiency amounting to  $3^{\circ}$  F. or more in 3 winters; this is a different period from that given by the author and with an opposite effect.

GLARE FROM MOTOR HEADLIGHTS.—The descriptions of motor headlights exhibited at the meeting of the Optical Society on May 11 will be found in part 4 of volume 23 of the Transactions of the Society, together with a report of the discussion of the conditions which a satisfactory headlight should fulfil. In America these conditions are that 100 feet ahead of the car at a point 5 feet above the horizontal, the illumination must not exceed that due to a lamp of 750 candle power. The conditions laid down in this country by the Ministry of Transport relate to the width and height of the beam and place no restriction on its intensity. The reconciliation of the requirements of the driver and the pedestrian or driver he is approaching is difficult, but the general opinion of those who took part in the discussion

appeared to be that the beam should have a candle power of 3000 in a direction half a degree below the horizontal and be reduced to 500 or 600 candle power in a direction one degree above the horizontal. As the glare effect is due to contrast, it was further suggested that the car body and the road at the side of the car should be illuminated to some extent as well as the road in front.

A NEW THEORY OF VISION.—A photo-electric theory of vision has recently been put forward by Dr. F. Schanz of Dresden and has been discussed in the *Zeitschrift für Augenheilkunde*. At present it is incomplete, but according to a paper in vol. 54 of the *Zeitschrift für Sinnesphysiologie* the author hopes to fill in the gaps by work on which he is at present engaged. In outline it is as follows: Light on entering the eye is absorbed by the visual purple, which as a result emits electrons at speeds which depend on the wave-length but not on the intensity of the incident light; that is, the visual purple is photo-electric. The electrons impinge on the rods and cones and produce the sensation of light. If their velocities do not differ widely they are equalised during their passage to the rods and cones and produce a single sensation corresponding to the mean velocity; but if they differ materially the interval between their emission and their arrival at the rods and cones is not sufficient to equalise them and they produce distinct sensations. Over a range of wave-lengths of  $1 \times 10^{-4}$  cm. equalisation is produced, but if all wave-lengths over a range double this are present, the sensation of white is produced, whether the range be e.g. from 4 to 6 or from  $6$  to  $8 \times 10^{-4}$  cm.

TESTING FOR VITAMINS.—Investigators are searching actively for some chemical means of recognising the presence of the vitamins in food materials, and the discovery of such a test would enormously increase the facility of research on these elusive substances. So far all the suggestions made have failed to withstand a critical examination. In a recent paper in the *Analyst*, Messrs. Drummond and Watson point out the close relation which exists between the presence of vitamin A in fats and the well-known reaction given by liver oils, which consists in the production of a purple coloration when the oil is dissolved in an organic solvent and a drop of sulphuric acid is added. All the liver oils of mammals, birds, and fish examined by the authors gave the reaction, but they also find that it is given, although less strongly, by the body fat of some animals and by butter. In striking agreement with the behaviour of vitamin A, the power of producing the coloration is lost when a current of air is passed through the fat at  $100^{\circ}$  C. but not when the fat is heated at this temperature in absence of air. Again, when the fat is hydrolysed it remains, with the vitamin A, in the unsaponifiable fraction. Moreover, the intensity of the reaction was found to be roughly proportional to the vitamin A content of a series of fish-liver oils. The livers and fat of pigs and rats fed on diets deficient in vitamin A did not give the reaction, but this reappeared when the deficiency was made good. It is obvious that there is a close parallel between the two properties, and the authors, without claiming that the test actually indicates the presence of the vitamin, suggest "that the association may be of some significance." The necessity for this caution is indicated by the facts that although the marine diatom *Nitzschia* has been shown to be rich in vitamin A the oil extracted from this organism did not give the purple colour test with sulphuric acid. A similar negative result was obtained with plankton oil, although the reaction was given by certain marine algae.

## Tendencies of Modern Physics.

THE Swiss Society of Natural Sciences met this year at Berne on August 24 to 27. The programme of the session comprised several discussions on questions of general interest, and papers of a more special character communicated to the various sections. The work was divided between the following sections: (1) Mathematics; (2) Physics; (3) Geophysics, Meteorology, and Astronomy; (4) Chemistry; (5) Geology, Mineralogy, and Petrography; (6) Botany; (7) Zoology; (8) Entomology; (9) Palaeontology; (10) Anthropology and Ethnology; (11) Medical and Biological Science; (12) History of Medicine and Natural Science; (13) Veterinary Science; (14) Pharmacy; (15) Engineering History.

We cannot give here a detailed account of this annual event in Swiss science; we shall therefore confine ourselves to a résumé of the address of Prof. C. E. Guye, of Geneva, in opening the series of general discussions.

Taking the title, "The Tendencies of Modern Physics and the Conception of Matter," Prof. Guye first showed that modern physics was becoming more and more electromagnetic, discontinuous, and statistical. To these three characteristics, which have been sufficiently disconcerting to minds accustomed to the classical conceptions of the second half of the nineteenth century, there has now been added a fourth, of still more perplexing character, in the introduction of the principle of relativity. In adopting this principle physics has displayed a distinctly metaphysical tendency, which sometimes ventures to introduce into scientific discussion a dogmatic method of procedure. It is true that the difficulty is compensated by important advantages, resulting from the fact that the formulæ of relativity introduce more simplicity in the dynamics of very great velocities, and more unity between the various branches of physics.

After having shown how physics, like chemistry, has moved steadily along the path of discontinuity by the introduction of the atom of electricity and the theory of quanta, Prof. Guye spoke of the consequences of this discontinuity, which complicated greatly the explanation of phenomena apparently of the most simple character.

How, indeed, could one follow, by means of the equations of mechanics, the reciprocal actions of a nearly innumerable group of discontinuous elements (molecules, atoms, electrons)? This extreme complication which characterises the phenomenon, apparently so simple, when it is desired to study it intimately, led to the introduction of kinetic theories. The calculus of probabilities then came to the aid of physicists, powerless as they were to solve, by means of the equations of mechanics, the inextricable problems which were proposed to them. But the consequence of these kinetic theories is to lead us to conceive physico-chemical laws as statistical, so that we must picture physico-chemical determinism

as a statistical determinism, to which the law of great numbers imparts all the appearance of infinite precision.

The progress of physics towards electromagnetism is particularly striking. The first decisive step along this path was made by Maxwell, to whom we owe the electromagnetic theory of light, which, universally accepted as it is to-day by physicists, unites in a systematic whole the phenomena of light and of electromagnetism. But this tendency to explain physical phenomena by the laws of electromagnetism has only served to make it still more accentuated. It has even attacked the mechanics which seemed to be the immutable basis of the old physics. To-day the fundamental postulate of mechanics—*inertia*—can be satisfactorily explained in terms of the properties of an electromagnetic field, and more and more intermolecular forces appear to be of electromagnetic nature (Debye, Keesom).

But the main reason for this constant evolution of physics towards electromagnetism is the work carried out particularly in England (Rutherford's school), which has exhibited it in a most convincing fashion. The material atom itself appears to be constituted entirely of charges of electricity, positive and negative (electrons), and all physical forces, with the exception of the mysterious force of gravitation, will thus be found, in the last resort, to be electric and magnetic forces.

In the second part of his address, Prof. Guye showed how the conception of matter, as defined by *inertia*, had evolved from Lavoisier to Einstein, and to the most recent work of Rutherford and Aston. Without committing ourselves positively to Prout's hypothesis, which would make the atomic weights of the elements integral multiples of that of a unique constituent—the atom of hydrogen—new developments point to a duality of ultimate material, the positive electron which is mainly responsible for the *inertia* of the atom, and the negative electron.

In short, the startling progress realised in physics during the last thirty years has reduced to naught all those fluid phantoms which we knew—imponderable electric and magnetic fluids; only the most tenacious among them—the aether—offers still a partial resistance.

Physicists have thus been led, little by little, to the idea of the materiality of electricity, and still more the formulæ of relativity point to the parallelism between *inertia* and energy; that is, to the fusion into a single principle of the two principles which govern all physical phenomena—the principle of the conservation of mass and that of the conservation of energy.

Such are the important results, not only from the scientific point of view, but also from that of our best philosophic culture, which modern research has brought forward during the course of the last thirty years.

The Isothermal Frontier of Ancient Cities.<sup>1</sup>

THE northern frontier of the Roman Empire is shown in atlases of ancient geography, and that of the Achaemenian Empire of the Persians and of the dynasties which succeeded in the Middle East. The frontier of the ancient Chinese Empire has not been made similarly familiar, and in place of it there is the representation of the Empire of China as it

has been in mediæval and modern times. From this most of Manchuria, all Mongolia, and the Ili valley must be shorn off in order to get the Chinese northern frontier as it was under the Han dynasty in the beginning of the second century after Christ, the age of the Antonines in Europe. At this time, when the ancient civilisation of Eurasia was at the height of its culture and apparently at the maximum of its power, the northern frontier once controlled by

<sup>1</sup> Abstract of a paper by Dr. Vaughan Cornish read before Section E (Geography) of the British Association at Hull on Sept. 12.

the Persian Achæmenidæ was divided between the Parthians, capitalised at Ctesiphon, and the Kushan dynasty of the Yue-chi, capitalised at Peshawar. These four northern frontiers, Roman, Parthian, Kushan, and Chinese, were consecutive, forming an unbroken line from the mouth of the Rhine near the modern Katwyk in Holland, 52° N., to the east coast of Korea in about 41° N. South of the line a vast array of established cities stretched for seven thousand miles across Eurasia, in some parts protected by natural barriers, in others defended by lines of masonry fortification. North of the line were the tents of nomads, huts of forest dwellers, and stockaded defences of earth and wood. In the northern part of modern Germany there were territories north of the line which the Romans had abandoned as untenable or unprofitable. South of the line in Eastern Europe was the district of Dacia which Augustus preferred not to touch, but Trajan was compelled to occupy. In this country the native people had in the interval begun to construct masonry fortifications.

In the course of an investigation of the geography of capital cities, it was found that this northern frontier of ancient cities, on the eve of the barbarian irruption, has, within narrow limits of variation, the same average temperature throughout. It is a true annual isotherm, not an isotherm reduced to sea level. Along the European part is a line of modern cities with meteorological observatories. The annual temperatures of eight of these, strung out along the length, has an average of 48°·6 F. Asia is not well off for meteorological records near the line on the south, and the second table consists of a list of towns mostly under Russian rule just north of the line where proper records have been kept. It will be observed, therefore, that their temperatures are rather lower than that along the frontier of the ancient cities. The average temperature of these eight towns north of the line is 47°·4 F. A very long gap in these towns occurs between Kuldja and Mukden, but the record for the Lukchun depression in Chinese Turkestan, a little south of the frontier yields a not inconsistent figure, if corrected for the general height of the surrounding country, and that of Peking is not discordant. Further east the generalised isotherm of 48°·5 F. reaches the eastern coast of Korea in about 41° N. (somewhat north of

the peninsula portion of the country) which cannot be very far from the frontier of its ancient cities.

In the detached Roman possession of Britain the inner and principal line of fortification had its western terminal at Carlisle, where the temperature is 47°·8 F. Eastwards of the continent of Eurasia the conquest of the Japanese islands by their present masters was only completed at a much later date than that under consideration, but the Japanese derived their culture from ancient China (mainly through Korea) and it may therefore be significant that they were content to conquer, without colonising, Yezo, the northern island, and that what is reckoned by the Japanese as Japan proper, and is called by them "Old Japan" does not include Yezo but stops short with Honshiu, the mainland, and that the annual isotherm of 48°·5 F. traverses the strait of Tsugaru which separates Old Japan from Yezo.

The fact that the annual temperature along this immense line only varies within remarkably narrow limits cannot be reasonably contested. If it be the case that desiccation has occurred generally in Asia along this line since the second century of our era its probable effect would be to lessen the winter and raise the summer temperature, leaving the annual temperature much the same.

The coincidence of frontier and true isotherm is not a mere consequence of east and west barriers of mountains, inland seas, and rivers, for these had to be supplemented by long lines of fortification. Neither was it due to unsuitability of the southern country to pastoral peoples, for in Asia there was much coveted grazing land south of the settled frontier. Precisely how far this coincidence is significant it is yet difficult to say.

Annual Temperatures along the Frontier in Europe.

	° F.
Carlisle . . .	47·8
Utrecht . . .	47·8
Cologne . . .	50·2
Ratisbon . . .	46·6
Vienna . . .	48·8
Buda-Pesth . .	49·8
Debreczin . . .	49·3
Odessa . . .	48·5
Mean . . .	48·6

Annual Temperatures north of the Frontier in Asia.

	° F.
Stavropol . . .	47
Astrachan . . .	50
Kazalinsk . . .	46·5
Aulieata . . .	51·5
Narynsk . . .	44
Vyerni . . .	46·5
Kuldja . . .	48·5
Mukden . . .	45
Mean . . .	47·4

### The Mechanism of the Cochlea.

MOST medical students have probably felt that current physiological teaching provided them with only a hazy conception of the mechanism for hearing in the cochlea. Helmholtz put forward the view that this organ contained a series of resonators, which were differentiated like a set of piano strings, so that each string vibrated only in response to one particular note. It will be remembered that the cochlea forms a spiral, which when unwound consists of two chambers, placed one above the other, and separated by the basilar membrane. At one end (the base) of the cochlea, in the wall of the upper chamber, is the window which is set in vibration by the middle ear, while in the wall of the lower chamber is a similar window whose function is to prevent the pressure from changing inside the cochlea when the upper window moves. Both chambers contain fluid, and, at the other end (the apex) of the cochlea, the chambers unite, for the basilar membrane ceases just short of the apex.

The suggestion that the fibres of the basilar membrane can act as a resonating system has been

current since it was pointed out that their length (measured across the canal) varied continuously from the base to the apex. Now the fibres of a resonating system must obey the laws which govern vibrating strings, so that  $n$ , the number of vibrations of a string per sec.,  $= \frac{1}{2l} \sqrt{\frac{t}{m}}$  where  $l$  is the length of a fibre,  $t$  is the tension, and  $m$  is the mass per unit length. Gray showed in 1900 that the tension of the fibres of the basilar membrane also varied from the base to the apex, for while the spiral ligament which attached the membrane to the outer wall of the cochlea was very dense near the base, it was, on the contrary, very slender near the apex. We know, therefore, that the fibres of the basilar membrane are differentiated for tension and length, so that the short fibres near the base are under high tension, and the long ones near the apex are under low tension. To complete the requirements of the formula for vibrating strings, it is only necessary to discover a system by which the fibres are differentiated for mass, which differentiation must, as the formula

demands, be applied so that the load on the fibres is small near the base, but large near the apex.

A great difficulty in supposing that the basilar membrane represents a system of resonating strings is the fact that it is immersed in fluid. It is precisely this point which Dr. George Wilkinson, in a paper read before the Section of Physiology of the British Association at the recent Hull meeting, conceives to be, not a difficulty, but the key of the whole problem. He suggests that the differentiation of the fibres as to mass, or the "loading" of the fibres, is brought about by the fluid in the canals. When the fibres at any point of the membrane vibrate in response to an impulse from the middle ear, they will be loaded by the weight of a column of fluid proportional to the distance of the vibrating point from the *fenestra rotunda*, which is the window between the cochlea and the middle ear. The column of fluid between the window and the vibrating point will be least in the case of a point on the membrane near the base of the cochlea, and greatest in the case of a point near the apex.

So much for Dr. Wilkinson's theoretical conception. He has provided a convincing proof of his views in the shape of two very ingenious models. The first is a brass box divided horizontally into two like the cochlea unwound from its spiral. The partition which represents the basilar membrane consists of a series of parallel wires of phosphor-bronze soldered firmly in position, and covered with formalised gelatin. On this basilar membrane is scattered blue enamel powder. There is a *fenestra rotunda* and *ovalis* at one end of the box, respectively above and below the basilar membrane, the windows being formed in each case by a rubber disc. The box is filled with water and is completely closed. In his first model, Dr. Wilkinson has kept all his phosphor-bronze wires at the same tension and of the same

length. Yet he finds that when he applies a vibrating tuning-fork to the rubber membrane, or *fenestra rotunda*, the powder on the basilar membrane takes up a definite position which varies with tuning-forks of different rates of vibration. Thus a 200 D.V. fork produces a localised resonant response at a distance 3·3 cm. from the proximal end of the scale, while a 400 D.V. fork produces such a response at a distance of 0·9 cm. If one makes use of the formula for vibrating strings and supposes that the differentiation in resonance is due to the different loading of the wires by the fluid according to the above hypothesis, then the point of resonance to the lower tone should be 4 times the distance from the windows compared with that for the upper tone. Actually we see that it is not 4 times, but is  $3\cdot3/0\cdot9 = 3\cdot6$  times. A very striking agreement!

Here then is proof of Dr. Wilkinson's contention that a system of transverse fibres, immersed in a fluid as it is in the cochlea, is already, by reason of the position of the *fenestra*, differentiated for resonance in regard to the effective mass of the fibres.

In his second model, which is larger, he has carried out a differentiation of his phosphor-bronze wires in respect of tension and length. The differentiation of tension is effected by attaching weights of different sizes to the ends of the individual wires; while the lighter weights are attached to the longer fibres near the "apex," the heavier weights are attached to the shorter fibres near the base. In this way he has attained a model which gives a localised resonant response over a range exceeding four octaves.

One may say in conclusion that Dr. Wilkinson has made a very considerable contribution to our knowledge of the mechanism of hearing, and has presented the first clear conception of how the cochlea can work.

### British Association Research Committees.

RESEARCH committees to deal with the following subjects were appointed by the General Committee at the recent meeting of the British Association at Hull. The names given are those of the chairmen and secretaries of the committees.

SECTION A (MATHEMATICS AND PHYSICS).—Seismological investigations: Prof. H. H. Turner, Mr. J. J. Shaw. To assist work on the tides: Prof. H. Lamb, Dr. A. T. Doodson. Annual tables of constants and numerical data, chemical, physical, and technological: Sir Ernest Rutherford, Prof. A. W. Porter. Calculation of mathematical tables: Prof. J. W. Nicholson, Dr. J. R. Airey. Determination of gravity at sea: Prof. A. E. H. Love, Prof. W. G. Duffield. Investigation of the upper atmosphere: Sir Napier Shaw, Mr. C. J. P. Cave. To aid the work of establishing a solar observatory in Australia: Prof. H. H. Turner, Prof. W. G. Duffield.

SECTION B (CHEMISTRY).—Colloid chemistry and its industrial applications: Prof. F. G. Donnan, Dr. W. Clayton. Absorption spectra and chemical constitution of organic compounds: Prof. I. M. Heilbron, Prof. E. C. C. Baly.

SECTION C (GEOLOGY).—The Old Red Sandstone rocks of Kiltoran, Ireland: Prof. Grenville Cole, Prof. T. Johnson. To excavate critical sections in the palæozoic rocks of England and Wales: Prof. W. W. Watts, Prof. W. G. Fearnside. The collection, preservation, and systematic registration of photographs of geological interest: Prof. E. J. Garwood, Prof. S. H. Reynolds. To consider the preparation of a list of characteristic fossils: Prof. P. F. Kendall, Mr. H. C. Versey. To investigate the flora of lower

carboniferous times as exemplified at a newly discovered locality at Gullane, Haddingtonshire: Dr. R. Kidston, Prof. W. T. Gordon. To investigate the stratigraphical sequence and palæontology of the Old Red Sandstone of the Bristol district: Mr. H. Bolton, Mr. F. S. Wallis.

SECTION D (ZOOLOGY).—To aid competent investigators selected by the committee to carry on definite pieces of work at the Zoological Station at Naples: Prof. E. S. Goodrich, Prof. J. H. Ashworth. To summon meetings in London or elsewhere for the consideration of matters affecting the interests of zoology, and to obtain by correspondence the opinion of zoologists on matters of a similar kind, with power to raise by subscription from each zoologist a sum of money for defraying current expenses of the organisation: Prof. S. J. Hickson, Dr. W. M. Tattersall. Zoological bibliography and publication: Prof. E. B. Poulton, Dr. F. A. Bather. Parthenogenesis: Prof. A. Meek, Mr. A. D. Peacock. To nominate competent naturalists to perform definite pieces of work at the Marine Laboratory, Plymouth: Prof. A. Dendy (*Chairman and Secretary*). Experiments in inheritance in silkworms: Prof. W. Bateson, Mrs. Merritt Hawkes. Experiments in inheritance of colour in Lepidoptera: Prof. W. Bateson (*Chairman and Secretary*).

SECTION E (GEOGRAPHY).—To consider the advisability of making a provisional population map of the British Isles, and to make recommendations as to the method of construction and reproduction: Mr. H. O. Beckitt, Mr. F. Debenham.

SECTIONS E, L (GEOGRAPHY, EDUCATION).—To



formulate suggestions for a syllabus for the teaching of geography both to matriculation standard and in advanced courses; to report upon the present position of the geographical training of teachers, and to make recommendations thereon; and to report, as occasion arises, to Council, through the Organising Committee of Section E, upon the practical working of regulations issued by the Board of Education affecting the position of geography in training colleges and secondary schools: Prof. T. P. Nunn, Mr. W. H. Barker.

SECTION G (ENGINEERING).—To report on certain of the more complex stress distributions in engineering materials: Prof. E. G. Coker (*Chairman*), Prof. L. N. G. Filon, and Prof. A. Robertson (*Secretaries*).

SECTION H (ANTHROPOLOGY).—To report on the distribution of Bronze Age implements: Prof. J. L. Myres, Mr. H. J. E. Peake. To conduct archaeological investigations in Malta: Prof. J. L. Myres, Sir Arthur Keith. To conduct explorations with the object of ascertaining the age of Stone Circles: Sir Hercules Read, Mr. H. Balfour. To excavate early sites in Macedonia: Sir William Ridgeway, Mr. S. Casson. To report on the classification and distribution of rude stone monuments: Dr. R. R. Marett, Prof. H. J. Fleure. The collection, preservation, and systematic registration of photographs of anthropological interest: Sir Hercules Read, Mr. E. N. Fallaize. To conduct archaeological and ethnological researches in Crete: Dr. D. G. Hogarth, Prof. J. L. Myres. To co-operate with local committees in excavation on Roman sites in Britain: Sir William Ridgeway, Mr. H. J. E. Peake. To report on the present state of knowledge of the ethnography and anthropology of the Near and Middle East: Dr. A. C. Haddon, Mr. E. N. Fallaize. To report on the present state of knowledge of the relation of early palaeolithic implements to glacial deposits: Mr. H. J. E. Peake, Mr. E. N. Fallaize. To investigate the lake villages in the neighbourhood of Glastonbury in connexion with a committee of the Somerset Archaeological and Natural History Society: Sir William Boyd Dawkins, Mr. Willoughby Gardner. To co-operate with a committee of the Royal Anthropological Institute in the exploration of caves in the Derbyshire district: Sir William Boyd Dawkins, Mr. G. A. Garfitt. To investigate processes of growth in children, with the view of discovering differences due to race and sex, and further to study racial differences in women: Sir Arthur Keith, Prof. H. J. Fleure. To conduct excavations and prepare a survey of the Coldrum megalithic monument: Sir Arthur Keith, Prof. H. J. Fleure. To report on the existence and distribution of long-barrows in the Isle of Man: Prof. H. J. Fleure, Dr. Cyril Fox. To report on proposals for an anthropological and archaeological bibliography, with power to co-operate with other bodies: Dr. A. C. Haddon, Mr. E. N. Fallaize. To report on the best means of publishing a monograph by Dr. Fox on the archaeology of the Cambridge region: Dr. A. C. Haddon, Mr. H. J. E. Peake.

SECTION I (PHYSIOLOGY).—Efficiency of movement in men equipped with artificial limbs: Prof. E. P. Cathcart, Prof. A. V. Hill. Muscular stiffness in relation to respiration: Prof. A. V. Hill, Dr. Ff. Roberts.

SECTION J (PSYCHOLOGY).—The place of psychology in the medical curriculum: Prof. G. Robertson, Dr. W. Brown. Vocational tests: Dr. C. S. Myers, Dr. G. H. Miles.

SECTION K (BOTANY).—To continue breeding experiments on *E. nothera* and other genera: Dr. A. B. Rendle, Dr. R. R. Gates. Primary botanical survey in Wales: Dr. E. N. Miles Thomas, Prof. O. V. Darbishire.

SECTION L (EDUCATIONAL SCIENCE).—Training in

citizenship: Rt. Rev. J. E. C. Weldon, Lady Shaw. To inquire into the practicability of an international auxiliary language: Dr. H. Foster Morley, Dr. E. H. Tripp.

## University and Educational Intelligence.

BIRMINGHAM.—The University War Memorial, which was unveiled on Sunday, October 8, takes the form of three large panels of marble, on the eastern side of the entrance hall of the University, bearing the names of members of the University who fell in the war.

The Muirhead lectures in social philosophy are to be delivered by Prof. J. H. Muirhead, who has chosen as his subject "The Idea of Progress." The first of the series of seven is to be given on October 16. The lectures are free.

CAMBRIDGE.—The Vice-Chancellor announces a legacy of 1000*l.*, free of legacy duty, to the Agricultural Department of the University by the will of the late Charles Jewell; by the will of the late Dr. Rivers books and pamphlets have been left to the library of St. John's College, and in addition 70 volumes have been selected for the library of the Psychological Department and 295 volumes for that of the Department of Ethnology.

Mr. W. J. H. Sprott, Clare College, has been appointed demonstrator in experimental psychology.

Mr. J. C. Burkill and Mr. A. E. Ingham have been elected Fellows of Trinity College.

It is proposed to confer an honorary M.A. degree on Prof. H. R. Dean.

LEEDS.—At a Congregation of the University held on Tuesday, October 10, the Duke of Devonshire, Chancellor of the University, presiding, the following honorary degrees were conferred: *Litt.D.*: The Lord Bishop of Ripon (The Rt. Rev. Dr. Thomas Banks Strong) and Mr. Bruce Richmond, Editor of the *Times Literary Supplement*. *D.Sc.*: Sir Dugald Clerk, Sir Frank Dyson, Astronomer Royal, and Sir Richard Gregory, Editor of Nature, president of the Educational Section of the British Association, 1922. *LL.D.*: Mr. H. I. Bowring, Mr. B. Broadbent, Mr. H. McLaren, and Mr. C. F. Tetley.

Sir Dugald Clerk was presented by Prof. Smithells, who said, "In him we welcome one who came to Leeds as a member of the first chemical staff of the Yorkshire College of Science, and he returns to-day a man eminent among his fellows as a great example of the ideal on which this University has spent so much of its early labours—the harmonious and fruitful union of pure and applied science."

In presenting Sir Frank Dyson, Prof. Whiddington referred to him as "the most distinguished British astronomer," who, they remembered with pride, is also a great Yorkshireman, and in his chosen field of work has been unvaryingly successful. "Every one knows him as the Astronomer Royal, a position which in these days of astronomical discovery he has filled with the highest distinction."

Prof. Smithells, in presenting Sir Richard Gregory, said: "He stands as one of the most distinguished of those who strive to interpret science to the multitude, to obliterate the false antagonisms that have arisen between the different realms of knowledge, and to win for science her rightful place among the potent influences that act for the true enlightenment and progress of mankind."

LONDON.—Dr. C. Da Fano will begin on Wednesday, October 25, at King's College, at 4.30, a course of eight free public lectures on "The Histology of the

Nervous System." The subsequent lectures will be given on November 1, 8, 15, 22, 29, and December 6 and 13. No tickets are required.

Dr. George Senter and Mr. C. W. Crook have been elected by the science graduates to fill the two vacant seats on the Senate.

**SHEFFIELD.**—The Council has appointed Prof. A. H. Leahy to be emeritus-professor of mathematics, and Mr. R. Platt to be demonstrator in pathology and bacteriology.

DR. A. J. SUTTON PIPPARD has been appointed professor of engineering at the University College of South Wales and Monmouthshire, Cardiff.

THE Loughborough Technical College has since 1918 developed a well-equipped faculty of engineering with departments of mechanical and civil, of electrical, and of automobile engineering. In its calendar for 1922-23 (price 3s. 6d.) it claims that its own workshops enable it to provide the student with all necessary practical training concurrently with his theoretical work, thus obviating the risk, incidental to sandwich systems, of forgetting in the works what was learned in the college and *vice versa*. The college is said to have at present more than 1500 full-time day students in residence. The governors include representatives of the universities of Birmingham and Cambridge, as well as of Leicestershire County Council and Loughborough Town Council.

THE Merchant Venturers' Technical College of Bristol, in which is provided and maintained the Faculty of Engineering of the University of Bristol, has issued for the session 1922-23 a calendar (price 6d.) with 18 full-page illustrations. Like the Royal Technical College, Glasgow, it is in touch with a number of engineering firms which co-operate with it in regard to the training of apprentices, but, whereas the former arranges its engineering courses in such a way as to leave student-apprentices free to spend in their firms' works the summers intervening between the winter sessions of the college, a special feature of the Bristol "sandwich scheme" is that the student spends in the works 14 months between the first and second college (10-months) sessions. Among the free-tuition entrance scholarships of the Merchant Venturers' College is one "for the son of a citizen of Béthune who has passed either the B.-ès-L. or B.-ès-Sc. examination."

THE administration of schools in the smaller cities of the United States of America is dealt with in an interesting and stimulating way in Bulletin No. 2 of 1922 of the Bureau of Education (Govt. Printing Office, Washington, D.C., price 10 cents). The statistical basis consists of answers by 520 superintendents of education to a *questionnaire*. From the section relating to teachers' qualifications it appears that the standard requirements as regards training for teaching in elementary and in high schools respectively are two years of normal-school work for the former and four years of college work with professional courses for the latter. The United States Chamber of Commerce has lately, in a pamphlet entitled "Know and Help your Schools," given currency to the view that the work of the elementary school in forming habits and ideals being as important as the work of any other school division, the elementary school teachers should be as well trained and well paid as those of the high school, but it does not appear that many school boards have as yet adopted this view.

## Calendar of Industrial Pioneers.

**October 22, 1915.** Sir Andrew Noble died.—Widely known for his important researches on guns, projectiles and explosives, Noble was born in Greenock on September 13, 1831, and for some years served in the Royal Artillery. Joining Armstrong in 1860, he was for many years director of the ordnance works at Elswick and after Armstrong's death became the head of the great armament firm. His original investigations cover a period of fifty years, many of his memoirs being contributed to the Royal Society.

**October 24, 1903.** Samson Fox died.—The founder in 1874 of the Leeds Forge Company, Fox patented in 1877 his well-known corrugated furnace for steam boilers, the adoption of which led to the use of higher steam pressures. He first made pressed steel frames for railway wagons and was a pioneer of the acetylene industry.

**October 25, 1684.** Dud Dudley was buried.—Born in 1599, Dudley was a natural son of Edward Sutton, fifth Baron Dudley. Educated at Balliol College, Oxford, he was summoned home to superintend his father's iron works in Worcestershire, and in 1619 took out a patent for the use of pit coal instead of charcoal for smelting iron ore, an improvement in iron manufacture successfully used by Abraham Darby at Coalbrookdale in 1735. Dudley served as a colonel under Charles I. His work, "Metallium Martis," was published in 1665.

**October 25, 1903.** Robert Henry Thurston died.—A pioneer in engineering education in America, Thurston was trained as an engineer under his father and served in the navy during the Civil War. In 1870 he became professor of mechanical engineering in Steven's Institute, where he organised the first engineering laboratory in the United States; in 1880 he became the first president of the American Society of Mechanical Engineers. Removing in 1887 to Sibley College, Cornell University, he greatly extended the courses of instruction and by the time of his death the number of students had increased from 60 to 960. He was well known as a scientific investigator, and for his contributions to thermodynamics, steam engineering, and the strength of materials.

**October 28, 1899.** Ottmar Mergenthaler died.—The inventor of the linotype machine, Mergenthaler, who was born in Württemberg on May 10, 1854, emigrated to America at the age of eighteen and worked as a watchmaker with his cousin in Washington. At Baltimore Mergenthaler came into contact with the reporter Clephane, and began work on a type printing machine which, after ten years and the expenditure of a million dollars, he at last brought to a successful issue. His linotype machine was first installed in 1886 in the composing room of the *New York Tribune*.

**October 28, 1792.** John Smeaton died.—The first "Civil Engineer" and the recognised father of his profession, Smeaton, like Watt, began life under an instrument maker in London. When in business for himself he gained a reputation by his scientific papers on wind power and other subjects. Though he constructed bridges and harbours he is known principally as the builder of the Eddystone lighthouse, an original work of great importance and utility which stood on the Eddystone rock from 1759 to 1882 and now forms a monument to Smeaton on the Hoe at Plymouth. Smeaton was a fellow of the Royal Society and in 1771 founded the Smeatonian Club for engineers. E. C. S.

## Societies and Academies.

LONDON.

**British Mycological Society** (Keswick meeting), September 15-20.—F. T. Brooks: Some present-day aspects of mycology (presidential address). It is maintained that the fungi originated from protist organisms without direct relationship with the algae, and developed upon novel lines as an entirely separate and characteristic group of plants. Arguments are advanced against the view that the fungi are phylogenetically related to the green and red algae, or that they have been evolved from trans migrant seaweeds in ancient times. A monophyletic origin of the fungi is favoured. Most plant diseases are caused by fungi; hence there is need for closer co-operation between systematic mycologists and plant pathologists. Attention was directed to the inadequacy of the diagnosis of certain genera and species of pathogenic importance, and to the great influence of environmental conditions upon the growth of all kinds of fungal organisms. It is considered that mycologists and plant pathologists must be essentially botanists with the necessary fundamental training in chemistry and physics. For the plant pathologist a sense of crop values and of the important phases in the growth of crops should be inculcated.—**Somerville Hastings**: *Anellaria separata* growing in the Alps. The characters of these plants are related to the known conditions and compared with corresponding characters in phanerogams.—A. H. R. Buller: Luminosity in *Panus stypticus*. The mycelium and fruit body are both luminous, and by controlling the supply of oxygen the light can be turned on and off instantaneously. The light is given off even at or just below the freezing-point of water. Mycelium grown on wood blocks remained luminous for six months.—Miss E. M. Wakefield: Fungus-hunting in the West Indies. Observations were taken during six months spent in the Lesser Antilles and Trinidad. The characteristics of the fungus flora of these islands illustrate the distribution of fungi as affected by climate and the differences between tropical and temperate fungus floras in general.—**Carleton Rea**: Edible fungi; qualities from a gastronomic point of view of a number of the larger fungi.—M. C. Potter: Wart disease of potatoes. Preliminary experiments appear to indicate that the disease does not develop if the soil is rendered sufficiently alkaline (approximately PH 10.5).

MANCHESTER.

**Literary and Philosophical Society**, October 3.—Mr. T. A. Coward, president, in the chair.—T. A. Coward: Manchester birds, 1822-1922 (presidential address). One hundred years ago, 1822, John Blackwall, famous for his monograph on "British Spiders," read before this society a paper on "periodical" birds observed in the neighbourhood of Manchester. This list was enlarged by him in his "Researches in Zoology," and the dates of observation extended from 1814 to 1828 inclusive. Blackwall also published a list of singing-birds, and of rare visitors, and contributed to various journals notes on the habits of birds. His works prove that the local avifauna has changed but little in spite of the great increase of population and the extension of the city boundaries. A few species have vanished, others have appeared and colonised, and though few birds can now be seen in Ardwick "fields" the same species which used to occur may be met with in the parks or on the outskirts of the populated areas. The possession of open spaces, and the protection afforded by the city authorities to birds in the parks, have saved many birds from local extinction.

NO. 2764, VOL. 110]

MELBOURNE.

**Royal Society of Victoria**, July 13.—Mr. Wisewould in the chair.—H. B. Williamson: Revision of the genus *Pultenea*. Pt. III. Six new species are described: *P. Boormanii* from N.S.W., *P. Kenneyi* (Q.), *P. teretifolia* (S.A.), and three from Victoria—*P. D'Altonii*, *P. prolifera*, and *P. Readeriana*. A number of new varieties are discussed.—W. M. Bale: Two new species of Bryozoa. *Catenicella Mathewsi*: nearly allied to *C. alata* and *C. carinata*, differs from all known species in having the alae throughout uncalcified, perfectly hyaline, and apparently structureless. Alae wide, fenestrae about 12-14, small, with converging fissures. Avicularia minute, on long arm-like processes. According to Levensen's system a Pterocella. *Claviporella Goldsteini*: very close to *C. aurita*, but without the large elliptic suboral pore. Fenestrae 3, minute but distinct, with well-marked fissures. This character distinguishes it from *C. imperforata* and *C. aurita*. (The same as *Catenicella McCovi* Goldstein, *nomen nudum*, Jelly's "Synonymic Catalogue").—E. F. J. Love: Gravity determinations in Australia. By comparison of all existing material, very precise determinations of gravity for Melbourne and Sydney observatories have been obtained. Helmert's new theory of the figure of the earth—according to which the equator is slightly elliptical instead of truly circular—reconciles in great measure the observed and theoretical values of gravity at the Australian stations; there is a possible correlation between gravity at a station and the geological age of the neighbouring strata.

WASHINGTON.

**National Academy of Sciences** (Proc., vol. 8, No. 9, September 1922).—P. Franklin: The meaning of rotation in the special theory of relativity. Newtonian equations for rotation can be used to express first approximations for points near the axis of rotation. Making certain assumptions, it is shown that the spatial geometry for the rotating system depends on the time and space co-ordinates of the point considered, and that the curvature of the spatial cross-section at any space-time point in its "natural" co-ordinates is the square of the angular velocity in radians per light-second.—J. A. Eldridge: Energy losses accompanying ionisation and resonance in mercury vapour. Electrons emitted from an oxide-coated cathode traverse a region of constant potential in the experimental tube, suffering collisions with mercury vapour; they pass through two diaphragms, each pierced by a single hole, to the receiving electrode in the lower end of the tube, which is freed from mercury vapour by liquid air. A retarding potential is applied to the receiving electrode. The current is plotted against the retarding potential and it is shown that, at voltages above the ionisation point, the most important type of resonance collision involves an energy loss of 6.7 volts and also that a collision involving an energy loss of 5.7 volts occurs in mercury. In an ionising collision, the impinging electron apparently loses all its energy, and the electron produced leaves the parent atom with negligible energy.—L. W. McKeenan: Crystal structure of beryllium and beryllium oxide. Beryllium in the form of a loosely packed powder in a pyrex glass tube was submitted to X-rays from a molybdenum target. The oxide was treated similarly to detect lines due to oxide present as impurity. The fundamental space lattice for both element and oxide was found to be hexagonal.—J. P. Minton: Some cases of nerve-deafness and their bearing on resonance theories of audition. Curves are plotted

showing the relative receiver current in the testing apparatus necessary for the threshold of audition at various pitches. It is found that unless the nerve endings of the nerves are destroyed, hearing is normal if the tones are sufficiently intense. The internal ear mechanism lowers the threshold of audition but mechanical resonance of this structure is not responsible for tone perception.—C. Lundsgaard and D. D. Van Slyke: The quantitative influences of certain factors involved in the production of cyanosis. Cyanosis depends on the mean concentration of reduced haemoglobin in the blood. It is shown mathematically that 40 per cent. of venous blood must be mixed with arterial blood to obtain the necessary concentration of reduced haemoglobin. Cyanosis usually becomes perceptible when this concentration is 5 gms. per 100 c.c. of blood, but various influences may cause it to vary from 4.6 gms. per 100 c.c. of blood.

### Official Publications Received.

Recueil de l'Institut Botanique Léo Errera. Tome 10, fascicule 2. Pp. 83-156. (Bruxelles: M. Lambertin.)

Canada. Department of Mines: Geological Survey. Summary Report, 1921, Part A. Pp. 121A. Summary Report, 1921, Part D. Pp. 110D. (Ottawa.)

Canada. Department of Mines: Geological Survey. Memoir 131, No. 112 Geological Series: Kenogami, Round, and Larder Lake Areas, Timiskaming District, Ontario. By H. G. Cooke. Pp. iv+64. (Ottawa.)

Sixtieth Annual Report of the Government Cinchona Plantations and Factory in Bengal for the Year 1921-22. Pp. 4+xiii. (Calcutta: Bengal Secretariat Book Depot.) 8 annas.

Memoirs of the Indian Meteorological Department. Vol. 23, Part 5: On Cleaning and Refilling various Types of Barometer, together with a Description of several usual Patterns. By Dr. E. P. Harrison. Pp. 145-156+5 plates. (Calcutta: Government Printing Office.) 18 rupees; 2s.

Memoirs of the Indian Museum. Vol. 5: Fauna of the Chilka Lake. No. 10: The Hydrography and Invertebrate Fauna of Ramnaba Bay. By R. B. Seymour Sewell and Dr. N. Annandale. Pp. 679-710 + plates 32-43. (Calcutta: Zoological Survey of India.) 5 rupees.

1922. G. J. Mendel 1922. Hereditingsnummer van Genetica. Nederlandsch Tijdschrift voor Erfelijkheid- en Aftammingsleer. Pp. 193-384. (s'Gravenhage: M. Nijhoff.) 8 gld.

Papers from the Geological Department, Glasgow University. Vol. 5: Octavo papers from 1918 to 1921. (17 papers.) Vol. 6: Quarto papers from 1915 to 1922. (15 papers.) (Glasgow: Maclehose Jackson and Co.)

Report of the Danish Biological Station to the Board of Agriculture. xxviii, 1922. By Dr. C. G. Joh. Petersen. Pp. iv+103+5 Tables. (Copenhagen: G. E. C. Gad.)

Proceedings of the Aristotelian Society. New Series. Vol. 22: Containing the Papers read before the Society during the Forty-third Session, 1921-1922. Pp. ii+242. (London: Williams and Norgate.) 2s. net.

Year Book of the Michigan College of Mines, 1921-1922. Houghton, Michigan. Announcement of Courses, 1922-1923. Pp. 127. (Houghton, Mich.)

Public Works Department, Government of India. Triennial Review of Irrigation in India, 1918-1921. Pp. viii+232. (Calcutta: Government Printing Office.) 5 rupees.

Memoirs of the Survey of India. Vol. 15 (Supplementary to General Report 1919-20). Annual Reports of Parties and Offices, 1919-20. Prepared under the direction of Col. C. H. D. Ryder. Pp. 134+10 maps. (Calcutta: Survey General of India.) 4 rupees; 8s.

Cornell University Agricultural Experiment Station. Memoir 54: Horses Raising in Colonial New Zealand. By Deane Phillips. Pp. 883-942. Bulletin 408: Production of new Strains of Corn for New York. By C. H. Myers, H. H. Love, and F. P. Bussell. Pp. 205-268. Bulletin 409: An Economic Study of Dairying on 149 Farms in Broome County, New York. By E. G. Misner. Pp. 209-444. Bulletin 410: Effects on Insects affecting the Fruit of the Apple: with Particular Reference to the Characteristics of the Resulting Strains. By Harry Hazelton Knight. Pp. 445-498+42 plates. (Ithaca, N.Y.)

### Diary of Societies.

MONDAY, OCTOBER 23.

INSTITUTION OF MECHANICAL ENGINEERS (Graduates' Section), at 7.—R. D. Gauld: Some Factors in the Design of Steam Locomotives. ROYAL SOCIETY OF MEDICINE (Odontology Section), at 8.—W. R. Adams: Some Considerations for Preventive Dentistry (Presidential Address).

TUESDAY, OCTOBER 24.

ROYAL SOCIETY OF MEDICINE (Medicine Section), at 5.30.—Dr. Newton Pitt: Presidential Address.—Major-Gen. Sir John Moore and others: Glanders and Anthrax. ZOOLOGICAL SOCIETY OF LONDON, at 5.30.—The Secretary: Report on the Additions made to the Society's Menagerie during the months of June, July, August, and September 1922.—Exhibition of Photographs of Zebras and Oryx from Kenya.—E. T. Newton: Exhibition of a Tanned Skin of a Frog.—R. H. Burne and Prof. J. P. Hill: The Fossil Membranes of Chironomus. R. Kirkpatrick and Dr. J. Metzelaar: An Instance of Commensalism between a Hermit-Crab and a Polyzoon. INSTITUTE OF MARINE ENGINEERS, Inc., at 6.30.—Views Illustrating Industrial Works: Relations Between Poles.

WEDNESDAY, OCTOBER 25.

NEWCOMB SOCIETY (at 17 Fleet Street), at 5.—E. A. Forward: Simon Goodrich and his Work as an Engineer. Part I. 1796-1810. FELLOWSHIP OF MEDICINE (at 1 Wimpole Street), at 8.30.—Dr. E. Pritchard: The Feeding of Infants from Birth to the End of the Second Year.

THURSDAY, OCTOBER 26.

CHEMICAL SOCIETY (at Institution of Mechanical Engineers), at 8.—Sir W. H. Bragg and Prof. W. L. Bragg: The Significance of Crystal Structure. ROYAL SOCIETY OF MEDICINE (Urology Section), at 8.30.—Sir John Thomson: Work on Relations of Calcified Abdominal Glands to Urinary Surgery (Presidential Address).

FRIDAY, OCTOBER 27.

ROYAL ASTRONOMICAL SOCIETY, at 5.—Geophysical Discussion on the Maintenance of the Earth's Electric Charge. Chairman: Sir W. H. Bragg. Speakers: Dr. G. C. Simpson, C. T. R. Wilson, and Sir A. Schuster.

ROYAL SOCIETY OF MEDICINE (Study of Disease in Children Section), at 5.—Dr. E. Pritchard: Rickets (Presidential Address). PHYSICAL SOCIETY OF LONDON, at 5. INSTITUTION OF MECHANICAL ENGINEERS, at 6.—Adjourned Discussion on Paper by Prof. A. Rateau: The Use of the Turbo-Compressor for attaining the greatest speeds in Aviation. JUNIOR INSTITUTION OF ENGINEERS, at 7.30.—Question and General Discussion Evening.

ROYAL SOCIETY OF MEDICINE (Epidemiology and State Medicine Section), at 8.—Dr. J. Ewart: Economics and Tuberculosis. ROYAL PHOTOGRAPHIC SOCIETY OF GREAT BRITAIN, at 8.—Dr. G. H. Rodman: Familiar Flowers in Monochrome. ROYAL SOCIETY OF MEDICINE (Electro-Therapeutics Section), at 8.30.—Dr. R. Knox: Cardiac Diagnosis: A Survey of the Development of Physical Methods (Presidential Address).

### PUBLIC LECTURES.

SATURDAY, OCTOBER 21.

HORNMAN MUSEUM (Forest Hill), at 3.30.—Miss M. A. Murray: The Nile in the Life and Religion of the Ancient Egyptians.

MONDAY, OCTOBER 23.

ROYAL COLLEGE OF SURGEONS OF ENGLAND, at 5.—Prof. Shattock: Specimens illustrating Carcinoma. CITY OF LONDON Y.M.C.A. (186 Aldersgate Street), at 6.—Sir Walter Morley Fletcher: Man's Body and the Making of Athletic Records.

TUESDAY, OCTOBER 24.

SCHOOL OF ORIENTAL STUDIES, at 5.—Prof. Alice Werner: Some Bantu Tribes of the Tanganyika Territory. Succeeding Lectures on November 7, 21, December 6 and 13. GRESHAM COLLEGE, at 6.—Sir Robert Armstrong-Jones: Physic. Succeeding Lectures on October 25, 26, 27.

WEDNESDAY, OCTOBER 25.

KING'S COLLEGE, at 4.30.—Dr. C. Da Fano: The History of the Nervous System. Succeeding Lectures on November 1, 8, 15, 22, 29, December 6 and 13. SCHOOL OF ORIENTAL STUDIES, at 5.—Mrs. Rhys Davids: How to find the Real Founder of Buddhism. II. UNIVERSITY COLLEGE, at 5.30.—A. Lloyd-Jones: The Phonetic Structure of the Yoruba Language.—L. S. Janes: The Organisation of a Great Library.

THURSDAY, OCTOBER 26.

CITY Y.M.C.A. (186 Aldersgate Street), at 6.—Sir C. Hercules Read: The Ancient Briton as Artist and Craftsman.

FRIDAY, OCTOBER 27.

ROYAL COLLEGE OF SURGEONS OF ENGLAND, at 5.—Sir Arthur Keith: Results following Resection of the Bowel, illustrated by Experimental Work done by Mr. T. Gray on Cats. UNIVERSITY COLLEGE (in Botany Department), at 5.—Prof. A. H. R. Buller: Studies in the Morphology and Physiology of Fungi. Succeeding Lecture on November 3.—At 5.15.—Prof. J. Adams: The New Individualism in Education. BEDFORD COLLEGE FOR WOMEN, at 5.30.—J. M. McGregor: Social Life in Athens, as illustrated by Plato.

SATURDAY, OCTOBER 28.

HORNMAN MUSEUM (Forest Hill), at 3.30.—F. Balfour-Browne: The Life and Habits of Mason Wasps.

# NATURE

A WEEKLY ILLUSTRATED JOURNAL OF SCIENCE.

*"To the solid ground  
Of Nature trusts the mind which builds for aye."*—WORDSWORTH.

No. 2765, VOL. 110] SATURDAY, OCTOBER 28, 1922 [PRICE ONE SHILLING

Registered as a Newspaper at the General Post Office.

[All Rights Reserved.

## BALANCES & WEIGHTS



**F.E. BECKER & CO**  
W & J. GEORGE (LONDON) LTD PROPRIETORS  
17 TO 29 HATTON WALL, LONDON, E.C.1.

## REYNOLDS & BRANSON, Limited.

Manufacturers of Laboratory Fittings and Furniture,  
Chemical Apparatus and Chemicals.  
"RYSTOS" CHEMICAL BENCH, as supplied to the National Physical  
Laboratory, Teddington, and important Chemical Works throughout  
the country.

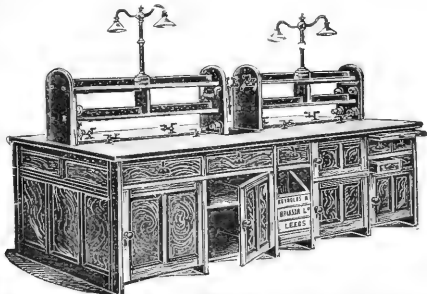

CHEMICAL, PHYSICAL, and TECHNICAL LABORATORIES fully  
equipped with Balances, Burettes, Fume Chambers, Apparatus,  
Chemicals, A.R. Reagents, etc.  
Designs and quotations submitted by application.  
14 COMMERCIAL STREET, LEEDS.

## SPECTROMETERS

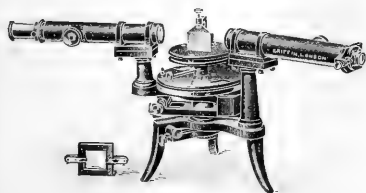

Particulars and Prices on application to—

**JOHN J. GRIFFIN & SONS, LTD.**

Kemble Street, Kingsway,  
London, W.C.2.

NOV 10 1922

**CERTIFICATE**  
OF  
**EXAMINATION**  
OF  
Fahrenheit Thermometer No. 21050, etc.

Name of Thermometer— *Regatta 21050.*

Correction to be applied to the Scale Readings determined by comparison with the Standard No. 21000 at the National Physical Laboratory, Teddington. The correction is given in the margin:—

Reading	Correction
21.0	0.0
30.0	0
40.0	0
50.0	+1
60.0	+1
70.0	0
80.0	0

Note 1. When the scale of the thermometer is graduated in degrees Fahrenheit the scale reading is given in the margin.

Note 2. The correction to be applied to the scale reading is to be added to the scale reading.

Note 3. The thermometer is not to be used for the purpose of measuring the temperature of any liquid or gas in the presence of the atmosphere unless the thermometer is first calibrated in the air at the same temperature as the atmosphere to be measured. Further the liquid in the thermometer should be the same as the liquid in the atmosphere to be measured.

On 11th July 1922.  
A. C. C. S. 21050.

J. J. Griffin & Sons, Ltd.  
London, W.C.2.

NEGATIVE CAMERA

NEGATIVE CAMERA

**FINSBURY TECHNICAL COLLEGE.**

LEONARD STREET, CITY ROAD, E.C.2.

**STREATFEILD MEMORIAL LECTURE.**

The fifth annual Lecture will be delivered by Professor CECIL H. DESCH, D.Sc., Ph.D., F.I.C. (the University of Sheffield), in the Chemical Lecture Theatre of the College, on Thursday, November 2, 1922, at 4 P.M. Subject: "THE METALLURGICAL CHEMIST." A. CHASTON CHAPMAN, Esq., F.R.S., President of the Institute of Chemistry, will preside.

**UNIVERSITY OF LONDON.**

A Course of eight Lectures in Physiology on "SECRETION AND INTERNAL SECRETION," will be given by Professor SWALE VINCENT, LL.D., D.Sc., M.D., F.R.S.E., F.R.S.C. (Professor of Physiology in the University), in the Physiological Lecture Theatre, MIDDLESEX HOSPITAL MEDICAL SCHOOL, Union Street, W.1, on Mondays and Thursdays, November 6, 9, 13, 16, 20, 23, 27, and 30, at 5 P.M. Admission free, without ticket.

EDWIN DELLER, Academic Registrar.

**NATIONAL UNION OF SCIENTIFIC WORKERS.**

25 VICTORIA STREET, WESTMINSTER, S.W.1.

The main object of the Union is to secure in the interests of national efficiency that all scientific workers are given the fullest opportunity of working up to the limit of their capacity in the service of the community.

There are now eighteen branches of the Union. They include those formed by:

- (i) University Scientific Staffs and Research Workers and Scientific Staffs in other teaching institutions;
- (ii) Government Scientific and Technical Staffs;
- (iii) Scientific workers in Industry.

The General Secretary of the Union will be pleased to arrange for members of the Executive to address meetings of industrial, Government departmental, or university scientific workers, on the work of the Union.

A list of members and the Annual Report for the year 1920-21 will be sent on application to

THE GENERAL SECRETARY,

at the above address.

**BATTERSEA POLYTECHNIC.***Principal*—\* ROBERT H. PICKARD, D.Sc., F.R.S.

University Courses, day and evening, under Recognised Teachers of the University of London are provided in Science, Engineering and Music. CHEMISTRY.—\* J. KENYON, D.Sc., F.I.C.; \* J. L. WHITE, D.Sc. PHYSICS.—\* S. MARSH, B.Sc., Ph.D.; \* A. E. EVANS, B.Sc.; \* J. F. PHILLIPS, B.A., B.Sc. MATHEMATICS.—\* F. M. SANELBY, M.Sc., B.A.; \* F. W. HARVEY, B.Sc., M.A.; \* W. G. DICKLY, M.Sc. MECHANICAL AND CIVIL ENGINEERING.—\* W. E. M. CYRNOUR, M.Sc., B.Eng.; \* J. B. SHAW, A.R.C.S., Wh.Eng.; \* H. M. EDMOND, B.Sc.; \* V. C. DAVIES, B.Sc., A.M.I.Mech.E. ELECTRICAL ENGINEERING.—\* A. T. DOVER, M.I.E.E., A.Am.I.E.E.; \* H. C. MANS, A.M.I.E.E. MUSIC.—\* H. D. WETTON, Mus. Doc., F.R.C.O.

\* Denotes recognised teacher of University of London.

There are also:—

Day Technical College in Engineering and Science. Day Training College of Domestic Science. Day Department of Hygiene and Physiology. Day School of Art and Crafts. Evening Courses in Engineering, Chemistry, Physics, Mathematics, Bacteriology, Chemical Engineering, Hygiene and Physiology, Art, Matriculation Subjects, Domestic Economy, Music, Physical Training. Hostels for Women Students. Large playing fields at Merton.

**UNIVERSITY OF DURHAM.**ARMSTRONG COLLEGE,  
NEWCASTLE-UPON-TYNE.**LECTURER IN ELECTRICAL ENGINEERING.**

APPLICATIONS are invited for the above post. Salary £300 per annum. Appointment for one year which may be extended.

Duties to commence as soon as possible. Last date for application, October 30. Further particulars may be had on application to the REGISTRAR, Armstrong College.

**ANALYTICAL CHEMIST.**

Wanted for a Dublin Laboratory an ASSISTANT CHEMIST with experience of general analytical work. State age, qualifications, experience, and salary expected. Box F 1003, KENNY'S Irish Advertising Headquarters, Dublin.

**CHELSEA POLYTECHNIC,**

CHELSEA, S.W.3.

Day and Evening Courses in Science under Recognised Teachers of London University.

- I. **INDUSTRIAL CHEMISTRY DEPARTMENT.**  
Technical Courses in Analytical and Manufacturing Chemistry, Pharmacy, Food and Drugs, A.I.C. Courses, Metallurgy, Assaying, Foundry Work, Research.
- II. **INDUSTRIAL PHYSICS DEPARTMENT.**  
Practical work in General Physics, Applications to Industries, Metrology, Calorimetry, Illumination, Acoustics, Electrical Measurement, Research.
- III. **BIOLOGICAL AND GEOLOGICAL DEPARTMENT.**  
Courses for B.Sc., etc., in Botany, Geology, Mineralogy, Zoology, Special Courses in Bio-chemistry, Rio-physiology, Bacteriology, Physiology, Hygiene, Entomology, Plant Pathology. Course for Tropical Planters, Research.

SIDNEY SKINNER, M.A.,  
Principal.

Telephone: Kensington 899.

**THE UNIVERSITY COLLEGE OF SOUTHAMPTON.****LECTURESHIP IN MATHEMATICS.**

The Council invites applications for a LECTURER in MATHEMATICS (male). Salary £300, subject to University Teachers' Pension Scheme. Applications with testimonials should be sent before October 30 to the REGISTRAR, from whom further details may be obtained. The Candidate elected will be required to enter upon his duties in January.

**CHESHIRE COUNTY COUNCIL.**

Applications are invited for the post of LECTURER in BIOLOGY at the Cheshire School of Agriculture, Reaseheath, Nantwich. Salary £250 to £300 per annum (with board lodging) according to experience.

Particulars and forms of application (to be returned by November 2, 1922) from PRINCIPAL, Cheshire School of Agriculture, Reaseheath, Nantwich.

F. F. POTTER, Director of Education.

**WANTED TO PURCHASE: Second-hand**

copies of Monographs of Coal Measure Plants, particularly those by Zeiller. State price and particulars to Box 24, c/o NATURE Office.

**X-RAY INSTALLATION, complete modern**

outfit with 12" Coil, Turbine beam, switchboard, measuring instruments, couch with tube box and screen holder, 1 Mammoth tube, 1 Water-cooled tube, 2 Valve tubes, Platinocyanide screen, all accessories. Condition as new. Cost over £230. Price £120. Can be seen at:

W. EDWARDS &amp; CO., 8a ALLENDALE ROAD, DENMARK HILL, S.E.5.

\*Phone: BRIXTON 746.

**ACCURATE CHEMICAL THERMOMETERS.—**

110° C., 150° C., 250° F., 300° F., 25.; 200° C., 25.6d.; 350° C., 400° F., 35.; 500° C., gas-filled, special glass, 10s. Beckmann Thermometers with Auxiliary Scale, 7/8 C., 1/2s. 6d. each.—(BERKLI, Chesham.

**The Misses FARRAN**

10 Bell Yard, Temple Bar, W.C.2.

**HAVE CONSIDERABLE EXPERIENCE IN  
COPYING SCIENTIFIC MS.**AND ARE PREPARED TO  
UNDERTAKE ANY QUANTITY.**NOTICE.**

The Publishers of NATURE will be pleased to send on receipt of a postcard a list of the Steel and Photogravure Portraits contained in the "Scientific Worthies" series.

ST. MARTIN'S STREET, LONDON, W.C.2.



SATURDAY, OCTOBER 28, 1922.

CONTENTS.

	PAGE
Acoustic Research . . . . .	565
The Body Temperature of Birds. By Prof. Sutherland Simson . . . . .	566
Prof. Eddington's Romanes Lecture. By E. Cunningham . . . . .	568
The Marketing of Whole Milk . . . . .	570
Our Bookshelf . . . . .	570
Letters to the Editor :—	
Relativity and Physical Reality—Dr. Alfred A. Robb, F.R.S. . . . .	572
The Miraculous Draught of Fishes—an Explanation.—Prof. E. W. Gudger . . . . .	572
Arabic Chemistry.—E. J. Holmyard . . . . .	573
On the Occurrence of the Archiannelids, Saccocirrus and Protodrilus, on the South and West Coasts of England.—Dr. J. H. Orton . . . . .	574
Origin of the Name of the Genus Masaris.—E. W. Adair; F. A. B. . . . .	574
American Research on Acoustics. (Illustrated.) By Alan E. Munby . . . . .	575
The Galactic System.—II. By Dr. Harlow Shapley . . . . .	578
Current Topics and Events . . . . .	581
Our Astronomical Column . . . . .	584
Research Items . . . . .	585
The Hydrogen Molecule. (Illustrated.) . . . . .	587
Athletics and Oxygen Supply . . . . .	588
The Fiftieth Anniversary of the Dutch Zoological Society . . . . .	589
Processes of Rock-Formation . . . . .	589
University and Educational Intelligence . . . . .	590
Calendar of Industrial Pioneers . . . . .	591
Societies and Academies . . . . .	591
Diary of Societies . . . . .	592

Editorial and Publishing Offices :

MACMILLAN & CO., LTD.,

ST. MARTIN'S STREET, LONDON, W.C.2.

Advertisements and business letters should be addressed to the Publishers.

Editorial communications to the Editor.

Telegraphic Address: PHUSIS, LONDON.

Telephone Number: GERRARD 8830.

NO. 2765, VOL. 110]

Acoustic Research.

THE work of men of science has laid the foundation for a great many improvements in the technique of building, and this is, perhaps, most directly evident in the domain of physics. The utilisation of energy in the forms of heat and electricity form striking examples, but little has been done in this country in connexion with the control of sound. This is somewhat curious since in the late Lord Rayleigh we possessed one of the greatest exponents of acoustics. With the present-day congestion of our towns, which seems to be an inevitable factor in the progress of civilisation, the reduction of noise becomes of constantly increasing importance, and the present financial loss due to this cause must be very great, though probably impossible to estimate. Need also exists for investigation on the most efficient means of propagating sound in order to secure its most effective transmission and reflection.

The production of an acoustically successful auditorium is frequently of paramount importance in connexion with architectural design. Many of our public buildings erected by eminent architects show considerable faults in this direction, and as we may assume that these faults are not due to professional apathy, it would seem that the laws regulating the production of a successful building for hearing and speaking have yet to be worked out.

Unfortunately, the variations in the factors which have to be considered are many, and no two designs are wholly identical. Some opinions on this subject have recently been stated in the public press in connexion with the hall of the London County Council building, and the views expressed suggest that men of science are agreed that there is work to be done, and also need for work already done to be reduced to a form capable of absorption by the designer and constructor. Sir William Pope considers that quite a small expenditure of time and money would suffice to provide knowledge enough to enable an architect to render every hall acoustically perfect, but this view is evidently not shared by Sir Joseph Larmor; and others will be found who regard the subject as less easy of solution than might appear from the consideration of simple cases only.

Nor is the acoustic efficiency of public halls by any means the conclusion of the whole matter. There are more numerous cases in which the direct absorption of sound is of as great importance as is transmission in auditoria. In the hospital ward, the private sick-room, and in the office, where quiet and ventilation are so often incompatible, the best means of destroying unwanted sounds calls for scientific investigation.

That architects are not entirely indifferent to this subject is shown by the fact that on the formation of the Department of Scientific and Industrial Research several years ago, the Royal Institute of British Architects formally directed attention to the need for acoustic experiments, associated with design and construction.

This need is recognised elsewhere, as is evidenced by the work done in America where, at Geneva, Illinois, in the laboratory of acoustics built for the late Prof. Sabine by Col. Fabyan, much valuable research has been carried out. Before his death in 1919 at the age of fifty, Prof. Sabine had collected a great deal of experimental data on sound in relation to materials, and his researches had sufficiently impressed themselves on American architects more than twenty years ago to result in consultations on acoustic design. The laboratory is now under the direction of Prof. Paul E. Sabine, some of whose recent researches are referred to elsewhere in this issue with a brief description of his laboratory. In this building, devoted solely to acoustic problems, the difficulties of adequate sound transmission and suppression are constantly being investigated. Work of this nature must eventually prove a valuable national asset by preventing wasted effort and expenditure, and the example of America is worth serious consideration in this country.

There are a great many problems in which the work of the man of science can materially assist the architect, not only in acoustics but also in the use of materials for construction generally, but if science is to have its due appreciation it must supply information of a practical and simple kind which will appeal to workers in a field already so wide that they have little time for the study of theory, however interesting.

### The Body Temperature of Birds.

*A Study of the Body Temperature of Birds.* By Alexander Wetmore. Smithsonian Miscellaneous Collections, Vol. 72, Number 12. (Washington, D.C., U.S.A.: Smithsonian Institution.)

WITH regard to body temperature, animals are divided into two great groups, namely, warm-blooded and cold-blooded, the former including mammals and birds, the latter reptiles, amphibians, fishes, and all invertebrates. A more accurate distinction than the actual temperature, however, is based on the fact that the so-called warm-blooded animals have a constant temperature (homoiothermal) while the cold-blooded animals have a variable temperature which is practically the same as that of the environment in which they live (poikilothermal).

The essential difference between these two groups is, that homoiothermal animals—mammals and birds—possess a heat-regulating mechanism by means of which the heat production and heat loss are so balanced that the body temperature remains practically constant, while poikilothermal animals—all others, except mammals and birds—possess no such mechanism.

Although much time and research have been devoted by a host of investigators to the study of body temperature and heat production in mammals, comparatively little attention has been given to this field in avian physiology, and all interested in this much-neglected subject will be greatly indebted to the author of the above monograph for his important and valuable contribution.

The investigation covered a period extending from January 1912 to October 1919, and records were obtained from 1558 individuals of 327 species of birds distributed among 50 families. It was carried on within the limits of the United States of America, and all the year round, in temperate regions where the extreme cold of winter is not encountered. In addition to the 327 species examined by the author personally, the previously published records from 89 others are given in the form of a supplementary table, so that definite statements may be found in the work regarding the body temperature of 416 species of birds. A table giving the individual records in detail, not included because of the high cost of printing, is deposited in the files of the Smithsonian Institution of Washington, and may be consulted by those interested.

Specially constructed thermometers of the clinical type but with a wider range—95° F. to 115° F.—were used. When a bird was shot a temperature reading was taken from the large intestine reached through the anus or from the proventriculus through the mouth, only when the specimen could be secured immediately. If there was any delay in retrieving a correct reading could not be made, so that it was only possible to secure records from less than half the birds collected. In the short time that intervened between the shooting and introduction of the thermometer, it is assumed that no appreciable loss of heat from the body took place, and that the figure recorded indicates the temperature immediately before death.

With regard to the diurnal rhythm of body temperature found in all homoiothermal animals, including man, the author was able to corroborate the work of previous observers, and it is particularly interesting to note that in nocturnal birds, such as owls, the normal rhythm is reversed, the temperature being highest during the night (period of activity) and lowest during the day (period of rest).

Hilden and Stenback found that by imposing an



artificial night (period of darkness) and day (period of artificial illumination) on birds confined in a darkened room the temperature rhythm was altered. After the second day the diurnal birds adapted themselves to the changed conditions so that the maximum temperature occurred at night and the minimum during the day. When the experiment was ended and birds again led a normal life in relation to daylight, the diurnal rhythm quickly returned. A similar change of rhythm has been produced artificially in the monkey. This bears on the question as to the cause of the diurnal temperature rhythm in animals. Some believe that there exists in the body a fixed periodicity of which the temperature rhythm is an expression, and that this periodicity persists under all conditions, and is, to a large extent, independent of outside influences. Others are inclined to question the existence of this mysterious periodicity, and look upon the diurnal variation as being due entirely to the action on the body of the various outside influences which affect body temperature, notably, muscular activity and sleep. The fact that the rhythm may be altered by changing the daily routine appears to give support to the latter view.

Although a distinct diurnal body temperature rhythm is found in birds with a wider range in many cases than in mammals, there is little evidence of a seasonal variation. This is all the more interesting, since no class of non-hibernating homoiothermal animals show greater evidence of cyclical bodily changes than do birds. During moulting time, in the late summer and autumn, they shed their feathers and show other signs of depressed vitality, while in the spring, in preparation for the mating and breeding seasons, they put on fresh plumage and become extremely active. However, heat production, if not greatly increased in a short time, has no relation to body temperature.

As in the case of mammals, the temperature of the female was found to be slightly higher than that of the male of the same species and under the same conditions, in most cases, but in certain groups the opposite was found. For example, in the herons (*Ardeidæ*), in three species we have the following averages: Great blue heron (*Ardea herodias*), male,  $104^{\circ}\cdot 8$  F., female,  $103^{\circ}\cdot 7$  F. snowy heron (*Egretta candidissima*), male,  $104^{\circ}\cdot 8$  F., female,  $104^{\circ}\cdot 0$  F.; and the black-crowned night heron (*Nycticorax naevius*), male,  $103^{\circ}\cdot 5$  F., female,  $102^{\circ}\cdot 6$  F. Here there is a very pronounced difference in favour of the male, and the same is found in certain other shore birds.

Among other factors that influence the body temperature of birds it was observed that large masses of food, if cold, will frequently cause a sudden fall in tempera-

ture in a bird of small size, while bathing may produce a slight fall.

As in the case of mammals, nestlings and immature birds show a lower temperature and a wider variation than adults, due to the fact that the temperature control is less perfect. In a black-necked stilt (*Himantopus mexicanus*), one day old, a temperature as low as  $95^{\circ}\cdot 3$  F. was recorded. Apparently this applies only to species with altricial offspring; it is not found in birds with precocial young, where the mechanism of temperature control is well organised at birth.

In considering the method of temperature control in birds, Mr. Wetmore believes, with Soum, that the air-spaces play an important rôle in the regulation of heat loss. On account of the feather covering and the absence of cutaneous glands, little heat is lost by radiation and evaporation from the skin. This throws an increased burden on the respiratory system, supplemented by the ostial spaces, and the regulation of heat loss through this channel is the chief factor in avian temperature control. The author brings forward some first-hand evidence in favour of this belief.

Discussing the significance of temperature control in general, the statement is made that "In the bird, the regulation of body temperature has reached its highest point, though birds stand second to mammals from an evolutionary point of view. Proof of this is found in the fact that birds have the highest body temperatures known, and that none of them hibernate." This conclusion scarcely seems justifiable on the evidence at hand. The degree of heat control of any species is not to be measured by the actual height of the body temperature, but rather by its diurnal variation, and according to this standard the regulation of body temperature appears to have reached its highest point in *Homo sapiens*, since the diurnal range in him is less than in any other so-called homoiothermal animal so far investigated, although the actual body temperature is among the lowest for mammals and far below that of any of the birds.

It is generally held that the higher the bird in the zoological scale, the greater is the body temperature. The author agrees with this statement, as a rule, but points out many discrepancies. If the appended tables be examined it will be noticed that, when arranged by families, the highest temperatures are found in pigeons, cuckoos, woodpeckers, and in the great passerine order beginning with the Tyrannidæ and ending with the Turdidæ. In five species of the former the average body temperature for male or female was  $110^{\circ}$  F. or more. The highest average temperature for both sexes was found in the western pewee (*Myiobanes richardsoni*) with a mean of  $110^{\circ}\cdot 2$  F., the greatest single individual reading being  $112^{\circ}\cdot 7$  F. Contrary to popular belief,

it was found that the swallows, as a group, possess the lowest average body temperature. In seven species examined in this family one alone, the rough-winged swallow (*Stelgidopteryx serripennis*), showed an average greater than 107°·5 F. Humming birds also, "with their tiny bodies seem to have a considerable range in temperature, but as a whole fall low in body warmth."

The volume is an important monograph, containing much valuable data, and it is a noteworthy contribution to this field of avian physiology.

SUTHERLAND SIMPSON.

### Prof. Eddington's Romanes Lecture.

*Pour comprendre Einstein.* Par l'Abbé Th. Moreux. Pp. 245. (Paris: G. Doin, 1922.) 7 francs.

*Die Grundlagen der einsteinschen Relativitätstheorie: Eine kritische Untersuchung.* Von Prof. Dr. H. Strasser. Pp. 110. (Bern: Paul Haupt, 1922.) n.p.

*Philosophy and the New Physics: An Essay on the Relativity Theory and the Theory of Quanta.* By Prof. Louis Rougier. Authorised translation from the author's corrected text of "La Matérialisation de l'énergie," by Prof. Morton Masius. Pp. xv + 159. (London: G. Routledge and Sons, Ltd., n.d.) 6s. net.

*Le Principe de la relativité et les théories d'Einstein.* Par Prof. L.-G. du Pasquier. Pp. xvi + 511. (Paris: G. Doin, 1922.) 18 francs net.

*Le Principe de la relativité et la théorie d'Einstein.* Par Dr. Leon Bloch. (Bibliothèque des Annales des Postes, Télégraphes et Téléphones.) Pp. iii + 42. (Paris: Gauthier-Villars et Cie, 1922.) 3.50 francs.

*The Romanes Lecture, 1922. The Theory of Relativity and its Influence on Scientific Thought.* Delivered in the Sheldonian Theatre, May 24, 1922. By Prof. A. S. Eddington. Pp. 32. (Oxford: Clarendon Press, 1922.) 2s. net.

ANOTHER collection of books and pamphlets reminds us of the hold which the theory of relativity has on the public imagination.

The Abbé Moreux gives his book the title "Pour comprendre Einstein," though he seems to consider that the effort to understand him is so much waste of time, for in his view the theory is both superfluous and misleading. Dr. Strasser, an anatomist with an amateur's interest in physics, gives us a critical discussion of the theory, but it is manifest that he has not come near to understanding it. Prof. Rougier, a philosopher who has read all about the new physics, sets out to tell us something of the influence of the theory upon philosophy, but leaves us with the impression of a shallow and ill-digested understanding of the develop-

ment of physical science and tells us little about philosophy. Prof. du Pasquier and Dr. L. Bloch are less ambitious in their aims; they are content to be expositors and not critics. The results are correspondingly more successful and will probably be very useful to the French reader.

But among the books before us, the English reader naturally turns to Prof. Eddington's Romanes Lecture to hear the latest thoughts of one who has done more than any man living to establish and to popularise the general theory of relativity.

The lecturer impresses it upon his audience that it is stale news that the events around us form a world of four dimensions. There is, however, something that is new. It used to be customary for us to think of this four-dimensional world as having a definite set of sections, any one of which represented the state of the universe at a particular moment of absolute time, the whole being thus stratified in recognisable layers. But now this stratification has disappeared, there are no absolute time sections; it is only the individual observer who, to meet his own convenience, dissects the whole into "slices," labelling each with the mark of an instant of his own consciousness. With a wealth of illustration and with language both grave and gay Prof. Eddington seeks to cure us of our egoistic outlook, and to persuade us to the wider view which finds truth, not in a particular picture of reality seen from one angle, but in a vision which includes and comprehends every possible picture. "It is only in this undissected combination of four dimensions that the experiences of all observers meet." On this we need scarcely dwell here, save to remind ourselves that the fault from which he would save us is one to which men in all ages have been prone, and not the least sinners have been those whose profession was the pursuit of exact truth. Yet we cannot help feeling that at times the preacher goes too far and so damages his case. To quote an illustration from the lecture. We allow an apple to fall. The moment the apple is released the earth begins to rush up to meet it. This is "the apple's view of things." "It is simpler than Newton's. We should regard it as on an equal footing with that of a terrestrial observer." This is very like asking an engine-driver to admit that it is quite natural to consider that when he admits the steam to the cylinder he sets not the engine but the whole universe in motion.

This is trifling however. Let us return to our destratified world of four dimensions. If we have been able to achieve this vision or to conceive of its possibility, we have grasped the essence of the doctrine of relativity, and we have come near to a superhuman view of history. The world is laid out before us as a changeless whole. Time and space are no more.

All is static. Dynamics has been resolved away. We can no longer ask about causes; that is to go back to the human point of view. We can simply gaze upon the scene and seek to catch some of its salient features.

So far as our present conceptions go, one of the most striking things about the picture will be that it is fibrous. The tangible part of it will be a great number of threads, one-dimensionality. These represent electrons. Mere mortals think of them as moving points, but with our new vision we see them as continuous threads. These are chiefly present in bundles, twisted together into ropes; what are these? They are the material bodies of the mortals. One is an atom. Another, much more complex, is a man; another is a chair. The former in one part is gathering more threads to itself; in another part the threads unravel and dissipate. Such is life. In one part the chair-rope and the man-rope are in contact; the man is sitting on the chair. But of the behaviour of man as mortal the picture tells us little. We must become mortal and see only sections of the picture before we can see him as a living being with an unfolding consciousness. If the poet and the mystic do indeed aspire to free themselves from the fetters of time and space, as we read in the concluding passage of the lecture, we fear that they will find but little left either of poetry or of mystery in the world after which they yearn.

But, leaving the poet aside, and returning to the physicist, what is left for him in the great synthesis of all science into the one map of all events? What becomes of his vocation of measurement? As Prof. Eddington emphasises again and again, he too, with all his experiments, is in the picture. His rules, scales, clocks, photographic plates are all there; their whole history is depicted. All his experiments of measurement are represented by the passage through the picture of the threads that represent the marks on the scales, meeting and intersecting the threads that represent other particles of matter. The four-dimensional picture itself is not to be measured. It contains within itself the process of measurement in the ordinary three-dimensional world and all the results are recorded for us to read. We have no four-dimensional scale which we may move about and apply to different parts of the picture for the sake of comparison. We merely stand, look, and try to read what we see.

Perhaps Prof. Eddington does not see the picture quite in this way. Perhaps the "world" for him is a four-dimensional continuum in which our threads are merely lines of singularity. He seems to contemplate as "measurable" the intervals between pairs of points in this continuum which do not correspond to events in the history of any particle or electron in the material universe. But we wish to ask him how these intervals

are in practice to be measured. He says, "When we have mastered the geometry of the world we shall have inevitably learnt the mechanics of it." That is so. A complete description of the world lines of all particles necessarily tells us all about the phenomena of motion.

To master the geometry of the world means to describe its main features by means of a few simple propositions. In Prof. Eddington's view, the process consists in measuring all the intervals between all pairs of neighbouring events, and then in examining whether these intervals will fit together in an Euclidean fashion, or in a particular type of non-Euclidean scheme. If we discover that they will fit in a recognised and manageable mathematical scheme, we have mastered the geometry of the world.

But we ask again how are these intervals to be measured. Since all measurements are contained in the picture, and since for the description of the picture event by event no system of intervals is necessary, the whole of our experimental measurements have nothing at all to do with a scheme of intervals, and any geometrical system whatever may be used for the purpose of attaching intervals. What, then, is it which discriminates between Einstein's system and any other possible one? It is simply this, that if we adopt that system, the facts of the motions of particles or of the propagation of light can be expressed in a very simple form. The path of Mercury, for instance, is a geodesic. Possibly this fact may be further analysed and shown to follow from the configuration of the electron being spherical. But in any case we cannot measure the tube which would represent such an electron in the super-world of four dimensions.

Thus Einstein's law of gravitation, by itself, is not a statement about the world at all. It is only when it is taken in conjunction with some other hypotheses, such as that the path of a particle is a geodesic, that it predicts anything, and becomes capable of experimental test. The world itself cannot be said to be either Euclidean or non-Euclidean, for it does not furnish us with definite values for the intervals between all pairs of events in the continuum. We may say that the world-phenomena are more simply described on the basis of a non-Euclidean system than on a Euclidean system; but it is surely not allowable to go further and say that this is "because the world is not a Euclidean or flat world." Prof. Eddington would perhaps reply that for him the world is nothing more than the measurements that we make of it, and that these measurements do not fit in a Euclidean scheme. But this brings us round again to the same question, what is meant by measurements of the four-dimensional whole? We would ask our lecturer to give us a sequel

to this discourse in which, assuming the four-dimensional presentation, he would state explicitly, either in general terms or by precise illustration, how he would compare the intervals between any two pairs of events.

E. CUNNINGHAM.

### The Marketing of Whole Milk.

*The Marketing of Whole Milk.* By Dr. H. E. Erdman. (The Citizen's Library: Marketing Series.) Pp. xvi + 333. (New York: The Macmillan Company; London: Macmillan and Co., Ltd., 1921.) 21s. net.

THE recent disputes concerning the price of milk have again shown how difficult the problem has become under modern conditions, more especially in the large towns. The farmer is no longer able to take his milk direct to the consumer except in the case of a village or small town, and there has arisen a class of dealers or distributors who occupy the place of the middleman. Some of these distributors are large companies with the command of much capital, and their powerful organisations have led to something very like monopoly. The producers, on the other hand, have also organised themselves, and a struggle between the two parties has recently ended. In the volume under notice, this question as it appears in the United States is very completely analysed, and Prof. Erdman, who is an economist, has dealt with it more fully and critically than has previously been attempted. After discussing the peculiar position occupied by milk as a foodstuff, and the regulations which the public health authorities of all civilised countries have imposed, the author takes marketing and distribution, instances what has been done in the past and states the present position. The part played by the middleman and dealer is made clear, and the rise of collective bargaining is illustrated by the action of the Orange County farmers in their successful fight with the New York dealers in 1883, which may be regarded as the beginning of what has now become the general practice in the large American cities. The strike—or better the boycott—has been the weapon of the producers, and experience has shown that it is two-edged, owing to the difficulty which the farmer has in disposing of his milk—a perishable commodity—except by making it into cheese or butter or, at worst, by feeding it to stock, all of which courses are seldom remunerative. It is made clear that the producers must also submit to regulations governing their combined action, otherwise the results are doomed to failure.

Other matters dealt with are the difficulty of arriving at the cost of milk, owing to the position of the farm, the ability of the farmer, the proximity to market, and

so on, and it is laid down that the method of arriving at a basic price can only be a starting-point in negotiations.

This book, which makes a strong appeal to the general reader, will be of interest to all concerned in the milk trade, whether as producers, distributors, or consumers, and it should lead to what the author regards as the only solution of the difficulty—"a better understanding all round."

### Our Bookshelf.

*Proceedings of the London Mathematical Society.* Second Series. Vol. 20. Pp. liv + 502. (London: F. Hodgson, 1922.) n.p.

THE present volume of the London Mathematical Society's Proceedings is the fifty-fifth issued since the foundation of the society and the twentieth in the present (large octavo) series. Like the preceding volumes issued by the society, it consists mainly of papers which embody original investigations on various mathematical subjects. Many of the papers, of which there are nearly forty, will appeal only to a limited class of reader. In mathematics, even more than in other sciences, the results of new investigations are apt to appear abstruse to the lay mind. The solution of a cubic equation, the Newtonian theory of gravitation, even the elementary applications of the calculus, fundamental and well known as they are now, were not familiar to the world, or even to the general run of university students, for many years after their discovery. By providing facilities for the publication of these specialised researches the London Mathematical Society has earned the deep obligation of the English mathematical world. Practically all the society's income is expended in producing its Proceedings, and, in view of the increased cost of printing, a large membership is essential to provide adequate funds. Inasmuch as every man is a debtor to his profession, every English mathematician should help to further the work of the society by becoming a member.

In the volume under review the articles most likely to appeal to the general reader are the excellent obituary notices of the late Lord Rayleigh and Herr Adolf Hurwitz, written by Profs. Lamb and Young respectively. There is also printed a presidential address on "Some Problems in Wireless Telegraphy" by Prof. Macdonald. Of the more technical papers it would be invidious to single out any one for special mention. The society insists on a high standard of excellence in everything it prints, and the inclusion of a paper in the Proceedings is a sufficient guarantee of quality. We notice that there is an almost entire absence of pure geometry from the present volume. Can it be that research in this subject is no longer encouraged in England?

The method of indexing each individual volume of the Proceedings leaves nothing to be desired. A subject index to the first thirty volumes of the first series was issued many years ago. We suggest that the time is approaching when the Council should consider the desirability of publishing a further subject index to the later volumes.

W. E. H. B.

*A Laboratory Manual for Comparative Vertebrate Anatomy.* By Libbie H. Hyman. Pp. xv+380. (Chicago: University of Chicago Press, 1922.) 2.50 dollars net.

This work is the outcome of a particular course of practical lessons conducted by its author. The disability which such an origin fastens upon a book is well known to every teacher of zoology, and Mr. Hyman's book is no exception to the rule. It suffers from the conditions of its birth—not that these, though American, were insalubrious, but that they were so highly specialised as to limit greatly the adaptability of the offspring. Nevertheless the care that has obviously been taken by the author, and his ability in presentation, should make his book useful even in our small cis-Atlantic schools of zoology, where a somewhat more elastic course of instruction is possible than that provided at Chicago.

Mr. Hyman rebels against the tyranny of the type system, and uses the comparative method of study in his laboratory. His chapters describe in succession the systems of organs of the Vertebrata as exemplified by Elasmobranchs (*Mustelus*, *Acanthias*, *Raja*), Urodeles (*Necturus*), a Chelonian, the pigeon, the cat, and the rabbit. The instructions for dissection are clear and sufficient; and an attempt is made to bridge the gulf which commonly yawns between the principles of the lecture room and the observations of the laboratory, by supplying an accompaniment of morphological comment in the form of introductions and summaries to the chapters. This device and the general nature of the first four chapters disguise—but do not dispose of—the evils of the type system, which are perpetuated in spite of the author's dismemberment of his types and the wide dispersal of their remains throughout the book.

Only one notable omission has been detected: Mr. Hyman's classification of the Chordates—two pages in length—ignores the Dipnoan fishes, nor in the whole of his book do they once appear, though the thesis often plainly demands them.

A pronouncing glossary forms a valuable appendix, though we fear its phonetics will not be acceptable to English ears. H. G. N.

*Studies in the Theory of Human Society.* By Prof. F. H. Giddings. Pp. vii+308. (New York: The Macmillan Co.; London: Macmillan and Co., Ltd., 1922.) 14s. net.

PROF. GIDDINGS points out that in science this century has been a time of rectification rather than of great discoveries. This applies particularly to the fundamental conceptions of sociology. These "Studies," which are always suggestive, frequently provocative, and in more than one instance illuminating; are a contribution to the revision of the theory of human society necessitated by the increased clarity and precision in scientific vision which has come about in the last twenty years. Their somewhat discursive character makes it difficult to give a concise account of the author's achievement in this direction; but, in brief, it may be said to lie in the application of a psychological interpretation to the conclusions of writers such as Darwin, Spencer, Bagehot, and Kidd, to name the more important, thereby accounting for social origins and the stages in the evolution of society in terms of the struggle for existence. Prof. Giddings's theory of human

society is that social phenomena are a product of stimulus reacted to by "pluralistic" behaviour, giving rise to consciousness of kind—the "herd instinct" of other writers—from which are derived discriminating association, the ethical code, co-operation and division of labour, and, in the long run, selection and perpetuation of the adequate—the "fit" of an older terminology.

*The Chemical Examination of Water, Sewage, Foods, and other Substances.* By J. E. Purvis and T. R. Hodgson. (Cambridge Public Health Series.) Second and enlarged edition. Pp. viii+346. (Cambridge: At the University Press, 1922.) 20s. net.

IN this edition the authors have expanded the chapters on water and milk, given more details on the analysis of foods and beverages, and added "an outline of elementary toxicological analysis." A very good feature is the inclusion of plenty of typical analyses. The book will be found very valuable to students preparing for the examination of the Institute of Chemistry, and can be recommended as a useful introductory treatise. Although the quoted results of water analyses are given with the acids and bases combined, there is no indication as to how the necessary calculations are to be made, and some of the sections are so condensed that it is doubtful if they are of value. A great drawback to the utility of the book is its high price.

*Modern Chemical Lecture Diagrams, with Uses and Applications fully described.* By Dr. G. Martin, assisted by J. M. Dickson and Maj. J. W. Christelow. Pp. 88. (London: Sampson Low, Marston and Co., Ltd., n.d.) 3s. 6d. net.

THE purpose of this book is not clear. The illustrations are found in most text-books with adequate descriptions—those supplied in the present work are often too brief to be of any service, as "Fig. 5 shows how these tubes were experimented with by Andrews and Tait." Many of the diagrams represent apparatus far from "modern." The only calorimeters illustrated are those of Favre and Silbermann; chromium is prepared by Fremy's method; sulphuric acid is concentrated in glass retorts, etc. In some cases the descriptions are faulty: Bunsen's eudiometer is ascribed to Cavendish; the Almaden process for the manufacture of mercury is called "Distillation of mercury," etc. As a work of three authors a more modern result might have been expected.

*Forensic Medicine and Toxicology.* By Dr. J. Dixon Mann. Sixth edition, revised throughout. By Dr. W. A. Brend. Pp. xi+573. (London: C. Griffin and Co., Ltd., 1922.) 30s.

THE sixth edition of Dixon Mann's "Forensic Medicine and Toxicology," which ranks among the foremost English text-books on the subject, is the second to be edited by Dr. William Brend. It has undergone a revision which brings it completely up-to-date; a larger page is used than in previous editions, and the number of pages is reduced. The section on insanity has been rewritten on the basis of modern psychiatric views; and that on toxicology gives additional information on poisoning by salvarsan, tetrachlorethane, T.N.T., and the gases of warfare, and on the infections formerly ascribed to ptomaine poisoning.

### Letters to the Editor.

*The Editor does not hold himself responsible for opinions expressed by his correspondents. Neither can he undertake to return, or to correspond with the writers of, rejected manuscripts intended for this or any other part of NATURE. No notice is taken of anonymous communications.]*

#### Relativity and Physical Reality.

In a review by Prof. H. Wildon Carr entitled "The New Way of Thinking Physical Reality," which appeared in NATURE of October 7, p. 471, the writer (speaking of a work by Prof. Léon Brunschvicg) says regarding physical reality: "According to Einstein, we cannot say, speaking absolutely, that there is any picture even for God."

It seems to follow from this that not even the Almighty himself could understand the theory of relativity. If this be so I cannot help thinking that the fault lies with the theory of relativity and not with the Almighty.

The writer then proceeds to say: "The picture is only known as a function of the frame. That is, the things measured are only known through the measurings, and the measurings are bound up with the things they serve to measure."

This seems to imply that measurement is the fundamental thing to be considered in space-time theory, and with this I am not in agreement.

In my book, "A Theory of Time and Space," published in 1914, I showed that the ideas of measurement could be built up from the ideas of *before* and *after*, which were regarded as absolute and not dependent on any particular individual.

In my smaller book, "The Absolute Relations of Time and Space," I gave an abbreviated account of this work and added an appendix showing how the various complicated geometries which are treated of in Einstein's generalised relativity could be obtained by means of a modified measure of interval.

However, most relativists have been too busily engaged in praising Einstein to spare the time to go into my work.

One result of this has been that, by taking the idea of measurement as the fundamental thing, a very large number, if not the majority, of relativists have fallen into the very serious error of asserting that the length of what they call a "world-line" is a minimum between any two points of it. In my "Theory of Time and Space" I showed (p. 360) that this is not correct.

Finding that a number of writers were making this mistake, I wrote a letter which appeared in NATURE (February 5, 1920, p. 599) in which I invited attention to this matter and pointed out that in what I called "inertia lines" the length, so far from being a minimum, was actually a maximum in the mathematical sense; while, in what I called "separation lines" the length was neither a maximum nor a minimum.

In this letter I gave actual numerical examples to illustrate these points. I invited attention to the matter again in my "Absolute Relations of Time and Space" (p. 71), published in 1920.

In spite of these efforts of mine, I again find this blunder cropping up in works published this year. Now it seems to me that it is a very important point since, in ordinary geometry, there is no such thing as a "longest" line joining two points.

The idea would, I think, be apt to cause bewilderment in the mind of a person meeting it for the first time, unless it were properly presented to him.

The idea of a "straight line" which was neither a maximum nor a minimum would, I fancy, cause even greater bewilderment, and he would wish to know how such lines were to be defined.

In Einstein's generalised relativity, the element of interval is taken as a starting-point, although the idea of an interval in the minds of many writers is so obscure that they ascribe a minimum property to it which it does not possess.

Although I have tried so often to impress on relativists that the ordinary method of treating space-time theory is unsatisfactory, I propose to make one more attempt to show that the measurement of intervals is not the simple thing that is so often supposed.

Let us consider the simple time-space theory in which the length of an element  $ds$  of what I call a "separation line" is given by the formula:

$$ds^2 = dx^2 + dy^2 + dz^2 - dt^2.$$

Let O be the origin of co-ordinates and let P be any point on the axis of  $x$ , at a distance  $l$  from O, measured, say, in the positive direction.

Let  $F(x)$  be any arbitrary differentiable function of  $x$  which is continuous and single valued, and which is equal to zero for  $x=0$  and for  $x=l$ .

Now consider the space-time curve the equations of which are:

$$y = t = F(x), \\ z = 0.$$

It is evident that this curve passes through O and P.

But now we have

$$dy = dt, \\ dz = 0, \\ ds^2 = dx^2.$$

and so

Thus we have  $ds = dx$ , and so the length measured along the space-time curve from O to P is equal to the length from O to P measured directly along the axis of  $x$ . That is, it is equal to  $l$ .

Thus a space-time curve the equations of which contain an arbitrary function can have the same length between two points as the direct length measured between those points.

ALFRED A. ROBB.

October 11, 1922.

#### The Miraculous Draught of Fishes—an Explanation.

WE have in the Gospel according to Saint John, in his twenty-first and last chapter, an account of the miraculous draught of fishes in the lake of Galilee for which modern research into the habits of the Galilean fishes offers a perfectly reasonable explanation. The account is as follows:

"Simon Peter saith unto them [certain of the disciples], I go a fishing. They say unto him, We also go with thee. They went forth, and entered into a ship immediately; and that night they caught nothing. But when the morning was now come, Jesus stood on the shore. . . . Then Jesus saith unto them, Children, have ye any meat? They answered him, No. And he said unto them, Cast the net on the right side of the ship, and ye shall find. They cast therefore, and now they were not able to draw it for the multitude of fishes."

Simon Peter then girded his fisherman's garment around him and leaped overboard. But the other disciples brought their boat to shore dragging the net full of fishes with them. Further on we read: "Simon Peter went up, and drew the net to land full of great fishes, an hundred and fifty and three: and for all there were so many, yet was not the net broken."

The explanation of this is to be found in a study of the habits of the fishes living in the lake of Tiberius or

Galilee. These fishes are perch-like in form and affinities, so much so that the average American angler, especially if a small boy, would call them perches. However, ichthyologists to-day place them in a family called Cichlidae, though they were formerly called Chromidae. By one name or another, accounts of them may be found in systematic works on fishes.

The first ichthyologist to study these fishes in their habitat was L. Lortet, who made trips to the Holy Land in 1875 and 1880, and in 1883 published an extensive memoir based on the results gained at first hand. Lortet says<sup>1</sup> (p. 106):

"The fishes of the lake of Tiberius, very good to eat, serve as a pasturage for the myriads of crested grebes (*Podiceps cristatus*) and of pelicans. Frequently the grebes snatch at the eyes of the chromids, and with one stroke of their long sharp beaks lift out as cleverly as would a skilful surgeon the two eyeballs and the intro-orbital partition. These unhappy fish, now blind, of which we have taken numerous examples, have thus the entire face perforated by a bloody canal which cicatrises rapidly. It is only the larger individuals who are thus operated on by the grebes, for, not being able to avail themselves of the entire fish, these voracious birds take the precaution to snatch only the morsel of their choice."

The explanation of this we find on his next page, where we are told that these chromid fishes habitually swim at or near the surface of the water.

Canon H. B. Tristram made collections of fishes in the sea of Galilee in 1864, thus antedating Lortet by eleven years, but his book, "The Survey of Western Palestine. The Fauna and Flora of Palestine," was not published until 1884 by the Palestine Exploration Fund.<sup>2</sup> On page 164 he refers to the Chromidae as found in the lake of Galilee in "amazing multitudes" and continues:

"All these Chromidae are frequently found with their eyes extracted, and their foreheads pierced by the Grebes, which prey on them, but they seem to thrive perfectly well in spite of this mutilation, and to flourish in a state of absolute blindness."

Of *Chromis tiberiadae*, the most abundant form, Canon Tristram<sup>3</sup> writes:

"I have seen them in shoals of over an acre in extent, so closely packed that it seemed impossible for them to move, and with their dorsal fins above the water, giving at a distance the appearance of a tremendous shower pattering on one spot of the surface of the glassy lake. They are taken both in boats and from the shore by nets run deftly round, and enclosing what one may call a solid mass at one swoop, and very often the net breaks."

Dr. E. W. G. Masterman,<sup>4</sup> in chapter 2, "The Inland Fisheries of Galilee," of his book, "Studies in Galilee" (Chicago, 1909), thus describes the ordinary activities of the fishermen of the lake of Tiberius: ". . . their movements being directed by a man stationed on a point of the shore high above the water, who from his vantage ground is able to detect the presence of a shoal of *musht* (Chromids)." The fishermen, proceeding to the point indicated by the look-out,

<sup>1</sup> Lortet, L. "Poissons et reptiles du lac Tiberiade, etc.," in his "Etudes Zoologiques sur la fauna du lac Tiberiade, etc." Archives Museum Histoire Naturelle de Lyon, 1883, vol. 3.

<sup>2</sup> The Palestine Exploration Fund is interdenominational in its organization and sources of income. It has H. M. King George V. for its patron, and is supported by voluntary subscriptions. Its purpose is the thorough study of the archaeology, geology, geography, history, natural history, etc., of Palestine.

<sup>3</sup> Dr. H. B. Tristram, Canon of Durham Cathedral, because of ill-health (lung trouble) lived in Algeria during the winters of 1855-1857. He went to Palestine in 1860 and remained for some years studying the fauna and flora, the resulting data being incorporated in his 435-page quarto volume, the standard work on the natural history of the Holy Land. In 1879 he was nominated for but declined the Anglican Bishopric of Jerusalem. He was the author of seven books on Palestine.

<sup>4</sup> Dr. E. W. G. Masterman is, and has been for a number of years, honorary general secretary of the Palestine Exploration Fund in Palestine.

quickly run a net around the school. However, he tells us that the bottom everywhere is obstructed with large stones, and that the fishermen have continually to dive to free the net. This is possibly if not probably the explanation of Peter's leaping overboard.

From the excerpts given, it is plain as to the purport of the proffered explanation, if in the East, where customs change but slowly, we may interpret the past in terms of the present. Fish which go in schools at the surface of the water; fishermen who have not yet struck a school; Jesus on high ground looks over the lake, sees a school and points it out to the fishermen; they cast their nets in the direction indicated and draw them in full to the breaking point.

E. W. GUDGER.

American Museum of Natural History,  
New York City, Sept. 27.

### Arabic Chemistry.

I. MAY I be allowed to direct the attention of those interested in the history of chemistry to an important paper by Prof. Eilhard Wiedemann of Erlangen? It is entitled "Zur Alchemie bei den Arabern" and is published in Heft V. of the "Abhandlungen zur Geschichte der Naturwissenschaften und der Medizin," Erlangen, 1922. It contains a translation of the passage concerning alchemy in the "Kashfu'l-Zunün" of Hajji Khalifa, with many biographical details of the chemists mentioned. Several of these details have been provided by Prof. Brockelmann, the author of the monumental "Geschichte der arabischen Litteratur," and are entirely new. There is also a list of the most important works (with a few extracts) of the famous Aidamir al-Jildaki († 1361).

It is perhaps ungenerous to offer any criticism of so useful a contribution to chemical history, but I feel that Prof. Wiedemann's explanation of 'ilm al-mizān (science of the balance) as *Beziehung und Abwägung des richtigen Masses* should not be allowed to go unchallenged. As I have pointed out in the current number of *Science Progress* (October 1922), the term "Science of the Balance" as applied to alchemy refers to the proper adjustment of the *qualities* of a substance, that is, its hotness and dryness, etc., and is not used in a quantitative sense, even by Al-Jildaki, and certainly not by Jābir ibn Ḥaiyān, who, I believe, originated it.

A work by Al-Jildaki which seems to have escaped the notice of Prof. Wiedemann is "Zahrul-Kimām," a commentary on an alchemical poem ("Qaṣīdatu'l-Nūniyya") of Abū'l-Asbā' Abdu'l-Azīz ibn Tammām al-Iraqī (wrongly named, Abū Casba by Berthelot, "La Chimie au Moyen Age," tome iii, p. 4). Ibn Tammām al-Iraqī was a contemporary of Al-Jildaki, who thought very highly of him.

ii. Berthelot (*op. cit.* p. 5) says, "Plusieurs des auteurs alchimiques arabes ont été traduits en latin, aux XII<sup>e</sup> et XIII<sup>e</sup> siècles, et ces traductions existent en manuscrit dans les grandes bibliothèques d'Europe. Un certain nombre d'entre elles ont même été imprimées . . . dans les collections intitulées *Theatrum chemicum*, *Bibliotheca chemica* (etc.). . . . A côté d'œuvres authentiques, je veux dire réellement traduites ou imitées de l'arabe, telles que la *Turba*, les écrits attribués à Rosinus, Morienus, Avicenne, etc., il en existe d'autres, fabriquées de toutes pièces en Occident, comme les prétendues œuvres des faussaires latins qui ont pris le nom de Gēber."

The first part of Berthelot's statement is undoubtedly correct, although Berthelot himself was not able to discover the Arabic texts of any of the works he mentions as of probable Arabic origin.

Perhaps, therefore, the following facts will be of interest.

(a) In a work entitled "Knowledge Acquired concerning the Production of Gold," an edition of the text of which, with a translation, I have in the press (Geuthner, Paris), the author, Abū'l-Qāsim Muḥammad ibn Aḥmad al-Īrāqī, quotes several passages which he attributes to Marianus (Morienus, *supra*), the teacher of Khālid ibn Yazid. Many of these passages occur in the Latin "Liber de Compositione Alchemiae," ascribed to Morienus, which is to be found on pp. 509-519 of vol. i. of Mangeta's "Bibliotheca Chemica Curiosa" (1702).

(b) On p. 217 of vol. ii. of the latter treatise is a work entitled "Epistola Solis ad Lunam crescentem," which begins, "In tenuitate enim nimia dabo tibi de pulchritudine mea lumen." This work is strongly Arabic in atmosphere, and is apparently a translation of the "Risālatu'l-shams ila al-hilāl" ("Letter of the Sun to the New Moon") written by Abū 'Abdullah Muḥammad ibn Umāil at-Tamimi, who lived in the second half of the third century after the Flight (ca. A.D. 900). There is a manuscript of this work, with a commentary by Al-Jildakī, in the British Museum (*Add.* 23,418, xvi.). The Latin line quoted above is an exact translation of the first line of the Arabic poem; I have not yet seen the MS., so that I cannot say whether the agreement between the "Epistola" and the "Risāla" holds throughout.

The second part of Berthelot's statement, namely, that in which he expresses his opinion that Geber's works are forgeries, opens a question too wide for discussion here. I would point out, however, that Berthelot examined less than a dozen of the Arabic works of Jābir ibn Ḥayyān, and as the latter is said to have written more than 500 books Berthelot was perhaps a little premature. Jābir, in his "Book of Properties" (a manuscript of which is preserved in the British Museum), refers to another book of his called "The Summary," which may possibly be the "Summa" of Geber. There is, moreover, in Mangeta (vol. i. p. 562) a work entitled "Testamentum Gebri"; now a commentator of Jābir's "Book of Mercy" refers to the same author's "Kitāb waḥyīna maūthīh," or "The Book of his Last Will and Testament."

Evidence of this and other sorts is gradually accumulating, and it would not surprise me to find that Geber and Abū Mūsā Jābir ibn Ḥayyān were, as for so many centuries they were held to be, one and the same. E. J. HOLMYARD.

Clifton College, October 9.

### On the Occurrence of the Archannelids, *Saccocirrus* and *Protodrilus*, on the South and West Coasts of England.

IN NATURE (vol. 91, pp. 85 and 348) the present writer recorded in 1913 the occurrence—for the first time in England—of abundance of *Protodrilus* in many situations, and a few *Saccocirrus* in one situation near Plymouth, and it was shown that both these forms have the curious preference for situations near high-water mark where fresh water trickles through or over the foreshore at low water, but covered by sea water at high tide (*l.c.* 348). Since 1913 the writer has searched for and found *Protodrilus* in similar situations and in a large number of places between Salcombe and Falmouth, and this year was successful in taking the same animal at two places on the west coast of England, namely, on September 7, near high-water mark where the Wanson (so-called) river runs into the sea at the south end of Widemouth

Bay near Bude. (See Ord. Survey Map, 1 in. to mile, river Torridge, Sheet 127, 1H, 47-53), and on September 22 in a similar situation on a beach—formerly well known for shells—at Woolacombe (see O.S. Map, 1 in. to mile, Barnstaple, Sheet 119, 4C, 16-02).

In 1917 and on various occasions since, the writer has also taken large numbers of *Saccocirrus* (*e.g.*, 80 from a hole in the gravel about 1 ft. by 1 ft. deep in half an hour) on a beach at Portwrinkle in Whitsand Bay (see Ord. Sur. Map, 1 in. to mile, Plymouth, Sheet 148, 5F, 83-15) in a position exactly similar to that described formerly (*l.c.* p. 348). This year a few individuals were also taken in the gravel on the above-mentioned shell-beach at Woolacombe. *Protodrilus* and *Saccocirrus* therefore probably occur in all suitable situations in the south-west of England, and may no doubt be recorded—after search in suitable places—from a much more extended area in the British Isles. The specimens of each genus from all localities belong respectively to one species, so far as can be gathered from external characters, namely *Protodrilus flavocapitatus*, and an apparently new and as yet undescribed species of *Saccocirrus*. It is hoped that the characteristic restless side-to-side movement of the head and anterior region of *Saccocirrus* may shortly be portrayed by cinematograph.

Living in about the same situation as *Protodrilus* and *Saccocirrus* is almost always found the planarian *Gunda ulvae*. This planarian is large and easily found under stones in pools, and therefore serves as a guide in the search for the archannelids. The apparent positive geotropism of *Gunda*, which is probably true, is an interesting phenomenon and not well known; if a number of the planarians be taken on a flat stone, they can be made to change direction a large number of times by holding the stone vertically towards the light and turning it repeatedly through an angle of 180°.

The occurrence of the above-mentioned animals only in the peculiar habitat where the water undergoes violent fluctuations in salinity suggests the presence of an undetected special food supply.

J. H. ORTON.

Marine Biological Laboratory,  
The Hoe, Plymouth,  
October 10.

### Origin of the Name of the Genus *Masaris*.

IN Ed. André, "Species des Hyménoptères d'Europe et d'Algérie," vol. ii. p. 829, it is stated that the derivation of the name "*Masaris*" is unknown. The first species described under this genus is *M. vespiformis* F., from Egypt; it also occurs in Algeria.

May I suggest that the origin of the name is the Arabic name for Egypt, "*Masr*" (also used colloquially for its capital, Cairo). As a common noun "*masr*" means "a fortified place," and its plural is "*amsar*"; the word is connected with the Hebrew word rendered "*Mizraim*" in Genesis. It has long seemed to me that this derivation is at least probable, and I should be glad to know if any other has been suggested. E. W. ADAIR.

Turf Club, Cairo, September 26.

FABRICIUS, 1793, "Ent. Syst." ii. p. 283, in founding the genus *Masaris*, did not indicate any derivation for the name, and L. Agassiz, 1845, "Nomencl. Zool. (Hymenoptera)," masks his inability to give a derivation by the suggestion that *Masaris* is a proper name. F. A. B.



## American Research on Acoustics.

By ALAN E. MUNBY.

THE Wallace Sabine laboratory of acoustics, a photograph of which is here reproduced (Fig. 1) is situated at Geneva, Illinois. It is a three-story building of brick and concrete specially erected for its purpose and forms a unique design, consisting of two structures under one roof, an inner room or sound chamber completely insulated from an outer shell. Figs. 2 and 3 show a plan and section of the building, the main feature of which is the sound chamber 27 ft. by 19 ft. and 19 ft., 10 ins. high. Here the original intensity of the sound is measured. The walls of this chamber are of 18-inch brick coated with cement outside and with wood fibre plaster inside, and the room as shown in the section has a separate concrete foundation. From this room half-way up



FIG. 1.—Riverbank laboratories, Geneva, Illinois.

its walls three small testing chambers are provided furnished with heavy steel doors to exclude sound completely. Materials to be tested are placed across these chambers, when the doors are opened to admit sound from an organ in the sound chamber. The organ is a complete 73 pipe instrument giving all the tones of the musical scale from C 64 to C 4096. It is operated electrically by the observer, who notes the time before a sound becomes inaudible in the test chamber. To ensure equality of sound distribution in the sound chamber a large steel reflector mounted on a central shaft is made to revolve in the room on a vertical axis. The main work, up to the late Prof. Sabine's death, has been connected with the calibration of the sound chamber and its instruments. This laborious undertaking completed, the activities of the laboratory should rapidly command a wider interest.

The present director of the laboratory, Prof. Paul E. Sabine, has recently published the results of an investigation on the nature and reduction of noises as occurring in business offices. Scarcely anything has been done

in the way of investigation on the subject of noise, though the topic is obviously of wide interest. Prof. Sabine begins by pointing out that the sound-absorbing qualities of any material vary widely with pitch, and instead of attempting to apply data obtained for musical sounds, he wisely deals with the matter *de novo*, taking the actual sources of sound, such as the click of a typewriter, as the source for experimental purposes. A distinction is drawn between sounds in the open air and those in which reflection takes place, as in a room, from the point of view of the effect of the noise of one operator upon another. All but two or three per cent. of sound waves falling on a hard plaster wall are reflected, and in an experiment cited there were found to be 500 reflections before a given sound reached final decay. It would seem, therefore, that as much absorption as possible by walls and ceilings should be aimed at to prevent these reflections.

An important point brought out by these investigations is that the absorption efficiency of a given material for both musical sound and noise is greater when the material is employed in small units. In discussing practical measures Prof. Sabine alludes to linings of felt for walls, covered with some fabric, to light porous tiles and plaster, citing a plaster recently developed which is a much better absorber than ordinary plaster. He even makes a distinction between painted and unpainted walls, the general tendency of paints being to fill up a porous surface and thus decrease sound absorption, and numerical data are given showing the relative value of various surfaces in absorbing the sound of a typewriter. In these experiments the difference of power of absorption of a given material for various sounds, though existing, was found to be small.

Prof. Sabine has made a separate and special investigation of the absorption of sound by rigid walls and finds that the refraction effect on the passage of the sound into the new medium is of only trifling importance. His experiments have recently been further extended to tests upon artificial aids to hearing. He classifies the types of instruments commonly used and describes investigations to measure the difference of times during which residual sound may be heard with and without a particular instrument as a measure of the increase in loudness produced by that instrument. His results are illustrated graphically. It was observed that the highest tones in every case were less loud with instruments than without, suggesting that the short wave lengths enter the small cavity of the external ear better than do the air columns of instruments. With certain instruments also the lowest tone (frequency 128) was less well heard than without their aid. Prof. Sabine does not consider the prospects of improvements in alleviating extreme deafness to be good, but points the way by reference to the amplification of telephone currents by the thermionic tube, and he suggests a joint attack on the problem by physicists and physiologists.

Another series of experiments on sound-proof parti-

tions has recently been conducted by Mr. F. R. Watson, also of Illinois University, which are described in Bulletin No. 127 of the University. The results

Hence the problem of assessing sound transmission is a very complex one. The author of the bulletin cited directs attention to the very detrimental effect as regards sound insulation of even small apertures caused by ill-fitting doors or by ventilators; he also makes a distinction between sounds due to air waves striking a separating medium and vibrations such as those caused by machinery, the former best resisted by heavy and rigid walling, the latter by arranging for absorption of the vibrations by beds of sand or like loose material.

From a useful résumé of previous experiments on sound transmission, the conclusion is drawn that rigidity is a deciding factor in sound prevention, and some experiments recently conducted by Prof. P. E. Sabine are cited which showed that a plate of glass three-sixteenths of an inch thick transmitted less sound than two glass plates with a sheet of celluloid sealed between them of the same total thickness. A series of tests made at the Music Building, Chicago, in 1895, is quoted, which tends to show that an air space between materials forming the two sides of a partition is of much less value for sound prevention than is commonly supposed, and that benefits which accrue from such space are almost wholly negated by the inevitable connexion at intervals for structural reasons between the two sides.

In Mr. Watson's experiments use was made of the Rayleigh disc resonator, which admits of much more accurate and comparable results than are possible by aural comparisons adopted by many earlier experi-

have led to conclusions somewhat at variance with generally accepted ideas.

Sound, on striking an object, is reflected, absorbed, or transmitted, and usually all three results occur. In any particular case a definite amount of energy has to be got rid of in these ways, and for sound-proofing one may aim chiefly at reflection or absorption. When sound waves in one medium encounter another medium having a different density, the progression of the waves is disturbed, a certain amount of reflection takes place, some of the energy is absorbed, that is, converted into heat, while the amount transmitted through the medium will depend on its thickness and properties, such as porosity and rigidity.

In practice the materials used to separate rooms or buildings are usually of a complex character, and their rigidity will depend not only on their nature and thickness, but on the area of the separating wall.

disc resonator, which admits of much more accurate and comparable results than are possible by aural comparisons adopted by many earlier experi-

ments. A very large number of materials were tested, and these were in all cases of satisfactory area—

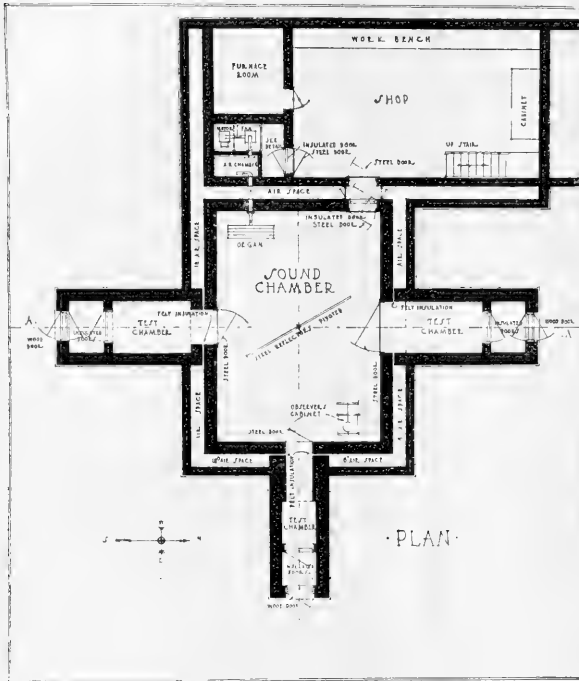

FIG. 1.—Plan of Acoustic Research Building.

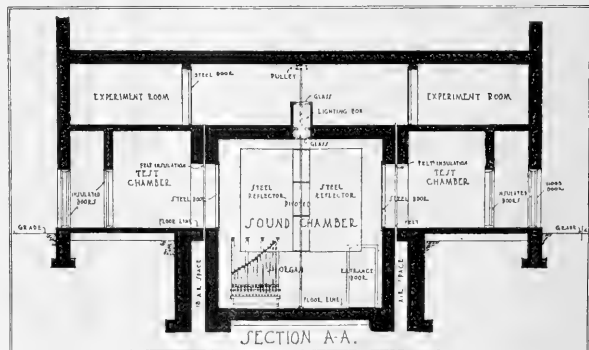

FIG. 2.—Section A-A of Acoustic Research Building.

at least 3 ft. by 5 ft. An adjustable organ pipe blown at constant pressure formed the source of sound placed at the focus of a 5 ft. parabolic reflector facing the partition to be tested in the manner shown in

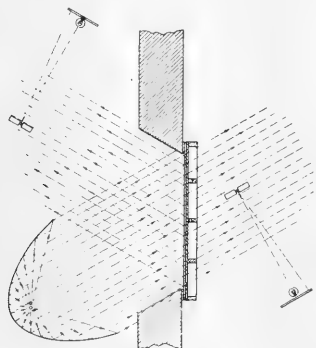

FIG. 4.—Diagram of apparatus for testing transmission and reflection of sound.

Fig. 4, and a disc resonator was placed on either side of the partition to measure the transmitted and reflected sound. Fig. 5 shows a photograph of the apparatus in use, and the observer's box provided to prevent disturbance due to his presence. The general

and it was found that if the transmission through a 2-inch metal lath and plaster partition has an intensity represented by 0.93, a 2-inch well-fitted solid wood door with three-sixteenths of an inch clearance from the floor increased this to 7.3 and with half an inch clearance to 11.7, showing the importance of even very small apertures. As regards composite partitions, the author's conclusions are that the small gain in internal reflection at surfaces of different density is usually more than counterbalanced by the loss in total rigidity, and thus in reflecting power of the initial surface of contact. In practice, of course, too much reflection may be detrimental to the uses of the room in which the sound is generated, and as is pointed out, absorption must be the ultimate aim for the destruction of sound, which means its conversion into heat.

Sound-proofing is of special interest in the modern type of business building, where, in order to economise space and admit of adaptability for changes of tenancy, the structural brick wall has been so largely replaced by the thin partition, and experiments of the type described should be of great value to architects who are responsible for specifying materials and construction. The present writer's experience is that a wall composed of Fletton bricks, which are very dense, is less effective in stopping sound than one composed of stock bricks, which are more porous and less regular.

It would be unwise to generalise too much from the experiments described; with floors, for example, the

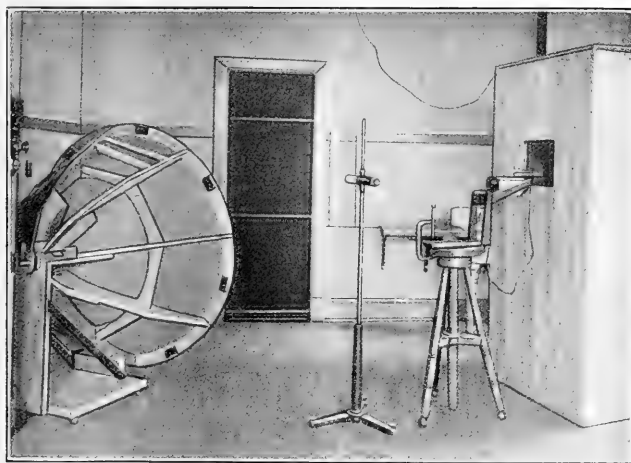

FIG. 5.—General view of apparatus.

results of the tests confirm the views of earlier experimenters cited. Porosity results in absorption but a good deal of transmission, while rigidity results in large reflection; the reflection from hair felt, for example, being 6, while that from Sackett board of the same thickness is 42.7.

The effect of openings such as doors were also tested,

direct contact produces conditions different from those of a sound wave in air, and through a solid concrete floor every footfall may well be heard in the room below. Much further work on this subject is needed, and it is to be hoped that investigation in this country will supplement and extend what is being done elsewhere.

The Galactic System.<sup>1</sup>

By Dr. HARLOW SHAPLEY.

## II.

IN the first part of this article the main characteristics of the globular and open clusters were discussed, and it was shown how the determination of their distances led to the proposal of extremely great dimensions for the galactic system. A theory of the origin and structure of the Galaxy also seems to be indicated by the observations.

## OBJECTIONS TO PROPOSED SCALE OF THE GALAXY.

Although the new values of galactic dimensions have been widely accepted by astronomers, at least qualitatively, they have been openly challenged by some. Without questioning my values (which may indeed have been unknown to him), Prof. Charlier published a few years ago provisional cluster distances that are of a wholly different order of magnitude from those I derive.<sup>8</sup> He had, in effect, affiliated the globular clusters with the local system of B stars. I believe he has now accepted the larger values of the distances.<sup>9</sup>

An extensive critical examination of my methods and results has been made by Prof. Curtis. His discussion and my reply have been published together in Bulletin No. 11 of the National Research Council.

Dr. Schouten has attempted to derive the distances of clusters by assuming that the frequency of absolute magnitude (the luminosity-curve) is the same in globular clusters and in the neighbourhood of the sun.<sup>10</sup> The method is questionable for several reasons: (1) All spectral types are lumped together by Schouten regardless of our present knowledge of the peculiar relation of type and luminosity in the globular clusters. (2) The giant-dwarf phenomenon is essentially ignored in the method. (3) The observed luminosity-curves in globular clusters do not conform with the law assumed.<sup>11</sup> (4) It is certainly improbable that the stage of evolution in any given cluster is closely comparable with the average of the many stages represented by the heterogeneous mixture around the sun. (5) As applied, the luminosity-curve method involves dangerous extrapolation, for we know the frequency of magnitudes for only the very brightest stars in clusters.<sup>12</sup>

Using the necessarily fragmentary luminosity-curves for a few clusters, Schouten finds distances averaging about one-eighth the values I have computed.

Recently, Kapteyn and van Rhijn published a valuable paper on the proper motions of Cepheid variable stars of the short-period sub-type.<sup>13</sup> It is generally accepted that Cepheid variables of long period are giant stars; and from the simultaneous occurrence of the long-period and short-period Cepheids in globular clusters,<sup>14</sup> I have assumed of course that the short-period Cepheids, which occur most frequently in clusters and serve in one of the methods of estimating the distances, are also giant stars. Kapteyn and van Rhijn, on the other hand, have computed, from the large values of the proper motion, small

distances for the cluster-type variables, and therefore low luminosities. They conclude that Cepheid variables of this sub-type may be dwarfs, both near the sun and in clusters; and, by assuming that the long-period Cepheid variables in clusters are abnormalities and the short-period Cepheids are normal, they assert that the clusters may be at less than one-seventh the distances I place them. But Kapteyn and van Rhijn appear to have overlooked the decisive factor that the known radial velocities of these short-period Cepheids are remarkably high<sup>15</sup> (much too high, apparently, for the application of the method they use;<sup>16</sup> and therefore that the large proper motions they deduce and the wide distribution in galactic latitude are almost certainly the result of exceptionally high velocities in space, rather than an indication of nearness and low luminosity. Similarly, the long-period variables of spectral type M are giants at maximum, are widely distributed in galactic latitude, and have high space velocities.

As Dr. Crommelin has hinted recently in the *Observatory*,<sup>17</sup> a sufficient answer to those who would reduce the distance of clusters to one-fifth or one-tenth the values proposed, is that apparently they do not consider fully the dire consequences of such reduction on a vast body of other astronomical data that is now generally accepted. If the distances I give are not greatly reduced or increased these troubles do not arise; all that we know of the colours, spectra, magnitudes, and motions in the clusters, and of the clusters, then fits in well with our general stock of astronomical fact and theory.

Before we knew much about the character of stars in clusters we were not restricted by observation or theory from placing the clusters at whatever distances we liked. But now, if we alter the present distances by the amount Curtis, Schouten, and Kapteyn and van Rhijn suggest, we immediately set up peculiarities and discordances in great numbers. For example, among other difficulties evoked by such changes, we would seriously question the general applicability of the spectroscopic method of determining luminosities and distances;<sup>18</sup> we would introduce confusion into Russell's and Eddington's theories which now so happily conform with physical laws and observational results, in clusters as well as outside; we would overthrow the period-luminosity law of Cepheid variation. Sooner or later it may be necessary to divide or multiply by 1.5 (Dr. Crommelin suggests 2) the distances I have computed for the clusters; any larger factor will entail alterations elsewhere that now appear improbably large.

It seems to me that a better line of attack on the proposed scale of the Galaxy would be to question the apparent magnitudes rather than the absolute luminosities. The latter, as we have seen, are supported by too much evidence of a varied nature to yield easily. Moreover the values of the absolute luminosities for the stars in clusters come within the range of our usual experience, whereas the apparent magnitudes (and distances) of cluster stars are quite different from those of stars we ordinarily treat.

<sup>1</sup> Continued from p. 547.

Since the computed distances depend equally on absolute and apparent magnitudes, they could be considerably changed, if the apparent magnitudes are widely wrong, without disturbing present ideas about stellar luminosity. The fundamental work on magnitude standards at Mount Wilson, Harvard, Greenwich, and elsewhere supply, however, a basis of unquestioned value for the cluster work. The apparent magnitudes I have observed in clusters cannot, I believe, be far wrong; <sup>19</sup> but has the light of these distant stars been reduced in transit so that the apparent magnitudes as observed are not a true index of distance? This question should be kept in mind, but the following points seem to show that the observed apparent magnitudes do not differ seriously from true apparent values because of a hypothecated diminution of light during its passage through space:

(1) The absence of measurable differential light scattering in space, which would appear as a dependence of star-colour on distance.

(2) The apparent restriction of known obstructing matter to regions near the planes of the local cloud and the Galaxy; <sup>20</sup> the globular clusters we study are practically all outside these regions.

(3) The diameter-magnitude correlation for globular clusters, which shows, almost without exception, that the globular clusters with large angular diameters are bright, and that the faint globular clusters are of small angular diameter. <sup>21</sup>

(4) The absence of observable proper motion for clusters, notwithstanding large space velocities.

#### INCIDENTAL RESULTS

In the course of the investigation on the scale of the galactic system a number of incidental contributions of general scientific interest have been made.

I. The great distances of globular clusters provide a much more sensitive test of the degree of selective scattering of light in space than was formerly available from the studies of the colour of nearby stars. Results from many clusters, including the most remote, agree in showing no certainly measurable effect of distance on colour. We conclude that much less than one per cent. of the starlight is scattered while travelling for one thousand years through space. <sup>22</sup> This result, which does not hold of course for some restricted nebulous regions, indicates the extreme vacuity of interstellar space.

II. This absence of a measurable effect of distance on colour contributes an additional fact of some interest with regard to the nature of light. It is direct observational evidence that the amplitude of the light-pulses of different wave lengths has suffered no differential alteration while travelling for more than 100,000 years. The age of this incoming stellar radiation, compared with that of the radiation used in laboratory experiments, is uncommonly impressive.

III. In a more definitely quantitative manner we can again use the base line in space and in time afforded by the globular clusters to derive another property of radiation. The times of maxima of several short-period Cepheid variable stars in the globular cluster Messier 5 (distance 12,000 parsecs) have been measured concurrently with blue and yellow light. Within the

errors of observation no difference for the two colours is found in the time of these stellar outbursts. <sup>23</sup> That is, in travelling for 40,000 years, radiation that differs in wave length by 20 per cent. differs in time of arrival at the earth by less than two minutes, if at all. This is equivalent to a difference of less than one millimetre in a distance of 5000 miles. Stated otherwise, blue and yellow light travel with the same velocity with an uncertainty of less than one part in ten thousand million.

IV. In still another way can we make valuable use of the long base line provided by the remote clusters. A considerable analysis of the distribution of spectral types among the giant stars shows no measurable difference for near and distant globular clusters. This strongly suggests of course that the nearest systems are not appreciably more advanced in their evolution; but because of the finite velocity of light and the great differences in distance, they are, in our records, nearly 200,000 years older than the farthest ones. With these globular clusters we can, in effect, examine the process of stellar evolution throughout an interval of 2000 centuries. We find no evidence of change in that interval of time. <sup>24</sup>

Now Eddington has shown that very conspicuous advances in the evolution of a giant star would occur in less than 50,000 years, if gravitation is the main source of radiant energy. <sup>25</sup> We are led to believe, therefore, that gravitational contraction is not the main source of the energy that maintains the radiation of stars; it appears that the energy must come from the atom, and probably is released in the course of the transformation of the chemical elements.

The evidence for a slow stellar evolution is strongly supported, I believe, by the existence of stars, which are still in their giant stage, in the open clusters that move along the galactic plane. Dimensions now assigned the galactic system are so large that a single oscillation of a cluster must require millions of years. In fact, a greater space scale for the Galaxy practically makes necessary a long time scale and a slow stellar development. The extreme slowness with which the periods of Cepheid variables change, as Eddington has pointed out, also demands the new source of energy. <sup>26</sup>

V. In this connexion it may be observed that the question of the dependence of the speed of evolution on mass for a giant star is probably answered observationally by the regularly occurring phenomenon in clusters of increasing blueness with decreasing brightness. The well-known investigations by Eddington and Jeans indicate that high absolute brightness is associated with great mass, but the theory is not definite in regard to the relative rates of evolution for different masses. From the clusters we would conclude that the greater the mass the slower the development. <sup>27</sup>

VI. The most luminous stars in globular clusters, the spectra of which, by the way, appear to have the "c-characteristics" which are associated with extraordinary brightness, are more concentrated to the centre than fainter stars. This condition independently supports the inference that the most luminous are the most massive stars.

VII. The remotest object for which a definite estimate of distance has yet been made is one of these

faint globular clusters, N.G.C. 7006, for which a value of about 65,000 parsecs (more than 200,000 light-years) has been obtained, and checked by three or four different photometric methods. The most recent determination of its distance involved the discovery and study with the 100-inch reflector at Mount Wilson of Cepheid variables of the 10th apparent magnitude—the faintest periodic variable stars on record. It is likely that more remote objects, with distances as yet unmeasured, have been seen or photographed—possibly among the faintest spiral nebulae or among the faint stars in the Milky Way.

VIII. A recent investigation of Cepheid variable stars in the Small Magellanic Cloud has shown that the very faintest variables have periods of less than one day.<sup>28</sup> This result, which permits the direct extension of the period-luminosity law to the short-period type of Cepheid, is further evidence of the high absolute luminosity of the kind of Cepheid variable which is most frequent in globular clusters.

IX. The proposal of a larger scale for the galactic system brings us face to face with the "island universe" theory of spiral nebulae, which, with varying success, has for many years maintained that the spirals are other "universes" of stars—that they are galaxies comparable with our own, and that our Galaxy, seen from a sufficient distance, would appear as a spiral nebula. A theory of "comparable galaxies" immediately becomes very difficult to maintain along with the larger dimensions of the galactic system. In a paper published three years ago I discussed at some length this problem of external galaxies.<sup>29</sup> The conclusion reached at that time, that the nebulae of the spiral family are probably neither galactic in size nor stellar in composition, has been strengthened rather than weakened by subsequent investigations, particularly by van Maanen's remarkable work on the motions in the brighter spirals.<sup>30</sup>

X. Since the brighter spiral nebulae, according to the present view, are probably within the boundaries of our galactic system, it may be that the novæ occurring so frequently in the Andromeda nebula represent the encounter of this enormous, rapidly moving object with galactic stars. The suggestion is in harmony with the Seeliger-Monck hypothesis of the cause of ordinary novæ; andæ, moreover, it is in line with the only hypothesis that has yet been advanced to account for the peculiar irregular variable stars in the diffuse nebulae, such as those in Orion.<sup>31</sup> This interpretation of the variables of the relatively near Orion nebula would certainly be of significance for historical geology, since disturbances of our sun, much less serious in character than those observed for novæ and for the Orion variables, would be of paramount importance in matters pertaining to terrestrial climates and organisms.<sup>32</sup>

XI. Conversely we can use the geological records to show that the radiating equilibrium of the sun probably has been uncommonly stable compared with that of many stars. The investigation at Harvard under Prof. Bailey's direction of the frequency of galactic novæ brought out the remarkable result that at least fifteen novæ, brighter than the tenth magnitude at maximum, have appeared every year during the last three decades.<sup>33</sup> If a frequency of even one-fifth that

amount has been maintained throughout the hundreds of millions of years of approximately constant solar radiation (shown by the geological records), more novæ have occurred than there are known stars. Our sun, however, which has certainly escaped not only disasters of this kind but even much less serious disturbances, apparently moves in an uneventful region of space.

XII. The attractive and somewhat futile speculations on the probability of the occurrence of protoplasmic life and its slow evolution elsewhere in the sidereal system must, of course, take account of the frequency of these calamitous stellar outbursts that we call novæ.

In connexion with this attempt at a partial interpretation of galactic structure it might be well to emphasise the following points.

(1) Many of the fundamental laws and assumptions of physics are involved in this sidereal superstructure, so that developments in thought or observation, which hereafter greatly affect these laws and customary assumptions, may at the same time seriously disturb existing conceptions of the sidereal system.

(2) The complete elucidation of the source of stellar energy may bring with it modifications both in our views of the evolution of stars and in our assumption of the importance of gravitational organisation of stellar bodies.

(3) The question of the obstruction of light in space is not in a satisfactory condition, and the nature of the radiation of the diffuse nebulae is little understood; we have essentially no information concerning the pre-giant stage of stars and its relation to the diffuse nebulae, and the dust and gases in space.

(4) Cepheid variables, though comparable with each other, may possibly be sufficiently different from other stars that we cannot use their speed of evolution as a quantitative measure of the speed of evolution for all stars.

For the present I take little heed of these warnings, and merely record them as examples of underlying uncertainties. They serve to remind us that the conclusions are based not only on favourable observations and theory, but also on the absence (for the time being) of seriously unfavourable data.

#### REFERENCES.

8. *Lund Meddelanden*, Series 2, No. 19.
9. *Bul. Nat. Research Council*, No. 11, p. 174.
10. *Proc. Acad. Sci. Amsterdam*, 20, p. 1208; 21, p. 36.
11. *M. W. Contr.* 155, and 175, p. 11.
12. I first tried out the method six years ago (*M. W. Contr.* 116, p. 81), but abandoned it as wholly unsuited to the brighter stars in globular clusters. The Kapteyn luminosity curves for separate spectral types, however, may be of high value.
13. *Bul. Ast. Inst. Neth.*, No. 8.
14. Kapteyn and van Rhijn state that eight Cepheids of long period are known in two globular clusters. In my paper from which they get their data (*M. W. Contr.* 151) I show that twelve long-period Cepheids occur in the five globular clusters Messier 3, 5, 13, 15, and Omega Centauri. Four of these clusters contain also large numbers of short-period Cepheids only one or two magnitudes fainter than the long-period Cepheids. Unpublished results obtained at Harvard show that long-period Cepheids occur in other globular clusters.
15. *M. W. Contr.* 153, *M. W. An. Rep.* for 1918, and elsewhere.
16. *Russell, Astroph. Jour.* 54, p. 140.
17. *Observatory*, May 1922.
18. *Bul. Nat. Research Council*, No. 11, p. 184, 190.
19. The photovisual magnitudes for Messier 11, however, are probably affected by a serious scale error; the colour indices do not agree with the spectra subsequently determined (*M. W. Contr.* 120 and 225).
20. *M. W. Commun.* 6, p. 6; cf. also Hubble, *M. W. An. Rep.* for 1921, p. 251.
21. *M. W. Contr.* 115, p. 12, 152, p. 10, and 161, p. 13.
22. *M. W. Contr.* 156, p. 5.

23. *Hav. Bul.* 763.24. *M. W. Contr.* 156, p. 5, and 157, p. 14.25. *Zeits. für Physik*, 7, p. 390.26. *Mon. Not. R.A.S.* 79, p. 19.

27. This conclusion may not hold for close double stars, as certain results from eclipsing binaries are not in full agreement; the less dense, dark companion is believed to be, frequently, less massive and also less developed than its primary.

28. *Hav. Bul.* 765; *Proc. Nat. Acad. Sci.* 8, p. 69.29. *Pub. Ast. Soc. Pac.*, October 1919.30. *M. W. Contr.* 213 and 214.31. *M. W. Contr.* 156, p. 12; cf. *Graff, Ast. Nach.* 5133.32. *Jour. of Geol.* 29, p. 502.33. The annual number brighter than the tenth magnitude actually exceeds forty, according to Bailey's data. *Pub. Am. Ast. Soc.* 4, p. 248.

### Current Topics and Events.

IN an article on Lord Inchcape's task in the *Sunday Times* of October 22, a former finance member of the Government of India, Lord Meston, makes an alarming suggestion. Speaking of things "useful, but not essential," he says "many of the research institutes and the like will come under the shears." The illiberal spirit which inspired our domestic wielders of the axe may thus be carried by one of them to India—a country which, more than any other, perhaps, has benefited by the application of science to "useful" purposes. The plant breeders there, alone, have literally added millions to the country's wealth; new wheats and cottons yielding 20 to 30 per cent more than the indigenous varieties have already been successfully introduced. It must not be forgotten that, in India, the prosperity of agriculture is a fundamental element of the solvency of the Government, for there, the State, as owner of the soil, takes one half of the rental value of the land. The sum thus raised approaches a moiety of the whole taxation of the country. It is to be hoped that such a suicidal policy as that indicated by Lord Meston will not be advocated by Lord Inchcape, though as a quondam member of the Geddes Committee he may be inclined to repeat its mistakes.

THE French airman, M. Maneyrolle, won the prize of 1000*l.* offered by the *Daily Mail*, by a wind flight on October 21 lasting three hours and twenty-two minutes. The notable successes registered during the recent French contests, and especially during the German contests, raised the question whether British fliers could rival the feats of their foreign colleagues, and the offer of a prize of 1000*l.* by the *Daily Mail* led to the organisation, at Itford Hill and Firl Beacon on the South Downs, of the first British gliding contests since the war, which commenced on October 16 and continued through the week. Additional prizes were offered by the Royal Aero Club and others. The entry of British machines and pilots was very encouraging, there being some two score British fliers, besides foreign aviators, notably the Dutch airman, M. Fokker. A large number of short flights and some quite long flights were made; yet on the whole the results of the meeting were not of a sensational nature until the last day of the meeting. The general conclusion is that British aviators do not fall behind those of Germany, and that it is possible to find suitable arenas in this country for the practice and display of motorless flight. The most notable achievement of the first day of the contest was a thirty-seven-minute glide by M. Fokker, but this was surpassed by a fine flight executed by Mr. F. P. Raynham. This aviator had already taken a place in the front rank of British pilots in the recent air-

race round England: he added to his laurels by remaining in the air in a motorless machine for one hour and fifty-three minutes, thus putting himself in the same category as the German record-makers, Martens and Hentzen. But on the last day, Saturday, two world-records were nevertheless established. J. R. Olley went up in a Fokker biplane, and remained in the air with a passenger for forty-nine minutes, while M. Maneyrolle, in a tandem monoplane glider, succeeded in remaining in the air for three hours twenty-two minutes, thus winning the *Daily Mail* prize and beating the previous record, that of Hentzen, by twelve minutes. During the last ninety minutes of his flight, M. Maneyrolle was accompanied by a monoplane glider flown by Squadron-Leader A. Gray, and it was night when the two machines landed within 100 yards of the point from which they started. These competitions on the South Downs will serve as an encouragement to motorless flight in this country, and will help in the accumulation of knowledge and experience on one of the most interesting developments in modern aeronautics.

THE height of the ground at Firl Beacon, where the gliding competition referred to in the foregoing paragraph was held, is 718 feet above sea level, and it slopes downwards somewhat to Itford Hill, which is situated about three miles to the westward. The gliding was chiefly from one or other of these positions. The meteorological conditions during the week could not be considered altogether favourable, and there was wide difference in the weather on the several days. At times the winds were too boisterous and unsteady for gliding, while at others the gliding was hampered by winds which were too light or by cloud and mist; the direction of the wind was chiefly from between north and east. On the closing day, Saturday, the surface wind was blowing at the rate of about 20 to 30 miles an hour, and M. Maneyrolle, in his record flight, kept mostly at about 200 feet above ground. The controlling conditions of the weather were similar throughout the week; a region of high barometer was situated to the north of Scotland and a region of low barometer was fairly stationary over the north of Spain. All who took part in the gliding contest, however, would know well what different weather could be experienced with similar controlling conditions.

AT a meeting of manufacturers held on October 18 at the Institution of Electrical Engineers it was unanimously agreed, in view of the approval of the Postmaster-General to the memorandum and articles of association of the British Broadcasting Company having been obtained, to proceed with the registration of the company. The capital of the company,

amounting to 100,000*l.* in 1*l.* shares, has been guaranteed by the British Thomson-Houston Company, General Electric Company, Marconi's Wireless Telegraphy Company, Metropolitan-Vickers Electrical Company, Radio Communication Company, and the Western Electric Company: *bona-fide* British manufacturers alone will be allowed to join the broadcasting company and may take up one or more shares. The guaranteeing companies are immediately responsible for 60,000*l.* of the capital, and the balance of 40,000*l.* is offered for subscription: should applications be received for a number of shares in excess of the balance mentioned, the guaranteeing companies will reduce their holdings with the view of meeting the applications of other manufacturers. Lord Gainford has consented to become the chairman of the board of the broadcasting company, which, in the words of its memorandum, is a public utility service for the broadcasting of news, information, concerts, lectures, educational matter, speeches, weather reports, and theatrical entertainments. Each member of the broadcasting company is required to make a deposit of 50*l.*, returnable to him when he withdraws therefrom; he must also enter into an undertaking neither to sell any apparatus, except batteries, accumulators, and aerial equipment, nor made in this country, nor to make broadcasting apparatus for any person who is not a member of the company. For transmission purposes, every member owning an invention must give the use of the same to the company, *i.e.* all patents are to be pooled, so that the broadcasting company will be free of royalties. The expenses of broadcasting are to be met partly from the fees collected on broadcasting licences, the Postmaster-General having agreed to pay over one half of the 10*s.* to be charged for each licence to the company, and partly by contributions, on a royalty basis, to be made by the members of the broadcasting company; the scale of these contributions ranges from 2*l.* 5*s.* in respect of each three-valve set to 2*d.* in respect of each single valve sold. The date for opening broadcasting services has not yet been definitely fixed.

At a joint meeting of the Royal Geographical Society and the Alpine Club on October 16, General the Hon. G. C. Bruce, Mr. G. L. Mallory, and Mr. G. I. Finch gave accounts of the recent expedition which failed by 1700 ft. to reach the summit of Mount Everest. Mr. Mallory said that in light of the experience gained this year the problem of climbing the mountain must be reviewed afresh. The most important modification must be in respect of porters. On this expedition porters had carried a camp to 25,500 ft. and had shown astonishingly little fatigue. It seemed certain that after a night's rest at 25,000 ft. the porters could carry a camp to 27,000 ft. If this could be done, it would facilitate the task, which would then depend on the endurance of the trained climbers. This would entail a climb of 2000 ft. and the corresponding descent in a day. The effort of climbing the last 2000 ft. should not be considerably greater than that of climbing from 25,000 ft. to 27,000 ft., for the difference in atmospheric pressure is only 0·8 in. between 27,000 ft. and the summit, compared

with a difference of 19·5 in. between sea-level and 27,000 ft. But the fatigue of the previous days' efforts and possibly the ill-effects of sleeping at high altitudes would tell against the climber on the last lap. Mr. Mallory is not inclined to think that with the help of oxygen the feat was impossible. A significant fact was that three climbers at a height of 27,000 ft. felt no special distress. Two other considerations must be borne in mind: the dangers involved in avalanches and in the possible loss of muscular power, and the difficulties due to weather. The latter was most serious. Unless the bad weather of this year was abnormal, the weather factor reduces the likelihood of men reaching the summit of Mount Everest and descending in safety.

It was stated in NATURE for September 16, p. 394, that a committee had been appointed to work out a proposed Federation of American Biological Societies. The constitution proposed by that committee is published in *Science* for September 29. It follows the main lines adumbrated in our previous note. We are glad to observe that, in the opinion of the committee, the Federation should in no way conflict with existing organisations, but should rather strengthen their efforts and should avoid unnecessary duplication of effort and expenditure. It proposes therefore to act in close co-operation with such existing agencies as the American Association for the Advancement of Science and the National Research Council. The kind of work that may be undertaken by such a Federation appears from the fact that the proposed constitution calls for the appointment of a Committee on Bibliography and Publication to act in co-operation with similar committees that may be appointed by the two bodies just mentioned. It may be remembered that the British Association has a committee dealing with the zoological branches of this subject, and that the recent Conference of Corresponding Societies requested the Council of the British Association to inquire into the general question of scientific bibliography.

MR. SPURLEY HEY, Director of Education in the city of Manchester, has been moved by our article on "Children and Museums" (NATURE, September 2, 1922) to send us a report on the lectures for elementary school children in the Museums and Art Galleries of Manchester. We were well aware of the admirable work begun in Manchester as a war measure, but found so successful that it has since been continued and extended. Classes are at present held in six institutions, and it is hoped to include three others. Of the eleven demonstrators engaged, nine are certificated teachers. Every attempt is made to co-ordinate the museum work with the inside work of the schools. There seems to be a larger demand for the science courses than for those at the art galleries, but all the courses are exceedingly popular with the children. The general opinion seems to be that these classes awaken the intellect of the children. It is natural that they should help them in such subjects as geography and science, but it appears that they also improve their drawing, teach them in



a practical way the elements of civics, cultivate their manners, and even give the children an increased pleasure in poetry. Indeed there is scarcely a side of education that is not improved in this way. We are not in the least surprised, and we commend Mr. Spurley Hey's report to all educationists as well as to those museum authorities at whom our previous remarks were aimed.

COMMANDER FRANK WILD, leader of the Shackleton-Rowett Expedition after the death of Sir Ernest Shackleton, and Mr. John Quiller Rowett, who financed the expedition, had the honour of being given an audience by the King on Monday morning. The King expressed his deep regret for the untimely death of Sir Ernest Shackleton, and complimented Commander Wild on the successful work accomplished.

We much regret to announce the death on October 27, in his eighty-second year, of Mr. W. H. Wesley, for forty-seven years assistant secretary of the Royal Astronomical Society.

THE second annual meeting of the Deutsche Gesellschaft für Vererbungswissenschaft was held in Vienna on September 25-27. Though technically a meeting of the German society only, in fact the congress was largely international in character, the visitors including representatives from England, America, Italy, Switzerland, Japan, Holland, and the Scandinavian countries. Prof. R. Wettstein presided, and the opening address was delivered by Prof. E. Baur (Berlin). The principal discussions were opened by Prof. Goldschmidt (Berlin) on "The Mutation Problem," and by Prof. Ruedin (Munich) on "The Inheritance of Mental Defects." Among the papers which were read and briefly discussed were the following: the modification of sex factors in fungi, by H. Kniep; relative sexuality, by H. Hartmann; *experimenta crucis* on the inversion of sex, by R. Goldschmidt; experiments with hermaphrodite frogs, by E. Witschi; linkage in antirrhinum, by E. Baur; the deficiency phenomenon in *Drosophila*, by O. L. Mohr; methods of obtaining different sex-proportions in *Drosophila*, by G. Bonnier; polymery in butterflies, by H. Federley; parthenogenesis, gynandromorphism, and the determination of sex in phasmids, by H. Nachtsheim; Blakeslee's experiments on heredity in *Datura*, by C. B. Davenport; the influence of temperature on the offspring of rats, by H. Prziham; the influence of light on butterflies, by E. Brecher; genetic studies in barley, by E. Schiemann; vegetative segregation in *Lupinus angustifolius*, by H. Roemer; transplantation and relationship, by Fr. Erdmann; the inheritance of Hæmophilia and its importance for our conception of the nature of genes, by H. K. Bauer; and variability and the formation of species, by P. Schlesinger. Demonstrations were arranged in the zoological laboratory of the University and in the Natural History Museum. Visits were made to the Biologische Versuchsanstalt (where Prof. Steinach demonstrated his transplantation experiments in rats and guinea pigs) and to the principal libraries and art galleries in the town. Prof. R.

Hertwig was elected president for the ensuing year, and the society accepted his invitation to meet at Munich in 1923.

AN international exhibition of technical, artistic, and scientific photography, optics and cinematography, with a section for the history of photography, will be held in May and June of next year at Turin, Italy. Information can be obtained from the Comitato dell' Esposizione Fotografica, presso la Cemare di Commerciodi, Torino, Italy.

THE council of the Hancock Museum has appointed Mr. T. Russell Goddard, at present assistant curator at the Sunderland Museum, to the position of curator of the Hancock Museum, Newcastle-upon-Tyne. Mr. Goddard was trained under Mr. Montague Browne, and then worked on the staff of the Leicester Museum under Mr. E. E. Lowe for six years, arranging and classifying the local fauna and flora. Thence he proceeded to engage in biological research work in the laboratory of Dr. C. F. U. Meek, previous to his appointment at Sunderland about two years ago.

WE have received the second quarterly issue for this year of *Process Work and the Printer*, which contains among other interesting items an article on "The History of Printing Types," reprinted from the *Printing Supplement* to the *Manchester Guardian*. It is illustrated with many specimens from Gutenberg's first type (1455) to those of the present day. One of the three inset illustrations is a photogravure in colour, but the original water-colour drawing is of such a character that it is not possible to judge of the quality of the reproduction. The editor states that it marks a notable departure in photogravure printing in that it necessitates the printing of a large edition instead of only a few proofs as has hitherto been the case in colour photogravure.

THE Cantor Lectures delivered recently before the Royal Society of Arts by Prof. Arthur M. Hind, Slade professor of fine art in the University of Oxford, on "Processes of Engraving and Etching," are printed in the Society's Journal for September 22. The lecturer does not treat the subject as a practical engraver, but from the point of view of the historian and critic. He seeks chiefly to discriminate the characteristics and limitations of the various processes, and their peculiar fitness for certain kinds of work. The subject is richly illustrated by reference to a very large number of examples. Prof. Hind concludes by stating that "perhaps the greatest danger to recent etching has been its popularity; the public has preferred a bad etching to a good woodcut or lithograph, leaving these other arts a safer though less prosperous field. It is perhaps on that account that some of the best etchers are those who have exhibited least."

DR. GEORG BERG has written to us with reference to a review of his work on ore deposits published in *NATURE* of August 12, p. 205; to point out that the reviewer has done him an injustice in stating that he restricts the term syngenetic deposits to magmatic segregations. In this correction Dr. Berg is undoubtedly right; he does include among syngenetic deposits such ore beds formed by sedi-

mentation as have undergone no chemical change since their deposition, as well as clastic deposits. Unfortunately, he has dealt with the former type of syngenetic deposits (magmatic segregations) first, has then passed to the study of epigenetic deposits, and then, after some 280 pages out of a total of 400 devoted to epigenetic deposits, he reverts to the last two classes of syngenetic deposits, and this method of dealing with the subject caused the reviewer to overlook the fact that Dr. Berg had commenced by stating that these two last classes (ore beds and clastic deposits) were also syngenetic. This explanation will, we trust, suffice to remove the wrong impression created by the comment to which Dr. Berg refers.

MESSRS. W. HEFFER AND SONS, Ltd., are bringing out "Fundamentals of Bio-Chemistry in Relation to Human Physiology," by T. R. Parsons, which is intended to form an introduction to the study of the chemical processes at work in the body. It is addressed more particularly to medical students reading for examinations in physiology. Another forthcoming book in the same publishers' list is "The Ethnology of the American Indians," by Dr. P. Radin, in which particular stress is laid upon a clear delineation of the civilisations of Mexico and Peru and their influence on the culture of the other parts of America. A useful feature of the volume should be the detailed and critical bibliography it is to contain.

### Our Astronomical Column.

A NEW COMET.—A new comet, 1922 c, was discovered by Dr. Baade at Bergedorf Observatory, Hamburg, on October 19, and observed by Prof. Strömgen at Copenhagen on October 22, 8<sup>h</sup> 15<sup>m</sup> G.M.T., in R.A. 19<sup>h</sup> 52<sup>m</sup> 57<sup>s</sup>.75, N. Decl. 36° 57' 38". He gave the magnitude as 9.0, so the comet should be visible in small telescopes. Assuming uniform motion, the following are the positions for the dates named at 8<sup>h</sup> P.M.:

	R. A.	N. Decl.
Oct. 28.	20 <sup>h</sup> 12 <sup>m</sup> 25 <sup>s</sup>	35° 22'
" 31.	20 12 35	34 33
Nov. 3.	20 19 8	33 44

The comet is in Cygnus, and is due south, 15° from the zenith, at 5<sup>h</sup> 30<sup>m</sup> P.M.

SPECTROSCOPIC PARALLAXES FOR TYPE A.—The spectroscopic method has hitherto been limited to spectral types FGKM. A paper by Messrs. Adams and Joy (Proc. Nat. Acad. Sci., July 1922) gives the details of an investigation as to its extension to type A. It had already been noticed that there was a difference in the general sharpness of the spectral lines in stars of this type, and on examining the stars the distance of which is known either by trigonometrical, hypothetical, or moving-cluster parallaxes, there is found to be a distinct correlation between absolute magnitude and sharpness of lines. Using the letters s, n to denote sharp and nebulous spectra, they give the following values for the absolute magnitudes of different types: A1 s 0.0 n 1.2, A2 s 0.6 n 1.5, A3 s 1.2 n 1.7, A4 s 1.5 n 1.9, A5 s 1.8 n 2.1, A6 s 2.1 n 2.2. At this point the two coalesce. They apply the formulae to the Taurus group and the Praesepe, finding parallaxes of 0".024 and 0".011 respectively. Certain stars had already been classified at Harvard as C-stars. They have very sharp and narrow lines, and the enhanced lines, especially those of strontium at 4077 and 4215, are very intense. There is reason to think that these stars, of which α Cygni is the most prominent example, are super-giants, to which the preceding formulae do not apply. They are very luminous and very remote, but material for assigning parallaxes is at present wanting. The authors note that in all spectral types sharpness of lines is associated with high luminosity. They explain this by the very low density of the giant stars.

A paper by Mr. Evershed in the Mon. Not. R.A.S. for last May noted that there were many broad hazy lines in the spectrum of Sirius; he pointed out that in Sir Norman Lockyer's classification, Sirius is on the

descending side of the temperature curve, and quotes his words that in stars of this class the hydrogen lines are relatively broad. Mr. Evershed is inclined to explain the widening as a Doppler effect due either to rapid rotation or strong convection currents. But, whatever the cause, the facts are in accord with the results of Adams and Joy.

GLOBULAR CLUSTERS IN THE LARGE MAGELLANIC CLOUD.—In Harv. Coll. Observ. Bulletin, No. 775, is announced the discovery that five objects formerly catalogued as nebulae are definitely globular clusters. Their N.G.C. numbers are 1783, 1806, 1831, 1846, 1978. The status of two others, Nos. 1651, 1866, is doubtful. The detection of new globular clusters is interesting, since it was announced a few years ago that probably all objects of this class within our reach had been detected. It also enables a new estimate to be made of the distance of the cloud, using Prof. Shapley's formulae. At present only the simple formula based on apparent diameter has been applied. The diameters of the above five objects are 1'.9, 1'.6, 1'.9, 1'.8, 1'.8. The corresponding distance is 35 kiloparsecs, or 110,000 light-years. This is of the same order as Hertzprung's estimate. It makes the linear diameter of the large cloud 4½ kiloparsecs, so that it is comparable in size with our own star system, leaving the outlying galactic extensions out of account.

VARIABILITY IN THE LIGHT OF IRIS.—Prof. Wendell noted in 1904 that this minor planet was variable in light to the extent of 0.35 mags. in 0.259 days. Mr. Campbell found the same period but a smaller range in 1917. But Miss Harwood at the Maria Mitchell Observatory finds no variation in the present year. The case is like that of Eros, and may arise from irregular shape of the object, the amount of variation depending on the direction of the line of sight; it has been suggested that a further complication might arise from a shift in the axis of rotation in the body of the planet, if it were rotating about an axis other than a principal one. The shape of the asteroids might give a clue in questions of cosmogony, hence such researches are useful. In the case of Eros, when observed for parallax there is the possibility of error if the centres of light and of gravity are non-coincident. Mr. Hinks, indeed, found some evidence of a small oscillation of this kind, but the effect would probably disappear in the mean of many observations.

## Research Items.

**EARTHWORKS IN AMERICA.**—The Peabody Museum of American Archaeology and Ethnology, Harvard University (vol. viii. No. 3), has issued a monograph by Mr. C. C. Willoughby on the Turner group of earthworks in Hamilton County, Ohio, with notes on the skeletal remains by Mr. E. A. Hooton. The book, admirably illustrated by sketches and photographs, gives a full account of these interesting structures. Mr. Willoughby remarks that the builders attained a degree of excellence in art design probably unsurpassed north of Mexico. It is important to note that they show no affinity with the people of the Madisonville site, beyond those which are common to all Indians. Their affinities are rather with the Eastern dolichocephals, although there is present a brachycephalic element such as is often found among the Eastern Indians.

**LONG BARROWS IN THE COTSWOLDS AND WELSH MARCHES.**—Under the title of "Notes on the Archaeological Information incorporated in the Ordnance Survey Maps," Mr. O. G. S. Crawford, Archaeology Officer, Ordnance Survey, has published a useful pamphlet with a map showing the position of the Long Barrows and Stone Circles in the Cotswolds and the Welsh Marches. He remarks that the fact that the Cotswold limestone area is a region of relatively high elevation has led some to suppose that this accounts for the abundance of long barrows in this district. But the factors which influenced prehistoric man in the choice of a settlement were not elevation but vegetation and water supply. Prehistoric man selected these limestone areas when the soil favoured an open growth of vegetation, because many regions of high elevation, such as the Black Mountains, are entirely devoid of long barrows. He chose sites where the streams are more numerous, and in Monmouthshire the position of two out of the three long barrows shows that Neolithic man did not shun the lowlands when they served his purpose. Mr. Crawford's introductory essay is interesting and suggestive, and it may be hoped that archaeologists will soon be in possession of similar maps indicating the position of prehistoric remains in other districts.

**THE PAINTED GLASS OF GLOUCESTER CATHEDRAL.**—In that gem of ecclesiastical architecture, the Lady Chapel of the Abbey, Gloucester, the east window, a work dating from the end of the 15th century, at once attracts attention. But the glass is in such a confused and disordered state that the ordinary spectator is scarce able to distinguish any definite subject, and carries away the impression of a mere mass of richly toned fragments, with here and there a face or a form dimly visible. The scheme of the window was obviously to illustrate miraculous stories about the Virgin, but hitherto little has been done to arrange the fragments in a definite way. In the Transactions of the Bristol and Gloucestershire Archaeological Society for 1921 (vol. xliii.) Mr. G. M'N. Rushforth, working on a catalogue prepared in 1915 by Mr. J. D. Le Couteur, a well-known authority on medieval glass, publishes an exhaustive paper, supplied with good photographs. Many of the figures and incidents have now been satisfactorily identified, and much new light is thrown on an important collection of 15th century painted glass.

**GERMINATION OF INDIAN BARLEY.**—Experiments on the influence of atmospheric conditions on the germination of Indian barley have been carried out by Mr. W. Youngman, Government economic botanist, United Provinces, and the results, which have been published as a memoir of the Indian

Department of Agriculture, are summarised in the *Bulletin of the Imperial Institute* (vol. 20, No. 2). It was found that if barley is exposed to an atmosphere containing a large amount of moisture, its germinating capacity is seriously reduced and may even be destroyed entirely. Such a condition of the atmosphere exists in North-eastern India during the period of the monsoon, *i.e.* after May, and consequently the germinating power of barley shipped from Calcutta after May is liable to be low. Barley produced in North-western and Central India would not meet with adverse conditions at any time, and although the humidity of the atmosphere along the sea-board area from Karachi to Bombay is high after May, barley exported at that period from these ports would not suffer appreciably if it were not delayed long in the sea-board area. In 1912-13 nearly 300,000 tons of barley, of a total value of about 1½ million pounds sterling, were shipped from the various ports; about two-thirds from Karachi, slightly less than one-third from Calcutta, and a small quantity from Bombay. No barley has been exported to this country from India during the last three or four years, but when shipments are again made, the results of this work should be borne in mind.

**PALEOBOTANY AND EARTH-HISTORY.**—The importance of the correct determination of fossil plants from the point of view of stratigraphers is well brought out in two short papers by Prof. A. C. Seward in the *Quarterly Journal of the Geological Society of London*, vol. 78, part 3, Sept. 1922. In one, the first fossil plants recorded from Ceylon are described, from specimens collected in dense jungle by Mr. E. J. Wayland. They prove the existence of Middle Jurassic strata, comparable with those of Madras. The second paper deals with Carboniferous plants collected by Mr. J. A. Douglas on the west coast of Peru. Dr. F. Fuchs recorded plants from this locality as Carboniferous in 1900, but he included two Wealden species, which Prof. Seward is inclined to reject in the absence of further evidence. If the list now given could be regarded as representing a flora of Upper Carboniferous age, its north-European affinities and the absence of any member of the *Glossopteris* flora would give it special significance. Prof. Seward, however, states that it may be Lower Carboniferous. Mr. J. A. Douglas, in the discussion on the paper, suggested that a chain comparable in height with that of the existing Andes may have formed an effectual snow-clad barrier between the region supporting the Gondwanaland flora and that yielding a more normal Carboniferous type farther to the west.

**AMERICAN VERTEBRATE PALEONTOLOGY.**—A number of short "Contributions from the Paleontological Laboratory" of the Peabody Museum, Yale University, have of late been appearing in the *American Journal of Science* (vols. ii. to iv.). E. L. Troxell, from "A Study of Diceratherium and the Diceratheres," is led to divide the true *Diceratherium*, Marsh, of the Great Basin of Oregon, from those of the Great Plains of Nebraska and Wyoming, which he refers to a new genus *Menoceras*, and further to separate both from *Aceratherium*, Kaup. The same author, treating of "Oligocene Rodents of the genus *Ischyromys*," hazards the suggestion that this genus developed into the modern prairie-dog, *Cynomys*. Mr. Troxell has also investigated "the genus *Hyrachyus*," which he considers divisible into three groups. R. S. Lull supplies a "Restoration of *Blastomeryx marshi*" and discourses on the "Primitive Pecora in the Yale Museum," among which with other novelties is described *Nanotragulus loomisi*, gen.

et sp. nov., from the Miocene of Wyoming. M. R. Thorpe describes a "New genus of Oligocene Hyænodontidæ," from South Dakota, under the name of *Neohyænodon*. He also discusses the "Oregon Tertiary Canidæ" and "A new Merycoïdon" as well as "Aræocyon, a probable old world migrant." The last-named, founded on a jaw from the Middle Pliocene of Oregon, has its nearest ally in *Sinoocyon primigenius*; Roth, from the Pikermi beds near Athens, and should it prove to be a derivative of purely American ancestry it will, the author considers, be one of the most remarkable cases of convergence known to the science of vertebrate palæontology. Finally, in a more lengthy paper Mr. Thorpe describes "Some Tertiary Carnivora in the Marsh Collection," including new forms.

**RAIN-PRODUCING INFLUENCES IN SOUTH AUSTRALIA.**—From an examination of the rainfall records and other evidence in South Australia, Mr. E. T. Quayle has come to the conclusion that there is an area of marked rainfall improvement lying south-east from Lake Torrens, where in places it ranges as high as 20 per cent. In the Proceedings of the Royal Society of Victoria, 34 (N.S.), Pt. II., Mr. Quayle discusses the reasons of this improvement and its bearing on the reclamation of arid areas in the interior. The area of improvement in South Australia is continuous with a similar one in Victoria, and both are in contrast to areas of marked decrease to the north. Irrigation as a source of improved rainfall cannot operate in South Australia, for it has made practically no progress. Mr. Quayle finds the causes in changes in vegetation, due to settlement, and to variations in the water supply of the great inland lakes. From various data it would appear that Lake Torrens and Lake Frome are now impounding more water than formerly, but quantitative data are difficult to obtain. Certain places to the south-east or lee of the lake show increased rainfall in recent years, while places beyond its influence show a decrease. The full cause of the increase of water in these lakes is not clear, but Mr. Quayle considers that the substitution of cereal crops or grass for Mallee scrub leads to a marked increase in rainfall. The destruction of forest trees and the extension of pastoral lands are aids in local rain production. This matter is of so much importance that it is to be hoped that investigations on a larger scale will be undertaken.

**THE LIGNITE OF THE LOUGH NEAGH CLAYS.**—Evidence is accumulating to show that the Lough Neagh Clays in the counties of Tyrone and Antrim are of Oligocene rather than Pliocene age. The recent deep boring at Washing Bay has yielded to Prof. Johnson and Miss J. G. Gilmore (Sci. Proc. R. Dublin Soc., vol. 17, p. 59, 1922), through the cores preserved by the Geological Survey, material that calls forth the following interesting remark: "It needs little imagination to picture the presence of forests of Sequoia in N. Ireland, possibly contemporaneous with those in S. Devon at Bovey Tracey, the shores of the Baltic, the Rhine valley, Saxony, Silesia, and S. France. We may yet find in Ireland large deposits of lignite or brown coal of economic value like those abroad."

**THE STATEMENT OF CRYSTAL-SYMMETRY.**—Numerous minerals are known, the normal crystals of which indicate, on physical measurement, a certain type of symmetry, while the results of treating them with solvents lead to their being placed in another of the thirty-two crystallographic classes. A latent symmetry is thus revealed. E. T. Wherry (*Amer. Journ. Sci.*, vol. 204, p. 237, Sept. 1922) styles such crystals *amphisymmetric*, and regards the symmetry determined with the goniometer as that of the structure

built up by the atoms or molecules, and the latent symmetry as that of the separate atoms or molecules, with their attached electrons. This matter is ingeniously stated on p. 241. A halogen atom in sylvine, for example, may receive an electron from a potassium atom, and may then, as a complete octet, be capable of taking its place in a holosymmetric structure. When, however, it is attacked by a solvent, its low surface-symmetry, due to the presence of one electron of metal and seven of halogen, is revealed as the latent symmetry of the substance. Both classes of symmetry should be mentioned in the description of the crystal. Sylvine might thus be described as "Cubic; structurally holosymmetric; latently gyroïdal," or "Cubic, structurally of class 32, latently 29." A useful list of amphisymmetric substances is given by the author, including some not known as minerals.

**INSULATION TESTING.**—Messrs. Evershed and Vignoles, Ltd., of Acton Lane Works, Chiswick, have produced a new insulation tester which possesses several advantages over the older types. Mr. Evershed, who was the first to make a testing set consisting of a small hand dynamo and an ohmmeter, has produced many improvements on the original set during the last thirty years. His greatest improvement was when he made a "one-box" instrument in 1903 and raised the pressures produced by the hand dynamo to 500, 1000, and even higher voltages. This instrument is called the "megger" and has a world-wide reputation. The new instrument is called the "meg" insulation tester. As its weight is only 7 lb. and its dimensions are only  $5\frac{1}{2} \times 7\frac{1}{2} \times 6\frac{1}{4}$  inches, it is much lighter and smaller than any similar instrument. The case is made of cast aluminium, one end of which is formed of an oil-tight gear box. It is always ready for use and will stand rough usage. A free-wheel device protects the gear from damage and prevents the armature from being turned the wrong way. At 100 rev. per. min. it generates 500 volts, and considering its size its efficiency is most satisfactory. The price is only about half the price and the weight is less than half the weight of the well-known "megger" testing set.

**HEATING AND VENTILATION IN PASSENGER SHIPS.**—With the general advance of scientific progress many of the discomforts of sea life have been eliminated. Distilling ensured a plentiful supply of fresh water; electricity solved the problem of lighting, refrigeration that of food preservation. The accommodation of our big ships is often and rightly described as palatial. If there is any problem that has lagged behind it is that of the ventilation and heating of passenger ships, a subject which was dealt with in a paper read by Mr. J. L. Musgrave at the Institution of Heating and Ventilating Engineers on October 11. The problem is admittedly a difficult one. Not only have large numbers of passengers to be accommodated in limited spaces but the conditions of sea life change from day to day. Then, too, odours from the machinery spaces, from the paintwork, store-rooms, kitchen, bathrooms, etc., have to be prevented from reaching the living spaces, and at the same time an ample supply of fresh air, heated or cooled as the case may be, has to be kept in circulation throughout dining saloons and cabins. In his paper the author referred to these things and gave it as his opinion that though ship-building firms employ experienced men to design the ventilating and heating arrangements, the co-operation of the fully-qualified heating and ventilating engineer at an early stage of the design of the ship would lead to more satisfactory results, and that expenditure on improved ventilation would prove a profitable investment.

The Hydrogen Molecule.<sup>1</sup>

IN Prof. Crehore's papers on the hydrogen molecule, Saha's theory of electromagnetic forces is made use of, which is founded on the Einstein relativity theory. A certain type of atom is described for hydrogen, consisting of a revolving nucleus of positive electricity with two revolving negative electrons, one on either side of the nucleus, and having a common axis of revolution with it; and it is shown that the resultant of the electrostatic and electrodynamic forces acting at points the distance of which from the

In the hydrogen atom, when a disturbance takes place, the electrons will move a certain distance along the common axis about which they and the positive ellipsoid are rotating, away from the latter; and will then return to their original position. Crehore is of opinion that it will be possible, in this way, to account for the emission of various kinds of monochromatic light from the atom, and that the existence of definite quanta of luminous energy may be explained. He contemplates the adaptation of the whole of the

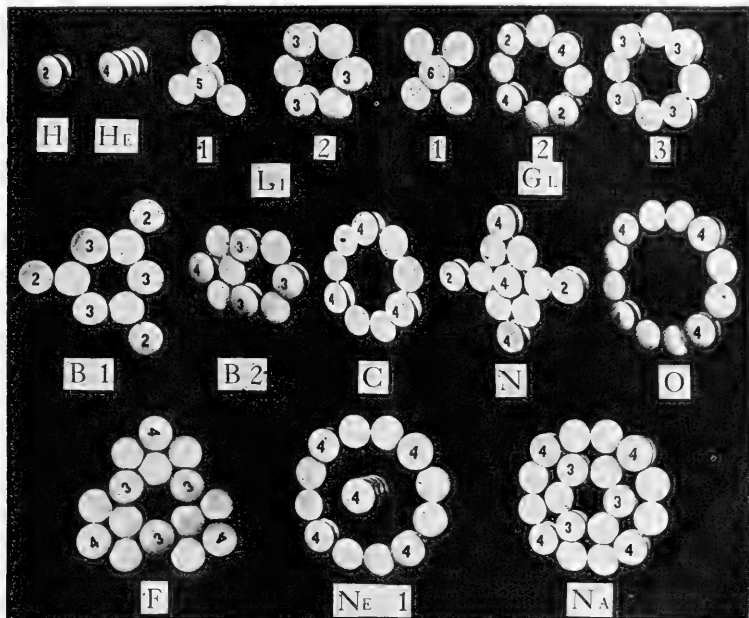

FIG. 1.—H, hydrogen atom; two coaxial, ellipsoidal electrons, on either side of positive electron with charge  $+2e$ , and mass  $1.08$ . He, helium atom, four coaxial electrons with positive nucleus between them. Li 1, discarded by Crehore. Li 2, three  $\delta$  particles with three binding electrons representing Li 7,  $N=3$ . Li 3, discarded by Crehore. Li 2 and 3 do not represent observed isotopes. B<sub>1</sub> and B<sub>2</sub>, isotopes of boron B<sub>10</sub> and B<sub>11</sub>. C, carbon with six binding electrons corresponding to the atomic number of the element,  $N=6$ . O, oxygen,  $N=8$ , eight binding electrons. F, fluorine,  $N=9$ , nine binding electrons. Ne 1, Ne 20; the helium atom at the centre is supposed to be equivalent to an addition of two binding electrons. Na, sodium,  $N=11$ , eleven binding electrons.

atom is great, compared with the distances between the atoms in a crystal, varies inversely as the square of the distance. Gravitational force is thus shown to result from the combination of electrostatic and electrodynamic forces, when relativity is taken into account. The spinning of the positive nucleus, and of the electrons, gives them an ellipsoidal form, the ratio between the major and minor diameters being in each case 3.058. For the negative electron the major diameter is  $6.514 \times 10^{-13}$  cm. and the minor is  $2.130 \times 10^{-13}$  cm. The greater part of the mass of the atom resides in the positive nucleus; and, as it is assumed to be wholly of electromagnetic origin, this nucleus is extremely minute in comparison with the negative electron, as in the commonly accepted theory of atomic structure, the solar system theory.

mathematics of Planck and of Bohr to his special form of atom.

The action of one hydrogen atom upon another, at a distance from it, is investigated, with the restriction that the axes of rotation are parallel to one another. Mathematical evidence is obtained of the possibility of certain definite positions of equilibrium for the second atom, in the field of the first, so that the two are bound together to form a molecule. Their distance apart appears to be of the order of  $10^{-8}$  cm., or enormously large, when compared with the size of the atoms. The distance is of the same order as the distances between the atoms of crystals; and it is to be supposed that similar relations to those between two hydrogen atoms, in a hydrogen molecule, exist between the atoms of sodium and chlorine, in sodium chloride; and that a number of such atoms are linked up, in

<sup>1</sup> Prof. A. C. Crehore, *Phil. Mag.*, Oct. 1921, May 1922, June 1922.

this way, into a large compound molecule or crystal. Crehore hopes that his theory will be found capable of explaining all the properties of matter, chemical affinity, valency, and the electric and magnetic properties.

Prof. Crehore has constructed a number of models consisting of wooden ellipsoids, which represent electrons, to show the structure which he assigns to the atoms of a number of elements, including several of the isotopes, which have been observed, and the atomic weights of which have been determined by Aston and Fowler, with the positive ray spectrograph. Reproductions of some of these models appear in Fig. 1; and they account for the observed atomic weights of the different elements, including those of the isotopes as determined by Aston and Fowler. The positive nuclei do not appear in the models, as the ellipsoids of revolution representing them are very minute compared with the negative electrons. Crehore assumes the existence of three different kinds of positive nuclei; those of hydrogen, with charge  $+2e$  and mass 1.008; those of helium, with charge  $+4e$  and mass four; and those of a hypothetical element with charge  $+3e$  and mass 2.333. In building the models these nuclei are combined with electrons as follows, to form positively charged particles; (1) that of hydrogen, with one negative electron, giving a particle  $H'$ , with charge  $+e$ , and marked 2 in the models to show that the charge of its nucleus is  $+2e$ ; (2) that of helium, with two negative electrons, giving an  $\alpha$  particle with charge  $+2e$ , marked 4 in the models, as the charge of its nucleus is  $+4e$ ; (3) that of helium, with three

electrons, giving a particle with charge  $+e$ ; (4) that of the hypothetical element, with mass  $2\frac{1}{3}$ , together with two electrons, positive charge  $+e$  and marked 3 in the models.

Calling this  $\delta$ , the isotope of lithium (Li 7), with atomic weight 7, is formed by a ring of three  $\delta$  particles, joined by three electrons, which may be shown developed into a straight line as  $-\delta-\delta-\delta$ . . . , the full hyphens representing the binding electrons. Beryllium is assigned the structure  $-4-2-4-$ , the two 4 particles being joined by two electrons, and the atomic weight being nine. Be 10 is a ring  $-\gamma-H'-\gamma-H'$ . . . . Carbon is represented as  $=a=a=a:::$ , oxygen as  $=a=a=a:::$ , and neon as the same ring of four  $a$  particles, with a helium atom at its centre, the common axis of the four negative electrons and one positive particle of the helium being at right angles to the plane of the ring.

It will be understood that the  $\gamma$  particle is obtained from helium by removing one electron, and the  $\alpha$  particle by removing another, from the other end of the axis, about which the electrons and the positive particle are regarded as rotating. The  $H'$  particle, with charge  $+e$ , is obtained from Crehore's hydrogen atom by removing one of the two electrons on either side of the nucleus, and the  $\delta$  particle will have two electrons, one on either side of the nucleus, and rotating about its axis. These  $\alpha$ ,  $\gamma$ ,  $H'$ , and  $\delta$  particles are held together by binding electrons to form the atomic models described above. The atomic number is in general equal to the number of the binding electrons.

### Athletics and Oxygen Supply.

IN attempting to analyse the factors which underlie muscular efficiency, most observers have been content to concern themselves with a consideration of the oxygen supply. They have devoted themselves to a study of the means by which fuel arrives at the engine rather than to a study of the behaviour of the engine itself. As a result of the work of Fletcher, Hopkins, and of Hill, we are now in a position to consider the broad question of athletic capacity from the details of the changes which we know take place in the contraction of a single isolated muscle.

We know that during the initial contraction of the muscle and the period in which this contraction is maintained, there is a liberation of lactic acid within the muscle, and that the actual contraction of the muscle is a consequence of the physical forces called into play by the appearance of this acid at various membranes or surfaces within it. The fact of great significance is that these processes in which the full force of the muscle is developed and maintained do not demand for their accomplishment any supply of oxygen whatever. While the muscle relaxes the lactic acid present is neutralised by the supplies of available alkali in the tissues, but not until the period after relaxation is complete does the oxygen consumption of the muscle begin. In this final stage, in which the muscle is apparently at rest, a process goes on which may be compared to the recharging of an accumulator, for not only is oxygen consumed but the lactic acid disappears and heat is developed.

A little reflection is sufficient to help us to realise that the sequence of changes in the isolated single muscle, in which the oxygen consumption only occurs during the final stage, has its counterpart in the processes going on in the body of a man running a race. When the running stops, he is "out of breath," that is to say he still needs oxygen in excess of his

resting requirements, for he does not, from minute to minute during the race, obtain all the oxygen necessary to oxidise the lactic acid produced in the contractions of his muscles. If he runs slowly the process of removing lactic acid will be correspondingly facilitated, for his oxygen intake will be nearly sufficient to deal with all the lactic acid produced. If, however, he runs quickly, while he does not increase his oxygen intake, he does increase his lactic acid production, and this production will soon outstrip its removal. In other words, the runner will become fatigued. Fatigue, then, is seen to be due, among other things, to the accumulation of lactic acid in the muscle, and the extent of a man's capacity as an athlete depends on the extent to which he can tolerate such an accumulation. His toleration for lactic acid will depend on the reserve of alkali which his tissues contain for neutralisation of this acid.

Prof. A. V. Hill, in a paper read before the Section of Physiology of the British Association at the recent meeting at Hull, was at some pains to point out the errors into which various observers have fallen by neglecting the oxygen consumption which takes place after running stops. They have assumed that the oxygen consumption per minute during the running represented the total energy requirement, and have in some cases arrived at the absurdity that quicker rates of running require less oxygen than do slower rates. Yet it is precisely *because* the oxygen consumption can to a certain extent lag behind the development of energy, it is *because* the isolated muscle can exert its full strength in the absence of oxygen, that a man can run 100 yards at a much greater speed than he can run 1 mile.

An interesting confirmation of the view that fatigue is due to the accumulation of lactic acid in the muscles is obtained by considering the fact that

a man of athletic frame can "run himself out" to such an extent that he requires 10 litres of oxygen at the end of exercise above his resting consumption, he will absorb this amount during the 8-10 minutes which follow the end of the exercise. Now the amount of lactic acid which this oxygen will oxidise can be calculated, and on the assumption that a man of 70 kgm. weight is using 25 kgm. of muscle, the calculation indicates that when an athletic man is exhausted, the lactic acid present will amount to 0.33 per cent. of his muscle weight. But Meyerhof has determined that the maximum percentage of lactic acid which can be produced by stimulation in isolated mammalian muscle varies from 0.3 to 0.4 per cent. The agreement between the two figures is very striking.

The fact that a runner does not consume all the oxygen he requires for running until the exercise is over may be regarded in another light. One may say that the runner gets credit for oxygen. Let us suppose that before exhaustion he can get credit for

10 litres. Then, if during exercise he breathes in 5 litres per minute, it follows that in running for 1 minute he has energy corresponding to 15 litres of oxygen at his disposal. In running for 5 minutes, however, the energy available only corresponds to  $(10 + 5 \times 5 =)$  35 litres of oxygen; that is to say, it corresponds to 7 litres per minute. Roughly speaking, the energy available per minute when running 5 minutes is less than half that available when running only 1 minute.

It was found to be possible to plot a curve showing the relation of the true oxygen consumption in running various distances at a maximum rate to the time taken. The distances chosen were those of the customary flat races. It was found that the curve was of the same general type as that obtained when the speed developed in the various world's records was plotted against the time taken. In other words, it was evident that the shape of this latter curve could have been predicted from considerations of oxygen consumption.

### The Fiftieth Anniversary of the Dutch Zoological Society.

THE fiftieth anniversary of the foundation of the Nederlandsche Dierkundige Vereeniging, which was celebrated at Amsterdam on September 24 and 25, was an event of much scientific interest.

At the meeting held in the large hall of the Amsterdam Zoological Gardens ("Natura magistra Artis") the president, Prof. J. F. van Bemmelen, of the University of Groningen, delivered an interesting address on the history of the Society. He referred in the course of his address to the important part the Society has played in the scientific investigation of the Dutch marine fauna and flora and in the establishment of the permanent Marine Biological Station at Helder, to the activity it has shown in the movements for the preservation and protection of native wild animals and to its association, in an advisory capacity, with Dutch Government Departments on questions concerning the scientific development and regulation of the marine and fresh-water fisheries.

At the conclusion of his address the following were admitted Honorary Members of the Society: Prof. O. Abel, Vienna; Prof. M. Caullery, Paris; Prof. L. Dollo, Brussels; Prof. B. Grassi, Rome; Prof. V. Häcker, Halle; Prof. S. J. Hickson, Manchester; Prof. N. Holmgren, Stockholm; Prof. T. H. Morgan, New York; Dr. F. Sarasin, Basle; Dr. J. Schmidt, Copenhagen.

On the following day, September 25, a large party of the members with their foreign guests set forth from Amsterdam in a steamboat through some of the most interesting and beautiful waterways of that part of the country to visit the new Fresh-water Biological Laboratory stationed in the river Vecht near Vreeland. A large and commodious houseboat called the *Meerval* has been fitted up with aquaria, dredging

apparatus and other appliances for systematic and biometrical investigations of the fresh-water fauna, and there is sleeping accommodation for two or three investigators and the staff. The *Meerval* can be moved about from place to place during the summer months and is laid up for the winter at Helder.

The party was received on board the *Meerval* by Dr. Redeke, the director of the Marine Biological Station and Inspector of Fisheries, who gave an account of the investigations in progress and explained the exhibits and apparatus that were displayed.

One important result of the activities of Dr. Redeke and his assistants will be the publication of periodical reports on the fauna and flora of the Zuider Zee, and particularly of that part of it which is threatened with destruction by draining. An advanced copy of the first number of these reports was shown to the visitors.

The members of the society and their guests were entertained on the Sunday night at a banquet in Amsterdam, and on the Monday were the guests of Dr. and Mrs. Redeke at lunch at Vreeland.

It was unfortunate that Prof. Caullery (Paris), Prof. Dollo (Brussels), Prof. Grassi (Rome), Prof. Morgan (New York), and Dr. Schmidt (Copenhagen) were unable to attend the celebrations; but the foreign guests who were present thoroughly enjoyed the opportunity thus given to them by their most hospitable Dutch hosts of an interchange of views on zoological problems with friends and colleagues they had not met since pre-war days.

We may congratulate the Dutch Zoological Society on the attainment of its fiftieth anniversary, and on the valuable scientific work it has accomplished since its foundation.

### Processes of Rock-Formation.

IN a long communication sent to us by Mr. J. H. Goodchild, dealing with the distribution of sodium and calcium, reference is made to Prof. J. Joly's calculation of the age of the earth from the saltiness of the sea, a calculation based on the assumption that the salt in the sea has been carried there by streams and rivers and has been derived by solution from the land. In opposition to this view Mr. Goodchild suggests that, contrary to the notions

held at the present day by geologists, salts pass from the ocean to the land, and are being fixed as new mineral combinations in the rocks through which they percolate. He regards sedimentary rocks, such as sandstone and shale, as unstable, and liable to admixture with one another as well as to modification by the action of soluble substances like salt and calcium carbonate. As examples of changes of this sort he points to the dolomitisation of limestone, the

formation of hæmatite at and near the surface, concretions in the coal measures, and vein formations of quartz, calcite, fluorspar, and barytes.

Mr. Goodchild extends this conception to the formation of metamorphic rocks, which he regards as being formed by the action of percolating solutions on unstable strata, the action of heat and pressure being an accompaniment rather than, as petrologists usually assume, the cause of the metamorphism. From this position, assuming the formation of aluminium silicates at low temperatures, Mr. Goodchild has no difficulty in explaining the formation of basalt and other igneous rocks as due to the local but intensive action on sedimentary rocks such as sandstone, shale, and limestone of solutions containing sodium, potassium, magnesium, and calcium. Hence where igneous rocks are found associated with sedimentary rocks Mr. Goodchild regards the former not as pre-existing igneous or other rocks that have been melted by heat and injected into the sediments in a molten state, but rather as portions of the sediments that have been altered locally by interaction with one another and with percolating solutions.

According to Mr. Goodchild, rock-changes in temperate climates show ample evidence of the process to which he refers, but he states that these changes are best seen under tropical conditions. He makes a strong plea for the representation in colour of tropical conditions of weathering, by artists imbued with a sense of mystery, as a means whereby observers in temperate climates may be brought to realise the real nature of the processes involved in metamorphism and the origin of igneous rocks.

For fuller details as to Mr. Goodchild's views, reference may be made to papers on "Laterization in Minas Geraes, Brazil" (*Trans. Inst. Min. Met.*, 1914, vol. 23, p. 3), and "Land Growth" (*Mining Magazine*, 1921, vol. 25, p. 75).

### University and Educational Intelligence.

**BIRMINGHAM.**—We recently announced in this column the appointment of Mr. K. N. Moss as professor of coal- and metal-mining. This appointment has now been followed by the creation of a chair of petroleum-mining, to which Mr. R. R. Thompson has been elected. Prof. Thompson was on the staff of the mining department of the University during the session 1911-12, since when he has had experience of oil-mining in Persia, Burma, and elsewhere. He has recently been Director of Lands and Mines in Trinidad, a post which he relinquished to come to Birmingham. Sir John Cadman continues to act as honorary adviser to the mining department, and with Dr. Haldane as director of Coal-mining Research, the University takes a very high place as a centre of instruction in mining in the British Empire.

**CAMBRIDGE.**—Prof. H. R. Dean, professor of pathology, has been elected to a professorial fellowship at Trinity Hall. Prof. R. M. Dawkins, of Oxford University, formerly director of the British School at Athens, has been elected to an honorary fellowship at Emmanuel College, where he was formerly a fellow. The Master of Jesus College has been appointed to represent the University on a grand committee established to make arrangements for the commemoration next February of the bicentenary of the death of Sir Christopher Wren.

Mr. F. G. Mann, Downing College, has been appointed assistant to the professor of chemistry. The Gedge Prize has been awarded to F. J. W. Roughton, Trinity College, for an essay on "Some Blood Gas Problems."

**LONDON.**—At a meeting of the Senate held on October 18, a communication was received from the Minister of Health forwarding draft heads of agreement with reference to the School of Hygiene which is to be established as a School of the University with the donation of two million dollars made for the purpose by the Rockefeller Foundation. These provide for the erection of suitable buildings on a site in Bloomsbury and the constitution of a Board of Management and a Court of Governors for the control and administration of the School. Resolutions were adopted expressing the concurrence of the University in the proposed scheme, and the very great satisfaction with which the Senate have learnt of the munificent contribution of the Rockefeller Foundation and of the intentions of the Government with regard to the maintenance of the School.

To a communication from the Clerk of the London County Council intimating the desire of the Council that the question of the Bloomsbury site for the University should be reopened, the Vice-Chancellor was requested to reply that the Senate is prepared, "should His Majesty's Government wish to explore the possibilities of the Holland Park Site or any other site in conjunction with the University, to co-operate with the Government for that purpose."

The thanks of the Senate were accorded to the Essex County Council for a grant of 500*l.* for the year 1922-1923 for distribution among the Schools of the University in the Faculties of Arts, Science, Engineering, and Economics in proportion to the number of full-time day students from that county in attendance at those Schools; also to the Stansfeld Trustees for a second donation of 40*l.* for the provision of a Stansfeld lecture to be delivered on the laws and customs affecting the relationship between men and women.

The following doctorates were conferred: *D.Sc. in Chemistry*: Mr. S. S. Bhatnagar, of University College, for a thesis entitled "Studies in Emulsions and Surface Tensions"; Mr. F. C. Toy, of University College, for a thesis entitled "Investigations of the Photographic Process"; and Mr. H. Moore, for a thesis entitled "The Influence of Chromium on Steel," and other papers; *D.Sc. in Physics*: Mr. Snehama Datta, of the Imperial College, Royal College of Science, for a thesis embodying the results of various researches in spectroscopy.

A course of eight free public lectures on "Secretion and Internal Secretion" will be delivered by Prof. Swale Vincent on November 6, 9, 13, 16, 20, 23, 27, and 30, at 5 o'clock, in the Physiology Lecture Theatre, Middlesex Hospital Medical School, Union Street, W.1. No tickets will be required.

A CONFERENCE on the report of the committee appointed by the president of the Board of Education to inquire into the position of English in the educational system of England will be held at Birkbeck College, Bream's Buildings, Chancery Lane, E.C.4, on Thursday, November 2, at 4.30. The chair will be taken by Sir Cyril Jackson, chairman of the Education Committee of the London Council.

THE University of Bristol Association of Alumni (London branch) has arranged to hold an inaugural dinner at La Renommée Restaurant, 52 Dean Street, Shaftesbury Avenue, London, on Monday, November 6, at 7.30 P.M. Lord Haldane is the president of this branch, and it is hoped that a large number of members of the University, both past and present, will be at this dinner. The Vice-Chancellor and Mrs. Loveday have already accepted an invitation to attend.



## Calendar of Industrial Pioneers.

**October 29, 1874.** John Laird died.—One of the chief pioneers of iron shipbuilding, Laird, who was born in Greenock in 1805, was the son of William Laird, who established a boiler-making works at Birkenhead. As a partner with his father, in 1829 he built an iron lighter of 60 tons, and in 1833 built the iron paddle steamer *Lady Lansdowne*. Laird also built the first iron vessel in the Royal Navy, and in 1839 built the *Nemesis* for the East India Company, the first iron steamer to carry a gun and to steam round the Cape. The famous Birkenhead Iron Works were established by him.

**October 30, 1823.** Edmund Cartwright died.—The inventor of the power loom, which he brought out in 1785, Cartwright was born in the Midlands in 1743, was a student of University College, Oxford, and entered the Church. While holding the living of Goadby-Marwood in Leicestershire a visit to Arkwright at Matlock turned his attention to weaving, and within a year he had made the great invention by which he is remembered. His loom was employed but little till the 19th century, but in 1809 he was granted a sum of 10,000*l.* by Parliament. Cartwright also made improvements in woolcombing and in agriculture, and assisted Fulton in some of his experiments in steam navigation.

**October 30, 1880.** Sir Thomas Bouch died.—Born in Cumberland in 1822, Bouch was trained as a railway engineer and in 1849 became manager of the Edinburgh and Northern Railway. He constructed some 300 miles of railway, instituted steam ferries on the Forth and Tay, and between 1870 and 1877 built the first Tay Bridge, nearly two miles long. This bridge consisted of 85 spans, some of the wrought-iron lattice girders being 245 feet long. It was completed in September 1877, and opened for traffic in May 1878. During a hurricane on the evening of December 28, 1879, the central portion with an entire train and 70 passengers fell into the Tay.

**October 30, 1898.** Josiah Latimer Clark died.—A distinguished electrical engineer, Clark began life as a chemist, and after engaging in railway work, in 1850 joined the Electric and International Telegraph Company. His principal work lay in the field of submarine telegraphy and he was concerned with the laying of many cables, mainly in the East. He was also an original investigator, assisted to found the Institute of Electrical Engineers, and in 1874-75 served as president.

**November 1, 1856.** John Urpeth Rastrick died.—Trained under his father as a mechanical engineer, Rastrick took an important part in introducing railways into the country. He effected improvements in locomotives, was one of the judges at the Rainhill trials of 1829 who decided in favour of Stephenson's *Rocket*, assisted Stephenson to survey the Birmingham and Manchester Railway, and with Sir John Kennie was engineer to the London and Brighton line.

**November 4, 1917.** William Du Bois Duddell died.—Recognised as a brilliant investigator of electrical phenomena, Duddell was trained as an engineer at Colchester and then worked under Ayrton at the Central Technical College, London. His discovery of the singing arc formed the starting point in the development of the Poulsen arc, while his oscillograph marked an epoch in the experimental investigation of alternating current phenomena. He was a Fellow of the Royal Society and served as president of the Röntgen Society and of the Institution of Electrical Engineers. E. C. S.

## Societies and Academies.

LONDON.

**Optical Society, October 12.**—Prof. F. J. Cheshire, vice-president, in the chair.—L. C. Martin: A physical study of coma. A specially designed microscope objective and mounting, calculated to exhibit coma in the absence of spherical aberration and astigmatism, are described. Photographs of a star image, taken when the amount of coma is equivalent to that for which the light distribution has been calculated, verify the numerical work. The photometric examination of the photographic image is carried out by a special method.—F. W. Preston: Comparison of the structure of sand-blasted and ground glass surfaces. Glass surfaces smoothed or "greyed" by loose abrasives in the usual way are compared with those produced by sand blasting. The surfaces are practically indistinguishable either by the naked eye or the microscope, and the development of the structure by etching shows that the structure is virtually identical. Thus it appears that mere pounding of a glass plate can, and does, produce a surface which is structurally indistinguishable from a smoothed surface of a technical order.

PARIS.

**Academy of Sciences, September 18.**—M. Emile Roux in the chair.—L. Cuénot and Raymond Poisson: The development of some coaptations of insects. Coaptations are defined as mechanical arrangements formed by the reciprocal adjustment of two independent parts, like a key and a lock. Examples of such processes are given from *Nepa cinerea* and *Ranatra linearis*.—L. G. Du Pasquier: The arithmomy of quaternions.—Jean Rey: The probability of illuminating an aeroplane by the beam from an electric projector.—A. Sanfourche: The reactions between the gaseous oxides of nitrogen and alkaline solutions. The reaction generally assumed to take place occurs only when the alkali is in excess at every point. If there is any local deficiency of alkali, the gas reacts with water producing nitric acid and nitric oxide. Sulphuric acid is preferable as an absorbent.—Paul Riou: The velocity of absorption of carbon dioxide by ammoniacal solutions. Experimental results on the velocity of absorption of carbon dioxide by solutions of ammonium carbonate, with varying concentrations of salt and with varying temperatures.—P. Russo: New indications of the Trias in eastern Morocco.—Jean Bathellier: The rôle of the soldiers in *Eulermes matangensis*. In fighting, the soldiers of this species eject a sticky fluid, insoluble in water, which rapidly reduces their opponents to immobility. If the nest is broken, the workers are protected during the process of reconstruction by a line of soldiers, which follows the contour of the gallery under repair.—F. Dienert and P. Etrillard: The possibility of the existence of organisms in rocks capable of reviving after sterilisation by heat. A repetition of some experiments by M. Galippe. The results of M. Galippe were not confirmed: the rocks were sterile after prolonged heating to 180°C.

**September 25.**—M. L. Maquenne in the chair.—The Perpetual Secretary announced the death of M. Battandier, correspondent for the section of Botany.—P. Urysohn: The ramification of the Cantorian lines.—M. Seigle: The principal characteristics of mild steel bars previously broken by traction. It has been generally held that a steel hardened by extension is breakable and dangerous to use. Tests

on bars of mild steel broken by pulling show that this view is not exact. Details of the various tests to which the bars were submitted are given.—P. Chevenard: Nickel alloys retaining their rigidity over an extended temperature range. The alloy in the form of wire was heated to a constant temperature and loaded with a weight; an automatic arrangement recorded photographically the elongation as a function of the time. Curves are given for nickel, electrolytic iron, and for four alloys. A nickel-chromium-tungsten alloy was the most resistant to high temperatures.—L. J. Simon: The direct oxidation by oxygen or air of the esters of the alcohol acids. Methyl, ethyl, butyl, and amyl lactates when heated in a current of air undergo oxidation, giving the pyruvates in notable proportion. Ethyl glyoxylate can similarly be recognised as one of the products of oxidation by air of ethyl glycolate.—E. Fournier: The nature and structure of the substratum of the Jura chain. An account of the strata pierced by an experimental boring at Chazlot (near Rougemont) carried to a depth of 700 metres.—L. Eblé: Magnetic measurements in the Paris basin. The results given for 41 stations form part of a new magnetic survey of France. The secular variation of the magnetic elements between January 1, 1896, and January 1, 1922, was practically the same for all the stations; the mean values were: declination  $-2^{\circ} 58'$ , inclination  $-0^{\circ} 32'$ , horizontal component  $+0.0014$ . These are almost exactly the values obtained at the central station of Val-Joyeux.—Marcel Mirande: The influence of light on the formation of anthocyanine in the scales of the bulbs of lilies. It has been shown experimentally that the only radiations taking an active part in the reddening of the scales are those in the luminous part of the spectrum: there is a first maximum effect in the red, a much more important maximum in the indigo blue, and a minimum in the green.—L. Berger: The existence of an ovarian gland, homologous with the testicular interstitial gland.—L. Carrère: The dilator of the pupil in the selacians.—Paul Wintrebert: The cartilaginous pterygoid in the urodeles.

## SYDNEY.

Royal Society of New South Wales, September 6.—Mr. C. A. Sussmilch, president, in the chair.—R. H. Cambage: Acacia seedlings, Pt. VIII. A number of seedlings of different species were described. A seed of *Acacia melanoxylon* germinated after having been continuously immersed in sea water for five years. The phyllodes of various species of Acacia, such as *A. conferta*, *A. elongata*, *A. floribunda*, and *A. longifolia*, close up towards the stem at night.—M. B. Welch: Relationship between oil glands and oil yields in the Eucalyptus. Measurements made of the oil glands in the leaves of different Eucalyptus show that the oil yield on distillation is not absolutely dependent on the number and size of the oil glands.—S. Dodd: Poisoning of sheep by *Solanum cinereum*. Feeding experiments proved the berries to be very poisonous. The active principle is probably solanin. Half a pound of dried ripe berries given whole were innocuous, but the same amount mashed with water caused death to sheep in six hours. The probable reason for this is that when dry and whole they passed into the rumen, where they became mixed with other food; at the end of each rumination the total amount of fruits re-swallowed was insufficient to produce poisoning. In the other case the soluble alkaloid passed direct into the digestive stomach, etc., and the amount absorbed, being lethal, death resulted.

NO. 2765, VOL. 110]

## Diary of Societies.

MONDAY, OCTOBER 30.

ROYAL COLLEGE OF SURGEONS OF ENGLAND, at 5.—Prof. Shattock: Specimens of Foreign Bodies.  
ROYAL PHOTOGRAPHIC SOCIETY OF GREAT BRITAIN, at 7.—W. B. Appleton: Past and Present Methods of making Photographic Lenses.

TUESDAY, OCTOBER 31.

ROYAL HORTICULTURAL SOCIETY, at 3.—C. T. Musgrave: Methods of Propagation in an Amateur's Garden.

WEDNESDAY, NOVEMBER 1.

SOCIETY OF PUBLIC ANALYSTS AND OTHER ANALYTICAL CHEMISTS (at Royal Society), at 8.—G. Ainsworth Mitchell: The Colorimetric Estimation of Pyroxyalol, Gallotannin, and Gallic Acid.—Dr. H. E. Amett and M. N. Bose: The Estimation of Narcotine and Papaverine in Opium.—J. R. Nicholls: The Estimation of Morphine.—R. L. Morris: Further Notes on the Estimation of Potassium; by Perchlorate and Cobaltinitrite Methods.

THURSDAY, NOVEMBER 2.

ROYAL SOCIETY, at 4.30.—*Probable Papers*.—Lord Rayleigh: Polarisation of the Light scattered by Mercury Vapour near the Resonance Periodicity.—Prof. G. P. Thomson: The Scattering of Hydrogen Positive Rays and the Existence of a powerful Field of Force in the Hydrogen Molecule.—H. D. Smyth: A new Method for studying Ionising Potentials.—I. Backhurst: Variation of the Intensity of reflected X-radiation with the Temperature of the Crystal.—S. Datta: The Absorption Spectrum of Potassium Vapour.—K. R. Ramanathan: The Molecular Scattering of Light in Vapours and in Liquids and its Relation to the Opalescence observed in the Critical State.

LINNEAN SOCIETY, at 5.

ROYAL COLLEGE OF PHYSICIANS, at 5.—Sir Maurice Craig: Mental Symptoms in Physical Disease (Bradshaw Lecture).

ROYAL AERONAUTICAL SOCIETY (at Royal Society of Arts), at 5.30.—Major A. R. Low: A Review of Aircirc and Helicopter Theory, with Acroplane Analogies.

CHILD-STUDY SOCIETY (at Royal Sanitary Institute), at 6.—Dr. P. B. Ballard: A Defence of Mental Tests.

INSTITUTION OF ELECTRICAL ENGINEERS, at 6.—F. Gill: Inaugural Presidential Address.

CHEMICAL SOCIETY, at 8.—N. V. Sidgwick and W. M. Dash: The Solubility and Volatility of the Nitrogenaldehydes.—R. H. Pickard, J. Kenyon, and H. Hunter: Investigations on the Dependence of Rotatory Power on Chemical Constitution. Part XIII. The Spatial Configuration of the Unbranched Aliphatic Chain.—J. Kenyon and R. A. Nicol: Investigations on the Dependence of Rotatory Power on Chemical Constitution. Part XIV. The Normal Aliphatic Ethers of *n*-*o*-octanol.—H. Phillips: Investigations of the Dependence of Rotatory Power on Chemical Constitution. Part XV. The Normal Aliphatic Ethers of *n*-methylbenzylalcohol.—H. Phillips: Investigations on the Dependence of Rotatory Power on Chemical Constitution. Part XVI. A new type of Walden Inversion.—L. Hall: Investigations on the Dependence of Rotatory Power on Chemical Constitution. Part XVII. The *dl*-*o*-*o*-cetyl Esters of the Acids of the General Formula  $C_3H_7(COOH)_n$ .—F. L. Pyman: Orientation of the 1:4- and 1:5-dimethylglyoxalines. Mode of Fission of 5-amino-2-glyoxalines.—L. Light and F. L. Pyman: Bromo-derivatives of 2-methylglyoxaline.

INSTITUTION OF BRITISH FOUNDRYMEN (at Institute of Marine Engineers), at 8.—P. A. Melmoth: Notes on the Development of the Manufacture of Steel Castings.

FRIDAY, NOVEMBER 3.

INSTITUTION OF MECHANICAL ENGINEERS, at 8.—Sir Frank Baines: Repairs to the Roof of Westminster Hall.

JUNIOR INSTITUTION OF ENGINEERS, at 7.30.—T. H. Sanders: Laminated Springs.

PUBLIC LECTURES.

SATURDAY, OCTOBER 28.

HORNIMAN MUSEUM (Forest Hill), at 3.30.—F. Balfour-Browne: The Life and Habits of Mason Wasps.

MONDAY, OCTOBER 30.

CITY OF LONDON Y.M.C.A. (186 Aldersgate Street), at 6.—Sir William M. Bayliss: The Unity of the Human Body.

WEDNESDAY, NOVEMBER 1.

UNIVERSITY COLLEGE, at 5.30.—Dr. P. Harting: Holland, the Land and its People.—S. Jones: Some Recent Results in Experimental Phonetics.

THURSDAY, NOVEMBER 2.

FINSBURY TECHNICAL COLLEGE, at 4.—Prof. C. H. Desch: The Metallurgical Chemist (Streatfield Memorial Lecture).

UNIVERSITY COLLEGE (in Physics Lecture Theatre), at 5.30.—Prof. E. G. Coker: Recent Photo-Elasticity Researches in Engineering Problems.

CITY OF LONDON Y.M.C.A. (186 Aldersgate Street), at 6.—Prof. H. Maxwell-Lefroy: How Insect Pests are tackled.

FRIDAY, NOVEMBER 3.

BEDFORD COLLEGE FOR WOMEN, at 5.30.—Miss C. A. J. Skeel: Ancient Travel.

UNIVERSITY COLLEGE, at 8.—Prof. G. Dawes Hicks: The Philosophy of Religion. Succeeding Lectures on November 10, 17, 24, December 1 and 8.

SATURDAY, NOVEMBER 4.

HORNIMAN MUSEUM (Forest Hill), at 3.30.—E. Lovett: The Folklore of the Cat.

# NATURE

A WEEKLY ILLUSTRATED JOURNAL OF SCIENCE.

*"To the solid ground  
Of Nature trusts the mind which builds for aye."*—WORDSWORTH.

No. 2766, VOL. 110]

SATURDAY, NOVEMBER 4, 1922

[PRICE ONE SHILLING

Registered as a Newspaper at the General Post Office.]

[All Rights Reserved.]

## NEWTON'S (New Model) "DEMONSTRATOR'S" LANTERN

For all classes of  
Projection Work.

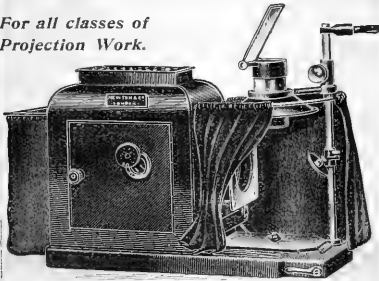

Price List sent on application.

NEWTON & Co., 72 Wigmore St., London, W.1.  
(Specialists in Optical Projection Apparatus.)

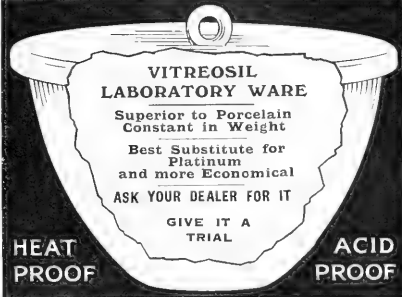

VITREOSIL  
LABORATORY WARE

Superior to Porcelain  
Constant in Weight

Best Substitute for  
Platinum  
and more Economical

ASK YOUR DEALER FOR IT

GIVE IT A  
TRIAL

HEAT  
PROOF

ACID  
PROOF

SOLE MANUFACTURERS

THE THERMAL SYNDICATE, LTD.,  
VITREOSIL WORKS—WALLSEND-ON-TYNE.  
LONDON DEPOT—28 VICTORIA ST., S.W.1.  
AND AT PARIS AND NEW YORK.

## BAIRD & TATLOCK (LONDON) LTD.

SCIENTIFIC INSTRUMENT MANUFACTURERS  
and LABORATORY FURNISHERS.

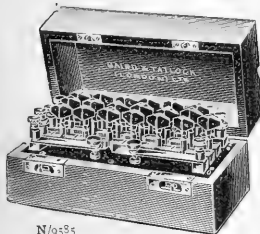

N/9595  
RESISTANCE BOX

Physical  
Apparatus  
for  
Schools  
and  
Colleges.

14-15 CROSS STREET HATTON GARDEN LONDON E.C.1



CERTIFICATE  
OF  
EXAMINATION  
OF  
Fahrenheit Thermometer No. 0.10550, etc.

Name on Thermometer — Negretti & Zambra.

Conforms to be applied to the Scale Readings determined by comparison with the Standard Instruments at the National Physical Laboratory, Teddington. The corrections are given to the nearest 1/10°.

Reading	Correction
32.0°	+0.0
33.0	0
40.0	0
50.0	+0.1
60.0	+0.2
70.0	+0.3
80.0	+0.4
90.0	+0.5

Note 1. When the top of the column in the quantity filled in to be added to the observed scale reading and when the corrected reading is required.

Note 2. This certificate refers to the Air Scale reading of 101.32 on the bar by which the bar was calibrated. It is not to be taken as a guarantee of the accuracy of the instrument. For the purpose of the certificate the bar was calibrated at the temperature of 15°C. The bar was calibrated at the temperature of 15°C. The bar was calibrated at the temperature of 15°C.

Date: 22nd July 1922.  
Place: Cross Street Hatton Garden, London E.C.1.

Negretti & Zambra  
London

NEGRETII & ZAMBRA

NEGRETII & ZAMBRA

**APPOINTMENTS BOARD**  
OF THE  
**IMPERIAL COLLEGE OF SCIENCE**  
**AND TECHNOLOGY,**  
SOUTH KENSINGTON, S.W.7.

EMPLOYERS requiring men who have received a thorough training in Science and Technology, and who are Diplomates or Associates of the Imperial College, or of one of its three constituent Colleges, are asked to make use of the services of the Board. No fees.

The Imperial College includes The Royal College of Science, The Royal School of Mines, and The City and Guilds (Engineering) College. The Associates of the Colleges receive thorough training in Science and Technology, including Aeronautics, Applied Optics and Optical Engineering, Biology, Chemical Technology, Chemistry (all branches), Engineering (all branches, including Metallurgy, Mining, Mining Geology and Oil Technology), Geology, Mathematics and Mechanics, and Physics.

**THE INSTITUTE OF PHYSICS.**  
**APPOINTMENTS REGISTER AND PANEL OF**  
**CONSULTING PHYSICISTS.**

The Appointments Register Committee is prepared to recommend to Public Departments, Universities and Colleges, Directors of Research, Manufacturers, and others desirous of employing or consulting fully-qualified Physicists, suitable persons possessing special knowledge of any branch of physics.

By Order of the Board,

F. S. SPIERS, Secretary.

10 Essex Street,  
London, W.C.2.

**RESEARCH PRIZE OF \$1000.**

The ELLEN RICHARDS RESEARCH PRIZE is offered for award in the year 1923. Theses by women based on independent laboratory research are eligible for competition and must reach the Committee before February 25, 1923. For circulars of information and application blank, apply to Dr. LILIAN WELSH, Goucher College, Baltimore, Maryland.

**TO SCIENTISTS, RESEARCH STUDENTS, AND**  
**SCHOLARS.**

**THE INTERNATIONAL BIBLIOGRAPHICAL SERVICE BUREAU** supplies complete Continental and American bibliographies on any scientific, literary, or medical subject. Chemical work a speciality. Extracts made. Headquarters: Vienna. English representative: "ALEXANDRIAN," 1A Longridge Road, Earl's Court, S.W.5.

**UNION OF SOUTH AFRICA.**  
**UNIVERSITY OF THE WITWATERSRAND.**

Vacancies for:

(A) PROFESSOR OF PHILOSOPHY.

Salary.—£860 per annum on scale £860-10-1100.  
Passage.—Allowance of £60 towards passage expenses.

(B) LECTURER IN PSYCHOLOGY.

Salary.—£464 per annum on scale £464-26-588.  
Passage.—Allowance of £40 towards passage expenses.

In addition, in both cases a free first-class ticket is provided from Cape Town to Johannesburg, and half-salary is paid during the voyage. Duties commence on March 1, 1923.

Applications, together with copies of testimonials as to qualifications, experience, and character, all in duplicate, must be lodged with the SECRETARY, Office of the High Commissioner for the Union of South Africa, Trafalgar Square, W.C., from whom Forms of Application and further particulars may be obtained, not later than November 22, 1922.

**KENT EDUCATION COMMITTEE.**  
**TONBRIDGE COUNTY SCHOOL FOR GIRLS.**

Required in January:—

- (1) SCIENCE MISTRESS, Chemistry and Physics. Honours Degree in Chemistry preferred. Advanced Course contemplated.
- (2) GEOGRAPHY MISTRESS. Advanced Standard.

The salary will be in accordance with the Burnham Scale.

Applications, together with a stamped and addressed foolscap envelope, should be addressed to the Head Mistress at the School.

E. SALTER DAVIES, Director of Education.

October 10, 1922.

**AUTHORS' TYPIST.—4th year Chemical**

Student undertakes typing of scientific papers, authors' MSS., etc. Good knowledge of French and German. Box 10, c/o NATURE Office.

**LORD LILFORD'S "BRITISH BIRDS,"**  
high price will be paid for Part I. First Edition. WALKER, Bookseller, Leeds.

**BIRKBECK COLLEGE.**

(UNIVERSITY OF LONDON.)

Principal—GEORGE SENTER, D.Sc., Ph.D., F.I.C.

EVENING COURSES for the Degrees of the University of London in the Faculty of Science and for the Geography Diploma.

Facilities are also provided during both day and evening for Post-Graduate and Research Work.

Calendar, 1s.; by post, 1s. 5d. Prospectus free.

For full particulars, apply to the SECRETARY, Birkbeck College, Fetter Lane, E.C.4.

**UNIVERSITY OF LONDON.**

A Course of three Lectures in Zoology entitled "PROBLEMS OF EVOLUTION, WITH SPECIAL REFERENCE TO FISHES" will be given with lantern illustrations by MR C. TATE RIGAN, M.A., F.R.S., Keeper of Zoology in the British Museum (Natural History), at UNIVERSITY COLLEGE, LONDON (Gower Street, W.C.1), on FRIDAYS, November 10, 17, and 24, 1922, at 5-15 P.M. At the first Lecture the Chair will be taken by Professor D. M. S. WATSON, F.R.S., Jodrell Professor of Zoology and Comparative Anatomy in the University. ADMISSION FREE, WITHOUT TICKET.

EDWIN DELLER, Academic Registrar.

**THE MANCHESTER MUSEUM.**

The Council of the Manchester University invite applications for the post of KEEPER of the MUSEUM. Preference will be given to candidates who are University graduates in Natural History subjects. Applications must be sent in before Saturday, December 2. Information as to the duties and stipend of the post will be supplied in response to enquiries addressed to the SECRETARY of the Manchester Museum.

**OERTLING BALANCE (long beam) wanted,**  
second hand,agate knife edges and planes, first-rate condition not essential. Apply Box 25, c/o NATURE Office.

**WANTED.—Roscoe and Schorlemmer's**  
Treatise on Chemistry, Vol. II. 1907 or later. Particulars to Box No. 26, c/o NATURE Office.

**ACCURATE CHEMICAL THERMOMETERS.—**

110° C., 150° C., 200° F., 300° F., 25.; 200° C., 25. 6d.; 360° C., 400° F., 3s.; 500° C., gasfilled, special glass, 10s. Beckmann Thermometers with Auxiliary Scale, 7/8" C., 17s. 6d. each.—CHEELD, Chesham.

**The Misses FARRAN**

**10 Bell Yard, Temple Bar, W.C.2.**

**HAVING CONSIDERABLE EXPERIENCE IN**  
**COPYING SCIENTIFIC MS.**

AND ARE PREPARED TO  
UNdertAKE ANY QUANTITY.

**SECOND-HAND MICROSCOPES**

ZEISS Microscopes in stock from . . . . .	£30 0 0
LEITZ " " " " " " " " " " " " " "	15 15 0
WATSON " " " " " " " " " " " " " "	5 0 0
BECK " " " " " " " " " " " " " "	6 10 0
BECK Popular Binocular, complete outfit . . . . .	9 9 0
CROUCH Binocular Outfit " " " " " " " " " "	15 15 0
SWIFT Medical Outfit, 3", 3 1/2", 1/2" mechanical stage, case . . . . .	19 19 0
SPENCER LENS Outfit, 3", 3 1/2", 1/2" " " " " " " " " " " " "	17 10 0
WATSON Edinburgh H, 3", 3 1/2", 1/2" " " " " " " " " " " " "	27 10 0
HARTNACK Microscope, complete " " " " " " " " " " " " " "	3 3 0
Botanical Students' Models, from " " " " " " " " " " " " " "	3 10 0

List on request.

Repairs to any Microscope—Exchanges made.

**BROADHURST, CLARKSON & Co.**  
NOTE ADDRESS—  
**63 FARRINGTON ROAD, LONDON, E.C.1.**



SATURDAY, NOVEMBER 4, 1922.

CONTENTS.

	PAGE
Primitive Custom and Administration . . . . .	593
Applied Electricity . . . . .	595
Spitsbergen and its Wild Life. ( <i>Illustrated.</i> ) By W. E. C. . . . .	597
The Reopening of Europe. By Prof. Grenville A. J. Cole, F.R.S. . . . .	599
History of Astronomy. By J. L. E. D. . . . .	600
Our Bookshelf . . . . .	601
Letters to the Editor :—	
Action of Cutting Tools. ( <i>Illustrated.</i> )—A. Mallock, F.R.S. . . . .	603
One Possible Cause for Atmospheric Electric Phenomena: A Reply.—Dr. G. C. Simpson, F.R.S. . . . .	604
The Green Ray at Sunset and Sunrise.—Capt. C. J. P. Cave; Prof. W. M. Flinders Petrie, F.R.S. . . . .	604
A Broadcast "Rainbow."—Prof. R. C. McLean . . . . .	605
Colour Observations of the Moon.—A. F. Warth . . . . .	605
The Local Handbook of the British Association.—Bernard Hobson . . . . .	605
The Early History of the Land Flora.—I. By Dr. D. H. Scott, F.R.S. . . . .	606
Solar Radiation and its Changes . . . . .	608
Obituary :—	
W. H. Wesley. By Dr. A. C. D. Crommelin . . . . .	609
Prof. C. Michie Smith . . . . .	610
Current Topics and Events . . . . .	610
Our Astronomical Column . . . . .	613
Research Items . . . . .	614
The Origin of Magnetism. By Prof. A. O. Rankine . . . . .	616
Man and the Ice Age . . . . .	617
Generation and Utilisation of Cold. ( <i>With diagram.</i> ) By E. A. Griffiths . . . . .	618
Propagation of the Sound of Explosions . . . . .	619
The Whitworth Scholarships . . . . .	620
University and Educational Intelligence . . . . .	620
Calendar of Industrial Pioneers . . . . .	622
Societies and Academies . . . . .	622
Diary of Societies . . . . .	624

*Editorial and Publishing Offices :*

MACMILLAN & CO., LTD.,

ST. MARTIN'S STREET, LONDON, W.C.2.

Advertisements and business letters should be addressed to the Publishers.

Editorial communications to the Editor.

Telegraphic Address: PHUSIS, LONDON.

Telephone Number: GERRARD 8830.

NO. 2766, VOL. 110]

Primitive Custom and Administration.

THE Report of the Tanganyika Territory for the year 1921, which has been issued as a White Paper (Cmd. 1732), contains much matter of interest relating to native affairs. It is evident that the Administration by sympathetic treatment and by a patient hearing of tribal grievances is winning the confidence of the native population, while every opportunity is being seized to remove hardships which have been inflicted on them by the excessive alienation of land under the German colonial system. As a census taken in April last shows that there is a native population of 4,107,000, the responsibility for the regulation of native affairs is not light. It is satisfactory, therefore, to note that a good beginning has been made towards establishing sympathetic relations with the tribes. In the interests of the Territory, it is vital that the administration should be conducted with due regard to native customs and institutions. It is even more important that the native should have an opportunity of development along lines in harmony with his own culture, and ultimately, it is permissible to hope, of incorporation as an essential and responsible element in the community.

In this connexion a reference in the report to native beliefs assumes a significance which might, perhaps, be overlooked. It is stated that in the Mwanza region the reigning chief has lost his authority through having failed to live up to his father's reputation as a rain-maker, and that witch-doctors are losing their hold over the younger generation. These statements do more than throw an interesting light on the religious beliefs of the people. The combination of function of chief and rain-maker is not uncommon throughout Africa. It is one of the marks of "the divinity that doth hedge a king" among primitive peoples. Its special significance lies in the fact that not only is the person of the king or chief sacred, but his authority also rests upon his power as a sacred being, of which rain-making is one of the manifestations. The magic of the witch-doctor or medicine-man, like that of the king, is on the side of law and order, notwithstanding the, to us, sinister character of certain of his activities. Some of the great secret societies of West Africa, which are essentially religious in character, have, as one of their more important functions, the policing of their respective districts and the punishment of any transgression of the moral or social code. It follows, therefore, that any change in attitude towards the religious beliefs which form the basis of authority cannot fail to have a harmful effect on the discipline of the community. Any indication of a weakening in the regard

which the natives of Tanganyika have for the magic powers of their chiefs and witch-doctors must cause misgiving. It indicates a decay of custom which may effect the most vital elements in native culture and social organisation.

A part of the Empire far distant from Central Africa affords a striking example of a decay of custom similar to that now taking place in Tanganyika. Over the greater part of the South Seas the sacrosanct character of the chief is, or was, the basis of the whole social order. The sacred power of the chief was the sanction of the law, and in virtue of it he punished offenders. Contact with civilisation has proved fatal. The white man does not recognise the sanctity of the chief, nor does he discriminate in this respect between the chief and the ordinary members of the tribe. When he commits, without fatal consequences, acts which the native regards as tabu, the sacred character of the chief is impaired and his authority undermined. As the laws of morality, of the sanctity of married life, and of property rest on the principle of tabu, of which the chief is the supreme manifestation, not only is the authority of the chief to punish offenders questioned, but the whole social order is also disintegrated. The results can be studied in Melanesia, and particularly in the New Hebrides, where contact with the white man has led to the discrediting in this way of the authority of the chief and of the elders of the community.

The social disintegration which has followed this result need not be considered here in detail. It has been detrimental to the native, and, by depleting the supply of labour, will ultimately have a serious effect on the development of the resources of the islands. Those who would pursue the subject further will find it well and impartially discussed in "Essays on the Depopulation of Melanesia,"<sup>1</sup> which has recently been published on behalf of the Melanesian Mission. In this instructive, and indeed valuable little book, a number of essays by missionaries, an anthropologist, and administrative officials such as Sir William Macgregor and Mr. C. M. Woodford, deal with various aspects of the question. All concur in attributing much importance to the decay of custom as a cause of the depopulation which is undoubtedly taking place in this area.

The adjustment of custom when civilised and primitive meet must inevitably give rise to difficulty. It should be the aim of the ruling power to secure this adjustment with as little harm as possible to the social organisation of the subject population. It is unnecessary to urge that certain practices cannot be tolerated under the rule of a civilised power. Human sacrifice,

for example, is a case in point. It has been usual to forbid such practices entirely, as was done in the case of suttee in India. Frequently, however, total suppression entails consequences entirely unforeseen. As our knowledge of primitive peoples grows, it becomes increasingly apparent that it is difficult to interfere with one element in custom without affecting the whole. In Melanesia, head-hunting and intertribal wars have been suppressed. The results have been serious. It is not merely that these forms of activity have disappeared, but with them has gone a whole group of dependent social activities which filled the life of the Melanesian. A head-hunting expedition entailed the performance of a prolonged ritual of preparation, extending over many months, which began with the building of canoes, and included at different stages many feasts and the preparations for them. A whole group of interests, many of practical utility apart from their main object, has thus been eliminated from the lives of the natives.

The late Dr. W. H. R. Rivers, in an interesting essay which he contributed to the work mentioned above, gave it as his opinion that the most important factor contributory to the depopulation of Melanesia was psychological, and, in fact, that it was due to the lack of interest in life which followed as a consequence of the suppression of certain customs. It is interesting and significant to note, as an indication of the importance of this side of the subject, that it has led even a missionary to regret the suppression of intertribal war. It might well be worth while in such cases to endeavour, by substituting some harmless element, such as, for example, an animal instead of a human victim, to avoid total suppression of a custom embodying some objectionable features. This suggestion was put forward by Dr. Rivers; but something of the same nature is already in operation in districts in New Guinea, where the head-taking propensities of the native have been turned to account among animals which played havoc with the women's plantations.

The whole question is one of extreme difficulty and complexity. To those who realise our responsibilities to subject populations and the importance of the part the native should play in the development of tropical and subtropical lands, any suggestion of change in custom, such as that reported from Tanganyika, is big with possibilities of disaster. As a result of past experience, it is clear that each case must be dealt with on its merits and as it arises; but the general principle is equally clear that it is only by close and sympathetic study of native custom that it will be possible to avoid action which may undermine authority and destroy a social fabric upon which depends the continued existence of a primitive people.

<sup>1</sup> "Essays on the Depopulation of Melanesia," Edited by Dr. W. H. R. Rivers. Pp. xx+116. (Cambridge: At the University Press, 1922.) 6s. net.

### Applied Electricity.

*A Dictionary of Applied Physics.* Edited by Sir Richard Glazebrook. Vol. II. *Electricity.* Pp. vii + 1104. (London: Macmillan and Co., Ltd., 1922.) 63s. net.

IT is interesting to compare the second volume of Sir Richard Glazebrook's "Dictionary of Applied Physics" with the electrical portions of older dictionaries. For example, in Barlow's "Dictionary of Pure and Applied Mathematics" (1814) it is said that "the science of electricity became a general subject of conversation" after the discovery of the "Leyden Vial." In Nichol's "Cyclopædia of the Physical Sciences" (1860) we learn that electrical science "has spoken for itself to the world as no other has." "Witness the simultaneous discovery of the Leyden Phial and the Electric shock." Three practical applications of electricity are given, namely, the lightning-conductor, the electric telegraph, and electroplating. The last is specially commended as being "so conducive to the comforts and elegancies of life." An examination of the volume under review will show how greatly our knowledge has been widened during the last sixty years. We were sorry, however, not to have seen the "Leyden Jar" mentioned.

The plan of the dictionary follows to a certain extent that adopted by Nichol, but the important sections are much larger. In fact, quite substantial books could be made of the sections written by some of the contributors. Besides the important contributions there are a few short articles and many definitions of electrical quantities, machines, instruments, and methods. The absence of an index makes it difficult to find out whether any subjects have been omitted or not. There is a very elaborate name-index, but this will be little help even to the older physicist or electrician, as many of the names will be unknown to him. We think that the younger physicist will have considerable difficulty in finding out what he wants. Doubtless, this will be remedied when the final volume is published. We have not noticed anything about electric traction, electric ship-propulsion, electric vehicles, lightning-conductors, rotary and frequency converters, electrostatic machines, the attraction between electrified spheres, or the fixation of nitrogen. We take it that atmospheric electricity will come under meteorology in the next volume.

We were glad to notice that the contributors had not been handicapped by being compelled to adopt a rigid nomenclature and an invariable set of symbols. As a rule, those agreed on internationally have been adopted. Although considerable use has been made throughout of elementary vector analysis, there is

little demand made on the reader's knowledge of mathematics. Academical subjects, like spherical harmonics and the perennial "electrified ellipsoid," have been omitted.

Dr. Rayner has written a useful section on alternating-current instruments and measurements. He has made a happy selection of the best modern measuring instruments. His description of the electrostatic watt-meter is specially good. Occasionally his straining after conciseness leads him into inaccuracy; as when he says (p. 11) that the torque is equal to the square of the volts instead of being merely proportional to that quantity. There is a misprint also in the equation on this page. The articles on primary batteries, accumulators, and cables are good, but the last could have been expanded with advantage. The assumption on p. 94 that the thermal emissivity is independent of the radius of the wire is certainly not true, and we doubt whether the formulæ given on p. 95 are of general application.

Mr. Albert Campbell contributes a valuable article on electrical capacity and its measurement. He generally refers to capacity as "capacitance," which is the name the Americans now use, and he calls the capacity between two conductors the "working capacity." He clearly recognises the difference between two of the various kinds of capacity and calls them by different names. In other parts of the volume, however, which capacity is meant is not so clear. For example, under units (p. 948), we read that a conductor which had a capacity of 1 farad "even though composed of plates very close together, would be very large." It looks as if conductor were a misprint for condenser. The various kinds of capacities have been clearly defined by nomenclature committees of the Physical Society and of the Institution of Electrical Engineers. On p. 107 formulæ for the capacity between two circular plates and the capacity to earth of one of them are given; the formulæ are only approximations and no limitations to their accuracy are given. Their value is therefore doubtful. We note misprints in formulæ (27), (50), (54), and (55).

T. Gray's results for the dielectric strengths (now usually called the electric strengths) of air at different thicknesses are given. We think that this is a misleading way of interpreting the experimental results. If we consider spherical electrodes in air, the disruptive voltages are computed in everyday work from their distance apart and their radii, with a maximum inaccuracy of about 1 per cent. From these experiments we would conclude that the assumption that the electric strength of air was 27.4 kilovolts per cm. at 25° C. and 76 cm. pressure, whatever the thickness of the layer might be, would lead to very approxi-

mately correct results in nearly every case. We notice that the author adopts Kennelly's names for the absolute unit of electric quantity, capacity, and pressure. We thus get the abcoulomb, the abfarad and abstatfarad, and the abvolt. As they have never been recognised, even in America, by any technical society or institution, they are "technically irregular." It has to be remembered, however, that all good new names are introduced in this way.

We do not like the phrase "dielectric constant"; it surprises, at least mathematicians, to find that this "constant" varies with temperature. Many excellent methods of measuring capacity are given, but beginners would appreciate some little guidance as to which one to adopt in special cases.

Dr. Rayner's article on dielectrics will be appreciated by engineers, and Mr. Melsom's article on direct-current indicating instruments will be most helpful in the test-room of every factory. Mr. F. E. Smith writes an authoritative article on systems of electrical measurements which will be of great value for reference by subsequent writers. Dr. Allmand gives a concise and excellent description of the technical applications of electrolysis. Any one reading the fascinating account of the electron theory and its application to spectrum analysis, by Sir William Bragg, will find it difficult to believe that Rutherford and Bohr's theories of the atom are not substantially correct. In his description of "electrons and the discharge tube" Dr. Crowther is also very convincing.

Mr. F. E. Smith gives an illuminating account of galvanometers, including very helpful rules for choosing a galvanometer for a particular purpose. Mr. Butterworth writes a valuable account of the formulæ used for measuring inductance and gives an excellent table for computing the mutual inductance between coaxial circles. We miss, however, his own formula and that of Mr. H. L. Curtis for computing the high-frequency inductance of parallel cylindrical wires. Mr. Campbell gives a very complete account of methods of measuring inductance and gives some 200 references to papers on the subject. The method of compensating for the inductance of a coil shown on p. 402 is not as accurate as the author states, a term having been left out in the algebraical reduction shown on this page. Mr. Dye, in "Magnetic Measurements and Properties of Materials," has produced a very complete account of modern methods.

The General Electric Company gives a very brief account of "incandescence" lamps, which is excellent so far as it goes. Most readers would like to have had further data on tungsten vacuum and gas-filled lamps. The Americans are not so reticent. We note that the temperature of the tungsten filament is about

"2300° K." We take it that this is in the absolute Centigrade scale and that the K. refers to Kelvin. This is "technically irregular"; but there is a real demand by engineers and by some physicists that the absolute Centigrade scale, which is the one they use, be called the Kelvin scale, and we hope that this nomenclature will be adopted.

Prof. Honda gives a thoughtful article on the molecular theories of magnetism, and we have an account of Ewing's latest model. Dr. Chree writes a thorough and interesting account of the observational methods used in terrestrial magnetism, and Dr. Chapman describes some of the theories of terrestrial magnetism and how far the solar agent is responsible for magnetic storms and auroræ. Positive rays are described by Dr. Aston. A description is given of his mass-spectrograph and typical mass spectra are shown.

The lengthy article on radio-frequency measurements by Mr. Dye will be appreciated by workers in many research laboratories, as these methods are often of great value. We are doubtful whether it is legitimate to assume that the capacity of a coil can be represented by supposing that the coil has no capacity and that a condenser of a certain size is placed across its terminals. The formula for the high-frequency resistance of a round wire at an infinite distance away from other wires is given, but the formulæ found recently for more practical cases are not given.

Very complete accounts are given of switch-gear, telegraphy, and telephony, which will be appreciated by electrical engineers. We have only space to mention the valuable articles on vibration galvanometers, wireless telegraphy, and thermionic valves, by Mr. Campbell, Dr. Eccles, and Prof. Fortescue. Finally, the articles by Prof. Richardson and Dr. Wilson on thermionics. Mr. Smith-Rose on the use of thermionic valves, Mr. Melsom on direct-current meters, and Dr. Crowther on X-rays, are of great value.

Under units it is stated that, at the International Electrical Conference held in Paris in 1900, the Gauss was defined to be the C.G.S. unit of magnetic force, and the Maxwell was defined as the practical unit of magnetic induction. It is also stated that if we take the permeability of air to be unity and to be a pure number, the value of the Maxwell is the same as that of the Gauss. But the Maxwell is not the unit of magnetic induction density. Hence we should read in this case that a Maxwell per square centimetre is the same as the Gauss. There are several definitions of self-inductance given: that appearing on p. 727 is wrong, as the self-inductance is the linkage of the magnetic induction, and not the magnetic force, with the current. In no case is it explained how the linkages inside the conductor have to be computed. We have



noticed a few other slips and misprints. They do not appreciably detract, however, from the value of this volume, which will be welcomed by all physicists and engineers.

### Spitsbergen and its Wild Life.

*Amid Snowy Wastes: Wild Life on the Spitsbergen Archipelago.* By Seton Gordon. Pp. xiv + 206, 2 maps and 114 illustrations. (London: Cassell and Co., Ltd., 1922.) 15s. net.

ALTHOUGH the Spitsbergen Archipelago is only six hundred miles from the north pole, yet, owing to its accessibility, due to the influence of the Gulf Stream drift which reaches its western shores, it has been much visited in the summer months by naturalists and sportsmen, with the result its bird-life is better known than that of a number of continental countries. Its ornithology is en-crustured in a remarkable literature dating from 1598, which comprises no less than 150 contributions, and includes Prof. Koenig's "Avifauna Spitzbergensis," which from the beauty of its meisenbach pictures of scenery, and its excellent coloured plates of birds and their eggs, is entitled to rank among the most attractive of bird-books, while its letterpress exhausts the historical aspect of the subject down to the year of its publication, 1911.

The latest expedition was organised by the University of Oxford, and visited the archipelago in the summer of 1921 under the leadership of the Rev. F. C. R. Jourdain. Mr. Gordon accompanied the party in the capacity of photographer, and hence the main attractions of his book lie in the wealth and nature of its illustrations, about one hundred in number. These are supplemented by a series of pleasantly written chapters wherein he relates his personal observations and experiences. The scientific results of the expedition, however, will appear in due course; those relating to ornithology are being prepared by Mr. Jourdain, who is an eminent authority on the subject.

The most interesting pictures and chapters of Mr. Gordon's book are devoted to the pink-footed goose, Brent goose, long-tailed duck, purple sandpiper, grey phalarope, glaucous gull, and various nesting colonies. The chief captures made by the expedition were a number of eggs of the Bernicle goose, concerning the nesting habits of which no trustworthy information was forthcoming until 1907, when the first eggs were found at Spitsbergen by Prof. Koenig. Five nests and twenty eggs were obtained in 1921, but for some unexplained reason the nest of this bird—not yet depicted—does not appear in Mr. Gordon's series, though a chapter is devoted to it.

An interesting account is given of the coal-mining



FIG. 1.—Nesting ground of the Pink-footed Goose. From "Amid Snowy Wastes."

industry, which has been developed during recent years in Spitsbergen and now finds employment for some 1,300 miners, 1,000 of whom, some of them with their wives and families, remain through the winter. This colonisa-

tion, has been almost exterminated in places where it once occurred in hundreds. There is only one species of fox in Spitsbergen, the two species alluded to by Mr. Gordon being colour-phases due to season or age.



FIG. 2.—Red-throated Diver on its nest. From "Amid Snowy Wastes."

tion has effected some remarkable innovations, among others the establishment of no less than eight wireless stations whence messages may be despatched to Britain at a rate of fourpence per word!

The larger mammals, such as the Polar bear, walrus, and right whale, once extremely numerous, have long ago been exterminated, and now only stragglers appear at intervals as rare waifs. The faunal changes, however, are likely to be much more rapid in the future than in the past, since there is now a considerable human population—one that will doubtless soon be considerably increased—and Spitsbergen being a no-man's-land, no protection can be imposed, and its animal life will suffer accordingly. There are three characteristic animals in the archipelago which are likely to become extinct, namely, the reindeer (*Rangifer platyrhynchus*), which is endemic, the fox (*Canis spitzbergensis*), and the ptarmigan (*Lagopus hyperboreus*). The deer, once very numerous and still unsophisticated, has been ruthlessly slaughtered in recent years. The fox since the advent of the Norwegian hunter, with his traps and

Special efforts were made by the expedition to find the ptarmigan, the only resident land bird, but without success, though all their likely haunts were visited, including a valley where Mr. Gordon tells us in 1920 no less than fifty brace were shot in a single afternoon by members of the Scottish Spitsbergen Syndicate. These birds must afford poor sport, for Dr. van Oordt tells us they are so tame that they can easily be killed with stones.

The eider is another bird that is rigorously and systematically persecuted. Enormous numbers of its eggs are annually taken for food and down is collected from their nests—both for sale in Norway.

Mr. Gordon relates that one sloop, which had already 15,000 eggs on board, was still engaged in adding hundreds of eggs daily to the hoard. It is to be hoped that the rarer and more interesting species



FIG. 3.—Purple Sandpiper on its nest. From "Amid Snowy Wastes."

alluded to are also natives of the eastern isles of the Archipelago, which are so beset with ice that they are little known, and that thus they may escape extinction.

W. E. C.

### The Reopening of Europe.

*Frequented Ways: A General Survey of the Land Forms, Climates, and Vegetation of Western Europe, considered in their Relation to the Life of Man; including a Detailed Study of some Typical Regions.* By Dr. Marion I. Newbigin. Pp. xi+321. (London: Constable and Co., Ltd., 1922.) 15s. net.

A LARGE part of Europe is again open to the traveller. Dr. Newbigin, president of the Geographical Section of the British Association this year, does well to direct attention to the frequented ways, and her book asks those who follow them to adopt an appreciative outlook, casting off the insularity bred among our western isles. Insight into the relations of nature and man in Switzerland is not to be gained by selecting hotels where an English chaplain is on the staff. Dr. Newbigin has evidently suffered in this matter, and she remarks (p. 165) that the Catholic religion has the advantage "that no particular form of dress is imposed upon the worshippers." Her appreciation of the unconventional might have made her more tolerant (pp. 1 and 163) of "the superior person" who has been driven from anglicised Grindelwald to Japan or the New Zealand Alps. If she thinks that these fields are reserved for the travelling millionaire, let her consider Mr. Ralph Stock's exquisite little book on the voyage of "The Dream Ship" (1922), and see how the spirit of the Elizabethans may still carry our island-folk, both male and female, across the viewless seas.

Dr. Newbigin rather overlooks the value of a continuous traverse of a land-surface by the pedestrian, the cyclist, and the new users of highways that have not been so frequented since my lord and my lady took their own carriage into France. Automobilists are not always mere diffusers of dust and lubrication-odours; thousands are ready to respond to a training in history and geography. Dr. Newbigin conducts us inevitably by railway, and it may be noted that her information as to lines in the Eastern Alps is not entirely up-to-date. If, moreover, she prefers Basel, with good reason, as a place-name, why does she write Berne, St. Gothard, and the purely English Botzen, which should now, we presume, become Bolzano? She goes so far as to discuss (pp. 37 and 42) the merits of various tunnels through the mountains; these, after all, are the frequented ways. The *Gazette of the Cyclists' Touring Club* for August 1922 will show her, however, that even the Arlberg road is not forsaken. Again, in her essay on the Scottish Highlands, we should like to hear more of the pedestrian who travels across the glens as well as down them, in his attempt to realise their "relation to the life of man."

The author seems carried away at times by a certain vigour of self-expression, as if she had been caught in the swirls of "the revolt against civilisation." On p. 48 she writes, "latitude is only one of the factors which influence climate," and styles this "current geographical slang." Three pages on, she tilts against "latent heat," surely a very innocent antagonist. Again, has geographic environment moulded "the ferocious individualism of the Scot" (p. 261), which causes him to charge as much as 2s. 6d. for a belated breakfast on a winter's day? Is not this seeming lack of hospitality to be ascribed to the advent of tourists from the south, by way of Edinburgh, into the quiet of his ancestral wilds? Do we not remember how a cottier's wife was on the look-out for us one morning with a gift of oatcake, lest we should go hungry on a twenty-mile track under the Paps of Jura; or how a poor fisherman forced a tepid meal upon us, with the remark, "I should not like you to pass this house"? This is how the loneliness of moor and island have really affected the Gael of the old stock, despite the clan-animosities intensified by seclusion in the glens. Dr. Newbigin is at her best, and thus at a high level, in dealing with the influence of climate and land-forms on European vegetation. Had our military organisers known as much geography as is compressed into p. 55, the "mediterranean climate" would not have wrecked a band of gallant men sent up into the snows from Salonika.

Dr. Newbigin's photographs are a change from too familiar scenes. She gives us, for example, the vine-clad pergolas of Domo d'Ossola and the deforested slopes above La Grave. She certainly did not reach the latter spot by railway. In the Italian chapters, while seeking to be moderate, she cannot conceal a genuine hate of Venice; and, when she justly charms us with Ravenna, she elaborates a contrast that cannot be entirely sustained. Did the Goths consciously embrace the creed of Ulfilas because his homoian views provided a religion for "free men"? We are puzzled by the intricacies of p. 292, and are not going to allow so good a geographer to entrap us in the maze of Alexandrian controversy, or into a discussion of the Virgin enthroned with angels in Sant' Apollinare of Ravenna. It is more profitable to note that the explanation given (p. 231) of phenomena at the Solfatara confirms a suggestion recently made in *NATURE* (vol. 109, p. 559).

Dr. Newbigin's reliance on the railways leads her to call (p. 309) the Assisi-Foligno-Orte loop "an easy route" to Rome. The alluvial infilling seems to have made her forget that she is running upstream past Monte Subasio, and that clever engineering was required to get back from Spoleto by the gorge of

Narni to the Tiber. Bertarelli's "Guida itineraria del Touring Club italiano," route 180, puts the true aspect of this dissected country before the geographic tourist. Such tourists will receive much encouragement from the broad views of western lands provided in the book before us. Perhaps in another volume the author will show how intensive studies of equal value may be carried on by easy deviations from frequented ways. The piazza of Todi, 1350 feet above the sea, Foix on the Ariège, guarding one of the few passes into Spain, or Radstadt, tinkling with cattle-bells, on the high pastures of the Tauern, may serve as epitomes of their regions and of the reaction of environment on man. But Dr. Newbigin certainly does not need suggestions.

GRENVILLE A. J. COLE.

### History of Astronomy.

*Histoire de l'Astronomie.* Par E. Doublet. (Encyclopédie scientifique.) Pp. 572. (Paris: G. Doin, 1922.) 17 francs.

IN his first chapter the author passes in review the principal works on the history of astronomy, beginning with Weidler's book and ending with the great work by Duhem on the cosmical systems. Of the valuable books of Grant and R. Wolf, only the titles are given, and several others are omitted altogether. Of monographs, only Schiaparelli's first two papers are mentioned. This is natural enough, since there is plenty of evidence that the author is quite unacquainted with the rich literature of memoirs and short papers on the history of astronomy which has appeared within the last fifty years. Whenever a fact is not mentioned by Delambre, Duhem, etc., it will be looked for in vain in M. Doublet's pages, and whenever fresh light has been thrown on any subject since they wrote, he is not aware of it. Take, for example, the paragraph on Hipparchus. We are told that his diopter was in the Middle Ages called a Jacob's staff; in reality the former had a cursor with a round hole in it, and was used only for measuring small angles such as the diameters of sun or moon, while the latter was shaped like a cross, with the shorter arm movable (on p. 152 the invention of the baculus is correctly attributed to Levi ben Gerson of Avignon, as Duhem had also done). The star of Hipparchus is compared to the new star of 1572, whereas there can be no doubt that it was nothing but the comet of 134 B.C. The star-catalogue of Hipparchus is said to contain 1025 stars and to have been handed down to us by Ptolemy, but it has been shown by Boll that the catalogue probably contained only about 850 stars, while it is now universally recognised that Ptolemy's catalogue is not a mere reproduction of that of Hipparchus. Next it is stated that Hip-

parchus put the solar parallax equal to 3'; it was Ptolemy who did that, whereas Hipparchus said that it was at most a minute and a half. On the same page we read that Hipparchus determined the principal lunar inequalities with admirable precision. Hipparchus knew only one inequality, the equation of the centre; but that is, perhaps, a slip, as it is elsewhere (p. 110) mentioned that Ptolemy discovered the evection.

The most valuable part of Duhem's work is his account of Latin astronomy in the later Middle Ages, as he was able to make use of many manuscript sources. M. Doublet has done right in quoting him largely; but here, as everywhere else, the consequences of never referring to the original sources are evident. Duhem gives a very unsatisfactory account of the planetary system of Al Betrugi, which was very much discussed in the thirteenth century both at Paris and at Oxford. The account of it by M. Doublet similarly misses the most important part of the system. In the same way, the account of King Alfonso and his Tables reproduces all the old misstatements which have been refuted long ago. The tables were *not* published at the time of the King's accession, but some twenty years later, and *no* change was made in them as regards precession; they were *not* prepared by a "numerous commission," for it would have been necessary to raise the dead, since the alleged members of that Royal Commission lived long before King Alfonso's time. The "Libros del Saber" were never translated into Latin, and were quite unknown until they were at last printed some sixty years ago, and the last edition of the tables was not printed then, but in 1641.

The author's account of the progress of astronomy from the end of the Middle Ages to the time of Newton does not differ much in extent or quality from the earlier chapters. We have only space to direct attention to a misunderstanding on p. 255, with regard to Kepler's work on Mars. What produced errors of 8' was not the use of the Tycho system (for that, of course, made no difference whatever, being merely the Copernican system with the origin of co-ordinates transferred to the earth), but the use of an eccentric circle with "bisected eccentricity," after the manner of Ptolemy.

Having found the first two-thirds of the book rather disappointing, we are glad to say that the chapters on French astronomers in the eighteenth and first half of the nineteenth century are very interesting and pleasant to read. They do not go into details as to the work of these astronomers, any more than do the earlier chapters, but they tell a good deal about the Cassinis, the Maraldis, etc., down to Arago and Leverrier, which will be new to most readers.

J. L. E. D.

### Our Bookshelf.

*How to Measure in Education.* By Prof. W. A. McCall. Pp. xiii + 416. (New York: The Macmillan Co.; London: Macmillan and Co., Ltd., 1922.) 15s. net.

IN the work under notice an attempt is made to show that everything in education must submit to statistical measurement or be condemned as worthless. Fourteen theses in praise of measurement are blazoned in large type at the outset. One of them states, "To the extent that any goal of education is intangible it is worthless"; as this is given not only the dignity of capitals but also the embellishment of inverted commas it presumably conveys some meaning to the author. Education in this book means a few of the elements of instruction, such as reading, writing, and the mechanical parts of arithmetic and composition. An elaborate analysis is given of how to diagnose defects in reading, and ignoring the analysis, we are told that "there are more failures due to failure of interest than the world dreams of." The schoolmaster who has important tasks in education other than those of teaching mechanical elements would greatly value some help in measuring the interest of his pupils, but will ask in vain. The importance of carefully framed instructions in giving tests is rightly stressed, but we are told that such "instructions should equalize interest." To accomplish this the pupil must, apparently, be told how important it is to do well in a test. If he is refractory, or keen on other things in school besides tests, the advice may not be effective. Masters, however, are in a worse plight, for the tests are used not only to measure the pupils, but also the teaching and the teachers; and that form of measurement is said to be of most service "which does not require a previous acquaintance with the pupils."

The most valuable part of the book is that concerned with "scaling the test," as it shows the large amount of statistical treatment necessary to prepare a suitable test of skill. A useful suggestion is made for fixing a single common unit of measurement for all mental scales for elementary schools, namely, some function of the variability of pupils of twelve years. The standard deviation of pupils of sixteen years is also suggested as a unit for measuring older scholars.

The final section of the book deals with tabular, graphic, and statistical devices. Each part has a useful students' bibliography, but it is strange to note the omission, in a work of this nature, of all reference to the writings of Udney Yule, from whom the student of statistical methods will derive more real help than from any of the authors quoted.

*Fruit Farming: Practical and Scientific for Commercial Fruit Growers and Others.* By C. H. Hooper. Second edition, Revised and Extended. Pp. xxiii + 212. (London: The Lockwood Press, 1921.) 6s. net.

WITHIN the limits of two hundred pages Mr. Hooper has aimed at the production of a text-book of fruit farming under English conditions. After a brief introductory section on the training of the prospective grower, he deals in succession with the capital required, the selection of suitable land, the law in relation to fruit farms and market gardens, the laying-out of

plantations and orchards, and the cultural details and costings of the more important hardy fruits of this country. The later chapters are concerned largely with the more scientific aspects of the subject, such matters as soils, manuring, insect and fungoid pests, and spraying and other forms of disease-control in turn receiving attention. Also included are brief histories of many of the well-known varieties of apples, pears, plums, and cherries. The numerous interesting and economically important problems relating to pollination and fertilisation and the setting of fruit are briefly considered and the author is able here to provide data from his own investigations. The volume is completed by several sections dealing with special points of a purely commercial character, as, for example, the marketing of fruit and book-keeping.

Many chapters have been contributed by specialists and present in an abbreviated form the results of recent research. A large part of the volume has in fact been re-written since the first edition and brought up-to-date. With these alterations and some useful additions the second edition justifies its appearance.

In a work of so small a compass, which seeks to stand as a text-book of its subject, the selection of matter for inclusion calls for careful discrimination. It is open to some criticism in this respect and also for occasional repetition. Printers' errors are not infrequent in certain chapters. Much of the information given on economic points is not readily accessible elsewhere, and it is in this direction probably that the volume will prove to be of most service to its readers.

*First Lessons in Practical Biology.* By E. W. Shann. Pp. xv + 256. (London: G. Bell and Sons, Ltd., 1922.) 5s.

MR. SHANN'S endeavour to provide a course of biology suitable for lower fifth forms, and within the means of the average school, is not entirely satisfying. Rightly he relies on plants for the experimental work, and on both plants and animals, employing them in alternate chapters, for the observational. But experiments on plant physiology are not reached until chapters 16 and 17; and by that time the preceding lessons have incidentally given the very information which the experiments should surely be intended to enable the pupils to discover for themselves. There are good chapters on variation and heredity, soils, insect pests, and other topics of general biological interest; but neither with plants nor with animals does the author make the best use of his material as a means of education and of training the powers of observation and reasoning. If he disapproves of the heuristic method, he should at any rate indicate the evidence on which conclusions as to homologies are based, and not be content with mere statements.

Apart from general considerations, sentences are in several instances faultily composed; and there is a large number of actual errors: e.g. "false" fruits are wrongly defined; rose-hips will germinate without passing through the digestive tract of an animal; rose stamens are peri-, and not epigynous; *Urtica urens* has not a creeping stem; the biramous appendage is not the primitive form of crustacean appendage; the telson is not a segment; the abdomen of Blowfly does not exhibit respiratory movements; the embryo in a

seed is not simply the plumule and radicle, but includes also the cotyledons—we have not exhausted the list of inaccuracies.

Many of the illustrations are the work of boys at Oundle School and are of creditable draughtsmanship; but for teaching purposes we prefer outline with a minimum of shading in order that significant features may receive due emphasis.

*The Discovery of the Circulation of the Blood.* By Dr. Charles Singer. (Classics of Scientific Method.) Pp. x+80. (London: G. Bell and Sons, Ltd., 1922.) 1s. 6d. net.

THIS is the first of a new series entitled "Classics of Scientific Method," and whets our appetite for its successors. The series aims at providing in convenient form reproductions of the great masterpieces of science, together with an account of the action and re-action of ideas which, through process of time, led up to the crucial experiments carried out and described by some great master. This account of Harvey's discovery of the circulation of the blood is excellent. The first chapter, in language freed so far as is possible of technical terms, describes the structure and function of the circulatory system as we now know it—a modification of the paragraph on p. 8 dealing with the relation of carbon dioxide and hæmoglobin seems desirable—and contains a clear diagram. The subsequent chapters set forth in words and by illustrations the ideas held by the ancients regarding the vascular system, and how the Renaissance of the fifteenth century and the work of such men as Leonardo da Vinci, Servetus, and others, culminated in Harvey's great discovery, of which a detailed and most interesting account is given.

*Laboratory Exercises in Inorganic Chemistry.* By Prof. J. F. Norris and Prof. K. L. Mark. (International Chemical Series.) Pp. x+548 (every second page blank). (London: McGraw-Hill Publishing Co., Ltd., 1922.) 10s. net.

THE first question which must be considered in connexion with a book of this kind is the class of students for whom it is intended. The preface indicates that it contains a first year's course for students who have had "a good training in chemistry in the high school." It is unsuitable for such students in England, as many of the experiments would already have been done at school, and many of the remainder would be regarded as too difficult for intermediate students. The "International" character of the book is therefore open to question. Although the book is not suitable as a students' manual in English colleges, it should be very useful in suggesting experiments to teachers, both for lectures and for laboratory work. Many of the directions are given in unnecessary detail for students of average intelligence: how to light a Bunsen burner, for example, and there is a good deal of repetition. The blank pages are included in the pagination.

*A Text-book of Organic Chemistry.* By Dr. A. Bernthsen. New edition, revised to date, by Prof. J. J. Sudborough. Pp. xvi+908. (London and Glasgow: Blackie and Son, Ltd., 1922.) 12s. 6d. net.

BERTHSEN'S text-book, in its English translation, has proved of great value to students. It is therefore satisfactory to note that the new English edition has

been carefully revised and large sections dealing with important recent advances in the science added, as well as numerous small supplementary paragraphs in the old text. For a book of this character the minor errors noted are surprisingly few, and are obvious to the reader. One important omission may be noted: on p. 78 it is stated that methyl alcohol "acts as an intoxicant like ethyl alcohol," without a word as to the very deleterious physiological action of methyl alcohol. The printing and get-up are excellent, but the binding is too weak for students' use. The moderate price of the book, as well as the clear and accurate character of its contents, will ensure its continued popularity among students. The very full references to physical properties make it also a handy book of reference in the laboratory.

*Plumbers' Handbook.* By Samuel Edward Dibble. Pp. ix+629. (New York and London: McGraw-Hill Book Co., Inc., 1922.) 20s.

THE author of this handbook has had the co-operation of several well-known American professional men, and the result is a very valuable compendium relating to plumbing, sanitary arrangements, gas-fitting, heating, etc. The book is equally suitable for the practical man engaged in carrying out schemes, and the student who is learning his business. Of special interest to the British reader is Section 14, dealing with codes, or byelaws, as we should call them. These are extremely suggestive, and if carried out systematically in the United States will excite the envy of many British workers who have still to endure primitive sanitary conveniences. There is so much of value in this section that it is impossible to quote any of the points in a short review.

Science is not neglected in this volume, and there are sections dealing with metallurgy and chemistry. There is also a section on elementary mathematics; we think that the arithmetical rule for cube root (p. 511) might have been omitted, especially as logarithms are dealt with on pp. 508 and 509. The book can be strongly recommended to all connected with sanitation.

*Diptera Danica: Genera and Species of Flies hitherto found in Denmark.* By William Lundbeck. Part VI. *Pipunculidæ and Phoridae.* Pp. 447+137 text-figs. and index. (Copenhagen: G. E. C. Gad; London: Wheldon and Wesley, Ltd., 1922.)

ALL students of the order Diptera will welcome the continuance of this wholly admirable treatise. It is a model of what a faunistic work should be and, unlike so many volumes of a similar nature, it also includes a useful summary of existing knowledge of the metamorphoses and habits of the insects with which it deals. The author has also wisely added the dates of capture of the various species: elementary facts of this kind are so often omitted from faunistic works that the reader is usually left with no idea as to when a particular species is likely to be met with. Of the two families dealt with in the volume before us, the Pipunculidæ include 25 Danish species out of about 75 palæartic representatives, and the Phoridae include 210 Danish species out of a total of about 335 from the whole of Europe. The work is well printed, clearly illustrated, and written in excellent English.

### Letters to the Editor.

[The Editor does not hold himself responsible for opinions expressed by his correspondents. Neither can he undertake to return, or to correspond with the writers of, rejected manuscripts intended for this or any other part of NATURE. No notice is taken of anonymous communications.]

#### Action of Cutting Tools.

PROF. F. G. COKER has been good enough to send me a copy of his paper on the above subject, together with the discussion which followed its reading before the Institution of Mechanical Engineers. I will (with your permission) take this opportunity of thanking him and of adding a few remarks to my letter to NATURE of August 26 of this year.

I had not, when that letter was written, a copy of the Proc. R.S. paper of 1881 at hand, and was not certain as to how far the experimental processes

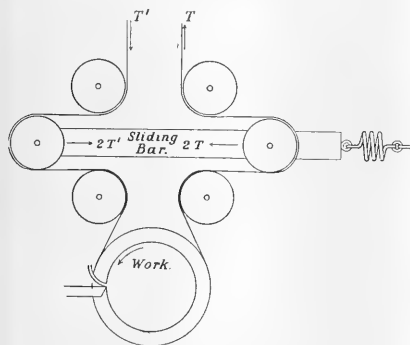

FIG. 1.—Diagrammatic sketch to show the action of dynamometer used for measuring the force on tool,  $T$  and  $T'$  being the tensions of the two parts of the driving belt. The force acting on the sliding bar is  $2(T - T')$ . This is balanced by the extension of the spring. Hence the movement of the bar, in conjunction with the known diameter of the work, gives (when corrected for the friction of the pulley, etc.) a measure of the force acting on the tool.

preceding its production were described. On re-reading, however, I see that the experimental part was omitted, and I may here state that the force on the tool was measured by a dynamometer of the type shown diagrammatically in Fig. 1, and that it was found that for cuts of similar section the force required was very nearly proportional to the cross-section of the strip removed. This of course is equivalent to the statement that the same amount of work will remove the same volume of material whether the shavings are thick or thin, provided that they are similar.

This dynamometer, which recorded the force automatically on paper moving with a velocity proportional to that of the cut, worked satisfactorily when the cutting speed was suitably chosen, though I should not use the same pattern were I again to embark on such investigations.

The materials on which the experiments were made included, besides the ordinary metals, others easier to deal with in a lathe worked by foot, and of these clay was found to be the most useful, for, according to the state of dryness to which it was brought, its behaviour under the action of the tool could be made to resemble that of any sort of metal, hard or soft, and at the same time cuts of easily

measurable thickness could be taken with comparatively small forces.

While referring to the subject of material, I may mention a matter which seemed to me rather surprising. I wished to see whether it would be possible to face up a speculum casting in the lathe in order to save time in the preliminary grinding. Speculum metal, as is well known, is very brittle, but by taking a broad cut of extreme thinness with a dead-hard steel tool, continuous shavings were produced which looked like ribbons of grey satin. It was only while the edge of the tool was perfect that the cut was satisfactory, and this condition rarely lasted long enough to cover a speculum two inches in diameter.

With regard to Prof. Coker's paper, the only objection I have to make is that it has no reference to the action of cutting tools. The polarised-interference bands are evidence of elastic strain. They might be maintained indefinitely when the tool was stationary if the applied force was just insufficient to produce further rupture, and would disappear when that force was removed.

The elastic deformation, though interesting, has nothing to do with the special action of the tool, the essential function of which is to cause destructive strain throughout a small region near its edge while having no permanent effect on the body of the work.

The real interest in the action of a cutting tool is confined to the plane AB (Fig. 2) along which destructive shear takes place and a very short length of the material which forms the shaving—together with that part of the tool in contact with it.

The internal structure of a shaving closely resembles that of slate, the principal plane of cleavage being parallel to AB of Fig. 2, and the angle which this plane makes with the direction of the cut is modified

by, and may be said to depend on, the angle which the face of the tool makes with the same direction and the mutual coefficient of friction between the tool and the material on which it operates.

The action of the tool is always discontinuous and quasi-periodic, the period being determined by the travel required to extend the destructive shear from A to B. The period, therefore, is proportional (among other things) to the depth of the cut.

From this it may be seen that, in addition to the principal planes of cleavage, secondary and slightly differently inclined cleavages occur before the shearing across AB is complete. This was well shown in the polished and etched sections<sup>1</sup> referred to in the 1881 paper, and can also be recognised in the accompanying photographs (Figs. 3 and 4), though not quite so clearly.

The normal force on the tool during each period tends to expand (like rivet heads) the base of the strata which press against it, and this action causes the shaving to curl: the frictional force (parallel to the face of the tool) tends, on the other hand, to drag the base of strata towards the cutting edge, and thus to keep the shaving straight.

The shape of the cross-sections of a shaving is often rather peculiar, but is a definite function of the shape of the tool and of the properties of the material from

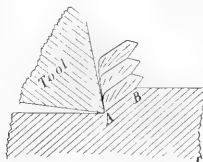

FIG. 2.—Action of a cutting tool, showing the principal and secondary planes of cleavage.

<sup>1</sup> The earliest application of "etching" for the purpose of rendering the structure of a metal visible was, I suppose, the "crowning" of twisted gun-barrils, etc.

which it is cut. It may be defined shortly as the projection on the plane of the section of the line bounding the area of destructive shear. This line will be in advance of the face of the tool by a distance



FIG. 3.

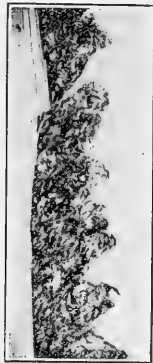

FIG. 4.

FIG. 3.—Shaving from a block of paraffin. At the temperature at which the cut took place, the paraffin behaves much like a sample of cast iron.

FIG. 4.—Longitudinal section of a similar shaving. The paraffin shaving was embedded in soap, sectioned in a microtome, and mounted in castor oil.

proportional to the thickness of the cut at the point under consideration (see Fig. 5).

The shaving is always shorter than the length of the cut from which it was taken, and if  $\alpha$  and  $\beta$  are respectively the angles which the principal plane of cleavage and the face of the tool make with the normal to the surface of the cut, it is easy to see that the ratio of the lengths is  $\cos \alpha / \sin (\alpha + \beta)$ .

Lubrication has an extraordinary effect in the cutting of certain materials. With brass and gun-metals no lubrication is required, but for steel, and also for such metals as soft copper and pure aluminium, clean cutting is impossible without it. Glass cutting with steel tools also requires a lubricant, for which purpose turpentine or petroleum are generally chosen.

I remember, in a correspondence with Sir G. G. Stokes on this subject, mentioning that even the presence of turpentine vapour had a noticeable effect. There can, I think, be little doubt that films of lubricant (of molecular thickness it may be) pass not only over the active part of the tool, but also penetrate along the planes of cleavage in the shaving itself.

A. MALLOCK.

9 Baring Crescent, Exeter.

#### One Possible Cause for Atmospheric Electric Phenomena: A Reply.

IF Sir Oliver Lodge will turn up his copy of NATURE for January 21, 1904 (Vol. 69, p. 270), he will find that I made there the identical suggestion for the origin of the earth's negative charge which he makes in NATURE of October 14, p. 512. The explanation

is, however, unsatisfactory for a number of reasons, the chief of which may be stated shortly as follows:

To maintain the current from the earth into the atmosphere, it would be necessary for 2000 negative electrons to be shot into each square centimetre of the earth's surface every second. But beta rays ionise the air through which they pass, and according to recent theoretical work it appears that beta rays, no matter what their velocity may be, produce more than 40 pairs of ions along each centimetre of their path in air at atmospheric pressure. Thus in each cubic centimetre of air near the earth's surface 80,000 pairs of ions would be produced per second. But we know from actual measurements extending from the equator to the polar regions that only 4 or 5 are so produced and all these can be accounted for by known radiations.

Sir Oliver suggests that "the beta particles would be magnetically inveigled towards the poles, where they might descend with down currents." This suggestion has been made previously, and it is easy to show that it offers no way out of the difficulty although the demonstration is too long to be given here.

G. C. SIMPSON.

October 17.

#### The Green Ray at Sunset and Sunrise.

IN NATURE of October 14, p. 513, Prof. Alfred Porter maintains that there are two distinct phenomena which go under the name of the green flash, and that the one most usually seen is an after image in an eye fatigued by the red light of the sun. I have seen the green ray many times in this country and in the tropics, and the phenomenon as I have seen it is always exactly the same; I am quite convinced in my own mind that it is not due to eye fatigue, for the appearance at sunrise is precisely the same as that at sunset; I have seen it a number of times at sunrise, and the first time I ever saw it was at sunrise when I was not looking out for it. I have, moreover, examined the setting sun with binoculars and with a telescope; when the sun has very nearly set, but before the appearance of the green ray proper, the upper edge has a very irregular shape owing to refraction effects, sometimes resembling flames; the tops of these "flames" gradually become bright green and the colour spreads downwards till the whole of the minute remaining part of the disc becomes green. To any one who has examined the green ray with a telescope at sunset, and has seen it with the naked eye at sunrise, it seems inconceivable that it can be due to eye fatigue.

C. J. P. CAVE.

Stoner Hill, Petersfield,

October 21.

As the green segment continues to be debated, permit me to put a few facts on record. I have often in Egypt watched the sunrise light descending the western hills, and when the edge of the shadow reached me, turned to view the sun. The first appearance of the sun is a blue segment, changing to green, and then to white. This is exactly the converse of the colours of the sunset segment; as the rising light cannot be due to an after-image, no more is the setting light. Moreover I have never seen the green light shift about, as an after-image does, by movement of the eye; it is always exactly on the segment.

Further, I often have protracted the sunset blue by walking up a slope, and so keeping it in view, on and off, as long as I go upward. The least distance



of horizon that is effective is about two miles, at which the change of colour is just visible. The "second phenomenon" of Prof. Porter is the only one which I have seen with open eyes.

W. M. FLINDERS PETRIE.

**A Broadcast "Rainbow."**

ON Friday, September 16, I witnessed an atmospheric phenomenon sufficiently unusual, I believe, to merit a record. Standing on Ogmor Down near Bridgend in this county (Glamorgan) at 2.30 P.M. and looking northwards across the broad vale towards the Maesteg hills, there appeared to me a broadcast rainbow colouring, stretching east and west for several miles along the vale. The day was exceptionally fine, with brilliant visibility and no trace of mist. The clouds were small and scattered, with a distant bank of cumulus beyond the hills, while the colours were clear and unmistakable, covering, from red in the west to blue in the east, an angle of about fifty degrees. The height of my point of view was about 300 ft. above the sea, and the whole apparition hung, like a veil of pure, immaterial colour, at about the level of my eyes, covering the distant hills but without screening their smallest particular. R. C. McLEAN.

The Botanical Department,  
University College,  
Cardiff, September 19.

**Colour Observations of the Moon.**

I WISH to place on record a few observations I have made of the lunar surface seen through colour filters, which point to the presence of coloured light of various shades reflected from different parts of the moon.

The light values of various points of the moon's surface were fixed by means of a photometer shaded by colour-screens, corresponding to similar screens fixed to the eye-piece of the telescope.

Owing to the two different sources of light, electric light in one case and the lunar rays in the other, and also owing to atmospheric changes, the two sets of filters had to vary considerably in colour, in order to produce the identical colour impression on the eye.

For the telescopic eye-piece I used the following colour screens throughout these observations:

- 1. Red of approx. 6563 "Tenth-metre" wave-length (absorbing practically all but red rays and a little yellow).
- 2. Green " 5173 wave-length (absorbing all but green and blue rays).
- 3. Violet " 4420 wave-length (only absorbing yellow rays).

For the photometer I used varying colours (according to atmospheric conditions), averaging

1a	of approx. 6120 wave-length.
2a	" 4922 "
3a	" 4550 "

The area examined was the vicinity of Clavius. I determined the light value of the brightest spot in the neighbourhood (A) through the three screens, and in the same way a number of other spots; B, the eastern inside wall of Clavius; C and D, the floor of the crater plain; E, the great valley to the west of Clavius; F, the southern slopes of Maginus.

The result of the two observations, No. I. on August 31, No. II. on October 1, 1922, was as follows,

reducing the figures to percentages, the brightest spot (A) being taken as 100 per cent. in each case:

	A.	B.	C.	D.	E.	F.	
Red screen	100%	I. 46.0 II. 9.1	I. 1.2 II. 0.66	I. 3.6 II. 0.85	I. 10.0 II. 2.2	I. 15.7 II. 9.1	% %
Green screen	100%	I. 4.2 II. 22.2	I. 0.7 II. 0.3	I. 1.3 II. 0.46	I. 14.0 II. 2.5	I. 49.0 II. 22.2	% %
Violet screen	100%	I. 30.0 II. 5.4	I. 3.3 II. 1.7	I. 8.4 II. 2.0	I. 15.0 II. 2.8	I. 21.4 II. 5.4	% %

In examining the above list it will be noticed that there is a discrepancy regarding the point B, which may be due to the dazzling brilliancy of this area during the first observation. All the remaining figures, however, agree remarkably well, considering the extreme simplicity of the instruments I employed.

The experiments tend to show that (1) the floor of Clavius (also of Longomontanus, which I observed on October 1) is of a mauve colour. These areas may be basaltic and not unlike some Hawaiian crater plains of solid lavas. (2) The Terra Photographica to the west of Clavius has most probably a mottled surface of brown areas on a blue background such as copper sulphate. (3) The southern slopes of Maginus are intense green, probably streaked with areas of the same substance and colour of the crater valleys recorded.

It would be of great interest to survey accurately in this manner districts such as the crater Linné. Later tests would then clearly show if any change could be recorded in these debated areas, at least so far as coloration is concerned. A. F. WARTH.

109 Sandford Road,  
Moseley, Birmingham.

**The Local Handbook of the British Association.**

IN NATURE of October 21, p. 539, a reviewer states that "the ideal handbook in connexion with the annual visits of the British Association has yet to be written." A Committee of the Association might well be appointed to draw up a scheme. Meanwhile, I venture to offer the following suggestions:

- 1. The book should above all be portable, and for this purpose it should be divided into separate pamphlets, each tucked under a separate tape in a cloth-covered binding, common to the series. One could then select one's pamphlet and leave the rest in one's hotel.
  - 2. Every handbook should have a complete index for facilitating rapid consultation.
  - 3. There should be a map of the district on the half-inch or quarter-inch scale.
  - 4. There should be a geological map.
  - 5. The compilers should take a lesson from Baedeker and give practical details: population, railway stations, hotels, cab-fares, post office; short list of the chief features—museums, art galleries, libraries, churches of architectural interest, and other guide-book information—in two or three pages, with street in which situated, times of opening, etc., with an asterisk indicating the most noteworthy.
  - 6. Unless the handbook can be sent by post in advance to members (they might pay the postage) it is of little use writing long-winded articles, as visitors—attending sections in the morning, scientific excursions in the afternoon, and addresses in the evening—have no time to read them. BERNARD HOBSON.
- Thornton, Hallamgate Road, Sheffield,  
October 20.

The Early History of the Land Flora.<sup>1</sup>

By Dr. D. H. SCOTT, F.R.S.

I.

IN these articles the "Early History" of the land flora is understood to cover the Devonian and Lower Carboniferous periods. Before the beginning of the Devonian the records of land plants are too scanty and doubtful to demand much consideration; on the other hand, the flora of the Upper Carboniferous is so rich and so well known that to include it would unduly extend the limits of this brief survey.

Concerning the question of the beginnings of a land flora, the position has wholly changed of late, owing chiefly to the Rhynie discoveries. A few years ago we had no clear knowledge of any early Devonian plants, and such imperfect data as we possessed were commonly ignored or discredited. Nothing definite was known of any really simple fossil land-plants; it could even be asserted that the Devonian plants, though different in many ways from those of the present day, were about on the same general level of organisation.

Now we have learnt, from the Rhynie investigations, that, in the earlier Devonian flora, plants existed of quite surprising simplicity, with a mere thallus, leafless and rootless, like that of some very ordinary seaweed, but yet vascular in structure, and obviously adapted to sub-aerial conditions.

The crude simplicity of some of the Rhynie plants even suggested the question whether we might not at last be on the track of the original transmitters from the sea, of those Thalassiophyta whose conquest of the land has been so vividly pictured by Dr. Church.<sup>2</sup> No doubt, the Devonian period was altogether too late for the transmigration he describes, but still some of the plants then living might have retained trans-migrant characters.

The Rhynie fossils are now fairly well known to the botanical reader, and it is perhaps less necessary to insist on their importance than to suggest a warning that we may possibly expect too much from them.

The flora is extremely limited and local; our knowledge of the plants, owing to the unsurpassed skill and judgment with which they have been worked out by Dr. Kidston and Prof. Lang,<sup>3</sup> is exceptionally perfect, but there are very few of them and they are all from one old peat-bed.

We may shortly recapitulate the leading facts. The Rhynie species of vascular plants are four in number: *Rhynia Gwynne-Vaughani*, *R. major*, *Hornea Lignieri*, and *Asteroxylon Mackiei*. *Rhynia* and *Hornea* constitute the family Rhyniaceæ, remarkable for its extreme simplicity of structure; *Asteroxylon* is a much higher plant, and is placed in a distinct family.

Both the Rhynias are rootless and leafless plants, with a branched underground rhizome, and a vertical aerial stem, also branched; the whole plant was eight inches or more in height. On the rhizome there are absorbent hairs, while the aerial stem possesses a few perfectly typical stomata. Otherwise there is little

differentiation between the subterranean and sub-aerial parts. The whole may be called, without hesitation, a thallus. Both stem and rhizome are traversed by an extremely simple vascular strand.

*Rhynia major* is considerably the largest plant of the two, but *R. Gwynne-Vaughani* is somewhat the more differentiated, for its aerial stem is studded with hemispherical outgrowths, from which, in some cases, additional branches arose, and often became detached, serving no doubt as a means of propagation. Both outgrowths and adventitious branches are absent from *R. major*, where the stem is merely forked.

It was at one time supposed that the outgrowths of *R. Gwynne-Vaughani* might represent very rudimentary leaves, but later observations have shown that they were developed late in life, usually in connexion with the stomata, and thus formed no part of the original equipment of the plant. They may even have been traumatic in origin.

The reproductive organs are spore-sacs (sporangia) borne on the ends of branches. In *R. major* the sporangia are large—nearly half an inch long; they have a fairly complicated wall, and are filled with well-preserved spores, often still grouped in fours, and in all respects like those of the Higher Cryptogams now living.

The second genus, *Hornea*, has a tuberous rhizome comparable to the protocorm often found in young Club-mosses, but the stem is like that of *Rhynia major*, on a smaller scale, and just as simple. The sporangia are the most remarkable feature; they are terminal on the branches, as in *Rhynia*, but in *Hornea* each spore-sac has a central column of sterile tissue (the columella), over-arched by the spore-bearing layer, exactly as in the capsule of the Bog-Moss, *Sphagnum*, at the present day. This moss-like feature is very suggestive and has given rise to a good deal of speculation. Another peculiarity of the spore-sac is that its walls are scarcely differentiated from the ordinary tissues of the branch, and that where the branch forks the sporangium forks too. Here, then, it is evident that the sporangium is not an organ *sui generis*, as modern botanists have generally taught, but just the end of a branch, set apart for spore-production.

The *Sphagnum*-like structure of the spore-sac in *Hornea* is not without analogy, for just before the Rhynie discoveries, Halle had described, from the Lower Devonian of Norway, a fossil which he named *Sporogonites*. This is remarkably like the stalked capsule of a Moss in external appearance, and internally (though imperfectly preserved) it proved to have a columella of the same form as that subsequently observed in *Hornea*. Thus the Rhyniaceæ are not only the simplest vascular plants known; they likewise suggest analogies with the Bryophytes. They have in fact been placed by different botanists in three different sub-kingsdoms: in the Pteridophytes, the Thallophytes, and the Bryophytes, on grounds which will be evident from the facts already given. Possibly they may represent a basal group, related at once to the Vascular Cryptogams and the Moss phylum, while at the same time retaining some of the old characters of an Algal stock. But we cannot regard so interesting

<sup>1</sup> Based on a course of lectures given last spring at University College (University of London).

<sup>2</sup> A. H. Church, "The Thalassiophyta and the Sub-aerial Transmigration," *Oxford Botanical Memoirs*, III, 1919.

<sup>3</sup> Kidston and Lang, "On Old Red Sandstone Plants, showing Structure, from the Rhynie Chert-bed, Aberdeenshire," *Transactions of the Royal Soc. of Edinburgh*, Part I., vol. 51, 1917; Parts II. and III., vol. 52, 1920; Parts IV. and V., vol. 52, 1921.

a conclusion as established until we are satisfied that the surprisingly simple organisation of the Rhyniaceæ was really primitive.

We can scarcely feel sure that a certain amount of reduction may not have already been undergone, even by this early race of land-plants. The presence of stomata of the familiar type proves that the plants must long have been adapted to a sub-aerial life; at the same time the small number of these organs suggests xerophytic modification, which is quite consistent with a peat-habitat. In fact the habitat warns us that the Rhynie plants may not have been quite typical representatives of the flora of their time. A comparison with the Saltwort (*Salicornia*) of our mud-flats has even been suggested! Such a plant, however, bears obvious marks of reduction which are wanting in the Rhyniaceæ.

We can do no more than leave the question open. Probably we are justified in accepting Rhynia and *Hornea* as members of a relatively primitive race, even though their excessive simplicity may have been in some part due to the peculiar conditions under which they had to live.

The presence of *Asteroxylon* in the same beds might perhaps be taken as an argument against the theory of reduction, for *Asteroxylon* was, comparatively speaking, a highly organised plant. It is true it had no roots, but the branched aerial stem was well clothed with leaves, and had very much the habit of a Club-Moss (*Lycopodium*). The anatomy of the stem was also quite complex compared with that of the Rhyniaceæ, though the rhizome was as simple as theirs, and, oddly enough, bore no hairs. *Asteroxylon* was a larger plant than the others, and had nothing specially primitive in its external aspect. The leaves were peculiar, however, in having a very imperfect vascular supply, for the strand which ran out from the central stele towards each leaf stopped short in the leaf-base and never entered the blade. This is one of three points which suggest a certain degree of possibly primitive simplicity, the other two being the absence of differentiated roots and the structure of the water-conducting elements (tracheides). Though the wood is well developed and rather complex in form, having a stellate transverse section, all the tracheides are of one kind, namely, spiral.

Unfortunately, our knowledge of *Asteroxylon* is not quite so satisfactory as in the previous cases, for the fructification has never been found in connexion with the plant. There are peculiar naked branches closely associated with a few of the specimens, and with these branches, again, sporangia are found in association. The sporangia are quite different from those of the Rhyniaceæ, but recall the fructification of some of the Carboniferous ferns. If we assume that the naked branches and the sporangia belonged to the *Asteroxylon* we get a very remarkable combination of characters, as pointed out by Kidston and Lang. While the anatomy and morphology of the vegetative organs are suggestive of Psilotaceæ (a small tropical and sub-tropical family, of uncertain affinities) and Lycopods, the supposed fertile branches and sporangia would link the plant to the ferns. We cannot, however, lay much stress on this surprising synthesis of diverse characters until the connexion of the parts has been

established. At present there is no evidence beyond intimate association.

Kidston and Lang are inclined to identify *Asteroxylon* with *Thursophyton*, a Middle Devonian plant, of Club-Moss-like habit, hitherto only known from impressions. The fructification assigned by certain writers to species of *Thursophyton* is, however, of a Lycopodiaceous character, and totally different from that attributed to *Asteroxylon*.

*Asteroxylon* is included, together with the Rhyniaceæ, in the class Psilophytales, established in the 'fifties of the last century, is the type. There is now no doubt that Dawson's account of *Psilophyton*, so long discredited, was substantially correct. The plant had a branched rhizome and a forked upright stem, more or less spiny. The fructification consisted of long terminal spore-sacs, much like those of Rhynia. The morphological nature of the spines is disputed; they may be interpreted as rudimentary leaves or as mere out-growths, like those of *Rhynia Gwynne-Vaughani*. A general affinity between Dawson's plant and the Rhynie fossils is evident, but the exact relations remain doubtful. The late Dr. Arber regarded *Psilophyton* as identical with Rhynia; Kidston and Lang, on the other hand, have decided to place it in the same family with *Asteroxylon*. Neither view is established.

It may be mentioned that a possible *Psilophyton* has recently been recorded by Prof. Halle from the Silurian (Lower Ludlow) of Gothland, an interesting discovery, if confirmed.

Many plants besides the four species of *Vasculares* were found at Rhynie. The most interesting is a specimen of *Nematophycus* (or *Nematophyton*), a genus hitherto generally regarded as belonging to the Algæ; it has a complex structure of interwoven filaments, and some of the species, from other localities, attained a gigantic size. It is very remarkable that a plant with the structure of a highly organised seaweed should occur in a purely terrestrial flora like that of the Rhynie chert-bed. It may suggest that the Algæ of the period were doing a little transmigration on their own account.

A number of genera of the early Devonian flora have been recorded as impressions, showing little or nothing of the internal structure. Space forbids our describing them here. Some are much like *Psilophyton*, others resemble Club-mosses, while others again have a curiously Alga-like habit. An excellent summary of our knowledge of the Devonian plants generally will be found in Dr. Arber's little volume.<sup>4</sup>

The earlier (Lower and Middle) Devonian flora was for the most part characterised by comparatively simple types of land plants; in some cases, as we have seen, their simplicity was extreme. Even then, however, there is evidence that very much higher forms existed. Thus the fossil known as *Palæopitys Milleri*, from the Middle Old Red Sandstone of Cromarty, was described by its discoverer, Hugh Miller, as a "Coniferous tree," and really has the structure of a well-organised Gymnosperm. Miller himself fully realised the importance of his discovery, which has scarcely received the attention from botanists which it deserves.<sup>5</sup>

(To be continued.)

<sup>4</sup> E. A. N. Arber, "Devonian Floras, a Study of the Origin of Cormo-phyta," Cambridge University Press, 1921.

<sup>5</sup> Hugh Miller, "Footprints of the Creator," edition of 1861, p. 191.

Solar Radiation and its Changes.<sup>1</sup>

WHEN one reflects upon the wide knowledge gained by astronomers concerning stellar and nebular radiation and variability, it at first seems surprising that variation in the visible radiation emitted by the sun has been discovered only recently and with much difficulty. Not until the second decade of this century could the fact be regarded as established, as a consequence of simultaneous determinations of the "solar constant" made by the staff of the Astrophysical Observatory of the Smithsonian Institution, at two stations so widely separated as Bassour in Algeria and Mount Wilson in California. The solar constant is, of course, the estimated value of the intensity of total solar radiation, in calories per square centimetre per minute, at a point just outside the earth's atmosphere, *i.e.* before suffering absorption in transmission to the earth's surface.

The main difficulty arises from the necessity of making practically absolute determinations of the solar constant, because the sun's proximity to us renders it sufficiently unique and solitary in the daylight sky to prevent that comparison with many and similar neighbours which is the foundation of our knowledge of stellar variability. No real progress towards such knowledge regarding the sun could be made until it became possible to determine and allow for the radiation absorbed in the earth's atmosphere. Failing this, even long series of simultaneous observations of the changes in the solar radiation, as received at different points on the earth's surface, are of little use, because any features common to two stations may arise from some common terrestrial cause. A striking example of this was recorded by the Smithsonian observers during the fifty days on which observations were made both at Bassour and at Mount Wilson. On June 6, 1912, a great volcanic eruption occurred at Mount Katmai in Alaska; on June 19 the sky became slightly turbid in Bassour, and a day or two later also at Mount Wilson. The milky haze rapidly increased till in July and August a thick haze overspread the whole sky and cut off more than 20 per cent. of the sun's direct radiation at noonday; yet after applying properly determined corrections, normal and accordant values of the solar constant were obtained at Bassour and Mount Wilson during the above period.

The variability discovered in the sun's radiation is of two kinds; irregular variations occur over periods of a few days or weeks, amounting to a small percentage of the whole intensity, while small variations of longer period are found, showing some correlation with the periodicity of sunspot activity. Considering how marked are the changes in solar-spottedness, and in the accompanying magnetic and auroral phenomena upon the earth, it is remarkable how small are the variations in the main solar radiation. Many attempts have been made to connect the sunspot cycle with meteorological changes likely to depend on the solar radiation reaching the earth, but with very doubtful success—the terrestrial factors which share in determining the weather and crops are too complicated, and it now appears that the long-period changes in the solar

radiation are themselves very small. Hence they were bound to remain undetected till direct methods and appropriate instruments were devised which made possible a frontal attack upon the problem. The method which has proved successful is due to S. P. Langley, and the spectro-bolometer which he invented (in 1880) is one of the chief instruments employed; but many improvements and additions both of method and in the instrumental equipment have been since made, and largely by the staff of the Smithsonian observatory under its director Dr. C. G. Abbot.

Langley's method is, briefly, as follows: Absolute measurements of the total solar radiation reaching the earth's surface are made with an instrument (the pyrhelimeter) which indicates the heat energy absorbed by a blackened silver disc exposed to the radiation. It is claimed that the error of a single reading with this instrument is less than 1 per cent., and inter-comparison of pyrhelimeters over periods of several years shows that the scale is free from secular changes exceeding 1 per cent. Such absolute observations are made at frequent intervals during a forenoon or afternoon, with the sun at different altitudes from 15° upwards; the measurements vary on account of the varying absorption as the radiation passes through a greater or lesser length of atmosphere.

The correction for the absorption is obtained with the aid of the spectro-bolometer, which consists essentially of a wire on which radiation of a particular wave-length is directed, after passing through a suitable prism. The resulting rise of temperature in the wire is measured by the change in its electrical resistance, and by passing the whole available spectrum over the wire a "bolograph" showing the energy-intensity curve over the solar spectrum is obtained. Such bolographs, corresponding to different successive altitudes of the sun, show the absorption in all parts of the spectrum during the passage of radiation through lengths of the atmosphere proportional to the secants of the sun's zenith distance; their comparison makes it possible to correct each bolograph for the absorption. In certain regions of the energy-curve where powerful selective absorption occurs by water and other atmospheric vapours, it is assumed that the absorption bands are absent outside the atmosphere, the curve being completed by interpolation between adjacent parts of the curve on either side.

While highly sensitive, the bolograph gives relative rather than absolute measures of solar radiation, and the scale of the uncorrected bolograph is obtained by comparing its area with the value of the total radiation as measured by the pyrhelimeter. The bolograph corrected for absorption then gives the value of the solar constant. It is estimated that the probable error of an ordinary daily determination of the latter is from 0.2 to 0.3 per cent. as regards the relative values from day to day, *i.e.* omitting the probable error of the pyrhelimeter scale value. The whole daily error should therefore be well below 1 per cent. under good conditions, though at times irregular or systematic errors of larger magnitude may occur.

The absolute value of the solar constant, determined from 1244 observations, mainly at Mount Wilson

<sup>1</sup> "Annals of the Astrophysical Observatory of the Smithsonian Institution." Volume IV. By C. G. Abbot, F. E. Fowle, and L. B. Aldrich. Pp. 321+320. (Washington, 1922.)

(1912-20), but also at Calama in Chile (1918-20), is given as 1.946. Dr. Abbot admits, however, a criticism by Kron, to the effect that this value may be 2 per cent. too low owing to a systematic influence tending to magnify the measured atmospheric transmissibility for ultra-violet rays. The error does not affect the evidence for variability in the solar radiation.

The above value is slightly greater than the mean (1.933) for the epoch 1902-12, and it is suggested that the increase is associated with the greater average solar activity during the later period. Whether this be so or not (and the more detailed comparison of values of the solar constant with sunspot numbers scarcely strengthens the evidence for such a connexion), the really remarkable result is the minuteness of the change; the solar agent which affects the diurnal variation of terrestrial magnetism must vary by 20 per cent. or more, instead of  $\frac{1}{2}$  per cent. or 1 per cent., as here. There is, of course, a very slight compensation for any general increase of solar emissivity at times of many sunspots, owing to the diminution of emitting surface caused by the presence of the low-temperature spots; if there are also absorbing vapours above the spots, the compensation may not be merely slight; an appreciable drop (about 5 per cent.) in the solar constant coincided with the passage of a very large group of sunspots across the sun's disc in March 1920.

The short-period "solar-constant" variation, of amount from 2 to 10 per cent., has been further confirmed by simultaneous observations at Mount Wilson and at Calama, Chile; these stations are about 5000 miles apart, on opposite sides of the equator, and at different altitudes. Their observations show a moderate degree of correlation (0.491). Attempts have been made by Dr. Abbot and his colleagues to find connexions between the variations of the solar constant and the variations of contrast of brightness on the sun's disc which have been revealed by observations of the distribution of radiation over the sun's surface. Such measures have been carried on now for more than eight years by the Smithsonian observatory. The association between the two phenomena, if real, is very complex, high contrast sometimes accompanying high, and sometimes low, values of the solar constant. A correspondingly complex theory is propounded to account for this, but a much longer series of observations is required to test the theory. Dr. Abbot urges the desirability of other observatories taking up solar-constant work,

especially in view of the possibility that variations of radiation have predictable meteorological consequences, as Clayton's studies might suggest.

Various other cognate researches have been made by Dr. Abbot and his colleagues, Messrs. Fowle, Aldrich, Moore, and Abbot, during the period, since 1912, dealt with in the volume of *Annals* before us. Variations in the solar radiation have been tentatively sought by observing the changing brightness of the planets. The sun's total radiation has also been measured, at various terrestrial altitudes, from sea-level to high mountain stations, and beyond, up to 25,000 metres, by sounding balloons. A new empirical method of determining the solar constant by observations occupying only fifteen minutes in all has been introduced at Calama; this removes one of the chief sources of error in the longer method, namely, real variations in atmospheric transparency during the observations. In the new method the amount and character of the atmospheric absorption at the time of a pyrheliometer observation is inferred from a measure of the brightness of the sky in a zone  $15^\circ$  from the sun, and from the intensity of a particular water absorption band observed by means of the bolograph. Many observations of the brightness and transmissive power of the atmosphere have been made in the course of this and the other parts of the solar-constant work. Laboratory studies have been made on the absorption of long-wave radiation by water vapour, carbon dioxide, ozone, and by many common solid substances. The reflecting power of clouds has been measured by balloon observations at Mount Wilson in 1918; the ratio of reflection found was 78 per cent., independent of the solar altitude. From this the albedo of the earth is estimated at 43 per cent.

On account of over-frequent cloud and haze at Mount Wilson the solar-constant work carried on there since 1915 has been transferred to Mount Harqua Hala in Arizona, and the Calama station in the plain has been removed to Mount Montezuma, a few miles away. For a short time in 1917-18 observations were made at Hump Mountain in North Carolina, but the situation proved too cloudy. It is interesting to note, however, that one excellent observation was made at a lower air temperature than any experienced elsewhere during a complete solar-constant observation; both the hands and feet of the observer with the pyrheliometer were frozen in the course of the measurements!

## Obituary.

W. H. WESLEY.

WILLIAM HENRY WESLEY, who died on October 17, at the age of eighty-one years, was appointed assistant secretary of the Royal Astronomical Society in 1875, and continued in that office till his death, a period of forty-seven years. He had excellent qualifications for the post, being most orderly and methodical in all secretarial and editorial work, and having great skill as a draughtsman and engraver, as was exemplified in his engravings of Dr. Boeddicker's drawings of the Milky

Way, and the illustrations of the corona in Mr. Ranyard's memoir on solar eclipses. It used to be said that Wesley knew the corona better than any man living, although he had never seen it; however, after an unsuccessful effort in Norway in 1896, the equatorial *coudé* at Algiers was put at his service by M. Trépid in 1900, when he made a detailed drawing in the short duration of totality (64 seconds) and expressed his opinion that the eye was no more efficient than the photographic plate for this work. He made combination drawings from the negatives obtained by the Greenwich staff in the eclipses of 1898,

1900, 1901, 1905, and these will probably be reproduced.

Fellows of the Royal Astronomical Society will long remember Wesley's readiness to help them in their researches, and to put his intimate knowledge of the society's library at their service. He was an original member of the British Astronomical Association, and served as vice-president for many years; on one occasion he delivered the presidential address in place of the late Mr. Green.

A. C. D. CROMMELIN.

PROF. C. MICHIE SMITH.

CHARLES MICHIE SMITH, who died on September 27, was born on July 13, 1854, at Keig, Aberdeen. He studied at Aberdeen and Edinburgh, graduating as B.Sc. in 1876. He was appointed professor of physics at the Christian College, Madras, in the same year, and in 1891 became Government Astronomer at Madras. In 1899 he brought out the New Madras General Catalogue of 5303 stars: the low latitude of Madras gives its star catalogues special importance, since they serve to link the northern and southern catalogues.

Michie Smith observed the annular eclipse of 1894, and the total one of 1898 at Sahdol, obtaining some beautiful large-scale coronal photographs. He also observed the Leonid meteors in 1899, including 37 of the first magnitude (Mon. Not. R.A.S., vol. 60), and published an extensive record of meteors seen at Madras from 1861 to 1890. He also observed the Zodiacal light, and wrote the article on this subject in the "Encyclopædia Britannica" (9th edit.).

Regular meteorological observations were made at Madras, and in 1893, Michie Smith published those of the years 1856 to 1861. He also contributed papers to the Royal Society of Edinburgh on the eruption of Bandaisan, the determination of surface-tension by measurement of ripples, and on atmospheric electricity and the absorption spectra of vegetable colouring matters. It was under his initiative that the mountain observatory at Kodaikanal was inaugurated in 1899, which has played such an important part in the extension of our knowledge of solar physics. He presided over the two observatories from 1899 till his retirement in 1911, when he was succeeded by Mr. Evershed.

WE regret to announce the death of the eminent scholar and editor, Dr. James Hastings, at the age of seventy-one years. The various Dictionaries of the Bible published under his control have enjoyed much popularity, combining with the orthodox position the results of modern criticism. But his greatest work was the "Encyclopædia of Religion and Ethics," the publication of which began in 1908 and ended with the twelfth volume in 1921. Like all works of the kind, it is uneven, but to the student of comparative religion, ethics and philosophy, anthropology and folklore, it is of the highest value. Hastings was a model editor, quiet and unassuming, sparing no pains to verify a fact or a reference; he maintained the most agreeable relations with his many contributors, some of whom must have tried his patience sorely. His fault, if it be a fault, was excessive kindness and hesitation in using his blue pencil when he was dealing with men who were recognised authorities on the subjects which they undertook. The war, which interfered with his arrangements with foreign scholars, added much to his anxieties, and the work must have come to a temporary end if he had not been generously supported by his publishers. He had planned a general index of the Encyclopædia, which will add much to its value for the working scholar. It is to be hoped that the scheme for the index was drawn up before his sudden, untimely, and much regretted death.

In the *Chemiker Zeitung* of September 28 the death is announced on September 15 of Prof. F. Nobbe, of the Forestry Academy of Tharandt, the founder of the research station of plant physiology and the first station for seed control.

WE notice with much regret the announcement of the death on October 26, at sixty-six years of age, of Dr. C. G. Knott, reader in applied mathematics, University of Edinburgh, and on October 28, in his eighty-fifth year, of Prof. A. Crum Brown, emeritus professor of chemistry in the same university.

### Current Topics and Events.

MUCH anxiety is felt in this country as to the position and prospects of the Royal College of Science, Dublin, under the Irish Provisional Government. By a sudden decree, the college was closed on October 1—a day before the new session would have opened. It was announced that a bomb had been found in the building, and this provided a plausible excuse for the action taken. No students had, however, been admitted to the college since June 30, and the circulation of the rumour as to the discovery of the bomb was known to be merely a means of suggesting that the college was a centre of disaffection and that in the interests of public safety it should be closed. For a week or two afterwards the teaching was carried on in buildings lent by the National Uni-

versity, but a second decree was made on October 16 ordering the students, about four hundred in number, to enter the National University classes, an arrangement against which both professors and students strongly protested. A compromise may be effected, but meanwhile the Royal College of Science is in the complete occupation of the military, and no one in authority will say that the building will be restored to its original purposes when military necessity ceases. It would be nothing short of a calamity if an institution in which so much valuable scientific work has been carried on for many years should have its activities abruptly ended to serve purely political purposes. The college is unique in Ireland; its equipment cost more than 250,000l. and no other

institution or university in that country can offer the same facilities for training. It must be heartbreaking to see the practical equipment and apparatus, the fine electric machinery plant, engineering department, and laboratories generally, used for kitchens and bedrooms and at the mercy of military forces unfamiliar with their significance or value. It is almost impossible to get exact information as to the actual position of things in Dublin, but if conditions are half so bad as have been described to us, men of science and scientific institutions should unite to bring them to the notice of their colleagues in other parts of the British Isles and the world of progressive knowledge in general, in the hope that provision for the scientific instruction and research much needed by Ireland will not be curtailed but extended in the near future.

THE Marquess of Crewe has accepted the invitation of the council of the British Science Guild to succeed Lord Montagu of Beaulieu as president of the Guild. Lord Crewe has always taken much interest in the promotion of scientific research, and it was while he was Lord President of the Council in 1915 that the Government scheme for aiding the formation of Industrial Research Associations was announced by him. The British Science Guild is not directly concerned with the methods and results of research in the same way as are the various scientific and technical societies, but with securing adequate facilities not only for extending scientific knowledge itself but also for using it for national progress. Its relation to such societies is similar to that of the Navy League to the navy; and the need of such a body, watching and intervening on behalf of science, and in the interests of administrative efficiency and national development, is as great to-day as ever it was. We understand that the Guild proposes shortly to make a wide appeal for support to extend its activities and to enlighten the general public as to the significance of scientific work and thought in modern civilisation by means of leaflets, lectures, conferences, and so on. The campaign is a promising one, and for the sake of science as well as for national security, we trust it will be markedly successful.

AMONG the scientific men who lived during the Revolutionary Era in France few were held in higher esteem than Claude Louis Berthollet, the centenary of whose death occurs on November 6. Celebrated for his discovery, in 1785, of the composition of ammonia and, in 1786, of the bleaching properties of chlorine, he was one of the earliest converts to the new ideas of Lavoisier, and with Lavoisier, Fourcroy, and Guyton de Morveau, compiled the "Méthode de Nomenclature Chimique." During the Revolution his organising powers were devoted to maintaining a supply of saltpetre for the making of gunpowder, while with Monge and Clouet he did much to improve and extend the manufacture of steel. He also played a prominent part in the reorganisation of the Academies and the inauguration of the National Institute. Like Monge, he was a favourite with Napoleon and was one of the group of learned men who accom-

panied the young conqueror to Egypt. Among Berthollet's writings was his "Statique Chimique," published in 1803. He was the founder of the famous "Société d'Arceuil," of which Laplace, Biot, and Gay-Lussac were members.

THE secretary of the Swedish Medical Society has favoured us with the following particulars of the Anders Retzius medal which was awarded recently to Sir Charles Sherrington. The Anders Retzius foundation was given to the society on October 13, 1896, by Mrs. Emilie Retzius in memory of the hundredth anniversary of the birth of her late husband, Prof. Anders Retzius; and it is intended to promote studies of normal anatomy and physiology. From this foundation the Anders Retzius gold medal was for the first time awarded by the society to Albert von Kölliker in the year 1897. It has since been awarded successively on every fifth year to Carl Voit, Gustaf Schwalbe, John Newport Langley, and Oscar Hertwig, alternately in recognition of their prominent anatomical and physiological researches. The medal is sixty-nine millimetres in diameter, was designed by the Swedish medallist E. Lindberg, and represents Anders Retzius's portrait in profile.

MR. W. FRENCH, writing from the Storey Institute, Lancaster, directs our attention to a letter from Prof. A. C. Seward, published in the *Lancaster Observer* for September 22, referring to the state of the tombstone marking the grave of the parents of Sir Richard Owen and appealing to Lancastrians to contribute the comparatively small amount required for its restoration. Mr. French suggests that there may be many scientific men yet living who owe much of their success and inspiration to the writings and teachings of Sir Richard Owen, and would be willing to acknowledge in part their debt to him by contributing to the restoration of the tombstone of his parents. The estimated cost of the project is about 30*l.*, and Mr. French is willing to receive subscriptions and to give any further information that is required. We feel sure that readers of NATURE will share the desire of Prof. Seward and Mr. French that anything associated with the memory of so distinguished a man of science should be preserved and treated with the greatest reverence.

It has been announced in our columns (September 16, p. 394) that nearly 850*l.* had been subscribed in this country in support of the Pasteur centenary celebrations. This sum has been forwarded to the general treasurer of the fund, M. Th. Héring, who, in his reply acknowledging the receipt of the gift, states that any surplus of funds remaining after providing the monument at Strasbourg will pass to the Pasteur Foundation, which will probably institute Pasteur prizes for needy students. In February next, the Alliance Française, of 41 Fitzroy Square, W.1, is entertaining for a few days MM. Valléry-Radot, father and son, relatives of Pasteur, and Dr. Pasteur Valléry-Radot will give an address on the work of his illustrious grandfather. MM. Valléry-Radot will afterwards be entertained at dinner, probably at the Vintners' Hall.

In the *Daily Mail* of October 23 appears a note on the discovery of a human skull and bones in an ancient gold-working at Gwanda, Rhodesia. It is based upon an account of the discovery by Mr. Duncan Simpson, by whom the bones were found in July last. They lay under twenty feet of débris, and their position would suggest that the miner was working on the face of the reef when he was killed by a fall of the rock. This is supported by the fact that a large stone hammer lay near by, which, it may be assumed, he was using at the time. The bones are now in charge of Dr. Arnold of the Rhodesian Museum and are to be submitted to expert investigation. It is stated that on a cursory examination they are thought to be those of a Bantu. If, as the circumstances suggest, the remains are those of one of the original miners of the ancient gold-workings, in which this part of Rhodesia abounds, they are the first to be discovered. The confirmation of their Bantu origin would have an important bearing upon the problem of the origin of these gold-workings and of the highly developed ancient culture of Rhodesia which has so often been the subject of controversy. While it is highly probable that the workers were the slaves of a higher race, as suggested in the *Daily Mail* article, the Bantu origin of these early miners, in view of the comparatively late incursion of that race into this area, would preclude a very high antiquity for these workings.

A SNAP of cold and severe weather was experienced over the British Isles during the closing days of October, and temperatures were exceptionally low for so early in the winter season. Bitter easterly winds were prevalent under the controlling influence of a region of high barometer centred over Iceland and an area of low barometer readings situated over France and the Bay of Biscay. In the English Channel and on our south coasts the east winds attained the force of a gale. Snow fell in Cornwall and at many places in the southern counties on Saturday, October 28. According to the reports from the Meteorological Office, the thermometer on October 28 and 29 failed to reach 50° F. in any part of the Kingdom, whilst on October 29 the maximum at Falmouth, Newquay, Lympe, and Hampstead was only 39° F. and at night sharp frost was generally experienced, the exposed thermometer falling to 20° F. in many places. The Greenwich temperature records from 1841 show that in six years, 1859, 1869, 1873, 1880, 1890, and 1895, the maximum day temperature in October failed to attain 40°, on a single day, at least, subsequent to October 20. At Eastbourne the highest temperature on Sunday, October 29, was 42° F., and on three mornings, October 26, 27, and 29, the lowest temperature in the shade indicated a frost. October was generally cold and fairly dry in most parts of England, with a large amount of easterly wind, and was in marked contrast to the warm and bright weather experienced in the corresponding month of last year.

The anniversary dinner of the Royal Society will be held at the Hotel Victoria (Edward VII. rooms) on St. Andrew's Day, Thursday, November 30.

NO. 2766, VOL. 110]

THE annual exhibition of scientific apparatus organised by the Physical Society of London and the Optical Society will be held on January 3 and 4 next.

At the first ordinary meeting of the new session of the Royal Geographical Society, to be held on November 13 at 8.30 P.M., at the Aeolian Hall, a paper will be read by Commander Frank Wild on the work of the *Quest*.

THE Huxley Lecture of Charing Cross Hospital Medical School will be delivered at the school on Wednesday, November 8, at 3 o'clock, by Sir Arthur Keith, who will speak on "Evolutionary Tendencies in Man's Body." At 4 o'clock on the same day, at London Hospital Medical College, Dr. Percy Kidd will deliver the Schorstein Memorial Lecture. The subject will be "Forty Years in the History of Tuberculosis."

At a meeting of the Royal Society of Edinburgh on October 23, the following officers and members of council were elected: *President*: Prof. F. O. Bower. *Vice-Presidents*: Sir J. A. Ewing, Prof. J. W. Gregory, Major-General W. B. Bannerman, Dr. W. A. Tait, Principal J. C. Irvine, Lord Salvesen. *General Secretary*: Dr. C. G. Knott. *Secretaries to Ordinary Meetings*: Prof. J. H. Ashworth, Prof. R. A. Sampson. *Treasurer*: Dr. J. Currie. *Curator of Library and Museum*: Dr. A. Crichton Mitchell. *Council*: Prof. F. G. Baily, Dr. R. Campbell, Prof. J. Arthur Thomson, Dr. H. S. Allen, Sir Robert Blyth Greig, Dr. J. Ritchie, Prof. E. M. Wedderburn, Prof. T. H. Bryce, Prof. J. Y. Simpson, Prof. D'Arcy W. Thompson, Sir James Walker, Prof. E. T. Whittaker.

In her presidential address, delivered on October 19, to the Society for Constructive Birth Control and Racial Progress, Dr. M. C. Stopes dealt with the ideals and present position of constructive birth control. She stated that the social ideal urgently needed to-day is the revision of our present mistaken tendency to breed from defective stock more than from good and healthy stock. Acting as a motive force is also the individual human commiseration for the sufferings endured by unhealthy, over-burdened slum women, involuntarily the mothers of degenerate stock. Dr. Marie Stopes is of opinion that the Utopian idea is attainable through the use of scientific knowledge in such a way as to secure the increase from the best, and to decrease the population of low-grade human beings.

MESSRS. W. HEFFER AND SONS, LTD., booksellers, Cambridge, have recently purchased the interesting and valuable library of Prof. R. B. Clifton, late professor of natural philosophy in the University of Oxford. They have a catalogue in preparation. A copy will be sent post free on application.

WE have received from Mr. W. Rodier, 327 Collins Street, Melbourne, a letter and some pamphlets dealing with the rat problem as bearing upon the article by Mr. Alfred E. Moore in our issue of May 20 (vol. 109, p. 659). Mr. Rodier's scheme for the extermination of rats, known as "The Rodier System," which consists in liberating all the males trapped, is of course well known and its merits thoroughly appreciated by all interested in the destruction of



the rat. Mr. Moore, to whom we submitted Mr. Rodier's communication, sends us the following comments upon it: "Boelter, who joined me soon after I had initiated the British war on rats and mice, agreed with me that if we could get international, unified, and synchronised war on the rat, then and not till then could we hope to have any success from Mr. Rodier's method; we agreed that our first step must be to get the public fully to appreciate the disastrous nature of the rat menace, but that we could not afford to postpone rat destruction by all and every means until the day when unified effort was forthcoming. If Mr. Rodier agrees to work for an International Commission to bring about a proper understanding of the rat problem and concerted action, then I am sure all of us would gladly co-operate; but until we can get the public mind fully alive to the extent of the issue, I am sure it would be just as reasonable during the fly season to catch as many flies as possible and to liberate all the males: in this instance at any rate we should have a fair chance of seeing the progress of our work."

READERS of NATURE interested in topography may like to have their attention directed to a catalogue of some 230 books, maps, and engravings relating to London and its vicinity just issued by Mr. F. Edwards, 83 High Street, Marylebone, W. I.

Our Astronomical Column.

RECENT METEORS.—Mr. W. F. Denning writes that two large meteors were seen at Bristol on October 17 at 7.15 and 10.46. The first of these descended just under the "Pointers" in Ursa Major from 164° +52° to 161° +45°, and moved very slowly. The other meteor traversed an unusually long path of 113 degrees, the flight being from 163° +74° to 330° -6°. The duration was about six seconds, and the meteor threw off a bright streak all along its extended course. The radiant point was near the horizon in 152° +39°, but no further accounts of the object have yet been received.

The October meteoric shower has been fairly well observed this year, a remarkable succession of clear nights having occurred between October 10 and 21. The chief showers have been from Orion and Aries. Mr. Prentice at Stowmarket saw 246 meteors between October 10 and 18 in 34 hours of watching. The chief radiants in activity were determined by him as follows:

- α Arietids . 31° +19° 8 Meteors, October 13-15.
- ε Arietids . 41½° +22° 17 " " 14-18.
- ν Orionids . 90° +16° 10 " " 18.
- ζ Geminids . 98° +15° 8 " " 14-15.

These various showers are well known at this period of the year. The Arietids are slow-moving, brilliant meteors, while the Orionids and Geminids are swift, streaking meteors.

OCCULTATION OF ALDEBARAN.—On Monday next, November 6, the moon will occult the bright star Aldebaran in Taurus. The disappearance takes place at 10<sup>h</sup> 8<sup>m</sup> G.M.T., and the reappearance at 11<sup>h</sup> 20<sup>m</sup> G.M.T.

COMETS.—Numerous observations are to hand of the comet discovered by Dr. Baade on October 19. The comet is easily visible in a moderate telescope, and should be observable for some months. It is,

THE useful quarterly list of new books and new editions added to Lewis's Medical and Scientific Circulating Library for the months July to September has just been received. Copies are obtainable free of charge from Messrs. H. K. Lewis and Co., Ltd., 136 Gower Street, W.C.1.

MR. W. H. ROBINSON, 4 Nelson Street, Newcastle-upon-Tyne, has recently issued a catalogue of some 300 second-hand books of science. The prices asked seem very reasonable. An interesting item is a copy of the first edition in English of The Anatomical Exercises of Harvey, concerning the Motion of the Heart and Blood; with the Preface of Zechariah Wood, Physician at Rotterdam, to which is added Dr. James De Back, his Discourse of the Heart, containing a defence of Harvey's work.

A DIRECTORY for the British Glass Industry is being compiled under the auspices of the Society of Glass Technology. It will contain in classified form the names of all firms, associations, societies, trade unions, educational and research institutions interested in the manufacture and wholesale supply of glass and glass articles, and in the supply of raw materials, plant, and machinery to the industry. It is hoped to publish the volume by the end of the present year.

however, receding from the sun and earth. The following elements are by Middle. Vinter Hansen, from Copenhagen observations on October 22, 23 and 24:

$$\begin{aligned}
 T &= 1922 \text{ Oct. } 16^{\text{h}} 57^{\text{m}} \text{ G.M.T.} \\
 \omega &= 114^{\circ} 32' 07'' \\
 \Omega &= 219^{\circ} 50' 59'' - 1922^{\circ} 0. \\
 i &= 51^{\circ} 47' 00'' \\
 \log q &= 0.35890
 \end{aligned}$$

EPHEMERIS FOR GREENWICH MIDNIGHT.

	h.	R.A.	m.	s.	N. Decl.	log r	log Δ.	Mag.
Nov. 6.	20	28	4	32	36' 0			
10.	20	37	43	31	28' 1	0'3622	0'3035	10'1
14.	20	47	28	30	21' 4			
18.	20	57	18	29	16' 2	0'3646	0'3150	10'2
22.	21	7	10	28	13' 0			

The comet should be looked for high up in the southwest soon after sunset.

The search ephemeris lately given for Perrine's periodic comet did not include perturbations. M. Kasakov of Moscow finds that these are large, and gives the following elements:

$$\begin{aligned}
 T &= 1922 \text{ Dec. } 25^{\text{r}} 2. \\
 \omega &= 167^{\circ} 15' 21'' \\
 \Omega &= 242^{\circ} 18' 53'' - 1922^{\circ} 0. \\
 i &= 15^{\circ} 42' 56'' \\
 \phi &= 41^{\circ} 15' 63'' \\
 \mu &= 537'' 538.
 \end{aligned}$$

EPHEMERIDES FOR GREENWICH MIDNIGHT WITH TWO ASSUMED DATES OF PERIHELION.

	h.	Perihelion Dec. 21.2.			Perihelion Dec. 25.2.		
		R.A.	m.	N. Decl.	R.A.	m.	N. Decl.
Nov. 10.	21	14	5	5° 29'	20	58	7 3° 9'
18.	21	17	53	4 35	21	17	53 2 33
26.	21	59	34	3 52	21	40	32 2 9
Dec. 4.	22	27	1	3 21	22	5	53 1 58

It is some 26° south of the other comet, but considerably fainter.

## Research Items.

**A LONG BARROW IN BRECONSHIRE.**—In the October issue of *Man*, Mr. C. E. Vulliamy describes the results of his excavations of a long barrow at Talgarth in Breconshire, on a foothill of the Black Mountain range. The chamber and its contents had been disturbed, but not in recent times. At an early stage a calcined thigh-bone of a youth was found, but lower down there were abundant human remains, much broken and seldom lying in anatomical relation to each other, but showing no evidence of cremation. Sir Arthur Keith, who has examined the fragments, finds one skull of a man about forty years of age, the cephalic index 70, a very narrow, relatively high, and rather small head, 20 mm. narrower than previously recorded in Neolithic skulls from Wales. Associated with the human remains were bones of the pig, ox, goat, and cat, and quantities of flint flakes and scrapers are scattered over the neighbourhood.

**A THIRD-CENTURY BIRMINGHAM.**—Preliminary excavations have just been completed on the site of what the *Times* calls "a third-century Birmingham," Ariconium, in the Wye valley between Monmouth and Gloucester, near Weston-under-Penyard, three miles from Ross. Over an area of more than 100 acres the earth is full of smelting refuse; evidently a great iron industry flourished there, the iron ore being brought from the Forest of Dean. The only classical reference to the place is in the Itinerary of Antonius, compiled about 150 A.D., and in the fourteenth century the Benedictine monk Richard of Cirencester refers to it. Some buildings have been found, the walls of which were decorated in column. A large quantity of pottery, fragments of Samian ware, and a coin of Domitian dated 87 A.D. were also discovered. Ariconium seems to have arisen as a halting-place on the Roman road from Caerleon to Silchester in the first century, and it became a busy industrial town in the third. The results of these excavations justify their continuance on a wider scale.

**BACTERIOLOGY OF CANNED MEAT AND FISH.**—The results of an investigation by Dr. W. G. Savage and Messrs. R. F. Hanwicke and R. B. Calder on the bacteriology of canned meat and fish have been published by the Food Investigation Board as Special Rep. No. 11 (H.M.S.O., price 2s. 6d. net.). The report is based on the examination of 344 samples, the object being to ascertain the character of bacteria concerned in the spoilage of these canned foods. Moulds and yeasts are of rare occurrence and probably of little importance. Obligate anaerobic bacilli are rarely present in sound tins, but were nearly always associated with obtrusively decomposed conditions in the tin. Sporing aerobic bacilli are frequent in sound samples, and many of them must be regarded as potential causes of decomposition; they are unable to develop in sound tins from which air is excluded and persist as harmless spores. Non-sporing bacilli were found in many samples, their importance depending upon their biological characters. Thus, strains of *B. proteus* are important causes of decomposition. Thermophilic bacteria (*i.e.* bacteria growing best at 55° C.) were searched for and found to be widely prevalent but, being non-proteolytic, are unlikely to cause spoilage. Micrococci are infrequent and as a group cannot be regarded as a cause of spoilage, though they may assist more proteolytic types of organisms. Nearly 62 per cent. of sound tins are not sterile, the worst offenders being crab and lobster. Sterility itself is therefore not a criterion of sound-

ness, and these surviving bacteria do not in any way injure the foods in which they are present owing to their inability to multiply and produce decomposition under the conditions existing. Suggestions are made respecting the process of manufacture so as to reduce spoilage to a minimum.

**FLOWER STRUCTURE IN THE LECYTHIDACEÆ.**—Prof. McLean Thompson has published a further study of floral morphology in the Lecythidaceæ, a peculiar tropical family with large fruits, related to the Myrtaceæ (Trans. Roy. Soc. Edin., Vol. 53, Part I, No. 13). The present paper is devoted to a study of the flowering and certain stages in the floral development of *Napoleona imperialis*, the first member of the West African genus *Napoleona* to be described, in 1786, by a French writer. The peculiarities of the flower include so-called inner and outer corollas with a series of petaloid filaments between them. Many interpretations have been placed upon these structures. The floral development indicates that the petaloid filaments and the outer corona have taken the place of the outer cycles of stamens in the Myrtaceous flower, as Bentham supposed. The style is surrounded by a fleshy glandular disc which is considered to be a remnant of an inner stamens-bearing whorl.

**HAWAIIAN GRASSES.**—A comprehensive account of the grasses of the Hawaii islands, which is based on special collections made by the author in 1906, and on all accessible material gathered by other observers, is provided in *Memoirs of the Bernice Pauahi Bishop Museum*, Vol. VIII. No. 3 (Honolulu), "The Grasses of Hawaii," by A. S. Hitchcock. The preliminary discussion deals with the distribution from an ecological standpoint, with the chief agricultural grasses, and with introduced species. A large number of the grasses of the islands have been introduced, 83 species in all, mostly from Europe, a few from Australia and the East Indies. Many of the 47 native species are endemic, and most of the others have extended northwards to Hawaii from the East Indies and the southern Polynesian islands. Of the 39 endemic species 7 are annuals, all belonging to the genus *Panicum*. The second part is systematic and gives a full description of each species, the necessary keys being provided; 9 new species are described, together with a new section of *Poa*, *Siphonocoleus* sect. nov. The treatise should provide a useful and well-arranged reference work for students of the Gramineæ.

**WEST INDIAN HURRICANES.**—An article on the formation and movement of West Indian hurricanes by Mr. E. H. Bowie of the U.S. Weather Bureau appears in the U.S. *Monthly Weather Review*, April 1922. The area of first appearance is described as extending from latitude 10° to 25° N. and from longitude 56° to 95° W. During a period of 35 years, 90 per cent. of the West Indian hurricanes are said to have had their origin within and not without this area. It is asserted that some years pass without hurricane formation, while other years are notable for hurricane frequency. The origin of a hurricane is by no means certain, and the author states it is even now difficult and next to impossible to say which of the many hypotheses is the correct one. The prevalent supposition of the origin is the meeting of adverse currents, having different temperatures, which produce gyrotory motions of the atmosphere. Many men of science are of opinion

that tropical cyclones are essentially convectional phenomena. Observations in the free air in and around a tropical cyclone are not available. Dr. V. Bjerknes, in his theory of the polar front, has recently given a new conception of the part that local wind systems play in the formation of cyclones. The author states that it would seem that the cause of the origin of the tropical cyclone may be found in the counter current theory as to initiation of the cyclone centre, while the convective theory accounts for its maintenance after having started. Much information is given on the movement of hurricanes, and there are numerous charts showing the travelling centres in association with the surrounding distribution of atmospheric pressure.

LOCAL OR HEAT THUNDERSTORMS.—The U.S. *Monthly Weather Review* for June gives an interesting and instructive account of the development of thunderstorms by Prof. C. F. Brooks, of the Clark University, which was presented before the American Meteorological Society in April last. The supply and action of the ascending and descending currents of air are explained, as well as the formation and effect of rain in the development of the storm. The physical make-up of the thunderstorm is said to develop quickly into a central descending and out-flaring current of cold air, surrounded by a cone of rising warm air, and still farther out by a zone of descending air. A thunderstorm is described as the result of relatively large streams of air in violent convection attended by abundant condensation of moisture. With reference to the rapid rising of air in cumulus clouds that are growing into cumulonimbus, the author remarks that on different occasions his rough measurements have shown upward motions of 3, 4, and 7 metres per second in the tops of cumulus clouds. Aviators and aeronauts who have been within active portions of cumulo-nimbus clouds have experienced great bumpiness owing to the strong up-and-down currents. Violent convection is said to be caused by the instability accompanying a large lapse rate in temperature. Abundant condensation of moisture is essential to the start of a thunderstorm. The gist of the communication is the predicting of local thunderstorms, and certain questions are formulated for the forecaster relative to streams of air, convection, and condensation. It is suggested that the conditions be tabulated and that use be made of a + or - answer, the summing up of which will indicate whether local thunderstorms are probable. Important information is given as to where local thunderstorms originate.

THE SPHERE-GAP VOLTMETER.—When it is necessary to measure the maximum or peak voltage of an alternating current from a transformer or induction coil the sphere-gap voltmeter is often used, as its indications are independent of the humidity of the air and of the form of the voltage wave. The following particulars of such an instrument at the National Physical Laboratory, furnished by Dr. E. A. Owen in the October issue of the *Journal of the Röntgen Society*, will prove useful. The spheres, 7.62 cm. in diameter, are mounted on ebonite pillars 21 cm. long, with sulphur rings 5 cm. long let into them for additional insulation. One sphere is fixed and the other supported on a slide which can be moved towards the fixed sphere by means of a screw. A scale on the slide gives the distance apart of the spheres at their nearest points. The spheres are connected to the supply and are moved slowly towards each other till a spark passes. The peak voltage is then deduced from the distance apart by the following

data: 1 cm. 32.7 kilovolts; 2, 60; 3, 86; 4, 196; 5, 124; 6 cm. 141 kilovolts.

OZONE.—Prof. E. H. Riesenfeld, of Berlin, has recently described (*Chemiker Zeitung*, October 7) the preparation and properties of pure ozone. Ozonised oxygen containing 10-15 per cent. of ozone was liquefied in exhausted glass bulbs by cooling in liquid air. The deep blue liquid, on exposure to reduced pressure, gave off mainly oxygen, and at a certain composition separated into two layers: the upper, dark blue, layer was a solution of ozone in liquid oxygen; the lower, deep violet-black, layer was a solution of oxygen in liquid ozone. The lower layer, formerly considered to be pure ozone, contains about 30 per cent. of oxygen at  $-183^{\circ}\text{C}$ . The oxygen was pumped off from it, and pure liquid ozone (B.P.  $-112.4^{\circ}\text{C}$ .) obtained. The vapour density of 48 ( $\text{O}_3$ ) was found by Dumas' method. On cooling in liquid hydrogen, solid ozone, in violet-black crystals, M.P.  $-249.7^{\circ}\text{C}$ . was formed. The gas, deep blue in colour, is, in the absence of all catalysts, remarkably stable. Pure gaseous ozone can be exploded by an electric spark, but some remains unchanged. This would be expected from the endothermic character of the substance. The critical temperature is  $-5^{\circ}\text{C}$ . No evidence whatever of the existence of higher polymers of oxygen was obtained: both in the liquid and gaseous states the formula is  $\text{O}_3$ . This work is of great interest, and, apart from the determination of the physical properties of ozone, it removes the last doubt as to the simple character of ozone—"oxozon" does not exist.

DIFFERENTIAL GAS ANALYSIS.—Mention has already been made in NATURE of a method devised by Dr. G. A. Shakespear of Birmingham University for measuring differences in composition of similar gas mixtures. The method, which has proved itself valuable for controlling the purity of hydrogen, the safety of atmospheres in balloon sheds, and many other purposes, depends on the differences of thermal conductivity of gases. Two identical spirals of platinum wire are enclosed in separate cells in a metal block, each spiral forming one arm of a Wheatstone Bridge circuit, the other two arms being of manganin. An electric current flowing through the bridge thereby heats the two spirals, which lose heat to the walls of the cells. If the two cells contain gases of different thermal conductivities the spirals will cool at different rates, and one spiral will therefore be maintained at a higher temperature than the other. The difference in temperature of the two wires thus causes a deflection of the galvanometer, the extent of which depends on the difference in conductivity of the two gases. The construction is such that changes in the temperature of the gases affect both sides of the bridge equally. If, therefore, one cell contains a pure gas, and the other cell the same gas mixed with some other constituent, the extent of the deflection will indicate the proportion of the second gas present, and the galvanometer can be calibrated to show directly the percentage composition of the mixture. The difference in conductivity between air and carbon dioxide enables the method to be used to determine the percentage of carbon dioxide in flue-gases. The other constituents of flue-gases either have thermal conductivities differing but little from those of nitrogen, or are negligible in amount, while the effect of the water vapour can be counteracted by keeping the gases in both cells saturated. By attention to certain details the method may be then applied to follow the change in carbon dioxide content of the flue-gases in fuel-consuming installations. The instrument is made by the Cambridge Scientific Instrument Company.

### The Origin of Magnetism.

WHEN the proposal was first made to hold in Section A of the British Association at Hull this year a discussion on "The Origin of Magnetism," it was met with the criticism from eminent quarters that the time was not yet ripe for the consideration of this subject. Those who attended the meeting will probably agree that this view was justified, for it can scarcely be said that the position was advanced appreciably, or that any real, or even plausible, answer was given to the main question involved. Perhaps this was in some measure due to the regrettable absence of Prof. Langevin, who had promised to make the opening remarks, and had expressed his intention of using the opportunity for a critical survey of the whole subject. But a recurrence of the ill-health from which he has intermittently suffered for a long time deprived the Section of Prof. Langevin's presence and his eagerly anticipated contribution to the discussion. As it was, the discussion lacked co-ordination; the remarks of the various speakers bore little relation to one another. There was the exposition by Prof. Weiss of his theory of the molecular field and the existence of magnetons; then Sir J. A. Ewing's description of his new molecular magnet models; then the remarks of Dr. A. E. Oxley on the changes of susceptibility imparted to platinum and palladium by the occlusion of hydrogen; and, finally, an account by Mr. L. F. Bates of the measurements of the Richardson effect recently carried out by Dr. Chattock and himself,—all contributions of considerable individual interest, but not closely related to one another nor providing an answer to the essential question of the *origin* of magnetism.

In spite of the comparative failure of the discussion in its wider aspects, one felt that the time had not been wasted, principally because it afforded an opportunity for Prof. Weiss to give a most interesting account of his work in connexion with ferromagnetism and paramagnetism, which is not too well known in this country. Prof. Weiss at very short notice undertook to open the discussion in place of Prof. Langevin, and a fairly complete account of his remarks will eventually appear in the Report of the Association. An outline of this exposition may be profitable here.

Starting from the analogy of the difference between the laws of fluid compressibility for low and high densities, Prof. Weiss showed how Langevin's kinetic theory of paramagnetic substances may be modified so as to include strong magnetism—or ferromagnetism—by the assumption of the existence of a *molecular field* analogous to van der Waal's internal pressure in fluids. A whole array of experimental facts was brought forward in support of this theory of the molecular field. It provides an explanation of the variation of magnetic saturation with temperature; it accounts precisely for the transformation of ferromagnetism to paramagnetism at the temperature of the Curie point, and for the observed law of this paramagnetism. The theory also points to a discontinuity of specific heat at the Curie point, and the magnitude of the discontinuity, calculated from magnetic data, agrees with calorimetric measurements. Still more interesting is the recently discovered magneto-caloric phenomenon, which consists of a reversible temperature variation accompanying magnetisation. This differs from the ordinary hysteresis effect, which is irreversible, and always involves heating. In the reversible effect, magnetisation produces a rise of temperature and demagnetisation a fall. At the Curie point the change is by no means negligible, reaching, as it does, a value of about 1°

in fields readily attainable. The extent of temperature variation calculated by means of the molecular field theory agrees with that observed.

When one comes to calculate from various experimental data the numerical value of the molecular field, it proves to be of the order of magnitude  $10^7$  gauss, which is far in excess of the magnetic field which might in the most favourable circumstances be produced by the magnetic moments of the molecules of a ferromagnetic body, namely,  $10^4$  gauss. This remarkable result indicates that the so-called molecular field has not itself a magnetic origin. In this connexion Prof. Weiss's own (translated) words are worth quoting:—

"It is therefore impossible for the mutual actions represented by the molecular field to be of a magnetic nature. It is just a notation for forces of a non-magnetic character, with a symbol borrowed from magnetism. I prefer, in place of the primitive definition given earlier, the equivalent definition

$$H_m = -\frac{\delta U}{\delta I},$$

where  $U$  is the intrinsic energy per unit volume, and  $I$  the intensity of magnetisation. This definition is advantageous in that it does not prejudice the nature of the forces. . . . It does not appear to be impossible that the forces may be electrostatic; that, however, is at present a pure supposition."

In the second part of his address Prof. Weiss directed attention to another important aspect of the combined kinetic theory of Langevin and his own theory of the molecular field. The possession of these theories permits the calculation of the values of the molecular or atomic magnetic moments which have been the underlying assumption in all theories of magnetism. A great number of atomic moments have thus been evaluated from many experimental sources, such as the measurement of the magnetisation of ferromagnetic substances and their alloys both in the neighbourhood of absolute zero and above the Curie point, the investigation of the paramagnetism of solutions of salts, and the like. The general law which emerges is that "all atomic moments are integral multiples of the same elementary moment, to which the name *magneton* has been given." For example, six different and independent observers have found for nickel, over a temperature interval of about  $400^\circ, 8\cdot03, 7\cdot99, 8\cdot04, 8\cdot05, 8\cdot03$  and  $7\cdot98$  magnetons respectively, numbers which, it will be seen, are in the immediate neighbourhood of the integer 8. It is, besides, a general property of atoms to possess different integral numbers of magnetons according to various conditions, such as their state of chemical combination, or their temperature, whether in the ion, or in the undissociated molecule. Prof. Weiss affirms that the magneton is a real entity, and he pointed to the fact that the Rutherford-Bohr atom, together with Planck's quantum theory, actually does indicate the existence of a universal elementary magnetic moment, which, however, proves upon calculation to be almost exactly five times as great as the magneton.

Prof. Weiss's general conclusions may be summed up by quoting him again:—

"1. One of the essential conditions for the production of strong magnetism—or ferromagnetism—is the existence, between molecules possessing magnetic moments, of important mutual actions which are numerically expressed by the molecular field, and are certainly of a non-magnetic nature.

"2. The appearance of atomic moments as integral multiples of the same elementary moment—the magneton—is thus one of the important aspects of magnetic phenomena."

Altogether a convincing exposition, in spite of Sir Ernest Rutherford's amusing allusion to the fascination which *whole numbers* have for physicists.

A. O. RANKINE.

### Man and the Ice Age.

OF the many discussions which took place during the recent meeting of the British Association at Hull, few are likely, on purely scientific grounds, to prove of more importance than that on the relation of man to the ice age in Britain, in which the sections of geology, geography, and anthropology took part. It cannot be said that any agreement was reached; but the significance of the discussion lies in the fact that protagonists of different schools of thought in geology were brought face to face, while archaeologists and geographers were able to formulate and lay before them problems for the solution of which they await the assistance of geologists. In considering the problems of the ice age, geologists and archaeologists are dealing with the same material, but each from their special point of view. The result has been a difference in nomenclature and method of classification: the geologist thinks in terms of the deposits; the archaeologist in terms of the artefacts found in them. Consequently, as Prof. F. F. Kendall pointed out, any discussion between them is likely to come to a deadlock through disparity of nomenclature. This discussion, however, showed that the difficulty is by no means insuperable.

It was apparent at an early stage in the discussion that there existed a clear-cut difference of opinion as to the method of approach in attacking the problem. Indeed the title of the discussion, in suggesting a restriction of the subject matter to Britain, was a challenge which Prof. W. J. Sollas was not slow to take up, when at the outset he maintained that it was impossible to consider the evidence in Britain apart from conditions on the Continent. Prof. Kendall, on the other hand, held that not merely must consideration be confined to the evidence as it is presented in the British area alone, but that the solution of the problem must be sought in East Anglia in the relation of the northern drift to the chalky boulder clay. On this point, Prof. Kendall's lucid summary of the evidence gave his audience a clear indication of the nature of the problem and of the extent to which the British data may be expected to throw light upon the problem as a whole. It turns to a great extent upon the view which is taken of the relation of the glacial deposits of Yorkshire to those of East Anglia. The chalky boulder clay of East Anglia was carried down by ice from north of the Wash and the fens. In Yorkshire there is a clear glacial sequence of at least three boulder clays, in the lowest of which is a Scandinavian element. In Prof. Kendall's opinion the hope of correlating the Yorkshire evidence with that of East Anglia is to be found in the Wolds, on the west of which is found the purple clay of Yorkshire, and on the east, the chalky boulder clay. Was it possible, he asked, that the latter might be the purple clay transformed by its passage over the Wolds?

The trend of the discussion was to show that the archaeological problem is narrowing down to the question of the relation of the gravels containing Chellean and Acheulean implements to the boulder clay, a definite issue for solution by excavation. At Hoxne, such implementiferous gravels were found to overlie a boulder clay, but the evidence is by no means entirely conclusive and appears to conflict with that from elsewhere. Prof. Boswell had hoped to be in

a position to place before the sections the results of excavations undertaken to determine this point, but, unfortunately, they had not been completed in time. On the other hand, Mr. Hazzledine Warren showed himself an uncompromising opponent of anything but a post-glacial date for the palæolithic gravels, on the ground that they are conformable to the holocene alluvium, a condition which would be impossible had they been subjected to glacial action. The general disposition appeared to be, however, that further evidence on this clear crucial point must be awaited. On the whole, this would appear to be in agreement with the tendency of the opinions which have been elicited by the British Association Committee appointed at the Cardiff meeting to report on the relation of early types of palæolithic implements and glacial deposits. Of these some have appeared in *Man*; others await publication.

The interest of archaeologists and geographers, however, is not bounded by the position of man in relation to glacial deposits in this country. They would wish to know how far conditions in this country can be equated with conditions in the Continental area, extending this term to include North Africa, and how far it is possible by geological evidence to link up the palæolithic cultures of this country with the cultures of these areas. They welcomed, therefore, the opening remarks of the president of the anthropological section, Mr. Peake, in which he referred to the tentative scheme for effecting this which he had put forward,<sup>1</sup> and the pronouncement of Prof. Sollas that the British evidence could not be considered apart from the Continental evidence. Prof. Sollas ably summarised Penck's views, and pointed out how the differences between the French and German geologists might be reconciled—differences however, which did not affect the question of the geological age of man. Penck's four great periods of glaciation in the Eastern Alps could be correlated with the river gravels, while in France glaciation could be brought into relation with raised beaches. As a result of such a correlation, it appeared that the Chellean implements belonged to a warm period, the Riss-Würm, the Mousterian straddled the Würm, and the Aurignacian and later phases of palæolithic culture were post-Würm.

The point of view of the archaeologist and geographer was well put by Prof. H. J. Fleure. The archaeologist in particular has arrived at certain conclusions on purely archaeological evidence, for which he looks to the geologist for confirmation or the reverse. Prof. Fleure pointed out that the three centres of glaciation, Scandinavia, Britain, and the Alps, could not be considered apart. Any change in the distribution of ice in one area was bound to affect the climate and distribution of ice in the others. It was therefore incumbent upon the geologists to produce a scheme applicable to all areas.

An interesting question to which Prof. Fleure alluded is raised in the relation of the Bühl period, which was marked by a readvance of the ice, to the conditions in Scandinavia described by de Geer. The study of climatic conditions may also be expected to throw light upon the problem. Prof. Fleure pointed out that a constant anticyclone over the

<sup>1</sup> *Man*, 1922, No. 5.

glaciated region would cause a constant succession of cyclones accompanied by a high rainfall over the Mediterranean and Western Asia. This would support the view that the desert belt of the Sahara was then more to the south, thus accounting for the vast number of palæolithic implements, accompanied by ostrich shells, found in that area. It would also strengthen the probability that man drifted north as the climate improved after the Würm period, and confirm the suggestion of the archaeological evidence that after the Aurignacian period there is no break.

A series of recent investigations on the south coast in Hampshire and Sussex, which were described by Dr. L. S. Palmer, bear very directly upon the question of the equation with Continental deposits. Dr. Palmer, who worked in collaboration with a geologist, had endeavoured to relate climate and deposits with implements. As a result, the 100 ft. terraces and beaches show a warm fauna associated

with Acheulean and early Mousterian implements; the 50 ft. and 15 ft. terraces a cold fauna associated with Mousterian implements, the cold period being interrupted by a slightly warmer period which justified the division of this phase into two parts. In the superficial brick earths were the Aurignacian, and over the latest Combe rock were the Magdalenian implements. Dr. Palmer found a correspondence between climate, culture, and land oscillations. The investigations were carried out without reference to nomenclature, but on comparison, corresponded with the Continental system of Penck.

At this point the discussion closed. If it had attained no very definite conclusion, the air had been cleared. One definite question has been formulated for further investigation, and it has been shown that a considerable body of opinion is approaching some kind of an agreement as to the manner in which the evidence in Britain may be brought into relation with that of the Continent.

### Generation and Utilisation of Cold.

THE general discussion on the generation and utilisation of cold which was held at the Institution of Electrical Engineers on October 16 was organised jointly by the Faraday Society and the British Cold Storage and Ice Association.

Consequently Dr. C. A. Crommelin communicated Prof. Onnes's paper as well as his own.

The Leyden cryogenic laboratory has been engaged on low-temperature investigations for the past thirty-five years, and such magnificent work has been done there that any communication emanating from this specialised institution is read with considerable interest.

Dr. Crommelin's paper was of the nature of a general description of the methods of experiment whereby they obtained any desired temperature below zero centigrade and maintained this temperature constant within  $0.01^{\circ}\text{C}$ . The equipment of the cryogenic laboratory is essentially a series of plants working on regenerative Pictet cycles down\* to liquid nitrogen temperatures. Below this, liquid hydrogen and liquid helium are employed. In the Pictet cycles methyl chloride, nitrous oxide, ethylene, methane, oxygen, and nitrogen are used. Any one of the substances boiling under appropriate pressure will give a range of steady temperatures. By these means a range from  $-24^{\circ}\text{C}$ . to  $-270^{\circ}\text{C}$ . is obtained which is complete but for short gaps.

Cryostats containing the different liquids are thermally insulated by vacuum walled vessels and the losses reduced to a minimum by the immersion of the apparatus in baths of the commoner elements such as liquid oxygen.

For the range  $-259^{\circ}$  to  $-269^{\circ}\text{C}$ ., which cannot be obtained by the use of a boiling liquid, a hydrogen vapour cryostat is employed, the vapour being heated electrically to the desired temperature and circulated around the experimental bulb.

The paper also contains some interesting data as to the capacity of the plant, and it is stated that liquid hydrogen can be produced at the rate of more than 13 litres per hour. A high degree of purity is required in the gases employed, and it appears that

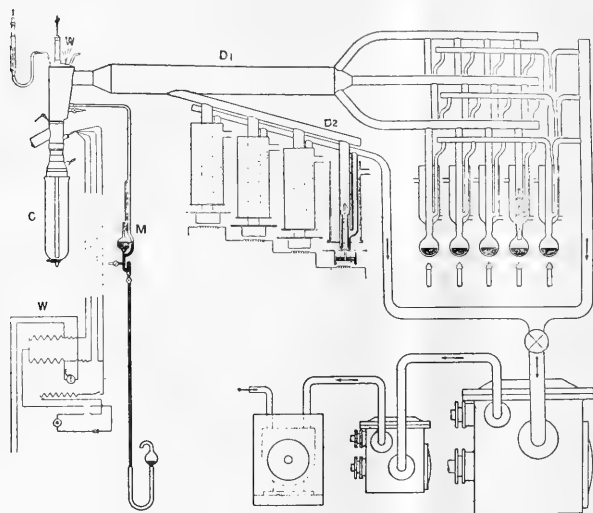

FIG. 1.—Apparatus used in attempt to solidify helium.

C, helium cryostat; M, McLeod gauge; W, resistance manometers; D<sub>1</sub>, connexion to glass Langmuir pumps; D<sub>2</sub>, connexion to iron Langmuir pumps.

Although the papers read at the meeting dealt with various aspects of the liquefaction of gases, there were no contributions from the refrigerating industry. Possibly the applications of cold for the preservation of food stuffs have become so standardised that our refrigerating engineers do not interest themselves in new developments. It was intended that the opening paper of the discussion should be read by Prof. H. Kamerlingh Onnes, but owing to the death of his colleague, Prof. Kuenen, he was unable to be

the ordinary liquid air process of producing oxygen does not give gas of sufficient purity.

Prof. Onnes's paper contains an account of his attempts at producing solid helium and, of course, the attainment of the lowest temperature. His original experiments with helium date back to fifteen years ago, when he found that liquid helium boiling under the lowest pressure he could produce (about 2.2 mm.) did not solidify. The temperature was estimated as 1.15° absolute. In 1920, Onnes determined to make a fresh attempt, using the best pumps available for reducing the pressure. Batteries of Langmuir condensation pumps were constructed, twelve of glass and six of iron, all working in parallel and delivering into two Burckhardt vacuum pumps connected in series with a Siemens oil pump. The largest Burckhardt pump was capable of dealing with 360 cubic metres of gas per hour. A diagram of the experimental arrangements is shown in Fig. 1.

The complete battery of pumps was capable of removing one litre (N.T.P.) of gas per hour under a suction pressure of 0.005 mm., but owing to the gas friction in the apparatus, the actual pressure produced at the surface of the helium was only 0.012 to 0.014 mm. Under these conditions the lowest temperature attained was 0.82° absolute. Even then helium did not solidify.

Not the least difficult part of these investigations is the measurement of temperature. The actual temperature of the liquid is obtained by calculations based upon the general equation of Van der Waal and extrapolating the temperature vapour pressure relationship for helium. The form of the extrapolated curve was compared with those obtained for various other elements as the line shows a decided curvature at normal temperatures. At the meeting Prof. Porter discussed the theoretical basis of this method of extrapolation and the possible error.

The two papers from the Leyden laboratory should prove of material assistance to the student interested in the technique of low-temperature investigations.

The industrial application of the liquefaction processes was dealt with by three speakers. Mr. K. S. Murray gave a general account of the processes employed by the British Oxygen Co. It was interesting to hear that the efficiency of the liquefaction process is not appreciably greater than that of the old barium oxide process using the reversible pressure reaction. The advantage of the liquefaction process is that it produces a purer gas. Figures for the cost of producing oxygen were given, as well as technical descriptions of the various types of rectification apparatus.

The second paper was sent by M. Claude, and in it was described a plant for the separation of hydrogen from water gas by a liquefaction process. The method can be utilised when the gas, such as that from coke ovens, is too impure to permit of the use of the catalytic reaction depending upon the con-

version of carbon monoxide to carbon dioxide. The plant described is used for supplying hydrogen to a synthetic ammonia apparatus producing 5 tons of ammonia per day. An interesting feature of the apparatus is the introduction of small amounts of nitrogen into the system to serve as liquid nitrogen lubricant in the expansion engine.

In the third paper, Mr. E. A. Griffiths gave an account of the use of oxygen in breathing apparatus for airmen, and also of the plants for manufacturing liquid oxygen for this purpose. The chief difficulty in the use of cold liquefied oxygen is that of storage and transport. The mechanism of the metal vacuum vessel, which is the only practicable solution of the problem, was briefly dealt with. The manufacture of these vessels is a simple matter, and the thermal losses in properly constructed vessels is 12 per cent. of the liquid oxygen content per day for a flask of two litres capacity, while for a twenty-five-litre flask it is only 4½ per cent.

The vaporisers for converting the liquid oxygen into gas at a rate which can be kept under control were described. In view of the simplicity of these devices, it is surprising that greater use is not made of liquid oxygen in medical and experimental work.

The portable plants employed for producing oxygen utilise both the Claude and the Linde principles. Although the theoretical efficiency of expansion with external work is about three times that possible with the Joule-Thomson free expansion, the actual results obtained on test are not appreciably different. This appears to be due to the practical limitations of the expansion engine. A similar conclusion was arrived at independently by Mr. Murray in the case of large plants.

The expenditure of power for the production of oxygen is of the order of 2½ to 3 H.P. per litre/hour: the figure for the Pictet cycle, according to Crommelin, is decidedly lower, being only 1.64 H.P. per litre/hour. The over-all efficiency of liquefaction processes is therefore extremely low and generally less than 3 per cent.

The remaining papers were contributed by investigators working under the direction of the Engineering Committee of the Food Investigation Board (Department of Scientific and Industrial Research).

Dr. Ezer Griffiths dealt with the determination of thermometric lag in various types of thermometers and with some new materials for thermal insulation at low temperatures.

Prof. C. F. Jenkins gave a summary of his work on the thermal properties of ethyl chloride. His research on this substance is an extension of his previous work on carbon dioxide. The data which he has now obtained should be of considerable value to the refrigerating engineer, for ethyl chloride has many advantages over ammonia and carbon dioxide for use in small refrigerating plants.

E. A. GRIFFITHS.

### Propagation of the Sound of Explosions.

IT has frequently been noted that on the occasion of great explosions there are curious anomalies in the propagation of the sound. Usually there is a normal zone of audibility in the immediate neighbourhood of the explosion, beyond this a zone of silence, where the sound is not heard, and again outside the zone of silence a second zone of audibility. It is remarkable that while an observer at say 50 miles away may not hear an explosion, an observer at 80 miles may hear it distinctly.

These abnormalities are closely connected with the meteorological conditions, though the detailed

relationship between them is not known. One theory is that the wind lifts the sound over an area and brings it down again many miles away. Another theory ascribes the zone of silence to the effect of the distribution of wind and temperature at high altitudes. The theoretical development of the problem is extremely complex, and so it was decided to make an experimental study of the meteorological conditions along with detailed observations of the extent of the zone of silence in the hope of elucidating the relationship between them.

The International Commission for the Investigation

of the Upper Air appointed a sub-commission to consider the problem set out above, and the sub-commission applied to various Ministries of War with the view of obtaining their collaboration in the case of obligatory destruction of explosives. The first favourable reply came from the Dutch Ministry of War, and it was finally arranged that at 17h. G.M.T. on October 28, five tons of ammonium perchlorate should be exploded on the Oldebroek Artillery Drill Ground (longitude  $5^{\circ} 59' 40''$ ; latitude  $52^{\circ} 29' 56''$ ).

In this country arrangements were made by the Meteorological Office for the observers at all the observatories and reporting stations to listen for the sound, and to make notes regarding the meteorological conditions at the time. Where possible, observations of wind and temperature in the upper air were also made. In addition, through the medium of the Press, the public were also invited to forward to the Meteorological Office notes of any observations made.

Up to the time of going to press a total of more than one hundred reports have been received and it has not yet been possible to examine them in detail. The most distant points at which the explosion is alleged to have been heard are North Wales and Northumberland. Two valuable records have been obtained on the hot wire microphones of the Signals Experimental Establishment, at Woolwich, and at Biggin Hill (Kent) respectively.

As soon as the British observations have been examined and summarised, the results will be forwarded to the Dutch Meteorological Service for collation with continental reports.

### The Whitworth Scholarships.

SEVERAL important changes are indicated in the new regulations for Whitworth Scholarships which have been issued by the Board of Education. In 1923 six Whitworth Scholarships, each of an annual value of 125*l.* and tenable for three years, will be offered for competition, as well as two Whitworth Senior Scholarships of an annual value of 250*l.* tenable for two years. There are also Whitworth prizes which will be awarded to unsuccessful competitors for the scholarships, not exceeding 25 in number and of value 10*l.* each. The Whitworth Exhibitions (50*l.* tenable for one year) have been abandoned. The scholarships will be open to candidates whose age does not exceed 21 years, and the number of subjects in which candidates will be examined is limited to four. Candidates for the senior scholarships must be less than 26 years of age and will be examined in seven subjects.

The Board has also issued a circular directing attention to the changes, some of which were made last year, in order to render the requirements regarding candidates' practical experience in handicraft more consistent with the present arrangements for apprenticeship and training in mechanical engineering. The Board's experience shows that candidates may be divided into two groups, a large one consisting of candidates whose education since leaving school has been part-time, and for whom a full-time course of study is likely to be suitable, and a smaller one consisting of those who have already completed a full-time course and can take a further course of work of post-graduate standard. Hence the institution of scholarships and senior scholarships.

There still remain difficulties which the new regulations will not remove. In the four years between 17 and 21 years of age a hard-working evening student can reach the ordinary university degree standard in the subjects laid down for the

scholarship examinations, but has only touched lightly certain subjects which form part of any organised full-time course. If a scholarship is awarded to him, and he proceeds to a full-time course, he will find that he cannot be exempted from repeating a great deal with which he is perfectly familiar. This difficulty is a very real one, as is well known to every teacher who has been consulted by a successful Whitworth candidate regarding his choice of a suitable college. There is also the difficulty of finding a suitable opening in the works after having been away for three years between the ages of 21 and 24, a difficulty which has led to many promising young men abandoning practical life in favour of teaching.

The circulars issued by the Board convey the impression that they do not favour the plan followed by many of the former scholars, who spent their scholarship term in works offering special facilities for widening their practical experience, and at the same time continued their studies in part-time courses. There is a great deal to be said in favour of this plan, and a glance at the names of former scholars who followed it and have risen to eminence in engineering would appear to justify its reconsideration.

### University and Educational Intelligence.

BRISTOL.—The Bristol Medico-Chirurgical Society has offered the society's library as a gift to the University. The library comprises about 15,000 volumes (some rare and of great interest) and has been valued at more than 12,000*l.* It contains some rare books and receives more than 100 current periodicals in exchange for the society's journal. The council of the University has very gratefully accepted this magnificent offer, which will raise the medical library of the University to one of the most valuable medical libraries in the country. The advantage to the research worker of having access to such a library cannot be over-estimated.

CAMBRIDGE.—Mr. R. E. Priestley, Christ's College, has been elected to a fellowship at Clare College; Mr. M. C. Johnson, St. John's College, has been elected to the Arnold Gerstenberg studentship; Mr. N. J. T. M. Needham, Gonville and Caius College, has been elected to the Benn W. Levy research studentship in biochemistry.

The Syndicate appointed to draft Ordinances to carry out the provisions of the new statute admitting women students to the titles of degrees has been published. It is proposed to recognise Girton and Newnham Colleges as institutions for the higher education of women for the purposes of the statute. The total number of students at the two colleges (or at all institutions for the higher education of women, should any fresh college be recognised) who are receiving instruction in the University or working in the University laboratories or museums is not to exceed five hundred. The Council of the Senate may at any time inquire into the condition and management of a recognised institution for the higher education of women, and may, if it think fit, recommend the termination of its recognition. Women must reside nine terms, and in other such matters come under the same regulations as the undergraduates before admission to the titles of their degrees. Once the title has been conferred upon them, they become entitled to wear the same academic dress as that worn by a member of the University who has been admitted to the same degree. Women are to be admitted to courses of research and to examinations for diplomas sub-



stantially on the same terms as men. Residence already kept and examinations already passed will qualify past students for the same privileges as if the new regulations had been in force in earlier days.

The *Times* announces a bequest by the late Mr. A. M. Shield of some 90,000*l.* to the Cambridge Medical School. The only definite item mentioned is the foundation of a Marmaduke Shield scholarship of 100*l.* a year in human anatomy.

LEEDS.—The following appointments to the staff have been made by the Council of the University: Mr. R. B. Tasker, honorary demonstrator in anatomy for dental students; Mr. C. Holland Child, Mr. G. H. H. Russell, and Mr. R. B. Tasker, honorary clinical tutors in dental surgery; Dr. A. C. Monkhouse, research assistant in the fuel industries department, to work under the joint committee of the Institution of Gas Engineers and the University on gas heating, lighting and ventilation research; Dr. E. C. Porter, demonstrator in the department of leather industries; Mr. J. C. Mann, assistant lecturer in agricultural chemistry; Mr. S. J. Saint, assistant lecturer in agriculture; Mr. R. E. Edwards, demonstrator in agricultural botany; Mr. J. C. Leslie, district lecturer in agriculture; Mr. G. F. Pilling, assistant lecturer and demonstrator in agriculture; Mr. H. W. Swift, demonstrator in engineering; Mr. W. A. Wightman, demonstrator in organic chemistry; Mr. Thomas Henderson, demonstrator in inorganic chemistry; and Miss E. M. Hickman, demonstrator in the department of pathology and bacteriology.

MANCHESTER.—Applications are invited for the position of Keeper of the Museum in place of Dr. W. M. Tattersall, now of the University College of South Wales, Cardiff. The latest date for the receipt of applications, which should be sent to the Secretary of the Manchester Museum, is Friday, December 1.

Provision has been made in the Faculty of Technology, which formerly awarded an ordinary degree of B.Sc.Tech., to give a higher B.Sc.Tech. degree in various sections of technological science, one of which will be the chemistry of colouring matters.

In view of the retirement of Prof. H. B. Dixon from the chair of chemistry, a committee of past and present students are raising a fund to recognise his thirty-five years of distinguished service. The fund is to be devoted mainly to the provision of grants to enable students of chemistry to complete their courses, and it is also intended to set up in the chemical theatre a plaque or bust of Prof. Dixon. These objects necessitate a generous response on the part of old students and colleagues of Prof. Dixon, and those who have not yet subscribed are invited to send their subscriptions to Dr. Norman Smith at the University. A complimentary dinner will be held on October 8, further particulars of which can be obtained from Dr. J. E. Myers.

THE Association of Science Teachers and Association of University Women Teachers have organised a conference on the teaching of science in schools and colleges to be held on Saturday, November 25, at University College, London. The opening speakers will be Sir William Tilden and Mr. A. G. Tansley.

THE Parliamentary candidates of University constituencies, for the general election on November 15, are as follows (the names of new candidates are in italics):—Oxford (2).—Lord Hugh Cecil (U.); Sir Charles Oman (U.). Cambridge (2).—J. F. P. Rawlinson (U.); Prof. W. R. Sorley (U.); J. R. M. Butler (Ind.). London.—Sir Sydney Russell-Wells (U.); Prof. A. F. Pollard (L.); H. G. Wells (Lab.). Combined English (Manchester, Liverpool, Durham,

Leeds, Sheffield, Birmingham, and Bristol) (2).—H. A. L. Fisher (N.L.); Sir Martin Conway (U.); B. Faraday and Dr. S. Lawrence (U.), and L. Woolf (Lab.). Wales.—Sir E. J. Ellis Griffith (L.); T. A. Lewis (N.L.). Scotland (St. Andrews, Glasgow, Aberdeen, and Edinburgh) (3).—Sir Henry Craik (U.); Sir George Berry (U.); D. McCoig Cowan (N.L.). Queen's, Belfast.—Sir William Whitla (U.).

THE list of successful candidates in the open competition for Royal Scholarships and Free Studentships, 1922, just issued by the Board of Education, shows that in Group A (Mechanics) there were fifty-four competitors, and of the nine scholarships and studentships awarded, six are to apprentices in H.M. Dockyard. This is a remarkable testimony to the efficient educational work carried on in the dockyard schools, which all dockyard apprentices must attend for certain specified periods every week. The number of competitors in the other groups of subjects in which scholarships and studentships are awarded were: physics, 17; chemistry, 16; biology, 1; geology, no qualified candidates.

NUMEROUS announcements of courses of technical education for 1922-23 have been received recently. Courses of advanced study and training in research are offered by the Manchester College of Technology in many branches of applied science, including special problems connected with textiles, brewing and allied industries, paper-manufacture, photography, coal-tar, dyestuffs, and india-rubber. The college awards annually a varying number of research scholarships (last year twelve) of 100*l.* each, open to graduates of any university in the British Empire and to other persons suitably qualified. A department of industrial administration has recently been opened. The Sir John Cass Technical Institute of Aldgate, London, invites special attention to its advanced courses (evening) in brewing, micro-biology, petroleum technology, colloids, alternating currents and electrical oscillations, metallography and pyrometry, heat treatment and mechanical testing of metals and alloys, and foundry practice. The Northampton Polytechnic of Clerkenwell, London, has, in addition to its evening courses, day courses in civil, mechanical, including automobile and aeronautical, and electrical engineering, in optical engineering and applied optics, and in horology.

THE Scottish Colleges of Agriculture maintain a close connexion with the regions which they serve by means of their systems of extra-mural work, including lectures and individual instruction, demonstrations and experiments, and advisory work. The Calendar for 1922-23 of the Edinburgh and East of Scotland College mentions a notable development of work in connexion with school gardens which have been laid down under the guidance of the college staff at 196 schools. Seven supplementary school centres are visited by the staff once a week for practical instruction in the school garden combined with theoretical instruction in the laboratory. The Calendar of the North of Scotland College contains an account of the recently opened Rowett Institute for research in animal nutrition, and of an important research which is being conducted by Dr. Rennie in regard to certain diseases of adult bees. In the area served by this college, attendances at county extension classes increased during the past two years from three to eighteen thousand, while attendances at short courses of lectures and single lectures increased from fifteen to thirty-eight thousand. Special schemes are arranged to meet the requirements of the crofting districts in the western seaboard and islands and in Shetland.

## Calendar of Industrial Pioneers.

**November 5, 1800. Jesse Ramsden died.**—Called by Delambre "le plus grand de tous les artistes," Ramsden, by the combination of great scientific ability and practical skill, rose to be the leading instrument maker of his day. Especially valuable was his invention of a dividing machine completed in 1773 after ten years' work. He was born in Halifax, Yorkshire, in 1735, worked first as a cloth worker, and then learned the art of engraving from a London optician.

**November 6, 1913. Sir William Henry Preece died.**—Born in Carnarvon in 1834, Preece, after passing through King's College, London, joined the Electric and International Telegraph Company and eventually became one of the principal telegraph engineers in the country. From 1892 to 1899 he was Engineer-in-Chief and electrician to the Post Office, in which situation he made some of the earliest experiments in wireless signalling and gave valuable support to Marconi. He was twice president of the Institution of Electrical Engineers and was also president of the Institution of Civil Engineers.

**November 8, 1807. Pierre Alexander Laurent Forfait died.**—A distinguished naval constructor whose skill proved of the highest value to the French nation, Forfait first gained a reputation by the building of sailing-vessels for maintaining regular communication between France and America. He was the author of a treatise on the masting of ships and wrote many papers for the Paris Academy of Sciences and the "Encyclopédie Méthodique." He carried out important work at Antwerp and on the Seine, and under Napoleon served in the Ministry of Marine.

**November 8, 1911. William Edward Ayrton died.**—The author of some 150 scientific papers, a prolific inventor, and one of the pioneers of technical education in London, Ayrton served in the Indian Telegraph Service from 1868 to 1872, was professor of physics and telegraphy at the Imperial Engineering College, Tokio, and from 1884 held the chair of physics and electrical engineering at the Central Technical Institution, London. His researches extended to all sides of modern electrical engineering, while among the positions he filled were the presidencies of the Physical Society and the Institution of Electrical Engineers.

**November 11, 1906. John Devonshire Ellis died.**—Trained as an engineer at Birmingham by his father, Ellis in 1854 joined John Brown at the famous Atlas Works at Sheffield, with which he remained connected till his death. He was largely responsible for the manufacture of the armour for our first ironclads, the *Black Prince* and *Warrior*, and was an ardent advocate of the Bessemer process of making steel. He also introduced a method of welding a hard steel face to a wrought-iron backing for the armour of ships. He succeeded Brown as head of the firm in 1879, and in 1889 received the Bessemer medal of the Iron and Steel Institute.

**November 11, 1893. Anthony Reckenzaun died.**—A pioneer of electric traction, Reckenzaun was born at Gratz, Styria, in 1850, and, after being trained as an engineer, worked in England and was engineer to the Electric Power Company. In 1881 he made a trial of an electric car, in 1882 built the launch *Electricity*, and in September 13, 1886, with the *Volta* crossed the Channel, the motive power being obtained from electric cells. He also visited America and applied his system of driving by electric batteries to some cars at Philadelphia. E. C. S.

## Societies and Academies.

LONDON.

**Association of Economic Biologists, October 13.**—Prof. E. B. Poulton, president, in the chair.—E. J. Butler: Virus diseases in plants. The first demonstration that disease can be caused by a filtrable virus was by Iwanowski, in 1892, in mosaic disease of tobacco. Mosaic is now known in nearly 100 species of plants. Diseases like peach-yellows and others characterised by phloem-necrosis are probably caused by similar agents though the filtered juice is not infective. All hitherto tested can be transmitted by grafting, most of them by insects (the chief method in Nature), and many by inoculating with sap. Contact will not cause infection. Infection may be hereditary in the insect transmitter and in the plant. "Carriers" are known. The causal agents are believed to be living organisms. Several investigators have recently found large amoebiform corpuscles or smaller granules in infected cells. The former have been compared with cytotocytes or neurocytes and the latter with Chlamydozoa but a resemblance to Rickettsia is suggested. The causal organisms appear to be obligate parasites.—J. A. Arkwright: Virus diseases in animals and man. The chief points of interest common to plant and animal "virus diseases" are (1) the nature and properties of the virus; (2) the means of transmission, e.g. "carriers" and insect vectors; (3) measures for prevention, e.g. breeding or selection, and isolation or destruction; (4) perhaps the concentration of the virus in certain special tissue cells. About fifty animal virus diseases have been described which may be roughly classified as follows: (1) visible, not filtrable, not cultivated, e.g. Rickettsia; (2) probably visible, filtrable, cultivated, e.g. pleuro-pneumonia of cattle, poliomyelitis; (3) filtrable, not cultivated, some (?) visible in the tissues, e.g. foot and mouth disease, vaccinia; (4) filtrable, very resistant, e.g. infectious anaemia of horses, fowl-pox. In general properties most do not differ much from bacteria, though some are very resistant to drying, glycerine, and heat. The smallest clearly visible and the largest filtrable particles are of the same order of size, i.e. about 0.2 micron. Living organisms may conceivably be much smaller than this. The differentiation of colloidal particles of about 0.2 micron in size by means of the microscope requires attention especially to their arrangement and their range of size and shape, rather than to the appearance of individual particles. Theoretically it is possible that an enzyme may be the cause of an infectious disease on the analogy of Twort's lytic substance and the bacteriophage of d'Herelle.

PARIS.

**Academy of Sciences, October 2.**—M. Albin Haller in the chair.—H. Deslandres: The emission of X-rays, ultra X-rays, and corpuscular rays by the celestial bodies. A summary of previous results on radiations of high frequency and great penetration given by the sun and stars. These radiations form an extremely minute proportion of the total radiation, but their remarkable electrical properties give them an important rôle in the electrical phenomena of atmospheres. Kohlhörster's experiment on the ionisation of gas in a closed vessel at high altitudes (9000 metres) should be repeated at several points on the earth, and extended to the highest possible altitudes attainable by captive balloons. The cost will be considerable, and international co-operation is suggested as desirable.—A. Brachet: The properties of the germinal

localisations of the egg. The eggs of *Rana fusca*, after growth to the advanced blastula stage, were pricked with a needle at various points. From the resulting modifications in the growth it can be concluded that the formative materials of the whole of the central nervous system and the dorsal chord are, in the blastula and consequently in the fertilised egg, localised in the zone occupied by the grey crescent.—**Paul Montel**: Quasi-normal families of meromorphic functions.—**Eligio Perucca**: The surface properties of mercury: voltaic character, surface tension, photo-electric effect. Measurements of the Volta effect and surface tension of mercury in a vacuum and in different gases at varying pressures show changes in both magnitudes which are in qualitative agreement with the anti-contact theory of Frenkel.—**Jean Durand**: Contribution to the study of the thermal modifications of some cast irons. A diagram is given showing the volume expansions and contractions produced in a fragment of cast iron by five successive heatings between 600° C. and 900° C. The swelling of cast iron becomes significant only if the proportion of silicon is sufficiently high and the heating is slow.—**L. J. Simon** and **A. J. A. Guillaumin**: The quantitative determination of carbon and of hydrogen by the use of chromic and sulphuric acids. The carbon is determined directly as usual and the hydrogen indirectly by measuring the amount of oxygen (derived from a weighed amount of potassium bichromate) used in the combustion. Analytical figures are given for ten organic compounds of different types.—**A. Brives** and **M. Dalloni**: The earthquake of August 25, 1922, and the geological structure of the region of Ténès-Cavaignac (Algeria).—**René Souèges**: Embryonic researches on *Hippuris vulgaris*.—**Marc Bridel** and **Mlle. Marie Braecke**: The presence of aucubine and of saccharose in the seeds of *Rhinanthus Crista-Galli*. The biochemical method of Bourquelot applied to *Rhinanthus* seeds indicated the presence of saccharose and aucubine, and both these substances were then isolated from the seeds in a pure state.—**A. Policard**: The mechanism of working of the adipose cells. The elaboration by the mitochondria represents only one of the possible modes of fixing fat; the adult cell takes up the fat by direct fixation without preliminary chemical change.—**A. Desgrez**, **H. Bierry**, and **F. Rathery**: Diabetes,  $\beta$ -oxybutyric acid, and levulose. A study of the conditions under which a certain quantity of levulose may be added with advantage to the diet of diabetic patients.—**A. Goris** and **P. Costy**: Urease and urea in fungi. Urease is present in nearly all the higher fungi. In cases where urease is absent, or present in very small proportion, urea has been found to be present.—**Emile F. Terroine**, **R. Wurmser** and **J. Montané**: The influence of the constitution of the nutritive media on the composition of *Aspergillus niger*.—**Georges Truffaut** and **N. Bezsonoff**: A new bacillus capable of fixing nitrogen. This organism was isolated from some cultures of Versailles garden soil, and morphologically is connected with the Proteus group. This bacillus is aerobic and fixes atmospheric nitrogen. It appears to differ from the bacilli assimilating nitrogen hitherto known, and it is proposed to name it *Bacillus Truffauti*.—**J. Cluzet**, **A. Rochaix**, and **Th. Kofman**: The action of the secondary radiation of X-rays upon micro-organisms.

October 9.—**M. Albin Haller** in the chair.—**H. Douvillé**: The Lepidocyclines and their evolution: a new genus "Amphilepidina."—**E. L. Bouvier**: New researches on the appearance of reproductive individuals in the ants, *Formica rufa*, and *F. pratensis*.—**Paul Vuillemin**: The petalostem.—**G. Bratu**: Progressions of higher order.—**Halvor**

**Hansson**: A new method of multiplication of functional scales.—**M. d'Ocagne**: Remarks on the preceding communication.—**Rodolphe Soreau**: The laws of variation of the characteristics of standard air with altitude.—**M. Seigle**: The possibilities of the commercial use of mild steel bars hardened by extension. Details of the mechanical effects produced in mild steel bars by extension up to the breaking point have been given in an earlier communication. The advantages of this method of hardening are summarised and various possible industrial applications mentioned.—**Charles Nordmann** and **M. Le Morvan**: The effective temperatures of the stars  $\theta$  and  $\iota$  in the Great Bear. Reply to a criticism of Einar Hertzsprung on a previous communication.—**Charles L. R. E. Menger**: The coefficient of Fresnel.—**G. Holst** and **F. Oosterhuis**: The explosive potential of a gas. In Townsend's theory of ionisation by shocks the explosive potential depends only on the properties of the gas, and the material of the electrodes is without effect. The authors have proved experimentally that the nature of the cathode has an important influence. They support the hypothesis that the positive ions do not produce ionisation by contact with the gas molecules, but that by their electrostatic attraction they can liberate them from the cathode. A new theory of explosive potential is outlined, based on this hypothesis.—**Jean Rey**: The probability of illuminating an aeroplane by means of an electric projector.—**André Brochet**: Remarks on the preparation of cyclohexanol. Phenol containing 5 per cent. of its weight of reduced nickel as catalyst is readily reduced to cyclohexanol by hydrogen under pressure in an autoclave. The temperature should be maintained between 100° C. and 150° C. and the pressure kept at 10 to 15 atmospheres. The conversion is quantitative, and no indication was obtained of the formation of any intermediate compound.—**A. Damiens**: The absorption of ethylene by sulphuric acid. The production of ethyl alcohol, diethyl sulphate, and of liquid hydrocarbons. Cuprous oxide dissolved in the strong sulphuric acid proved the best catalyst. On hydrolysis, the acid solution gave different products with varying conditions. Absorption at ordinary temperature, with acid not under 97 per cent., gives ethyl alcohol only, but when a certain concentration of ethylsulphuric acid is reached, ethyl sulphate is also formed. At higher temperatures the velocity of absorption increases, and a considerable quantity of saturated hydrocarbon of the nature of petrol appears among the products of hydrolysis.—**C. Mariller** and **Van Ruymbeke**: A method for the preparation of commercial absolute alcohol and its application to the preparation of a national motor fuel. The vapours from 95 per cent. alcohol pass up a rectification column down which a stream of glycerol is descending. The latter removes water and the distillate contains 98.5-99 per cent. alcohol. The alcohol removed by the glycerol can be readily recovered.—**Raoul Combes** and **Mlle. Denise Kohler**: The disappearance of hydrocarbons in dying leaves. When the leaves die in the autumn, about 45 per cent. of the carbohydrates remain in the fallen leaf and are lost to the tree; 35 per cent. disappear by respiration and only 20 per cent. return to the living parts of the tree and are retained in a form ultimately utilisable.—**St. Jonesco**: The transformation of a chromogen of the yellow flowers of *Medicago falcata* under the action of an oxydase.—**Marcel Mirande**: The relation between anthocyanine and the oxydases.—**Léon Azoulay**: Provoked and spontaneous movements of the leaves of *Russula Queletii* and its varieties.—**P. Mathias**: The evolutive cycle of a holostomid

trematode (*Strigea tarda*).—M. Blanchard and G. Lefrou: A spirouche found in the blood in a case of hæmoglobinuric bilious fever and its pathogenic action.

## Diary of Societies.

### MONDAY, NOVEMBER 6.

- ROYAL INSTITUTION OF GREAT BRITAIN, at 5.—General Meeting.  
 SOCIETY OF ENGINEERS, INC. (at Geological Society), at 5.30.—E. E. Turner: The Atlantic Cruise of H.M. Airship R34.  
 INSTITUTION OF ELECTRICAL ENGINEERS (Informal Meeting), at 7.—F. Gill and others: Discussion on the Importance of Commercial Knowledge to the Engineer.  
 ARISTOTELIAN SOCIETY (at University of London Club, 21 Gower Street), at 8.—Prof. A. N. Whitehead: Uniformity and Contingency (Presidential Address).  
 SOCIETY OF CHEMICAL INDUSTRY (London Section) (at Engineers' Club, 39 Coventry Street, A. 1), at 8.—Dr. E. F. Armstrong: Some Problems in Chemical Industry.  
 ROYAL INSTITUTE OF BRITISH ARCHITECTS, at 8.30.—President's Opening Address.  
 ROYAL SOCIETY OF MEDICINE (Tropical Diseases and Parasitology Section), at 8.30.

### TUESDAY, NOVEMBER 7.

- ROYAL COLLEGE OF PHYSICIANS, at 5.—Dr. R. O. Moon: Philosophy and the Post-Hippocratic School of Medicine. (Fitz-Patrick Lecture).  
 ROYAL SOCIETY OF MEDICINE (Orthopedics Section), at 5.30.  
 MINERALOGICAL SOCIETY, at 5.30.—Anniversary Meeting.—W. A. Richardson: The Frequency-distribution of Igneous Rocks in Relation to Petrogenic Theories.—Miss Naggs: Crystallography of Organic Compounds.—Dr. R. Prior: The Meteoric Iron of Karee Kloof, Cape Province, and the Meteoric Stone of Leucowfontein, Pretoria, S. Africa.  
 ZOOLOGICAL SOCIETY OF LONDON, at 5.30.  
 INSTITUTION OF CIVIL ENGINEERS, at 6.  
 BRITISH PSYCHOLOGICAL SOCIETY (Education Section) (at London Day Training College), at 6.—E. J. G. Bradford: The Synthesis of Geographical Information.  
 INSTITUTION OF AUTOMOBILE ENGINEERS (at Institution of Mechanical Engineers), at 8.—J. D. Moran: High-Tension Ignition.  
 ROYAL PHOTOGRAPHIC SOCIETY OF GREAT BRITAIN, at 8.—W. L. F. Wastell: Presidential Address.  
 ROYAL ANTHROPOLOGICAL INSTITUTE, at 8.15.—Sir Arthur Keith: An Account of Mr. G. Despot's Excavation of the Cave of Ghar Dalani, Malta, and an Exhibit of Two Teeth of Neanderthal Man found there.  
 THE INSTANT SOCIETY (at Institution of Electrical Engineers), at 8.15.—Sir Humphry D. Rolleston: Acute Constitutional Symptoms due to Radiations. (Presidential Address).  
 ROYAL SOCIETY OF MEDICINE (Pathology Section) (in Laboratory of Imperial Cancer Research Fund), at 8.30.—Dr. A. N. Begg: Carcinomatous Infiltration of Nerves.—Dr. A. H. Drew: The Conditions for Growth *in vitro*.—Dr. W. Cramer: Blood Platelets.—Dr. E. R. G. Russell: Intracerebral Tumour Heteroplasty.—Dr. J. A. Murray: Multiple Primary Cancer.

### WEDNESDAY, NOVEMBER 8.

- GEOLOGICAL SOCIETY OF LONDON, at 5.30.—R. D. Oldham: The Earthquake of August 7, 1895, in Northern Italy.—R. D. Oldham: The Pamir Earthquake of February 18, 1911.—Dr. F. Dixey: The Geology of Sierra Leone.  
 ROYAL SOCIETY OF MEDICINE (Surgery: Sub-section of Proctology), at 5.30.—Sir Charles Symonds and others: Discussion on Gonorrhoeal Stricture of the Rectum and its Treatment.  
 INSTITUTION OF ELECTRICAL ENGINEERS (Wireless Section), at 6.—R. L. Smith and R. H. B. Berr: The Effect of Local Conditions on Radio Direction-finding Installations.  
 ROYAL SOCIETY OF ARTS, at 8.—Lord Askwith: The Value of Strikes and Lock-outs.  
 INSTITUTION OF AUTOMOBILE ENGINEERS, at 8.—Major F. Strickland and H. R. Ricardo: The Low Compression, Moderate Speed Engine v. The High Compression, High-speed Engine.

### THURSDAY, NOVEMBER 9.

- ROYAL SOCIETY, at 4.30.—*Probable Papers*.—Prof. H. E. Armstrong: Studies on Enzyme Action. XXIII. Homo- and Hetero-lytic Enzymes.—Prof. A. V. Hill and W. E. L. Brown: The Oxygen-dissociation Curve of Blood and its Thermodynamical Basis.—Dr. H. Hartridge and F. J. W. Roughton: The Velocity with which CO replaces Oxygen from its Combination with Haemoglobin. Parts I and II.—L. T. Hogben: Studies on Internal Secretion. I. The Effect of Pituitary (Anterior Lobe) Injection upon Normal and Thyroidectomised Axolotls.—L. T. Hogben and F. R. Winton: The Pigmentary Effector System. II.—A. Fleming and V. D. Allison: Further Observations on a Bacteriolytic Element found in Tissues and Secretions.

NO. 2766, VOL. 110]

- LONDON MATHEMATICAL SOCIETY (at Royal Astronomical Society) (Annual General Meeting), at 5.—Presidential Address.—H. W. Richmond: The Mathematical Problems of Shell-Flight.—W. R. Burwell: Asymptotic Expansions and generalised Hypergeometric Functions.—W. L. Ferrar: Determinants whose Elements are Determinants.—A. Kerekjártó: Transformation of Variables in a Multiple Integral.—C. Krishnamachari and M. Bhessenanaran: (1) The Properties of Certain Numbers. (2) Contribution to the Evaluation of Persymmetric Determinants.—L. J. Mordell: Trigonometric Series involving Algebraic Numbers.—H. W. Richmond: Analogues of Waring's Problem for Rational Numbers.  
 ROYAL COLLEGE OF PHYSICIANS, at 5.—Dr. R. O. Moon: Philosophy and the Post-Hippocratic School of Medicine. (Fitz-Patrick Lecture).  
 THE WOMEN'S ENGINEERING SOCIETY (at 26 George Street, Hanover Square), at 6.15.—A. P. M. Fleming: Research.  
 OPTICAL SOCIETY (at Imperial College of Science and Technology), at 7.30.—Dr. R. S. Clay: The History of the Photographic Lens.  
 ROYAL SOCIETY OF MEDICINE (Neurology Section), at 8.—Clinical Meeting.  
 INSTITUTE OF METALS (London Section) (at Royal School of Mines), at 8.—Prof. H. C. H. Carpenter: The Production of Large Crystals of Aluminium and some of their Properties.

### FRIDAY, NOVEMBER 10.

- ASSOCIATION OF ECONOMIC BIOLOGISTS (at Imperial College of Science and Technology), at 5.—Dr. E. S. Russell: The Work of the Fisheries Laboratory at Lowestoft.—Sir Sidney F. Harmer: The Present Position of the Whaling Industry.  
 ROYAL ASTRONOMICAL SOCIETY, at 5.  
 ROYAL SOCIETY OF MEDICINE (Clinical Section) at London Hospital), at 5.  
 PHYSICAL SOCIETY OF LONDON (at Imperial College of Science and Technology), at 5.—G. Temple: The Homographic Treatment of the Symmetrical Optical Instrument.—Prof. A. O. Rankine and C. J. Smith: The Structure of the Sulphur Dioxide Molecule.—A. S. Houghton: The Thermal Effect of Vapours on Rubber.—J. T. Robin: Demonstration of an Apparatus for Testing the Tensile Strength of Gas Mantles.  
 INSTITUTION OF MECHANICAL ENGINEERS (Informal Meeting), at 7.  
 JUNIOR INSTITUTION OF ENGINEERS, at 7.30.—A. Macaulay: The Development of Ball and Roller Bearings.  
 ROYAL SOCIETY OF MEDICINE (Ophthalmology Section), at 8.

### SATURDAY, NOVEMBER 11.

- BRITISH PSYCHOLOGICAL SOCIETY (at King's College), at 3.—Miss L. G. Fildes: A Case of Word Deafness.—C. Fox: The Influence of Subjective Preference on Memory.

### PUBLIC LECTURES.

#### SATURDAY, NOVEMBER 4.

- HORNIMAN MUSEUM (Forest Hill), at 3.30.—E. Lovett: The Folklore of the Cat.

#### MONDAY, NOVEMBER 6.

- MIDDLESEX HOSPITAL MEDICAL SCHOOL (in Physiology Lecture Theatre), at 5.—Prof. Swale Vincent: Secretion and Internal Secretion. Succeeding Lectures on November 9, 13, 16, 20, 23, 27, and 30.  
 GRESHAM COLLEGE, at 6.—Sir Frederick Bridge: Music. Succeeding Lectures on November 7, 8, and 10.  
 CITY OF LONDON Y.M.C.A. (186 Aldersgate Street), at 6.—Sir Leonard Rogers: Insects and Disease: Some Triumphs of Medical Science.

#### WEDNESDAY, NOVEMBER 8.

- CHARING CROSS HOSPITAL MEDICAL SCHOOL, at 3.—Sir Arthur Keith: Evolutionary Tendencies in Man's Body (Huxley Lecture).  
 LONDON HOSPITAL MEDICAL SCHOOL, at 4.—Dr. P. Kidd: Forty Years in the History of Tuberculosis (Schorstein Memorial Lecture).  
 UNIVERSITY COLLEGE, at 5.30.—I. C. Grönåhl: Norway. Succeeding Lectures on November 15, 22, 29, and December 6.—At 6.15.—A. W. Flux: The Foreign Exchanges (Newmarket Lectures). Succeeding Lectures on November 15, 22, 29, December 6 and 13.

#### THURSDAY, NOVEMBER 9.

- UNIVERSITY COLLEGE, at 5.15.—Prof. J. E. G. de Montmorency: Customary Law in London and other English City Areas. Succeeding Lectures on November 16, 23, 30, December 7 and 14.—At 5.30.—E. R. Vincent: The Palio di Siena, an Historic Italian Festival.  
 KING'S COLLEGE, at 5.30.—Miss Hilda D. Oakeley: The Stoic Philosophy. Succeeding Lectures on November 16, 23, 30, and December 7.

#### FRIDAY, NOVEMBER 10.

- UNIVERSITY COLLEGE, at 5.15.—Dr. T. E. Gregory: International Exchanges.—C. Tate Regan: Problems of Evolution, with Special Reference to Fishes. Succeeding Lectures on November 17 and 24.  
 BEDFORD COLLEGE FOR WOMEN, at 5.30.—Dr. M. Cary: Ancient Geographical Exploration.

#### SATURDAY, NOVEMBER 11.

- HORNIMAN MUSEUM (Forest Hill), at 3.30.—Dr. W. A. Cunnington: The Natural History of Crabs.

# NATURE

A WEEKLY ILLUSTRATED JOURNAL OF SCIENCE.

*"To the solid ground  
Of Nature trusts the mind which builds for aye."*—WORDSWORTH.

No. 2767, VOL. 110] SATURDAY, NOVEMBER 11, 1922 [PRICE ONE SHILLING

Registered as a Newspaper at the General Post Office.

[All Rights Reserved.]

## BALANCES & WEIGHTS



## REYNOLDS & BRANSON, LTD.

LABORATORY FURNISHERS AND MANUFACTURING CHEMISTS.

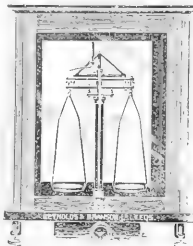

**Balance, Analytical, Rystos**  
New Model. Improved vertical movement of rider hook, rider scale running from end to end of beam and plumb line. The bearings are agate throughout; the beam of hard magnalium. Base of black crystal. Mahogany case with counterpoised front, hinged side doors and sliding back and brass levelling screws. To carry 200 grammes, sensitive to 1th milligramme, or  $\frac{1}{3}$ th milligramme with a less load. ... £14 14 0

*Balances renovated and repaired in our own Workshops.*

For Analytical and other Balances and Weights, see Special Catalogue. Catalogues of Chemical and Physical Apparatus.

Post Free on request.

14 Commercial Street, Leeds.

## SPECTROMETERS

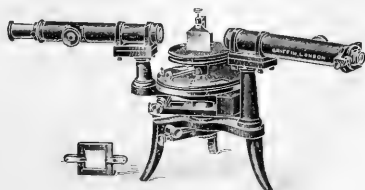

*Particulars and Prices on application to—*

**JOHN J. GRIFFIN & SONS, LTD.**

Kemble Street, Kingsway,  
London, W.C.2.



## HAIR HYGROMETERS

for reading the percentage of moisture. Write for details of our latest patterns. For Laboratories, Cold Stores, Drying Chambers, etc.

**NEGRETTI & ZAMBRA**  
38, HOLBORN VIADUCT, E.C.1.  
LONDON.

## CHRISTMAS SCIENCE COURSE IN SWITZERLAND.

DR. RUDOLF STEINER (Editor of standard editions of Goethe's scientific works), whose lectures at the recent Conference at Oxford opened up new fields of work in Education, will give a course of lectures on

### "THE GENESIS AND SUBSEQUENT DEVELOPMENT OF NATURAL SCIENCE IN THE HISTORY OF THE WORLD"

AT THE

GOETHEANUM, DORNACH, near BASLE,

December 24 to January 6.

For all particulars apply SECRETARY, Goetheanum Science Course, 46 Gloucester Place, London, W.1.

## UNIVERSITY OF LONDON.

A Course of three Lectures in Zoology entitled "PROBLEMS OF EVOLUTION, WITH SPECIAL REFERENCE TO FISHES," will be given with lantern illustrations by MR. C. LATE KEGAN, M.A., F.R.S., Keeper of Zoology in the British Museum (Natural History) at UNIVERSITY COLLEGE, LONDON (Gower Street, W.C.1), on FRIDAYS, November 10, 17, and 24, 1922, at 5.15 P.M. At the first Lecture the Chair will be taken by Professor D. M. S. WATSON, F.R.S., Jodrell Professor of Zoology and Comparative Anatomy in the University. ADMISSION FREE, WITHOUT TICKET.

EDWIN DELLER, Academic Registrar.

## BATTERSEA POLYTECHNIC.

Principal—\* ROBERT H. PICKARD, D.Sc., F.R.S.

University Courses, day and evening, under Recognised Teachers of the University of London are provided in Science, Engineering and Music. CHEMISTRY.—J. KENYON, D.Sc., F.I.C.; J. L. WHITE, D.Sc. PHYSICS.—S. MARSH, B.Sc., Ph.D.; \*A. E. EVANS, B.Sc.; \*J. F. PHILLIPS, B.A., B.Sc. MATHEMATICS.—\*F. M. SAXELBY, M.Sc., B.A.; \*F. W. HARVEY, B.Sc., M.A.; \*W. G. BICKLEY, M.Sc. MECHANICAL AND CIVIL ENGINEERING.—\*W. E. M. CURNOCK, M.Sc., B.Eng.; \*J. B. SHAW, A.R.C.S., Wh.Eng.; \*H. M. EDMONDS, B.Sc.; \*V. G. DAVIES, B.Sc., A.M.I.Mech.E. ELECTRICAL ENGINEERING.—\*A. T. DOVER, M.I.E.E., A.Am.I.E.E.; \*H. C. MANN, A.M.I.E.E. MUSIC.—\*H. D. WETTON, Mus. Doc., F.R.C.O.

\* Denotes recognised teacher of University of London.

There are also:—

Day Technical College in Engineering and Science. Day Training College of Domestic Science. Day Department of Hygiene and Physiology. Day School of Art and Crafts.

Evening Courses in Engineering, Chemistry, Physics, Mathematics, Bacteriology, Chemical Engineering, Hygiene and Physiology, Art, Matriculation Subjects, Domestic Economy, Music, Physical Training. Hostels for Women Students. Large playing fields at Merton.

## COUNTY BOROUGH OF SUNDERLAND.

### PUBLIC LIBRARIES, MUSEUM, AND ART GALLERY.

DEPUTY CURATOR.

The Corporation invite applications for the post of DEPUTY CURATOR. Salary £237 + 10s. per annum.

Applicants must have a knowledge of classification, and be experienced in practical Museum work.

The person appointed will be required to devote the whole of his time to the duties of the office.

Applications, together with copies of three testimonials, endorsed "Deputy Curator," addressed to the CHAIRMAN OF THE LIBRARIES, MUSEUM, AND ART GALLERY COMMITTEE, to be delivered at my office in this hall not later than the first post on Monday, November 20 instant.

Town Hall, Sunderland,  
November 11, 1922.

H. CRAVEN, Town-Clerk.

## THE MANCHESTER MUSEUM.

The Council of the Manchester University invite applications for the post of KEEPER OF THE MUSEUM. Preference will be given to candidates who are University graduates in Natural History subjects. Applications must be sent in before Saturday, December 2. Information as to the duties and stipend of the post will be supplied in response to enquiries to the SECRETARY of the Manchester Museum.

## CHELSEA POLYTECHNIC,

CHELSEA, S.W.3.

Day and Evening Courses in Science under Recognised Teachers of London University.

### I. INDUSTRIAL CHEMISTRY DEPARTMENT.

Technical Courses in Analytical and Manufacturing Chemistry, Pharmacy, Food and Drugs, A.I.C. Courses, Metallurgy, Assaying, Foundry Work, Research.

### II. INDUSTRIAL PHYSICS DEPARTMENT.

Practical work in General Physics, Applications to Industries, Metrology, Calorimetry, Illumination, Acoustics, Electrical Measurement, Research.

### III. BIOLOGICAL AND GEOLOGICAL DEPARTMENT.

Courses for B.Sc., etc., in Botany, Geology, Mineralogy, Zoology. Special Courses in Bio-chemistry, Bio-physics, Bacteriology, Physiology, Hygiene, Entomology, Plant Pathology. Course for Tropical Planters, Research.

SIDNEY SKINNER, M.A.,  
Principal.

Telephone: Kensington 899.

## UNION OF SOUTH AFRICA.

### UNIVERSITY OF THE WITWATERSRAND.

Vacancies for:

#### (A) PROFESSOR OF PHILOSOPHY.

Salary.—£860 per annum on scale £860-30-1100.

Passage.—Allowance of £60 towards passage expenses.

#### (B) LECTURER IN PSYCHOLOGY.

Salary.—£484 per annum on scale £484-26-568.

Passage.—Allowance of £40 towards passage expenses.

In addition, in both cases a free first-class ticket is provided from Cape Town to Johannesburg, and half-salary is paid during the voyage. Duties commence on March 1, 1923.

Applications, together with copies of testimonials as to qualifications, experience, and character, all in duplicate, must be lodged with the SECRETARY, Office of the High Commissioner for the Union of South Africa, Trafalgar Square, W.C., from whom Forms of Application and further particulars may be obtained, not later than November 22, 1922.

## UNIVERSITY OF CAPE TOWN.

### HARRY BOLUS CHAIR OF BOTANY.

Applications are hereby invited for the HARRY BOLUS CHAIR OF BOTANY at the University of Cape Town, which will be vacant from January 1, 1923.

The holder of this chair will be required to take charge of the University laboratories.

The salary is £600 per annum.

The Professor must become a member of the University Teachers' Super-annuation Fund.

Appointments are generally restricted to candidates under 35 years of age, but in the case of a candidate who has been engaged in teaching or in research in South Africa this restriction need not apply.

Applications and copies of testimonials (seven copies) must reach the SECRETARY, office of the High Commissioner for the Union of South Africa, Trafalgar Square, London, from whom forms of application and further particulars may be obtained, not later than December 31, 1922.

The successful applicant will be required to assume duty not later than March 1, 1923.

## KENT EDUCATION COMMITTEE.

### COUNTY SCHOOL FOR GIRLS, BECKENHAM.

WANTED in January, a MISTRESS to help in the teaching of Mathematics, Chemistry, and Physics. Candidates should have obtained either a Pass Degree in those three subjects or an Honours Degree in one of them, with qualifications equivalent to an Intermediate Standard in the other two. Salary will be in accordance with the Provincial Burnham Scale in Secondary Schools.

Immediate application should be made to the HEADMISTRESS.

E. SALTER DAVIES, Director of Education.

## UNIVERSITY OF LONDON, KING'S COLLEGE.

The Delegacy require the services of an ASSISTANT LECTURER in PHYSICS; salary £300 per annum. The duties will commence in January 1923. Opportunities will be given for research work.

Applications, with two copies of not more than three recent testimonials, should be received not later than November 30, by the SECRETARY, King's College, Strand, W.C.2, from whom further particulars may be obtained.

For other Official Advertisements see p. ii of Supplement.



SATURDAY, NOVEMBER 11, 1922.

## CONTENTS.

	PAGE
University Representation in Parliament . . . . .	625
Encephalitis Lethargica . . . . .	626
The Telescope. By Dr. James Weir French . . . . .	627
An Elementary Work on Coal-Mining . . . . .	628
Essays on French Science . . . . .	629
Graphical Methods in Crystallography . . . . .	629
Our Bookshelf . . . . .	630
Letters to the Editor :—	
The Structure of the Red Lithium Line.—Prof T. R. Merton, F. R. S. . . . .	632
The Mechanism of the Cochlea.—Sir W. M. Bayliss, F. R. S.; Dr. W. Perrett . . . . .	632
An Empire Patent.—E. W. Hulme . . . . .	633
Transcription of Russian Names.—Major-Gen. Lord Edward Gleichen; John H. Reynolds . . . . .	635
Volcanic Shower in the N. Atlantic.—Prof. Grenville A. J. Cole, F. R. S. . . . .	635
Orientation of Molecules in a Magnetic Field.—Marshall Holmes . . . . .	635
The Ramsay Memorial in Westminster Abbey. (Illustrated.) By I. M. . . . .	636
S. P. Langley's Pioneer Work in Aviation. By Prof. L. Baird, C. B. E., F. R. S. . . . .	637
The Early History of the Land Flora.—II. By Dr. D. H. Scott, F. R. S. . . . .	638
Obituary :—	
Dr. C. G. Knott, F. R. S. By J. A. E. . . . .	640
Current Topics and Events . . . . .	641
Our Astronomical Column . . . . .	645
Research Items . . . . .	646
The Peril of Milk. By Prof. Henry E. Armstrong . . . . .	648
Indian Institute of Science, Bangalore . . . . .	649
Psycho-Analysis and Education . . . . .	650
Corrosion and Colloids . . . . .	651
Vitamins . . . . .	652
British and American Fine Chemicals . . . . .	653
University and Educational Intelligence . . . . .	653
Calendar of Industrial Pioneers . . . . .	654
Societies and Academies . . . . .	654
Official Publications Received . . . . .	656
Diary of Societies . . . . .	656

Editorial and Publishing Offices:

MACMILLAN &amp; CO., LTD.,

ST. MARTIN'S STREET, LONDON, W.C.2.

Advertisements and business letters should be  
addressed to the Publishers.

Editorial communications to the Editor.

Telegraphic Address: PHUSIS, LONDON

Telephone Number: GERRARD 8830.

NO. 2767, VOL. 110]

## University Representation in Parliament.

THE last General Election was held in December 1918 under conditions entirely unfavourable for testing the revised system of university representation introduced by the Representation of the People Act of that year. Many thousands of the graduates of our universities were, figuratively or literally, removing from their minds and their habiliments the accumulated mud of four years' warfare. Women graduates, enfranchised for the first time both for university and for local constituencies, had been too much occupied with the problems, national as well as domestic, arising from the war, to explore the new opportunities of social and political service which the hardly-won privilege of the vote had gained for them. We need not attempt to examine in detail the political conditions which faced the nation at the conclusion of the war. Personalities and powers chose to act in accord with the transient temperament of a dazed and somewhat irresponsible people, a temperament which we now recognise, after four sobering years, was based on unsound economics and impracticable idealism.

If the lessons of the post-war period have been taken to heart, it is our duty in the present General Election to ensure so far as possible the return of members qualified by natural gifts, by training, by experience, to give to parliament expert and disinterested counsel and to press for measures of reconstruction exhibiting sound and lasting principles. It is from this point of view that we propose to discuss the question of university representation. An old and peculiar element in our electoral system, the principle of university representation was, before the war, the subject of acute political controversy. Threatened with extinction, it has survived powerful and persistent attacks and, for reasons to some extent extraneous to the abstract merits of the case, has emerged from the war with enhanced prestige and extended application.

What then is the history and significance of university representation in parliament? Its originator, James I., was friendly-disposed towards the ancient universities of Oxford and Cambridge and indeed to universities in general, for he confessed that if he were not a king he would wish to be a university man. By letters patent under the Great Seal of England he commanded that two grave and learned men professing the civil law should be chosen by each university to serve as members of the House of Commons. In those days parliamentary representatives were usually chosen in pairs, possibly for mutual succour, and the representation of the ancient universities by two members each has remained undisturbed since the beginning of the seventeenth century. Originally the

enfranchisement of the universities was regarded as "a great favour to the universities as to the prosecuting their affairs in Parliament." This supposed benefit was soon recognised as to some extent illusory, for whereas under the old dispensation members who had been students of the universities "would stand up as occasion offered on behalf of their respective mothers," this duty was relegated to and, it is said, imperfectly discharged by the elected representatives of the universities. Candidly, we should find it difficult to justify the special representation of universities in the House of Commons if its sole object were deemed to be purely institutional, however important as national institutions our universities may be.

In pre-war days Mr. Asquith's complaint against university representation was that any constituency, whether you call it a university or anything else, will in the long run send to the House of Commons a man whose political opinions are in accord with the predominant opinions of those who sent him; and in support of this contention he was able to quote personal examples, particularly the treatment of Sir John Gorst by the University of Cambridge. This argument is not without weight, but it fails to demonstrate that a group of men and women of similar education and a common loyalty does not form as good a constituency for the election of a member of parliament as a group of men and women who happen to live in a selected locality such as South Kensington or East Ham. As Maitland points out, the ancient idea was the representation of communities, of organised bodies of men which, whether boroughs or counties, constantly met as wholes, and enjoyed common rights and duties. That system has given way as regards local constituencies to the representation of numbers, of unwieldy masses of men and women organised only for the purpose of choosing members. But this opens up a wide constitutional question which cannot be treated, adequately and appropriately, in these columns.

We prefer to base the case for university representation on Lord Balfour's argument—that it is a method of getting into the House of Commons, men of science, men of scholarship, men of special and peculiar gifts quite alien from the ordinary working politician. The fact that university representation provides almost the last survival of plural voting enforces this argument. Representation of special interests in parliament may not be, in the abstract, desirable. Like the weather, it has to be accepted as a mysterious fact; and so long as labour, in a narrow sense, co-operation, "the trade," temperance, and many other interests are able to secure their representatives through the ordinary channels, we shall be well advised to implement the traditional method of securing the representation of science and

education and the election to parliament of men and women whose lives have been consecrated, not to the study of the eclectic arts of the politician, but to the pursuit of truth and the advancement of learning. If this thesis be accepted, voters should strive to express in university elections the purpose and ideal which are inherent in this method of election.

### Encephalitis Lethargica.

*Ministry of Health. Reports on Public Health and Medical Subjects, No. 11: Report on Encephalitis Lethargica.* By Allan C. Parsons; with contributions by Dr. A. Salusbury MacNalty and J. R. Perdrau. Pp. x+344. (London: H.M. Stationery Office, 1922.) 10s. net.

THE report on the subject of encephalitis lethargica, recently issued by the Ministry of Health, has a wider than medical interest, as illustrating the still considerable range of disease, of which our knowledge is so partial that preventive action is almost entirely impracticable.

This "new disease" appears to have been first recognised as distinct from other recognised diseases by Von Economo in Vienna in the year 1917. In the early part of 1918 cases were simultaneously reported in Sheffield and London, and prompt action for their investigation was undertaken by the Local Government Board, altogether some 230 cases being recognised during the first six months of that year. The symptoms of this disease, comprising somnolence, from which the patient is roused with difficulty, paralysis of ocular and other muscles, as their most marked features, bore some resemblance to those associated with botulism, and the first task of the earlier investigation was to eliminate the food poisoning to which botulism is due as a cause of the symptoms. This point the earlier official investigations definitely settled. A more difficult question was to decide whether—as was influentially urged—the disease was not a variant of poliomyelitis, which had been recently epidemic, especially among children.

The hypothesis that the two diseases both belonged to what is known as the Heine-Medin group, differing merely in the locality of the nervous lesions, was attractive; but for reasons detailed in the earlier governmental report and confirmed in the present report, this hypothesis, in the opinion of most observers, was satisfactorily eliminated. Similar considerations exclude influenza as a hydra-headed monster, with poliomyelitis and encephalitis lethargica as variants caused by the same virus. In Dr. Parsons' part of the present report the distinctions between these three diseases are judiciously stated. Poliomyelitis prevails chiefly in late summer and autumn, encephal-



lith lethargica in the winter months of December to February inclusive. Poliomyelitis, unlike encephalitis lethargica, attacks chiefly children. Experimentally, the unidentified virus of each disease appears to be a filtrable organism, that of poliomyelitis being readily transmissible to monkeys; that of encephalitis lethargica being transmissible with difficulty and only from acute cases of the disease.

The detailed pathological and bacteriological evidence of the separate identity of these two diseases cannot be given here, but it is set out lucidly in Dr. MacNalty's contribution to the report under review.

The separate identity of influenza is sufficiently indicated by its proverbial infectiousness, whereas multiple cases of either encephalitis lethargica or poliomyelitis are a rarity. Even if it be assumed that the apparent partial non-infectiousness of these two diseases is due to the incarceration of the hypothetical influenzal virus in the deep parts of the central nervous system, it would still need explanation that the virus when introduced in these cases did not cause, *e.g.* in other members of the same family, ordinary attacks of influenza. There is no systematic parallelism in the prevalence of the three diseases; and as Dr. Parsons remarks, "the epidemic behaviour of influenza and encephalitis lethargica do not seem to represent a mutuality of any constant nature." The rarity of respiratory complications in cases of encephalitis lethargica is in itself a strong argument against community of origin.

The present reports by Dr. A. C. Parsons, Dr. A. S. MacNalty, and Dr. J. R. Perdrau, with a prefatory statement by Sir George Newman, bring our knowledge of this disease up-to-date. The value of the report is enhanced by an elaborate bibliography of 1243 items, which will be most useful to students of this obscure subject. The extent of incidence of the disease may be gathered from the statement that in 1919, 541 cases, and in 1920, 890 cases, were recognised and notified, and it is not without significance that cases of poliomyelitis became much fewer in the same period. This may be explained on the supposition that a common virus at different times strikes at different parts of the nervous system; but the totality of evidence, epidemiological, clinical, and pathological, points in another direction.

We began this necessarily sketchy review with a statement that the group of diseases mentioned above do not yet come within the range of practical preventive medicine. When the agitation in one of our chief daily journals in favour of the much-needed Ministry of Health was at its height, the failure of the Local Government Board to control the pandemic of influenza was a big item in the indictment against it. This report, like the recent official report on influenza,

should give pause to those who anticipate that uncontrollable diseases will be made controllable by changing the name of a government department. It has to be confessed—and from a scientific point of view it is most important to face the fact—that "respiratory infections" like influenza and (presumably) poliomyelitis and encephalitis lethargica are almost entirely uncontrollable, and will remain so until some new method of securing immunity is discovered, or until a standard of hygienic precautions is reached in respect of coughing, and even of speaking, which is not likely to be attained universally in this century. Even were it attainable, would life then be tolerable?

Meanwhile, every channel of investigation needs to be pursued; and a word of praise may be given in this connexion to the wisdom of making encephalitis lethargica notifiable in 1918 as soon as its separate existence was fairly well established. By this means it has become practicable to investigate each notified case and to demonstrate the general absence of personal infection from recognised cases. By implication we are led to infer that slight unrecognisable cases of the disease exist which cause its spread; but this fact further emphasises the uncontrollable character of the disease in present circumstances.

Encephalitis lethargica has been described above as a "new disease." This merely means that it is a newly recognised disease. Crookshank and others have searched older literature and found descriptions which tally with this disease, occurring commonly in association with epidemics of influenza; and there can be little doubt that the apparent strict modernity of encephalitis lethargica is indeed apparent and not real.

### The Telescope.

*The Telescope.* By Dr. Louis Bell. Pp. ix+287. (London: McGraw-Hill Publishing Co., Ltd., 1922.) 15s. net.

INVENTION is not the prerogative of the learned. The telescope, we are told, was the creation of the two little children of an observant father, a spectacle-maker of Holland. But, however casual the origin, its development was the result of laborious and progressive experiment and study, an excellent account of which is given by Dr. Louis Bell in the introductory chapter of the work before us.

There are partisans who will dissent from some of the author's historical statements, and many who will object to the presentation of Newton as a "blunderer," a "bungler," and a man who promptly jumped to a conclusion. As a boy, Newton tested the wind by jumping with and against it, and Sir David Brewster remarks: "This mode of jumping to a conclusion, or reaching it *per saltum*, was not the one which our

philosopher afterwards used." Dr. Bell has the same authority for the statement that, when investigating the relationship of dispersion to mean refraction, Newton mixed sugar of lead with the water. Traced to its source, however, this so-called fact appears to be merely a suggestion of Mr. Michell, a friend of Dr. Priestley, offered as an explanation of an otherwise inexplicable experimental result and based on Newton's use of *saccharum saturni* in other experiments.

Flint glass good enough for quantitative observation could scarcely have existed in 1666, for about a hundred and forty years elapsed before Guinand resolved the optical glass problem. It was more the absence of suitable material that "delayed the production of the achromatic telescope by some three-quarters of a century" than any action of Newton. Indeed, Sir Isaac Newton should be honoured for his prescience in recognising that in the circumstances the practice of astronomy could best be advanced by the development of the reflector.

"The Telescope" has been "written for the many observers who use telescopes for study or pleasure and desire more information about their construction and properties," the information hitherto published on the subject being "for the most part scattered through papers in three or four languages and quite inaccessible to the ordinary reader." Within the limits of a single volume the author has collected a great deal of essential information that the general reader will find both useful and interesting.

Following the historical introduction there are chapters on the modern telescope, optical glass and its working, properties of objectives and mirrors, mountings; eyepieces, hand telescopes and binoculars, accessories, the testing and care of telescopes, setting up and housing, seeing and magnification, and finally, a brief appendix on work for the telescope.

The book is not free from mistakes. In the description, for example, of the Galilean glass, the field is stated to be approximately measured by the angle subtended at the centre of the objective by the pupil. The description given in "The Telescope" by Herschel, although theoretically incomplete, might have been copied with advantage, as it explains how the field is determined by the diameter of the objective and the possible displacement of the eye. In chapter 7 the so-called Dove prism system is described as the rudiment of the prism binocular or shortened telescope. Such a system, unlike the earlier Porro combination, cannot be placed in the convergent beam and it cannot serve to shorten the telescope.

Those to whom style and composition are of importance will regret the inelegance of such expressions as "credulous twaddle," "pricked up its ears," and

"blast of hot air." Their use detracts from the pleasure of perusal of a welcome addition to the literature of the telescope. JAMES WEIR FRENCH.

### An Elementary Work on Coal-Mining.

*An Elementary Text-Book of Coal-Mining.* By Robert Peel. Revised and enlarged by Prof. Daniel Burns. Twentieth edition. Pp. viii+420. (London and Glasgow: Blackie and Son, Ltd., 1922.) 6s. net.

THIS little book is, as its title expresses, a book dealing with the most elementary principles of coal-mining. It has obviously answered its purpose extremely well, and has suited the needs of those to whom it is particularly addressed, as is only too evident from the fact that it has reached its twentieth edition since its original publication twenty-nine years ago. It need scarcely be said, therefore, that the general arrangement and style of the work are beyond criticism, otherwise it would not have survived the rigorous test of experience through which it has passed. Any review of the work must therefore be based upon the nature of the revision to which it has been subjected.

It may fairly be said that the labour of revising such a work falls under three main heads, namely, first to eliminate all possible blunders; secondly, to bring the work thoroughly up-to-date, and thirdly, to see that there is no ambiguity likely to puzzle the student. Unfortunately, it cannot be said that the revision stands the test under any of these three heads, and a couple of illustrative examples of shortcomings may be quoted under each. There are, for example, blunders in spelling, such as "Plainmeller" for "Plenmeller" and "Maudline" for "Maudlin." Under the second heading we have such statements as that the deepest borehole in the world is that at Schladebach, which attained the depth of 956 fathoms. This was true once, but the deepest borehole in the world to-day is that at Czuchow, Rybnik, Upper Silesia, which has attained a depth of 7350 feet. Again, the statement that of centrifugal fans those most generally adopted are the Guibal, Waddle, and Schiele was true once, but is not true to-day. The only reference given to the Kind-Chaudron method of sinking in this country is its first application at Marsden, the far more important, instructive, and recent sinking at Dover not being mentioned. Under the third head we get such a statement as that when it is inconvenient to state work in foot-pounds as the unit of work a higher unit is adopted termed horse-power. The confusion between work and power, to which most students are prone, is one that should never be allowed to creep into a text-book, where the difference between the two standards should be very clearly explained. Again, in dealing with the thickness of tubing, two

formulas are given, one due to Greenwell and the other to Aldis; an example is given of the use of the former, which is here worked out, giving a thickness of 1.19 inches; if the reviser had worked out the same example by the second formula here given, he would have obtained a thickness of 1.98 inches, yet no hint is given to tell the student that the two formulas do not agree, or to help him in any way to reconcile so grave a discrepancy.

It is also a pity that so many of the illustrations are mere sketches, and badly executed at that. As an example Fig. 104, which is intended to be the plan of a horizontal winding engine, may be quoted; an intelligent boy of twelve who had seen a winding engine would probably in his drawing indicate that there are such things as valves and valve-rods.

It has been thought advisable to direct attention to the points in which this little book falls short of the standard to which it might so easily be raised, because, as already stated, it has evidently a very decided sphere of usefulness, and in a work of this kind addressed to the beginner it is pre-eminently necessary that he shall receive no wrong impressions and shall be left with nothing to unlearn when he advances to the higher stages of the subject.

### Essays on French Science.

*Discours et mélanges.* Par Émile Picard. Pp. v+292. (Paris: Gauthier-Villars, 1922.) 10 francs.

THIS volume contains discourses, short essays, and obituary notices of some distinguished French men of science. It may be warmly recommended, more especially on account of the obituary notices, which do not confine themselves—as is too frequently the case—with an account of the work done, but tell us something of early surroundings, education, and temperament, and thus bring out the personality as well as the results achieved. It is not only that the account gains in interest thereby, but the information allows us to judge more adequately of the individual influence exerted on contemporary science.

Pierre Duhem's work is recognised in this country by every one familiar with thermodynamics, but the personal touches which M. Picard's account supplies give us just what is wanted to appreciate the full value of the man. Poincaré is better known to us, perhaps Darboux also, but we shall find here something new about them as well as about others with whose work M. Picard deals. The notice of Lord Kelvin is excellent.

The author does not always confine himself to those branches of science which he has himself enriched by valuable contributions. As secretary of the Academy of Sciences he has to undertake the duty of explaining the ground for the award of prizes, some of which. Like

that founded by Mr. Osiris, include a wide range of subjects. We thus find short discourses on "French Aviation in 1909," and even on "Antityphoid Vaccination." A lecture on the diminution in the birth-rate was no doubt inspired by the atmosphere of the war, and some of the other writings are even a more direct outcome of the anxieties of the time at which they were written. Here it is perhaps allowable to make one criticism. In the essay on "Les Sciences mathématiques en France," M. Picard shows so much knowledge of scientific history in other countries and such fair appreciation of the international aspect of science, that one regrets the inclusion of an article that originally appeared in the *Revue des Deux Mondes*: "L'histoire des sciences et les prétentions de la science allemande." There is no doubt much in it that is true, but it is not written in the dispassionate and eminently fair spirit which pervades the rest of the book and it strikes a discordant note.

### Graphical Methods in Crystallography.

*Graphical and Tabular Methods in Crystallography as the Foundation of a New System of Practice: With a Multiple Tangent Table and a 5-Figure Table of Natural Cotangents.* By T. V. Barker. Pp. xvi+152. (London: T. Murby and Co., 1922.) 14s. net.

IT has been anticipated for some time that Mr. Barker would publish an account of the graphical and tabular methods in crystallography which he has been teaching at Oxford, and that his book would include a description of the form of two-circle goniometry and its special application to crystallochemical analysis, which he recommends as the result of his studies in Russia under the late Prof. Fedorov. The present volume only very partially fulfils these expectations, crystallochemical analysis being reserved for a further publication. So far as it goes, however, the book is a valuable presentation of extant graphical methods, and it concludes with a most useful table of multiple tangents.

The main purposes of the monograph are "to provide the researcher with a select collection of exact graphical methods, which personal experience has proved to be both accurate and time-saving; to discuss the relation of these methods to formal processes of computation; and, finally, to outline a new system of practice." The methods described involve the use of both the stereographic and gnomonic projections, and are a mixture of the well-known ones due to Penfield, Hutchinson, V. Goldschmidt, and Fedorov. A crystallographic protractor is described and recommended, which in itself is a happy combination of the features of the Penfield, Fedorov, and Hutchinson protractors.

The new system of practice, which forms the subject of the last chapter, is obviously chiefly concerned with rapid (time-saving) work, with a view to the inclusion of some crystallographical account of all new substances, as well as existing ones, in a comprehensive catalogue, or to the identification of a crystallised substance by the comparison of such rapidly acquired data with that contained in such a compendium of measured substances. Two-circle methods are used, and the table of angles characteristic of a substance consists of the theodolitic  $\phi$  azimuth and  $\rho$  altitude values. It is suggested that "two, or at most three, crystals be measured," that "the indices be determined by a time-saving method," that "the mean observed angles be published without any citation of limits," and that "the practice of computing theoretical angular values (apart from those involved in the elements) be discontinued." This may satisfy Mr. Barker, and may possibly be adequate for the particular purpose which he has in view. But it is most sincerely to be hoped that serious crystallographic research is not to be so circumscribed, and that absolute accuracy will be placed before time-saving. Otherwise we shall rapidly revert to former chaos. It has been, indeed, only by the most accurate and laborious work, in which time was regarded as subservient to the highest accuracy, that the subject has been brought to its present high position; this alone has rendered possible the wonderful confirmation, by the absolute measurements now made by the Bragg X-ray spectrometric method, of the work of the later crystallographers.

### Our Bookshelf.

*Magnetism and Electricity.* By J. Paley Yorke. New edition, completely rewritten. Pp. viii + 248. (London: E. Arnold and Co., 1922.) 5s. net.

WRITTEN in colloquial language, this book, which is a first-year course on magnetism and electricity, will appeal to many beginners besides the students in technical institutions, for whom it is primarily intended. "These students have one great quality: they are out to learn and to understand, and as they are not hampered by the immediate necessity of cramming for any particular examination, are able to enjoy the pleasures of understanding instead of suffering the terrors of memorising. . . . Memory is useful for examinees, but understanding is essential for engineers." There is abundant evidence throughout these pages that the author is familiar with the difficulties met with by the beginner, and he is always careful to explain the technical terms which are apt to be used freely by text-book writers who have almost forgotten that their jargon is not that of the man in the street. Magnetism is first dealt with, and then the ideas of static and current electricity are introduced. The author is particularly successful in developing the self-contained water circuit analogy, the basic idea

of which is that energy can be distributed without any consumption of the water. Experience has convinced him that the plan of introducing the measurement of electrical energy at an early stage is very effective. The basic ideas of electro-magnetic induction are discussed in some detail, and in the final chapters the phenomena of electrostatics are briefly treated. We can recommend the book to those for whom it is intended, but fear to think what the modern relativist would have to say to such statements as, "Anything which has weight is called *Matter*: magnetism is therefore not matter" (page 21); "This something which is called energy has not got weight" (page 57)!

*The Climates of the Continents.* By W. G. Kendrew. Pp. xvi + 387. (Oxford: Clarendon Press, 1922.) 21s. net.

MR. KENDREW strikes new ground by giving a description of the actual climates of the regions of the world. The scope of the treatment must naturally vary with the nature of the original sources which are available, but no detailed local descriptions are attempted. A general knowledge of meteorology is assumed. There is no explanation of the omission of polar climates, north and south. Quite enough is now known of these climates to enable useful accounts to be included in a book of this sort. The oversight mars the usefulness of the volume. We notice that Mr. Kendrew adheres to the idea that the heating of north-west India furnishes an explanation of the south-west monsoon. The comparatively poor rainfall in the north-west he attributes to the previous course of the winds reaching that region, which has deprived them of much of their moisture. According to Dr. G. C. Simpson, the explanation is far more complex, and depends on several factors, of which one of importance is the dry upper-air current from the west, which prevents cloud formation in the ascending air. These and other recent theories regarding the monsoon are not discussed by Mr. Kendrew. There are many clear diagrams and maps, and numerous meteorological data. All students of geography will be grateful for this well-arranged and lucidly written volume.

*Miracles and the New Psychology: A Study in the Healing Miracles of the New Testament.* By E. R. Micklem. Pp. 143. (London: Oxford University Press, 1922.) 7s. 6d. net.

THIS work is concerned with a comparison between the healing miracles described in the New Testament and the case records of modern psychotherapy chiefly drawn from war practice. A brief description of modern psychotherapeutic measures is given, but the complexity and difficulty of the subject almost necessarily makes such a sketch confusing to the uninitiated reader. The sources of the New Testament narratives are examined and the inexactitude of observation is commented upon, especially in the fourth gospel. The current superstitions anent the relationship of sin and disease and demonology are noticed as likely to colour and detract still further from the trustworthiness of the descriptions.

The miracles are then dealt with *seriatim*, and where possible, recent parallel cases are quoted. Finally, the author disclaims the belief that all the subjects of the

healing miracles were suffering from what would now be called functional disease, but seeks to support his thesis that these works of Christ were in accordance with natural laws, by quoting cases (not always convincing) of the effect of psychotherapy on organic disease.

The general impression of the book is that while the author has made out a plausible and even probable argument that the miracles were not supernatural phenomena, his parallels are not sufficiently exact to carry absolute conviction. Such exactitude could never be obtained in view of the unscientific observations of the New Testament cases by men who certainly thought these works were supernatural and were quite untrained in medical knowledge. As the author points out, even Luke "the physician" uses terms rather less exact from the medical point of view than do the others. The book is certainly readable and interesting, but belief that the ministrations referred to in it were miraculous is not likely to be disturbed by the author's scientific consideration of the evidence upon which it is based.

*A Book about Sweden.* Pp. 183. (Stockholm: A.-B. Nordiska Bokhandeln, 1922.) n.p.

WE have received through the Swedish Consulate-general in London a copy of "A Book about Sweden," published in Stockholm by the Swedish Traffic Association. It is a compact guide, very fully illustrated, written in English for those who may wish to visit Sweden, or for those who have not yet realised what a charming and novel field awaits the tourist, accustomed to think of Europe as centred in Grindelwald or Assisi. The photograph of the s.s. *Saga*, now running between London and Gothenburg (Göteborg), invites the Englishman by a reminder of his Viking blood. The description of the country and its human occupations is geographical, and many of the views, such as those in Lappland, are difficult to obtain from other sources. That of the iron-mountain of Kiruna, lit up electrically for work in the long winter night, illustrates one of the great romances of Swedish industry. The account of power-developments in general will interest scientific readers. We are shown the fascination of Abisko, remote within the Arctic Circle; but nothing is said about the summer mosquitoes, and the happy tourists at Torneträsk seem to be going about unveiled. The manifold charm of Stockholm, a city unlike any city, the sweet clean beauty of the forest country, the rush of waters at Porjus and Trollhättan, are here simply set before us. If one knows Sweden already, it is all the more delightful to turn these pages, and, as the Dalarna poem says, to long for her again. This little handbook may be recommended to British teachers of geography.

G. A. J. C.

*14,000 Miles through the Air.* By Sir Ross Smith. Pp. xii + 136. (London: Macmillan and Co., Ltd., 1922.) 10s. 6d. net.

THIS small volume by the late Sir Ross Smith marks an epoch in the history of flying, for it is a record of the first flight from London to Australia. Sir Ross Smith and his brother, Sir Keith Smith, accompanied by two air-mechanics, Sergeants J. M. Bennett and W. H. Shiers, entered a Vickers-Vimy aeroplane for

the prize of 10,000l. offered by the Commonwealth Government in 1919 for a flight from England to Australia in 30 days. As is well known, the two brothers won the race. They left Hounslow on November 12, 1919, and reached Darwin on December 10, 1919. From there the flight was continued to Sydney, Melbourne, and Adelaide. The actual time spent in flying between London and Adelaide was 188 hours 20 minutes. The longest spells in the air were 730 miles from Bundar Abbas to Karachi, and 720 miles from Karachi to Delhi. The brevity of the book makes it all the more vivid, and helps the reader to realise the speed of travelling by air. The author gives few incidents and certainly dwells lightly on the difficulties encountered. But there are some exciting passages, of which one of the best is the flight through the clouds between Rangoon and Bangkok, and the groping descent with the fear of collision with the heights of the Tenasserim Ranges. The book is well illustrated, the pictures of cities taken from the air being very striking. It is much to be regretted that this high-spirited airman lost his life at the very start of his next great adventure, a few years later, of the flight round the world.

*Evolutionary Naturalism.* By Prof. R. W. Sellars. Pp. xiv + 349. (Chicago and London: The Open Court Publishing Co., 1922.) n.p.

THE author of this book is one of the "critical" realists. The difference between a neo-realist and a critical realist would seem to be that the former regards the datum of perception as identical with the object of knowledge, while the latter distinguishes between them. The neo-realist says that we know the physical existence in perceiving it, the critical realist says we know the existence of the physical thing but what we perceive is its essence. Objects exist, but only their content and not their existence is perceived. The special theory which Prof. Sellars names evolutionary naturalism is based on this distinction. Its two great enemies, we are told, are Platonism and Kantianism, both of which are supernaturalistic. The theory is worked out in laborious detail and applied to the different problems of philosophy.

*Greek Biology and Greek Medicine.* By Dr. Charles Singer. (Chapters in the History of Science, I.) Pp. 128. (Oxford: Clarendon Press, 1922.) 2s. 6d. net.

DR. SINGER here gives a succinct account of the general evolution of Greek biological and medical knowledge. The biological portion of the book is arranged in three sections, "Before Aristotle" (18 pp.), "Aristotle" (36 pp.), and "After Aristotle" (24 pp.); the remaining 50 pp. being allotted to Greek medicine. The section on Aristotle appears here for the first time; the others are reprinted, with slight amendments, from "The Legacy of Greece." All who are interested in the biological sciences will be glad to have in this cheap and convenient little volume an authoritative account of the works of Aristotle, Galen, Hippocrates, and others who laid the foundations of the science of life; and the majority of readers will be amazed at the extent of our indebtedness to Greece.

### Letters to the Editor.

[The Editor does not hold himself responsible for opinions expressed by his correspondents. Neither can he undertake to return, or to correspond with the writers of, rejected manuscripts intended for this or any other part of NATURE. No notice is taken of anonymous communications.]

#### The Structure of the Red Lithium Line.

In a recent number of the Proceedings of the Royal Society Prof. McLennan and Mr. Ainslie have announced the interesting discovery of a new component of the line  $\lambda = 6708$  in the spectrum of lithium, the line appearing, under the conditions of excitation employed by them, as a quartet. They proceed to discuss the possibility of this structure being due to two pairs of lines, each pair being assigned to one of the isotopes of lithium. To the present writer it appears that the new components cannot be accounted for in this manner.

The structure of the line in question has been investigated by Kent (*Astrophys. Journ.* vol. 40, p. 337, 1914), Takamine and Yamada (*Proc. Tokio Math. Phys. Soc.*, vol. 7, No. 18, p. 339, 1914), Zeeman (*Proc. Roy. Acad. Amsterdam*, p. 1130, Feb. 1913; p. 155, Sept. 1913), King (*Astrophys. Journ.*, vol. 44, p. 169, 1916), and the writer (*Proc. Roy. Soc. A*, vol. 99, p. 101, 1921). Kent, and Takamine and Yamada, observed it as a single pair of emission lines, and Zeeman, who investigated the absorption spectrum, also recorded a single pair of lines, with the reservation that with a high density of the absorbing vapour other lines made their appearance. Zeeman considered that these lines which appeared at high vapour densities were analogous to lines observed in the sodium spectrum by R. W. Wood. King, who investigated the structure of the line in the arc and in the tube-furnace, found that with a low vapour density the line appeared as a simple pair, and that at higher vapour densities a third component appeared; with a still greater amount of vapour the phenomena were complicated by reversal. King has published one photograph in which, owing to reversal, the line has the appearance of a quartet. McLennan and Ainslie used a vacuum arc under conditions in which it would appear that the density of the lithium vapour must have been very great, and one may surmise that this condition is essential for the appearance of the fourth component.

It seems, however, that under appropriate conditions the line appears as a simple pair, and our ideas as to the nature of isotopes would have to be profoundly modified if the pairs due to the two isotopes were found to require different conditions for their excitation. If the four components were really two pairs due to the two isotopes they should always appear together with an invariable intensity ratio of 1:16. The line can be seen easily as a simple pair in a carbon arc in air if the poles are brushed over with an exceedingly dilute solution of a lithium salt. The components are then less sharp than when the vacuum arc is used, and the main difficulty is to have little enough lithium in the arc, so as to avoid the appearance of the third component and complex structures due to reversal. In the vacuum arc the third component appears very readily unless the amount of lithium vapour is small. It may further be mentioned that the relative intensities of the components are not in good accordance with the view that they are due to the two isotopes.

From a theoretical point of view also, there are grave difficulties. The calculated separation, on

Bohr's theory, of corresponding lines in the pair, is about 0.087Å., the observed separation being between three and four times as great. McLennan and Ainslie put forward the suggestion that the separation may in fact be the product of the "calculated separation" and the atomic number; but the correctness of the calculated separation has been verified by the observed differences between the lines of the Balmer series of hydrogen and alternate members of the  $\zeta$  Puppis series of helium, and in this case the agreement is exact and the "calculated separation" does not require to be multiplied by a factor of 2, the atomic number of helium.

T. R. MERTON.  
The Clarendon Laboratory, Oxford,  
October 19.

#### The Mechanism of the Cochlea.

IN view of the discussion in these columns towards the end of 1918, and the letters which followed it at various times, the model designed by Mr. George Wilkinson, of Sheffield, and described in *NATURE* of October 21, p. 559, is of much interest and importance. It is obvious that the construction of such a model presented many mechanical difficulties, and great credit is due to Mr. C. E. Stewart, the mechanician of Prof. Leathes's laboratory, for the successful result. It may, therefore, be useful to mention that a full description was published in the *Journal of Laryngology and Otology*, of September last, a short account having been given in the Proceedings of the Physiological Society (*Journal of Physiology*, vol. 56, p. ii). The apparatus was demonstrated to the Physiological Society in December 1921, as also to the British Association in September 1922.

I take it that others besides medical students have been dissatisfied with most of the theories put forward to avoid the difficulties thought to be involved in the Helmholtz view of the resonance of the basilar membrane. Those theories in which this membrane is supposed to act as a whole, like a telephone diaphragm, or by "pressure patterns," are inconsistent with the progressive differentiation of structure along the membrane, in addition to being in conflict with what is known of the conducting properties of nerve fibres. Thus the views suggested by Ewald, Rutherford, Waller, and Wrightson are unacceptable. It appears that although Helmholtz had referred incidentally to "loading" of the vibrating elements of the membrane by the liquid in which it lies, the great importance of this factor was first realised by Mr. Wilkinson and investigated experimentally by him. His model is doubtless capable of still further improvement, but even in its present form many problems would have light thrown upon them by its behaviour. The degree of damping and the spread of resonance to neighbouring elements may be mentioned. The number of waves required to excite sympathetic resonance of a tuned element may perhaps be determined. Some degree of spread is not inconsistent with the Helmholtz theory, since the amplitude of vibration of other elements than those in tune with the vibrations received might well be too small to stimulate the nerve endings. Dr. Gray has shown that a similar cutting out of small stimuli takes place in the localisation of a point of pressure in the skin.

It is of interest to note that the model responds to a tuning-fork held in contact with the brass case, just as the cochlea does to conduction through bone. This indicates that the impulses given by the movements of the stapes are the same as those of sound waves directly transmitted through water, as would be expected from theoretical considerations.

Mr. Wilkinson also points out in his paper the necessity for the basilar membrane being continuous. If the fibres had gaps between them, no regular loading of the vibrating elements would be possible.

W. M. BAYLISS.

University of London, University College,  
Gower Street, W.C.1.

THE description of Dr. Wilkinson's model of the cochlea in NATURE (October 21, p. 559) recalls Dr. Yoshii's experiments on guinea-pigs. Yoshii operated with long-sustained notes from whistles of different pitches, and concluded from the resulting lesions in the organ of Corti that the pitch of the note determines the region of maximal displacement of the basilar membrane. But as he used the same pressure to blow the different whistles (*Zeitschr. f. Ohrenheilkunde*, 58, 1909, p. 205), the product  $a^2n^2$  had a constant value, *i.e.* the greater the frequency of the note employed, the less the amplitude of its vibrations, which shows at once that Yoshii's results do not support his conclusions. If Dr. Wilkinson's model of the cochlea is a good one, it will show that the locus of maximal vibration in the basilar membrane for a given note shifts toward the distal end when the intensity of that note is increased, and toward the fenestral end when its intensity is diminished; and will thus demonstrate once again that the principle of resonance can find no application in the internal ear.

W. PERRETT.

University of London, University College,  
Gower Street, W.C.1,  
October 26.

### An Empire Patent.

IN the article appearing in NATURE for September 30, p. 437, with the above heading, there is the underlying assumption that the status of the inventor should be assimilated to that of the author, namely, that both should be secured a world-wide monopoly at a minimum expenditure. Will you allow me to present in your columns a more philosophical view of the history and function of patent law in relation to the growth and decay of civilisation, from which it will be seen that the favourable treatment of the inventor cannot be based upon international principles. It is part and parcel of a purely national and competitive policy.

The processes by which the characteristics of a higher civilisation are transmitted to races of lower culture appear to be based ultimately upon biological laws. Pressure generated within the walls of the higher civilisation drives out its more enterprising citizens to seek their fortunes elsewhere, and the new colonists, by interbreeding with the native stock, impart to it their own superior characteristics. The outward forces tending to the disruption of the older organisation may be economic, religious, or political, or some combination of these. The process may occupy centuries or be accomplished within as many decades. Thus the industrialisation of the English occupied many centuries—the periods of advance in the reigns of Edward III., Elizabeth, and Charles II. being associated with large influxes of the industrial population of the Continent. On the other hand, the rapid rise of the United States to the rank of a first-class power has been the work of the past fifty years. In both these instances national development was preceded by conditions which favoured the introduction and assimilation of a higher strain from abroad. Maintaining a civilisation at a high level in

turn rests upon its compliance with the same biological law.

Talent and enterprise are the natural monopoly of a relatively small fraction of the human race. These characteristics are transmitted by direct descent, reproducing themselves in successive generations. How closely the fortunes of an industry may be associated with particular family names—notwithstanding the dilution which each family undergoes by marriage—is not sufficiently recognised. It has, for example, been shown recently that iron founding was introduced into this country by a body of French workers in the reign of Henry VII. A leading family which came in at this period were the Leonards, members of which migrated to the United States in the seventeenth century; whence the saying arose, that "where you find ironworks there you find a Leonard." But there is some reason to suppose that the French iron-founders originally came from Italy. Hence the Leonardos, Lennards, or Leonards may trace their connexion with this industry perhaps for 500 years. This reappearance of the same characteristics in successive generations of a family, and the predominance of the imported families in the higher ranks of culture—other than that of administration—can be verified by reference to the National Directories. A Stirling is generally an engineer, a Hochstetter a mineralogist, a Matthiessen a physicist. These families form a cosmopolitan body whose services can be enlisted by any country which possesses the power and foresight to attract them. Thus the maintenance of a civilisation depends upon its power to retain the services of its best native stock, while constantly reinforcing it from outside sources.

At an early period in the history of this country, bringing in companies of skilled artisans from abroad became an accepted feature in the exercise of the Royal prerogative. In the reign of Elizabeth a new feature was introduced, whereby, in addition to the Royal protection and favour, an exclusive right of manufacture was granted to any institutor of a manufacture not in use within the realm at the date of the Letters Patent. This system, though opposed to the tenets of the Common Law, received a grudging recognition in the Statute of Monopolies in 1624. Under this Statute the rights of the native inventor rested on the fact of his profession that he was willing and able to institute a new industry. The efficacy of the law rested upon two principles: that it attracted foreign strains of inventive ability, while stimulating that of the native inventor. Anthropologists are agreed that there is a fairly equal distribution of ability in different races. The English Crown recognised the deficiency in native stock and made good its defects by selective racial interbreeding.

The first blow to the efficiency of the English patent system was struck in the last quarter of the eighteenth century by a judge of the King's Bench. It is well known that there is a remarkable hiatus in the continuity of patent law decisions for the century and a half subsequent to the Statute of Monopolies. The reason for this is now clear. The Crown, notwithstanding the provisions of the above Statute, successfully maintained the right of disposing of its own grants by constituting the Privy Council the Court before which alone the validity of patent rights could be adjudicated. In spite of the more than doubtful character of its jurisdiction, the Council proved a most competent and business-like tribunal. It never lost sight of the real object of the law. Hence proposals for instituting new industries were not allowed to drop if a suitable applicant for the

privilege was forthcoming. The rights of the native workman were carefully respected. Occasionally technical points of law were reserved to the Common Law Courts, and in exceptional cases parties were allowed to seek their legal remedy; but in only one doubtful case during this period has any decision of the Courts found its way into patent jurisprudence.

With the Hanoverian dynasty the zeal of the Council in prosecuting its industrial policy sensibly abated, and about 1750, after an unseemly squabble between Lord Mansfield and the Privy Council, the jurisdiction of the Council was allowed to lapse. Thus when the Common Law Courts resumed their jurisdiction over Letters Patent they were without precedent to guide them for a period of about a century and a half.

It was in these circumstances that the well-known doctrine of the patent specification was evolved. Interpreting the Statute of Monopolies by the contemporary meaning of its language, the Courts construed the phrase "true and first inventor" in its modern sense. This left the Statute devoid of any expressed consideration; for it invested the inventor with rights without any corresponding obligation. True there was a clause in the Letters Patent of recent introduction which made the validity of a patent contingent upon the filing of a specification within a fixed period, but there was also an older final clause waiving a full, or indeed any, disclosure. By emphasising the former and ignoring the latter clause, Lord Mansfield laid down that the patent grant was made in consideration of the filing by the patentee of such a description of his invention as would enable a skilled artisan in the trade to work the invention. The effect of this judgment was to make the validity of patents conditional upon their compliance with an uneconomic and, from an administrative point of view, impracticable standard of novelty; for the decision involved the shifting of novelty from the practice of the trade to novelty of disclosure within the realm. By depreciating the security of the patent it lowered its commercial value—while discouraging the importation of industries not practised within the realm. As, however, no attempt was made to bring administrative practice into harmony with the legal requirements, applicants continued to obtain their patents on the old basis.

In 1905 a fifty years' search through British patent specifications came into operation. It was instituted as an instalment of a wider scheme of examination to be introduced at a future date. The effect of official examination is always to reduce the restraining power of a monopoly in a degree corresponding with the extent of the search. A representative of one of the largest patent-owning firms in the United States once said to the present writer, "Our American patents are not worth a d—n! We take them out because they are cheap!" Without applying this dictum wholesale as a criterion of the value of the patents issued by any office which examines for novelty, it is clear that the effect of official examination is to reduce a large proportion of its grants to the level of commercial advertisement. If it be alleged that the object of the above measure was to harmonise the law and practice of patents, it must be pointed out that the framers of this Act introduced at the last moment a clause to "round off" the official search by removing British patent specifications not retained on or included in the official files from the stock of public knowledge. Thus the Common Law standard was sacrificed to official convenience. In this manner the English Law of Novelty has been made to box the compass. Valid patents can now be obtained without any consideration, for the disclosure may be

identical with that already disclosed and published. The latter cannot be cited as evidence of prior anticipation. Let it be granted that no public inconvenience has arisen under the operation of this clause: but this admission undercuts the whole case for official examination so far as that examination is conducted through specifications of lapsed patents. The law obviously stands in need of a clear and business-like statement of its principles. An attempt in this direction was made in the Patents Act of 1919, which explicitly reaffirms the doctrine of the old Law as to "working"; but as no concurrent relief was provided for the patentee on proof of commercial working, the value of the British patent continued on its downward path.

One step only remains to be taken to deprive our patent law of its last vestige of biological significance, namely, the abolition of protection to the importer of a new industry. This change, however, is foreshadowed in the Report of the British Empire Conference of 1922, the delegates to which suggest that this principle should be sacrificed on the altar of imperial uniformity.

Is this country so far ahead of others in its industrial lead that it can afford to discard from its armoury the competitive principle which formed the basis of its early practice, securing for it that lead which it is frittering away to-day? The period of industrial progress, which dates from 1770, was marked by a continuous and fairly parallel growth in population and patent statistics which culminated in the year 1910. In 1911–12–13 the patent statistics began to fall away, and in the same year, 1911, the rate of growth of population showed a flattening tendency which has persisted to this day. These unfavourable symptoms are not equally reflected in the corresponding statistics of other countries.

Hence a case appears to be established for an inquiry into the working of a system which, as the result of successive modifications during the last fifty years, has lost all claim to industrial value, consistency, or administrative economy. In this inquiry all considerations of international or imperial comity should be subordinated to the national interest. The services of the inventor should be competed for by offering him the widest security for his monopoly compatible with the state of the national industry. On proof of commercial working, the validity of his patent should be freed from attack by proof of prior publication within the realm, and the patent freed from the payment of further renewal fees. On these lines the law and practice could be made consistent, effective, and economical. The cost of administration would be materially reduced, delays would be avoided, and a broad claim to the invention made secure so soon as the full consideration of the patent was given by its reduction to practice. There would, no doubt, be some increase in litigation, but patent litigation is a sign of healthy progress. These are matters clearly within the control of human agency, but courage and conviction are needed to bring about the reforms. When a vacancy occurs in a university readership the stipend is fixed at a figure calculated, as Lord Bacon says, "to whistle for the ablest men out of all foreign parts." Educationists do not accept the latest thesis as a substitute for personal service. In the same way, new teachers in industry should be requisitioned to keep our manufactures abreast of foreign enterprise. A nation which aspires to maintain its place in the hierarchy of power must conform to the teaching of natural laws.

E. W. HULME.

Gorseland, North Road,  
Aberystwyth.



### Transcription of Russian Names.

I do not wish to prolong the correspondence upon this subject further than to say that in their letter appearing in NATURE, October 14, p. 512, Messrs. Druce and Glazunov meet (in my opinion) none of the objections to a Czech-script transliteration of Russian pointed out in my letter (NATURE, July 15, p. 78), but merely reiterate their views,—in which, by the way, I think I could pick a number of holes were space available.

But I should prefer not being misquoted.

I did not "ask how many English people can correctly pronounce Czech letters like *č*": (for, of course, any one can pronounce that letter, *i.e.* English *ch*). I said I wondered "how many Britons would pronounce this 'c' [that is, *č*] correctly"—if they came across it suddenly in a Czech-script transliteration of Russian. The same criticism applies to the quoted Russian *ч* (=Czech *ch*), which would, therefore, be wrongly pronounced by the ordinary Briton as *ch* in church instead of as *ch* in loch.

As I previously pointed out, the very simple Royal Geographical Society II. system already exists in English; so why not use it? EDWARD GLEICHEN.

Royal Geographical Society, Kensington Gore,  
London, S.W.7, October 20.

APART from the typographical objections to a Czech transcription of Russian, which have been pointed out by Lord Edward Gleichen, there are other difficulties in its use. From Prof. Brauner's examples his does not appear to be a uniform letter-for-letter system, at all events in the treatment of Russian "soft" vowels. For example, the letter *я*, when initial, is transcribed *ja*, as in *языкъ, jazyk*; but if it happens to follow *д*, *н* or *т*, the letter *я* is dropped in the transcription and the Czech letters *д*, *н*, *т* are employed, *vide* Prof. Brauner's examples *Tatana, Dada*. And how is Russian "soft" *п*, which is represented in the Czech language by *ř*, pronounced *rřh* (*r* + French *j*), to be transcribed? For example, is *радъ* to be rendered *řad*, which gives the wrong pronunciation, or *rjad*, which is not Czech?

Again, it is not clear how Russian *е* and *ѣ* are to be treated. The natural Czech transcription would be *e* and *ě* respectively; but Prof. Brauner writes *Menděljev*, in which there are three different ways of transcribing Russian *e*.

The semivowel *и* is apparently to be transcribed *j*; but *ij*, *yj*, are not the Czech equivalents of *и*, *иѣ*. Does Prof. Brauner write *Čajkovskij*? (Incidentally, the average Briton would pronounce *čaj* like *cadge*.)

Prof. Brauner would, I hope, go so far as to abandon Czech for the transcription of Russian *ѣ*, and would let us write *Vinogradov*, though the true Czech would be *Vinohradov*.

Messrs. Druce and Glazunov maintain (NATURE, October 14, p. 512) that the system has the advantage of being complete; but what is the complete system? The foregoing points want clearing up.

JOHN H. REYNOLDS.

Royal Geographical Society, Kensington Gore,  
London, S.W.7, October 21.

### Volcanic Shower in the N. Atlantic.

THROUGH the courtesy of Dr. Russell (Director) and of Mr. J. W. Carruthers, of the Fisheries Laboratory of the Ministry of Agriculture and Fisheries at Lowestoft, I am enabled to record a shower of volcanic dust that occurred near the Faroes on Thursday, October 5, soon after 5 A.M.

The captain of the steam trawler *Prince Palatine* reports that his mate directed his attention to what

looked like a sudden appearance of land on the port quarter, when the vessel was about 62° 7' N. and 7° 43' W., Myggenæs (an islet west of Vagø) being on the starboard quarter. A heavy sandstorm soon enveloped the vessel, lasting for the extraordinary period of sixty-seven hours, during which the air resembled that of a London fog, while the vessel was covered with a deposit from stem to stern. Only a very small sample of the material is available; but Mr. Carruthers rightly concluded that it consisted of volcanic glass. With him, I note a few opaque particles; but these are in part white by reflected light, while others are merely fragments of deeply coloured glass. The material is a characteristic dust of volcanic glass, distinctly brown, and probably andesitic or basaltic. I can trace no crystals; some of the particles show twisted wisp-like forms, and the majority are comminuted pumice, resulting from attrition in the air of masses in which the volume of vesicles exceeded that of glass. Branching forms, like spicules of lithistid sponges, are thus common. Mr. Carruthers informs me that the Meteorological Office record shows that the position of the fall lay in a cyclonic depression, with a wind from somewhat east of south, blowing at 17 miles an hour.

The duration of the fall may possibly be due to a circling round of some of the material. Its occurrence seems worth recording, for comparison with dust that may have fallen on other ships at the same date. Some account may be forthcoming from the northern isles of the Faroe group. It is most probable that the source was an eruption in Iceland, the dust having in that case travelled about 500 miles. The fine glassy dust has no doubt become sifted out from coarser matter during transit.

GRENVILLE A. J. COLE.

Carrickmines, Co. Dublin, October 21.

### Orientation of Molecules in a Magnetic Field.

ABOUT this time last year, at the suggestion of Prof. A. W. Stewart, I began some work to test whether or not the molecules of a substance (more particularly at first of a liquid) underwent an orientation when placed in a magnetic field. So far the results all seem to indicate that something of the kind does take place. The method first adopted was analogous to Laue's method of diffracting X-rays. A parallel pencil of X-rays was directed through a small cell containing barium iodide placed between the poles of a large electro-magnet, and was then received on a photographic plate. During the first complete exposure no current was run through, during the next current was run through, and the process was repeated with a second pair of plates. In the case of both pairs of plates it was found that the disc which came up dark on development was greater in diameter for the exposure during which the magnet had been excited than for that when it had not been excited. The increase was more than ten per cent. of the original diameter. This effect may be analogous to that observed when a pencil of X-rays is passed through a powdered crystal. So far this method has not been used in a very refined manner, but it is hoped to continue with it and to improve it. The results obtained by it, however, have been corroborated by entirely independent methods, in which the properties of X-rays were not made use of.

The question of the nature of the orientation, in addition to that of its occurrence, is still under investigation here, and I hope to be able shortly to make a further communication on this subject, giving more detail as to both the results obtained and the methods employed.

MARSHALL HOLMES.

The Sir Donald Currie Laboratories,  
Queen's University, Belfast, October 10.

### The Ramsay Memorial in Westminster Abbey.

IT is a somewhat inhuman trait among British men of science, and in particular among chemists, that they have not sufficiently secured public honour for their fathers who spiritually begat them. Boyle's resting-place is unknown, and there is no express memorial to him in the Royal Society, of which he was the greatest founder; and to the chief of his chemical successors, however well remembered in the records of their science, tangible monuments for the most part exist only where purely local pride has preserved or erected them. The ceremony of November 3, therefore, when a medallion tablet in memory of Sir William Ramsay was unveiled in Westminster Abbey, was a most welcome manifestation of a world-wide tribute.

The British nation at large was represented in the person of H.R.H. the Duke of York (the Prince of Wales being prevented by a riding mishap); Sir Charles Sherrington, president of the Royal Society, stood for British science, together with a large gathering which included many of its foremost followers; Prof. Le Chatelier came from Paris as president of the Academy of Sciences; while the presence of the ambassadors and ministers of no fewer than twenty-one countries attested the far-reaching fame of Ramsay's achievements. Lady Ramsay was present, with Mr. W. G. Ramsay and Dr. and Mrs. H. L. Tidy and their children. A short choral service was held in the nave, during which the Duke

of York unveiled the tablet and offered it to the Dean, who in dedicating it referred to the panels commemorative of Joule, Kelvin, Hooker, Darwin, and Lister, among which it is to be permanently set. The medallion was provided from the Ramsay Memorial Fund.

This fund, begun in 1917, consists of nearly 58,000*l.* raised by private subscription all over the world; and the capitalised value of the additional endowments by Dominion and foreign governments is as much again. Eleven Ramsay Fellowships, each of annual value at least 300*l.*, enable promising research-students to come to carry on work in any selected chemical laboratory in Britain, from Canada, France, Switzerland, Greece, Italy, Norway, Sweden, Denmark, Spain, Holland, and Japan; and there are also British Ramsay Fellowships, including one specially connected with Glasgow, Ramsay's *alma mater*. From the remainder of the fund, 25,000*l.* is being devoted to a laboratory

of chemical engineering at University College, London, where Ramsay taught and worked for 26 years; there, also, an annual Ramsay medal has been founded.

The Abbey bronze, which was executed by Mr. C. L. Hartwell, A.R.A., is illustrated in the accompanying photograph (Fig. 1). The artist has been compelled, owing to the nature of the only position available in the Abbey, to give to the eyes a downcast expression which in life they rarely assumed. Probably no medium could convey the inward and outward sparkle which lit Ramsay's eyes under their characteristically lifted brows; and his open glance and the quick charm of his smile defy portrayal.

As a chemist, Ramsay had three great gifts in nearly equal degree: boldness of imagination, amazing audacity in conceiving experiments, and extraordinary constructive and manipulative deftness in carrying them out. Of his earlier researches the importance is exemplified by his discovery of the nature of Brownian movement, by the work embodied in the Ramsay-Young equation, and by that which gave the Ramsay-Eötvös method for measuring molecular association in liquids. In 1894, he alone of chemists had the courage to see in Rayleigh's abnormal nitrogen-densities the indication of a new atmospheric element and to seek it and find it; his discovery of helium came as a dramatic reward for a search after further sources of



FIG. 1.—The Ramsay Memorial, Westminster Abbey.

argon; and with the advent of liquid air he, with Travers, drove on with irresistible impetus to the detection and isolation of neon, krypton, and xenon. Only Berzelius has discovered as many new elements; no one but Ramsay has laid bare a complete and unforeseen group. In radioactivity he found fresh scope; and the experimental proof that helium is generated during radioactive change founded the era of the transmutation of elements. Possibly the finest example of his skill was given when, with Whytlaw-Gray, he measured the density of one-thousandth of a milligram of gaseous radium-emanation—the last member of his own group of inert gases.

Like Priestley and Davy, Ramsay opened up a new world for science; and physics, chemistry, and even astronomy are enriched, not alone by the discoveries which he made, but also by the methods which he devised and so freely handed on to others. I. M.

S. P. Langley's Pioneer Work in Aviation.<sup>1</sup>

By Prof. L. BAIRSTOW, C.B.E., F.R.S.

THE work of Prof. S. P. Langley in aviation is such a first-rate example of systematic inquiry—a type rightly called scientific—that no excuse is needed in again directing attention to it. Progress was made step-by-step in the face of formidable difficulties, and no attempts were made to solve the problems of mechanical flight by bursts of brilliance or invention. The scientific method appears to be most suitable for the great bulk of human endeavour and is required in the interpretation and development of striking innovations.

Langley was a creative investigator and not merely a producer of data. It is probably not wide of the mark to say that his experimental results are now rarely appealed to, yet who can doubt that the whole course of aviation was largely determined by his efforts? Langley's work may be divided into two periods—1887 to 1896, and 1896 to 1903. The end of this period is almost coincident with the earliest successes of the Wright Brothers. The later Hammondsport trials on a modified Langley aeroplane have obscured the real issue, and it is better to leave these out of account as having nothing to do with Langley and his methods.

The story can be readily told in extracts from the originals; in 1901 Langley said:

"And now, it may be asked, what has been done? This has been done: a 'flying machine,' so long a type for ridicule, has really flown; it has demonstrated its practicability in the only satisfactory way—by actually flying—and by doing this again and again under conditions which leave no doubt.

"There is no room here to enter on the consideration of the construction of larger machines, or to offer the reasons for believing that they may be built to remain for days in the air, or to travel at speeds higher than any with which we are familiar. Neither is there room to enter on a consideration of their commercial value, or those applications which will probably first come in the arts of war rather than those of peace; but we may at least see that these may be such as to change the whole conditions of warfare, when each of two opposing hosts will have its every movement known to the other, when no lines of fortification will keep out the foe, and when the difficulties of defending a country against an attacking enemy in the air will be such that we may hope that this will hasten rather than retard the coming of the day when war shall cease."

This note was written before the advent of the man-carrying aeroplane—two years before. Some of the prediction is yet unfulfilled, particularly that as to remaining for days in the air, but it accurately anticipated war uses before civil. In continuing his story Langley shows that he had no commercial interests in his efforts:

"I have thus far had only a purely scientific interest in the results of these labours. Perhaps if it could have been foreseen at the outset how much labor there was to be, how much of life would be given to it and how much care, I might have hesitated to enter upon it at all. And now reward must be looked for, if reward there be, in the knowledge that I have done the best in a difficult task, with results

which it may be hoped will be useful to others. I have brought to a close the portion of the work which seemed to be specially mine—the demonstration of the practicability of mechanical flight—and for the next stage, which is the commercial and practical development of the idea, it is probable that the world may look to others. The world, indeed, will be supine if it do not realise that a new possibility has come to it, and that the great universal highway overhead is now soon to be opened."

This passage is of extreme interest; it emphasises the scientific spirit and the relation of science to industry. Monetary reward did not come to Langley, nor did the merits of his work save him from biting criticism in the press on the failure of his man-carrying aeroplane. Time has probably enabled us to take a more detached and fairer view. These early remarks by Langley prepare us for a note by his assistant, Mr. Manly:

"In the spring of 1904 after the repairs to the main frame were well under way, the writer [Mr. Manly] on his own initiative undertook to see what could be done towards securing for Mr. Langley's disposal the small financial assistance necessary to continue the work; but he found that while a number of men of means were willing to assist in the development of the aerodrome [aeroplane] provided arrangements were made for later commercialisation, yet none were ready to render assistance from a desire to assist in the prosecution of scientific work." On the other hand, Langley "had given his time and his best labours to the world without remuneration, and he could not bring himself at his stage of life to consent to capitalise his scientific work."

The problem of financing and directing scientific research is seen here as a striking example of the failure of our systems. The troubles still exist in large measure, and much has yet to be learnt before science and industry combine for efficiency and economy. The relation caused comment by Manly to the effect that:

"Persons who care only for the accomplished fact may be inclined to underrate the interest and value of this record [1911]. But even they may be reminded that but for such patient and unremitting devotion as is here enregistered, the new accomplished fact of mechanical flight would still remain the wild unrealised dream which it was for so many centuries."

Throughout his writings, Langley made a clear distinction between two subjects which he called "aerodynamics" and "aerodromics"—a distinction which still exists but is differently described. His division corresponds very closely with the modern expressions "performance" and "control and stability," both being now regarded as branches of aerodynamics. The scientific advisers of the Air Ministry are more and more turning to the study of "aerodromics," on which progress towards safety in flying is seen largely to depend. Its problems are still very difficult. In concluding this note probably the best summary is Langley's own:

"I am not prepared to say that the relations of power, area, weight, and speed, here experimentally established for planes of small area, will hold for indefinitely large ones; but from all the circumstances

<sup>1</sup> Extracted from an address delivered as chairman of the Royal Aeronautical Society on October 5.

of experiment, I can entertain no doubt that they do so hold far enough to afford assurance that we can transport (with fuel for a considerable journey and at speeds high enough to make us independent of ordinary winds) weights many times greater than that of a man." And

"I desire to add as a final caution, that I have not asserted that planes such as are here employed in experiment, or even that planes of any kind are the best forms to use in mechanical flight, and that I have also not asserted, without qualification, that mechanical flight is practically possible, since this involves questions as to the method of constructing the mechanism, of securing its safe ascent and descent, and also of securing the indispensable condition for the economic use of the power I have shown to be at our disposal—the condition, I mean, of our ability to guide it in the desired horizontal direction during

transport,—questions which, in my opinion, are only to be answered by further experiment, and which belong to the inchoate art or science of aerodynamics, on which I do not enter."

The problems of Langley are still problems, and we have very much to learn about the control of aeroplanes. An interesting commentary on Langley's work is provided by the fact that on October 19 the world's record for gliding flight was obtained on a replica of the Langley machine and not by a glider following the modern conventional aeroplane. It would be wrong, I think, to argue superiority of type for the successful glider, but it is a not unwelcome reminder of the enormous progress made by a scientific pioneer in a time when science in aviation is at a very low ebb.

## The Early History of the Land Flora.<sup>1</sup>

By Dr. D. H. SCOTT, F.R.S.

### II.

WHEN we reach the Upper Devonian flora we find ourselves in the midst of a comparatively familiar vegetation. A few of the early forms may have survived, but the bulk of the plants were highly organised Vascular Cryptogams or Spermophytes. While in the Early Devonian no true Ferns have been found, a branched, naked rachis being the nearest approach to a frond, the later vegetation has been called the Archaeopteris flora, after the magnificent ferns or fern-like plants of that genus, of which the famous *A. hibernica* is the type. We do not, however, know for certain whether these fine plants were really Ferns, or fern-like seed-plants. The presence of true Ferns is more surely attested by Dawson's *Asteropteris*, from the State of New York, which has the structure of a Zygopterid, a group well known from Carboniferous rocks. Lycopods had attained a very high development, as shown especially by the genus *Bothrodendron*, of which the large heterosporous cones are known.

The now extinct group of the Sphenophyllums, characteristic of Carboniferous times, had also made its appearance in the Upper Devonian flora; the whorled leaves of these early forms were deeply cut, not wedge-shaped as in most of the later representatives. Nathorst's genus *Hymenia*, which already appears in the Middle Devonian, may probably have been a precursor of the Sphenophylls.

Another family, represented by *Pseudobornia*, of Nathorst, from Bear Island, is only known from the Upper Devonian. It was a large plant, with whorled leaves, palmately divided, and further cut into narrow segments, while the long cones are believed to have produced spores of two kinds. *Pseudobornia* is at present quite isolated; its affinities may be either with the Sphenophylls or the Horsetails. Apart from this case, the Equisetales do not appear to be represented among our present Devonian records, for the evidence for the occurrence of Archaeocalamites at that period seems to be inadequate. The group, however, was so well developed in Lower Carboniferous times that there can be no doubt it had appeared long before.

<sup>1</sup> Continued from p. 607.

The best proof of the presence of seed-plants in the Upper Devonian is to be found in the occurrence of petrified stems, which, from their organisation, must presumably have belonged to advanced Gymnosperms. The genus *Callixylon*, apparently allied to the Lower Carboniferous *Pitys*, has a peculiar and beautiful structure in the secondary wood, the pits being localised in definite groups. The wood appears more highly differentiated than that of most living Conifers.

Thus the main lines of subsequent evolution were already well laid down in Upper Devonian times. We know practically nothing of their origin. Some botanists believe that the higher plants may have had a common source in some group, already vascular, such as the Psilophytales, while others hold that the main phyla have always been distinct, from the Algal stage onwards. The existence of these rival monophyletic and polyphyletic hypotheses, both maintained by able protagonists, shows how little definite knowledge of the evolutionary history we possess.

The Lower Carboniferous flora bears a close general resemblance to the Upper Devonian, but is much better known. The wealth of forms is, indeed, so great, that only the merest outline of the main features can be given here.

The Lycopods were abundantly developed. Many species of *Lepidodendron* and *Lepidophloios* are known, not only by external characters, but often by anatomical structure. While the primary ground plan of their anatomy was not unlike that of some of the simpler Lycopods of our own day, most of the old forms developed a considerable zone of secondary wood, and a massive periderm. They were, in fact, adapted to play the part of forest trees. The genus *Sigillaria*, however, so important in the Upper Carboniferous flora, was still scantily represented.

As regards their fructification, the Lower Carboniferous Lycopods had attained the highest level which the class ever reached. Not only were their cones constantly (so far as observed) heterosporous, with an extreme differentiation of the two kinds of spore, but some of them even developed a kind of seed, a structure quite unknown among Club-mosses of later than Carboniferous age. In the seed-like fructification

(Lepidocarpon) a single megaspore only came to maturity, constituting the embryo-sac, while an integument, like a seed-coat, grew up round the sporangium.

The prothallus is sometimes well preserved, both in the seed-like bodies and in the more ordinary megaspores. In the latter (*Lepidostrobos Veltheimianus*), Dr. Gordon has recorded a perfectly typical archegonium, showing that the details of reproduction in these old Lycopods were the same as in their modern heterosporous representatives.

The best-known member of the Horsetail race was *Archæocalamites*, remarkable for the long leaves, often repeatedly forked, very different from the foliage which we are accustomed to associate with the Equisetales. The later *Calamites* were more or less intermediate in this respect. Anatomically, the *Calamites*, whether of Lower or Upper Carboniferous age, developed much secondary wood, and, like many contemporary Lycopods, became trees. The Lower Carboniferous *Protocalamites* is remarkable for possessing primary wood, centripetally formed, thus presenting some analogy with the Sphenophylls, in which this tissue is highly developed.

The cones attributed to *Archæocalamites* are, curiously enough, intermediate in structure between modern *Equisetum* cones and those of the Upper Carboniferous *Calamites*, for sterile bracts were either absent, or developed only at long intervals. In *Equisetum*, of course, they are absent altogether, while in the well-known *Calamostachys* and allied Upper Carboniferous fructifications, the sterile whorls are equal in number to the alternating fertile verticils. It must be admitted, however, that our knowledge of Lower Carboniferous fructifications of this group is still somewhat scanty.

The Sphenophylls of the period were already very advanced, and in the genus *Cheirostrobos* appear to have reached their zenith. The great cones of this striking plant, with their elaborate and perfect apparatus of compound sporangium-bearing organs, and protective sterile appendages, are certainly the most complex cryptogamic fructifications known, from any period. Thus, in certain directions, the Lower Carboniferous plants had attained a height of development which has never since been equalled.

Sphenophyllum itself still had, for the most part, the deeply cut leaves of the Upper Devonian species. Where the anatomy is known (*S. insigne*, from Burnt-island), it is of the same general type as in the later Upper Carboniferous forms, but apparently somewhat less specialised. It is worth remarking, that all the Sphenophylls formed secondary wood, though they were small plants. Thus growth in thickness by cambium was not confined to arborescent forms in Palæozoic times, any more than it is now.

As regards the affinities of the Sphenophylls, some relation to the Horsetail stock seems evident, as indicated by the whorled leaves, the general organisation of the cones, and the detailed structure of the sporangia. Presumably these two lines sprang from a common source, but what it was is still unknown. Further affinities, once suggested, with the Lycopods and the recent *Psilotaceæ* have not been confirmed and are probably illusory. Neither has Lignier's hypothesis of a common origin of both branches of the *Articulatæ*

from Ferns, gained any support from the fossil record. The *Articulatæ*, as a whole, remain a completely isolated phylum.

The Ferns of the Lower Carboniferous were well developed and varied. We meet with the usual difficulty in distinguishing between the fronds of true Ferns, and those of the so-called "Seed-Ferns," which simulated them in habit. Where, however, anatomical characters are available, we find no approximation whatever between the two groups. Pteridosperms and Ferns at all times show themselves perfectly distinct, whenever our knowledge admits of an adequate comparison.

We have fairly abundant structural material of Lower Carboniferous Ferns, but it seems that practically all of it represents the group called *Primo-filices* by Arber, who by this name meant to suggest age, not primitiveness. They were curious plants, and many of them must have been very unlike any Ferns now living. Unfortunately, our knowledge of their habit is by no means equal to that of anatomical detail.

The chief family in the Lower Carboniferous is that of the *Zygopterids*, of which several genera are represented. As we have seen, this family had already appeared in Upper Devonian times. The vascular cylinder of the stem shows some differentiation of the wood into a central region (either a mixed pith or a core of small, short tracheids), and a wide outer zone of larger elements. The petiole always has a peculiar structure, with a bilateral strand (often of complex form) giving off branch-bundles to the right and left. It is remarkable that the genus *Clepsydropsis*, once thought primitive on account of its simple petiolar structure, has been shown to possess an exceptionally high organisation of the stem.

The most striking point is the morphology of the frond. Even where there were only two series of pinnae (as in normal compound leaves) their plane was not parallel to that of the main rachis, but at right angles to it. Moreover, in several genera there was the greater peculiarity that the pinnae were in four rows, two rows on each side, a condition unexampled in ordinary leaves. In *Stauropteris* this quadriseriate branching was repeated in successive ramifications, so that the form of the whole frond was compared by Lignier to a bush. In this genus it is practically certain that the leaflets had no blade, and throughout the family there is rarely any proof of its presence.

The other Lower Carboniferous family of *Primo-filices*, the *Botryopteridæ*, is at present represented for that period by a single species, the *Botryopteris antiqua* of Kidston, a plant in all respects of simpler organisation than the *Zygopterids*, and apparently more like an ordinary Fern.

Sporangia are known in several cases. Those of *Stauropteris* were borne singly on ultimate branches of the frond; they had no annulus, and are very similar to the sporangia associated with the Early Devonian *Asteroxylon*. In the fructification attributed to *Diplolabis* the sporangia are grouped in a sort of synangium, while those associated with *Botryopteris* have a biseriate annulus.

Both families show some affinity with the older members of the *Osmundacæ*, while a relation to the *Adder's Tongues* has also been traced. But in both directions the connexion seems to be somewhat remote.

We are dealing, in the Lower Carboniferous Primofilices, with early races, already specialised on their own lines, and probably only indirectly connected with the main current of Fern-evolution.

The "Seed-Ferns" or Pteridosperms appear to have attained a great development in Lower Carboniferous times. A considerable variety of seeds is met with, and in some cases there is strong evidence for attributing them to plants with a fern-like foliage. In one such example, described by Nathorst, the seed (*Thysanotesta*) is remarkable for having a distinct pappus; it was thus adapted to wind-dispersal, like the achenes of Composites.

No less than six families, referred to Pteridosperms, are known by their anatomy. In only one is there any evidence as to the seed, but all these groups show, in their structure, a nearer relation to known "Seed-Ferns" than to any other phylum. The case referred to is that of *Heterangium*, a genus with a solid wood and no pith. A beautifully organised seed (*Sphærostoma*, Benson), obviously related to that of the Upper Carboniferous *Lyginopteris*, is found in close association with *Heterangium Grievei* and probably belonged to it. The two genera, *Heterangium* and *Lyginopteris*, are closely related, as shown by Dr. Kubart's discovery of intermediate anatomical features, in species of Millstone Grit age.

The *Lyginopterideæ* extend to the Upper Carboniferous, but the other five anatomical groups are peculiar to the Lower.<sup>1</sup> They show a great variety in structure, but none of them bear any anatomical resemblance to contemporary Ferns. Our knowledge of so many, more or less isolated, types indicates that we have only found a few relics of what was really a most extensive class of plants.

The family most richly represented is that of which *Calamopitys* is the type. A number of species of *Calamopitys* are known; they are plants with a pith (sometimes "mixed"), large leaf-trace bundles, and much secondary wood. The petioles, often of large size and with many vascular strands, have long been

<sup>1</sup> Space does not admit of any account of their remarkable characters. The five type-genera are: *Rhætiangium*, *Stenomylon*, *Protopytis*, *Cladoxylon* and *Calamopitys*.

known as *Kalymma*. Some of the species, with dense secondary wood of a Coniferous type, have been separated by Dr. Zalesky under the name *Eristophyton*. An interesting new genus, *Biligneæ*, in which the pith is replaced by a central column of short tracheids, has been discovered by Dr. Kidston.

Apart from the "Seed-Ferns," we have the remarkable Lower Carboniferous family of the *Pityææ*, already represented, as we have seen, in the Upper Devonian. *Pityæ* was a genus of trees, with a relatively large pith traversed by slender strands of wood, while the secondary wood was of an *Araucarian* type. The foliage was quite unknown until recently, when Dr. Gordon discovered the leaves attached to the twigs in a species from the shores of the Firth of Forth. The leaves are totally different both from those of any Pteridosperm and from the well-known foliage of the Upper Carboniferous *Cordaiteæ*; they rather resemble the needles of a Fir, though more complex in structure. Dr. Gordon suspects an affinity with *Araucarian* Conifers.

Perhaps the chief conclusion that follows from this hasty sketch of the earlier floras is the great distinctness of the main phyla.

The *Lycopods* may perhaps become merged, as we trace them back, in the early Devonian *Psilophytales*, but nowhere approach any other group.

The *Articulatæ* appear as an isolated phylum throughout.

The Ferns may have come from thalloid plants, through some of the forms of Early Devonian age, where the frond is only represented by a bladeless rachis. The "Seed Ferns" now appear as a totally distinct line, parallel in certain respects to the true Ferns, but nowhere joining them, unless it be in some common thalloid source, about the *Psilophytales* level.

The higher *Gymnosperms*, represented in the period considered by *Pityæ* and its allies, may have passed through an earlier Pteridosperm stage, but this is not proven. The *Spermophyta* generally may, for all we know, be as ancient as any other vascular plants.

Thus phylogeny still eludes us, though it remains the ultimate goal of the palæontologist.

## Obituary.

DR. C. G. KNOTT, F.R.S.

THE sudden death of Dr. C. G. Knott, reader in applied mathematics in the University of Edinburgh, and general secretary of the Royal Society of Edinburgh, has deprived physical science of a devoted follower and an accomplished exponent. On Wednesday, October 25, he was lecturing as usual and attending, in the afternoon, to the business of the Royal Society. At night he was taken ill and died of heart failure in a few hours.

Born at Penicuik in 1856, Knott entered the University of Edinburgh in 1872 and soon joined a little band of enthusiastic workers in the laboratory of Prof. Tait. To study under that great teacher was a privilege and an inspiration. The laboratory, then a new feature in university physics, was a small attic, meagrely equipped. Only a few of the best pupils

cared to seek admission; they plunged at once into research, either sharing in the investigations on which Tait happened to be engaged, or undertaking some independent inquiry of their own. Tait was then collecting data for his thermoelectric diagram, and Knott's training was to measure the electromotive forces between pairs of some twenty different metals, through a wide range of junction temperatures. He also began the series of magnetic researches he was afterwards to pursue with the help of his own Japanese pupils. In 1879 he was appointed Tait's assistant, but gave up that post in 1883 when he became professor of physics in the University of Tokyo. After eight years as professor in Japan he returned, in 1891, to his own University of Edinburgh, where he spent the rest of his life, at first as lecturer and later as reader in applied mathematics. He also acted as the official adviser of students reading for honours in mathematics

and physics, or for degrees in science—a task which his wide knowledge, his unflinching good nature, his geniality, his ready sympathy, and his infinite capacity for taking pains, fitted him to discharge to the great advantage of many generations of undergraduates. For the last ten years he also held the office of general secretary in the Royal Society of Edinburgh, where the same characteristics found further exercise, along with others which eminently qualified him for editorial work.

In Japan, with pupils such as Nagaoka, Knott's influence as a teacher soon became conspicuous, and has proved enduring. His love of research was infectious. The school of young Japanese seismologists and magneticians, then in its infancy, owed much to his example and encouragement. Along with Tanakadate, he carried out a magnetic survey of "all Japan." His industry was untiring and the habit of research, formed in his student days, never left him. All his scientific work is sound and thorough. His published papers, more than seventy in number, cover a wide range, but the subjects of ferro-magnetism, especially in its relation to strains, and of seismology, continued to engage his main attention. His book on the physics of earthquake phenomena, published in 1908, is an admirable digest of the whole subject, linking up the older with the newer seismology. His last long paper, published by the Royal Society of Edinburgh in 1919, completed a series in which the theory of earthquake-wave propagation is discussed with much originality.

Probably the best known of Knott's books is his *Biography of Tait* (Camb. Univ. Press, 1911). No other disciple was so fit to undertake the difficult task of writing the life of the master, for on Knott the mantle had most directly fallen, and he, more than any, continued to wear it. Tait himself, in a preface to his collected papers, speaks of Knott as an adept

in quaternions as well as in physics, and adepts in quaternions have always been rare. Knott's grasp of mathematical methods, his intimacy with Tait's work and appreciation of Tait's genius, and above all his affectionate comprehension of an often whimsical personality, inspired him to write what is beyond question an exceptionally adequate and deeply interesting biography. More recently he organised the Napier tercentenary (1914), and edited the memorial volume. Almost his last act was to pass for the press the final sheets of collected papers by the late Dr. John Aitken, F.R.S.

An unselfish, modest, Christian gentleman, whose life was a constant round of unobtrusive service, Knott is mourned by many friends. J. A. E.

By the death of Thomas Francis Moore the National Museum, Melbourne, has lost one of the most valued members of its staff. Mr. Moore had filled the position of osteologist at that institution for nearly twenty-two years. His work was of a very high order and universally known. As a link with the past, it may be mentioned that Mr. Moore's father, Mr. T. J. Moore, was for forty years curator of the Liverpool Museum, and from 1865 to 1884 organised and took part in the Liverpool Free Public lectures. Dr. Frederick Moore, of the East India Company's Museum, well known by his work on oriental Lepidoptera, was an uncle of Mr. T. F. Moore.

THE *Chemiker Zeitung* of October 17 reports the death, at the age of sixty-four years, of Prof. Lassar-Cohn, who had occupied the chair of chemistry at Königsberg since 1894. His work was mainly in the fields of organic and technical chemistry, and his textbooks were well known in English translations.

### Current Topics and Events.

THE following is a list of those recommended by the president and council of the Royal Society for election to the council at the anniversary meeting on November 30:—*President*: Sir Charles Sherrington; *Treasurer*: Sir David Prain; *Secretaries*: Mr. W. B. Hardy and Dr. J. H. Jeans; *Foreign Secretary*: Sir Arthur Schuster; *Other members of Council*: Prof. V. H. Blackman, Prof. H. C. H. Carpenter, Prof. T. R. Elliott, Prof. A. Harden, Sir Sidney Harmer, Prof. W. M. Hicks, Prof. H. F. Newall, Prof. G. H. F. Nuttall, Prof. D. Noel Paton, Lord Rayleigh, Prof. O. W. Richardson, Sir Ernest Rutherford, Dr. Alexander Scott, Mr. F. E. Smith, Sir Aubrey Strahan, and Prof. J. T. Wilson.

It is announced in *Science* that Dr. S. W. Stratton, director of the Bureau of Standards at Washington for the past twenty-one years, has been elected president of the Massachusetts Institute of Technology. Dr. Stratton was professor of physics and electrical engineering at the University of Illinois and professor of physics at the University of Chicago before his appointment as director of the Bureau of Standards

in 1901; he found the department a small office employing three or four people, and from it he built up the present department with a staff of about 900. Commenting on Dr. Stratton's resignation, Mr. Hoover is reported by the *New York Times* to have said: "The Massachusetts Institute of Technology, an educational institution, finds no difficulty in paying a man of Dr. Stratton's calibre three times the salary the government is able to pay him." It appears that it is impossible to live and to provide for old age while at Washington on a government salary, and for this reason it is difficult to induce men of science to undertake responsible national posts.

PROF. A. SMITHELLS' retirement at the end of the present session from the chair of chemistry of the University of Leeds, after thirty-eight years of active work, will be a serious loss to the whole educational world as well as to the narrower sphere of academic life of the University in the progress and development of which he has played so conspicuous and devoted a part. His intention in retiring is to employ part

of his leisure in literary and scientific work with which his present multifarious duties, not only as head of a very large and busy department, but also as member of numerous university committees and outside public bodies, seriously interfere.

THE use of the cinema as a means of agricultural education among farmers is in contemplation in this country, and at least one organisation is understood to be preparing a set of films. A recent announcement in *Le Matin* indicates that France may, however, be first in the field. It is stated that the Ministry of Agriculture has submitted to the President of the Republic an order authorising an annual grant of 500,000 francs for the purpose of installing, in agricultural colleges and schools and in the rural communes, cinematographic appliances which would be used for the popularisation of scientific agriculture. There is no question that the cinematograph could serve a highly useful purpose; it is not only more attractive than the lantern slide, but it brings out points that could not otherwise be readily shown. It may be doubted whether the ordinary lantern slide could be dispensed with, however, and the lecturer of the future will probably try to use both films and slides.

AT the International Congress of Eugenics held in New York in 1921 an International Commission of Eugenics was re-formed from a previously existing committee. This committee held its first annual meeting at Brussels on October 7 and 9. By a unanimous vote it was decided to invite Germany to co-operate in its labours in the future, delegates from the United States, France, Denmark, Holland, Norway, together with Major Darwin, the chairman, and Dr. Govaerts of Belgium, the secretary, being present. The Société Belge d'Eugénique held a series of conferences at the same time, at which interesting papers were read. This society is to be congratulated on the assistance it is now receiving from the Solvay Institute, both as regards quarters and funds.

UPWARDS of eighty members and visitors attended the last conversazione of the Natural History Museum Staff Association for the current year, which was held in the Board Room on November 1. Among the many interesting exhibits placed round the room may be mentioned the following: A selection of birds collected in the course of the Shackleton-Rowett Expedition to the Antarctic regions by the *Quest*; life-size casts of the dolphins recently received by the Museum from Tung Ting Lake, China, about 800 miles from the sea; a series of specimens illustrating sporadic variation in plaice and flounder; life-size models in colour of toads and frogs shortly to be placed in the exhibition gallery; enlarged model of an extinct marine arthropod found in the Upper Silesian rocks of Oesel in the Baltic; examples of tropical spiders which have been discovered alive in this country; a selection of the butterflies collected in the course of the Mount Everest Expedition 1922, and a small fragment of the rock (biotite-schist) at

the highest point reached by the climbing party; diagrams of genera of British Carboniferous corals, and others illustrating the distribution of mammals in Africa; and specimens illustrating the introduction of the chrysanthemum into this country in the eighteenth century. In addition, Mr. O. H. Little showed beaded casts of crustacean or worm tracks from the Nubian sandstone at Wady Arabah, Egypt. Messrs. James Swift and Son exhibited recent models of their microscopes and accessories, and Messrs. Baird and Tatlock showed examples of glassware and other apparatus for museum and laboratory use.

THE Society of Chemical Industry, which was founded in 1881 for the promotion of applied chemistry and chemical engineering, has now a roll of some 5500 members scattered over all parts of the world. No less than eighteen local sections have been formed at home and abroad, each section having its own officers and programme, and leading to some extent an independent existence. There is also a chemical engineering group, which has its headquarters in London. The Edinburgh and East of Scotland section has included in its programme an address by Prof. G. Barger on some recent advances in bio-chemistry and another by Prof. H. S. Allen on modern theories of the structure of the atom, the latter being a joint meeting with the Glasgow section, the Royal Scottish Society of Arts, and the local section of the Institute of Chemistry. The programme of the Liverpool section is more industrial; papers have been arranged dealing with bleaching agents for textiles and paper pulp, chemical industry during the war in Great Britain and France, saponification of fatty oils, patent fuels, synthetic tannins, fractional distillation, and sulphur. These two programmes are wide and varied in their appeals, and serve to show the range of the society's activities.

THE report of the council of the North-East Coast Institution of Engineers and Shipbuilders for the year 1921-22, which has recently been issued, marks the close of the thirty-eighth session of the society. In addition to the presidential address by Sir William J. Noble, thirteen papers were presented at meetings during the session, and twelve are printed in the Transactions. They cover a wide field, there being three papers dealing with naval architecture, three with internal combustion engines, two with electrical and two with mechanical engineering, in addition to a paper on casualties at sea and another on standardisation. The roll of the society in July contained 1594 names, of which 486 were those of members, 542 of associate members, and 388 of graduates. The society benefited by two gifts of 500*l.* during the year; one was from Mr. A. E. Doxford, a past president, for the endowment fund, and the other from the Furness Shipbuilding Co., Ltd., to provide an income for the newly formed Middlesborough branch. The Graduate Section had a successful session, including, in addition to its formal meetings, a number of visits to works. Study circles inaugurated in 1920, specialising in the internal combustion engine and strength of ships, continued to meet. A



programme of the papers to be read and the works' inspections arranged for the Graduate Section during the current session has been issued and gives promise of an interesting and instructive series of meetings.

THE tenth annual meeting of the Indian Science Congress, under the auspices of the Asiatic Society of Bengal, will be held at Lucknow on January 8-13, 1923. The congress will be opened by Sir Spencer Harcourt Butler, Governor of the United Provinces, who has consented to be patron. The president of the congress is Sir M. Visvesvaraya, and the presidents of the sections are as follows: Agriculture—Dr. Kunjan Pillai, Trivandrum; Physics—Dr. S. K. Banerji, director of the Observatory, Colaba, Bombay; Chemistry—Dr. A. N. Meldrum, Royal Institute, Bombay; Botany—Mrs. Howard, Pusa; Zoology—Prof. G. Matthai, Government College, Lahore; Geology—Dr. Pascoe, Indian Museum, Calcutta; Medical Research—Lt.-Col. Sprawson, Lucknow; Anthropology—Dr. J. J. Modi, Bombay. In addition to the regular programme of the meetings of the scientific sections, a series of general scientific discussions has been organised, beginning with one on colloids by Dr. S. S. Bhatnagar, of Benares. A series of illustrated public lectures on subjects of popular scientific interest has also been arranged, details of which will be announced later. Further particulars regarding the congress may be obtained from Dr. C. V. Raman, general secretary, Indian Science Congress, 210 Bowbazaar Street, Calcutta. The local secretaries at Lucknow are Prof. P. S. MacMahon and Dr. Wali Muhammad of the Lucknow University.

THE British Non-ferrous Metals Research Association has just issued a statement as to the investigations already in hand and the work being undertaken by the Association. The record is one of active work, and is to be commended to other Research Associations as a model to be imitated. The practice has been to allot the investigations to existing laboratories of sufficient standing, the work being carried out under the direction of the chief of the laboratory in consultation with the Director of Research, Dr. R. S. Hutton. The subjects in which progress has already been made are: effect of small quantities of impurities on the properties of copper; conditions of obtaining sound ingots of brass; methods of jointing metals; abrasion and polishing of metals; atmospheric corrosion; properties of rolled nickel-silvers; influence of oxide on aluminium; and cause of red stains on finished brass. Information has also been collected respecting the electric melting of non-ferrous metals. In regard to the first of the subjects mentioned, the effect of oxygen on copper has been studied in detail and the effect of other elements is now being examined. The laboratories with which arrangements have been made include the National Physical Laboratory; the Universities of Birmingham, Sheffield, and Manchester; the Research Department, Woolwich; the Royal School of Mines, and the Research Department of Metropolitan Vickers, Ltd. The pamphlet also contains particulars of the means adopted for circulating information among members,

and concludes with an outline of the future work proposed for the Association.

A STATE Institute of Radiology has been established at Prague, under the direction of Dr. Felix.

IN consequence of the great demand for seats at the joint meeting of the Royal Geographical Society and Alpine Club for the Mount Everest film lecture on November 21 at the Central Hall, London, it has been found necessary to arrange two meetings—for the afternoon at 3 P.M. and the evening at 8.30 P.M.

A PRIZE of 1000 guineas has been offered by Messrs. Selfridge and Co., through the Royal Aero Club, for the first flight of fifty miles made by a British pilot on a British-built glider, the distance to be measured in a straight line from a given point of departure. The prize will remain open for a year from January 1, and if it is not awarded, a prize of five hundred guineas will be given for the longest flight of more than twenty-five miles during the year.

It is announced in *Science* that the Howard N. Potts Medal of the Franklin Institute has been awarded to Dr. Charles Raymond Downs and Mr. John Morris Weiss of New York "in consideration of their notable achievement in the scientific and commercial development of the catalytic vapour-phase oxidation of benzene to maleic acid and their pioneer work in developing a commercial process for changing aromatic to aliphatic compounds."

WE have referred in these columns from time to time to the preparations which are being made in France to celebrate the approaching centenary of the birth of Pasteur. British men of science have had an opportunity of sharing in the celebrations and we now learn from *Science* that the New York Academy of Medicine is organising an exhibition in commemoration of the event. The exhibition, which will be opened on December 27, will consist of a collection of books, manuscripts, photographs, engravings, etc., illustrating the life and work of Pasteur, and will conclude with a number of addresses by distinguished members of the medical profession.

A NEW Danish expedition to the Sahara is announced in the *Times*. Under the leadership of Prof. Olufsen, the expedition will shortly leave Tunis for the Shattel-Jerid. From Nefta it will go by Tuggurt to Wargla in the Algerian Sahara, and thence to Insalah, and endeavour to explore the Hoggar Mountains. The members of the expedition will include Dr. Gram, botanist, Drs. Storgaard and Kayser, geologists, and Prof. Bourcart, of the Sorbonne. Dr. Olufsen expects that the journey will occupy some six months.

NEWS from Mr. K. Rasmussen brings the story of his researches in Baffin Land and the Hudson Bay region down to the end of July. According to the *Times* the winter work was carried out according to programme. Surveys were made of the north coast of Fury and Hecla Straits, and that part of Baffin Land between Gifford Bay and Admiralty Inlet. Mr. Rasmussen himself was chiefly engaged in his

researches on the migration routes of the Eskimo, and in order to become acquainted with the local dialect stayed several months in a small Igdlulik settlement at Cape Elisabeth. At the end of March Mr. Rasmussen, with two companions, left for Chesterfield Inlet on his way to the Aivilik and Netjilik tribes. Baker Lake was reached early in May and Yathkied Lake in June. From there the party returned in July to Chesterfield Inlet. The country between Chesterfield Inlet and Yathkied Lake is inhabited mainly by pronounced inland tribes of Eskimo who only during recent decades have begun migration to the sea coast. They live on bad terms with the nearest Indian tribes, and some of them had never seen white men. Their legends often agree in minute detail with the Greenland legends: their religion is on a much lower level. Mr. Rasmussen considers these tribes to be the most primitive that he has ever met: this is also shown in weapons, houses, and boats. Everything connected with the sea is taboo. The stone houses are unheated, as no blubber is available. Salmon fishing and reindeer hunting are the only means of livelihood, and starvation is not an uncommon experience of these tribes. Steensby's theory that the Eskimo were originally inland American people receives support from these discoveries. The inland tribes which Mr. Rasmussen studied very likely may be the last survivals of the primeval Eskimo who have not yet reached the sea.

PROF. LEONARD HILL delivered a Chadwick Public Lecture on "Ventilation and Atmosphere in Factories and Workshops" on October 26. Prof. Hill emphasised the fact that it is not the relative humidity that matters, but the actual vapour pressure of the air coming in contact with the skin; the breathing of cool air entails more evaporation from the respiratory membrane and consequent greater outflow of lymph through the secretion of fluid from it. Thus the membrane is better washed and kept clean from infecting microbes. The open-air worker is thus better protected, and moreover escapes the massive infection from carriers which occurs in shut-up rooms. Wet-bulb temperatures in factories and mines are physiologically more important than dry-bulb temperatures; the velocity of the air is an important consideration, for on this chiefly depends cooling by convection and evaporation. The cooling and evaporating powers of an atmosphere can be measured by the kata-thermometer, a large-bulbed spirit thermometer. Furnace- and engine-rooms should be ventilated by fans at the bottom of wide trunks down which cool air naturally sinks, the fan breaking up the air into fine streams. Rooms are best ventilated by open windows or a system of fans to impel cool fresh air through gratings about eight feet from the ground and extract it through apertures in the ceiling; floors and walls should be warmed by radiant heat from gas or coke fires.

THE Eastman Kodak Company of New York has issued the fourth volume of "Abridged Scientific Publications from the Research Laboratory of the

Eastman Kodak Company," a volume of about 340 pages. It includes abridgments of 54 papers that have been published during the years 1919 and 1920 in various scientific journals and the proceedings of scientific societies. The abridgments are not mere expansions of the titles, as is too often the case just now, but useful and often long abridgments giving details of methods and results. At the end of the volume there is a complete list of all communications issued by the Laboratory (a total of 117), and indexes of authors and subjects for the four volumes. The subjects dealt with cover a very wide range. Besides those that are obviously related to photography, which are divided into nine sections, there are papers on photometry, colour measurement, sensitometry, photographic optics, physiological optics, chemistry, physical chemistry, electro-chemistry, colloids, and radiography. The volume is undeniable evidence of the activity of those who work in this Laboratory and of the broad views taken of the subject by the Director.

WITH reference to Dr. Hale Carpenter's letter describing a waterspout published in our issue of September 23, p. 414, we have received a letter from Mr. E. R. Welsh, Devon, Pa., U.S.A., in which he suggests that in a waterspout, centrifugal force would cause a partial separation of air and waterdrops, the waterdrops tending to concentrate in an outer sheath, while within the sheath there would be a region with lower waterdrop content; the continued existence of the central core would be provided by the uprush of spray from the surface of the water. Mr. Welsh suggests that the appearance of pulsation in the outer sheath might be explained by the rotation, combined with a spiral fluting of the sheath.

IN his presidential address before the Institution of Automobile Engineers, Colonel D. J. Smith warned the members that they must not allow themselves to be engrossed entirely in the technical aspect of the motor car; there are many other questions which might have a great effect on the well-being of the industry. He urged upon automobile engineers the necessity of not being content to design a car which would run on the comparatively good roads in this country. The local conditions in the various parts of the British Empire should be ascertained and steps taken to design cars to meet these conditions. The most suitable vehicle for any market captures that market, price being a secondary consideration. Col. Smith believes that the chief development in Great Britain would lie in the direction of vehicles carrying fourteen to sixteen people and luggage, which could compete with the railways in providing rapid and frequent passenger service, and so opening up rural districts in a manner not hitherto contemplated. He also criticised strongly the present methods of road construction, and likened the result to that which would prevail if the track of the L. & N.W. Railway were maintained by the 2 different borough councils of the areas through which the track passes between London and Scotland, each employing its own unemployed and using local unsuitable material. In connexion with the carrying capacity

of roads, the reduction due to tramway services was mentioned—a five minutes' service reduces the carrying capacity by 50 per cent., and a two minutes' service by 80 per cent. The country cannot afford tramways, and their comparatively early disappearance is certain. In reference to standardisation, Col. Smith urged that standards once decided upon should be used, and condemned the conception that a design would lose individuality by the adoption of standardised parts. Again, automobile engineers should not consider liquid fuel as the only fuel available. In many countries charcoal is available at prices which make it equivalent to petrol at a few pence per gallon. There is a need for a steam vehicle suitable for such fuel, and of a lighter type than those generally seen.

THE *Journal of Pomology* is to be made, in effect, the official organ of the horticultural research stations in England, and with this change the name of the journal will become the *Journal of Pomology and Horticultural Science*. Its scope will be widened

and it will be under the control of a publication committee consisting of Prof. B. T. P. Barker, Horticultural Research Station, Long Ashton, Bristol; Prof. R. H. Biffen, Horticultural Research Station, Cambridge; Mr. E. A. Bunyard, Maidstone (Editor); Mr. H. E. Dale, Ministry of Agriculture; Mr. R. G. Hatton, Horticultural Research Station, East Malling, Kent; and Mr. H. V. Taylor, Ministry of Agriculture. The research stations at East Malling, Long Ashton, and Cambridge have assumed financial responsibility. It is anticipated that four numbers of the journal will be issued annually, the first of which will be ready this month.

A VERY comprehensive catalogue of works dealing with chemistry in all its branches has just been published by Messrs. Wheldon and Wesley, Ltd., 2 Arthur Street, New Oxford Street, W.C.2. Nearly 3000 publications (many of them rare) are listed under some 44 headings. Being carefully classified according to subjects the list should certainly be seen by readers of NATURE interested in chemistry.

### Our Astronomical Column.

LARGE METEOR OF OCTOBER 17.—Mr. W. F. Denning writes: "This remarkable meteor was observed at Bristol, and also by Mr. W. Tidmarsh at Exeter at 11.46 P.M. on October 17. The radiant point was at  $152^{\circ} + 39^{\circ}$ . The luminous flight of the object was unusually long, and extended from over Stafford to a point in the English Channel about 30 miles south of Plymouth. The radiant point being near the horizon, the course through the atmosphere was almost parallel with the earth's surface. Its height declined from 71 to 62 miles, the path being about 225 miles long and the velocity 37 miles per second.

"This meteor was very similar in many respects to brilliant meteors which appeared on October 15, 1902, and October 22, 1919. Their radiant points were at  $150^{\circ} + 43^{\circ}$  and  $156^{\circ} + 39^{\circ}$  respectively. The comet of 1739 has a radiant point at  $157^{\circ} + 39^{\circ}$  on October 22, and may well have supplied the three bright meteors referred to above."

VARIABLE STARS.—Owing to the completeness of the data of variable stars of long period which are being sent in to Mr. Leon Campbell by his host of energetic observers, the Harvard College Observatory Bulletin, No. 776, announces that it is possible to estimate the approximate magnitudes of most of these stars for any given date several weeks ahead. It is therefore proposed to make the predictions one month in advance and to publish them bi-monthly. This arrangement is very satisfactory, because those who do not possess large instruments will be able to observe some stars when they are brighter than a certain magnitude, and will know when to commence the observations. Again, many of these stars are most interesting spectroscopically, and they can be followed when it is known that they are bright enough for the particular instrument the observer possesses. In this publication the variables are published in groups according as they become brighter than a certain magnitude after a certain date. Thus the date chosen here is November 1, 1922, and the variables are grouped as follows: those that will be brighter than magnitude 8.0; those that will be between 8.0 and 10.0; 10 and 12; 12 and 14; and fainter than magnitude 14.

THE DISTANCE OF THE CEPHEID VARIABLES.—Prof. Kapteyn and Mr. van Rhijn examined the proper motions of the galactic Cepheids of short period, and concluded that their distances were only about one-seventh of those given by the formula of Prof. Harlow Shapley, employed in Prof. Shapley's researches on the distances of the Globular Clusters. He replies to their paper in Circular 237 of Harvard College Observatory, giving reason to believe that the stars in question have unusually high linear velocity, which would affect the parallax derived from the proper motions. He shows that their apparent drift is not directed away from the solar apex, indicating that they have independent velocity. In several cases the spectroscopic has confirmed this, the velocities 50, 51, 193, 74, 49 km./sec. being found in five cases. Shapley then quotes the recent work at the Sproul Observatory, where the parallaxes of the Cepheids have been trigonometrically examined, the results confirming the spectroscopic parallaxes. These stars are concluded to belong to the stream of high-velocity stars, found by Adams, Joy, and Strömberg at Mt. Wilson to have a space velocity of some 200 km./sec. Since this is comparable with the average line-of-sight velocity of globular clusters, it is conjectured that the galactic Cepheids may originally have been members of the same cluster, and be merely travellers passing through the solar cluster.

The spectroscopic parallaxes agree closely, star-for-star, with those based on the period-luminosity curve, which strengthens the case for the adoption of the latter.

NOVA SCORPII 1922.—This object was discovered at Arequipa by Miss Cannon. On July 1 it was invisible and less than magnitude 12.5. On July 11, 12, and 17 its magnitude was 10.5, 10.0, and 9.9 respectively, the latter being the maximum; on August 2 it had fallen to 10.2, and on August 21 (Harvard) to 11.4. The spectrum is of the Nova type; bright bands were probably absent on July 12, but certainly present on July 25. Search on plates made in former years shows no star as bright as magnitude 15 in the position.

## Research Items.

**THE CREEK INDIANS.**—Mr. I. R. Swanton, in Bulletin 73 of the Bureau of American Ethnology, has followed up his study of the Indian Tribes of the Lower Mississippi valley (Bulletin 43) by an account of the Indians of the Creek Confederacy, about 9000 of whom were enumerated in 1910. This report does not deal with field work among the tribe, which is reserved for later publication, but is an attempt to gather from documentary sources an account of their movements from the earliest times until they are caught up into the stream of later history, in which concealment is practically impossible. It justifies the author's claim that it is an encyclopædia of information regarding the early history of the south-eastern Indians. A full bibliography and good maps will do much to assist the student of the ethnology of the American Indians.

**THE STUDY OF FINGER-PRINTS: IDENTIFICATION OF COWS.**—In the fourth number of *Dactylography*, a journal devoted to the study of finger-prints, Mr. C. L. Enos, superintendent of the State Bureau of Criminal Identification, Colorado, states as the result of his experiments that, as the human being can be identified by his finger-prints, it is reasonably certain that the pattern or design which Nature has provided at the end of every cow's nose may be made to serve the same purpose. Up to the present no precise classification has been worked out, and this will be necessary before such prints can serve a practical purpose. The noses of several calves have been printed each month for one year, and if further experiments show that these patterns persist during the life of the animal, it will supply a practical means of identification which will be valuable to all breeders and to the police.

**THE MUSIC OF THE UTE INDIANS.**—Miss Frances Densmore, well known by her previous studies of the music of the Chippewa and Teton Sioux tribes, contributes an account of that of the Ute tribe in Bulletin 75 of the publications of the Bureau of American Ethnology. This tribe, the origin of whose name is disputed, formerly occupied the entire central and western parts of Colorado and the eastern part of Utah, including the eastern part of Salt Lake valley and the Utah valley. The present work concerns only the Northern Utes, living in reservations in north-eastern Utah. They used to live in *t tipis* covered with elk hides, but now log huts are extensively used in winter. They have never been a warlike tribe, but their tenacity of opinion has repeatedly brought them into contact with the Government; their characteristic is quick transition of mood concerning matters of secondary importance. The author gives a good account of their musical instruments, and has collected a number of songs—those of the Bear dance, Sun dance, Turkey dance, war songs, those used in the treatment of the sick and in connexion with games—which will interest both the student of music in the lower culture and the anthropologist.

**JAPANESE PLEISTOCENE FOSSILS.**—Some time ago we directed attention to a memoir by Prof. M. Yokoyama on fossils from the Lower Musashino Beds (Red Crag age) from the Miura Peninsula, Japan (*NATURE*, August 26, 1920, p. 836). To the same author we are now indebted for another valuable memoir (*Journ. Coll. Sci. Tokyo*, vol. 44, art. 1), this time on the Mollusca and Brachiopoda of the Upper Musashino Beds of Kazusa and Shimosa, to the east of Tokyo, that he considers to be of Upper Pliocene or even

newer age, since the shell layer is near the top of the formation. There are 335 species described and a careful table of their distribution given, with notes as to their occurrence elsewhere, living or fossil. From this it is seen that six species are also found in our English Crag, one in the Pliocene of Italy, and several in North American Upper Tertiaries and Post-tertiaries. No less than 103 species are said not to be known living, while some 113 species are described as new, and, with many others, figured excellently on the seventeen appended plates. As in the case of the previous monograph, the nomenclature will not always pass muster with adherents to the international rules for zoological nomenclature.

**FOSSIL VERTEBRATES IN CENTRAL ASIA.**—More than twenty years ago a Russian geologist, W. Obrutschew, observed an extensive freshwater formation between Urga and Kalgan in Mongolia. He obtained from it the remains of a rhinoceros of middle or late Tertiary age. In the early part of this year, Messrs. R. C. Andrews and W. Granger, of the American Museum of Natural History, through the generosity of several friends of the Museum, were able to visit the same region and explore the formation more thoroughly. A preliminary report of their results is published by Prof. H. F. Osborn in the September number of *Asia*, the American magazine on the Orient. It now appears that the freshwater deposits represent a long period, and contain numerous fossil bones. The lowest horizon, apparently of Upper Cretaceous age, yields remains of dinosaurs closely related to those of the same age found in North America. They include iguanodonts, megalosaurians, and small running dinosaurs allied to *Ornithomimus*. Crocodiles and turtles are associated with them. The next horizon is evidently of Eocene age, and contains remains of hoofed mammals, some being small lophiodonts and others much resembling the peculiar titanotheres which are found in the Eocene of North America. In a still higher horizon there are large land tortoises, carnivorous mammals, and rhinoceroses, besides a gigantic rhinoceros-like mammal which may be related to the *Baluchitherium* discovered by Mr. Forster Cooper in Baluchistan. The collection which has been made will add greatly to our knowledge both of reptiles and mammals and of their geographical distribution. Geologists and palæontologists will await the detailed descriptions with interest.

**ECOLOGY OF "FLOATING ISLANDS."**—"Floating Islands," on which little colonies of vegetation maintain an independent, if precarious, existence, cut off from all connexion with the mainland, early attracted the attention of travellers, and have been reported from lakes, rivers, and the open sea. One of the earliest references is made by Herodotus to the floating islands of the Nile, and an interesting Japanese study by Harufusa Nakano (*Journ. Coll. Sci. Tokyo*, vol. 42, art. 3) quotes early Japanese and Chinese references, the earliest Chinese citation dating from about A.D. 300. Nakano shows that these floating islands may be found on inland waters in both the Northern and Southern islands of Japan. He traces their origin to various causes. Sometimes pieces are isolated from an indented coast-line by various factors active in erosion, as ice formation or frequent changes of water level; these pieces ultimately break adrift and float away. In other cases plant communities build themselves up from the shallow lake bottom and appear above water away from the land, ultimately losing their root anchorage and floating free; such

islands are usually almost pure colonies of one species, as the islands of *Typha japonica* or *Zizania aquatica*. Another type of island consists mainly of one species of a free-floating plant, such as the islands of *Eichhornia crassipes*. A very interesting case is reported by Nakano from the shallow lakes found in high moorland regions. Here masses of peat, crowned with vegetation, may be raised from the bottom of the lake in large part by the gaseous products accumulated from decomposition processes, in part by the buoyancy of the tissues of the living plants; such islands may be recurrent, sinking and rising in different seasons. Floating islands are gradually leached of any humus or mineral nutriment they may originally possess, so that their base is ultimately mainly a tangle of roots and fibre. It is to this cause that Nakano traces the gradual disappearance of some of the colonists prominent on the newly formed islands, such as *Phragmites longivalvis*, not as Pallas has suggested for the "Plav" on the waters of the Danube (Journal of the Linnean Soc., vol 43, 1916) to the degeneration of a vegetatively propagated plant.

NEW MAPS OF THE GOLD COAST.—The Survey Department of the Gold Coast, which was closed during the war, was reopened in 1920 under Lieut.-Col. R. H. Rowe. Work has been pushed forward so rapidly that about 15,000 sq. miles have now been surveyed and the publication of the maps has begun. The sheets, which are printed by Messrs. W. and A. K. Johnston, are on a scale of 1:125,000. Relief is shown by brown form lines at an interval of 50 feet. Water features and names are in blue. Green is used for forests, and various symbols are employed to show the different kinds of plantations. Seven classes of roads and tracks are shown. Soundings in coastal waters are given in fathoms. The Accra sheet which has just been published is an excellent piece of work, and is notable both for its clarity and amount of detail. The same publishers have also produced a folding-map (scale 1:1,000,000) of the Gold Coast, Ashanti, Northern Territories, and British Togoland. No relief is shown. Colour is used for provincial and other boundaries, water features, and motor roads. This is a less striking map, but should prove useful for general reference purposes.

TROPICAL CYCLONES IN SOUTHERN HEMISPHERE.—A summary of tropical cyclones in the South Pacific, Australia, and the South Indian Ocean, by Dr. S. S. Visher, is given in the U.S. *Monthly Weather Review* for June. For the South Pacific 246 hurricanes are discussed. The hurricane season extends from December to April, and during this period about 95 per cent. of the recorded storms have occurred; January alone has 30 per cent., while the six months from May to October make up only 4 per cent. of the total. A table gives the frequency of occurrence in the several island groups. A second table shows the number of hurricanes between the longitudes 160° E. and 140° W. for the several months and years, consecutively for the years 1830 to 1922. There is a further table which gives approximately the region of the origin of cyclones in the South Pacific, which shows a prevailing majority between 15° and 20° south latitude. Similar tables are given for recorded hurricanes, between 100° and 160° E., for Australia and adjacent waters. The maximum number of the approximate origins or places of first record occurs between 10° and 15° S. The main season for the Australian hurricanes is from December to April, and during this period about five-sixths of the storms occur. Storms are rare from May to November. Of the tropical storms in the South Indian Ocean, both

January and February have 25 per cent. each and March 20 per cent. of the total. Storms are extremely rare from June to September. On the average rather more than a dozen tropical cyclones occur annually in longitudes 40° to 100° E. There is generally a preponderance of storms during recent years in the three regions, doubtless due to an increased number of observations. Representative tracks are well illustrated on two charts. The author states that many widely accepted generalisations as to tropical cyclones appear unsafe in the light of fuller data being gathered.

TREATMENT OF TIN AND TUNGSTEN ORES.—The Tin and Tungsten Research Board, under the chairmanship of Sir T. Kirke Rose, has recently given an account of the work done during the period January 1918 to December 1920, when its activities came to an end (Department of Scientific and Industrial Research. Report of the Tin and Tungsten Research Board. Pp. vi+100. London: H.M. Stationery Office, 1922. 3s. 6d. net.). As a useful introduction to the papers dealing with the various investigations that have been carried out, an account is given by F. H. Michell of the methods already in use for dressing tin ore in Cornwall, and E. H. Davison gives a report on the microscopic examination of veinstones. The ore-dressing investigations include work on flocculation-effects and friability tests by S. J. Truscott and A. Yates, and an investigation by H. S. Hatfield of various physical properties in relation to concentration possibilities. Hatfield found that the osmose process was inapplicable to the separation of cassiterite. He also found that there is little prospect of increasing the yield on the dressing floors by the addition of flocculating agents to the pulp. His work on dielectric constants as a basis of separation is novel and interesting, depending as it does on a property which, like magnetic permeability, is characteristic of the whole mass of a mineral particle and not merely its surface, and is applicable to minerals generally. Other researches, by Sir T. Kirke Rose, J. H. Goodchild, and others, deal with chemical and metallurgical methods, including the use of solvents to remove cassiterite or wolfram by direct solution, the conversion of cassiterite or wolfram by furnace methods into a soluble product, followed by leaching, and the removal of the tin or wolfram from ores by volatilisation, followed by condensation. The report thus deals with many aspects of ore-treatment. It gives a large amount of information which will doubtless receive due attention by those interested in the Cornish tin-mining industry, and will presumably be put to the test so far as is practicable when the mines re-open.

SEPARATION OF ISOTOPES OF CHLORINE.—In the *Memoirs of the College of Science of Kyoto Imperial University*, vol. iv., No. 7 (March 1921), Dr. Ishino describes experiments with the crossed deflection positive ray method, in which a separation of chlorine into isotopes was obtained. The paper was received on July 22, 1920, and the work was completed in September 1919. Dr. Ishino made experiments to see if the separation of the parabolas (which are clearly shown in the plates) was due to impurities, and was able to show that this was not the case. He found the atomic weights of the two isotopes to be 34 and 36; a line, 37, was due to hydrochloric acid; the other hydride (35) had no corresponding line, but the broadening of the line 37 seems to show the existence of such a hydride. The connexion with the "whole number rule" and the helium nucleus is pointed out.

### The Peril of Milk.

By Prof. HENRY E. ARMSTRONG.

A CONFERENCE of a most important and serious character was held in the Council Chamber of the Guildhall, London, on October 16-18, during the week of the Dairy Show, dealing with our milk supply in practically all its aspects—except the scientific! Yet we speak of science as salvation, perpetually proclaim its importance, and deplore public apathy towards its priesthood. Our class was not invited to participate. I heard of the conference only casually and bought myself in, only at the very last moment; consequently I was relegated to a place in the gallery behind the speaker's chair, where I could not hear a word. Being unobtrusive in my ways, I descended to the floor and trespassed into a vacant seat; the platform was all but empty but no invitation to take a chair upon it came down to me. I do not wish to complain but merely point out the rewards of scientific service and the effusive way in which the man of affairs welcomes our aid.

I make this statement, indeed, just to show where we are in public esteem, when subjects of vital importance to the national welfare, with which we alone can deal effectively, are under discussion—nowhere! Whose is the fault? Our own! We are mouldering away in our laboratories and when we seek to make known what we have been doing use a jargon which we cannot ourselves understand. That we have a public duty to perform seems never to occur to us. Much of our so-called research work is very largely wasted effort, without any real intelligence behind it—without policy and without imagination. The real problems are all but untouched.

Our knowledge of milk is practically nil—this was made clear at the conference. As the result of our careless abstention from the affairs of the world, sentiment and commercialism are quietly, without hindrance, wreaking their will upon the country. Few are aware, I think, of the extent to which milk is ceasing to be milk as the cow gives it: how it is being tampered with to overcome initial avoidable carelessness, to make it keep and to satisfy the indiscriminating animus against micro-organisms engineered into existence, of late years, by bacteriologists. Apart from the wonderful livestock, the feature of the Dairy Show was *Pasteurising* plant. One of the most interesting of these is to be operated at 135° C.!

I was the first to take the floor after the opening paper was read, dealing with breed of cattle in relation to quantity, composition and cost of milk production. I deplored the absence of the chemist and insisted that we know nothing of the composition of milk in any proper sense of the term—that to talk of it in terms of fat and solids-not-fat was equivalent to describing a house in terms of percentages of bricks, mortar, wood, etc. Modern discovery had taught us that the essential value of milk lay in certain mysterious minor constituents which could neither be identified nor quantified—yet were of most vital consequence: which I would term *advitants*—to catch the public ear, maybe *vitalites* were better—but refuse to misname vitamins.

To justify Pasteurisation, we have to show that no harm is done to milk by heating it above bloodheat. To heat it above this temperature is to treat it *unnaturally*—this cannot be gainsaid. That it is altered thereby is proved up to the hilt. The contention is that, by making a certain addition, we can compensate for the alteration—but we have only superficial evidence in favour of this contention. The medical profession has only recently had its attention

directed to these matters—it does not know yet what to look for. The effects may be deep-seated, we know; and they may come but slowly under notice. Time alone, combined with the most refined study of the problem, can prove that it is safe to trespass beyond Nature's limit. The second teeth, we know, are formed at birth; scurvy affects their structure ere change be noticeable externally; and so it may be in other cases. The bad teeth of our nation are probably, at least in large part, due to defective nutrition in early years and they affect us throughout life. Nations whose children are all breast-fed have good teeth.

The only rational assumption to make is that no constituent of milk is without a purpose and that, if anything in it be destroyed, it loses in dietic value. The recent remarkable discovery, that a something secreted by the pancreas, no gross constituent apparently, is required for the normal metabolism of so combustible an article of diet as sugar, should be a warning against destroying any natural agent in a whole food like milk; especially in view of recent work by Gowland Hopkins.

At a time when we are beginning to know these things, we have no right to develop an unnatural practice and allow it to become general. We must gain much more knowledge before making up our minds. On all sides, at the conference, it was recognised that clean raw milk can be produced and purveyed, if we will but take a little care.

Scurvy, rickets, beriberi, we know, are diseases affecting us as consequences of malnutrition; scurvy became rife in Denmark early in the war, on the farms, when the children were fed on Pasteurised milk. Who shall say that a host of our minor complaints are not due to dietic deficiencies? Women are often most faddy feeders and the frequent appearance of nervous disorders in their sex may well be connected with lack of vital elements, even due to seed sown in infancy. We may be laying the foundation of complaints worse than cancer.

Who knows or does not know? At present we can *assert* nothing, either way, so crass is our ignorance: so let us halt while we may.

The effect of food on the cow's milk was more than once brought out at the meetings. We were told that milk from cows that had been stall-fed but grazed occasionally proved vastly richer in one of the *advitants* than that from animals simply stall-fed; also that two varieties of one root crop had different effects on the production of milk. Pigs apparently give healthy pork when grass-fed but not when inquired of green food. The whole field of food inquiry lies open before us. Prof. Stenhouse Williams—dairy bacteriologist at Reading College—and I were the only speakers to sound the note of nutritional danger from Pasteurisation. We stood alone. Rothamsted, which claims to stand at the head of agricultural research, was unheard; the Animal Nutrition station at Cambridge was voiceless. Sir W. Morley Fletcher, of the Medical Research Council, who took the chair at the discussion on Pasteurisation, had not a word to say by way of caution. The Medical Research Council, however, has never had a chemist among its members; and yet medicine is nothing but applied chemistry.

Where, we may ask, are the Prophets? Science is simply disgracing itself in this matter of milk: the call to wake up and defend the public health must go out everywhere.

## Indian Institute of Science, Bangalore.

ALTHOUGH only 203 students have worked for various periods in the laboratories of the Indian Institute of Science at Bangalore since its opening in 1911, and although only 14 of these have been regarded by the council as suitable for the diploma of associateship, the history of the Institute is of special interest to students of educational methods. The conditions affecting the activities of the Institute depart, however, so widely from the normal that it is impossible at this stage in its history to be sure whether any, and what, changes in the administration of the Institute would have resulted in more visible success. Bangalore, the site selected for the Institute by the late Sir William Ramsay, is mainly a military cantonment. Its position as a centre, either of scientific education or of technical industries, is almost negligible. The Institute itself occupies isolated ground far enough from the town to cut it off largely even from the limited social amenities obtainable in an Indian cantonment station. Distances in India are of the continental order, and university graduates, being generally married in early life, hesitate naturally to leave the established university cities to undertake post-graduate training at a distant institute which has no traditions, no connexions, and no established market value. Moreover, the number of science graduates qualified in India to undertake research work has hitherto been very small.

The machinery of government originally designed for the Institute reproduced some of the ordinary features of established universities, including a large "court," composed of widely dispersed members who have never even met as a body. Even the relatively small council is handicapped by the distance of some of its members, and its meetings have thus been largely controlled by the resident professorial members. Influenced by desire for a special review of progress by an entirely independent expert body, the standing Committee of the Court in 1921 requested the Governor-General in Council to appoint a committee of inquiry, which met towards the end of the year under the chairmanship of Sir William Pope, professor of chemistry at Cambridge; and the report of the committee recently made available forms a valuable study of this artificially created institution.

Hitherto the work of the Institute has been limited to two groups, which are distinct from one another in nature and method of training. In the department of pure and applied chemistry, students have been engaged in research problems; there has been, however, no systematic course of training, either by lectures or laboratory work. In the department of electrical technology, on the other hand, students have undergone a more systematic training, with the view of qualifying as practical electrical engineers. There has been no department of physics to link the other two, and no department of mechanical engineering on which to base the training in electrical technology.

Up to 1918 the annual income of the Institute amounted to something less than 17,000*l.*, but recently, owing to the sale on advantageous terms of the investments left by the founder, the late Mr. J. N. Tata, the income now available is nearly doubled.

The committee, in accepting the conclusion that the Institute has not fulfilled the just expectations of its founder, wisely refuses to discuss the merits of the specific complaints made against its administration, and limits its report to the discussion of proposals for reform. In the first place, the committee, after briefly reviewing the standard of scientific training obtainable at Indian institutions of univer-

sity rank, considers it desirable to establish, by lectures and laboratory practice in the Institute itself, definite courses of instruction which will lead the ordinary science graduate from the stage at which he usually leaves the average university college to that which will qualify him for systematic research.

Having given an outline of the fundamental policy to be kept in view, the committee proceeds to discuss plans for the logical expansion of the departments already established, assuming this to be preferable to the immediate introduction of additional branches of science. The scheme outlined contemplates the institution of eight professorships in branches of pure and applied chemistry, and these are to be linked with the now isolated department of electrical technology by a chair in general physics. It is proposed also to establish two additional chairs, namely, one in applied mechanics and another in thermodynamics, for the purpose of rendering more effective the training in the department of electrical technology. For the time being this scheme goes as far as it is safe to project future developments; even this will require a larger income than is now in sight. Indeed, two new chairs will practically absorb the present annual surplus, and the committee thus recommends that the first two chairs established to supplement existing activities should be preferably in chemistry and in thermodynamics and heat engines.

To create in other parts of India an extended interest in the Institute, the committee recommends a reconstitution of its government machinery. To the court it is proposed to add representatives of any new benefactors that may appear, as well as representatives of all the "reformed" Governor provinces, except Assam.<sup>1</sup> The committee proposes also to introduce a representative of each of the new legislative councils, Assam not in this respect being specifically excepted. These changes, the committee hopes, will create a friendly interest in the Institute in other parts of India; but the tendency (always manifest, and now decidedly strengthened by the recently reformed constitution) of developing provincial institutions may neutralise to some extent the committee's expectations in this respect. The only alternative plan of dispensing with such large controlling bodies introduces, however, dangers of the kind that, according to some witnesses, have adversely affected the development of the Institute hitherto.

The council now proposed as the body responsible for the determination of matters of policy, for finance, and for the appointment of a staff, includes the executive head of the Institute, who is styled principal in preference to director, together with eleven other members, composed of five nominees of the Indian universities, two of the Tata family, two of the Mysore State, one of the Indian Legislative Assembly, and a scientific officer to represent the Government of India. An explanatory paragraph in the report assumes that by this scheme the central government will be represented by two nominees, but the nominee of the Indian Legislative Assembly would be in no sense a representative of the Government of India.

For purely academic business it is proposed to establish a board of studies, composed of the principal, the professors, and certain other members of the staff.

The committee recommends that the principal should be a scientific man of eminence, with proved administrative capacity. This obviously wise prescription has been observed in the recent appointment

<sup>1</sup> We understand that the Government of India proposes to add to the government machinery of the Institute a representative of Assam and another of the newly constituted University of Delhi.

of Dr. M. O. Forster, although apparently it has not been found possible to combine these two qualities with "considerable Indian experience," which the committee regards as "almost essential."

Among the many difficult questions which the committee has carefully considered are: (1) The claims of local administrations on the services of the professorial staff for special investigations outside the Institute. Admitting the occurrence of exceptionally urgent instances, the committee thinks that any tendency in this direction to take members of the staff away from their immediate duties inside the Institute should be resisted. (2) The investigation of special technical problems for outside persons. These, the committee thinks, might be permitted under suitable control at the expense of the applicants, so long as a fee be also charged and be wholly credited to the Institute funds, no part of the fees thus obtained being granted to the salaried members of the staff who may undertake the work. (3) The committee considers that the higher staff should not accept any private practice which involves work to be carried out in the Institute laboratories, although it might be permissible for a professor to undertake purely consulting practice, subject to the approval of the council and with specified limitations. (4) While a member of the staff should enjoy the copyright benefits of any book of which he is the author, the committee is less decided about his taking out patent rights for inventions arising out of work done at the Institute. Each specific case of the sort which arises should be dealt with by the council on its merits. (5) Technical investigations in the Institute which successfully lead to work on a factory scale

(when, naturally, commercial interests intervene) should be stopped at this stage. In the opinion of the committee, the work should then be transferred to a commercial firm, which might, if necessary, employ members of the staff in a purely consultative capacity. (6) The Institute should not undertake routine analyses and determinations; these should be left to the private enterprise of outside chemical firms.

The committee thinks that the necessary co-ordination of the work of the Institute with that of Indian universities will be in part effected by the university representatives on the council and by more efficient publication of information regarding the activities of the Institute itself. It is suggested that the Journal of the Institute should be expanded to be made of more general interest; that the local organisation of an Indian section of the Society of Chemical Industry should be undertaken; that the staff should be encouraged, by the grant of travelling expenses, to take part in the annual meetings of the Indian Science Congress; and that a report on the research programmes in progress at the Institute should be submitted annually to the Indian Board of Scientific Advice.

Because of the isolated location of the Institute, the committee recommends an improvement in the hostel accommodation, especially for the benefit of married students, and generally an increase in the facilities for games and other social amenities. To ensure that progress is effected on sound lines, it is recommended that the Governor-General in Council as visitor should institute, once in every quinquennium, a review of the operations of the Institute by a special committee of inquiry.

### Psycho-Analysis and Education.

THE place of psycho-analysis in schools was the subject of a discussion at a joint meeting of Sections of Psychology and Education of the British Association meeting in Hull. The crowded meeting testified to the evident interest taken in the subject, and to the growing appreciation of the need in educational work of a closer co-operation between those who are responsible for the training of the young, and those who are making a scientific study of mind working and development.

It will be well at the outset to state that the term psycho-analysis was used by all speakers in the broad sense of mental exploration to discover, or at least trace, the mental history of the abnormal child, the cause of his mal-development, feeble intelligence, delinquency, or vicious conduct. In no case was the term used in the strict Freudian sense; in fact, Dr. Crichton Miller, one of the speakers, expressly stated that, in order to avoid any misconception arising from the use of a term that might imply exclusively the theory and technique laid down by Prof. Freud, he preferred to use the term analytical psychology.

Appearing first as a method of treating nervous disorders Dr. Miller said that analytical psychology has a wider function. Its real scope and value should be preventive, its application as universal as the accepted principles of hygiene, and its propaganda carried on by all who have a stake in the next generation. Hence its importance to teachers, and hence the necessity for teachers to understand and value it in their own experience.

The advent of analytical psychology marks a new era in education because it makes a new demand, that the teacher should know, not only his subject and his pupil, but himself. It follows that one of the chief functions of analytical psychology in education is not to enable the teacher to analyse his pupils—a

technical task for which he cannot usually have either the time or the training—but to help the teacher to recognise and remedy failures of character development in himself, the inherent childishness, the prejudice, and self-deception which are the chief obstacles to understanding children, and handling them wisely. If there are still teachers who maintain that analytical psychology is irrelevant to their work, Dr. Miller reminded them that their failures will come to be judged by analysts later who have to attempt the re-education of the adult who might have developed into a man, and instead developed into a neurotic.

Dr. C. W. Kimmins in opening the discussion presented the case from the schools point of view, and claimed that the time was singularly opportune for a clear statement by the experts of the possibilities, and limitations, of the part a well-qualified psychologist could take in the appraisal of intellectual values, and in helping to solve those complex problems presented by the abnormal child.

The improvement attending the use of intelligence tests in the selection of children for promotion over the method of marks gained by the usual examination method has already been demonstrated, and there is no doubt that in the greater freedom of the child, and the fuller scope it has of self-expression and self-development under the Montessori system, the Dalton plan, or any other similar form of school organisation, many of the so-called psycho-pathological cases would disappear. But the child that will not respond to normal methods of instruction or treatment will probably always exist. The boy who has no apparent mental or physical defect, is interested in out-of-door life and plays games but shows no interest in instruction, and is always at the bottom of the class, is an educational failure, and a case for the psychologist. A day-dreamer is another type.



These Dr. Kimmins would have treated at psychological clinics such as are already established in the United States, America, and other countries, in which very useful results have been obtained. He also suggested that if the teacher had a fairly sound knowledge of his own personal equation it would greatly increase his efficiency.

Dr. Hamilton Pearson claimed that the practical application of psycho-analysis had a place in school routine with two reservations, namely, that the operator should be not only a trained analyst, but should have special experience in child analysis, since the technique is different, and the work altogether more difficult and delicate than with adults; and secondly, that the limitations of the field of application within the radius of our present knowledge are thoroughly understood. In helping to define those limitations it may be taken as a rule that no child showing normal development, adapting adequately and progressively to its environment, should have even a nodding acquaintance with analysts. The rigidity of a systematised educational scheme must of necessity fail to win response from a minority of children, and this coupled with an adverse family environment accounts for the mal-development of the few. Among this group of potential neurotics, criminals, and chronic failures lies the sphere of usefulness of the child analyst.

Dr. Pearson declared that analysis itself is not curative, but by exposing the causal factors of the mal-development it is a means of pointing the way to constructive methods of treatment. He described three cases in which analytical methods had been used, to illustrate how they had been treated. The subsequent history of each child showed how by co-operation with the teacher a definite cure had followed. He believed that in co-operation lies the future of psycho-analysis in its practical value to school life, and that the knowledge gained in dealing with the abnormal would be of inestimable importance in dealing with, and understanding, the normal.

Dr. R. G. Gordon endorsed the value of co-operation of the workers in the fields of education and psychology, and also emphasised the necessity that such problems should be dealt with only by people whose knowledge is extensive, and embraces such collateral subjects as physiology and biology. He protested strongly against the unqualified dabbler with his pseudo-metaphysical speculations which are not even logical.

Dr. Gordon described two types of children likely to give trouble, namely, the psycho-pathic child, and the retarded child who is yet not sufficiently feeble-minded to be classed as mentally deficient. Every child inherits certain predispositions, and some dispositions unmodified or uncontrolled are evil and lead to vicious conduct, but if properly correlated, and modified by each other, and by education, they are all capable of leading to the highest virtues. It is the uncontrolled impulses which characterise the

behaviour of the moral deficient, such as an overmastering impulse of acquisitiveness and a complete failure to get into touch with reality.

The retarded child is a slightly different problem. If with an intellectual inferiority he possesses a nature in which self-assertion is a large factor, he will not submit to inferiority—superiority at games may save his self-respect, but in their absence his will to assertion may show itself in acts of rudeness, disobedience, or stubbornness. To avoid punishment he becomes a liar; to prove his independence he plays truant; and possibly to further his object he may steal money, etc. Other undesirable traits may exhibit themselves in his efforts to gain ascendancy over other children. In many cases it is only necessary to remove such children from the unfair competition involved in school, and start them in training suited to their intellectual capabilities. Not only will this do away with all vicious tendencies, but it will increase their achievement to a remarkable degree, so that they grow up not incapable of taking a worthy place in the world. Neglect of proper treatment for such children means that they eventually enter the ranks of the neurotic or the criminal, or may turn to drink or drugs which lead to an abased and useless life. It is obvious that investigation and treatment of such cases should be definitely undertaken both for the sake of the individual and of the State.

The investigation should be carried out in three directions: (1) the physical examination—a purely medical concern; (2) the intelligence estimate through the use of such means as the Stamford revision of the Binet-Simon tests, etc.; and (3) the child's reaction to life—requiring mental exploration. In the last case Dr. Gordon said if clinics are established it must be borne in mind that only properly qualified workers should conduct the inquiry. The mind of the child is a delicately adjusted mechanism and cannot be too carefully handled; the greatest care must be taken that nothing shall be implanted which shall still further weaken control and upset the nice adjustment of impulses on which his or her sanity depends. The functions of such clinics will at first be purely advisory, and here the importance of sound advice is obvious.

In schools of all types are to be found children whose moral sense and will to work are so impaired that their time at school and probably at home is a succession of misdemeanours and acts of viciousness, a continued refusal to adapt themselves to social order; they are deaf to all appeals to reason. The investigation of the problems set by these children seems to be rightly in the hands of the psychologist, and the present inquiry is to learn to what extent mental exploration in the form of psycho-analysis can save the child by pointing out the cause and thus suggesting the remedy. Every speaker expressed the opinion that this inquiry should only be undertaken by a fully qualified specialist and should be limited to those children who were abnormal in their behaviour and in their response to the usual incentives to work.

### Corrosion and Colloids.<sup>1</sup>

CORROSION is defined as the oxidation of a substance; it may be produced by chemical or electro-chemical means. The following facts are difficult to explain on a purely electro-chemical theory of corrosion: (a) Certain depolarisers do not increase corrosion, but actually inhibit it; (b) the conductivity of electrolytes is not directly connected with the amount of corrosion; (c) Lambert's pure iron is readily attacked by sodium chloride solution and dilute

acids; and (d) the presence of ions of the corroding metal sometimes increases corrosion. The order of corrodibility of metals in distilled water, certain salt solutions, and non-electrolytes is different from their order in the electro-chemical list; this suggests that there are factors interfering with the electro-chemical action. Such factors are scale formation, and the nature and distribution of the products of corrosion.

The effects of strain and impurity in the metal are considered on the electro-chemical view to be of fundamental importance. Experiments on Lambert's

<sup>1</sup> Abstract of sixth report of the Corrosion Research Committee of the Institute of Metals, presented by Dr. G. D. Bengough and J. M. Stuart at the Swansea meeting of the Institute on September 20.

pure iron and lead showed that the effect of strain is a minor and ephemeral factor in corrosion in neutral solutions; a trace of impurity appears to assist local corrosion, but the amount of corrosion is not proportional to the amount of impurity. The effect of a trace of impurity is probably a trigger action. The main function of oxygen in corrosion is not that of a depolariser, but rather to oxidise the metal directly, and also in some cases the products of corrosion.

Two chief types of corrosion are distinguished: (a) The general type, usually characteristic of acid corrosion; and (b) the local type, usually characteristic of corrosion in water and salt solutions. The latter is generally characterised by the formation of an adherent scale on the metal, which may contain colloid. The significance of colloids in corrosion appears to be as follows: A metal immersed in water sends positively charged metal ions into the liquid, and becomes itself negatively charged. With commercial metals, the metal also becomes superficially oxidised if dissolved oxygen is present. The hydroxide produced can take up the ions given off by the metal, and thereby becomes a positively

charged colloid. Some of this will diffuse away, permitting further reaction between oxygen and the metal surface. Oxidation stops until this hydroxide can pass into the colloidal state by acquiring positively charged metal ions. This, in general, does not take place till the colloid initially formed has diffused into the presence of electrolyte, when it is precipitated by the anion of the dissolved salt, the cation neutralising the charge on the metal corresponding to that on the colloid. Then the metal can send more ions into solution, and the uncharged hydroxide can acquire a charge. If the colloid produced can diffuse away, the process can continue and corrosion develop. If the colloid precipitates directly on the corroding surface it will, in general, adhere and stop corrosion. In the case of a corrosion pit, it is only when the colloid diffuses through an aperture in the gel-deposits at the mouth of the pit that it meets electrolyte and is then precipitated. Such precipitation merely thickens the external gel-deposits. The latter protect the metal surrounding the pit, and emphasise the local nature of the corrosion.

### Vitamins.

THE Sections of Physiology and Agriculture of the British Association held a joint discussion on vitamins at Hull on Friday, September 8.

Prof. J. C. Drummond spoke of the great strides that have been made since the discovery of the vitamins by Hopkins in 1912. Both the existence and the indispensability of these substances are now generally accepted. The far-reaching importance of the qualitative composition of the diet of man and animals is being gradually appreciated, and the significance of those factors which exist in extremely minute amounts recognised. Three substances of the so-called vitamin class have been differentiated with certainty, and it is possible that more exist. They do not appear to be of one chemical type, and the only ground for grouping them together is that they occur, and are effective, in very small amounts. Parallel examples from the inorganic food constituents are known, such as the value of minute doses of iodides in the treatment and prevention of foetal athyrosis in swine.

The green tissues of plants would seem to be the chief site of vitamin synthesis, although lower forms of plant life devoid of photocatalytic pigments can apparently produce the vitamin B. Plant tissues undoubtedly form the direct or indirect source of the vitamin supply of animals, but we are entirely ignorant as to the rôle of the vitamins in the plant itself.

Storage of the vitamin A may take place in the tissues, liver, and body fat of animals, and may serve as a reserve from which are drawn supplies to maintain the vitamin concentration of milk if the diet during the lactation period should be deficient.

In collaboration with Dr. Zilva a prolonged investigation of the origin of the large stores of vitamin A in cod-liver oils has recently been made. It has been ascertained that the marine diatoms synthesise the vitamin, and that it is transferred to the tissues of minute animals (plankton) which thrive on the unicellular plants. These in turn form the food supply of larger species, particularly small fish, which in their turn are devoured by the larger fish, such as the cod. Through all these stages there is apparently a transference of the vitamin, ending finally in the storage in the liver of the cod. The modern methods of manufacture of cod-liver oil do not appreciably lower the vitamin value, but

there are wide variations in the value of different samples which are probably connected with the seasonal changes in the feeding habits or physiological condition of the fish. Considerable work has been done on the chemical nature of the vitamin A, but an isolation has not yet been made. It is very stable, except to oxidative changes, and passes into the unsaponifiable fraction of the oil. Cholesterol, pigments, and other fractions of this fraction may be removed without loss of potency.

Capt. J. Golding gave a number of illustrations of the value of the application of vitamin theories in practical pig-feeding. Frequently the usual type of pig diet is deficient in vitamins, particularly vitamin A, and the beneficial influence of cod-liver oil or of feeding on pasture or lucerne in such cases is remarkable. In the compounding of rations care should be taken to ensure an adequate supply of food-stuffs rich in vitamins, otherwise there is danger of sub-normal growth, impaired resistance to infections, and disturbances of the power to produce and rear normal young. The majority of the cereal products are deficient in vitamin A, and the amount in the diet is not raised much by the use of separated milk. Such diets can be supplemented by small additions of cod-liver oil, 1-2 oz. daily for full-grown pigs, or by access to pasture. Cod-liver oil is also valuable in maintaining the vitamin value of the milk yielded by cows on winter rations in stall, which otherwise tends to fall. The administration of cod-liver oil, if of good quality, does not produce flavour or taint in pigs or milk and butter.

Dr. Atherton Seidell (New York) described his attempts at the separation of the vitamin B from yeast by chemical methods. By adsorption of the vitamin from yeast extracts on to fuller's earth, and extraction of the activated solid with alkalis under suitable conditions, considerable concentration of the active substance could be effected. The resulting extract when fractionated by precipitation with silver salts gave active fractions, but these have not yet yielded a pure substance.

Prof. W. D. Halliburton referred to the need for caution that enthusiasm for a new word such as vitamin did not overwhelm the importance of other dietary units. There must not be a loss of perspective in viewing the function of these newly

discovered substances. There is also need for further research on the nature of the substances (auxinones) which are believed to act as vitamins for plant growth.

Dr. Monkton Copeman agreed with the importance of vitamins for the young and growing organism, but questioned whether they are as important, or not actually deleterious, to the mature animal. In some researches which had recently been made under the auspices of the Ministry of Health, evidence had been obtained that patients suffering from malignant growths had received benefit from a course of feeding on dietaries deficient in vitamins. There was also a definite, if microscopic, fall in the Registrar-General's figures for cancer during the years of the war, when food restrictions were in force.

### British and American Fine Chemicals.

THE "Catalogue of Chemical Products" issued by the British Drug Houses, Ltd., is now so well known to chemists that there is little need to do more than direct attention to the new edition, issued on September 21, which includes several thousand chemicals, many of them recent additions. The firm caters not only for chemical laboratories, but also supplies an extensive range of requisites for microscopic work, such as stains, mounting media, embedding materials, liquids of known refractive index, etc. Special mention may be made of the list of about 50 indicators for which the catalogue gives a useful table showing the PH range in each case, including the universal indicator, a mixture to be used for determining rapidly and in one operation the approximate PH of a solution by the colour developed.

A new edition (No. 8) of the list of organic chemicals sold by the Eastman Kodak Co. in the United States has also been issued recently. It includes about 1400 products and has two good features which British firms might copy with advantage. It indicates, usually by means of the melting- or boiling-point, the degree of purity of the product, and states which materials have been made or purified in the firm's own laboratories. The American firm seems to realise the necessity of securing as quickly as possible a reputation for quality similar to that enjoyed by a few of the German makers before the war, and the features just alluded to have no doubt been introduced into their list with that object.

The Eastman list begins with an introduction in which, after recording progress, a frank appeal is made to chemists to co-operate with the company in making the United States independent as regards the supply of these essential materials, by indicating possible means of improving the quality, furnishing information as to supplies of new or rare organic chemicals available for purchase, and suggesting new materials for manufacture.

British manufacturers should realise that British chemists are equally interested in this matter so far as this country is concerned, and similar appeals in their lists would probably have an excellent effect. There are few research laboratories in which there are not residues of rare organic chemicals available for disposal, and most laboratories of university standing could, from time to time, do something towards supplying complex organic chemicals.

It has been urged against the Board of Trade lists drawn up under the Safeguarding of Industries Act that they "protect" many chemicals which, owing to the small demand and the cost of labour, can never be made in this country. The co-operation of university laboratories might also be a means of overcoming this difficulty.

### University and Educational Intelligence.

CAMBRIDGE.—Mr. E. C. Francis, Trinity College, has been elected Fellow and mathematical lecturer at Peterhouse. Mr. C. G. Lamb has been appointed reader in electrical engineering.

The allotment made in 1920 of 165,000*l.* for the endowment of the School of Biochemistry from the estate of the late Sir William Dunn has been increased by a further sum of 45,000*l.* It is of interest to note the allotment ordered by the Court for the subdivision of the total sum of 210,000*l.*, namely (a) 96,000*l.* for the site and building of the Institute of Biochemistry; (b) 18,000*l.* for equipment, maintenance, and improvements out of annual income; (c) 89,000*l.* for salaries and the expenses of research work out of annual income; (d) 7000*l.* for a fund to meet contingencies and unforeseen expenditure.

A studentship for study and research in the languages, literature, history, archaeology or art of ancient Greece or Rome or the comparative philology of the Indo-European languages is to be founded from a bequest under the will of the late Sir John Sandys, Public Orator.

MANCHESTER.—On Monday, October 30, Mr. Harold L. Cohen opened the Lewis Departmental Library in the Faculty of Commerce and Administration. This library, and also certain scholarships, have been provided from a gift by Messrs. Lewis with the object of encouraging co-operation between the university and the business community of the city. The Faculty of Commerce has made rapid progress during recent years, and it is hoped that university graduates may find increasing opportunities to demonstrate the value of a university training in commerce.

Mr. E. J. Sidebotham has been appointed honorary lecturer in public health, and Mr. G. J. Langley hon. assistant lecturer in physiology.

The following appointments have also been made: assistant lecturer in electrical engineering, Mr. L. S. Palmer; special lecturer in textile design, Mr. Henry Cadness; Osborne Reynolds fellow, Mr. F. D. Reynolds; Vulcan fellow, Mr. F. Heywood; Leech fellow, Mr. C. D. Hough.

ST. ANDREWS.—The University Court has now made an appointment to the chair of natural philosophy in the United College, which became vacant at the end of last academical year by the retirement of Prof. Butler. The new professor is Dr. H. Stanley Allen, of the University of Edinburgh. Dr. Allen was educated at Kingswood School, Bath, and Trinity College, Cambridge. Afterwards he held a post as assistant lecturer at the University College of Wales, Aberystwyth; he also did research work in physics at the Cavendish Laboratory, Cambridge, under the direction of Sir J. J. Thomson, and was in charge of Lord Blythswood's physical laboratory at Renfrew. In October 1905 Dr. Allen was appointed to a post in the physics department of King's College, London, where, after being lecturer for some years, he followed his chief there (Prof. C. G. Barkla) to the physics department in Edinburgh. In the course of his career Dr. Allen has had a varied experience of the teaching of physics, and he has made some notable contributions to the scientific literature of the subject.

THE following Parliamentary candidates for university constituencies have been returned unopposed:—Scotland: D. McCoig Cowan (N.L.), Sir Henry Craik (U.), and Sir George Berry (U.). Queen's, Belfast: Sir William Whitla (U.). Sir George Berry is the only new member from these two constituencies.

## Calendar of Industrial Pioneers.

**November 12, 1902.** William Henry Barlow died.—Appointed principal engineer of the Midland Railway in 1814, when thirty-two years of age, Barlow laid out the line from London to Bedford and was responsible for St. Pancras Station. He was also concerned with the Clifton Suspension Bridge, the second Tay Bridge, and the Forth Bridge. He was widely known for his scientific investigations of arches and beams, and in 1868 was made one of the committee appointed to investigate the applicability of steel to structures. He was a vice-president of the Royal Society, and in 1879–80 president of the Institution of Civil Engineers.

**November 13, 1903.** Josiah Vavasseur died.—One of the chief ordnance engineers of last century, Vavasseur invented in 1866 the copper rotating ring or band for projectiles of breech-loading guns, and subsequently did important work on the construction of built-up steel guns and on hydraulic mountings. In the Vavasseur mounting of 1877, the recoil was for the first time scientifically controlled by hydraulic buffers having a uniform resistance. The London Ordnance Works which he founded was in 1883 merged in those of Armstrong's at Elswick.

**November 14, 1830.** Henry Bell died.—The foremost pioneer of the steamboat in Europe, Bell, who was born at Torphichen, Linlithgowshire, on April 7, 1767, was apprenticed as a stone mason but afterwards became a shipwright and builder. In 1808 he became proprietor of a hotel and baths at Helensburgh on the Clyde and in 1811 ordered the *Comet*. In August 1812 this little craft began running between Glasgow and Greenock, and from this dates the beginning of steam navigation in Europe. The vessel was wrecked in 1820, but the engine was salvaged and is preserved in the Science Museum at South Kensington.

**November 14, 1905.** Robert Whitehead died.—The inventor of the automobile torpedo, Whitehead made his first torpedo in 1866 while holding a position in an engineering works at Fiume. Taken up first in 1868 by the Austrian Navy, experiments were carried out at Sheerness in 1870 and soon afterwards the torpedo was adopted by the British and other Governments.

**November 15, 1839.** William Murdock died.—Known principally for his discovery of lighting by coal gas and as the originator of a great industry, which in Great Britain alone consumes some 22,000,000 tons of coal per annum, Murdock was for many years the right-hand man of Boulton and Watt. He was first employed by them in 1777, and was sent to Cornwall to erect steam engines. In his house at Redruth in 1784 he experimented with a small locomotive and in 1792 lighted his house by gas. He was also a pioneer in the transmission of power by compressed air.

**November 16, 1911.** Engelbert Arnold died.—A notable contributor to the literature of electrical engineering, Arnold, after studying at Zürich, engaged in practical work in Russia. For a short time he was engineer to the Oerlikon works in Switzerland and from 1894 to 1911 held a chair at the Institute of Technology at Karlsruhe.

**November 18, 1814.** William Jessop died.—Trained as a civil engineer under Smeaton, Jessop was employed on some of the English canals, completed the West India Docks and constructed a railway in Surrey which was the first opened to the public in the South of England. E. C. S.

## Societies and Academies.

LONDON.

**Royal Society, November 2.**—Sir Charles Sherrington, president, in the chair.—Lord Rayleigh: Polarisation of the light scattered by mercury vapour near the resonance periodicity. White light scattered at right angles by dense mercury vapour is to a first approximation completely polarised. Ultra-violet radiation of the mercury spectrum line  $\lambda 2536$ , when examined immediately it enters mercury vapour in an exhausted vessel at room temperature, gives a scattered radiation which is slightly though definitely polarised. This polarisation has been observed to increase as the beam is filtered by penetration of a considerable depth of vapour. After penetration of 27.5 cm. of vapour the weaker polarised image had 60 per cent. only of the intensity of the stronger one, instead of 90 per cent. as at first. The radiation removed by the filtration appears to lie within a spectral range of about  $1/100$  Angstrom.—G. P. Thomson: The scattering of hydrogen positive rays and the existence of a powerful field of force in the hydrogen molecule. At a pressure of less than  $1/100$  mm., hydrogen positive rays of 10,000 volts mean energy suffer considerable small-angle scattering in a distance of 15 cm. This scattering is 10–20 times greater than would be expected on theoretical grounds. There must, therefore, be a field of force in the hydrogen molecule at distances of the order of  $10^{-8}$  from a nucleus which is much stronger than would be expected from the inverse square law. A subsidiary experiment throws great doubt on Glimme and Koenigsberger's "Stossstrahlen."—H. D. Smyth: A new method for studying ionizing potentials. Positive ray analysis is used to study the ions produced in a gas or vapour by the impact of slow-speed electrons of known energy. This requires that the density of gas be considerable where the energy of the impacting electrons is known, and as small as possible where the energy conditions are not known. In the case of mercury such a localisation of vapour density was obtained by using a unidirectional molecular stream similar to that employed in a mercury diffusion pump. Ions were produced by electrons from a hot filament, and after acceleration by a large electric field were analysed by a magnetic field. In this way the values of  $m/e$  were determined approximately. The experiments on mercury indicate the formation of doubly charged ions at  $10 \pm 2$  volts. The series relations of the enhanced spectrum of mercury are not known, but analogy with zinc and cadmium suggests an estimate in agreement with the above value. The conclusion is that the double ions formed at this voltage are the result of two impacts. Experiments at higher voltages indicate formation by single impacts. More highly charged ions were present in such small quantities as to make their identification uncertain even at voltages as high as five hundred. It was also impossible to identify a singly charged diatomic molecule.—I. Backhurst: Variation of the intensity of reflected X-radiation with the temperature of the crystal. General agreement only is found with the theories of C. G. Darwin and P. Debye. Aluminium: Very marked decrease in intensity was observed with rise of temperature, and fair agreement with P. Debye's theory obtained for the (100) and (222) spectra. Carborundum: A special furnace was constructed for temperatures up to  $960^\circ$  C. and no deterioration of the crystal was observed. The decrease in intensity with rise of temperature was

much greater for the higher-order spectra, and different curves were obtained for the  $K\alpha$  (333) and  $K\beta$  (333) spectra. Graphite: Only for the cleavage-plane reflection was it possible to obtain a definite temperature-intensity curve, and for the direction perpendicular to this plane an unusually high coefficient of expansion was measured. Diamond: No decrease in intensity was found that could be measured with certainty, and a very small thermal agitation would be expected on account of the diamond structure's great strength. Ruby and sapphire: An anomalous effect was observed, since the decrease of intensity of the (111) spectra was greater than that of the (222). This may be completely explained by assuming that the atoms of the aluminium pair remain in contact and do not share in the expansion of the lattice.—S. Datta: The absorption spectrum of potassium vapour. The principal series lines up to  $m=42$  have been observed as absorption lines and their wave-lengths accurately measured. The series equation shows satisfactory agreement between the observed and the calculated values, with the exception of deviations for the last few lines, for which a possible explanation has been given. The first seven members of the series have been resolved into their components. Besides the absorption of the lines of the principal series, new lines have been found to be absorbed at higher pressures, which seem to have no correspondence with the known lines in the emission spectrum. The combination lines  $1s-2d$  and  $1s-3d$  have been found to be absorbed, the first as a pair, confirming the presence of a satellite to the lines of the diffuse series. Their appearance in the absorption spectrum gives distinct evidence of contradiction of the selection principle.—K. R. Ramanathan: The molecular scattering of light in vapours and in liquids and its relation to the opalescence observed in the critical state. Three instances of light scattering by homogeneous media are known—opalescence near critical point, scattering of light by gases, and scattering of light by liquids. Experiments on scattering of light by ether, in vapour and liquid phases, at different temperatures from  $33^\circ\text{C}$ . up to critical temperature  $193.6^\circ$  and in gaseous phase from  $193.6^\circ$  to  $217^\circ$ , give results in accord with the Einstein-Smoluchowski formula and not with the Rayleigh law. The Einstein-Smoluchowski formula is inapplicable in immediate neighbourhood of critical point. The scattered light is markedly less blue here. Following the theoretical work of Ornstein and Zernike, from maximum value of intensity of scattered light the value of  $\epsilon$ , radius of action of ether molecule, is deduced to be  $4.6 \times 10^{-7}$  cm. Light scattered at right angles to incident beam is imperfectly polarised; ratio of weak component to strong is throughout nearly 1.2 per cent., in case of vapour, while in case of liquids, ratio is 8 per cent. at ordinary temperatures, remaining constant till about  $120^\circ$  and then falling off to about 1.2 per cent. at critical point. There is no change of imperfection of polarisation on passing through critical point. Correction due to this in the expression for intensity of scattered light is given.

## PARIS.

Academy of Sciences, October 16.—M. Albin Haller in the chair.—The president announced the death of F. P. A. Barbier, correspondent for the section of chemistry.—Maurice Hamy: The calculation of a double integral which occurs in the theory of the diffraction of solar images by a rectangular slit.—An. Bilimovitch: The lines of inertia on a surface.—Ed. Le Danois: The hydrology of the

North Atlantic. It is considered that the name Gulf Stream should be restricted to the return current from the equatorial region. The variations in temperature and salinity of the surface water are due to a seasonal phenomenon and not to ramifications of the Gulf current.—C. Raveau: Demonstration of Fresnel's law of æther drift, without reference to the relativity of time and space.—André Guilbert: The calculation of the attraction of electro-magnets.—Maurice Curie: The refractive indices of the phosphorescent sulphides. The refractive indices of phosphorescent sulphides of calcium, strontium, barium, and zinc have been measured directly by the observation under the microscope of particles of the sulphides in a transparent homogeneous liquid of the same refractive index. The values found differ considerably from the square root of the dielectric capacity and lend no support to the theory of P. Lénard.—L. J. Simon and L. Zivy: The neutralisation of tartaric acid by potash in presence of the chlorides of the alkaline earths. In the presence of calcium (or barium) chloride, the titration of tartaric acid requires the same volume of caustic potash solution for neutralisation with either methyl orange or phenolphthalein as indicator.—Albert Perrier and B. de Mandrot: The elasticity and symmetry of quartz at high temperatures. Flat plates were cut from quartz crystals in four directions: along the binary and ternary axes, then in two directions normal to the binary axis. The quartz plates were worked with optical precision and the flexures caused by a load at the centre determined for temperatures ranging from  $18^\circ\text{C}$ . to  $1140^\circ\text{C}$ . There is a rapid change in the value of Young's modulus at  $576^\circ\text{C}$ ., a rise of  $1^\circ$  increasing the modulus to three times its value. Aimé Azam: The origin and process of formation of the soils at the Hague.—Jean Mascart: The proportion of successes in weather prediction. The question as to what constitutes a successful weather prediction is discussed, and it is pointed out that many predictions are too vaguely drawn and cover too many possibilities. If the forecast is drawn in precise terms, weather prediction may be considered satisfactory if the proportion of successes is more than 60 per cent.—P. Bugnon: The systematic position of the Euphorbiaceæ. J. Beauverie: The "critical period of wheat."—L. Blaringhem: A sterile hybrid of spelt and rye.—Adrien Davy de Virville and Fernand Obaton: Observations and experiments on ephemeral flowers. Light has no action on the opening or closing of the corolla in ephemeral flowers, and hygrometric state has a very slight influence. The temperature is the main factor in these movements.—Marc Bridel and Mlle. Marie Braecke: Rhinanthine and aucubine. Rhinanthine is impure aucubine. Rhinanthine was extracted by Ludwig from the seeds of *Rhinanthus Crista-galli*, and aucubine was discovered by Bourquelot and Hérissé in the seeds of *Aucuba japonica*. Rhinanthine is regarded by the authors as a mixture of saccharose and aucubine, and experimental data are given in support of this view.—Fred Vlès: The variations of the hydrogen ion concentration in the neighbourhood of eggs undergoing division.—J. Legendre: The trophic rôle of birds as regards the culicines. Further studies on the part played by domestic animals and birds in the protection of man against insects (*Culex*, *Stegomyia*).—Paul Wintrebret: Movement without nerve and nervous movement of the embryos of Raia.—A. Gruvel: Two species of lobster from the coasts of Indo-China.—J. Dumas and D. Combesco: Dysenteric intoxication of the rabbit and cholera intoxication of the guinea-pig by ingestion of soluble dysenteric and cholera toxins.

## Official Publications Received.

- Journal of the College of Science, Imperial University of Tokyo. Vol. 42, Art. 3: Ökologische Untersuchungen der Schwimmsel in Japan. Von Haruura Nakano. Pp. 57. 1.50 yen. Vol. 44, Art. 1: Fossils from the Upper Musashino of Kazusa and Shimosa. By Matsui Yoshitane. Pp. 200+7 illus. 17 plates. 9.20 yen. Vol. 44, Art. 2: On some Japanese Freshwater Tricladia; with a Note on the Parallelism in their Distribution in Europe and Japan. By Tokio Kaburaki. Pp. 71+1 plate. 2.30 yen. (Tokio: Imperial University; Maruzen Co., Ltd.)
- Philosophical Transactions of the Royal Society of London. Series B. Vol. 211: The Breeding Places of the Eel. By Dr. Johs. Schmidt. Pp. 179-208. (London: Harrison and Sons, Ltd.)
- Actes de la Société Helvétique des Sciences Naturelles. 101<sup>e</sup> Session annuelle du 23 août au 1<sup>er</sup> septembre 1920 à Neuchâtel. 1<sup>re</sup> Partie. Pp. 206-55. (Neuchâtel: N. K. Sauerländer S. G.)
- Bulletin of the American Museum of Natural History. Vol. 46, Art. 10: The Locomotor Apparatus of certain Primitive and Mammalian Reptiles. By Alired Sherwood Romer. Pp. 517-606+plates 27-46. (New York: American Museum of Natural History.)
- Contributions from the Jefferson Physical Laboratory, from the Canada. Department of Electrical Laboratory, and from Colleagues and Former Students, dedicated to Professor Edwin Herbert Hall, for the Year 1921. Vol. 15 (unpagged). (Cambridge, Mass.: Harvard University Press.)
- The Institution of Civil Engineers. Engineering Abstracts prepared from the Current Periodical Literature of Engineering and Applied Science, published outside the United Kingdom. New Series, No. 13, October. Edited by W. F. Spear. Pp. 176. (London: Institution of Civil Engineers.)
- República Argentina, Ministerio de Agricultura de la Nación: Obis y Meteorología Nacional. Literatura de Ingeniería en Aplicada. Enero y Febrero de 1920, y el estado del tiempo mundial. Por H. H. Clayton y Guillermo Hoxmark. Pp. 18. (Buenos Aires.)
- Rapport annuel sur l'état de l'Observatoire de Paris pour l'année 1921. Par M. B. Baillaud. Pp. 35. (Paris: Impr. Nationale.)
- Department of Mines: Mines Branch, No. 549: Report on structural Materials along the St. Lawrence River, between Prescott, Ont., and Lachine, Que. By Joseph Keele and L. Heber Cole. Pp. 119+30 plates+3 maps. (Ottawa.)
- Nedbortkastelser i Norge utgitt av det Norske Meteorologiske Institut. Årgang 77, 1921. Pp. xiii+79+47+2 maps. (Kristiania: H. Aschehoug and Co.) 6.00 kr.
- Jahrbuch des Norwegischen Meteorologischen Instituts für 1921. Pp. xi+174. (Kristiania: Grøndahl and Son.)
- Field Museum of Natural History. Publication 210, Zoological Series. Vol. 12, No. 3: Game Birds from North-western Venezuela. By H. Osborn and B. Conner. Pp. 17-48. (Chicago.)
- Annual Conference of the Universities of Great Britain and Ireland, 1922. Abridged Report of Proceedings. Pp. 32. (London: Universities Bureau of the British Empire.) 1s.
- Nedbortkastelser i Norge utgitt av det Norske Meteorologiske Institut. Middelværdier, Maksima og Minima. Pp. xvi+xi+83+12 plates+2 maps. (Kristiania: H. Aschehoug and Co.) 6.00 kr.
- State of Illinois. Department of Registration and Education: Division of the Natural History Survey. Bulletin, Vol. 13, Art. 14: Forest Insects in Illinois. I. The Subfamily Oechthiphilinae (Diptera, Family Acromyzidae). By J. R. Malloch. Pp. 345-362. Bulletin, Vol. 13, Art. 15: The Small Bottom and Shore Fauna of the Middle and Lower Illinois River and its Connecting Lakes, Chillicothe to Grafton; its Valuation; its Sources of Food Supply; and its Relation to the Fishery. By R. E. Richardson. Pp. 363-522. Bulletin, Vol. 13, Art. 16: An Ecological Survey of the Prairie Vegetation of Illinois. By H. C. Sampson. Pp. 523-578+plates 48-77. Bulletin, Vol. 14, Art. 1: The Orchard Birds of an Illinois Summer. By S. A. Forbes and A. O. Gross. Pp. 8+6 plates. Bulletin, Vol. 14, Art. 2: Distribution of the Fresh-water Sponges of North America. By F. Smith. Pp. 9-22. (Urbana, Ill.)
- República Argentina, Ministerio de Agricultura de la Nación: Oficina Meteorologica Nacional. Las Condiciones físicas del Atlántico Sur entre el Río de la Plata y las Islas Orcadas del Sur durante el verano. Por R. C. Mossman. Pp. 26. (Buenos Aires.)
- University of London: University College. Calendar, Session 1922-1923. Pp. lxxviii+410+lxix-clxxxviii. (London: Taylor and Francis.)
- Annuaire de l'Académie Royale des Sciences, des Lettres et des Beaux-Arts de Belgique, 1922, 88<sup>e</sup> année. Pp. 124+209+plates. (Bruxelles: M. Lamertin; M. Hayez.)
- Ministry of Agriculture, Egypt. Cotton Research Board. Second Annual Report, 1921. Pp. xvi+203. (Cairo: Government Publications Office.) 15 P.T.
- Bulletin of the American Museum of Natural History. Vol. 45, III: The Predaceous Enemies of Ants. By J. Bequaert. Pp. 271-310. Vol. 45, IV: Ants in their Diverse Relations to the Plant World. By J. Bequaert. Pp. 333-583. Vol. 45, V: The Anatomy of certain Plants from the Belgian Congo, with Special Reference to Myrmecophilism. By I. W. Bailey. Pp. 585-621. Vol. 45, VI: Notes on a Collection of West African Myrmecophiles. By W. M. Mann. Pp. 623-630. Vol. 45, VII: Keys to the Genera and Subgenera of Ants. By W. M. Wheeler. Pp. 633-710. Vol. 45, VIII: A Synonymic List of the Ants of the Ethiopian Region. By W. M. Wheeler. IX: A Synonymic List of the Ants of the Malacasy Region. By W. M. Wheeler. Pp. 711-1053. (New York.)
- Jamaica. Annual Report of the Department of Agriculture for the Year ended 31st December 1921. Pp. 45. (Kingston, Jamaica.)
- Studies on the Cyclostomatous Bryozoa. By F. Canu and R. S. Bassler. (No. 2443; From the Proceedings of the United States National Museum, Vol. 61, Art. 22.) Pp. 160+28 plates. (Washington: Government Printing Office.)

## Diary of Societies.

MONDAY, NOVEMBER 13.

ROYAL SOCIETY OF ARTS, at 8.—J. Slater: The Strand and the Adelphi in Ancient Times.

ENTOMOLOGICAL SOCIETY OF LONDON, at 8.

SURVEYORS' INSTITUTION, at 8.—J. M. Clark: Presidential Opening Address.

ROYAL GEOGRAPHICAL SOCIETY (at Eolian Hall), at 8.30.—Commander F. Will: The Work of "The Quest."

TUESDAY, NOVEMBER 14.

ROYAL HORTICULTURAL SOCIETY, at 3.—Dr. H. Wager: The Colours of Flowers and Fruit. (Master Gardeners' Lecture.)

INSTITUTION OF PETROLEUM TECHNOLOGISTS (at Royal Society of Arts), at 5.

INSTITUTE OF MARINE ENGINEERS, INC., at 6.30.—J. Steinheil: The Evolution of the Nobel Diesel Engine (Part I).

QUETZETT MICROSCOPICAL CLUB, at 7.30.—Dr. R. J. Ludford: The Cytology of Growth.

ILLUMINATING ENGINEERING SOCIETY (at Royal Society of Arts), at 8.—Reports on Progress during the Vacation and Developments in Lamps and Lighting Appliances.

ROYAL PHOTOGRAPHIC SOCIETY OF GREAT BRITAIN, at 7.—J. C. Kingdon: Experiments on the Tensile Strength of Gelatine and Gelatine-jelly: Discussion of the Results as bearing on the Structure of Gelatine: with a Note on the Evolution of Heat by Gelatine when expanding in Water.—K. C. D. Hickman: Rapid Sulphiding of Bromide Prints. Toning with Gases instead of Liquids; together with a Demonstration of the Methods employed.—D. Northall-Laird: Photomicrographs in Colour mounted to exhibit changing Tints.

WEDNESDAY, NOVEMBER 15.

ROYAL MICROSCOPICAL SOCIETY, at 8.—C. Beck: Glare and Flooding in Microscopy. Illustration.—Dr. C. Singer: The First Mechanical Microtome.—Prof. G. S. Thapar: The Occurrence and Significance of a Third Contractile Vacuole in *Paramecium caudatum*.—Prof. B. L. Bhatia: The Significance of Extra Contractile Vacuoles in *Paramecium caudatum*.

ROYAL SOCIETY OF ARTS, at 8.—Dr. S. Smith: The Action of the Beater in Paper Making, with Special Reference to the Theory of the Fibre Board and its Application to Old and New Problems of Beater Design.

THURSDAY, NOVEMBER 16.

ROYAL SOCIETY, at 8.30.—*Probable Papers*.—Prof. A. S. Eddington: The Propagation of Gravitational Waves.—Dr. J. H. Jeans: The Theory of the Scattering of a and  $\beta$  Rays.—Prof. A. P. Chatterjee and L. F. Bates: The Richardson Gyro-magnetic Effect.—P. M. S. Blackett: The Analysis of a Ray Photographs.—J. H. Jones: The Kinetic Energy of Electrons emitted from a hot Tungsten Filament.—Dr. W. Wilson: The Quantum Theory and Electric magnetic phenomena.—S. Marsh and A. E. Evans: Measurements of Electrode Potential-Drop with Direct Current and Alternating Current Electrolysis.

LINNEAN SOCIETY, at 5.

ROYAL AERONAUTICAL SOCIETY (at Royal Society of Arts), at 5.30.—R. McKinnon Wood: The Co-relation of Model and Full-scale Work.

CHILD-STUDY SOCIETY (at Royal Sanitary Institute), at 6.—A. D'Arcy Chapman: The Measurement of the Intelligence of School Children in Massachusetts, U.S.A.

INSTITUTION OF ELECTRICAL ENGINEERS, at 6.—The late Dr. G. Kapp: The Improvement of Power Factor (read by Prof. M. Walker).

CHEMICAL SOCIETY, at 8 (an Informal Meeting).

CAMERA CLUB, at 8.15.—I. H. B. Scott: Lourdes.

FRIDAY, NOVEMBER 17.

ROYAL SOCIETY OF ARTS (Indian Section), at 4.30.—J. W. Meares: The Development of Water Power in India.

INSTITUTION OF MECHANICAL ENGINEERS, at 6.—Adjourned discussion on paper by Sir Vincent L. Raven: Electric Locomotives.

JUNIOR INSTITUTION OF ENGINEERS, at 7.30.—Annual General Meeting.

ROYAL PHOTOGRAPHIC SOCIETY OF GREAT BRITAIN, at 8.—N. E. Lubosch: Definition and Diffusion of Image.

PUBLIC LECTURES.

SATURDAY, NOVEMBER 11.

HORNIMAN MUSEUM (Forest Hill), at 3.30.—Dr. W. A. Cunningham: The Natural History of Crabs.

MONDAY, NOVEMBER 13.

CITY OF LONDON Y.M.C.A. (185 Aldersgate Street), at 6.—Sir Bruce Bruce-Porter: How to Keep Well.

TUESDAY, NOVEMBER 14.

SCHOOL OF ORIENTAL STUDIES, at 5.—Dr. T. G. Bailey: The Sansis, or Thieves of India: their Language, History, and Customs.

ROYAL SANITARY INSTITUTE, at 5.15.—Miss A. D. Muncester: Some Hygienic Aspects of Food and Food Preparation. (1) The Hygiene of Raw Food (Chadwick Lecture).

GRESHAM COLLEGE, at 6.—W. H. Wagstaff: Geometry. Succeeding Lectures on November 15, 16, and 17.

THURSDAY, NOVEMBER 16.

UNIVERSITY COLLEGE, at 2.30.—Miss Margaret A. Murray: Recent Excavations in Malta.

KING'S COLLEGE, at 5.30.—M. Beza: The Story of Cupid and Psyche in Rumanian Folklore.

FRIDAY, NOVEMBER 17.

REDFOOT COLLEGE FOR WOMEN, at 5.30.—Miss K. M. Westaway: Plutarch: His Life and Writings.

SATURDAY, NOVEMBER 18.

HORNIMAN MUSEUM (Forest Hill), at 3.30.—A. D. Howell Smith: Textiles and their History.

# NATURE

A WEEKLY ILLUSTRATED JOURNAL OF SCIENCE.

*"To the solid ground  
Of Nature trusts the mind which builds for aye."*—WORDSWORTH.

No. 2768, VOL. 110]

SATURDAY, NOVEMBER 18, 1922

[PRICE ONE SHILLING

Registered as a Newspaper at the General Post Office.]

[All Rights Reserved.]

## NEWTON'S LANTERNS

SEE FIRST PAGE  
OF SUPPLEMENT.

## REYNOLDS & BRANSON, LTD.

Chemical and Physical Apparatus Makers to His Majesty's  
Government (Home and Overseas Dominions),  
Laboratory Outfitters, &c.

Gold Medals at Allahabad and London. Grand Prix and Gold Medal  
at the International Exhibition, Turin.

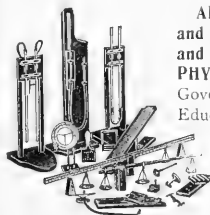

APPARATUS for MACKENZIE  
and FORSTER'S THEORETICAL  
and PRACTICAL MECHANICS and  
PHYSICS as adopted by H.M.  
Government and many important  
Educational Authorities. Price Lists  
on application.

VIDE:—"Theoretical and  
Practical Mechanics and Phy-  
sics," by A. H. MACKENZIE,  
M.A., B.Sc., and A. FORSTER,  
B.Sc.

CATALOGUES POST FREE.

Optical Lanterns and Lantern Slides; Chemical and Physical Apparatus  
and Chemicals; British Made Laboratory Ware (Glass, Porcelain, Nickel  
Ware, and Filter Papers); Chemicals of Guaranteed Purity, including  
"A.R." Quality.

14 COMMERCIAL STREET, LEEDS.

BAIRD & TATLOCK (LONDON) LTD.

SCIENTIFIC INSTRUMENT MANUFACTURERS  
and LABORATORY FURNISHERS.

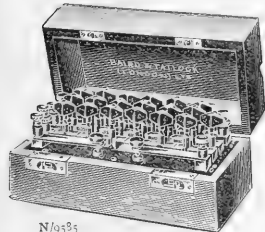

N/9585  
RESISTANCE BOX

Physical  
Apparatus  
for  
Schools  
and  
Colleges.

14-15 CROSS STREET, HATTON GARDEN LONDON, E.C.1.



## HAIR HYGROMETERS

for reading the percentage  
of moisture. Write for de-  
tails of our latest patterns.  
For Laboratories, Cold  
Stores, Drying Chambers,  
etc.

NEGRETTI & ZAMBRA  
38, HOLBORN VIADUCT, E.C.1.  
LONDON.

## CHRISTMAS SCIENCE COURSE IN SWITZERLAND.

DR. RUDOLF STEINER (Editor of standard editions of Goethe's scientific works), whose lectures at the recent Conference at Oxford opened up new fields of work in Education, will give a course of lectures on

### "THE GENESIS AND SUBSEQUENT DEVELOPMENT OF NATURAL SCIENCE IN THE HISTORY OF THE WORLD"

AT THE

GOETHEANUM, DORNACH, near BASLE,

December 24 to January 6.

For all particulars apply SECRETARY, Goetheanum Science Course, 46 Gloucester Place, London, W.1.

## TO SCIENTISTS, RESEARCH STUDENTS, AND SCHOLARS.

### THE INTERNATIONAL BIBLIOGRAPHICAL SERVICE BUREAU

supplies complete Continental and American bibliographies on any scientific, literary, or medical subject. Chemical work a speciality. Extracts made.

Headquarters: Vienna. English representative: "ALEXANDRIAN," 1A Longridge Road, Earl's Court, S.W.5.

## UNION OF SOUTH AFRICA.

### UNIVERSITY OF THE WITWATERSRAND.

Vacancies for:

#### (A) PROFESSOR OF PHILOSOPHY.

*Salary.*—£860 per annum on scale £860-90-1100.

*Passage.*—Allowance of £60 towards passage expenses.

#### (B) LECTURER IN PSYCHOLOGY.

*Salary.*—£464 per annum on scale £464-56-668.

*Passage.*—Allowance of £40 towards passage expenses.

In addition, in both cases a free first-class ticket is provided from Cape Town to Johannesburg, and half-salary is paid during the voyage. Duties commence on March 1, 1923.

Applications, together with copies of testimonials as to qualifications, experience, and character, all in duplicate, must be lodged with the SECRETARY, Office of the High Commissioner for the Union of South Africa, Trafalgar Square, W.C., from whom Forms of Application and further particulars may be obtained, not later than November 22, 1922.

## CIVILIAN EDUCATION STAFF ROYAL AIR FORCE.

Applications are invited for the following vacancies to be filled in January 1923 or earlier:

Electrical and Wireless School, Flowerdown, near Winchester.

MASTER-IN-CHARGE, Grade II.—£600 by £20 to £700.

No. 1 School of Technical Training (Boys), Halton, near Wendover, Bucks.

Several GRADUATE ASSISTANT MASTERS, Grade III.—£275 by £15 to £395, by £20 to £550.

In the case of appointments to Grade III. an allowance up to ten increments of the scale can be granted in respect of previous experience and war service. Preference will be given to candidates who have served as commissioned officers in any of the three Services.

The subjects of instruction include English, Practical Mathematics, Applied Mechanics, Elementary Thermodynamics, Electricity and Drawing. Further particulars and the necessary form of application can be obtained from the SECRETARY (A.E.), Air Ministry, Kingsway, London, W.C.2.

## SWANSEA EDUCATION COMMITTEE. SWANSEA MUNICIPAL SECONDARY SCHOOL FOR GIRLS.

HEADMISTRESS—MISS E. F. PHIPPS, B.A.

WANTED, in January, an ASSISTANT SCIENCE MISTRESS.

Candidates must be Graduates of a British University with qualifications in Physics.

Salary according to the Burnham Scale for Secondary Teachers.

Forms of application may be obtained from the undersigned.

T. J. REES, Director of Education.

Education Offices  
Dynevor Place, Swansea.  
November 1922.

## INDIAN AGRICULTURAL SERVICE.

The Secretary of State for India invites applications for the following posts:

MYCOLOGIST.

DEPUTY DIRECTOR OF AGRICULTURE, WITH SPECIAL INTEREST OR TRAINING IN STOCK-BREEDING. } For service in Burma.

ECONOMIC BOTANIST

For service in the United Provinces.

For the appointments in Burma Indians will not be eligible. In filling the appointments weight will be attached to the possession of University Degrees or Agricultural Diplomas and practical experience; but practical experience alone is insufficient.

Candidates must be between 23 and 30 years of age. The ordinary scale of pay is Rs.350 a month rising to Rs.1250 a month, with Overseas pay varying from Rs.150 to Rs.250 a month for officers of non-Indian domicile, a local allowance varying from Rs.50 to Rs.165 for the officers appointed to Burma, and special initial rates of pay for persons who have served during the war in His Majesty's Forces. There are many selection posts in the Indian Agricultural Service on higher rates of pay.

Full particulars and forms of application may be obtained from the SECRETARY, Commerce and Revenue Department, India Office, London, S.W.1, to whom all applications must be sent not later than December 31.

## UNIVERSITY OF MANCHESTER.

### DEPARTMENT OF BACTERIOLOGY AND PREVENTIVE MEDICINE.

The following appointments will shortly be made in the above department:

ASSISTANT LECTURER IN BACTERIOLOGY.

Stipend, £500 per annum.

DEMONSTRATOR IN BACTERIOLOGY.

Stipend, £400 per annum.

In both cases the applicant appointed must join the Federated Superannuation System for Universities.

A Medical qualification is not an essential condition of either appointment. Applications, together with three testimonials, should be sent to the Internal Registrar on or before November 25, from whom further particulars may be obtained.

## UNIVERSITY OF HONG-KONG.

A LECTURER in MECHANICAL ENGINEERING is required for the University of Hong-Kong. Candidates should be graduates in Engineering of some British University. Preference will be given to unmarried men. A sound knowledge of workshop practice, ability to take students in steam and oil engine work and to lecture on practical subjects, is required. The Lecturer will be expected to keep all the plant of the Laboratories in running order. The appointment will be on a five years' agreement. Salary £500 per annum, converted for purposes of local payment at two shillings to the dollar. Free quarters or an allowance of £100. Half salary from date of embarkation.

Application should be submitted in covers marked "C.A." to the SECRETARY, Board of Education, Whitehall, London, S.W.1. Scottish candidates should apply to the SECRETARY, Scottish Education Department, London, S.W.1.

## ISLE OF WIGHT COUNTY EDUCATION COMMITTEE. SANDOWN COUNTY SECONDARY SCHOOL.

An ASSISTANT MASTER will be wanted after the Christmas holidays to teach Geography as a main subject. Applicants should be Graduates, preferably in Honours, and should state what subsidiary subjects they can offer. Willingness to take part in out-of-school activities will be a strong recommendation. Salary will be paid according to the provisions of the Burnham Secondary Scale. Further particulars and forms of application may be obtained upon receipt of a stamped addressed envelope from the undersigned.

H. JERVIS, M.A., Director of Education.  
County Hall, Newport, I.W.

## UNIVERSITY OF LONDON, KING'S COLLEGE.

The Delegacy require the services of an ASSISTANT LECTURER in PHYSICS; salary £300 per annum. The duties will commence in January 1923. Opportunities will be given for research work.

Applications, with two copies of not more than three recent testimonials, should be received not later than November 30, by the SECRETARY, King's College, Strand, W.C.2, from whom further particulars may be obtained.

## THE MANCHESTER MUSEUM.

The Council of the Manchester University invite applications for the post of KEEPER of the MUSEUM. Preference will be given to candidates who are University graduates in Natural History subjects. Applications must be sent in not later than Saturday, December 2. Information as to the duties and stipend of the post will be supplied in response to enquiries addressed to the SECRETARY of the Manchester Museum.

For other Official Advertisements see p. vi of Supplement.





SATURDAY, NOVEMBER 11, 1922.

## CONTENTS.

	PAGE
Technical Institutions and the Board of Education . . . . .	657
Internal Secretion. By Sir W. M. Bayliss, F.R.S. . . . .	658
The Origin of Worlds. By Dr. A. C. D. Crommelin . . . . .	660
Reservoir and other Dams. By Dr. Brysson Cunningham . . . . .	661
ham . . . . .	662
Science and Progress . . . . .	662
Our Bookshelf . . . . .	662
Letters to the Editor:—	
The Isotopes of Selenium and some other Elements. —Dr. F. W. Aston, F.R.S. . . . .	664
Bohr's Model of the Hydrogen Molecules and their Magnetic Susceptibility.—Prof. Kōtarō Honda . . . . .	664
Gravity Observations in India.—R. D. Oldham, F.R.S. . . . .	665
The Miraculous Draught of Fishes.—T. R. R. S.; Right Hon. Sir Herbert Maxwell, Bart., F.R.S.; Dr. W. B. Drummond; Hy. Harries . . . . .	665
On the Reality of Nerve Energy.—Prof. D. Fraser Harris . . . . .	666
Habits of <i>Echinus esculentus</i> .—Richard Elmhirst . . . . .	667
Perseid Meteors in July 1592.—H. Beveridge . . . . .	667
Skin Effect in Solenoids.—G. Breit . . . . .	668
Colour Vision and Syntony.—H. S. Ryland . . . . .	668
Mosaic Disease in Plants.—Kenneth M. Smith . . . . .	668
Einstein's Paradox.—Rev. H. C. Browne; Prof. H. Wildon Carr . . . . .	668
Waterspouts.—Dr. Willard J. Fisher . . . . .	669
Tables of the Incomplete Gamma-Function.—Prof. Karl Pearson, F.R.S. . . . .	669
The Nitrogen Industry. By Prof. C. H. Desch . . . . .	670
The Thermal Basis of Gas Supply. By Prof. John W. Cobb . . . . .	671
Obituary:—	
Prof. A. Crum Brown, F.R.S. . . . .	673
Prof. J. P. Kuenen. By Prof. H. Kamerlingh Onnes, For. Mem. R.S. . . . .	673
Current Topics and Events . . . . .	674
Our Astronomical Column . . . . .	678
Research Items . . . . .	679
The Origin of Atmospherics. By R. A. Watson Watt . . . . .	680
X-Ray Electrons. By Prof. A. O. Rankine . . . . .	681
Correlation of the Social Sciences . . . . .	682
The Effect of Deformation on the Ar <sub>1</sub> Change in Steels . . . . .	682
Medical Education . . . . .	683
The Chilean Earthquake . . . . .	683
University and Educational Intelligence . . . . .	684
Calendar of Industrial Pioneers . . . . .	685
Societies and Academies . . . . .	685
Official Publications Received . . . . .	688
Diary of Societies . . . . .	688

Editorial and Publishing Offices:

MACMILLAN &amp; CO., LTD.,

57, MARTIN'S STREET, LONDON, W.C.2.

Advertisements and business letters should be addressed to the Publishers.

Editorial communications to the Editor.

Telegraphic Address: PHUSIS, LONDON.

Telephone Number: GERRARD 8830.

NO. 2768, VOL. 110]

## Technical Institutions and the Board of Education.

THE Board of Education has issued a circular (1286) for the purpose of defining full-time teaching service within the meaning of the School Teachers (Superannuation) Act. The Board appears to find much difficulty in defining full-time teaching service—difficulty which would not be shared, we think, by the average layman.

It would seem to us that there are two classes of teachers—those who have chosen teaching as their profession and have taken up full-time appointments under an Education Authority, and those who are known as visiting teachers or part-time teachers, and attend at their educational institutions only in order to conduct the special courses for which they were appointed. Generally speaking, the latter individuals are members of some other profession and would not expect to be regarded as full-time teachers. We can believe that there may be a few border-line cases—but they would be relatively very few, and each case could be considered on its merits. But the Board of Education—or is it the Treasury?—cannot look at the matter in this broad light, and this circular is an attempt to define full-time teaching service. The circular indicates that the first essential for recognition of full-time teaching service should be a formal agreement between employer and teacher in which should be clearly set out the nature of the duties, whether they are wholly of a teaching character, the extent of the employer's claim upon the teacher's working hours, and the restrictions, if any, put upon the employment.

We should have thought that such an agreement would have been sufficient evidence of full-time teaching service, just as it would be sufficient evidence for any judge or jury. Indeed, it is even sufficient for the Board so far as head or assistant teachers on the ordinary staffs of elementary or secondary schools are concerned, but in the case of specialist teachers and of teachers in technical schools and colleges, many of which are of university rank, "it will be necessary to call . . . for information as to the actual teaching hours as evidence of their full-time employment." Teachers in technical schools and colleges have a genuine cause for complaint here—not only because their agreement cannot be regarded by the Board as sufficient evidence in itself, but also because of the nature of the additional evidence to be demanded.

Full-time teaching service consists essentially of two component parts: actual teaching before a class, and the subsidiary duties entailed by actual teaching. The proportional value of these components depends, most

obviously, upon the subject taught, upon the standard which is reached, upon the technicality of the subject, and upon the experimental preparation involved. Therefore it would be impossible for the Board to make any just assessment of the magnitude of the subsidiary duties entailed on a bare return of actual teaching hours. If the Board of Education is unable to accept an approved agreement as sufficient evidence of full-time service, then, in justice to the teachers of science and technology, it must have more information than would be given by a mere return of actual teaching hours.

The circular indicates that the specific preparation of lessons (as distinct from general study) would be regarded as a subsidiary duty entailed by actual teaching, and we would point out here that teachers of science and technology must spend a large amount of time in keeping in touch with modern developments in science, and with the even more rapid and more extensive developments of the applications of science to industry. The time absorbed to this end cannot be regarded fairly as general study of an independent kind; it cannot be considered as dissociated from the teaching service; and it cannot be described as non-essential.

The teacher of science and technology has a claim for very special consideration here, for, though we are prepared to admit that every teacher should and must spend time in general study and should keep in touch with modern developments, yet we cannot be expected to believe that the time which must be spent in keeping up with the development of, for example, Roman history, is comparable with that which must be spent in keeping in touch with the development of electrical engineering.

In this connexion we note with amazement that according to this circular (clause 7) research work will not be regarded as teaching service, and the time spent in research work would not be counted as teaching service for the purpose of the Superannuation Act. We can only hope that either our reading of the clause is wrong or that it has been badly phrased, and does not express the real intention of the Board. If the research work referred to is research work which a teacher is undertaking on behalf of some firm, and for which he is receiving remuneration, then it is quite reasonable to regard such work as private work and not as teaching service to the State. But if the clause means that all research work will be regarded as non-teaching service, then we must protest most emphatically in the interests of the State.

Is it not essential for teachers of science and technology to give a certain amount of attention to research work in order to keep in touch with modern developments? Are there not students doing research work

in many of our technical institutions? Will the time spent by the teachers in these institutions in guiding and directing that work be regarded as of no service to the State? Surely that clause in the circular has been badly phrased: it is incredible that all research work in technical institutions should be banned, by order of the Board of Education! For many years the value of research by teachers has been impressed upon the governing bodies of our chief technical institutions, but if the Board holds that time spent upon such investigations, however stimulating the work may be to teacher or pupil, is to be excluded from the superannuation scheme as pensionable service, then the institutions will be thrown back to the state they were in twenty years ago.

We feel that this circular has been drawn up without sufficient consideration of what is involved in the teaching of scientific and technological subjects, and it would seem that there has not been sufficient regard for the special conditions of teachers of science and technology in our technical schools and colleges.

We are glad to note, however, that the circular has been sent out to local authorities, governing bodies, and others for their observations, and that the Board will not arrive at a final decision as to the application of the principles set out until these observations have been considered. We hope, therefore, to see very considerable amendment in the final form of the circular.

### Internal Secretion.

*Glands in Health and Disease.* By Dr. B. Harrow. Pp. xv+218. (New York: E. P. Dutton and Co., 1922.) n.p.

*Internal Secretion and the Ductless Glands.* By Prof. Swale Vincent. Second edition. Pp. xx+422. (London: E. Arnold and Co., 1922.) 25s. net.

THE two books before us have not the same object or scope, but they appear equally to fulfil the purpose intended. On the whole, they may be said, along with Sir E. Sharpey Schafer's "Endocrine Organs," to be the most useful books on the subject in the English language, apart from the encyclopædic "Endocrinology" edited by Llewellys Barker. While that of Dr. Harrow is of a somewhat popular nature, assuming comparatively little physiological knowledge on the part of the reader, Prof. Swale Vincent's book has the more ambitious aim of a scientific presentation of the facts definitely known on the subject. This latter has therefore rather the character of a work of reference, and will be found very useful in this way. It is naturally not so easy to read as Dr. Harrow's book, which presents an admirable, connected account of the

subject and may be thoroughly recommended to all who wish for a critical statement of the problems which are attracting so much attention at the present time. It is to be hoped that those of us who have been misled by the wild reports of marvellous results published in the Press will adopt Dr. Harrow's cautious attitude and assess such reports at their proper value. Prof. Harvey Cushing, as quoted by Dr. Harrow, remarks :

"Nothing will discredit the subject so effectively as pseudo-scientific reports which find their way into advertising leaflets, where, cleverly intermixed with abstracts from researches of actual value, the administration of pluriglandular compounds is promiscuously advocated for a multitude of symptoms, real and fictitious. The Lewis Carroll of to-day would have Alice nibble from a pituitary mushroom in her left hand and a lutein one in her right hand and presto! She is any height desired!"

The title of Dr. Harrow's book, and also to a lesser degree that of Prof. Vincent's, invites some criticism. The name "gland" implies to the physiologist many organs and tissues which have functions other than that of producing substances for the purpose of exerting a particular action on other organs or tissues when they pass into the blood current. Those which form saliva and also the lymphatic glands may be mentioned. It is true that we might define a gland in a new way and say that any organ that produces some substance not already contained in the blood is entitled to the name. It would conduce to accuracy, however, if the name "gland" were limited to those organs able to pour out a secretion which can be collected and examined—those of "external secretion" in fact. In this case, the ductless "glands" would have to be called "bodies," or some similar name, as is indeed frequently done in speaking of the "pituitary body" or the "supra-renal bodies." The name "secretion" itself as applied to the activity of the endocrine organs is also not very satisfactory.

It must be confessed that we do not possess a really good name for these substances which act as "chemical messengers," formed by special cells for the special purpose, if the expression may be allowed, of producing an effect on another organ or cell when carried to it by the blood. A short word with the meaning of "chemical messenger" is what is wanted. When Prof. Starling and the present reviewer were engaged in investigating the mechanism of pancreatic secretion, we sought in vain for a word of this kind and were finally obliged to be satisfied with "hormone," although we felt that it was not exactly what we wished. It has, however, come into general use, although its meaning as "setting into activity" has caused the introduction of a number of other names, which might perhaps have been avoided. It is to be remembered that a messenger

is sent for a special purpose, although he must take the road or railway which is in existence. Thus one of our hormones in the blood passes by a number of different cells before arriving at that kind which is sensitive to it, just as a letter sent by post is only received at that house to which it is addressed. A definition on the lines suggested would exclude such a constituent of the blood as carbon dioxide, called by Gley a "par-hormone." Carbon dioxide would be produced by all active cells whether the respiratory centre happened to be sensitive to it or not. A train (the blood) carrying soldiers (carbon dioxide) to a port for foreign service (the outer air) might pick up men at various stations (organs of the body) through which it passed. At one station there might be on the platform a nursemaid (the respiratory centre) who greatly admired soldiers. She would be excited by the passage of the train, but it would scarcely be held that the soldiers were sent for that purpose. The development of the special sensibility of the respiratory centre is of course another question.

While each of the books before us is provided with a good index, Dr. Harrow alone gives a list of original works, which, however, does not profess to contain more than the most important ones. Considering that Prof. Vincent's book is especially valuable for reference, it seems unfortunate that he has omitted in this second edition the bibliography contained in the first. It may be putting too great a burden upon him, but it would have been of great service if he had given the titles of papers which seemed to him to contain definite new knowledge, rejecting those numerous ones which have no real value. Perhaps we might ask him to reprint in the next edition the original bibliography, adding to it papers which appeared up to 1915 and referring to *Physiological Abstracts* for the subsequent literature. Although many of the current text-books of physiology serve well for the use of junior students without references, it must not be forgotten that the more advanced of these books are often referred to by research workers and teachers, and information as to the place of more detailed description would greatly increase their value.

The great difficulty of exact research in the problems dealt with is impressed upon readers of either of the books before us. Sensational reports as to the transplantation of organs from one individual to another, or even from one species to a different one, are put in their proper place. It seems certain that individual characters are so highly marked, at all events in the higher mammals, that the only permanent grafting occurs when a tissue is taken from one part of an individual and planted in another part of the same individual. Occasional success has been obtained by L. Loeb between closely related persons, brothers for example.

Otherwise the graft always degenerates sooner or later. All the effect it has is the temporary addition of just that amount of the special hormone present in the cells of the graft when inserted. This appears to be the only basis of the much-talked-of transplantations of Prof. Voronoff.

That part of the subject about which the evidence is most conflicting is the interrelation of the various "ductless glands." Both books deal with this in a duly cautious manner. Prof. Vincent gives a valuable account of the morphology of the different organs and tissues. His views as to the nature of the Islets of Langerhans will perhaps not be generally accepted, but it must be admitted that he brings good evidence.

The only points in Dr. Harrow's book which invite criticism are (1) the undue importance ascribed to adrenaline and to the nervous system in the production of wound shock—we find no reference to the toxicæmic aspect, which would seem to be more appropriate to the subject matter; and (2) the reference to the liver as "the seat of carbohydrate metabolism in the body," in connexion with diabetes. The views of Langfeld are quoted, but the reversibility of the action of the liver enzymes is not taken into consideration. It seems to the reviewer that this word "metabolism" is used far too frequently in a loose way and often when other expressions would convey the meaning much better. The "metabolism" of carbohydrates, for example, should refer to the complete series of chemical changes which take place from the time of their introduction to their final elimination as carbon dioxide and water. When measurements of the oxygen intake are made, what is really done is to determine the whole oxidative processes and should be called "oxidation," not "metabolism" as is common. Similarly, valuable measurements of output of heat have been made. It would be more useful to speak of such determinations as of heat production, not as of metabolism. One also hears sometimes of mere nitrogen estimations in urine as "metabolism experiments." However this may be, it is certainly misleading to suggest that the liver is the most important place of chemical changes in carbohydrates. The whole problem of diabetes is still in a very unsatisfactory state. May it not be that we have given our attention too much to changes in particular compounds, such as glucose or fat, while the fundamental defect is a general failure in oxidative capacity? Thus the pancreatic hormone might be an oxidation-promoter, possibly for glucose, since there is evidence that the combustion of fat and protein is inadequate except in the presence of and as part of a kind of coupled reaction with that of sugar. "Acidosis" rather than "ketosis" should not now be regarded as the cause of diabetic intoxication, as Prof. Vincent suggests.

The multitude of the physiological phenomena concerned, as well as their practical importance, may serve as some excuse for the length of this review. We may conclude with a list of those organs or tissues which appear to Prof. Vincent to have established their claim to be regarded as producing true hormones. These are the thyroid, pancreas, reproductive organs, adrenals, pituitary body, and the intestinal mucous membrane ("secretin"). The evidence as to the parathyroids (which seem to act otherwise), the thymus, kidney, and pineal body is conflicting. It is to be remembered that the chemical nature of two only of the hormones has been discovered. Even active extracts have not been prepared in all cases. Still more uncertainty exists as to the way in which hormones act. There is much yet to be discovered.

W. M. BAYLISS.

### The Origin of Worlds.

*Origine et Formation des Mondes.* Par l'Abbé Th. Moreux. Pp. xii + 401. (Paris: Gaston Doin, 1922.) n.p.

THE Abbé Moreux has essayed, in the volume under notice, the ambitious task of giving a complete explanation of the origin of all the orbs in the solar system. Works on cosmogony have this advantage that no one can positively assert that any particular system is wrong, since certainty is quite unattainable. Hence a reviewer is not called upon to pronounce a theory of cosmogony right or wrong, but merely to note how far it appears to fit in with known facts.

The author uses as his materials nebulae and meteoric swarms; he attributes the dark lanes in the Milky Way and regions where stars are unusually sparse to meteoric clouds, and supposes the outbursts of Novæ afford examples of the collisions between nebulae and meteoric clouds which he assumes to be the origin of systems. He uses the spiral nebula analogy in tracing the distribution of the matter scattered by the collision. At this point he notes the fact that the planetary orbit-planes are arranged alternately on opposite sides of the plane of maximum areas. He also conjectures that the two arms of the spiral were in slightly different planes, and that the planets were developed alternately from one or other of them. This idea seems somewhat fanciful; it is fairly obvious that the two most massive planets, Jupiter and Saturn, would have their orbit planes on opposite sides of that of maximum areas, while the same would probably hold for Uranus and Neptune. Another criticism is that his theory, like that of Laplace, makes Neptune much the oldest planet. It was pointed out by the late Prof. Lowell that

apparently the two outer planets were not much further advanced in development than Jupiter and Saturn, although their much smaller size would imply a shorter career and more rapid development; it therefore seems probable that the order of formation of the giant planets has been from the inside outwards, and not the reverse.

In the matter of the origin of the moon the author does not favour the idea of its separation from the earth by fission, holding that it grew from meteors captured in the outer portion of the extended nebulosity which represented the future earth. Throughout the book he postulates the action of resisting medium; many systems of cosmogony do the same.

A few errata may be noted. On p. 207 the author pours scorn on the suggestion that the comets of Tuttle and De Vico have any connexion with the planets Saturn and Neptune respectively; he overlooks the fact that while the inclinations of their orbits are  $55^\circ$  and  $85^\circ$  respectively, the inclinations of their major axes are much less, so that in each case a shift of the node by a few degrees would bring about intersection with the planetary orbit. In the tables of planetary elements he adopts for Venus the very doubtful rotation period of 68 hours, while he treats both the rotation time and the position of the axis of Uranus as unknown, whereas both are known within narrow limits.

It is of course unreasonable to expect a book on such a subject to settle definitely all the matters on which it treats. Viewing it as a setting forth of the problems presented by our system, with more or less plausible solutions, it makes interesting reading.

A. C. D. CROMMELIN.

### Reservoir and Other Dams.

*The Design and Construction of Dams: including Masonry, Earth, Rock-fill, Timber, and Steel Structures, also the Principal Types of Movable Dams.* By E. Wegmann. Seventh edition, revised and enlarged. Pp. xvii + 555 + plates A-Z + plates AA-VV + plates I-III. (New York: J. Wiley and Sons, Inc.; London: Chapman and Hall, Ltd., 1922.) 50s. net.

MR. WEGMANN'S treatise has been before the public for so long that we imagine its general features will be more or less familiar to all who are engaged in the domain of waterworks engineering. The modest volume of 106 pages which appeared thirty-four years ago has, however, developed considerably in the course of time. It is now a ponderous tome of some 600 quarto pages of text, with well over 100 full-page plates in addition. A volume of such weighty proportions cannot fail to impress the reader

in point of size alone, and it undoubtedly represents a considerable amount of patient toil in its compilation. It is, in fact, not merely a text-book; it is a work of reference, containing diagrams and particulars of most of the notable dams which have been constructed in recent years. It is permissible to the critic to question the wisdom of combining the two objects in a single volume. To the student, a text-book of modest proportions is a desideratum; he needs something easy to handle and conveniently portable, in the pocket if need be. The work of reference, on the other hand, is only required on occasion and may rest in the book-case for long intervals. This combination of text-book with an exhaustive, or nearly exhaustive, record of existing examples is open to the objection that it meets the convenience neither of the student nor of the expert. However, we do not wish unduly to press the point.

In the seventh edition Mr. Wegmann has made his treatise replete with information of a highly valuable character. He has included a full description of the Kensico dam, New York; particulars of the movable dams of the New York State Barge Canal; and a brief notice of the Camarasa dam in Spain. This last is stated to be the highest gravity dam in the world, but surely the Arrowrock dam is higher by 20 ft. Probably what is meant is that the depth of water against the Camarasa dam is not equalled elsewhere. Why is the Arrowrock dam not included in the table of high masonry dams? Another very high dam omitted is the Hetch-Hetchy dam. There is, perhaps, some excuse for this omission, as the dam is yet under construction. Still, its dimensions are known and it is an important undertaking. A new chapter on crest gates and siphon spillways has been added, with particulars of examples built both in America and elsewhere, some of them of considerable size.

The subject of dams, of course, is wider than the sphere of waterworks engineering, although this is, perhaps, the most important field of its application. Mr. Wegmann's treatise covers dams as adapted to river engineering operations, and cofferdams as used in foundation work. Briefly, the volume consists of four parts, the first of which deals with the design and construction of masonry dams; the second, with earthen, rock-fill, timber, and steel dams; the third, with movable dams, cofferdams, and overflow weirs; and the fourth with recent dams of all classes. There is an appendix containing the specifications for the New Croton dam with various supplementary notes, a lengthy bibliography which, unfortunately, is not alphabetically arranged (the writer traced some works with difficulty, and failed to find mention of Mr. Powell Davis's book on irrigation works, which contains a

good deal of information on dams), and a fairly full index.

Taken as a whole, the work undoubtedly maintains its high reputation as a standard authority on the subject of reservoir dam construction, and its wealth of diagrammatic profiles from existing examples will cause it to be of great value to the practising engineer, as well as to the student who is seeking to acquire a knowledge of first principles.

BRYSSON CUNNINGHAM.

### Science and Progress.

*Progress and Science: Essays in Criticism.* By Robert Shafer. Pp. xii+243. (New Haven: Yale University Press; London: Oxford University Press, 1922.) 12s. net.

THIS volume is almost entirely critical, mainly of the doctrine that science has contributed to a more rapid "progress" of the human race as a whole, and that we may expect this progress to continue. Much of the criticism is acute and many other writers are cited—Prof. Bury, Mr. G. D. H. Cole, Mr. Tawney, and Miss Follett; but the main attack falls upon Mr. F. S. Marvin, whose books, "The Living Past" and "The Century of Hope," are largely quoted in the initial chapter, which gives its title to the whole; he is dismissed in the concluding sentence thus: "It follows that men such as Mr. Marvin are hardly doing us any good, are promoting rather beliefs and hopes which may in the end work an intolerable mischief in the world."

It is a challenge to optimism, or rather to meliorism, based on science, and would have more justification if the author could find any passage either in Mr. Marvin's writings, or in any sympathiser's, indicating a belief either that this progress was complete, or that it could be expected to continue without the strenuous efforts of mankind to carry it further and remedy its defects. This Mr. Shafer does not attempt to do. We are, therefore, reduced to asking him one or two quite simple and direct questions as to his judgment of facts.

1. Is it not a fact that the advance of science in the last three or four centuries has, on the whole, led to an enormous alleviation of human suffering and an increase in the capacity and the facilities for happiness?

2. Has not this advance been accompanied by a growth in the collective consciousness of mankind, quite unparalleled in history? And is not this growth in the sense of "humanity" due, partly to the knitting up of the world by the mechanical application of science, partly to the fact that science is in itself a

social thing and that its growth involves the cooperation of multitudes of minds bent on the whole—poison gas and weapons of war notwithstanding—towards increasing human welfare?

3. If this is so, is it an evil or mischievous thing to try to realise these forces in the world and to feel that they are with us in our individual efforts to promote the same great ends?

It should be noticed that Mr. Shafer in his criticism of Mr. Marvin quotes exclusively from the two books mentioned above, which are rather popular summaries of great epochs of history, and does not refer to the more philosophic treatment of the same topics in the various volumes of the "Unity" series published by the Oxford University Press.

### Our Bookshelf.

*The Union of South Africa. Department of Mines and Industries. The Geology of the Country around Heidelberg; Geological Map of the Country around Heidelberg.* By Dr. A. W. Rogers. Pp. 84. (Pretoria: The Government Printing and Stationery Office.) 8s. 6d. net, including map.

THE publication of the official description of the geology of the Heidelberg district has been anticipated with much interest by South African geologists. The main features of the area have long been known on account of the economic importance of the Nigel Reef. Mainly owing to the pioneer work of Dr. Hatch, it was recognised more than twenty years ago that the Heidelberg district forms the south-eastern limb of the great pitching syncline, on the northern limb of which lies the Rand, and it may at once be said that the result of the detailed survey fully confirms the accuracy of Dr. Hatch's general conclusions. The gradual extension of mining towards the East Rand and the sinking of many bore-holes, some of great depth, have clearly shown that the Nigel Reef belongs to the Main Reef series of the Witwatersrand; it is also shown that the whole Witwatersrand system decreases regularly in thickness towards the south and east, from about 25,000 feet near Johannesburg to 15,000 feet at Heidelberg. This is quite in consonance with the theory of its formation as the delta of rivers coming from an old land to the north-west.

In this memoir the structure of the district is lucidly described. The most remarkable feature is the great Sugarbush fault, so called from its relation to the Zuikerboschrand. This is a new discovery of great importance. The fault is apparently nearly vertical, with a down-throw to the south; at one point in its course, where it brings the Ventersdorp Amygdaloid against the Iiospital Hill Series, the throw must be at least 16,000 feet. It therefore ranks as one of the world's greatest dislocations. The fault is certainly of pre-Karoo date, but its relation to the Pretoria Series has not been made out. Probably, however, it was later in date than the deposition of the whole of the Transvaal system, and therefore possibly of early or middle Palaeozoic age.

R. H. RASTALL.

*Patents for Inventions.* By J. Ewart Walker and R. Bruce Foster. Pp. xiii + 377. (London: Sir I. Pitman and Sons, Ltd., 1922.) 21s. net.

THE authors of this book depart somewhat from the usual manner of treating the subject of patent law. After a brief introductory survey, they first deal with the manner of obtaining a patent, detailing the procedure in the Patent Office and in possible opposition proceedings. Their next concern is the establishment in the courts of the validity of the patent, consideration being given both to the general rules governing the interpretation of patents and to the grounds upon which the patent may be held invalid. Finally, the privileges and responsibilities associated with the possession of a valid patent are discussed, the chapters relating to this covering very fully the rights of the patentee in respect of infringements, royalties, licences, etc., and his liabilities as regards revocation and compulsory licences.

By presenting the subject in this sequence, the principles underlying patent law are linked up in a manner which can easily be followed. As, in addition, the treatment throughout is clear and concise and avoids undue stress upon legal technicalities, the book should commend itself not only to legal practitioners but also to business men, directors of industrial research, and others who are interested in the protection and commercial exploitation of inventions.

An appendix, which extends to a little over half the book, contains as its most valuable features the Patents and Designs Acts in a consolidated form, and a list of the leading cases to which reference has been made in the text. Of lesser value relatively are the reprints of the patents forms, the Patents Rules, and the war legislation, the inclusion of which accounts for the abnormal size of the appendix. These reprints, we think, might very reasonably have been dispensed with as adding unnecessarily to the cost of a very useful book. E. J.

*Technische Träume.* Von Hans Günther (W. de Haas). Pp. 83. (Zurich: Rascher & Cie, 1922.) 50 marks.

THIS illustrated pamphlet issued free to subscribers to the journal *Natur und Technik* contains short accounts of the most important of the proposals which have been made from time to time either to use coal more efficiently in view of its complete exhaustion 1500 years hence, or to substitute for it some other source of power. Of schemes falling within the former category the author thinks Ramsay's plan for converting coal into water-gas *in situ* not likely to prove successful, and attaches more importance to the proposals to generate electric current thermo-electrically or by means of carbon cells. Apart from coal and petroleum, natural power has been derived from sunlight, from the wind, from steam in volcanic regions, from the tides, and from the waves of the sea. Sunlight power plants in tropical regions can, he considers, compete with coal at 10s. a ton, while at Landerello in Tuscany all domestic and power heating is supplied by steam from underground heat. The waves have not proved an economical source of power, but the tides are more promising where the necessary structural work is not

too costly. The estimated costs of the Severn Scheme the author thinks too low.

*Filtration: An Elementary Treatise on Industrial Methods and Equipment for the Filtration of Liquids and Gases for those Concerned with Water Supply, Ventilation, and Public Health; Chemists, Mechanical Engineers, and Others.* By T. Roland Wollaston. (Pitman's Technical Primers.) Pp. x + 102. (London: Sir I. Pitman and Sons, Ltd., 1922.) 2s. 6d. net.

THE very ambitious title of this small volume would naturally lead one to expect more than is contained in the book. The author has wasted a good deal of the space at his disposal by a rambling style and by irrelevant discussions. Thus, on p. 4 no less than thirteen lines are sacrificed to a reference to a paper in connexion with two very simple chemical equations which are to be found in every text-book. Much of the text deals with very elementary matters, which should be assumed to be known by the readers. In consequence, the remaining space is insufficient to render possible a clear description, in sufficient detail, of apparatus for technical filtration.

*The Tutorial Chemistry. Part 2, Metals and Physical Chemistry.* By Dr. G. H. Bailey. Edited by Dr. W. Briggs. 12th impression (4th edition). Pp. viii + 494. (London: University Tutorial Press, Ltd., 1922.) 6s. 6d.

DR. BAILEY'S text-book, in its revised form, will continue to be useful to students. It gives a clear introductory course of physical chemistry and of the chemistry of the metals. A good feature is the inclusion of brief accounts of the so-called "rare metals," many of which are now technically important. Specific heats at low temperatures might have been mentioned, and we also miss any allusion to Werner's theory and the cyanide process for silver extraction. There are some criticisms which might be made. The definitions in connexion with the phase rule (§ 45) are not sufficiently precise. Stas's silver was not so pure as is implied (§ 281); the existence of  $MnO_3$  is doubtful; stannous oxide is olive coloured, not black; and the atomic weight of nitrogen is not a whole number within the limits of experimental error (§ 508).

*Mentally Deficient Children: Their Treatment and Training.* By Dr. G. E. Shuttleworth and Dr. W. A. Potts. Fifth edition. Pp. xviii + 320. (London: H. K. Lewis and Co., Ltd., 1922.) 10s. 6d. net.

THE fact that a fifth edition of this book has been required is sufficient evidence of its value. It gives in a very comprehensive form a quantity of useful information, legal and medical, concerning the mentally defective child. At the beginning of the book there is an interesting account of the early efforts of Séguin and other pioneers in this field. This is followed by chapters on the regulations in England and other countries, the types of mental defect, the treatment available, educational, industrial, and moral training. The appendices supply a list of institutions, both in England and America, where treatment is given, as well as the medical certificate forms under the Mental Deficiency Act, and a list of the Binet-Simon tests. There is also an excellent bibliography.

### Letters to the Editor.

[The Editor does not hold himself responsible for opinions expressed by his correspondents. Neither can he undertake to return, or to correspond with the writers of, rejected manuscripts intended for this or any other part of NATURE. No notice is taken of anonymous communications.]

#### The Isotopes of Selenium and some other Elements.

The first experiments with selenium some time ago were not successful. Very satisfactory mass-spectra have now been obtained by vaporising the element itself in the discharge tube. The interpretation of these is quite simple and definite, so that the results may be stated with every confidence. Selenium consists of six isotopes, giving lines at 74 (f), 76 (e), 77 (e), 78 (b), 80 (a), 82 (d). The line at 74 is extremely faint. The intensities of the lines are in the order indicated by the letters, and agree well enough with the chemical atomic weight 79.2. Measurement of the lines shows no detectable deviation from the whole number rule.

Application of the method to cadmium and tellurium has failed to give the mass lines of these elements. The employment of the more volatile  $\text{TeCl}_3$  was also unsuccessful, but incidentally gave evidence of great value, which practically confirms two facts previously suspected, namely, that chlorine has no isotope of mass 39, and that aluminium is a simple element 27.

During some work requiring very prolonged exposures with a gas containing xenon, two new isotopes of that element were discovered at 124, 126, making nine in all. The extreme faintness of both lines indicates that the proportion of these light isotopes in the element is minute.

It will be noticed that the first of these is isobaric with tin, and that the seleniums 78, 80, 82 are isobars of krypton. All isobars so far discovered, including the radioactive ones, have *even* atomic weights.

F. W. ASTON.

Cavendish Laboratory, Cambridge, November 6.

#### Bohr's Model of the Hydrogen Molecules and their Magnetic Susceptibility.

BOHR'S model of the molecules of hydrogen explains very satisfactorily the light dispersion of hydrogen,<sup>1</sup> and gives the same value for the moment of inertia as that deduced from the specific heat;<sup>2</sup> but it is generally believed that the model does not explain the diamagnetic property of the gas.<sup>3</sup> For, according to P. Langevin's theory,<sup>4</sup> the hydrogen molecules must have paramagnetic susceptibility, while as a matter of fact the gas is diamagnetic, as determined by Dr. T. Soné.<sup>5</sup> But, as this note will show, this conclusion is not correct.

It is well known that, besides three degrees of freedom for translation, hydrogen molecules possess two degrees of rotational freedom. According to Bohr's model, this rotational motion must, from the point of view of symmetry, take place about an axis perpendicular to the magnetic axis of the molecules—that is, an axis perpendicular to the line joining two positive nuclei. This rotational motion is uniform and increases with the rise of temperature. Hence

<sup>1</sup> Debye, *Münchener Akademie* (1915), 1.

<sup>2</sup> Reiche, *Ann. der Phys.*, **58** (1919), 632.

<sup>3</sup> J. Kunz, *Phys. Rev.*, **12** (1918), 59.

<sup>4</sup> P. Langevin, *Ann. de Chem. et de Phys.*, **8** (1905), 70.

<sup>5</sup> Sci. Rep. **8** (1919), 115.

the magnetic effect of each molecule due to the revolving electrons vanishes on account of the rotational motion. In this case, therefore, Langevin's theory of paramagnetism is not applicable. Obviously his theory can be applied only when the gas molecules have no degree of rotational freedom, or when they revolve only about their magnetic axes.

If a strong field acts on a uniformly revolving magnet in its plane of revolution (Fig. 1), the rotation begins to become slightly accelerated in the half-revolution in the direction of the field and retarded in the other half, this causing a diamagnetic effect.<sup>6</sup> In the case of the molecules of hydrogen the moment of inertia about the



FIG. 1.

axis of rotation is, however, very large on account of the positive nuclei being apart from each other; hence, during rotation, these two revolving nuclei behave like a large flywheel, and before the revolution of the molecules is sensibly accelerated it is newly excited by thermal impacts. Hence we may assume that this rotation is not sensibly affected by the action of a strong magnetic field, and therefore, in the mean, remains uniform throughout. The hydrogen gas is then diamagnetic, and its susceptibility can be calculated by Langevin's theory of diamagnetism.<sup>7</sup>

Assuming Bohr's new model of the hydrogen molecules (in which the electrons have elliptic orbits), we have for the major axis of the orbit

$$a = \frac{h^2}{4\pi^2 m e^2} \left( \frac{2}{(1 + \kappa)^2} - 1 \right) (n + n')^2,$$

$$\kappa = \frac{1}{\sqrt{3}}, \quad 1 - \epsilon^2 = \frac{n^2}{(n + n')^2}$$

where  $h$  is Planck's universal constant,  $m$  the mass of the electrons, and  $e$  their charge;  $\epsilon$  is the eccentricity of the orbit,  $n$  and  $n'$  are the azimuth and radial quantum numbers.

In the case of  $n + n' = 1$ , the possible orbit is  $n = 1$ ,  $n' = 0$ , which reduces to a circle, the radius of which is

$$a = 0.507 \times 10^{-8},$$

$$\frac{h^2}{4\pi^2 m e^2} \text{ being } 0.532 \times 10^{-8}.$$

The magnetic susceptibility of the gas per gram-molecule is given by

$$\chi = -\frac{nm}{12} \left( \frac{e}{m} \right)^2 \Sigma a^2,$$

where  $n$  is the total number of electrons and  $\Sigma$  is to be taken for different orbits. Applying this formula to the above case, we have

$$\chi = -0.712 \times 10^{-6}.$$

In the case where  $n + n' = 2$ ,  $n = n' = 1$  corresponds to the elliptic orbit. Here  $\epsilon^2 = 3/4$ , and the equivalent radius of the circle is

$$a = 1.433 \times 10^{-8} \text{ cm.},$$

$$\chi = -5.70 \times 10^{-6}.$$

The diamagnetic susceptibility  $\chi = 3.96 \times 10^{-6}$  observed by Dr. T. Soné lies between these two. In actual cases a certain fraction of the whole number of molecules may have the first orbit ( $n = 1$ ,  $n' = 0$ ), and the other fraction the second orbit ( $n = n' = 1$ ), etc. As the orbit becomes greater there is a greater chance that it will collapse into a smaller orbit;

<sup>6</sup> K. Honda and J. Okubo, *Sci. Rep.* **5** (1916), 325.

<sup>7</sup> P. Langevin, *l.c.*



hence the number of molecules with an orbit ( $n, n'$ ) at any instant rapidly decreases with the increase of  $n$  and  $n'$ . If we assume that the hydrogen gas contains only the first and second kinds of molecules, viz., 35 and 65 per cent. respectively, then the calculated value exactly coincides with that observed.

KÔTARÔ HONDA.

Research Institute for Iron, Steel,  
and other Metals,  
Imperial University, Sendai, Japan,  
September 22.

### Gravity Observations in India.

The importance of the bearing of a change in the force of gravity, if such could be established, on all problems connected with the physics of the earth, especially those of the origin of mountains, continents, and oceans, is sufficient justification for directing attention to certain peculiarities in the determinations which have been made at Dehra Dun.

When observations of gravity in India were resumed in 1904, with a group of four identical half-seconds pendulums of v. Sterneck's pattern, the value of gravity at Dehra Dun was determined, by comparison with Potsdam, as 979.063 dynes. The earlier observations of Basevi had given a value equivalent to 978.962 dynes, so there was an apparent increase of 0.101 dyne in the interval between the two sets of observations.

A fuller examination of the evidence has shown that no such conclusion can be drawn from the comparison of these two sets of observations. Basevi's final value at Dehra Dun was derived from an elaborate series of observations, made in a room specially adapted for experimenting on the effect of changes of temperature, and in this the legs of the stand were supported on brick pillars. At the time it was unknown and unsuspected that this would seriously vitiate the results, and we have also on record the value obtained from a preliminary observation, conducted under conditions similar to those in his other stations, where the stand rested directly on a concrete floor at ground-level; this preliminary observation gave a value discordant from the final ones, but differing from the 1904 value by about the same amount as is found in other of his stations which have been re-observed. The position was, therefore, that there was no proof of any change of the force of gravity at Dehra Dun, but equally there was no disproof of such change having taken place; all that could be said was that, if any change had taken place, it must have been of a much smaller order of magnitude than one-tenth of a dyne.

In the course of the new series of observations further evidence came to light. The pendulums, swung regularly every year at the commencement and close of each field season, showed a gradual decrease in the period of vibration till, in November 1909, the mean period had decreased by 0.0000043 seconds, making the apparent value of gravity 979.079 dynes. Since then the time of vibration showed a gradual increase till in April 1913 it had reached a value only 0.0000012 seconds less than in 1904. It has been suggested<sup>1</sup> that the increase after 1909 was due to a gradual wearing of the agate edges; the suggestion is a possible one, but it leaves unexplained the diminution between 1904 and 1909, which was evidently due to some cause which affected all four of the pendulums in about equal degree. There was no change in the routine of observation<sup>2</sup> which could account for it, and the alternatives

seem to be a gradual molecular change in the material of the pendulums, leading to change in length, or a real change in the value of the force of gravity at Dehra Dun. As all four pendulums were made at the same time, of the same material, and, so far as possible, of the same form and dimensions, the former is not impossible, but the latter would equally affect all four simultaneously and alike. The situation therefore remained as in 1904, that, so far as the Indian observations are concerned, there was neither proof nor disproof of any change in the force of gravity having taken place.

In addition to the observations of the Survey of India there have been some other determinations of gravity in India. In 1905 Hecker, at Jalpaiguri, obtained a value which was 0.002 dyne in excess, and in 1906 Alessio, at Colaba, a value of 0.004 dyne in defect, of the Survey of India values, being in substantial agreement with the value determined at Dehra Dun in January-February 1904. In 1913 another determination was made at Dehra Dun, by Prof. Alessio, with an apparatus consisting of eight pendulums prepared for the Filippi expedition to Central Asia, and the value obtained, which has only recently been announced,<sup>3</sup> was 979.079 dynes, or 0.016 dyne in excess of the standard accepted value used by the Survey of India, as determined in 1904. The position therefore now is that, while independent direct comparisons made in the two years following the commencement of the new series of observations in India showed substantial agreement, a similar determination made nine years later showed a material difference, and this opens out the possibility that part, at least, of the changes noticed at Dehra Dun may have been due to a real change in the force of gravity at that place.

The difficulty of accepting such interpretation is less at Dehra Dun than at many other stations, for that place lies on the fringe of the Himalayas, the elevation of which has been one of the latest incidents in the geological history of the earth, and it also lies in a region where the surface deformation, established after the earthquake of April 4, 1905, shows that changes are still taking place.

It is to be hoped that when gravity observations are resumed in India the matter will be looked into; in part the doubt left by these observations might be cleared up by the re-observation of some of the Peninsular stations, where gravity was determined at the outset of the series and about 1909. For example, Colaba (1904), Mysore (1908), and Jubbulpore (1910) seem convenient and suitable; a fresh determination at these stations would show whether there had been a change in the force of gravity as compared with the reference station of Dehra Dun.

R. D. OLDHAM.

### The Miraculous Draught of Fishes.

To the several names of the Sea of Galilee, Prof. Gudger, in his very interesting letter (*NATURE*, October 28, p. 572) has thrice added "Lake of Tiberias," evidently by mistake for "Lake of Tiberias." Also he omits any reference to the important paper by Prof. Théod. Barrois, "Contr. à l'étude de quelques lacs de Syrie" (in *Rev. Biol. du Nord de la France*, tome vi., 1894), which usefully summarises what is known of the fauna of the lake in modern times from Belon in 1553 to his own date in 1894. The lake, it appears, contains twenty-two species of fish, some small fishes and some large ones in vast abundance. As of old, it is subject to sudden squalls, dangerous to navigation. Some of its inflowing waters for their

<sup>1</sup> H. J. Couchman, *Prof. Pap.*, Survey of India, No. 15, p. 2.

<sup>2</sup> Records, Survey of India, vol. 2, 1913, p. 33.

<sup>3</sup> *Rivista Marittima*, March 1922, Supplement, p. 73.

healing properties have, says Prof. Barrois, from the most remote antiquity, attracted patients suffering from eczema, arthritis of every kind, and other afflictions. But, with regard to Prof. Gudger's ingenious explanation of the miraculous draught of fishes, coupled with Lortet's description of the behaviour of grebes over a shoal of large Chromids and Canon Tristram's account of their dorsal fins as seen at the surface, surely the wonder is that experienced fishermen like St. Peter should have needed outside assistance, let alone superhuman aid, as is implied in the narrative of St. John's Gospel.

T. R. R. S.

Tunbridge Wells, October 30.

IN the passage from Lortet's work on the Lake of Tiberias, quoted in Prof. Gudger's interesting letter in NATURE of October 28, p. 572, the scientific title of the crested grebe is given as *Podiceps cristatus*. This misrendering of the true name of the genus *Podiceps* may be traced, I think, to Yarrell, for it appears in his "History of British Birds," published in 1845. Yarrell was not a classical scholar; but it is strange that the late Lord Lilford should have slipped into the same error in his splendid "Coloured Figures of British Birds." The difference in form is important, because *Podiceps*, if it means anything, means "rump-headed"; whereas in coining the word *Podiceps*, meaning "rump-footed," Linnaeus indicated the posterior position of the feet so characteristic of the genus.

HERBERT MAXWELL.

Monreith, Whauphill,  
Wigtownshire.

PROF. E. W. GUDGER'S letter on this subject in NATURE of October 28, p. 573, is interesting from the natural history point of view, but it misses the most suggestive point in the narrative. That point is the number—one hundred and fifty and three. What is the meaning of this very definite figure? It will scarcely be contended that the number is merely the simple statement of a historic fact—that the fishes caught did actually number one hundred and fifty and three, neither more nor less! The naïve literalism of such an explanation is totally blind to the true significance of the story.

Obviously, the story is a parable. The lake of Gennesaret is the world. The fishes are the souls of men. The net that is not broken is the Church. And the number? That is a problem, but an explanation I heard given in a sermon by my father, the late Rev. R. B. Drummond, of Edinburgh, seems to meet the case. Where he found the solution I do not know. It was not original.

The Jews, as is well known, attached a mysterious significance to numbers, and if they met a definite number like this, they would not pass it by unheeding, but would try to discover its meaning. Well now, this number is what is called the perfection of the number 17; that is to say, it is the number arrived at by adding all the consecutive numbers from 1 to 17 inclusive. And the number 17 itself is the sum of the two sacred numbers 7 and 10. These again (here I am a little vague as to why) stand respectively for the Jews and the Gentiles. Hence the story means that the net of the Church is able, without breaking, to gather together not only, as some contended, Jews and those who became Jews, but all sorts and conditions of men of every race and tribe.

W. B. DRUMMOND.

Baldovan Institution, by Dundee.

November 1.

PROF. GUDGER'S communication under this heading in NATURE for October 28, p. 572, has brought back to me a vivid recollection of a fishing incident in the north-west of Ireland. About a dozen years ago I spent a week-end at Ballina, County Mayo, and as the express to Dublin did not leave until after mid-day, I devoted Monday forenoon to a ramble along the banks of the Moy river. Observing several men, with a boat and draw-net, making a succession of fruitless attempts to land fish, I crossed the river and made my way to them. It was true—they had toiled and had caught nothing. They were putting out to make another attempt, and I offered them five shillings for the next haul. They declined. The net was hauled in, and there was not a scrap of anything in it. They put off again, and I repeated my offer, which was rejected, and the net came in empty, as before. With all their futile endeavours the men were not in the least put out. Calmly the boat and net were again got ready, and I was told it would be no use offering to buy the haul. When the net was landed it was found to have brought in one little fish—a sprat in size! Apparently this was looked upon as a good sign—a command to try again, for, still undaunted, the men persevered—they rowed off cheerfully, let out the net, then returned to shore and hauled at the net, but evidently it was harder work than on any previous occasion. When the operation was completed, hundreds—the men said eleven hundred—salmon had been landed! A school from the sea had come up on the rising tide.

HY. HARRIES.

October 28.

#### On the Reality of Nerve Energy.

I HAVE only to-day seen Dr. Adrian's letter of September 30 in which he states with great clearness the present-day physical explanation of the nature and transmission of the nerve impulse.

It seems to me that it is the relation of this nerve impulse to nerve energy that stands in need of elucidation. My present concern is not so much to recommend the more extensive use of the term nerve energy as to make sure that when physiological or medical writers use it, we shall have some more accurate notion of what they mean by it. Evidently, from what Dr. Adrian says, sometimes they mean mental energy. Surely mental energy is not what is meant in the following paragraph, "In defatcation, when all the nerve energy of the cord is directed into one channel . . ." (Verdon, "Angina Pectoris," Brighton, 1920, p. 357). The late Sir William Osler wrote: "An organisation which is defective in what, for want of a better term, we must call nerve force . . ." ("Principles of Medicine," 1895, p. 1032).

Prof. Halliburton, in reviewing von Monakow's "Die Lokalisation im Grosshirn" (*Physiol. Abst.*, Nov. and Dec. 1918), thus expressed himself, "The introduction of a change in the quantity of nervous energy (Hughling's Jackson) passing over a given system of Conduction paths . . ." In his "Text-book of Physiology" (London, Churchill, 1912, p. 1211), Prof. Starling wrote: "During the second stage (of asphyxia) there is a discharge of nerve energy which spreads throughout the whole central nervous system, beginning in the Bulbar Centres . . ." In none of these quotations is it a synonym for mental energy, unless, perhaps, we except Osler's use of it.

(To recognise "mental energy" as a real existence in the sense of being a *vera causa* of neural processes is, I believe, necessary, but it involves grave difficulties both in psychology and metaphysics.)

The authors just quoted are surely not indulging

in metaphors; they evidently have something quite definite before them which they believe is conveyed to their readers. Is it what other writers, e.g. Sir Frederick Mott, would call innervation? Apparently so, for he writes in "The Brain and the Voice in Speech and Song" (*Harper's*, 1910) of "innervation currents." Now currents must be real, must be a flowing of something.

Clinicians—neurologists—believe in nerve energy, but apparently they do not derive their belief from their physiological teachers, for, according to McDougall, "the professional physiologists refer to it (nerve energy) contemptuously as a survival from the Dark Ages." Without doubt, something here is in need of being cleared up.

The intelligent layman thinks there is such a thing as "nerve energy," physicians use the term constantly, some professional physiologists use it when they find it convenient, and yet Dr. Adrian assures us that "as a physiological concept, 'nerve energy' has little to recommend it." If that is so, it is unfortunate the term is so popular. Dr. Adrian, however, concedes that "If the term 'nerve energy' is to be retained, it might be used to mean the total potential energy in the neurone available for use in the transmission of impulses."

This definition is so broad that it would cover (as it should) such cases of innervation as cerebellar control of other nerve centres, as well as unconscious cerebral inhibition of certain lower centres, neither of which could be called mental energy.

This is all that is wanted as a beginning of the clearing of the air. In this sense, nerve energy is real. I had only suggested it might be measured in order, if possible, to satisfy the demand that as a form of energy it should be measured.

It now remains for some physiologist to discuss the reality of nerve energy by defining the concept, relating it to nerve impulses and to innervation-processes, and placing the term in his index. Then the neurologist and psychopathologist would know whether he was using the term nerve energy in the same sense as that in which other men of science use it. In time, something more definite than at present would filter through to the laity.

D. FRASER HARRIS.

Dalhousie University, Halifax, N.S.,  
October 11.

#### Habits of *Echinus esculentus*.

IN the October issue of the Journal of the Marine Biological Association, Miss Trewavas records the occurrence of *Echinus esculentus* between tide-marks on the Cornish coast and makes a request for information "of the occurrence or absence of this sea-urchin between tide-marks at other parts of the British coast."

In this district *E. esculentus* occurs abundantly between tide-marks in spring and early summer, on rocky coasts; a few may be found at almost any other season. About February or early March a shoreward migration seems to set in, so that in suitable weather conditions some hundreds may be collected at springs between April and June. Then their abundance decreases until about November, from when until January it is at a minimum. This inshore vernal maximum is coincident with the spawning season; ripe individuals being found from February to August with a maximum occurring in early May. A similar shoreward spawning migration occurs in other, chiefly Boreal, species—*Solaster papposus*, *S. endeca*, *Henricia sanguinolenta*, *Archidoris tuberculata*, *Jorunna johnstoni*, *Aeolidia papillosa*, *Leander*

*squilla*, *Spirontocaris pusiola*, and doubtless various other species.

The presence of *E. esculentus* between tide-marks is strongly influenced by various conditions—e.g. (1) in April 1921 a spell of sharp frosts caused numerous urchins which had invaded the intertidal zone to retire to deeper water, where they were visible in abundance in 1-2 fms.; (2) during the hot spell of May and June 1921 they were unusually scarce between tide-marks; (3) in April 1922 a spell of heavy weather either washed away or caused a temporary seaward movement of urchins from the intertidal area, and further, although they had also been abundant in 1-2 fms., none were to be seen there, all having apparently retired into the shelter of crevices and boulders. There is some evidence that males approach the shore ahead of the females. While inshore, urchins feed very largely on barnacles.

On an average the life of *E. esculentus*, as an urchin, begins about midsummer; the first months are spent in the Laminarian zone browsing freely on such liny food as Membranipora; by the end of the calendar year some are well over 2 cms. in diameter and at the close of their 1-year period about 4 cms., the more advanced having spawned about May at an approximate age of 10-12 months. The II-year group appear to range between 4-7 cms., the III-year group 7-9 cms., and the IV-year group 9-11 cms. Largely owing to the prolonged spawning period there is no discontinuity between the year groups, which merge into one another. The adults feed on Polyzoa, Laminaria—particularly if encrusted with Membranipora,—balanids, etc. In October urchins are found with large gonads rich in fats; an occasional one may have a few immature ova. The yearly cycle would seem to be:

July—November—Growth and fattening of gonads—Laminarian zone offshore.

December—March—Maturation of gonads—Laminarian zone offshore.

April—June—Spawning—largely inshore.

RICHARD ELMHIRST.

Marine Biological Station,  
Millport.

#### Perseid Meteors in July 1592.

MAY I bring it briefly to the notice of readers of NATURE that there is apparently a reference in the history of Akbar, the Emperor of India, to a brilliant display of Perseid meteors in the Panjab about the end of July 1592. The passage occurs in the account of the 37th year of the reign, and just before the description of Akbar's expedition to Cashmere.

Akbar and his son Daniel had left Lahore and crossed the Rāvi, and were encamped at a garden called the Rāmbāri. On the 27th day of Tir O.S., which might correspond to about July 28, 1592, three hundred little stars or pieces of stars (*siārācha*) were seen traversing the heavens from west to east. The Persian text does not say whether this was in the day or in the night, but presumably it was the night or at least the evening, for the meteors would not be visible during the day.

Akbar and his son were so alarmed at this appearance, which took place three days after their departure from Lahore, and while they were still encamped at Rāmbāri, that they at once consulted the astrologers who were with them in the camp and by their advice broke up their camp and returned to Lahore. Nor did they resume their march till about a fortnight later and after they had ascertained a more auspicious day for a start.

Perhaps the phenomenon was not seen in England or even in Europe. The night may have been foggy, or the transit of the meteors may have taken place in the daytime there.

It does not seem impossible that Shakespeare may have heard of the display from sailors and other travellers in the east when he wrote about the close of the sixteenth century of certain stars shooting madly from their spheres. H. BEVERIDGE.

53 Camden House Road, W.8,  
October 26.

### Skin Effect in Solenoids.

SKIN effect in long, single layer solenoids wound with solid round wire and used at very high frequencies has been treated by Sommerfeld,<sup>1</sup> Lenz,<sup>2</sup> and Abraham, L. Bloch, and E. Bloch.<sup>3</sup> (The frequency is supposed so high that the Rayleigh approximation applies.)

The last of these disagrees with the first, giving the ratio of the resistance of a closely wound solenoid to the resistance of the wire of the solenoid when stretched out straight and used at the same frequency as equal to 3.73, while Abraham, L. Bloch, and E. Bloch obtained 3.46. The writer calculated the same ratio by a different method and obtained  $23.4 \pm 0.02$ . Going through the calculation of Sommerfeld and correcting for an error in the graphical evaluation of the area under Sommerfeld's curve, the same result (3.41) is obtained by Sommerfeld's method. For loosely wound solenoids the calculations of Abraham, L. Bloch, and E. Bloch, Lenz, and the writer are in fair agreement.

On reading this letter Prof. Sommerfeld has informed the writer that he agrees with this conclusion. G. BREIT.

National Research Fellowship,  
Cruft Laboratory,  
Harvard University, U.S.A.

### Colour Vision and Syntony.

AFTER reading the letter of Dr. Edridge Green (NATURE, October 14, p. 513) it occurred to me that the following method, involving no head movement, of observing the movement of positive retinal "after images" might be of interest. If, in a dark room, the eyes being in a state of "dark adaptation" and one covered, a dry petrol lighter of the spring release type be flashed, a fan-shaped pattern of brilliant streamers will be seen. This pattern is followed by a similar "after image." The "after image" immediately begins to contract. This contraction continues till the after image appears as a rather thick irregular line of smaller area and greater brilliancy than the original pattern. The rapidity of the change, and the final form varies for different parts of the retina. Two points are of interest, the contraction of the image, and the increase of brilliancy.

H. S. RYLAND.

London, S.E.,  
Oct. 16.

### Mosaic Disease in Plants.

THERE has been considerable speculation recently upon the cause of the so-called "virus diseases," which occur in both animals and plants, such as typhus and Rocky Mountain fever in man, and

<sup>1</sup> A. Sommerfeld, "Über den Wechselstromwiderstand von Spulen," *Ann. d. Phys.*, 329, p. 169, 1907.

<sup>2</sup> W. Lenz, "Über die Kapazität der Spulen und deren Widerstand und Selbstinduktion bei Wechselstrom," *Ann. d. Phys.*, 342, p. 923, 1912.

<sup>3</sup> H. Abraham, L. Bloch et E. Bloch, "Radio-telegraphie militaire," 1919, E.C.M.R. Report No. 4629.

"mosaic" disease in plants. These diseases are supposed to be due to the presence of some ultra-microscopic filter-passing organism. Many small bodies, some of a granular nature, have been described in connexion with these disorders, such as Rickettsia, Negri bodies, etc. As regards the mosaic disease of plants, L. O. Kunkel, a worker in Hawaii, last year demonstrated the presence of a peculiar body of amoeboid appearance in the diseased cells of maize affected with mosaic.

The purpose of this communication is to place on record the discovery of apparently similar bodies in the tissue of potato plants affected with mosaic, a disease which, so far as the potato is concerned, has become of considerable economic importance. No attempt is made at present to define the nature of this body, but it is hoped that further work may throw more light on the subject. All that can be said is that there is invariably present in the cells of mosaic potato tissue, in close association with the nucleus, an abnormal body which is definitely connected with the disease. Preparations showing these bodies were demonstrated at a recent meeting of the Association of Economic Biologists in London.

KENNETH M. SMITH.

The Victoria University of Manchester.

### Einstein's Paradox.

IN his review of Bergson's new book (NATURE, October 14) Prof. Wildon Carr refers to "Einstein's paradox," which he quotes in inverted commas as follows:—"Suppose a traveller to be enclosed in a cannon-ball and projected from the earth with a velocity amounting to a twenty-thousandth of the velocity of light; suppose him to meet a star and be returned to earth; he will find when he leaves the cannon-ball that if he has been absent two years, the world in his absence has aged two hundred years." It so happens that a paradox of this identical kind was proposed to Einstein himself by M. Painlevé at the Paris conferences in April of this year. Unless I have greatly misunderstood Einstein's reply, as recorded by M. Nordmann in the *Revue des Deux Mondes* of May 1, this particular paradox, arising from the imaginary departure and return of an observer travelling with great speed from a given point and back again, was shown to be one not legitimately derivable from the restricted theory—the theoretical construction is not one to which the transformation formulæ can properly be applied (pp. 146-152).

The humble student of relativity is therefore in the position of a schoolboy who finds that what he learns from one master to-day is contradicted by another to-morrow. Bergson and Nordmann both speak with Einstein's voice; but whereas the former apparently puts the paradox before us categorically as an inescapable Einsteinian fact, the other represents it as a non-Einsteinian fiction. Which of these two views are we to accept? They cannot both be true. Einstein, as quoted by M. Nordmann, advanced good reasons for putting the paradox out of court; but as Bergson was present at some at least of the conferences it appears that these reasons did not seem to him to be convincing.

There is a certain indefiniteness of phrase about the paradox as quoted above which gives rise to doubt. The only observer mentioned is the traveller in the cannon-ball; and it is quite overlooked that he would naturally expect the difference between his time and earth time to be in exactly the opposite direction—he would expect earth time to have advanced by only one-hundredth of his own time.

If the traveller happened to be a relativist, his faith in the transformation formula would receive a rude shock when, instead of the seven and a half days he had calculated, he found on returning that the earth had aged no less than two hundred years.

There is also an obvious slip as regards the speed necessary to produce so large a difference in computed time (assuming the paradox to stand good). An observer travelling out and back with a velocity of one twenty-thousandth the velocity of light, or 9.3 miles per second, would only expect a difference of one-twelfth of a second in either direction between his own time and earth time after two years.<sup>1</sup> This is, perhaps fortunate for us, as the earth travels with twice this velocity, or 18.5 miles per second in its orbital course. The cannon-ball would indeed have to be projected with a velocity of within one twenty-thousandth of the velocity of light, i.e.,  $v=c(1-1/20,000)$  or with the incredible speed of about 185,990 miles per second, to produce the result stated.<sup>2</sup>

This, however, which is plainly only a *lapsus calami*, is of small importance. The difficulty is created, not by the magnitude of the paradox, but by its existence, and the contradiction it opposes to common sense. If true, it throws the whole relativity doctrine into the lap of metaphysics, from which, if we are to believe M. Nordmann, Einstein was determined to rescue it. "La théorie d'Einstein est née de problèmes posés par l'expérience. Elle est née des faits, et son auteur insiste avec beaucoup de vigueur sur ce point. . . Elle est tout le contraire d'un système métaphysique" (p. 134, *loc. cit.*). Obviously this paradox, in any of its forms, can never be subjected to the test of experiment; and as it is a fundamental principle with Einstein that nothing must enter into his theory (and therefore that nothing must interfere with his theory) that cannot be so tested, is not the difficulty thereby automatically ruled out of consideration? These are deep waters, into which a sciolist like myself has to venture carefully, even when it is done of necessity, by way of question, in search of information from competent authority.

H. C. BROWNE.

Dublin, October 26.

THERE is, as Mr. Browne points out, a *lapsus calami* in my quotation. The supposed velocity of the cannon-ball is, not a twenty-thousandth of, but less by about a twenty-thousandth than, the velocity of light. It is an often-quoted paradox, which I heard for the first time from M. Langevin in his address to the Philosophical Congress of Bologna in 1911, and the discussion of it occupies a large part of M. Bergson's book. With regard to the paradox itself, it is, as Mr. Browne very well points out, not a paradox for the relativist but an illustration of the consequence of rejecting the principle of relativity. In exactly the same way Zeno's paradoxes were not paradoxes for Zeno but arguments for his doctrine that nothing moves. The principle of relativity is that it is possible to pass to a completely different frame of reference without breach of continuity, provided that the space-time coefficients vary to maintain the ratio constant. The paradox shows the form which the breach of continuity will assume if with common-sense we suppose the change of the

<sup>1</sup> Taking  $c=1$ , and  $v=1/20,000$ ,

$$t = t' \div \sqrt{1 - 1/400,000,000} = t'(1 + 1/800,000,000 + \text{a negligible}),$$

when  $t' = 2$  years,  $t = 2$  years +  $\frac{63,072,000}{800,000,000}$  seconds, or  $t - t'$  is less than  $1/12$  second.

<sup>2</sup>  $c=1$ ,  $v=1-1/20,000$ .  $1-v^2 = \frac{1}{10,000}$ —a negligible, or  $\sqrt{1-v^2} = \frac{1}{100}$ . Therefore  $t = 100t'$ .

system of reference not to be compensated by a variation in the space-time co-ordinates. There are, in fact, two alternatives. I may conceive my traveller retaining the dimensions of his old system in his new system, then he will become a kind of ephemeral insect or microbe in his new environment, for his proportions will be incommensurate with his old proportions; or, I may conceive him automatically shrinking or expanding in his dimensions proportionately to the change in his environment, then, however much the system changes, he can never become aware of it. This is what I referred to in my article as the relativity of magnitudes. The paradox disappears in the principle of relativity; it arises because common-sense is accustomed to the view that space and time are constant and invariable.

H. WILDON CARR.

November 1.

**Waterspouts.**

CORROBORATING the letter of Dr. G. D. Hale Carpenter in NATURE of September 23, p. 414, reference may be made to a note in *Monthly Weather Review*, 43, p. 550-551, 1915, where a funnel or pendant seen near Cape San Lucas, Lower California, is described and sketched; the sheath or sleeve seen by Dr. Hale Carpenter was very striking. The phenomenon was under observation a considerable time.

Also, the following from my note-book on an observation made in Manila, P.I.:

"1910 V. 24 d. 6 h. 15 m. P.M.—Under a thunderstorm developing in N., from my window I saw a small tornado funnel stretching downward in N.W., obliquely toward W. or S.W. It did not reach halfway to earth; the sun was so low that a flood of yellow light poured horizontally under the cloud, and the funnel was brilliantly lighted. The figure and description given in my note, *Monthly Weather Review*, November 1915, apply excellently, except that the brighter illumination brought out the hollow core better. The distance was greater, so that I could not very well make out the lattice pattern."

This one showed the sleeve or sheath very well. Another, mentioned in the same note in the *Monthly Weather Review*, a gauzy but large waterspout, extending clear to the water, and causing there a great powder-puff of spray, did not show the sleeve at all. (This was near San Salvador, in the Bahamas; the position given by latitude and longitude is quite wrong, inserted by some other hand.)

WILLARD J. FISHER.

Cambridge, Mass., October 16.

**Tables of the Incomplete Gamma-Function.**

I SHOULD be greatly obliged if you could allow me a little of your valuable space to state that Dr. J. F. Tocher has kindly pointed out an error in my Introduction to the above Tables. In a table on page xx the wrong argument has been inserted to the correct value of the function.

An errata slip has now been issued, and will be inserted in all future volumes sold. This slip will be supplied by the Sales Office, H.M. Stationery Office, Princes Street, Westminster, to all past purchasers of the work, and is arranged so that owners of the Tables can paste them over the offending matter.

I can only apologise sincerely to purchasers of the book for this inadvertency. KARL PEARSON.

Department of Applied Statistics, University of London, University College, W.C.I.

## The Nitrogen Industry.

By Prof. C. H. DESCH.

THE discussion on the nitrogen industry, organised by Section B (Chemistry) of the British Association at the Hull meeting, proved to be a great success in spite of certain obvious difficulties in the way of such a discussion at the present time. There are many processes in the field for the fixation of nitrogen, and commercial rivalries make it impossible to secure completely frank and unbiased accounts of the merits of the various systems. Much information of great scientific value has, for commercial reasons, to remain unpublished. The Section was therefore fortunate in obtaining a general survey of the subject from Dr. J. A. Harker, whose experience in this field during and since the war was exceptionally great, his practical acquaintance with most of the competing processes enabling him to take an impartial view of many controversial matters. His paper makes it easier for chemical readers to judge of the value of statements appearing in the technical periodicals and in the popular Press. According to Dr. Harker, there is little to be added in the way of statistical material to the Report of the Nitrogen Products Committee published some eighteen months ago, while the fluctuations in the German exchange make it quite unprofitable to discuss German conditions of production or the possibility of dumping, topics which would otherwise have been attractive to the author of such a paper. The nitrogen question has attracted so much public attention that it has even found its way into school examination papers, although profound ignorance on the subject prevailed five or six years ago, not only among the general public, but also in the circle of high officials directly concerned with questions of national importance.

The oldest process for the synthesis of nitrogen compounds from atmospheric nitrogen is that which employs the electric arc. The great plants in Norway, of immense size and working with the greatest success, are avowedly derived from the laboratory apparatus of the late Lord Rayleigh, and Prof. Birkeland stated that his decision to establish the process as an industrial one was based on the famous presidential address to the British Association by Sir William Crookes. Lord Rayleigh's experiments included the measurement of the relation between the energy consumed and the nitrogen fixed, and it is a striking fact that even now less than two per cent. of the energy of the average arc furnace is absorbed as chemical energy in the initial oxidation of the nitrogen. The modern plants are of enormous size, the two plants at Rjukan, for example, employing a total of 200,000 kilowatts, generated at an astonishingly low cost by means of water power. Several modified arc processes have been tried experimentally, including the Kilburn Scott three-electrode furnace. The use of enriched air has been tried on a large scale by a company having works in Switzerland and Germany, a closed circuit being used, and the nitrogen peroxide removed by cooling instead of absorption. This operation is not free from danger, and serious explosions have taken place. The arc furnace plants erected in France during the war have been closed, the power plants

being required for their original purpose, the electrification of railways.

Of the many processes for the production of synthetic ammonia, the original Haber process, the most familiar of all, has been successfully worked by the Badische Co. at Oppau, and at the even larger works recently completed at Merseburg in Saxony. The pressure in this process is 200 atmospheres, which is not now regarded as high, and the gases move slowly through reaction vessels 40 feet long and 3 feet in external diameter, the walls being 6 inches thick. The gases are pre-heated and circulated. The process worked out at University College, London, by the Nitrogen Products Committee uses higher gas velocities, and was planned to yield about 5 kgm. of ammonia per hour for each litre of space filled with catalyst, instead of 400 gm. as in the Haber system. The first American plant at Sheffield, Alabama, used activated sodamide as the catalyst, but it is not surprising, in view of the action of water vapour on this substance, that it proved a failure; the later modified plant of the Solvay Process Co., now making liquid ammonia for the refrigerating industry, has avoided the defects.

The Claude process uses very high pressures of 900-1000 atmospheres, and the issuing stream contains as much as 25 per cent. of ammonia. Circulation is replaced by multiple stage working, and the reaction vessels, made by a Sheffield steel firm from a special heat-resisting material, are surprisingly small. Hydrogen is to be produced by an improved process from coke oven gas. Electrolytic hydrogen is used on several plants, notably at Terni in Italy, and it seems likely that where water power is cheap, hydrogen can be economically prepared by this means, provided that the form of the cell can be improved.

Cyanamide, regarded by some as obsolete, remains the cheapest form of combined nitrogen, but in spite of this, many of the war works using this process have been closed. The largest plant is that of the American government at Mussel Shoals, the future of which is still uncertain. The German cyanamide plants are being increased in size. A disadvantage of this compound for agricultural purposes is that it is liable to change into dicyandiamide, but attempts are being made to divert it into other more valuable compounds. One American company is converting it into a mixed fertiliser, ammonium phosphate, which is useful but at present too costly. In Switzerland the calcium cyanamide has been converted to free cyanamide by carbonic acid, and then into urea. Mixed with monocalcium phosphate, a product known as phosphazote is obtained, and this substance is used for vines, the cost not being high. Mixed salts containing ammonium nitrate have suffered in popularity through the Oppau explosion, but the use of powerful blasting cartridges, which caused that explosion, is indefensible.

The cyanide process, the oldest of all nitrogen fixation processes, is in use in America for making the acid for plant fumigation, and researches are in progress with the object of cheapening the manufacture.

In concluding his paper, Dr. Harker directed atten-

tion to the large increase in the German capacity to produce synthetic nitrogen compounds, and the erection of new plants in that country. At the end of this year Germany will be independent of all importation of nitrates, while the large munition works in this country are being dismantled. The subject, therefore, has political importance as well as scientific and commercial interest.

Mr. J. H. West's paper dealt with the manufacture of the nitrogen and hydrogen required for synthetic ammonia processes. Three volumes of hydrogen being required for one of nitrogen, and the former being the more expensive gas, the cost of the process depends mainly on that of the hydrogen. The electrolytic process is convenient, and yields pure hydrogen, but the capital cost of the plant is high, and the method is only practicable where cheap hydro-electric power is available. Coke oven gas may be used, the method employed being that of liquefying all the gases present except hydrogen, but in this case the small quantity of carbon monoxide which always remains mixed with it must be removed by chemical washing or by conversion into methane, the gas being a poison to the catalyst in the subsequent ammonia synthesis. Water gas may be used, a reaction with steam being brought about in presence of a catalyst:  $\text{CO} + \text{H}_2\text{O} = \text{CO}_2 + \text{H}_2$ . In a modified process, due to the author and A. Jacques, the coal is treated by a process of complete gasification, and the gaseous products treated in the same apparatus to yield carbon dioxide and hydrogen with a catalyst. Nitrogen is made by the liquid air process, or by mixing air and hydrogen in such proportions that on passing over a suitable catalyst the oxygen is converted to water, and a mixture of nitrogen and hydrogen in the required proportions remains. In the Haber process, water gas and producer gas are mixed in such proportions that a correct mixture is left after removal of the carbon monoxide.

Both this paper, and the succeeding one, by Mr. C. J. Goodwin, were presented in the absence of their authors, so that they suffered in the discussion. Mr. Goodwin described the Häusser process for the production of nitric acid by exploding nitrogen and oxygen with a fuel gas in a bomb. Although the plant has hitherto been on an experimental scale, it is expected that the new bombs of 1200-1500 litres capacity will give commercial yields, and the use of stainless steel has overcome much of the corrosion difficulty. The absorption towers have been greatly reduced in size by employing nickel-chromium steel or silicon-iron for the vessels, under a pressure of 2.5-4 atmospheres. The suggestion has been made that a special

gas engine or Humphrey pump might be used in place of a bomb, in order to utilise the heat energy of the fuel more economically, but it remains to be seen whether such a change would prove advantageous on the whole. The main advantage of the process is its compactness, the size of the plant being small, especially when gases of high calorific value are used.

Dr. E. B. Maxted's contribution concerned the question whether nitrogen fixation, based on water power, could be economically undertaken in this country. Under present conditions, there are several sites in these islands where it should be possible to produce hydro-electric energy for 4*l.*-5*l.* per kilowatt-year, the greater part of this sum representing interest on the capital cost. This would allow of the production of electrolytic hydrogen at a cost of 1*s.* 7*d.* per 1000 cubic feet, which does not compare unfavourably with the cost of hydrogen from fuel. Greater economy would be effected if uses for large supplies of oxygen in the chemical industries could be found. Comparing together the ammonia and cyanamide processes, it appears that a given amount of power, say 10,000 kilowatts, being available, either process would result in the fixation of about the same quantity of nitrogen, but the ammonia process would yield large quantities of oxygen as a by-product, while the cyanamide process would require the bringing of anthracite and lime to the site. There would be some compensating conditions, such as the greater simplicity of the cyanamide process, and the necessity of fixing ammonia by means of an acid.

Mr. E. Kilburn Scott denied the contention that the arc process is uneconomical. It has been stated that in Norway nitric acid could be made profitably where electric energy costs 10*l.* per kilowatt-year, while the Scottish schemes can provide the same quantity for 4*l.* The arc process is the only one capable of utilising off-peak power, and where large generating stations are set up it is quite economical. Moreover, calcium nitrate is the best of all artificial fertilisers. Little else emerged in the discussion. It is clear that processes which promised well during the exceptional conditions of the war have to be re-examined very carefully in regard to their practicability under ordinary conditions of competition, and it has yet to be demonstrated that synthetic processes can be established successfully where power has to be obtained from the combustion of coal. Whatever may prove to be the future of these processes, Dr. Harker's review of the present position of the question will be of value, as an addition to the important memoirs already published from official sources.

### The Thermal Basis of Gas Supply.

By Prof. JOHN W. COBB.

THE amount of attention which has been given in the Press during the past few months to the new basis of charge for gas introduced by the Gas Regulation Act of 1920, is at first sight somewhat surprising and unexpected. To the scientific mind there seems to be so little in it that calls for mental

strain in its comprehension, or for criticism in its introduction.

Gas is now to be sold at so much per therm, and the therm is simply 100,000 British Thermal Units—*i.e.* a convenient multiple of what is the most widely known and generally accepted unit of heat. A

decision having once been taken to charge for gas on a thermal basis, the choice of such a unit was natural if not inevitable. It is true that the justice of making the potential heat units in the gas the sole measure of its usefulness is not to be established completely by *a priori* considerations, although most of us would probably be inclined to look kindly upon the notion from the beginning. There are factors other than potential heat content which might help to determine the value of gas in use, and should, therefore, be considered, such as the temperature attainable on combustion. If these factors were of sufficient importance the assumption that thermal units alone could be rightly taken as determining price would be invalid and a different basis for charging necessary.

Such matters as these were, however, discussed at length in conferences called by Sir George Beilby for the purpose, before the Fuel Research Board made the recommendations to the Board of Trade on which the Act was based. At these conferences the experience and the judgment of gas users and makers were freely drawn upon, and the results of experimental work bearing directly upon the points at issue, made by the Joint Research Committee of the University of Leeds and the Institution of Gas Engineers, were considered. The result was an acceptance by all parties of the principle establishing a thermal basis for the sale of gas. It was accepted that the legislative control of the gas industry, necessary because it is a public service with certain exclusive rights, must be made more elastic in some fundamental respects if the gas industry was to be able to take advantage of technical developments presented to it, and to realise fuel and monetary economies, so obviously desirable at the present time for the public good and its own interests.

The magnitude of that industry and the national importance of improvements effected in it may easily escape notice. The gas industry does not dominate any particular town or locality in the same way that steel dominates Sheffield or Middlesborough, or cotton some of the Lancashire towns, but in estimating the importance of the industry it should be remembered that every city and town and many a village throughout the country has its gasworks, carbonising a total of eighteen million tons of coal per annum, and incidentally employing a capital of some 150 million pounds.

The greater elasticity of control to which reference has been made above included a permission to each company or authority to supply gas of the calorific value which it could produce most economically, although the calorific value being declared a close adherence to the standard was to be secured by systematic outside inspection and testing, in which the recording gas calorimeter was to play a prominent part. On this system one town may be supplying gas of 550 British Thermal Units per cubic foot, and another a 450 gas. Comparison of charges cannot be made fairly on the price per 1000 cu. ft. alone, but requires a correction for calorific value. Charging by the therm, *i.e.* by the potential heat units carried by the gas, simplified the matter by introducing a common denominator.

To Sir George Beilby and others, including the

writer, there seemed to be no difficulty in such a change or objection to it from the consumer's point of view. In justice to the gas industry it may be said that when the matter was under discussion its representatives declared themselves as being apprehensive of the way in which this strange new mode of making out a gas bill would be viewed by some consumers, and, through the ministrations of a certain section of the Press, this apprehension seems to have been justified for the time being.

An explanatory pamphlet bearing "The Therm"<sup>1</sup> as its title has just been issued by the Department of Scientific and Industrial Research (to which the Fuel Research Board is attached) in which the reports of the Fuel Research Board on "Gas Standards" have been reprinted. It is issued at a very low price, presumably with the hope of securing many readers and of placing the public in a less confused state of mind on a question in which a large section has a very direct interest.

There is something to be said for this hope. The only fear is that these reports, although well and clearly written, are somewhat too technical in content and language for the layman. Moreover, although this does not affect the main issue, one disadvantage arises from the fact that although the operative Act is based upon the recommendations of the Fuel Research Board as detailed in the pamphlet, there are some points of difference between the two which might have been indicated.

But it is surely plain enough, answering the question usually asked, that no increase in a gas bill can be rightly attributed to the use of the therm as the basis of charge. If a consumer has burned 2000 cu. ft. of gas with a calorific value of 500 British Thermal Units per cu. ft. he has used 10 therms, and it is a matter of indifference whether he is charged 4s. 2d. per 1000 cu. ft. or 10d. per therm; the same volume and calorific value determine the sum in each case and he pays 100d.

It is true that according to the Act, when a gas-supplying company or authority comes under the new scheme an increase in price may be authorised by the Board of Trade "in order to meet unavoidable increases since the 30th day of June 1914 in the costs and charges of, and incidental to, the production and supply of gas by the undertakers," but that is another matter, and has nothing to do with the use of the therm as the unit of measurement.

Moreover, although it is possible such increase of price may be authorised as essential, in some cases and for the time being, to the stability of a service which must be maintained in the public interest, it is widely recognised inside and outside the gas industry that the full development of public gas supply, with all the undoubted benefits it can confer upon the community, can be attained only through the medium of a cheaper gas. In the opinion of the writer it is also true that, in spite of misleading indications of the moment, the Gas Act of 1920 with its thermal basis of charge is well calculated to stimulate a continuous and general movement in that direction which will become more apparent in the future.

<sup>1</sup> The Therm. Reports of the Fuel Research Board on Gas Standards. (London: Stationery Office, 1922.) 3d. net.



## Obituary.

PROF. A. CRUM BROWN, F.R.S.

ALEXANDER CRUM BROWN was born at Edinburgh on March 26, 1838. His father was Dr. John Brown, minister of Broughton Place United Presbyterian Church; his mother was a sister of Walter Crum, a chemist of distinction. Educated at the Royal High School and at the University of Edinburgh, he graduated as M.A. in 1858 and as M.D. in 1861. In the following year he was awarded the D.Sc. degree of London, and thereafter studied in Germany under Bunsen and Kolbe. Returning to Scotland in 1863, he began his career in Edinburgh as an extra-mural lecturer in chemistry. For six years he taught small classes of medical students and busied himself with research. On the election of Prof. Lyon Playfair in 1869 to represent the University in Parliament, Crum Brown was appointed to succeed him in the chair of chemistry. The department placed under his charge was at first purely medical, but during his tenure it gradually changed its character, and at his retirement in 1908 had become one of the chief departments in the Faculty of Science.

Crum Brown was a man of extraordinary mental activity. The mention of a new subject sent his mind darting and exploring in all directions. In a few moments some pithy saying, some apt suggestion, or perhaps some awkwardly pointed-question would be the outcome, showing his instantaneous grasp of the problem and his insight into its implications. That he was a pioneer far in advance of his contemporaries may be seen in the thesis which he presented at the age of twenty-three for the degree of Doctor of Medicine. It was entitled "On the Theory of Chemical Combination," and displayed such originality of thought as earned it a most discouraging reception, so that the author was deterred from publishing it at the time, and only printed it for circulation among his friends eighteen years later. Even to-day this thesis of 1861 bears a modern aspect, polarity and interatomic forces being at the basis of the presentation, and graphic formulæ being freely used. A pioneering research on the function of the semicircular canals in regard to the sense of balance and rotation, and another (in conjunction with Fraser) on the relationship between physiological activity and chemical constitution, illustrate his fertility of mind. Essentially of a speculative and philosophical turn, he yet invented many practical devices and supervised many practical researches. His name will always be associated with the rule for position isomers in benzene compounds and with the electrolysis of dibasic acids. He became a fellow of the Royal Society in 1879, and was an honorary graduate of all the Scottish Universities. During the years 1892 and 1893 he was president of the Chemical Society.

Apart from his chemistry, Crum Brown was of the widest general culture, and his mastery of languages assumed in Edinburgh circles almost legendary form. His business ability was utilised by his University, his church, and by the Royal Society of Edinburgh, of which he acted as secretary for a quarter of a century. In social gatherings he shone by reason of his wit and his gifts as a raconteur.

Two years after his retirement from University duties, his life was shadowed by the loss of his wife, a daughter of the Rev. James Porter, of Drumlee, Co. Down. Gradually failing bodily health confined him to the house for the past six years, but his mental ability remained unimpaired. His friends could always enjoy the refreshment of a talk with him—a talk sure to abound with quaintly apt stories and interesting reminiscences. After a few weeks' illness he died peacefully on October 28, the last representative of an academic period of singular brilliance.

PROF. J. P. KUENEN.

THE unexpected death of Dr. Johannes Petrus Kuenen on September 25, having taken away from the University of Leyden in the full vigour of life a beloved professor, who only a few days before was invested with the dignity of Rector Magnificus, means a heavy blow to his many friends and in particular to myself. Kuenen returned to Leyden sixteen years ago, and since that time I shared with him the laboratory where he was one of my first pupils. He was born in 1866 and matriculated in 1884 in Leyden, where his father, the celebrated critic of the Old Testament, was then professor. By a life of idealism according to a tradition handed down from father to son he fulfilled the expectations which he then awakened.

As early as 1889 Kuenen became assistant in my laboratory. In 1892 he took his degree on a gold medal prize paper, and in 1893 he lectured as a privat docent. His brilliant experimental researches opened to him a career in Great Britain. After having worked for a time in Ramsay's laboratory, he was appointed professor in Dundee. In a touching letter Sir James Walker tells me how he was struck by the tall and handsome young Dutchman, the first meeting being the beginning of a friendship for life. When we read in Leyden that Kuenen was from the first a success in Dundee, both with his students and his colleagues, that he contrived to do in very adverse circumstances a considerable amount of research work, and that Sir James Walker admired the simple way in which Kuenen overcame experimental difficulties, we see that his friends both at Dundee and Leyden have the same vivid recollection of him. And when Sir James Walker reminds us of Kuenen's genial manner, of his quiet humour in conversation, and of his singing Schubert's songs, it is as if we hear Kuenen here in the laboratory, and with deep mourning we recall the ennobling influence of his presence and the happiness he spread around him everywhere he went by his kind and sunny heart.

Having declined different calls from Holland he accepted that from Leyden in 1906, where he took upon himself the teaching of one of the courses to which Lorentz had consecrated a good deal of his precious powers. Welcomed here with the greatest joy, he immediately exerted a great influence on our scientific life. He earned the profound gratitude of his pupils and general admiration for his love for science, his deep learning and insight, modesty, and unselfishness. To his unlimited helpfulness we have all been

highly indebted, and myself more than any one else. He gave me all that a younger partner can give to the older one. He took an enthusiastic part in the development of the Leyden laboratory, where he was to take over my part of the work. The plans for the extension of the laboratory in which he had all the time worked in a very disadvantageous location, were all made in conjunction with him. It is a great pity that he has been taken away before the beautiful new buildings for his department could be opened. We had both assisted in the preliminary dedication by putting, according to local use, the flag on the roof.

His many-sidedness made him spread widely the benefits of science and of its culture. He wrote, *e.g.*, an extensive and most interesting history of the development of physics in Holland during the last 150 years.

The main part of Kuenen's work lies in thermodynamics. He wrote many papers on it and also lucid and comprehensive books treating the equation of state and the equilibrium of liquid and gaseous phases of mixtures. By his masterly repetition of Galitzine's experiments he much aided science, proving that they could be explained by the influence of small admixtures.

The great achievement of Kuenen was his fundamental work on gaseous mixtures. He was the first to fill out experimentally for a complete series of mixtures of two gaseous substances in different proportions, a surface diagram that can be considered as the analogue of Andrews' line diagram for a single substance. The genius of van der Waals, then depressed by deep mourning, took a new flight when he was asked to work out in connexion with Kuenen's measurements his theory of binary mixtures given before only in sketch. Kuenen discovered then retrograde condensation, and from van der Waals' more extended theory deduced a complete explanation of this process. I

still hold in vivid remembrance how Kuenen, putting in action his magnetic stirrer, the simple but fundamental contrivance by which he succeeded in eliminating retardation, had the satisfaction of demonstrating to van der Waals the retrograde condensation, and of seeing van der Waals looking in deep reflection at the beautiful phenomenon, which at once put his theory beyond any doubt. An admirable interaction of Kuenen's experiments and van der Waals' deductions followed.

Kuenen's discovery of mixtures with minimum critical temperatures and maximum vapour pressures led to many important discussions on the properties of the transversal plait on the free energy surface for the mixtures. A happy extension of his research, partly with Robson, was the study of different pairs of substances, which are not miscible in all proportions in the liquid state. It brought experimental material for the investigation of the longitudinal plait in connexion with the transverse one, where the theory of plaits of Korteweg had to be combined with van der Waals' theory, forming an imposing whole, that showed the way in what seemed once a labyrinth. A posthumous work of Kuenen with Verschoyle and van Urk continuing the work with Prof. Clark on the retrograde condensation of mixtures of oxygen and nitrogen makes the last as well as the first of his papers belong to his great life-work. Kuenen leaves incorporated in science a diversity of images systematising in the light of theory the full life of concrete facts in a wide domain and constituting a lasting monument to his genius.

H. KAMERLINGH ONNES.

DR. ALBERT A. STURLEY, instructor in physics at Yale University, and formerly professor of physics in the University of King's College, Windsor, Nova Scotia, died in New Haven, Connecticut, U.S.A., on October 22, at the age of thirty-five years.

### Current Topics and Events.

H.M. THE KING has approved of the following awards this year by the president and council of the Royal Society: A Royal medal to Mr. C. T. R. Wilson, for his researches on condensation, nuclei and atmospheric electricity; and a Royal medal to Mr. J. Barcroft, for his researches in physiology, and especially for his work in connexion with respiration. The following awards have also been made by the president and council: The Copley medal to Sir Ernest Rutherford, for his researches in radioactivity and atomic structure; the Rumford medal to Prof. Pieter Zeeman, for his researches in optics; the Davy medal to Prof. J. F. Thorpe, for his researches in synthetic organic chemistry; the Darwin medal to Prof. R. C. Punnett, for his researches in the science of genetics; the Buchanan medal to Sir David Bruce, for his researches and discoveries in tropical medicine; the Sylvester medal to Prof. T. Levi-Civita, for his researches in geometry and mechanics; and the Hughes medal to Dr. F. W. Aston, for his discovery of isotopes of a large number of the elements by the method of positive rays.

THE Royal Swedish Academy of Sciences, Stockholm, has awarded the Nobel prizes for physics and chemistry for 1921 and 1922 as follows: Physics, 1921, Prof. Albert Einstein, Berlin, for his theory of relativity and general work in physics; 1922, Prof. Niels Bohr, Copenhagen, for his researches on the structure of atoms and radiation. Chemistry, 1921, Prof. F. Soddy, Oxford, for his contributions to the knowledge of the chemistry of the radioactive elements and the nature of isotopes; 1922, Dr. F. W. Aston, Cambridge, for his investigations of elements and isotopes with the mass-spectrograph. The Nobel prize for medicine is reserved for next year, and that for peace will be announced on December 10, the anniversary of the death of Alfred Nobel, when the prizes will be presented by the King of Sweden.

THE well-known periodical, *Curtis's Botanical Magazine*, which appeared regularly from its foundation in 1787 until the end of 1920, has now fortunately reappeared under new auspices. The first part of Volume 148 has just been published by Messrs. H. F.

and G. Witherby, for the Royal Horticultural Society, the new proprietors of this valuable publication, and the Society has been so fortunate as to secure Dr. O. Stapf, late Keeper of the Herbarium and Library of the Royal Botanic Gardens, Kew, as editor. The long connexion between Kew and the magazine will thus, we hope, be maintained in the future as in the past, and in fact the legend on the cover which states, "Hand-coloured figures with descriptions and observations on the Botany, History, and Culture of new and rare Plants from the Royal Botanic Gardens, Kew, and other Botanical Establishments," gives good assurance that this will be the case. Indeed it is difficult to imagine that a work of this kind, to be of real value, could be prepared without the close connexion with Kew being fully maintained. This part, the 'first' of the new venture, is one on which the new proprietors as well as the editor and publishers deserve to be highly congratulated. The plates are beautifully drawn and are both accurate and artistic, while the colouring leaves very little to be desired. There is the same fidelity to botanical detail with which readers of the older volumes are familiar and which makes the plates of so much value. The drawings in this part are the work of three different artists, and we think it is not undue praise to say that they are worthy of the magazine in its best days. The beauty and fidelity of such plates as those of *Stapelia tsumoensis*, a very difficult subject; *Bulbophyllum triste*, a delicate and very remarkable orchid from India, and *Symphytum grandiflorum*, leave nothing to be desired. An ample description both in Latin and English accompanies each plate, and there is much additional matter of an interesting and very useful nature. The English descriptions might possibly be somewhat abbreviated and also some of the general discussion, but it is all of value and shows how much care and trouble the editor must have spent to produce the letterpress, which is a mine of useful information. A volume for the year 1921 to preserve the continuity of the magazine is being prepared by private enterprise.

THROUGH the courtesy of Admiral of the Fleet Sir Henry B. Jackson, chairman of the Radio Research Board under the Department of Scientific and Industrial Research, we are able to publish this week an article on "The Origin of Atmospherics" by Mr. R. A. Watson Watt, who is in charge of the Board's Research Station at Aldershot. The interesting results described will no doubt receive close attention from the scientific public. The members of the Radio Research Board and of its Sub-Committee on Atmospherics who are responsible for the investigations carried out at the Aldershot Station are as follows: *Radio Research Board*.—Admiral Sir Henry B. Jackson (chairman), Captain C. E. Kennedy-Purvis, Lieut.-Col. A. G. T. Cusins, Wing-Commander J. B. Bowen, Mr. E. H. Shaughnessy, Sir Ernest Rutherford, Sir J. E. Petavel, Prof. G. W. O. Howe, Mr. O. F. Brown, and Mr. L. C. Bromley (secretary). *Sub-Committee B on Atmospherics*.—Colonel H. G. Lyons (chairman), Prof. S. Chapman, Major H. P. T. Lefroy, Mr. A. A. Campbell Swinton, Mr. R. A.

Watson Watt, Mr. G. I. Taylor, Mr. C. T. R. Wilson, Mr. H. Morris Airey, Dr. G. C. Simpson, and Mr. O. F. Brown (secretary).

At a general meeting of the Royal Scottish Geographical Society, held on November 7, the Society's gold medal was awarded to Prof. J. W. Gregory, University of Glasgow, in recognition of the scientific importance of results obtained by him through explorations in Spitsbergen, Australia, East Africa, and South-west China.

THE Thomas Hawksley lecture of the Institution of Mechanical Engineers will be delivered at 6 o'clock on Friday, December 1, by Dr. T. E. Stanton, who will take as his subject, "Some Recent Researches on Lubrication."

MR. R. T. A. INNES, the Union Astronomer at Johannesburg, who is at present in Paris and will be in England in a few weeks' time, has had the degree of doctor of science, *honoris causa*, conferred upon him by the University of Leyden.

THE following new appointments in the Peabody Museum of Natural History have recently been announced by Yale University: to be director, Dr. R. S. Lull, professor of vertebrate palæontology; to be curator of mineralogy, Dr. W. E. Ford, professor of mineralogy, in succession to Prof. E. S. Dana, who has held the curatorship since 1874.

IN connexion with the Liverpool section of the Society of Chemical Industry a Hurter Memorial Lecture will be delivered at 8 o'clock on Wednesday, November 22, in the Chemistry Lecture Theatre of the University, Liverpool, by Mr. W. Macnab. The subject will be "Some Achievements of Chemical Industry during the War, in this Country and in France."

THE council of the Institution of Civil Engineers has made the following awards in respect of papers printed without discussion in the Proceedings for the session 1921-1922: A George Stephenson gold medal to Dr. B. C. Laws (London); Telford premiums to Prof. L. Bairdow (London), Dr. A. J. Sutton Pippard (London), Mr. E. A. Cullen (Brisbane), Mr. H. H. Dare (Roseville, N.S.W.), and Mr. F. W. Stephen (Aberdeen). And for papers read before meetings of students in London and the provinces: A Miller prize and the James Forrest medal to Mr. F. H. Bullock (Cardiff); and Miller prizes to Mr. J. G. Mitchell (London), Mr. A. G. McDonald (London), and Mr. Harry Wolf (Manchester).

THE twenty-fifth annual Traill-Taylor memorial lecture was delivered by Dr. Reginald S. Clay at the house of the Royal Photographic Society on October 10, and is printed in full with numerous illustrations in the November number of the Society's Journal. The subject was "The Photographic Lens from the Historical Point of View," and the discourse is probably the most complete, if not the most extensive treatment of the subject now available. The lecturer referred to "two great inventions"—first, the anastigmats of Schroeder, Rudolf, and von

Hoegh, and second, the Cooke lens of Harold Dennis Taylor, and remarked that only time can show which of these has been of greatest value, and upon which, if either, the objective of the future will be based. He adds, "I do not think the great step which the Cooke lens marks is as well appreciated here as on the Continent . . . the Zeiss Unar and Tessar were based on the same principle as the Cooke lens. . . . Harting has also made several lenses which are modified Cookes."

THE Optical Society of America held its seventh annual meeting and exhibition of optical instruments at the Bureau of Standards, Washington, on October 25-28. Special sessions were arranged for the consideration of radiation, atmospheric optics, physiological optics, photometry, optical pyrometry and photography, and the whole process of manufacturing optical glass was available for inspection during the meeting. Reports of committees which have been considering the combination of the Journal of the Society with the Instrument Makers' Journal and the possibility of publishing a translation of Helmholtz's "Physiologische Optik" were received. Informal accounts of the present position of the work of the committees on nomenclature and standards of polarimetry, reflectometry, spectroradiometry, refractometry, visual sensitometry, optical glass and instruments, wave-lengths, illumination and photometry, photography, pyrometry, and spectrophotometry were also given. Visitors not members of the Optical Society were allowed at both meetings and exhibitions of apparatus.

THE annual report of the Chief Medical Officer of the Ministry of Health for the year 1921, recently issued, is entitled, "On the State of the Public Health." The death-rate for that year was 12.1 per 1000 persons living, the lowest on record; the birth-rate 22.4, a decline of 3.1 on the previous year. The infant mortality was 83 per 1000 births, a very low figure, though slightly higher than that of 1920. Of 1000 deaths from all causes, cancer accounted for 100, bronchitis for 73, pneumonia for 76, heart diseases for 117, and nervous diseases for 105. As regards infective diseases, no cases of plague, cholera, or typhus fever occurred, and influenza remained at a very low ebb during the greater part of the year, but 336 cases of smallpox were recorded. Only 12 new indigenous cases of malaria were detected, as compared with 36 in the previous year and 103 in 1919. Encephalitis lethargica increased, 1470 cases being recorded, as compared with 844 cases in 1920. Tuberculosis is decreasing, the number of cases notified being the lowest recorded. Much information is given on schemes for maternity and child welfare, on the prevention of venereal diseases, on the care and after-care of tuberculous cases, on the relation of food to health and disease, and on the medical and sanitary administration of the country.

IN *Scribner's Magazine* for November, Dr. George E. Hale describes the buildings now being erected in Washington for the National Academy of Sciences and the National Research Council. The architect

is Bertram Grosvenor Goodhue of New York, and the sculptural decoration has been entrusted to Lee Lawrie. The complete plan is a hollow square with a frontage of 260 feet, the centre of which will be occupied by a domed hall surrounded by seven top-lit exhibition rooms. For the present only this central area and the front block are being erected. The two upper floors of the front block will contain the offices of the Academy and the Research Council; the entrance hall on the ground floor will be flanked by a library, lecture-rooms, and conference rooms. The central hall, though primarily intended for exhibits, will be capable of transformation into a lecture-room or meeting-room. The novelty of the scheme lies in the utilisation of the central space for a museum of discovery. Those natural phenomena which for the time being provide the chief fields of investigation, the apparatus for studying them, and the means by which fundamental discoveries in pure science are applied for the public welfare will all be demonstrated in a permanent but ever-changing exhibition, kept constantly up-to-date, and covering the whole range of the physical and biological sciences. At the same time the provision of a convenient and dignified headquarters for the National Academy and the Research Council will greatly assist those two bodies in their tasks of advising the Government and organising the scientific work and resources of the United States. The building will doubtless justify the title of Dr. Hale's article as "A National Focus of Science and Research."

THE annual report of the Lancaster Astronomical and Scientific Association has recently been received. The rules and regulations of the Association are such as could with advantage be imitated and followed by many other similar institutions up and down the country. It is apparently conducted entirely by honorary officials, and the motto borne by the Association is clearly the whole spirit of the work—"If we succeed in giving the love of learning, the learning itself is sure to follow"—Lord Avebury. The Association has a total of 281 members. Lectures are given monthly and they are of a scientific and educational character. Meteorology forms an important feature of the report. Monthly and weekly results from readings taken at the Greg Observatory are sent to the Meteorological Office and are used in the official publications. Mean values for each month throughout the year 1921 are given in the report for barometer as well as the extreme readings, the duration of bright sunshine and the number of sunless days. Monthly rainfall statistics are tabulated, and during 1921 the total measurement was 41.25 in., which fell on 194 days. Lancaster escaped the drought from which so many other places suffered, and the showers during the summer kept the ground from being dried up. The mean air temperature for the year was 50°·2 F., which is warmer than either of the two preceding years.

THE recently issued report of the museums of the Brooklyn Institute (N.Y.) for 1921 shows that the children are well catered for, not only in the delightful

Children's Museum, but also at the Central Museum. Here it is the higher grade schools that receive chief attention, and an attempt is made to correlate the demonstrations with their curriculum. Besides the classes at the Museum, full use was made of the collection of lantern slides, more than 2800 being sent out on loan. The department of ethnology continues to furnish suggestive material to the American clothing and allied industries; four rooms have been constructed and equipped for the increasing number of artists and manufacturers consulting these collections.

ONE way in which the Smithsonian Institution pursues "the increase of knowledge" is by exploration and field-work. A richly-illustrated pamphlet describing the work so accomplished during 1921 has been issued as Publication 2669. The prevailing high costs restricted the number of expeditions, but fourteen of the more important ranged from China to Chile and brought back large collections to the United States National Museum. Our own museums do their share of exploration, but the great advantage possessed by the museum at Washington is that it seems able to detail its own staff for this purpose. This is to the benefit of both the individuals and the eventual study of the collections. Dr. C. D. Walcott continued his exploration of pre-Devonian strata in the Canadian Rockies. Dr. Bassler collected fossils in Tennessee for study and for exhibition. Mr. Gilmore collected fossil vertebrates in New Mexico, and Mr. Gidley did the same in Arizona, California, and Nebraska. Dr. Hitchcock collected and studied grasses and bamboos in the Philippines, Japan, and China. Dr. Bartsch visited the Tortugas and the Bahamas in connexion with his breeding experiments on the mollusc *Cerion*. Dr. Aldrich was sent to Alaska to collect insects. Seven other expeditions were devoted to archaeological field-work in the United States and Dominica, and on them also many members of the staff were engaged. The health and enthusiasm gained by this contact with Nature in the open air must be a great help to the workers during the rest of the year.

THE Geological Survey of South Africa has earned the thanks of a wide circle by publishing, as Memoir No. 18, "A Bibliography of South African Geology to the end of 1920" (Pretoria, 1922, price 10s. 6d.). Mr. A. L. Hall has undertaken what must have been an arduous task, and Miss M. Wilman has generously supplied him with the data collected by her since the publication of her "Catalogue of Printed Books, Papers, etc.," in 1905. The result is a clearly printed list, classified by authors, of 5794 entries, and covering even remarks put forward in the discussions that are so usefully printed in the Proceedings of the Geological Society of South Africa. The only slips that we have noticed are in one or two initials of authors, and here and there the omission of the place of publication or of a date. "Liège," which is used throughout, is of course a repetition of a common error. The whole question of a uniform system of abbreviations has still to be considered. "Jl." for Journal and "Ro."

for Royal are unusual and unnecessary. "G.S., U.S.A." is misleading for a publication that has nothing to do with the senior Union across the Atlantic, and "Minn." means Minnesota and should not be used for Minneapolis. There should be no comma, though this has been systematically inserted, after the first "S" in "G.S.S.A." However, the complete list of serials quoted at the outset helps us over these small difficulties, and Mr. Hall's energy has cleared away a thousand greater ones from the path of the student of South African geology.

WITH the enormous increase in the production of petroleum and the widely different uses to which the commercial products are put, the various international congresses which met prior to the war, realising the importance of standard methods of testing, attempted to deal with the question internationally, but little practical success was achieved. With such products so many of the tests are empirical, depending, like the flash point and so-called viscosity, on the form of apparatus and conditions of testing, that standardisation is absolutely essential if the tests are to have real value. It remained for the greatest producing country, the United States of America, through that valuable body the American Society for Testing Materials, to accomplish successfully the work of standardisation of methods, and defining as accurately as possible the desired characters of the various products. In this country, which although not a producing country is one of the largest consumers and controls many important oil fields, the Institution of Petroleum Technologists decided last year that standardisation must be taken in hand, and at a meeting of the Institution on October 10 Dr. A. E. Dunstan gave a summary of the progress which had been made. Hearty support and assistance was given by all the Government Departments concerned with the use of oil products, and by the British oil companies, and co-operation with the British Engineering Standards Association, a body representing a most important section of users, has been arranged to deal with specifications. The work of standardisation has been divided between the six following sub-committees: naturally occurring bituminous substances (crude oils, etc.); distillates up to kerosene; kerosenes and intermediates; lubricants; liquid fuels; asphaltum and artificial residues. It is anticipated that the methods recommended will be issued early next year.

REFERRING to the article on "The Sense of Smell in Birds" in NATURE of June 17, Dr. B. S. Neuhausen, of Johns Hopkins University, Baltimore, writes to direct attention to a paper by Dr. H. H. Beck on "The Occult Senses in Birds" (*Auk*, 1920, xxxvii, 55). In this communication Dr. Beck gave an example of the great food-finding powers of carrion-eating birds. At a hunt, one frosty morning in Pennsylvania, a dog went mad and had to be shot: the body was thrown into a limestone sinkhole close at hand, where it was speedily located by turkey vultures, the nearest haunt of which was eight miles

away. One may readily agree with the author that a freshly killed dog would give off little odour at a temperature below freezing-point, and one must accept his opinion that the body was practically invisible in the hole; but there seems to be no conclusive evidence that the incident of the killing could not have been both seen and heard by the vultures. Dr. Beck's theory is that none of the ordinary senses suffices to explain events like this, and that some "occult sense," by which he means a sense not within the scope of our own subjective experience, must be invoked. He would have us believe that birds possess a special "homing sense" and a special "food-finding sense," while a "mate-finding sense" is mentioned as a third possibility. It seems more

than doubtful, however, whether naming new senses adds anything to our knowledge of the subject. The idea of a sense has little meaning if divorced from the idea of a sense-mechanism, and a "food-finding sense" implies that food (a comprehensive term in the case of birds) is capable of acting as a direct and simple physiological stimulus through some unknown channel of perception which is independent of such more obvious properties of the food as its appearance and odour. Granted that birds have powers of perception transcending our subjective experience, it is surely more reasonable to attribute these to greater acuteness of the known senses than to imagine new senses for which no physiological basis can be suggested.

### Our Astronomical Column.

**FIREBALL ON OCTOBER 31.**—In daylight on the early evening of Tuesday, October 31, at 5.10, an unusually brilliant meteor was observed from various places in the south of England, including Neath, Hereford, Bournemouth, Goring, Witney, and on the eastern boundary of South Wales. The accounts of its appearance, while they all testify to the startling lustre of the object, are yet imperfect and inexact in describing the course it traversed. There were only a few of the brighter stars visible at the time. On the basis of the available data it is impossible to compute a perfectly satisfactory real path for the meteor, but it appears probable that the radiant point was at  $104^{\circ} + 33'$ , and that during its luminous flight the meteor was over the region from Brecon to Wiltshire, the height declining from 65 to 29 miles. Further observations would be valuable.

**SOLAR PHYSICS OBSERVATORY, CAMBRIDGE.**—The ninth annual report of the Director of the Solar Physics Observatory has recently been issued; in it is described briefly the work done during the year April 1921 to March 1922. The observations of two novæ, Nova Aquitæ III, and Nova Cygni III. (1920), have been under discussion; those of the former are expected to appear in Parts 2 and 3 of vol. 4 of the annals, while the latter have been communicated to the Royal Astronomical Society (Mon. Not. R.A.S. vol. 82, p. 44). The well-known variable  $\beta$  Lyrae has been investigated, and 64 spectrograms taken at Cambridge in 1921 and 96 taken in 1907 at the Allegheny Observatory are being reduced. It is stated that the indications of the results are that the system of  $\beta$  Lyrae contains probably at least four components in relative motion. Three lines of work relate to the investigation of the circulation of the atmosphere of the sun. The first is a detailed discussion of the shapes of the clustered masses of flocculi, recently referred to in this column, showing that these masses are inclined at certain angles to the solar equator. The second is a study of the proper motions of the sunspots and the movements of zones of prominence activity; while the third is the determination of the solar rotation by the spectroscopic method, also recently described. The observations and experiments in the department of meteorological physics have been continued. It is interesting to note that the mounting of the three-foot reflector will be completed since the staging has now been finished.

**THE METEORS OF THE PONS-WINNECKE COMET.**—Mr. G. Shain, of Pulkovo Observatory, discusses this

meteor swarm in *Astr. Nach.*, No. 5190, noting that the agreement of the radiant with that calculated from the cometary orbit indicates a common tangent to the two orbits, but identity is only shown if they are found to have the same secular perturbations. It will be remembered that it was in this manner that Prof. J. C. Adams showed that the period of the Leonids must be about 33 years. Since the meteors seen in June 1916 were 10 months behind the comet, their perturbations by Jupiter in the ensuing revolution were different; the meteors made their nearest approach to Jupiter (distance 0.719) in mid-May 1918. The following are the calculated perturbations between May 1917 and May 1919:  $\Delta\Omega - 65'.9$ ,  $\Delta i + 41'.5$ ,  $\Delta\pi + 59'.5$ ,  $\Delta\omega - 13'.5$ ,  $\Delta\phi - 45'.5$ , and  $\Delta\gamma + 0.47$ . The date of the chief display went back from June 28, 1916, to June 27, 1921, in good agreement with the above change of the node. The comet itself went still nearer to Jupiter than the meteors and suffered larger perturbations. Mr. Shain considers that the indications are all in favour of connexion between the comet and meteors, and notes that a similar shower was seen in early July 1867, 1868, 1869, 1872 by several observers.

**KALOCSA OBSERVATIONS OF PROMINENCES.**—The Rev. B. G. Swindells, S. J., gives a useful summary in the *Observatory* for October of the work on prominences by Father J. Fenzi at Kalocsa from 1886 to 1917. The curve of prominence activity is synchronous with that for the spots, but the distribution is different. At minimum the chief prominence-development is in latitude  $50^{\circ}$ . There are none at the poles and few at the equator. The prominence-zone extends towards the poles as maximum approaches and, for a short time at maximum, the poles are the seat of greatest prominence-activity. But a state of quiescence soon returns at the poles, not to be disturbed for nearly 11 years. It is as though two waves of activity start from lat.  $50^{\circ}$ , one filling the equatorial gap, the other approaching the poles from all sides, so that there is a great heaping-up there, which soon collapses again. While these changes are different from those of the spots, they accord with the changes in the coronal rays, so that the latter appear to be closely connected with the prominences. In some eclipses coronal arches have been seen surrounding prominences, which is a further argument for connexion. It is not difficult to imagine that the more finely divided matter expelled in a prominence-eruption should rise to a great height under such influences as light pressure and electrical repulsion.

## Research Items.

**THE MAORI MODE OF DRILLING.**—In the last issue of the *N.Z. Journal of Science and Technology*, Mr. Eldon Best, of the Dominion Museum, contributes an article on the methods of drilling used by the Maoris. The type of drill formerly used by them was the cord drill, which was used in ancient days in India and is still employed in making the sacred fire. The pump drill and bow drill were unknown to the Maori in pre-European times. The European form of pump drill was introduced by the early European settlers. Had the Maori known the pump drill in former times, it would have been the free-bar drill used by the nations of the western Pacific. The pierced-bar form was not known in that region in ancient times, but was introduced by early European visitors and residents. Mr. Best gives three photographs showing the present use of the drill for piercing blocks of stone.

**RELATION OF TRANSPIRATION TO DRY WEIGHT IN TOBACCO PLANTS.**—Many experiments have been made to determine the relation between the rate of transpiration in a plant during its growth and the dry weight and ash content of the resulting plant. Lawes made some experiments on the subject as early as 1849. In a recent paper Mr. N. B. Mendiola (*Philippine Journ. of Sci.*, vol. 20, No. 6) describes series of experiments with tobacco plants grown in water culture, to determine the effect of a dry or humid atmosphere and of light or shade. He concludes that there is no absolute correlation between the percentage of ash, the relative rate of transpiration of the plant during its growth, and the total dry matter produced.

**PHOSPHORESCENT LIGHT OF FIREFLIES.**—Ever since the classic experiments of Langley, the light of the firefly has attracted attention on account of its presumed high efficiency and the hope that we may ultimately be able to produce synthetically substances yielding useful phosphorescent light. Some experiments by Dr. H. E. Ives, summarised in the *Journal of the Franklin Institute*, show that the brightness of the firefly is about 0.014 lumens per sq. cm. This may appear so low as to be of little practical value in comparison with the brightness of a typical white sky (about 1 lumen per sq. cm.) and it is, of course, far below the brightness of most artificial illuminants. Yet if we could obtain such a steady brightness synthetically, and cover fairly extensive surfaces with the phosphorescent substance, it would be possible to obtain a serviceable illumination. The examination of the distribution of energy in the spectrum of the firefly is attended by great difficulty owing to the feeble nature of the light. Dr. Ives employed two methods, photography with panchromatic plates and "extinction of phosphorescence," and deduced that the radiation is confined between 0.5 and 0.6  $\mu$ , which is the region of the visible spectrum where perception of light by the eye is most acute. His estimate of luminous efficiency is based partly on reasoning involving assumptions of the total energy of a glow-worm in relation to its weight, and is therefore somewhat dubious. But he conjectures that about 80 per cent. of the total radiated energy appears as visible light.

**A NEW TEXTILE FIBRE.**—The October issue of *Conquest* completes the third year of its publication, and throughout this period it has consistently carried out its purpose of setting forth the progress of science so far as it concerns our daily life. In this issue Mr. A. S. Moore directs attention to the possibilities of the new textile fibre "arghan," which Sir H.

Wickham noticed in native use in South America and introduced four years ago into the Federated Malay States, where the authorities granted 30,000 acres for its cultivation. It is a plant of the pineapple type, and its leaves split readily into fibres 5 or 6 ft. in length, which resemble silk and exceed the best hemp and flax in strength. It resists the action of sea water, and will be invaluable for nets and ship cordage; it spins and bleaches well and retains all dyes, and makes a firm cloth when woven either alone or in combination with cotton or flax.

**INDEXING SCIENTIFIC LITERATURE.**—We have received from the National Research Council of the United States the reprint of a paper by Mr. Gordon S. Fulcher on "The Indexing of Scientific Articles" which deserves notice. Mr. Fulcher does not appear to be well posted in the literature of his subject, for he places in one category the "International Catalogue of Scientific Literature," and the indexes of the H. W. Wilson Co., which are prepared on entirely different principles. For example under the scheme of "The International Catalogue" a paper on the flora of Formosa would appear under its author's name, the geographical area of its flora, and under the new genera or species described. Similarly a paper of anthropological interest would be classed under its period, locality, and subject matter. Mr. Fulcher's scheme is practically on those lines; but he goes one step further by advocating the elimination of the author and title of the paper and substituting a series of notes, dealing with the salient features of each paper, which are subsequently arranged for printing in alphabetical order. Our objections to Mr. Fulcher's system are as follows: It is "in the nature of real things to be inexhaustible in content," hence if bibliographical unities are disregarded the extent of analysis must be arbitrary, and uniformity of work and phraseology rendered very difficult. To bring it within the range of practice such a scheme must be a classification of original matter arranged under agreed subdivisions. Under Mr. Fulcher's scheme the same subject appears under two or more sub-heads, e.g. Nebulæ: origin-planetary, etc. Nebulæ: planetary-origin, etc. Neither, however, of the above methods are adapted to the indexing of scientific papers. The elimination of the author's name divests the paper of its proper authority; while the substitution of the analytical note for the author's title destroys the unity and purpose of the article. A minutely-classified file of excerpts from the scientific journals prepared by some central authority would undoubtedly prove of great national service, but an index prepared on Mr. Fulcher's lines would probably be seldom consulted.

**COLOUR FILTERS IN MICROSCOPY.**—Messrs. Kodak have just issued the sixth edition of their booklet on photomicrography. It has been revised so that it now deals with cut films instead of plates, bringing it into line with Messrs. Kodak's practice of making films only on account of the many advantages that they offer. It includes for the first time details of a set of Rheinberg's filters for differential colour illumination in microscopy. Although this method of illumination was introduced by Mr. Rheinberg some 25 years ago, Mr. Rheinberg says that this is the first time that the discs and rings have been made commercially in a suitable form and in suitable colours. The book gives within its 40 pages a great deal of information on the adjustment of the apparatus, the use and properties of colour filters of all kinds, exposure factors, and so on.

The Origin of Atmospherics.<sup>1</sup>

By R. A. WATSON WATT.

THAT abnormal outbursts of atmospherics—the "x storms" of the radio-telegraphist—were associated with convective weather was indicated by the work of the British Association Committee on Radio-telegraphic Investigations in 1914-15. That actual thunderstorms could be located by direction-finding on atmospherics was established early in a Meteorological Office investigation begun in 1915. But it has not yet been shown whether the fully developed thunderstorm is the only, a main, or merely a subsidiary source of atmospherics.

A critical examination of the data obtained in the Meteorological Office investigation referred to promises to throw some light on the question, and it has been thought desirable to give a preliminary indication of the evidence which is emerging.

The coastal direction-finding stations of the Admiralty co-operated in the investigation by reporting the apparent direction from which atmospherics were arriving whenever such a direction was observed, and when pressure of traffic permitted an observation.

Some twelve stations took part in this scheme, which began in March 1916. The examination of the results has been made for two years, April 1916 to May 1918. During this period there were approximately 1000 occasions on which three or more stations observed a direction of arrival of atmospherics within the same hour. On plotting these approximately simultaneous observations on a gnomonic chart, it is found that on almost exactly half of the occasions the three or more bearings gave an intersection in a point of a limited area, indicating a source of atmospherics at a point so determined. Actually the distribution of these intersections, according to the number of participating stations, is as follows:

Six stations giving bearings meeting in a point (within the limits of accuracy of observation)	2
Five stations giving bearings meeting in a point (within the limits of accuracy of observation)	15
Four stations giving bearings meeting in a point (within the limits of accuracy of observation)	68
Three stations giving bearings meeting exactly in a point	231
Three stations giving bearings meeting in a point after adjustment within the limits of accuracy, assumed $\pm 5$ degrees	110
Three stations giving bearings failing to meet in a point but delimiting a small area as source	62
Total number of locations	488

The geographical distribution of these apparent sources of atmospherics is:

England and Wales . . . . . 58	Central Europe and	
Scotland . . . . . 18	Balkans . . . . . 12	
Ireland . . . . . 45	Mediterranean and	
English Channel . . . . . 59	N. Africa . . . . . 44	
Bay of Biscay . . . . . 37	Iceland and Atlantic	9
France . . . . . 144	Belgium . . . . . 7	
Spain . . . . . 23	Holland . . . . . 7	
Italy . . . . . 19	Switzerland . . . . . 6	

The comparison of these locations with meteorological data is a somewhat extensive investigation and is still in progress. In 288 cases, however, the

immediately available data seemed to provide an adequate basis for discussion. In a relatively small number of cases only were thunderstorms found to have occurred in the region located as a source of atmospherics, and near the time of observation. Since the thunderstorm is a known source of atmospherics, it is not proposed to detail here these cases, particularly as it is necessary to search more closely for records of thunderstorms, which are notoriously sporadic phenomena, liable to slip unobserved through the open mesh of the network of observing stations.

Comparison was also made with the maps in the British Daily Weather Report, which show the area over which rain has fallen during the 24 hours, 7 A.M. to 7 A.M. In 239 out of the 288 cases, the apparent source of atmospherics was definitely associated with the rainfall area for the corresponding 24 hours. In 105 cases the source was on the advancing edge of the rain area, in 75 within that area, and in 59 cases it was on the rear edge. Of the remaining 49 locations, 30 were found to fall in places where thunderstorm or squall phenomena had been reported about the same time.

Thus in only 19 of the 288 cases, *i.e.* in 6½ per cent., has no meteorological relation with the source of atmospherics yet been traced, while it is also noteworthy that 10 of these 19 fell in the least trustworthy class of location, the three bearings delineating an area not negligibly small.

One is therefore faced with the alternative conclusions that—

- (1) Rainfall, without the occurrence of a fully developed thunderstorm, is an important source of atmospherics.
- (2) The climate of south-west Europe is so wet, that there is an extremely high probability of rain in a random 24 hours at a random point.

To test the validity of conclusion (2) the maps for the same two-year periods were used. Four individuals (two without knowledge of the nature of the test) were asked to carry out a blind spotting game by placing a random dot on each chart, without seeing its detail. Again, many of these dots were beyond the range of adequate data, but 335 out of 732 could be compared with data. The results show that the chances are nearly even for or against rain, the distribution of the random points being:

In rain area . . . . .	73
On advancing edge . . . . .	46
On rear edge . . . . .	62
Total associated with rainfall . . . . .	181
Total definitely not so associated . . . . .	154

It appears, therefore, to be established conclusively that a very high proportion of sharply defined sources of atmospherics are to be found in areas in which rain is falling, and particularly on the advancing edge of such areas, more than 90 per cent. in the present series being in rain areas, and 36 per cent. on the forward edge of the 24 hours' rain area. It is perhaps a permissible inference that, were one able to deal with the instantaneous advancing edge instead of the edge of the area for the day, the latter figure would be increased.

The results of this investigation fall into line with modern views of the mechanism of rainfall and thunderstorm phenomena. The separation and accumulation of charges caused by ascending currents may be readily believed to be more pronounced on

<sup>1</sup> Published by permission of the Radio Research Board of the Department of Scientific and Industrial Research.



the forward edge of a rain area, and to stop short of actual thunderstorm formation, while still being sufficiently marked for the necessary readjustment of charge to originate electro-magnetic waves. The difficulty of picturing readjustments propagating radiation of such energy content as to produce audible atmospherics at distances of more than 1000 kilometres, without producing visible lightning or audible thunder at ground stations near the source, is considerable, but not so great as the difficulty

of picturing sufficient "full scale" lightning discharges, or other known phenomena, to account for the reception of atmospherics at an annual average rate of more than one per second at a station in these latitudes.

The writer desires to acknowledge his indebtedness to the Meteorological Office and to the Radio Research Board, for providing the facilities for carrying out this work, and for granting permission to publish the results.

### X-Ray Électrons.

AMONG the items of the programme of section A of the British Association at Hull this year, there was one of outstanding interest consisting of the description of some very beautiful experiments which apparently constitute still another triumph for the quantum theory and the atomic theory of Bohr. Both M. le Duc de Broglie and Prof. R. Whiddington, who described the experiments, have recently been working on the same subject, namely, the properties of the electrons ejected from metallic atoms by the incidence of X-rays; and their results are in general agreement. The method of procedure has been to allow a beam of characteristic X-rays of known frequency, for example from a tungsten anticathode, to fall upon a prepared metallic surface, say of silver. The electrons which, as a consequence, emerge from the silver do not all possess, as Barkla at first supposed, equal amounts of energy. They thus have different velocities, and, by the well-known method of the application of a suitable magnetic field, the original mixed bundle of electrons can be differentially deflected, and spread out into a "magnetic spectrum." A focussing device is employed whereby the electrons of the same speed are concentrated upon the same part of the photographic plate, so that each line in the spectrum corresponds to a group of electrons having a definite velocity. There is a certain amount of general fogging of the plate, but the comparatively sharp lines superimposed are unmistakable. Several actual plates were shown both by M. de Broglie and Prof. Whiddington.

The interpretation of these spectra, which are of somewhat simple appearance, proves to be most important in relation to current theories of quanta and atomic structure. In the first place, the phenomenon obeys the general law of photo-electric effects, in that the velocity, and therefore the energy, of the electrons expelled depends only on the frequency, and not on the intensity, of the exciting X-radiation.

Of still greater importance is the bearing of the experimental results on Bohr's theory of atomic constitution. As is well known, this theory involves that the electrons, in number  $N$ , which surround the nucleus of an atom of atomic number  $N$ , are distributed in a certain number of regions, or layers, each characterised by the work which it is necessary to expend in order to remove an electron from the region under consideration, and bring it to the exterior of the atom. If we denote by the letters  $K$ ,  $L$ ,  $M$ , etc., the levels of these regions, we can attribute to them energies of extraction  $W_K$ ,  $W_L$ ,  $W_M$ , etc. The fundamental principle underlying the production of the magnetic spectra above mentioned will be made clear by quoting from M. de Broglie's remarks:

"What appears to happen is that if radiation of frequency  $\nu$  strikes one of these electrons, situated, for example, in the region  $K$ , it communicates energy equal to  $h\nu$  in order to extract the electron from the

atom; it is clear that the corpuscle, once removed from the atomic edifice, will possess a resultant energy equal to  $h\nu - W_K$ ."

In this, of course,  $h$  is Planck's constant, and the resultant energy of the electron, which proves to have the value specified, is that which is measured experimentally by means of the magnetic deflection. For truly monochromatic X-radiation, the magnetic spectrum would thus consist of a few lines, corresponding to the various different regions in the atom from which electrons may be ejected, *i.e.* to the various possible values of  $W$ . Unless  $h\nu$  is greater than  $W$  the radiation is incapable of extracting electrons from the atomic region in question. This proves to be true experimentally; unless an anticathode is used for which the frequency of the characteristic radiation is sufficiently large in relation to at least some of the energies of electron extraction for the irradiated metal, no magnetic spectrum appears. With a Coolidge tube as the source of X-rays it has not been possible to make  $h\nu$  large enough to extract the more deep-seated electrons in metallic atoms of high atomic number; but the employment of  $\gamma$ -rays, with their much greater frequency, has enabled Ellis to extend the process to these regions; and to prove in this case also the validity of the general relation.

The lines in the magnetic spectra are usually composite. This arises from the fact that the X-rays used are seldom monochromatic, the characteristic radiation from the anticathode having several components. Again quoting M. de Broglie:

"Each line of the spectrum of the incident X-rays re-echoes on each level of the illuminated atom in such a way that we obtain at once an analysis both of the spectral lines of the illuminating beam and of the Bohr levels of the illuminated atom."

The method, as M. de Broglie pointed out, serves for measuring, without the intervention of a crystal, the frequency and wave-length of X-radiation. It thus furnishes a means of checking the magnitudes of the crystal spacings which form the basis of X-ray analysis.

The papers of M. de Broglie and Prof. Whiddington evoked great interest in the Section. There was some discussion, particularly with reference to the general fogging of the magnetic spectrum plates, which seemed to point to some of the ejected electrons having all sorts of emergent velocities. Prof. Lindeman suggested the possibility of having to assume that in the atom there were numerous electron levels, instead of the comparatively small number assumed by Bohr. Sir Ernest Rutherford, however, was satisfied that no such explanation was needed, for the reason that the fogging was inevitable, owing partly to the general radiation from the anticathode, and partly to the fact that some of the ejected electrons would lose random amounts of energy from various causes along their paths to the photographic plate.

A. O. RANKINE.

## Correlation of the Social Sciences.

A CONFERENCE was held at Oxford on October 7-9, under the auspices of the Sociological Society, with the view of securing proper correlation between the various sciences contributory to the science of sociology. Dr. A. J. Carlyle, of University College, Oxford, acted as local secretary, and other Oxford men, such as Prof. J. L. Myres and Dr. R. R. Marett, helped in the work of organisation. The Warden of New College gave the opening address. History, geography, biology, psychology, philosophy, anthropology, economics, and political science—all these subjects were considered, the reading of a paper on each being followed by a discussion.

Mr. J. S. Marvin emphasised the need for a constant return of the sociologist to history; in history we saw sociological principles in action. He pointed the difference between the two methods by showing how the biography of a great man like Napoleon, say, could be material for history or for sociology, according to the way in which it was treated. Sir Halford Mackinder (in contradistinction to some of the other speakers) made very modest claims for geography, merely pointing out that it was a limiting factor in sociological matters. Mr. J. S. Huxley attempted to show the principles which are common to human and non-human biology. He stressed the biological differences between man and other organisms as against the resemblances, and rebutted the claims of those who seek to make the struggle for existence the most important biological principle. Further, he pointed out that the general direction observable in organic evolution provided an objective criterion for ideas of progress in social science. Prof. Myres was emphatic on the need for a biological basis for any true science of sociology.

Dr. Marett read a very stimulating paper on anthropology, laying stress on the fact that anthropologists were now coming more and more to adopt what might be called sociological methods, in that they were investigating whole cultures instead of isolated actions or beliefs. He made it clear that the only essential distinction between anthropology and sociology to-day is that the former investigated primitive peoples, while the latter is concerned with the greater complexity of civilisation.

Prof. Spearman made large claims on behalf of psychology, and drew a vivid (if somewhat unpleasing) picture of a future state of society in which the ability of every boy and girl would be gauged, and their occupations found for them by the application

of mental tests. This would bring about a state of affairs in which the just claims of democracy would be realised, together with the merits of aristocracy.

Prof. Leonard Hobhouse, in an attempt to lead the conference back to fundamentals, insisted that the primary difference between science and philology was that the latter introduced the idea of values—a statement which provoked an interesting discussion.

Prof. W. J. Roberts, in discussing economics, pointed out that a broad treatment of the subject was necessary, particularly in order to prevent the common mistake of students of regarding the existing state of affairs as approximately ideal. Historical and sociological aspects of the science should be stressed.

Finally, Dr. Carlyle, in a characteristically amusing and vigorous address, dealt with political science.

The conference was obviously a success, in that it stimulated thought and discussion, and was profitable to those who took part in it. But the subjects treated were so large, the modes of treatment so varied, that many were doubtful whether much advance had been made by its close along the path of correlation.

Mr. Graham Wallas, in opening one of the debates in his most refreshing manner, made a suggestion which may prove fruitful. He pointed out that those who presented papers were given much too free a hand—that they could say what they liked, and that, as a matter of fact, this was usually not what the sociologists wanted to know. He suggested that sociologists should draw up *questionnaires* asking for answers on certain definite points from the anthropologists, the psychologists, the biologists, and the rest.

It is clear that sociology can become a most important science, and that its field is one left severely alone by other sciences. But it has to accept the data of a great many special sciences, to take them on trust, and then to correlate them in a particular way. It is to be hoped that the Sociological Society will adopt some such plan as that of Mr. Wallas, pinning the experts down to answering certain problems on which it must have light. This might be done at next year's conference; and the year after another might be held to deal with the purely sociological task of synthesising and employing these data.

## The Effect of Deformation on the Ar 1 Change in Steels.

THERE is considerable evidence as to the existence of lag in the crystallisation of pearlite, particularly in hypoeutectoid steels. Cooling curves show it in the observed temperature of the change, which depends on the rate of cooling. Microscopical observations testify to it in that the presence of carbide nuclei within the austenite (gamma iron) areas leads to crystallisation of globular pearlite at a temperature considerably higher than that at which growth occurs in the absence of such nuclei. Moreover, the growth of lamellar pearlite when once started does not occur simultaneously throughout the specimens. The change proceeds gradually, and there is no difficulty in quenching a specimen so that it contains areas both of pearlite (transformed) and martensite (partially transformed) intermixed.

In taking cooling curves, the specimen is usually allowed to cool undisturbed, and Mr. J. H. Whiteley

has conducted an investigation to test whether the temperature of the change could be raised and the rate of pearlite growth increased by deforming steels in this metastable zone. Recently A. F. Hallmond, in discussing the question of delayed crystallisation, remarked that for super-saturated solid solutions, violent mechanical working may be the analogue of agitation. In Mr. Whiteley's experiments, described before a recent meeting of the Iron and Steel Institute, two methods of deformation were used, namely, hammering and bending. Tests were carried out in a small, electrically heated, vertical furnace, resting on a block of steel. A bar of hard chromium steel was used as an anvil, separated from the steel block by a thick pad of asbestos. Temperatures at the surface were measured. A rod of manganese steel selected because it is non-magnetic was used to transmit the hammer blows to the specimen on the anvil. In

carrying out the deformation by hammering, two small specimens, each weighing about one gram, were used. The temperature was raised to 900° C. and then lowered in about ten minutes to 695° C. After fifteen minutes the manganese steel rod was carefully placed on one of them, and a smart blow given with a hammer. To neutralise the effect of any slight difference in temperature between the end of the rod and the pieces, the rod was also placed on the other, but no blow was given. The positions of the two pieces were then interchanged. After an interval of ten minutes, the temperature still being 695° C., the above procedure was repeated in varying order about six times, and after a further five minutes the specimens were quenched in water. The deformations produced were comparatively small, not exceeding  $\frac{1}{15}$  of an inch. Repeated experiments all agreed in showing that the lag at Ar 1 was diminished by this slight deformation. The author shows two photomicrographs. In one of these (the hammered specimen) fully half the austenite areas have been converted into pearlite. In the other (an unhammered piece) only one such area has undergone a change.

The same apparatus was used in the deformation by bending experiments. A V-shaped notch,  $\frac{1}{8}$  of an inch deep, was cut in the top of the anvil, and the end

of the manganese steel rod was shaped like a chisel. The metal used was a mild steel strip  $\frac{1}{2}$  in.  $\times$   $\frac{1}{16}$  in.  $\times$   $\frac{1}{16}$  in. This was placed across the notch, heated to 900° C. and cooled to 695° C. After fifteen minutes the rod was placed upon it so that the end was in line with the notch, and two or three light blows were given with the hammer. In this way the strip was bent to an angle of about 60°. After a further five minutes at 695° C. the strip was taken out and quenched. This experiment was made repeatedly, always with the same result. At the bend, as shown in the author's photomicrograph, pearlite was always present, but in the limbs where the metal had not been distorted, the structure consisted almost entirely of ferrite and martensite. A similar but less pronounced effect was produced when strips were bent while being maintained at a temperature of 700° C.

The author states in conclusion that although lag was reduced, it was not completely eliminated by the methods of deformation used, since, in a previous investigation with the same steel, globular pearlite was found to grow between 705° and 708° C. when carbide nuclei were present in the austenite. Both hammering and bending tests, however, agree in showing that the lag at Ar 1 can be appreciably diminished through deformation.

### Medical Education.

THE professional course has grown so full in the training of a medical student that it has become increasingly difficult to cover the ground and secure qualification in a reasonable time. Some years ago this fact raised in an acute form the position of the preliminary examinations in the pure sciences. If these examinations were abolished, or placed outside the professional course, obviously a gain in time would result for abler students. The best account of the matter is to be found in the appendix to the fifth report of the Royal Commission on University Education in London—especially under the evidence of Sir H. Morris, Mr. Flexner, and others. The practice in other countries in regard to the preliminary sciences is also clearly described.

The new regulations of the General Medical Council in regard to student registration presumably indicate the conclusions of that body on the problem. The preliminary sciences are retained, but two of them are placed outside the professional course; at the same time the age of student registration is raised to seventeen years. The examinations in chemistry and physics must be passed *before* registration but *after* the examination in general education. Biology may not be taken until after registration.

The examinations in these preliminary sciences must be conducted or recognised by one of the existing licensing bodies. It remains to be seen what provision the licensing bodies will make for these pre-registration examinations. The Conjoint Board has not yet issued its regulations. Student registration is, of course, at present not legally obligatory,

but the older licensing bodies, such as the Universities of Oxford and Cambridge, usually conform so far as possible to the requirements of the General Medical Council. It is at present unlikely that either Oxford or Cambridge will alter its current practice. Each will continue to conduct its present preliminary examinations and postpone student registration until after they have been passed.

These examinations can all of them now be taken under certain conditions before residence is begun. This comparatively recent concession on the part of these universities leaves their candidates practically unaffected by the new General Medical Council regulations. Boys going to these universities will postpone registration until after passing the preliminary examinations instead of, as at present, registering when they have passed the general education examination. It is not unlikely, however, that both Oxford and Cambridge may extend recognition to biology in their own Higher Certificate examinations—they will inevitably do so some day. This would prevent a hardship which may occur at present to a boy who can only proceed to the university if he wins a scholarship. The university scholarships are open up to nineteen years of age. If a boy waits for these and is unsuccessful, he would have obtained his qualification more quickly by leaving school at seventeen years of age and proceeding straight to a hospital. If he is allowed a certificate for all the preliminary sciences on the Higher Certificate examination, such a boy would lose less time.

### The Chilean Earthquake.

FROM the first accounts which have reached this country, it is evident that one of the world's greatest earthquakes occurred shortly before midnight on November 10-11 off the coast of Chile. As in all such earthquakes, the duration of the shock was considerable—nearly three minutes at Valparaiso and four minutes at Caldera—but it should be remembered that such estimates may include some of the immediately succeeding after-shocks. There can be no doubt, however, as to the great extent of the disturbed

area. Along the coast, the shock was felt from Antofagasta to Valdivia, a distance of 1100 miles. It was felt across the continent at Buenos Ayres, where it was strong enough to stop clocks. As this city is about 900 miles from Coquimbo (which appears to be near the epicentre), the disturbed area must contain more than 2½ million square miles. The shock is also said to have been felt at Hilo, in Hawaii, but, without further and much stronger evidence, the statement may be discredited. The district over

which houses were damaged was also large, though perhaps not unusually large. The zone most affected was that between Coquimbo and Chanaral, the latter place being nearly 100 miles north of Coquimbo, but houses were also slightly damaged at Valparaiso, which lies about 2.40 miles to the south.

In this earthquake, as in so many others on the western coast of America, it is difficult in the early accounts to separate the effects of the shock from those produced by the sea-waves and by the fires that followed the earthquake. The sea-waves were observed along the coast from at least Antofagasta on the north to Talcahuano (near Concepcion) on the south, a distance of nearly a thousand miles. They were large enough to wash away boats at Hilo in Hawaii. All the submarine cables along the coast appear to be broken, but the statement that soundings taken between Copiapo and Caldera gave a depth of 86 fathoms, instead of 2800 fathoms as marked on the chart, must of course be erroneous. The earthquake resembles its predecessors in its submarine origin some distance from the coast.

### University and Educational Intelligence.

**BIRMINGHAM.**—The following appointments have been made by the Council: Mr. A. W. Nash, lecturer in oil mining; Dr. E. Ashley Cooper, lecturer in public health chemistry; and Mr. D. R. Nanji, assistant lecturer and demonstrator in the department of brewing and the biochemistry of fermentation.

**CAMBRIDGE.**—Mr. G. C. Steward has been elected to a fellowship at Gonville and Caius College, and Mr. G. Udney Yule, Mr. J. E. P. Wagstaff, and Mr. W. M. H. Greaves to fellowships at St. John's College.

**LONDON.**—The Senate invites applications for a new University Chair of Anatomy tenable at St. Bartholomew's Hospital Medical College, which has not hitherto had a professor of the subject attached to it. The present University professors of anatomy are as follows: Prof. E. Barclay-Smith, King's College; Prof. J. E. S. Frazer, St. Mary's; Prof. T. B. Johnston, Guy's; Prof. F. G. Parsons, St. Thomas's; Prof. G. Elliot Smith, University College; Prof. W. Wright, London; and Prof. T. Yeates, Middlesex. The full title of the holder of the chair at St. Bartholomew's will be "Professor of Anatomy in the University of London." The appointment will date from September 1, 1923, and will be subject to the statutes and regulations of the University and to the regulations of St. Bartholomew's Hospital Medical College. The professor will be expected to devote his whole time to the duties of the chair, except that he may be permitted to hold examinations in anatomy, and will be able to devote time to research. The salary of the chair will be 1000*l.* per annum. Arrangements for assistance and for departmental expenditure are made by the Medical College of St. Bartholomew's Hospital in consultation with the professor. Applications for the chair (12 copies) must be received not later than first post on April 16, 1923, by the Academic Registrar, University of London, South Kensington, London, S.W.7, from whom further particulars may be obtained.

**ST. ANDREWS.**—Mr. Rudyard Kipling has been elected Rector in succession to Sir James M. Barrie.

**SHEFFIELD.**—Mr. R. Stoneley, assistant lecturer in mathematics, has been appointed curator of the University Observatory.

**PROF. ALFRED TENNYSON DELURY**, head of the department of mathematics, University of Toronto, was in June last appointed Dean of the Faculty of

Arts of that University. Sir Robert Falconer, president of the University, called a meeting of the Council of the Faculty of Arts and announced that, while the appointment of a Dean was by statute in his hands, he would like to receive nominations from the Council for an appointment to this important post. Nominations were accordingly made and balloting was carried on by mail.

The first meeting of the Court of Governors of the University College of the South-West of England, Exeter, was held on October 27. The new governing body takes over the former Royal Albert Memorial College, Exeter, with its hostels and other property, and also enters into possession of the site and mansion-house given by Mr. W. H. Reed for the purposes of the new college buildings. The new University College which, on the recommendation of the University Grants Committee, has been placed upon the Treasury list of Universities and University Colleges as from August 1, 1922, is regarded as the first step towards the establishment of a University in the South-West of England. H.R.H. the Prince of Wales and Duke of Cornwall is president of the college, and sent a message of greeting and good wishes on the occasion of the first meeting of the court. The court elected Sir Henry Lopes, Bart., as deputy-president of the college; and one of the vice-presidents is Sir Arthur Quiller-Couch. The deputy-president made a statement to the court as to the present position and prospects of the college, emphasising his view that the governing principle of college policy should be the attainment, as soon as possible, of a status which would free the college from a purely external degree system, and indicating the possibilities of co-operation to this end among the various higher educational institutions in the south-western countries. A very substantial increase in the number of full-time degree students in attendance at the college was reported.

On the occasion of the transfer of the Imperial Department of Agriculture from Barbados to Trinidad, following upon its amalgamation with the West Indian Agricultural College, Sir Francis Watts, principal of the College and Commissioner of Agriculture, received a letter from the Acting Governor of Barbados in which the latter stated that the department's work "has been a landmark in the history of the West Indian Colonies." He continued, "I beg also to be allowed to express the cordial gratitude of the Government of Barbados for the valuable and ready assistance which the Imperial Department has rendered the local Government on numerous occasions . . . may I also assure you of the warm good wishes of the Barbados Government for the success and prosperity of the Agricultural College in which the Department will now be merged, and of our confident hope that the establishment of the College will prove to be a great step forward in the development of scientific tropical agriculture not only in the West Indies but also in a wider field."

The Royal Technical College, Glasgow, publishes for the session 1922-23, in a calendar comprising 356 closely printed pages, a vast amount of information relating not only to the courses of instruction it offers, the conditions under which the diplomas and degrees for which it prepares are obtainable, and the scholarships tenable in it, but also to the appointments now held by its past students. The list of past students and their appointments, including nearly a thousand names, affords convincing evidence of the practical value of the instruction given, and should be of great interest alike to past, present, and prospective students.

## Calendar of Industrial Pioneers.

**November 19, 1883.** Sir William Siemens died.—One of four brothers who were all closely associated with the application of science and the management of great industrial concerns, Siemens was born in Lenthe, Hanover, on April 4, 1823. He settled in England in 1844 and in 1859 became a naturalised British citizen. His name is connected with the introduction of the regenerative furnace for steel-making and the enunciation of the principle of the modern dynamo. He designed the cable ship *Faraday*, and was president of various technical institutions.

**November 20, 1713.** Thomas Tompion died.—The father of English watch-making, Tompion began his apprenticeship in London in 1664 and by 1675 had gained a foremost place among his fellow mechanicians. He supplied the first clocks to the Greenwich Observatory, and under Hooke's direction made one of the first English watches with a balance spring. His work made English watches the finest in the world. He is buried in the nave of Westminster Abbey, in the same grave as his famous pupil and successor, George Graham.

**November 20, 1898.** Sir John Fowler died.—A great railway engineer, and jointly responsible with Baker for the design of the Forth Bridge, Fowler's early work was done in the Sheffield district, while he afterwards became engineer to the Metropolitan Railway.

**November 21, 1555.** Georg Agricola died.—Agricola has been called the Bessemer of his age. He was born in Saxony in 1494, studied medicine at Leipzig and in Italy, and practised in Bohemia. Subsequently he abandoned his profession, became absorbed at Chemnitz in the study of metals and mining, and was given a pension by the Duke of Saxony. He collected specimens of ores, studied their chemical characters, and described them accurately. His work, "De re Metallica," is considered the most important technical book of the sixteenth century.

**November 21, 1863.** Samuel Hall died.—A native of Basford, Nottingham, Hall made a considerable fortune by his invention of a method of gassing lace and net. In 1836 he took out a patent for a surface condenser for ships which embodied most of the features of condensers as in general use to-day.

**November 23, 1902.** Sir William Chandler Roberts-Austen died.—The successor of Graham as chemist to the Mint, Roberts-Austen did much valuable work on the study of alloys, and was regarded as an authority on all that appertains to coinage. He delivered many important lectures, and in 1899-1900 served as President of the Iron and Steel Institute.

**November 24, 1916.** Sir Hiram Stevens Maxim died.—One of the greatest inventors of the nineteenth century and a pioneer worker on the flying machine, Maxim, like Edison and Swan, assisted to introduce the electric light, and then, turning his attention to the construction of an automatic gun, brought out his Maxim gun, which ever since has played so important a part in all warfare. He was also the first to combine nitroglycerine and true gun-cotton in a smokeless powder.

**November 25, 1893.** Johann Bauschinger.—A distinguished investigator of the strength of materials and the founder of the International Association for Testing Materials, Bauschinger was born in Nuremberg in 1834, and for twenty-five years was professor of mechanics and graphic statics at the Technical High School at Munich. E. C. S.

## Societies and Academies.

LONDON.

**Royal Society, November 9.**—Sir Charles Sherrington, president, in the chair.—H. E. Armstrong: Studies on enzyme action. XXIII. Homo- and hetero-lytic enzymes.—A. V. Hill and W. E. L. Brown: The oxygen-dissociation curve of blood and its thermodynamical basis. An attempt has been made to test the validity of the hypotheses (i) that the reaction of hæmoglobin with oxygen is represented by the equation  $(\text{Hb})_n + n\text{O}_2 = (\text{HbO}_2)_n$ , where Hb represents the simplest possible molecule of hæmoglobin (containing one atom of iron), and  $n$  the average degree of polymerisation of the molecule in the presence of the salts in blood; and (ii) that the dissociation curves of oxyhæmoglobin under various conditions can be deduced by simple application of the Laws of Mass Action. The heat of reaction  $q$  of one gm. mol. of hæmoglobin  $(\text{Hb})_n$ , with oxygen has been determined by the application of the van't Hoff isochore to the effect of temperature on the dissociation curve of blood, while the heat of reaction  $Q$  of one gm. mol. of oxygen with hæmoglobin has been measured directly in a calorimeter. The value of  $q/Q$  is practically equal to  $n$  determined in other ways, affording strong confirmation of hypothesis (i). The apparent heat of reaction of oxygen with blood may be very considerably reduced by the driving off of carbon dioxide by the more acid oxyhæmoglobin formed. A direct measurement of the heat of combination of carbon dioxide with blood confirms the theory that carbon dioxide combines with blood by taking base from the ionised hæmoglobin salt to form bicarbonate, leaving the non-ionised hæmoglobin acid. The heat of combination of carbon monoxide with hæmoglobin in blood is about 50 per cent. greater than that of oxygen: this proves that temperature affects the equilibrium of oxygen and carbon monoxide with blood.—H. Hartridge and F. J. W. Roughton: The velocity with which carbon monoxide displaces oxygen from its combination with hæmoglobin. Pt. I. When light falls on a solution containing oxyhæmoglobin and carbon monoxide hæmoglobin, the incoming light energy changes the position of equilibrium, tending to cause a reduction in the amount of the latter with a corresponding increase of the former. In the dark the original position of equilibrium is gradually recovered, the rate of return depending on the velocity constants of the reactions. By determining the percentage saturation of the hæmoglobin with carbon monoxide gas at intervals after the light has been turned off, the velocity constants can be calculated. This is done by causing the fluid to flow through two glass tubes in series; in the first it is exposed to a powerful light, while in the second it is kept in the dark, so that the original position of equilibrium is gradually regained. The percentage saturation with carbon monoxide gas of the solution at different parts of the "dark" tube was determined with the reversion spectroscope. At 15° C. the two velocity constants had mean values of 0.0067 and 0.55 respectively. At 34.5° C. the value of  $K_2$  was 2.66, which gives a temperature coefficient for this velocity constant of 2.3 for a 10° C. rise of temperature,—approximately that given by many ordinary chemical reactions. Pt. II. The method of measuring the velocity of the reaction  $\text{CO} + \text{O}_2\text{Hb} = \text{COHb} + \text{O}_2$  consists in ascertaining, by means of an electrically controlled stop-watch, the time taken for the equilibrium to shift from an unstable position to a stable one, the change being ascertained by

measurements on the absorption bands by means of the reversion spectroscope. The system was changed to an unstable position by (1) subjecting the solution to the action of a powerful beam of light, and by (2) suddenly obstructing the light rays. Thus chance fluctuations in the catalysing light source, and in the flow of the liquid under observation were avoided, but it was difficult to make accurate estimations on absorption bands moving from one position in the spectrum to another. Observations of the equilibrium constant were made by method (1) at 1° C. and laboratory temperature, and by method (2) at laboratory temperature and 34° C. At laboratory temperature, method (1) gave 0.51 and 0.59, and method (2) 0.44 and 0.40. The temperature coefficient per 10° C. calculated from values obtained by method (1) was 2.3, while method (2) gave 2.5 and 2.7.—L. T. Hogben: Studies on internal secretion. I. The effect of pituitary (anterior lobe) injection upon normal and thyroid-ectomised axolotls. While pituitary feeding has no influence on the metamorphosis of medium-sized or sexually mature axolotl larvæ of *Amblystoma tigrinum*, injection of anterior lobe extracts into axolotls of the same ages and dimensions was followed by the assumption of the adult characteristics, with rapidity comparable to metamorphosis induced by thyroid administration, and beginning about two to three weeks after the initial injection. Anterior lobe extracts also induce metamorphosis in thyroidless larvæ. Spontaneous metamorphosis does not generally occur, as Marie de Chauvin stated, in larvæ of six to nine months when placed in shallow water with opportunities for emerging.—L. T. Hogben and F. R. Winton: The pigmentary effector system. II. Apart from caffeine, the only reagents found to induce melanophore contraction were those known to excite peripheral sympathetic nerve-endings, namely, adrenalin, tyramine, ergotamine, and cocaine. Apart from pituitary extract, the only reagents found to bring about melanophore expansion were apocodeine and nicotine, in quantities sufficient to paralyse all sympathetic nerve-endings. No unequivocal direct evidence is advanced that nervous control of pigment responses in Amphibia has been found. Synchronous colour changes of Amphibia in response to normal environmental stimuli are possibly determined mainly by endocrine influences.—A. Fleming and V. D. Allison: Further observations on a bacteriolytic element found in tissues and secretions. Strains of *M. lysodeikticus* resistant to lysozyme action can readily be developed. The resistance is not specific, i.e. strains made resistant to one tissue or secretion are equally resistant to all tissues, whether derived from man, the lower animals, or from vegetables, showing that the lysozyme affecting *M. lysodeikticus* is the same whatever tissue it is derived from. After solution of a large number of *M. lysodeikticus* there is an increase in the lytic power of the fluid, which affects wholly or mainly the homologous microbe. Different tissues and secretions vary in their capacity to dissolve different bacteria, and some tissue extracts have a marked lytic action on many of the well-known pathogenic bacteria.

## PARIS.

Academy of Sciences, October 23.—M. Albin Haller in the chair.—Ch. Barrois, P. Bertrand, and P. Pruvost: Observations on the coal measures of the Moselle.—W. Kilian: The stages of the retreat of alpine glaciers and the origin of Lake Lauvital (Oisans).—A. Angelesco: A functional property of conics.—E. Merlin: Some properties of networks.—M. Desaint: The general representations

of analytical functions.—P. J. Myrberg: The singularities of automorphic functions.—Frithiof Nevanlinna: The relations which exist between the distribution of the zeros and the poles of a monogen function and the increase of its modulus.—Alf. Gulberg: A theorem of M. Markoff.—Constant Lurquin: The criterium of Tchebycheff.—MM. Constantin, Joessel, and Daloz: A boat which moves against the wind using the wind itself as motive power. The motor is an air turbine of 9 metres diameter connected with a screw propeller by gearing. No drawings or details are given, but it is stated that a small 6-ton fishing-boat fitted with the motor has given successful results on trial.—L. de Broglie and A. Dauvillier: The spectral system of the X-rays. The proposed system is based on the principle of rigorous alternation of regular and irregular doublets (Wentzel), following the views of Smekal and of Rubinovitz. The table given includes some lines predicted from the theory but not yet observed.—M. Vuillaume and A. Boutaric: The photometry of sources of light constituted by black bodies at different temperatures.—R. Mesny: The generation of polyphase oscillations of high frequency by electronic tubes.—André Charriou: The separation of ferric oxide and alumina from magnesia by the method of nitrates.—M. Picon: The action of sodammonium on hexamethylenetetramine, tetramethyldiaminomethane, and ethyldiethylimine. Sodammonium, in liquid ammonia, is without action on hexamethylenetetramine at the ordinary temperature. The imine  $\text{CH}_3 \cdot \text{CH} : \text{N} \cdot \text{C}_2\text{H}_5$ , derived from acetaldehyde and ethylamine, is attacked by sodammonium giving diethyldiaminobutane.—Pereira de Sousa: The basic rocks of the nepheline syenite massif of the "Serra de Monchique."—Paul Lemoine and A. Pinard: The mode of contact of the chalk and pisolithic limestone at Meulan-Gaillon (Seine-et-Oise). The limestone has filled irregular pockets in the chalk, and a section of one such pocket is given.—Mlle. F. Brepson: The rôle of the phenomena of solifluxion in the model of the region of Saulieu (Morvan). The formation of ponds and lakes in this district cannot be explained as being due to the erosion of streams, nor is there any evidence of glacial action, and it is suggested that earth slides may have been the cause of this formation. The products of granite disintegration imbibe water freely and have a tendency to slip down the steep slopes, forming ridges known as *rideaux*. Examples of these phenomena in the neighbourhood of Saulieu are given, and this is considered to afford an explanation of the large number of small lakes in the district.—J. Lacoste: New radiogeometric observations of atmospherics. An application of wireless telegraphy to the prediction of storms.—René Souèges: The embryogeny of the Carophyllaceæ. The first stages in the development of the embryo of *Sagina procumbens*.—Marcel Mirande: The relation existing between the relative acidity of the tissues and the presence of anthocyanine in the scales of lily bulbs exposed to light.—André Guillaume: Study of the limits of vegetation in the north and east of France. A study of the conditions limiting certain plants to certain areas. Meteorological, geological, physical, and palæontological influences are discussed, the effect of climate being the most important.—Med. Gard: The withering of young walnut trees in 1922. In the spring of this year there were heavy losses in young walnut trees. This does not appear to have been due to disease, as was at first suspected, but is attributed by the author to autumnal frosts.—G. Vernet: The rôle of calcium chloride in the coagulation of the latex of *Hevea Brasiliensis*. The addition of solutions of calcium

chloride to the latex of Hevea increases the rapidity of the coagulation and also the total weight of rubber obtained. The causes of these results are discussed.—**Émile F. Terroine** and **H. Barthélemy**: Avitaminosis and inanition. Two views of the action of vitamins have been put forward, one regarding these substances as indispensable for nutrition, the other as affecting the secreting power of glands and the diastatic properties of the digestive juices. According to the latter view, the nerve troubles and death resulting from feeding on polished rice are due to starvation caused by the inability of the intestine to assimilate the food. The authors use as a test for death by starvation the percentage of fats and lipid substances in the animal, and find that in cases of avitaminosis neither the nerve troubles nor death can be wholly attributable to inanition.—**M. Marage**: Phonation and telephonic audition. The author's results are in agreement with those of Fletcher, although the methods employed are absolutely different.—**A. Policard**: The working of the adipose tissue. Researches on the nuchal gland of rodents.—**M. Vila**: Separation of the globulins of horse serum. The globulins are removed from the diluted serum by treatment with three volumes of cooled acetone, and these can be separated into fractions by treatment with dilute hydrochloric acid.—**Y. Manouelian** and **Jules Viala**: A case of hydrophobia in a lioness.—**René Zivy**: An unpublished method of preparing vaccine. Sterilisation is produced by repeated freezing at  $-18^{\circ}$  C. and thawing. Pneumococcus was the most readily sterilised (two freezings), while enterococcus, the most resistant, required six.—**Marcel Leger** and **A. Baur**: Healthy carriers of the plague bacillus. A proof that negroes in Senegal, quite free from any clinical signs of plague, carried the Yersin bacillus and could act as plague carriers.

## SHEFFIELD.

**Society of Glass Technology** (York Meeting), October 18.—**Prof. W. E. S. Turner**, president, in the chair.—**J. A. Knowles**: Processes and methods of medieval glass painting. Medieval window glass differs from modern glass in that whereas the ancient material was a potassium-calcium-silicate, modern glass is a soda-lime glass. The northern school of glass-painting situated at York in the middle ages obtained glass from the northern Continental glass-making districts of Hesse and other Rhenish provinces. The London school drew it from Lorraine, Burgundy, and Normandy. The uncoloured glass used in the north was much whiter than that employed in the south, probably due to the use of English-made white glass from the works at Chiddingfold. The present-day glass maker can produce colours with a certainty and in a far greater range of tints than the medieval craftsmen could. With the exception of the red or "ruby" glass, the medieval coloured glasses were those which were most easily produced. Being made from native oxides which contained other metals as impurities, the resulting colours were not pure or always harmonised. The colours such as red, blue, and green were contained in the glass itself, but details such as the face, folds of drapery, and ornamental work were painted on with a brown vitrifiable pigment, formed of a metallic oxide such as red oxide of iron or black oxide of copper, mixed with a soft glass known as "flux." In the kiln the flux melted before the glass itself, and attached the black oxide to the surface.—**H. J. Powell**: Modern developments in the making of stained and painted glass. The substance of much medieval window glass decays though many pieces of ancient Roman glass are

sound. Some medieval glass has become partly or wholly opaque, and crumbles to powder. The most defective glass belongs to the fourteenth century. All the forms of decay originate from the excessive proportion of alkali in the glass mixture which causes the glass to be hygroscopic.

## WASHINGTON, D.C.

**National Academy of Sciences** (Proc., Vol. 8, No. 10, October 1922).—**H. Blumberg**: New properties of all real functions. Descriptive and metric properties of planar sets and real single-valued functions of two real variables, with some generalisations, are discussed.—**C. N. Moore**: Generalised limits in general analysis. A proof is given of a generalisation of a theorem in the theory of divergent series.—**Martha Bunting**: Preliminary note on Tetramitus, a stage in the life cycle of a coprozoic amoeba. Coprozoic amoebae in caecal material from a rat were cultivated on an artificial medium. Amoebae containing at least one large contractile vacuole emerge from cysts, commonly spherical, the walls of which apparently dissolve. Prior to division, the amoeba becomes homogeneously refractive ("gel" state). After division, individuals may become amoebae or develop flagellae. The flagellate form is thought to be identical with *Tetramitus nostratus* Perty; it reproduces by longitudinal fission after passing through a "gel" state. Eventually the amoeboid form is reassembled. Reproduction of both forms appears to be indefinite but the amoebae finally encyst.—**Raymond Pearl** and **T. J. Le Blanc**: Further note on the age index of a population. The numerical index of the age distribution of a population previously proposed by Pearl has been used successfully employing six to eight age groups covering the life span. Statistics from the 1915 census of Iowa show that it is also trustworthy, using only three age groups; there is high correlation between the values of the index for coarse and fine age groupings.—**A. A. Noyes** and **H. A. Wilson**: Thermal ionisation of gaseous elements at high temperatures; a confirmation of the Saha theory. It has been shown that the conductivity of flames into which salt solutions are sprayed is (a) independent of the acidic constituent of the salt; and (b) changes with the concentration of the salt in accordance with the equilibrium constant obtained when the substance, its ions and electrons, as represented by the equation  $M = M^+ + e^-$ , are regarded as perfect gases. Substantially, the whole conductivity is due to the electrons present. From (b) relative values for the ionisation constants of five alkali elements are calculated; the series is closely parallel to that obtained from thermodynamical equations utilising ionisation potentials as employed by Saha.—**E. H. Hall**: An electron theory of electric conduction in metals. It is assumed that an ion is formed from a metal atom by loss of an electron from the outer shell, leaving a pit in the ion which renders it unsymmetrical. An imposed electric field turns the ions so that the pits move as a positive charge would do, giving the effect of an electric current. Ohm's law can be justified, and an explanation is offered of the variation of metallic resistance with temperature. Rise of temperature probably directly increases resistance rapidly, while the increased number of ions produced tends to reduce it.—**C. Barus**: Static deflection, logarithmic decrement and first semi-period of the vacuum gravitation needle. These three quantities are similar time functions with a period of one day; they are largest in the morning and least at night. Static deflection and logarithmic decrement appear to be nearly proportional, while the latter and the first semi-period also form a definite curve.

## Official Publications Received.

The Science Reports of the Tôhoku Imperial University, Sendai, Japan. Second Series (Geology), Vol. 7, No. 1: Notes on some Mesozoic Plants from Japan, Korea, and China, in the Collection of the Institute of Geology and Palaeontology of the Tôhoku Imperial University. I. By H. Yabe. Pp. 28+4 plates. (Tokyo and Sendai: Maruzen Co., Ltd.)

Department of Agriculture. Report of the Director of Agriculture for 1921. Pp. 58. (Peralambina, Cebu.)

Ministério de Agricultura, Indústria e Commercio: Directoria de Meteorologia. Boletim Meteorológico: Anno de 1915. Pp. viii+137. (Rio de Janeiro.)

The South-Eastern Naturalist: Being the Twenty-seventh Volume of the Transactions of the South-Eastern Union of Scientific Societies including the Proceedings at the Twenty-seventh Annual Congress held at Southampton, 1922. Edited by Edward A. Martin. Pp. ixiii+73. (London: 285 Holmestdale Road, S.E.25.) 5s. net.

## Diary of Societies.

## SATURDAY, NOVEMBER 18.

BRITISH MYCOLOGICAL SOCIETY (In Botany Department, University College), at 11. Prof. A. Castellani: Mycology in Tropical Medicine.—Miss G. Gilchrist: Bark Canker Disease of Apple (*Mycosporium carthagenum*).—Miss E. S. Moore: The Physiology of *Fusarium corundini*.—R. J. Tabor: A new fungal disease of Cacao and Coffee.—Dr. M. C. Rayner: The Mycorrhizal Fungus in relation to *Calluna* Cuttings.

## MONDAY, NOVEMBER 20.

INSTITUTE OF ACTUARIES (at Royal Society of Arts), at 5.—W. P. Phelps: Presidential Inaugural Address.  
ROYAL GEOGRAPHICAL SOCIETY (at Lowther Lodge, Kensington Gore), at 5.—Capt. G. I. Finch: The Equipment for High Climbing.  
INSTITUTION OF ELECTRICAL ENGINEERS (Inaugural Meeting), at 7.—F. J. Pearce, and others: Discussion on Electric Light Wiring.  
INSTITUTION OF MECHANICAL ENGINEERS (Graduates' Section), at 7.—H. R. Hockley: Works Management.  
ROYAL INSTITUTE OF BRITISH ARCHITECTS, at 8.—L. M. Tye: Illuminating Engineering in relation to Architecture.  
INSTITUTE OF BREWING, at 8.—W. A. Riley: Elimination of Waste.  
CHEMICAL INDUSTRY CLUB (at 2 Whitehall Club), at 8.—O. F. C. Bromfield: The Merchant Traders' View on Government Control of Trade in connexion with the Safeguarding of Industries Act and the Dyestuffs (Import Regulation) Act.

## TUESDAY, NOVEMBER 21.

ROYAL GEOGRAPHICAL SOCIETY AND THE ALPINE CLUB (at Central Hall, Westminster), at 3.—Capt. J. B. L. Noel: First Exhibition of the Mount Everest Expedition Kinetograph Film.  
ROYAL SOCIETY OF MEDICINE, at 5.—General Meeting.  
ROYAL STATISTICAL SOCIETY (at Royal Society of Arts), at 5.15.—Lord Emmott: The Relations of Capital and Labour. (Inaugural Address).  
ZOOLOGICAL SOCIETY OF LONDON, at 5.30.—The Secretary: Report on the Additions to the Society's Menagerie during the month of October, 1922.—I. G. S. Montagu: A further Collection of Mammals from the Imber Hebrides.—F. R. Wells: The Morphology and Development of the Chondrocranium of the larval *Clupea harengus*.—R. I. Pocock: The External Characters of the Beaver (*Castor*) and some squirrels (*Sciuridae*).—A. Loveridge: Notes on East African Birds (chiefly nesting-habits and stomach-contents) collected 1915–1919.—E. A. Stenisp: Notes on certain Crosspepterygians.—Dr. E. Ghosh: The Animal of *Scaphala* Benson, with the Description of a new Species of *Scaphala*.—J. H. Lloyd and Edith M. Sheppard: A Contribution to the Anatomy of a Hammerhead-shark (*Ziphenodon mollis*).—R. H. Mehra: Two new Indian Species of the little-known Genus *Autobius* (Bretschner), aquatic Oligochaeta belonging to the Family Tubificidae.—Dr. J. Stephenson: The Oligochaeta of the Oxford University Spitzbergen Expedition.—R. J. Ortlepp: The Nematode Genus *Phasmodora*, Kud.—G. M. Vevers: The Costode Parasites from Mammalian Hosts which died in the Gardens of the Zoological Society of London during the Years 1919–1921: with a Description of a new Species of *Cyrtolarcha*.

INSTITUTION OF CIVIL ENGINEERS, at 6.—E. O. Forster-Brown: Underground Waters in the Kent Coalfield, and their incidence in Mining Development.  
INSTITUTE OF MARINE ENGINEERS, INC., at 6.30.—G. J. Steinheil: The Evolution of the Nobel Diesel Engine (Part II).  
ROYAL PHOTOGRAPHIC SOCIETY OF GREAT BRITAIN, at 7.—A. L. Coburn: Astrological Portraiture.  
ROYAL ANTHROPOLOGICAL INSTITUTE, at 8.15.—Miss M. A. Murray: Recent Excavations in Malta.  
ROYAL GEOGRAPHICAL SOCIETY AND THE ALPINE CLUB (at Central Hall, Westminster), at 8.30.—[Captain J. B. Noel: First Exhibition of the Mount Everest Expedition Kinetograph Film.]  
ROYAL SOCIETY OF MEDICINE (Pathology Section), at 8.30.—Dr. G. L. V. de Wesslow: The Calcium and Phosphorus of the Blood in Nephritis.—Dr. C. E. Dukes: A New Fermentation Tube.—Dr. A. J. Easton, Dr. C. C. Okell, and Miss E. M. Baxter: The Serological Classification of *B. Diphtheriae*.

## WEDNESDAY, NOVEMBER 22.

ROYAL SOCIETY OF MEDICINE, at 5.—Prof. H. C. Jacobaeus: The Practical Importance of Thoracocopy, especially in the Pneumothorax treatment of Pulmonary Tuberculosis. (Occasional Lecture.)  
ROYAL METEOROLOGICAL SOCIETY, at 5.—Sir Napier Shaw: An account of the work of the Meteorological Section of the International Union of Geodesy and Geophysics during the meeting at Rome in

May, 1922.—A. H. R. Goldie: Circumstances determining the Distribution of Temperature in the Upper Air under conditions of High and Low Barometric Pressure.—Rev. J. Aigué: The Manilla Typhoon of May 23, 1922.  
GEOLOGICAL SOCIETY OF LONDON, at 5.30.—Prof. A. S. Eddington: The Borderland of Astronomy and Geology.  
ROYAL SOCIETY OF ARTS, at 8.—Jillie W. Smith: The Economy of Smoke Abatement.

## THURSDAY, NOVEMBER 23.

MEDICO-PSYCHOLOGICAL ASSOCIATION OF GREAT BRITAIN (at the Jethlem Royal Hospital), at 2.45.—Prof. G. M. Robertson: The Discovery of General Paralysis, from Haslam to Bayle.—Dr. E. W. Scripture: The Treatment of General Paralysis by Malaria and the Use of Speech Inscriptions for Early Diagnosis.  
ROYAL SOCIETY, at 5.—Prof. A. S. Eddington: The Characteristics of Cylindrical Journal Lubrication at High Values of the Eccentricity.—Prof. F. C. Thompson and E. Whitehead: On the Changes in Iron and Steel at Temperatures below 280° C.—Dr. J. H. Jeans: The Propagation of Earthquake Waves.—Prof. F. A. Lindemann and G. M. B. Dobson: A Theory of Meteors and the Density and Temperature of the Outer Atmosphere to which it leads.—C. F. Jenkin: The Fatigue Failure of Metals.—Dr. S. Brodetsky: The Line of Action of the Resultant Pressure in Discontinuous Fluid Motion.—Dr. H. A. Houston: An Investigation of the Cause of Vision of Forest Trees by the Rayleigh Test.  
CAMERA CLUB, at 8.15.—Dr. G. H. Rodman: The Story of the "Cuckoo Spit."

## FRIDAY, NOVEMBER 24.

MEDICAL OFFICERS OF SCHOOLS ASSOCIATION (at 11 Chandos Street, W.1), at 5.—Dr. A. R. Friel: The Ionisation Treatment of Otorrhoea.  
ROYAL SOCIETY OF MEDICINE (Study of Disease in Children Section), at 5.  
PHYSICAL SOCIETY OF LONDON (at Imperial College of Science and Technology), at 5.—E. G. Richardson: The Theory of the Singing Flame.—Prof. R. L. Jones: Vibration Galvanometers with Asymmetric Moving Systems.—Miss Alice Everett: Unit Surfaces.—P. Schleichowsky: Demonstration of some Practical Applications of the Gyroscope.  
INSTITUTION OF MECHANICAL ENGINEERS, at 6.—Adjourned discussion on paper by W. Reavey on Air Compressors.  
JUNIOR INSTITUTION OF ENGINEERS, at 7.30.—F. E. Murrell: Notes on Waterworks Plant in India.  
INSTITUTION OF PRODUCTION ENGINEERS (at Engineers' Club, Coventry Street, W.1), at 7.30.—G. Hey: Standardisation.  
ROYAL SOCIETY OF MEDICINE (Epidemiology and State Medicine Section), at 8.—Dr. F. M. Turner: A Statistical Study of the Age Incidence of Scarlet Fever.—Dr. J. Brownlee: A Note on the Relation between Rainfall and Scarlet Fever.  
ROYAL PHOTOGRAPHIC SOCIETY OF GREAT BRITAIN, at 8.—C. H. E. West: The Fascination of North Africa.

## SATURDAY, NOVEMBER 25.

ASSOCIATION OF SCIENCE TEACHERS AND THE ASSOCIATION OF UNIVERSITY WOMEN TEACHERS (at University College), at 11 and 2.30.—Joint Conference on the Teaching of Science in Schools and Colleges.

## PUBLIC LECTURES.

## SATURDAY, NOVEMBER 18.

HORNIMAN MUSEUM (Forest Hill), at 3.30.—A. D. Howell Smith: Textiles and their History.

## MONDAY, NOVEMBER 20.

ROYAL SANITARY INSTITUTE, at 4.—Dr. A. Balfour: The Sanitary Inspector in the Tropics.  
CITY OF LONDON Y.M.C.A. (186 Aldersgate Street), at 6.—General Sir W. B. Leishman: Bacteriology of Disease.

## TUESDAY, NOVEMBER 21.

ROYAL SANITARY INSTITUTE, at 4.—Lt.-Col. W. W. Clemens: Hookworm Disease and the Method of Controlling It. At 5.15.—Miss A. D. Muncester: Some Hygienic Aspects of Food and Food Preparation. II. The Hygiene of Food Preparation (Chadwick Lecture).

## WEDNESDAY, NOVEMBER 22.

ROYAL SANITARY INSTITUTE, at 4.—Prof. R. T. Leiper: Parasitic Worms and their Migrations.

## THURSDAY, NOVEMBER 23.

ROYAL SANITARY INSTITUTE, at 4.—Lt.-Col. H. J. Walton: Flies and Mosquitoes.  
UNIVERSITY COLLEGE, at 5.—Prof. H. R. Kenwood: The Pasteurisation of the Public Milk Supply.  
WESTFIELD COLLEGE (Hamstead), at 5.15.—Sir Oliver Lodge: Matter and Ether.

## FRIDAY, NOVEMBER 24.

ROYAL SANITARY INSTITUTE, at 4.—Dr. H. B. G. Newham: Malaria and other Diseases.  
UNIVERSITY COLLEGE, at 5.15.—Prof. J. E. G. de Montmorency: Law and the Humanities.  
BEDFORD COLLEGE FOR WOMEN, at 5.30.—M. L. W. Laistner: Ancient University Life.

## SATURDAY, NOVEMBER 25.

HORNIMAN MUSEUM (Forest Hill), at 3.30.—F. Balfour-Browne: British Water-beetles.



# NATURE

A WEEKLY ILLUSTRATED JOURNAL OF SCIENCE.

*"To the solid ground  
Of Nature trusts the mind which builds for aye."*—WORDSWORTH.

No. 2769, VOL. 110] SATURDAY, NOVEMBER 25, 1922 [PRICE ONE SHILLING

Registered as a Newspaper at the General Post Office.

[All Rights Reserved.]

## BALANCES & WEIGHTS

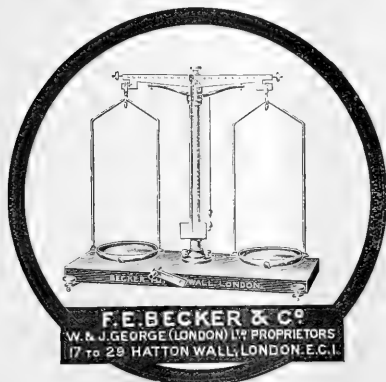

## REYNOLDS & BRANSON, Ltd.

Chemical and Scientific Instrument Makers to His Majesty's Government (Home and Overseas Dominions).  
LABORATORY FURNISHERS and MANUFACTURING CHEMISTS.

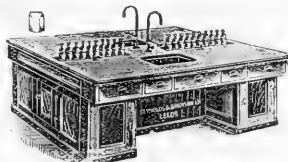

WORKS AND OTHER LABORATORIES equipped with Benches, Fume Chambers, Apparatus, Balances, Chemicals, etc.  
Designs and quotations submitted on application

BRITISH - MADE Glass, Porcelain, Nickel Ware, and Filter Papers.

Apparatus in Glass, Metal, or Wood made to customers' own Designs.

CATALOGUES POST FREE.

Enquiries for Technical Chemicals in quantity solicited.

14 COMMERCIAL STREET, LEEDS.



## SPECTROMETERS

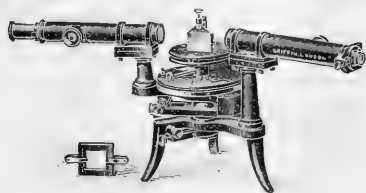

Particulars and Prices on application to—

JOHN J. GRIFFIN & SONS, LTD.  
Kemble Street, Kingsway,  
London, W.C.2.



## HAIR HYGROMETERS

for reading the percentage of moisture. Write for details of our latest patterns. For Laboratories, Cold Stores, Drying Chambers, etc.

NEGRETTI & ZAMBRA  
38, HOLBORN VIADUCT, E.C.1.  
LONDON.

## ROYAL SOCIETY.

## GOVERNMENT GRANT FOR SCIENTIFIC INVESTIGATIONS.

Applications for the year 1923 must be received at the Offices of the Royal Society not later than January 1 next, and must be made on printed forms to be obtained from the CLERK to the Government Grant Committee, Royal Society, Burlington House, London, W.1.

## CHEMICAL SOCIETY RESEARCH FUND.

A Meeting of the Research Fund Committee will be held in December next. Applications for Grants, to be made on forms which can be obtained from the ASSISTANT SECRETARY, Chemical Society, Burlington House, W.1, must be received on or before Friday, December 1, 1922.

All persons who received Grants in December 1921, or in December of any previous year, whose accounts have not been declared closed by the Council, are reminded that reports must be returned by Friday, December 1.

## CHRISTMAS SCIENCE COURSE IN SWITZERLAND.

DR. RUDOLF STEINER (Editor of standard editions of Goethe's scientific works), whose lectures at the recent Conference at Oxford opened up new fields of work in Education, will give a course of lectures on

## "THE GENESIS AND SUBSEQUENT DEVELOPMENT OF NATURAL SCIENCE IN THE HISTORY OF THE WORLD"

AT THE

GOETHEANUM, DORNACH, near BASLE,

December 24 to January 6.

For all particulars apply SECRETARY, Goetheanum Science Course, 46 Gloucester Place, London, W.1.

## BATTERSEA POLYTECHNIC,

LONDON, S.W.11.

Principal—ROBERT H. PICKARD, D.Sc., F.R.S.

Day and Evening Courses in Pure Chemistry (Inorganic and Organic) in preparation for University Degrees and A.I.C. and other professional examinations.

Special Technological Courses in Chemical Engineering, Oils, Fats and Waxes, Mineral Oils and Waxes, Toilet Soaps Manufacture, Lubricating Oils and Greases, Paper Making and Paper Testing, Paper Making (Engineering), Commercial Paper Work, Applied Bacteriology, Testing of Disinfectants, Analysis of Foods, Waters, Fertilisers and Feeding Stuffs, Microscopy of Food and Drugs, Flour Milling, etc.

The instruction is both theoretical and practical, fully equipped laboratories being provided.

## NATIONAL UNION OF SCIENTIFIC WORKERS.

25 VICTORIA STREET, WESTMINSTER, S.W.1.

The main object of the Union is to secure in the interests of national efficiency that all scientific workers are given the fullest opportunity of working up to the limit of their capacity in the service of the community.

There are now eighteen branches of the Union. They include those formed by:

- (i.) University Scientific Staffs and Research Workers and Scientific Staffs in other teaching institutions;
- (ii.) Government Scientific and Technical Staffs;
- (iii.) Scientific workers in Industry.

The General Secretary of the Union will be pleased to arrange for members of the Executive to address meetings of industrial, Government departmental, or university scientific workers, on the work of the Union.

A list of members and the Annual Report for the year 1920-21 will be sent on application to

THE GENERAL SECRETARY,

at the above address.

## CHELSEA POLYTECHNIC,

CHELSEA, S.W.3.

Day and Evening Courses in Science under Recognised Teachers of London University.

- I. **INDUSTRIAL CHEMISTRY DEPARTMENT.**  
Technical Courses in Analytical and Manufacturing Chemistry Pharmacy, Food and Drugs, A.I.C. Courses, Metallurgy, Assaying, Foundry Work, Research.
- II. **INDUSTRIAL PHYSICS DEPARTMENT.**  
Practical work in General Physics, Applications to Industries, Metrology, Calorimetry, Illumination, Acoustics, Electrical Measurement, Research.
- III. **BIOLOGICAL AND GEOLOGICAL DEPARTMENT.**  
Courses for B.Sc., etc., in Botany, Geology, Mineralogy, Zoology, Special Courses in Bio-chemistry, Bio-physics, Bacteriology, Physiology, Hygiene, Entomology, Plant Pathology. Course for Tropical Planters, Research.

SIDNEY SKINNER, M.A.,

Telephone: Kensington 890.

Principal.

## UNIVERSITY OF BRISTOL.

The UNIVERSITY invites applications for the CHAIR OF PHILOSOPHY, which will be vacant on July 31, 1923. Salary, £800 per annum.

Applications should be lodged, on or before February 3, 1923, with the REGISTRAR, from whom further particulars are obtainable.

## SWANSEA EDUCATION COMMITTEE.

## SWANSEA MUNICIPAL SECONDARY SCHOOL FOR GIRLS.

HEADMISTRESS—MISS E. F. PHIPPS, B.A.

WANTED, in January, an ASSISTANT SCIENCE MISTRESS. Candidates must be Graduates of a British University with qualifications in Physics.

Salary according to the Burnham Scale for Secondary Teachers.

Forms of application may be obtained from the undersigned.

T. J. REES, Director of Education.

Education Offices,  
Dynevor Place, Swansea.  
November 1922.

UNIVERSITY OF LONDON,  
KING'S COLLEGE.

The Delegacy require the services of an ASSISTANT LECTURER in PHYSICS; salary £300 per annum. The duties will commence in January 1923. Opportunities will be given for research work.

Applications, with two copies of not more than three recent testimonials, should be received not later than November 30, by the SECRETARY, King's College, Strand, W.C.2, from whom further particulars may be obtained.

## THE UNIVERSITY OF LEEDS.

## DEPARTMENT OF AGRICULTURE.

Applications are invited for the position of ASSISTANT LECTURER in AGRICULTURAL ZOOLOGY. Salary £250. Applications will be received up to November 30, 1922, and should be addressed to the REGISTRAR, The University, Leeds, from whom further particulars may be obtained.

## FOR SALE.

Jl. Soc. Chem. Industry, 1896-1911, Index 1896-1905, bound (cloth). The Analyst, 1898-1913, bound, 1914-22, unbound. Chem. Centralblatt, 1897-1912, 44 sep. vol. bound (cloth), Index 1897-1911 (3 vol.), bound (leather). Biochem. Centralblatt, vol. 1, 1903-vol. 15, 1915, Index 1-10, bound (leather). Zeitschr. f. Analyt. Chemie, vol. 37, 1898-vol. 52, 1913, Index 41-50, bound (cloth). Chemiker Zeitung, 1895-1909, bound (cloth). On view in London. Offers to Box 2532, c/o NATURE Office.

## SPENCER GREENHUGH BINOCULAR

Microscope, bought recently, a pair of objectives and eyepieces, rests, etc., in case, perfect, £21. LEITZ  $\frac{1}{2}$ " oil objective, 1.3 as new. SWIFT ditto, £5 each. POWELL & LELAND Portable Microscope, monocular and binocular achromatic condenser, many eyepieces, etc., in case, bargain £30. ZEISS achromatic condenser, £5.—HARDING, 77 Hannah Street, Porth, Glam.



SATURDAY, NOVEMBER 25, 1922.

## CONTENTS.

	PAGE
Cambridge and the Royal Commission . . . . .	689
The Study of Spectra . . . . .	690
Animal Venoms. By A. A. . . . .	691
Crime and Remedial Punishment . . . . .	692
Our Bookshelf . . . . .	694
Letters to the Editor:—	
Speculation concerning the Positive Electron.—Sir Oliver Lodge, F.R.S. . . . .	696
The Measurement of Intervals.—Prof. A. S. Eddington, F.R.S.; E. Cunningham . . . . .	697
The Time-Triangle and Time-Triad in Special Relativity.—R. A. P. Rogers . . . . .	698
Space-Time Geodesics.—Prof. H. T. H. Piaggio . . . . .	699
The Dictionary of Applied Physics.—Sir R. T. Glazebrook, K.C.B., F.R.S. . . . .	699
Action of Cutting Tools.—Prof. E. G. Coker, F.R.S. . . . .	700
A New Worship?—Prof. Henry E. Armstrong, F.R.S. . . . .	700
The Spectrum of Neutral Helium.—Prof. C. V. Raman . . . . .	700
Water Snails and Liver Flukes.—Dr. Monica Taylor A Mutation of the Columbine. (Illustrated).—Prof. T. D. A. Cockerell and Dorothy Young . . . . .	701
The Atoms of Matter; their Size, Number, and Construction. (Illustrated.) By Dr. F. W. Aston, F.R.S. . . . .	702
The Herring Fishery and its Fluctuations. By B. Storow . . . . .	705
The Nebraska Tooth. By W. P. Pycraft . . . . .	707
Obituary:—	
Mrs. A. D. Waller . . . . .	708
Lady Herdman . . . . .	708
Current Topics and Events . . . . .	709
Our Astronomical Column . . . . .	712
Research Items . . . . .	713
The International Geological Congress of 1922. By J. W. E. . . . .	715
Education, Research, and Invention . . . . .	715
The Life History of the Eel. By J. J. . . . .	716
The Harrison Memorial. (Illustrated). By C. R. Y. . . . .	717
Long Distance Telephony . . . . .	718
Low Temperature Carbonisation. By Prof. John W. Cobb . . . . .	718
Expedition to Chinese Tibet . . . . .	719
University and Educational Intelligence . . . . .	720
Calendar of Industrial Pioneers . . . . .	721
Societies and Academies . . . . .	721
Official Publications Received . . . . .	724
Diary of Societies . . . . .	724

Editorial and Publishing Offices:

MACMILLAN &amp; CO., LTD.,

ST. MARTIN'S STREET, LONDON, W.C.2.

Advertisements and business letters should be  
addressed to the Publishers.

Editorial communications to the Editor.

Telegraphic Address: PHUSIS, LONDON.

Telephone Number: GERRARD 8830.

NO. 2769, VOL. 110]

## Cambridge and the Royal Commission.

IN the current number of the *Quarterly Review*, Sir William Ridgeway publishes a critical account of the recent report of the Royal Commission. As is not unexpected, he differs fundamentally from the Commissioners on certain points. First of all he opposes the principle of accepting State grants with, as he suggests, "the uncomfortable corollary of State control." He fears that this will be of the nature of "continuous administrative control" and that Cambridge will lose that liberty of spirit and initiative which have built up her present strong position in the scientific and educational world. Many of those who do not share Sir William Ridgeway's fears will agree with him that much trouble to all concerned will be saved, and some freedom from Parliamentary pin-pricks from cranks or extremists will be secured, if the grant which the Commissioners recommend can be charged on the Consolidated Fund.

The second main criticism is that the Board of Studies and Research, the body charged with the control of the studies of the University, is placed too directly under the Council, the administrative body of the University. As the electorate which chooses both bodies is the same, any serious difficulties that may arise through differences of opinion between the administrative and teaching members of the University would always be capable of early adjustment. As the teachers are in the majority, the side that would presumably suffer in any such conflict as Sir William Ridgeway foreshadows would be the administrative side. On the ground which he has chosen it is doubtful whether the criticism can be maintained. On other grounds there is a great deal to be said against the majority of so important a body in the University as the Board of Studies being nominated by the Council.

The main attack of Sir William Ridgeway is, however, levelled against the proposals of the Commission to reduce the powers of the Senate, the non-resident graduates, and to give them no longer the final say in all serious matters of University policy. In his criticism of detail Sir William Ridgeway is not happy. When he says "The Cambridge Commissioners know perfectly well that it would not be easy to get fifty signatures to any appeal within a week," the obvious answer is that Sir William Ridgeway knows perfectly well that in any issue of importance where an appeal to the Senate is likely, fifty signatures could be collected in the Senate House from the defeated minority at the conclusion of the poll.

On the general question whether the ultimate control should lie with the Senate or with the House of Residents, there is naturally much divergence of

opinion. Sir William Ridgeway repeats an old challenge to the supporters of the House of Residents to cite a case where the Senate has outvoted the local body. There may be only one case, the recent compromise on the admission of women to the University. But the charge against the Senate's vote is that, as is perhaps only too natural with the older members of the University, the Senate's vote is consistently and steadily against change—or, if an alternative is presented, for the least possible change offered to its choice. Its control is capricious in so far as its intervention is made at the capricious decision of a body of resident conservatives who, through the Senate, wield a wholly disproportionate power on matters vitally affecting the well-being of the University.

### The Study of Spectra.

*The Physical Society of London. Report on Series in Line Spectra.* By Prof. A. Fowler. Pp. vii + 183 + 5 plates. (London: The Fleetway Press, Ltd., 1922.) 12s. 6d.

*A Treatise on the Analysis of Spectra: Based on an Essay to which the Adams Prize was awarded in 1921.* By Prof. W. M. Hicks. Pp. viii + 326. (Cambridge: At the University Press, 1922.) 35s. net.

OF the two works now under notice, the first, by Prof. Fowler, is the third of the series of reports published by the Physical Society, its predecessors being those by Dr. Jeans on Radiation, and by Prof. Eddington on the Relativity theory. These set a very high standard, but the present work worthily maintains it, and we are glad, at the outset, to offer congratulations to the Physical Society on the continued service which it is rendering to science by their publication.

The choice of subjects for these reports has been singularly happy. The first two dealt with the matters which, at the time, were most prominently in course of development. This third report has at least an equal claim to attention on a somewhat different ground. The remaining problem which is most outstanding, both for the physicist and chemist, and indeed for every scientific man, is that of the structure of the atom. Clues towards its comprehension are provided on every hand by the practical and statistical workers; but they never become final in their importance. After Balmer formulated his well-known expression for the hydrogen spectrum as an orderly arrangement, at least eight model atoms, constructed on entirely different principles, have been used to deduce it theoretically. Its simplicity alone condemns it as a decisive factor in our knowledge, and

the practical worker, who shows us that, even artificially, elements can be broken up, takes us no further towards the formulation of the fundamental dynamical principles, all-embracing in their scope, which determine the behaviour and structure of an individual atom, once and for all, when we know the charge on its nucleus and the number of electrons pursuing their orbits.

The study of spectra must provide the final test of any atomic theory. Spectra can be measured with an accuracy far transcending that obtained in any other phenomena which bring us into touch with an individual atom, and spectra have never been measured systematically by any worker with the general accuracy obtained by the author of the present report. A remarkable part of the work described in this report is due to Prof. Fowler himself, not only in respect of the accuracy of measurement, but even more as regards the elucidation of the nature of the spectra and the conditions which regulate their appearance in the laboratory or in celestial bodies.

For many years spectroscopists have been at a great disadvantage. All the literature of their subject has been scattered, and a general compendium, written by one in the forefront of progress, has been perhaps the most urgent need of the physicist whose aim is the direct determination of the laws governing the motions in an atom of any element more complex than hydrogen. In the last resort, the test of a theory of any chemical atom is that its possible radiations can be determined, by pure mathematical analysis, as specific numbers with a degree of accuracy of at least one part in 10,000, which shall preclude any possible fortuitous coincidence. In certain cases this appears to have been done. Nicholson's investigation of the coronal spectrum, and Bohr's theory of the hydrogen and charged-helium spectrum, together with Wilson's and Sommerfeld's remarkable determination of the appropriate generalisation for elliptic paths of the electrons, appear, for example, to meet this necessity. But all such investigations are preliminary only, and nothing is certain till a more complex spectrum is so elucidated.

The material for such a generalised treatment of the quantum theory is presented in full detail by Prof. Fowler. The treatment is very lucid and this work will completely replace the more usual but out-of-date accounts, which the spectroscopist now has in his library. The present work may be expected to mark a definite epoch in the history of atomic theory as well as of spectra in their more limited scope.

The author, like Prof. Hicks in the other work under notice, is not concerned with particular theories. In a certain sense, however, Prof. Hicks is so concerned,

for he has asserted that a series spectrum does not follow a strict mathematical formula, but deviates from a "mean" formula in a manner expressible in terms of integral multiples of the "oun." These integral multiples are curious, and, without any wish to cast doubt upon the validity of the conception, perhaps a reader may be allowed to be amused when he learns that a line in a spectrum series, which has the power of deviating from its proper position by a specific number of ouns, should choose such numbers as 19, 59, and so on, rather than anything more simple, and seem to show preference for a large prime number.

We hope that this remark will not be interpreted as a severe criticism of Prof. Hicks, but it is one which every reader must make. The amount of computation which lies behind the results given by Prof. Hicks is stupendous, and it is quite impossible for the most hostile critic to deny that a substantial proportion of his series arrangements must be founded upon physical reality. At the same time, very serious difficulties will arise, in many cases, in the mind of a practical spectroscopist. There are undoubted instances in which Prof. Hicks's arrangement drives a definite spark-line into an arrangement of an arc-series. Such difficulties are not numerous enough to invalidate the author's point of view, which is at least as well fortified as that of any author who has claimed to give a *definite* formula for a spectrum series.

It is still possible to hold the position that all suggested formulæ for spectrum series are not more than empirical, and that their effectiveness is due solely to greater mathematical convergency and not to a closer correspondence with the "true" formula to which a physical theory should lead. Prof. Hicks rejects the possibility of this "true" formula, in favour of a divergence of all the lines, by arbitrary multiples of the "oun," from a "mean true" formula—a position which it is difficult for the theoretical physicist to accept. But he has done much to justify his belief, and his work renders very great service towards the orderly arrangement of series.

The volume is very difficult to read, for the author continues his practice of giving only the *difference* between the observed and calculated position of any line. This sometimes involves a long calculation before the line discussed can be identified. A recurrence of this trouble several times in rapid succession creates a feeling of hopelessness. But perhaps the size of the book would have been doubled if the author had attempted to relieve the reader.

Prof. Hicks's work is a monumental treatise on the arrangement of spectra in series, and is at least an indispensable addition to the library of any spectroscopist. The two works together place this subject on

an entirely new footing, and the physicist, who hitherto has obtained his knowledge of spectra from a scattered series of papers, now has a real opportunity to assimilate all the main points, and to co-ordinate the knowledge of atomic structure so derived with that obtained from more familiar but less precise data.

### Animal Venoms.

*Animaux venimeux et venins.* Par Dr. Marie Phisalix. Tome Premier. Pp. xxvi + 656 + iv pls. Tome Second. Pp. xii + 864 + xiii pls. (Paris: Masson et Cie, 1922.) 120 francs net.

TO most of us the term "venomous animal" suggests—a snake, a wasp, a spider, a scorpion, a centipede—perhaps also a toad, a fish or two, or a jelly-fish. Readers of this book, however, will learn that venomous animals are to be met with freely in all the phyla of the animal kingdom, except such sequestered or unobtrusive groups as Tunicata, Polyzoa, Brachiopoda, and sponges—although even the harmless necessary sponge in its native haunts may consort with a vicious sea-anemone.

The immunity to notoriety possessed by a diversity of venomous creatures is due partly to the fact that the subject has never, before the publication of these volumes, been treated as a connected and comprehensive story; and perhaps in even larger measure to the circumstance that we are apt to think of stings and fangs and spines as necessary attributes of venomous creatures, and to forget that besides toads there are plenty of venomous animals unprovided with any special and obvious weapons for discharging their venom.

In these two large volumes pretty well all that is known about venomous animals of all kinds has, at last, been collected and systematically arranged—and by authors who, during the course of many years of exact study, have themselves made many fresh contributions to this particular store of knowledge. Thus, although the work may be called a compilation, and may be accorded all the merit of novelty as such, it must also be invested with much of the higher excellence of an original creation.

A preface by the lamented Laveran states that the treatise was projected many years ago when Mme. Phisalix was collaborating with her husband, Dr. Cæsar Phisalix (who in 1894 was awarded, conjointly with Dr. C. Bertrand, the Montyon prize of the Academy of Sciences "for the general results of their work on venoms, forming the scientific basis of anti-venomous therapy"), and that after her husband's premature death in 1906 it was continued and completed by herself.

From the introductory chapter we understand that the term animal-venom is taken in its widest sense, to include not only tangible secretions, like snake-venoms, which are elaborated and discharged, with intent to do hurt, by special apparatus, but also toxins like those attributed to pathogenic Protozoa, of which the existence is inferred rather than conclusively demonstrated. In this broad outlook the obvious function of an animal-venom as a gross means of defence or attack, becomes a very special and striking development of a general cellular disposition to defence or retaliation; and from this point of view the manufacture of toxin is to be seen as a primitive function of wide prevalence in the animal kingdom, and the manifestly venomous animals in each zoological group are to be regarded as a sort of powerful or privileged caste. To the cynic it may perhaps be some consolation to reflect that in Nature's livery we are all more or less toxic—that one touch of toxin makes the whole world kin.

This theory of a general prevalence of animal toxins and of their function, like other secretions, in influencing the nutrition of the individual, the influence in this case being to stimulate cellular resistance and ultimately to provoke natural immunity to poisons in general, is elaborated in a final chapter on the functions and uses of venoms, where also there are some interesting remarks on the therapeutic employment of animal-venoms in ancient and modern times, and some justifiable anticipations that snake-venoms may find a further place in the scheme of rational therapeutics. The part played by their venom in the digestive processes of snakes appears to be disregarded.

Outside these most interesting initial and final chapters are to be found about 1500 pages of considered facts set down in zoological and historical perspective, the general tone being academic, though accidents due to venoms and their treatment are not disregarded. Each zoological group is treated separately, in the anatomical details of the specific venom apparatus, in the physiological properties and pathological effects of the specific venoms, in historical and bibliographical particulars, and also as much as possible from the point of view and bearings of natural and acquired immunity. There is perhaps rather too much admixture of pure zoology of a kind that can scarcely be countenanced as relevant; e.g. the 116 pages given to taxonomy and distribution of snakes, over and above 125 pages devoted to pertinent anatomical description, is perhaps an extreme example of this superfluity.

As might be expected, the chapters on venomous reptiles and amphibia are the strongest, and those on groups, such as parasitic worms, in which the sources of the toxins are to some extent a matter of speculation, are the weakest. Naturally also in the chapters on

the invertebrate groups, those on scorpions and certain Hymenoptera contain the most original matter. Considerable space is allotted to spiders and the effects of their venom—enough to correct any lingering incredulity as to the serious possibilities of spider bite. Ticks, however, are dismissed in 18 lines, and Annelida and parasitic Crustacea are not noticed at all. Fishes are dealt with very fully in three categories, according as they are venomous in spine or tooth, or persistently or periodically toxic as food, or possess notably toxic blood. The amphibia, on the venoms of which Mme. Phisalix is a particular authority, are very thoroughly considered. In dealing with the venomous lizard, *Heloderma*, the author also draws freely on her own researches in the laboratory, as well as from vivid personal experience of the effects of its bite. Venomous snakes occupy more than two-fifths of the entire treatise; among them are included not only the vipers and sea-snakes and elapine and opisthoglyph colubrids, but also a number of aglyph colubrids, *Boiidae*, *Ilysiidae*, *Uropeltidae*, and *Amblycephalidae*, which possess a poison gland, though they are destitute of grooved fangs for injecting the secretion. The text is illustrated throughout by figures, and there are some coloured plates that reach perfection.

Of the book as a whole it is not enough to say that it represents a perfectly amazing amount of devoted labour in a fascinating field, or that it is the most complete and comprehensive treatise in existence on the subject of venomous animals. It is something more than this; and from the touching circumstances of its inception and the motives that helped to sustain its progress, as recorded in the preface by Laveran, one may be permitted to think that its accomplishment might, without, in this case, any taint of vanity, have finished with the proud conclusion *Exegi monumentum*.

A. A.

### Crime and Remedial Punishment.

*Penal Discipline.* By Mary Gordon. Pp. xiii + 238. (London : G. Routledge and Sons, Ltd.; New York : E. P. Dutton and Co., 1922.) 7s. 6d. net.

CRIME and criminals are subjects in which most of us are interested to a greater or less degree. The causes of crime, the development of an accidental into a confirmed criminal, and his treatment and mode of life in prison are things we like to read about, and some of us ponder over them. How far ameliorated conditions improve, or to what extent harder conditions deter, the prisoner are questions frequently discussed by sociologists and by the general public. Much has been written by theorists and idealists; others with practical experience as officials or prisoners have given

their views, frequently at considerable length, and all sorts of reasons and theories as to the classification, reformation, segregation, and even extinction of offenders have been promulgated.

It is now generally accepted that there is no so-called "criminal diathesis," no specially fore-ordained, criminally disposed individuality. The theory of crime as a form of conduct, so ably argued by the late Dr. Mercier, is generally accepted. We are all potential criminals, some more some less, and our tendencies to different forms of law-breaking are of different potentialities. According to our mental constitutions, physical circumstances, environmental temptations, and emotional control, are our powers of resistance to deviation from the normal, in our domestic and civil life. Society in self-defence has laid down a code of conduct for us founded on custom, morality, and religion, this code being designated as the "law." It is enforced by what are called punishments, and according to the gravity of the offence against these laws, these punishments vary, from a small monetary fine through varying terms of seclusion in state institutions, up to the extreme penalty, the death sentence. It is in these institutions—prisons—that deterrent and reformatory influences are brought to bear on the offender—penal discipline—with the object of preventing further offences by him or her against the law.

It is to the question of penal discipline that Dr. Gordon applies herself in the work under notice. Her experience as Lady Inspector of Prisons for a period of thirteen years has enabled her to form her own opinion on the matter, and, although her knowledge is solely that of the female offender, yet in her generalisations she has no hesitation in including the other sex. The book is well written and interesting to read, and it gives pen-pictures of several types of female, well known to any one who has come in personal contact with offenders of this sex. She discusses with ready pen and fluent language, inebriety, prostitution, venereal disease, tattooing, and the physical and mental characteristics of various offenders. The different penal institutions, local and convict prisons, and preventive detention and Borstal institutions are all described, and are all, without exception, condemned. She has no good thing to say for any of them. They must all be "scrapped." They are not deterrent, and they do not reform. The reforms which have gradually been taking place during the past forty years and are still being effected in our prison treatment and discipline appear to her useless and unavailing. Those who have watched these reforms and seen their benefits in the course of their daily life during that period may hold different opinions as to their effect, but Dr. Gordon will have none of it.

Dr. Gordon's remedial and substitutional measures do not appear so definite as is her condemnation of the present prison system. Teaching of trades and agricultural and horticultural employment, which she recommends, are now in vogue in convict prisons, Borstal and preventive institutions, and in several of the larger local prisons. It will take some time to educate the British public sufficiently to allow prisoners to conduct their private business from their place of detention. If so, we may find some of our erring financiers who are now in seclusion using Wormwood Scrubs or Parkhurst as business addresses from which to launch their schemes. The violent British convict will, we fear, not be awed into quietude by cells of match-board lining, nor will the absence of lock and key and brick and mortar walls be so effective in detaining him as our author appears to think; nor will the permission to have his own medical attendant brought daily to his sick-bed be probably so beneficial to him as to change his whole mental, moral, and physical nature. Psycho-analysis may or may not become a beneficial instrument in this respect. Many of her schemes may be regarded as impracticable and Utopian, but on one point Dr. Gordon lays marked emphasis, and here we are wholly with her. Heretofore the practice has been to try the prisoner for the offence and to make the punishment fit the crime. The punishment, on the other hand, should fit the criminal. Laws are based on the assumption that the breakers of them are all equally responsible, if sane. If not sane there are other ways of dealing with them. But apart from insanity the degree of responsibility in different persons cannot be considered equal by any one who has had the care and observation of the inmates of prisons. Their mental outfit is of varying quality, and their fitness to carry out the duties of ordinary citizens, though theoretically in the eye of the law the same, is found practically in many cases to be quite different. That the retaliatory idea of punishment, *lex talionis*, (though generally supposed to be a relic of barbarism) has not yet been buried was clearly demonstrated in a recent case where Press and public joined in an outcry against the Home Secretary.

The personal equation and mental equipment of individual offenders is a point which should, in the future, be more clearly defined and inquired into before sentence, and this especially in the case of the young offender. The Mental Deficiency Act (1913) made it possible when congenital causes were demonstrable to send these cases to suitable institutions, but there are many now in prison who are clear cases for permanent detention, though the defect is not clearly traceable to congenitalism, and therefore they cannot be certified under this Act.

That the present system of prison administration has elasticity and progressiveness is shown by the policy towards these offenders at Birmingham and other centres, where special arrangements have been made for the observation and examination of any prisoner whose mental capacity seems impaired, by trained and efficient medical men. Here, after a period of detention on remand, where the offender is carefully observed, his previous history ascertained, and his psychology investigated, on the report or evidence of the medical observer, sympathetic justices dispose of the case in a manner which is most suitable to the circumstances of the individual, and not on the old stereotyped method of sentence following crime. In regard to Borstal institutions also, which at one time held out so much promise, the study of the individual offender is all-essential, and, though this is now done by the officials responsible, it is a matter of great doubt whether it can be carried out at all efficiently in a place where some 400 or 500 youthful offenders are congregated.

Dr. Gordon's book generally is well worthy of perusal, although we cannot accept all her conclusions or remedial methods on the subject of crime and criminals.

#### Our Bookshelf.

- (1) *Microbiology*. Edited by Prof. C. E. Marshall. Third edition revised and enlarged. Pp. xxviii+1043+1 plate. (London: J. and A. Churchill, 1921.) 21s. net.
- (2) *Laboratory Manual in General Microbiology*. Prepared by the Laboratory of Bacteriology and Hygiene, Michigan Agricultural College. Second edition. Pp. xxii+472+1 chart. (New York: J. Wiley and Sons, Inc.; London: Chapman and Hall, Ltd., 1921.) 21s. net.
- (3) *Die Anaphylaxie*. By Prof. Ch. Richet. Autorisierte Übersetzung von Dr. med. J. Negrin y López. Pp. iv+221. (Leipzig: Akademische Verlagsgesellschaft m.b.H., 1920.) n.p.
- (4) *A Treatise on the Transformation of the Intestinal Flora, with Special Reference to the Implantation of Bacillus Acidophilus*. By Prof. L. F. Rettger and H. A. Cheplin. Pp. vii+135+viii plates. (New Haven: Yale University Press; London: Oxford University Press, 1921.) 12s. 6d. net.
- (5) *Diagnosis of Protozoa and Worms Parasitic in Man*. By Prof. R. W. Hegner and Prof. W. W. Cort. Pp. 72. (Baltimore, Maryland: The Johns Hopkins University, School of Hygiene and Public Health, 1921.) n.p.

(1) PROF. MARSHALL'S volume is a text-book of general and applied microbiology. The morphology, cultivation, and physiology of micro-organisms are first dealt with, and an excellent account of these subjects is given. If any chapter were to be selected for special commendation, we should choose Chapter II., partly perhaps, because of its novelty in a work of this kind, in which the physical forces involved in biological

activities are described. An admirable summary is here given of such subjects as ionisation and dissociation, surface tension, adsorption, diffusion, and osmosis, colloids, and crystalloids—all of which are of fundamental importance for the understanding of biological activity. The second half of the book is devoted to applied microbiology, and accounts are given of micro-organisms in relation to air, water and soil, milk and foods, fermentations and disease, including the microbial diseases of plants and insects as well as those of man and animals. Twenty-five specialists in their various subjects contribute to the making of the book, and Prof. Marshall has edited and co-ordinated the whole. We know of no other book which in so limited a space gives such an excellent account, general and special, of micro-organisms in all their aspects. The text contains numerous illustrations.

(2) The second book on our list deals with micro-organisms from the practical laboratory standpoint. All the procedures employed for the study of micro-organisms are adequately described, and a series of class exercises for the study of organisms is detailed. The book forms a valuable practical laboratory manual, particularly useful for the teacher.

(3) Prof. Richet's book on the difficult subject of anaphylaxis is well known, and the volume before us is a translation from the French. The phenomena of the condition are fully described, the hypotheses of its causation are detailed, and a considerable bibliography is appended.

(4) The account of work accomplished in the Sheffield Laboratory of Bacteriology, Yale University, constitutes a valuable monograph, and will be indispensable to all those working on the microbial flora of the intestinal canal. An excellent historical review of the subject is given in the opening pages, a copious bibliography is appended, and the technique employed by the authors is described. The theme investigated is the transformation and simplification of the ordinary mixed intestinal bacterial flora through the diet, in conjunction with the oral administration of cultures of bacteria. This was claimed by Metchnikoff to be possible by the administration of milk soured with the *Bacillus bulgaricus*; but the authors state they invariably failed to accomplish this. By the use, however, of *Bacillus acidophilus* in place of *B. bulgaricus*, the required transformation seemed to be attained.

(5) Profs. Hegner and Cort have produced a useful little book which gives a brief, and on the whole accurate, account of the commoner protozoan and helminthic parasites of man so far as is required for diagnostic purposes; in this respect the several illustrations are a useful adjunct. It is just the book for the clinical laboratory and the medical practitioner.

R. T. HEWLETT.

*Insect Pests of the Horticulturalist: Their Nature and Control*. By K. M. Smith and J. C. M. Gardner. Vol. 1: *Onion, Carrot, and Celery Flies*. Pp. vi+76+plates. (London: Benn Brothers, Ltd., 1922.) 7s. 6d. net.

THE three pests described in this work are among the most serious enemies with which the commercial grower has to contend. Unfortunately, no really adequate measures for controlling any one of them have so far been discovered. The celery-fly, in its



larval stage, mines the leaves of both celery and parsnip. Owing to the concealed mode of life pursued during this period of its development, the insect is exceedingly difficult to kill by means of any feasible insecticide. Mr. J. C. M. Gardner, who is responsible for the section on the celery-fly, suggests the use of a spray containing chlororthocresol as a deterrent preventing the insect from egg-laying on the plant. He also suggests that a certain number of plants (presumably he means those of the parsnip) should be left in the ground to continue growth for a second year. Plants thus left were found, in a private garden, to be heavily infested, while neighbouring seedlings were only slightly attacked. It is, therefore, possible that the two-year-old plants might serve as a trap crop which, when heavily infested, could be pulled up and burnt. The idea, however, needs testing thoroughly on a practical scale.

Mr. K. M. Smith's account of the metamorphoses of the carrot-fly is a useful contribution, and the only complete description available. As regards control measures, he suggests the application of 1 part of green tar-oil to 99 parts of precipitated chalk, scattered between the rows as a deterrent to egg-laying. Since the eggs are deposited on the soil, and not on the plant, it will be seen that a thin application of this mixture may possibly also deter the young larvæ from reaching the plant, should it fail to act as a deterrent to egg-laying. Other repellent substances have also been tried by Mr. Smith, against both this insect and the onion-fly, with varying results. The book is suggestive, but it leaves the control of the pests with which it deals still in the experimental stage. It is clearly printed, and the illustrations are accurate.

*The Feeding of Dairy Cattle.* By Prof. A. C. McCandlish. Pp. xix+281. (New York: J. Wiley and Sons, Inc.; London: Chapman and Hall, Ltd., 1922.) 12s. 6d. net.

IN no branch of the art of feeding live-stock does practice tend to follow more closely the advance of nutritional knowledge than in the feeding of the milch-cow. The ease with which output can be measured, and the consequent facility of assessment of food requirements and economic returns, have rendered feasible a systematisation of this branch of feeding practice which is so far ahead of present possibilities in dealing with other classes of live-stock as to justify a specialised literature. The American student of agriculture has been well catered for in this respect in recent years, and the volume under review represents the latest addition to a list already long enough to warrant a critical attitude towards further additions. The justification of its issue does not rest on any appreciable novelty of material or method of presentation, but on the skilful manner in which the author has succeeded in giving in so few pages a thoroughly practical, lucid, and trustworthy survey of the subject, which cannot fail to be most useful to the practical man and practically minded agricultural student, for whom it is intended. The book is divided into five sections, the earlier sections being essentially scientific and leading up to the more detailed exposition of feeding practice, to which the last, and largest, section is devoted. The most recent developments in the science of nutrition receive adequate notice, and their

possible bearing upon practice is treated with commendable judgment and restraint. The book worthily fulfils the purpose for which it was intended, and may be cordially commended to progressive dairy-farmers and students in "farm institutes."

*Lehrbuch der anorganischen Chemie.* Von Prof. Dr. Karl A. Hofmann. Vierte Auflage. Pp. xx+751 +7 Tafeln. (Braunschweig: F. Vieweg und Sohn, 1922.) 300 marks; 24s.

THE fact that successive editions of Dr. Hofmann's "Inorganic Chemistry" have been issued in 1917, 1919, 1920, and 1921, is sufficient evidence of the popularity which it has achieved in German-speaking countries. The scope is very similar to that of English text-books of similar price, although it differs from these in containing a large amount of matter in small type and very few illustrations. Characteristic features are the postponement to the end of the book of a series of special subjects, which include explosives, co-ordination-compounds, the structure of crystals, radio-active substances, the structure of the atom, and the distribution of the elements. The theoretical introduction is therefore extremely brief, and the periodic classification of the elements is discussed in the body of the book without any reference to atomic numbers or isotopes. In view of the scantiness of the illustrations it is remarkable to find six figures given up to pictures of burettes, pipettes, and measuring flasks and cylinders in a section dealing with caustic potash. The seven plates which illustrate the flame-spectra of the elements, the line-spectra of the principal gases, and the absorption spectra of the rare earths are, however, excellently reproduced, and form a very pleasing appendix. It is, however, doubtful whether English readers will care to face the handicap of a foreign language in order to obtain instruction which they can assimilate with much greater ease from text-books in their own language.

*Radio for Everybody.* By A. C. Lescarboura. Edited by R. L. Smith-Rose. Pp. xii+308. (London: Methuen and Co., Ltd., 1922.) 7s. 6d. net.

MOST people are interested at present in radio-broadcasting, and there are many who are contemplating the purchase of a receiving-set. It will be of interest to them, therefore, to know how broadcasting has fared in America and the kind of programmes which are daily issued to the public. Specimen copies of these programmes are given. It appears that vocal and instrumental music, speeches and "talks," sermons and stories for children are the most popular items. The book contains an interesting chapter on the development and present position of radio-telephony in Great Britain. It is anticipated that radio-broadcasting will soon be as popular in this country as it is in America. We think, however, that the user of a receiving-set will find that on about one of every five days in this country receiving will be seriously interfered with by atmospherics. The rest of the book gives a popular but accurate account of the various kinds of radio-apparatus. There is no doubt that the mystery and fascination of the art of radio-communication is attracting many boys to take up applied electricity as a career.

### Letters to the Editor.

[The Editor does not hold himself responsible for opinions expressed by his correspondents. Neither can he undertake to return, or to correspond with the writers of, rejected manuscripts intended for this or any other part of NATURE. No notice is taken of anonymous communications.]

#### Speculation concerning the Positive Electron.

I WRITE hypothetically, and in an interrogative mood except that I scarcely expect a present answer, but it is simpler to state a hypothesis with preposterous dogmatism, in imitation of the unconscious manner of the crank.

According to Larmor's theory the positive and the negative electrons can only differ, or at least must chiefly differ, in one being the mirror-image of the other. One for example might be a concentrated locked right-handed screw-twist in the Ether, while the other would be a left-handed contortion of precisely the same kind, simultaneously and inevitably produced, and connected with its fellow by transferable lines of force. Both would incidentally have to involve also a residual strain or tension, proportional to the square of the twist and inversely as the distance from it.

Needless to say, no positive electron in this sense has yet been discovered. If they exist, why not? Because electrons of both kinds are so extremely mobile, and the forces between them so immense, that they instantly bind themselves together into a compact and exceedingly stable structure, consisting of some hundreds or thousands of each kind; the simplest and lightest of which composite structures we know as the proton or hydrogen nucleus. Short of that grouping, the compound units are either too fully neutralised to be perceived, or else too greedy of each other to exist separately. The proton, for the first time, allows a single electron to be free enough to revolve permanently round the close-packed group without being utterly absorbed and incorporated in its composition.

A number of protons can unite and form the nuclei of other atoms, and in this case several free electrons can remain incompletely assimilated, so as to form a satellite system characteristic of each different element. Such composite nuclei can be shattered by adequate means, but the single nuclei are very stable, and the proton itself has not yet been near disintegration; nor is it clear whether anything detectable could result from its fracture, especially if the fragments were electrically neutral.

But now comes a question, difficult to answer on the mirror-image hypothesis:—Why should only negative electrons occur in the satellite systems? Why should not some atoms have nuclei with a surplus of negative charge, and be attended by positive electrons?

Possibly an answer may be forthcoming from those who either now or hereafter understand the formation of an  $\alpha$ -particle, and why it has two positive—and always positive—charges; for it seems to form an essential intermediate ingredient in the building-up process.

But assuming that no answer is forthcoming; are we quite sure that no atoms are of the exceptional variety? Can such a variety exist? It seems a possibility just worthy of contemplation, unless experimental observation already absolutely negatives it. Photo-electric evidence is strong; the Zeeman effect appears conclusive. But is it final? It demonstrates clearly enough that the radiating particle has an electro-chemical equivalent of the

order  $10^7$ , and is therefore an electron of some kind, but is it conclusive about the sign in all cases? Perhaps it is: but there is no harm in reconsidering a conclusion occasionally, even if the already accepted answer turns out quite indubitable.

If all radiation is from the negative electron only, that curious fact would seem to point to some striking qualitative difference between the negative and the hypothetical positive electron: a difference which on Larmor's theory of the Ether is difficult to grant, though it may have to be granted. It is owing to this difficulty that there has arisen the otherwise attractive idea of a positive electron so intensely concentrated as to be about  $1/1800$ th of the linear dimension of the negative electron, and therefore to possess incomparably greater inertia. This may be the right way out of the difficulty, but it requires proof.

If, pending proof, we try to work with a mirror-image pair of electrons, can we anyhow account for the apparent fact that atoms have only negative satellites? Perhaps thus:—Consider a crowd of new-born electrons, both positive and negative. If, among the manifold chances of structural packing, something less than half of the atomic nuclei formed were of the kind with positive satellites, while the other approximate half were of the negative satellite variety, the two classes would speedily combine with a violence inappropriate to anything that can be called molecular combination. They would thereby form the tight-packed and stable nuclei of heavier atoms, until the complexity was great enough to result in instability. That may be how the heavier atoms were formed. If the packing took place by chance, there might be a small surplus of one variety in excess.

The combination of nuclei would only cease when they were protected by a screen of similar electrons; their sign might be + or might be - but could not be both. In other words the resulting atoms could not be of opposite varieties; the satellites of the surplus variety must be all of one sign, or the atoms would combine with each other and form a new substance. Thus we could get the outlying satellites of one sign, either in every case or in so vast a preponderance of cases that no exceptions are as yet manifest. In the nascent stages there might be a random distribution of the two varieties, in numbers nearly equal but not accurately equal, like the male and female of a population; then most of them would mate and constitute higher nuclei, while the variety which happened to be in the majority would remain as it was, and become conspicuous. The number mated might be a hundred times greater than the number of outstanding single ones and yet these last would be what we know as the atoms of the elements familiar to-day. It is plain that the number of protons embedded in the nuclei of all the atoms must be in excess of the number of atoms themselves. The atoms themselves represent the surplus, the excess kind that could find no partners. The number of protons embedded in atomic nuclei are  $\frac{(1+2+3+\dots+92)}{92}$  times the number of known atoms, say 46 times as numerous.

Some fallacy here: for the elements are not all equally plentiful. But the middle ones are on the whole the most plentiful, and the statement may pass as a rough approximation.

Directly a positive variety of atom gets loose, it will combine with the nearest negative variety accessible, and push it a step or two up the series. In that way heavier elements may still occasionally be born. The free life-time of the less plentiful variety would be too brief for ordinary detection;

but now that shattering of nuclei is possible, and now that rapid means of detection are feasible, there is something to look for. The formation of strange substances and unusual combinations may be expected, and the composite nature even of the proton may yet be demonstrated by the emission of something fractional of extreme instability. Does not the atomic bombardment of aluminium already yield particles of extra long range?

I make no apology for this surmise. Speculation as a temporary working hypothesis is sometimes suggestive of further experiment, and that is its sole justification. If the tendency of the discussion is to uphold the greater simplicity of the extra-small and extra-massive indivisible positive particle, well and good; but that would rather close the door on one line of experiment, and it is not well to abandon the mirror-image idea prematurely. The proton *may* be an indivisible ultimate unit; but that seems unlikely, and we have learnt not to negative the possibility of ascertainable structure lightly. It seems barely credible, now, that it was an indivisible ultimate unit that we used to regard the atom!

The hypothesis that a proton is built up of positive and negative but otherwise identical electrons may yield a hydrogen nucleus too bulky for the facts, and may otherwise have to be rejected, but the idea at least leaves the door open to the extraordinarily brilliant experimental physicists of to-day, and hence as long as possible may be tentatively and provisionally encouraged.

OLIVER LODGE.

Normanton, Lake, Salisbury.

#### The Measurement of Intervals.

I CANNOT resist Mr. Cunningham's invitation in his review of my Romanes Lecture (NATURE, Oct. 28, p. 568) to justify more precisely the transition from the picture of world-history as a tangle of world-lines to the scheme of intervals filling a continuum of space-time and demanding non-Euclidean geometry. "Prof. Eddington seems to contemplate as 'measurable' the intervals between pairs of points in this continuum which do not correspond to events in the history of any particle or electron in the material universe. But we wish to ask him how these intervals are in practice to be measured." Mr. Cunningham's point is that the picture which we have to dissect is the *actual* history of the world, and we are not allowed to alter it—to introduce measurements which never were made, or to introduce physically recognisable events at points where nothing actually happened. I accept this limitation. He admits, however, that all measurements that have ever been made are contained in the picture, and, I might add, all measurements that ever will be made. Thus we have a large number of measured intervals available for discussion; and I think that Mr. Cunningham, like myself, is convinced that the geometry which these measured intervals obey is not exactly Euclidean but is given correctly by Einstein. When once this geometry is determined we proceed to fill all space-time with *calculated* points and intervals; just as we ordinarily fill all space with calculated points and distances after first determining the geometry by means of a few distances actually measured and a few points actually perceptible. Only a small number of the calculated points and intervals correspond to events and measurements in the historical picture; but whenever there is a measured value it will agree with the calculated value.

As regards the status in physics of this scheme of

calculated points and intervals, it does not seem necessary to make any hypothesis; indeed, I scarcely know what hypothesis could be made about it. At the back of my mind I vaguely suppose that it is "closely descriptive" of an underlying relation-structure of the actual world; but whatever that means (if it means anything) it is too indefinite to use as an hypothesis. It is sufficient that we find it profitable to talk about this scheme. But at least its status is in no way inferior to the picture of tangled world-lines which Mr. Cunningham finds it convenient to start from. Material particles and events outside us are not directly observed: they are inferred from the fields (inertial and electromagnetic) which affect our bodies. But the field itself is not directly observed; it produces disturbances in the bundle of world-lines called a man. Inside the man the disturbance passes from field to matter and matter to field in endless cycle. Who shall say at what phase of the cycle it takes the final plunge into the realm of consciousness and actuality? Rightly or wrongly the method of science has always been to generalise from observation—to talk about a world which includes all that has been observed and a great deal which has not been observed. The astronomer does not make the *hypothesis* that the moon exists when nobody is observing it; but he finds it profitable to talk about a conceptual picture which contains a continuously existing moon. The scheme of calculated points and intervals (æther, or field) or of tangled world-lines (matter), or preferably both together, forms the world which the physicist finds it profitable to discuss; he can scarcely attribute more virtue than that to any world without wandering into metaphysics.

I must dissent entirely from Mr. Cunningham's statement that "any geometrical system whatever may be used for the purpose of attaching intervals." Clearly if a wrong geometrical system is used, the *measured* intervals will expose it by their disagreement. But Mr. Cunningham in this passage seems to use the word interval as though it had no fixed meaning and he could make it mean what he liked. If I recollect rightly, I originally introduced the name "interval," preferring it to the name "line-element" then current, which seemed unsuitable for a physical quantity as savouring too much of pure mathematics. I intended "interval" to mean a definite physical quantity—quite as definite as "energy," for example; and I desire to guard its meaning jealously. If the meaning of "energy" can be altered at pleasure, it is easy to upset the law of conservation of energy; and similarly by treating "interval" and "length" as words meaning nothing in particular, Mr. Cunningham has no difficulty in disposing of my contention that the world is not a Euclidean or flat world.

It will be seen that Mr. Cunningham and I are essentially in agreement that the merit of the Einstein scheme of intervals is its simplicity—"profitable to talk about"—rather than some kind of metaphysical significance. He regards it as selected from many other possible schemes because it gives a simple representation of the motion of particles and light-rays. That is a quite good enough reason for selecting it, but it must be borne in mind that it is not the historical reason for choosing it. The fact that it describes the exact motion of Mercury in a particularly simple way was only discovered after the whole scheme had been completed. The interest of Einstein's scheme is that there is, not one reason, but several reasons for selecting it. Not the least important of these reasons is that the scheme expresses the geometry of the world—in the sense in which the

word "geometry" is commonly understood, *e.g.* by the Board of Education.

One remark as to Newton and the apple, which I intended to typify a supported observer and a continuously falling observer, respectively. If, with Mr. Cunningham, we take the apple to typify an observer at first supported and afterwards free, the apple's view of things is appallingly complicated—compared even with Newton's. But that only the more emphasises the point that the natural simplicity of things may be distorted *ad libitum* by the process of fitting into an unsuitable space-time frame.

A. S. EDDINGTON.

Observatory, Cambridge,  
November 3.

I AM obliged to the Editor for giving me an opportunity to add a few words in comment upon Prof. Eddington's letter, and I do so in no captious spirit, but because it seems to me that in these very fundamental discussions it is of the utmost importance to clear away as many misunderstandings and difficulties as possible; to recognise that some divergences are merely consequences of viewing the same matter from different points of view, but that others may be due to looseness of thought on one side or the other; and I am glad to be able to recognise that most of the divergence of Prof. Eddington's exposition of the meaning of Einstein's theory from my own understanding of it is merely part of the difference between our natural ways of thinking. But two sentences in Prof. Eddington's letter do sum up my difficulty in regard to his exposition so clearly that I would like to direct attention to them.

"He admits, however, that all measurements that have ever been made are contained in the picture, and, I might add, all measurements that ever will be made. Thus we have a large number of measured intervals available for discussion."

In this sentence Prof. Eddington begs the whole question with which I ventured to end my review of his lecture. All measurements of length and all measurements of time that were ever made are, I agree, in the picture. But who ever measured this physical "interval"? What is the absolute scale of interval, and how is it applied? Again in Prof. Eddington's letter we read: "Clearly if a wrong geometrical system is used, the *measured* intervals will expose it by their disagreement." Unfortunately this is not at all clear to me, and I will try to explain why. So far as I can see, all actual physical measurements are records of observations of coincidences, *e.g.* of marks on a scale with marks on another body. That is to say, they correspond to intersections and concurrences of world lines of distinct physical elements. The significant feature of the four-dimensional picture of the universe is therefore merely the order of arrangement of such concurrences along the world lines of these physical entities. All else is of the nature of an arbitrarily adopted method of description of these orders of arrangement and is not contained in the picture itself. A geometrical system is an analytical means of describing the picture. The concurrences remain and their order is unaltered, no matter how we change our geometrical system. If I adopt a geometrical system other than that of Einstein, I may find the mathematics more complicated, but the actual observable facts recorded are the same—just as the fact of the meeting of the Great Northern, Great Eastern, Midland, and London and North-Western Railways in Cambridge station is quite independent of any particular brand of map

or time-table. Of course a map which denied this fact would be wrong—but the adoption of a different geometrical system of attaching what I must not call "interval" to the separateness of two events does not break up a concurrence. It is just because *actual measurements* will not be altered by any change of the geometrical system that I cannot agree with the sentence I have quoted.

E. CUNNINGHAM.

St. John's College, Cambridge,  
November 11.

### The Time-Triangle and Time-Triad in Special Relativity.

DR. ROBB directs attention in NATURE of October 28, p. 572, to the fact that there is much confusion of thought with regard to the stationary value of the integral  $\int ds$  in the special theory of relativity. When the path is purely temporal, as Dr. Robb was the first to point out, the integral is an absolute maximum, not a minimum. Prof. Eddington has also directed attention to this truth. The following view may be of interest. I give mainly the results, as the precise mathematical proof would occupy too much both of space and time.

Let A, B, C be the vertices (point-instants) of a *pure time-triangle* in the field of special relativity. Suppose C precedes A, and A precedes B in *proper time*; then it may be proved that C precedes B, *i.e.* proper time order is *transitive*. Then if  $\cosh C$  denotes the unit-scalar product of the vectors CA, CB, and if  $\alpha, \beta, \gamma$  denote the real and positive intervals BC, CA, AB, we have

$$\cosh C = \frac{\alpha^2 + \beta^2 - \gamma^2}{2\alpha\beta}.$$

It may be proved that the expression on the right-hand side is always positive and is greater than unity. Thus C may be regarded as the real invariant "*hyperbolic angle*" between the temporal vectors CA and CB. This angle has the same metrical value for all observers moving with uniform mutual relative velocities.

It can also be proved that  $a > \beta$ . Hence, since  $\cosh C > 1$ ,

$$a > \beta + \gamma.$$

That is, the *greatest side of a pure time-triangle is greater than the sum of the other two sides.*

It follows at once that the stationary value of the integral  $\int ds$ , where the path is purely temporal, is an absolute maximum.

There is thus a real hyperbolic angle between any two co-directional temporal vectors. The triangle ABC has two real "internal" hyperbolic angles (B and C), and one real "external" hyperbolic angle A'. Besides the above formula we have

$$\cosh A' = \frac{\alpha^2 - \beta^2 - \gamma^2}{2\beta\gamma}, \quad \cosh B = \frac{\gamma^2 + \alpha^2 - \beta^2}{2\gamma\alpha}.$$

Taking positive signs for intervals and angles, we have

$$\frac{\sinh A'}{\alpha} = \frac{\sinh B}{\beta} = \frac{\sinh C}{\gamma}$$

and  $\cosh (B+C) = \cosh A'$ .

Thus the *one real external angle of a time-triangle is equal to the sum of the two real internal angles.*

The hyperbolic angle between two co-directional temporal vectors has a perfectly definite physical meaning, if the physics of special relativity is sound. Let CA and CB be the time-axes used by two

observers X and Y. The spaces which they use are normal to these axes. Then if  $v$  be their mutual relative velocity,

$$v = \tanh C,$$

the velocity of light being unity.

It may be added that the relation  $B + C = A'$  is a particular case of the more general "triangle of relative velocities." Let OP, OQ, OR be a triad of co-directional non-coplanar temporal vectors (Dr. Robb's "inertia lines") cutting the "open hyper-sphere" (centre O)

$$u^2 - x^2 - y^2 - z^2 = 1$$

in point-instants P, Q, R, where  $u$  is the time co-ordinate. Let  $a, b, c$  be the geodesic arcs QR, RP, PQ within the hyper-sphere. These arcs are minima, not maxima; their elements in the limit are spatial in character, being normal to time-vectors; their hyperbolic tangents represent the mutual relative velocities of observers (X, Y, Z) who use OP, OQ, OR, or parallels thereto, as their time-axes. The Euclidean space used by X at any instant is parallel to the tangent space at P to the hyper-sphere, and from the point of view of X the directions of the relative velocities of Y and Z are the tangent-lines at P to the geodesic arcs PQ, PR. The angle between these directions is a circular angle (P), and the metrics of the geodesic triangle PQR are contained in the formula

$$\cosh a = \cosh b \cosh c - \sinh b \sinh c \cos P,$$

$$\frac{\sin P}{\sinh a} = \frac{\sin Q}{\sinh b} = \frac{\sin R}{\sinh c}.$$

When  $a, b, c$  are very small compared with the radius of the hyper-sphere the spaces of the observers are regarded as parallel, and we get the ordinary formula

$$a^2 = b^2 + c^2 - 2bc \cos P, \text{ etc.}$$

When OP, OQ, OR are coplanar we get the relation as before (with change of letters)

$$a = b + c.$$

The above remarkable formula for relative velocities was, I believe, first discovered by Dr. Robb, and is set forth by Dr. Weyl ("Space, Time, and Matter," § 2). I am not aware, however, that its direct connexion with the geodesic geometry of the open hyper-sphere has been explicitly noticed. R. A. P. ROGERS.

Trinity College, Dublin, October 31.

### Space-Time Geodesics.

IN NATURE of October 28, p. 572, Dr. Robb pointed out the incorrectness of asserting that the length of a "world-line" is a minimum between any two points of it. He gave an example in which the length was neither a minimum nor a maximum. The object of his letter, no doubt, was to remind some reckless relativists that they should be more careful in their language. But there is the danger that some may suppose that he was dealing with a real weakness in Einstein's theory. To dispel this idea we may recall a few well-known facts.

Treatises on the geometry of surfaces (in ordinary three-dimensional Euclidean space) define *geodesics* in various ways. Some say that a geodesic is the shortest line that can be drawn on the surface between its two extremities, and they use the calculus of variations to find its equations. This method is open to criticism. The researches of Weierstrass have shaken our faith in the infallibility of the results obtained by an uncritical use of the routine processes of that calculus. But whatever may be said against the process employed, the equations of a geodesic finally obtained agree with those obtained by more

trustworthy methods. For example, we may define a geodesic as a curve such that at every point the osculating plane is perpendicular to the tangent plane to the surface. From this definition we can easily obtain (cf. Eisenhart's "Differential Geometry," p. 204) equations which in the usual abbreviated notation of tensor calculus may be written

$$\frac{\partial^2 x^\sigma}{\partial s^2} + \left\{ \alpha\beta\sigma \right\} \frac{\partial x^\alpha}{\partial s} \frac{\partial x^\beta}{\partial s} = 0, \quad (\sigma = 1, 2).$$

Einstein's equations ("The Meaning of Relativity," p. 86) are the obvious generalisation of these and differ merely in that the suffixes range over the values 1, 2, 3, 4, instead of only 1, 2. His notation is slightly different from the form given above, which is due to Eddington.

These equations can be obtained by at least two other methods. Einstein uses a "parallel displacement" method due to Levi-Civita and Weyl. Eddington ("Report on the Relativity Theory of Gravitation," p. 48) shows that the equations are satisfied (or not) independently of the choice of co-ordinates, and that they reduce to the equations of a straight line for Galilean co-ordinates. This straight line is described with uniform velocity, so Einstein's equations may be regarded as a generalisation of Newton's first law of motion.

Applying these equations to the example given by Dr. Robb, we find that his space-time curve does not satisfy them unless  $F^2(x) = 0$ . This means that  $F(x)$  must be a linear function of  $x$  and so it cannot fulfil the required conditions of vanishing for two different values of  $x$ , except in the trivial case  $F(x) = 0$ . Thus the ambiguity seems to lie, not in Einstein's equations of motion, but merely in a particular method of arriving at them.

As regards the desirability of modifying Einstein's ideas on the nature of time, it is hazardous to give a definite opinion at present. It may be noted that Prof. Whitehead's new book ("The Principle of Relativity") endeavours to combine all the verifiable results of Einstein's theory with somewhat conservative ideas concerning space and time. The modified theory leads to some remarkable predictions (p. 129) which should be tested by experiment.

H. T. H. PRAGGIO.

University College, Nottingham,

November 4.

### The Dictionary of Applied Physics.

THE issue of NATURE of September 30, p. 439, contained a highly appreciative review of the first volume of the "Dictionary of Applied Physics," and, as editor, I am much indebted to the author for his kind words. One remark, however, has, I gather, led to some misunderstanding; may I have space for a brief explanation?

Dr. Kaye directs attention to some of the "omissions," with the view of their future rectification. Most of these "omissions" will be found dealt with in future volumes of the Dictionary. Thus, in an article in vol. iii., on Navigation and Navigational Instruments, by Commander T. Y. Baker, the gyro-compass is treated of very fully, while, in vol. v., Mr. Dobson has a highly interesting article on instruments used in aircraft.

It has been part of my plan to separate the mathematical treatment of a subject and its practical applications. In this manner I hoped to increase the utility of the work to various classes of readers, some of whom are interested chiefly in the theory, while others are more closely concerned with the more practical details.

R. T. GLAZEBROOK.

5 Stanley Crescent, Kensington Park Gardens,  
London, W.11.

### Action of Cutting Tools.

In the interesting letter which appeared in *NATURE* of August 26, p. 277, Mr. Mallock objects to the use of the word cutting as incorrect when applied to tools used for metal work, and it is surprising, therefore, to find that his own paper to which he refers in support of his contention is entitled "The Action of Cutting Tools," although it is almost entirely devoted to showing that the action of such tools is that of shearing.

In a further letter in *NATURE*, p. 603, of November 4, Mr. Mallock dismisses my paper as having no reference whatever to the action of cutting tools, apparently on the ground that it is entirely devoted to a consideration of elastic strains. So far as the tool itself is concerned, it is only useful so long as it does not become permanently deformed, and to the maker of tool steel, the stresses and strains produced within the elastic range are therefore matters of interest, so that an attempt was made in this paper to show the distribution of stress in the tool itself under these conditions.

In another section an account is given of the stress effects in the work when the tool is removing material therefrom, which are quantitative within the range for which the laws of photo-elasticity are known, and qualitative in the plastic region, as present knowledge is not sufficient to interpret fully the interference effects observed. Mr. Mallock ignores these latter effects, although they are undoubtedly of importance. They show, for example, that the action is sometimes discontinuous, and under other conditions is not so, although Mr. Mallock states quite definitely that it is always discontinuous and quasi-periodic. Mr. Mallock's letter also lays stress on the curling up of the shaving, but this does not always happen, as the discussion on my paper brought out the interesting fact that, as the speed increases, the curls of steel shavings increase in radius until at speeds of about two feet per second the shavings become practically straight and are often a danger to workmen. This effect has also been produced in nitro-cellulose at low speeds with a suitable tool, and it is then found that these straight shavings show permanent stress effects similar to those produced when a thin curved beam is flattened out.

E. G. COKER.

Engineering Laboratory, University College,  
London, W.C.1.

### A New Worship?

"Therefore no man that uttereth unrighteous things shall be unseen;

Neither shall Justice, when it convicteth, pass him by. For in the midst of his counsels the ungodly shall be searched out;

And the sound of his words shall come unto the Lord To bring to conviction his lawless deeds:

Because there is an ear of jealousy that listeneth to all things.

And the noise of murmurings is not hid. Beware then of unprofitable murmuring."

AFTER a period of ennobling worship in that greatest of our English Cathedrals, the Scaffell massif, on my return to town I chanced to enter that strange building, Burlington House, wherein be installed many altars to the great god, Science. Visiting that which ranketh first, I found an impressive figure, seated in a chair, at the High Altar, with a brass bauble before him: he needed but the peculiar head-dress to be an Egyptian Priest-King. Moreover, the service was apparently Græco-Egyptian, if not Babylonian. The officiating young priest used many beautiful words clearly of Grecian origin,

though at times an American phrase was noticeable, as when he spoke of Arrhenius doing chores, as I understood, for the god Isos. Most remarkable, however, was the way in which, at intervals, turning towards the altar, he solemnly gave utterance to the incantation—"See, Oh, Too!" My impression was that Too was the great king in the chair. The priest apparently was in fear of impending disaster, for at the close of his address he spoke much of concentration of the Hydrogen Ikons and their attack and repulse, often repeating the phrase "See, Oh, Too"—but Too seemed not to notice.

Two young acolytes then cast pictures of writing upon the wall as difficult to interpret as was that message expounded by Daniel in days long ago.

Most marvellous was the closing sermon, in which an account was given of the confusion wrought among a strange people, called "Lysodeiktics," by adding tears, nasal secretion, animal stews, turnip juice—seemingly muck of any kind—to their food: and how some of them were not killed. To one of an old faith, it seemed a strangely degenerate worship; indeed, that such service could be held worthy of attention amazed me.

In the evening, it chanced that I was led to peruse an article, in *The Times Literary Supplement*, on "Tradition and the French Academy," wherein is given Matthew Arnold's quotation, in his well-known essay, from the Academy's statutes:—

"The Academy's principal function shall be to work with all the care and all the diligence possible at giving sure rules to our language and rendering it *pure, eloquent and capable of treating the arts and sciences.*"

The whole article is worth reading; at the end is a quotation from a work by the late Pierre Duhem, the closing words being—

"*le respect de la tradition est une condition essentielle du progrès scientifique.*"

It is scarcely necessary to point out the application of these quotations; yet shall I ever pray: See to it, Oh, see to it, great Oh, Too!

HENRY E. ARMSTRONG.

### The Spectrum of Neutral Helium.

A MOST significant feature of the success of the quantum theory in explaining the sequence of radiation-frequencies forming the Balmer type of series in the spectra of hydrogen and ionised helium is that it also offers an intelligible explanation of the differences in the intensities of the successive lines in the sequence, and that its postulates are not inconsistent with the known facts regarding the sizes of the atoms in their normal states. The fundamental assumption in the theory is that the states of the atom represented by increasing quantum numbers depart more and more from the normal state, and the greater intensities of the earlier lines in a sequence are readily understood as due to the greater probability of transitions actually occurring between states represented by smaller quantum numbers.

Any attempt to build up a theory of spectra which ignores these fundamental considerations must be received with caution. The remark just made appears to be particularly applicable to Dr. Silberstein's attempt (*NATURE*, August 19) to explain the spectrum of neutral helium on the assumption of the independence of the electrons. Looking over the list of frequencies given in his letter, and comparing them with the maps and tables of the helium spectrum contained in Prof. Fowler's report, it is noticed at once that the well-known intense yellow line of helium at  $\lambda 5876$ , which is the first member of the diffuse series of doublets, is given by Dr. Silberstein the

formula  $9/6.15/6$ , while other lines which are of vanishingly small intensity in comparison with it are assigned formulae with much smaller quantum numbers. For example, the doublet at  $\lambda 3652$ , which is the seventh in the sharp series and so faint that it fails to appear in the photographic reproduction of the spectrum, is assigned the formula  $6/4.9/5$ . Similarly, the first diffuse singlet at  $\lambda 6678$  gets the formula  $9/6.24/7$ , while the fifth in the same series is indicated by  $7/5.19/5$ , that is, by much smaller quantum numbers, while it is actually a far fainter line than the other.

These facts naturally lead one to question whether Dr. Silberstein's proposed new combination principle has any real physical basis or significance. To settle this point, I undertook a careful survey of the figures and carried out a series of computations with the aid of my research student Mr. A. S. Ganesan, and have come to the conclusion that the approximate agreements between the calculated and actual frequencies are merely fortuitous arithmetical coincidences. This is clear from the following facts brought out by a survey of the figures:

(1) The proposed combination formula with its freedom of choice of four numbers gives a very large number of lines out of which it is possible to pick out a few coinciding approximately with practically any arbitrary series of frequencies which may be proposed, the accuracy of fit increasing as the quantum numbers chosen are increased.

(2) The coincidences between the calculated and observed frequencies are most numerous and accurate precisely in the region where the density of either series of frequencies is greatest, which is what we should expect according to the laws of chance.

(3) It is not, in general, possible to get a good fit for the earlier members of a line-series except by using large quantum numbers. This is what we should expect if the coincidences were fortuitous, as the frequency-differences between successive lines are greatest in the beginning of a series.

(4) More than one combination of quantum numbers will fit a given line tolerably well. For example, the  $D_3$  line of helium is also represented fairly well by  $13.21/5.12$ .

(5) The quantum numbers giving the best fit do not fall into any regular sequence when arranged either according to the frequencies of the lines or their intensities, nor do they show any characteristic differences for the singlet and doublet series.

Needless to say, the foregoing remarks apply with even greater force to the case of the lithium atom when a choice of six numbers is permitted.

Finally, it may be remarked that the Rydberg constant 109723 chosen by Dr. Silberstein is appropriate only to the case of the ionised helium atom in which only one electron is coupled to the nucleus. If both electrons exert reactions on the nucleus and move simultaneously, the value of the Rydberg constant cannot remain the same in general.

C. V. RAMAN.

210 Bowbazaar Street, Calcutta,  
October 18, 1922.

### Water Snails and Liver Flukes.

HAVING been attracted on several occasions by the presence of actively swimming cercariae of *Fasciola hepatica* in material collected for protozoan studies and searching for the intermediate host, I have come across several examples of *Limnaea peregra* harbouring perfectly developed cercariae of the same species. Prof. Graham Kerr has also had similar experiences.

May I claim the hospitality of your pages to ask of your readers for references to literature dealing with the subject of any intermediate host, other than *L. truncatula*, of the liver-rot parasite? Mr. Staig has kindly informed me that Prof. J. W. W. Stephens writes in "Animal Parasites of Man," by Fantham, Stephens and Theobald: "In the allied species of *L. peregra* the fluke will develop up to a certain stage but never completes all its various phases." Many text-books in zoology give one the impression that *L. truncatula* is the only intermediate host.

My experience in searching for *L. truncatula* is that the occurrence of the snail is very local in S.W. Scotland. It seems to be rare, or altogether absent in some districts. Yet in these districts the sheep are known to be infected with the liver-rot disease. It would seem, then, that *L. peregra* acts as the normal intermediate host in those districts, the *Fasciola* completing within its body in normal fashion the life cycle up to the stage when the cercaria becomes free.

MONICA TAYLOR.

Notre Dame, Downhill, Glasgow.

### A Mutation of the Columbine.

LAST summer a remarkable mutation of the blue columbine (*Aquilegia caerulea* James) was discovered by Miss Madeline Gunn near the Smuggler Mine, in the vicinity of Ward, Colorado. Only a single plant was found, growing under a spruce tree. The flowers are of good size (about 63 mm. diameter), with the pale blue sepals deeply trifid apically, the divisions about 12 mm. long, broad basally, the outer ones overlapping the median one (Fig. 1). In one case the median division is bifid apically. The petals are white, the laminae and spurs shorter than usual.



FIG. 1.

The form may be called *mut. trifida*; it represents a striking new type which, if it can be propagated, will be a notable addition to horticulture. Were it received from some remote region, it would appear to be a very distinct new species, or some might even wish to separate it generically. The trifid structure is characteristic of the divisions of the leaves of *Aquilegia*, and no doubt we may say that a quality of the leaf has been transferred to the sepals. Numerous cases of phylloidy of the calyx in various flowers have been described by Maxwell Masters and others, but in this case the sepals are not at all leaf-like, and if such flowers were common they would not strike any one as abnormal.

T. D. A. COCKERELL.  
DOROTHY YOUNG.

University of Colorado.

The Atoms of Matter; their Size, Number, and Construction.<sup>1</sup>

By Dr. F. W. ASTON, F.R.S.

THAT matter is discontinuous and consists of discrete particles is now an accepted fact, but it is by no means obvious to the senses. The surfaces of clean liquids, even under the most powerful micro-

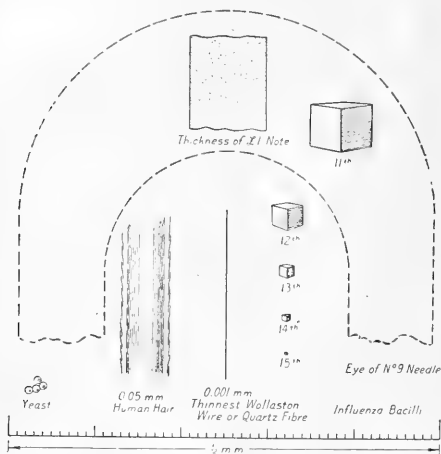

FIG. 1.—Cubes 11 to 15 compared with familiar objects to scale.

scope, appear perfectly smooth, coherent, and continuous. The merest trace of a soluble dye will colour millions of times its volume of water. It is not surprising, therefore, that in the past there have arisen schools which believed that matter was quite continuous and infinitely divisible.

The upholders of this view said that if you took a piece of material, lead, for example, and went on cutting it into smaller and smaller fragments with a sufficiently sharp knife, you could go on indefinitely. The opposing school argued that at some stage in the operations either the act of section would become impossible, or the result would be lead no longer. Bacon, Descartes, Gassendi, Boyle, and Hooke were all partial to the latter theory, and Newton in 1675 tried to explain Boyle's law on the assumption that gases were made up of mutually repulsive particles.

The accuracy of modern knowledge is such that we can carry out, indirectly at least, the experiment suggested by the old philosophers right up to the stage when the second school is proved correct, and the ultimate atom of lead reached. For convenience, we will start with a standard decimetre cube of lead weighing 11.37 kilograms, and the operation of section will consist of three cuts at right angles to each other, dividing the original cube into eight similar bodies each of half the linear dimensions and one-eighth the weight. Thus the first cube will have 5 cm. sides and weigh 1.42 kilograms, the second will weigh 178 gm., the fourth 2.78 gm., and so on. Diminution in the

<sup>1</sup> From an evening discourse delivered before the British Association at Hull, September 12, 1922.

series is very rapid and the result of the ninth operation is a quantity of lead just weighable on the ordinary chemical balance. The results of further operations are compared with suitable objects and a scale of length in Figs. 1, 2, and 3. The last operation possible, without breaking up the lead atom, is the twenty-eighth. The twenty-sixth cube is illustrated in Fig. 3. It contains 64 atoms, the size, distance apart, and general arrangement of which can be represented with considerable accuracy, thanks to the exact knowledge derived from research on X-rays and specific heats. On the same scale are represented the largest atom, cesium, and the smallest atom, carbon, together with molecules of oxygen and nitrogen, at their average distance apart in the air, and the helical arrangement of silicon and oxygen atoms in quartz crystals discovered by X-ray analysis. The following table shows at what stages certain analytical methods break down. The great superiority of the microscope is a noteworthy point.

Cube.	Side in Cm.	Mass in Gm.	Limiting Analytical Method.
9	0.0195	$8.5 \times 10^{-6}$	Ordinary Chemical Balance
14	$6.1 \times 10^{-4}$	$2.58 \times 10^{-9}$	Quartz Micro-balance
15	$3.05 \times 10^{-4}$	$3.22 \times 10^{-10}$	Spectrum Analysis (Na lines)
18	$3.8 \times 10^{-5}$	$6.25 \times 10^{-13}$	Ordinary Microscope
24	$6.0 \times 10^{-7}$	$2.35 \times 10^{-18}$	Ultra Microscope
28	$3.7 \times 10^{-8}$	$5.15 \times 10^{-22}$	Radioactivity
Atom.	$3.0 \times 10^{-8}$	$3.44 \times 10^{-23}$	

Just as any vivid notion of the size of the cubes passes out of our power at about the twelfth—the limiting size of a dark object visible to the unaided eye—so when one considers the figures expressing the number of atoms in any ordinary mass of material, the mind is staggered by their immensity. Thus if

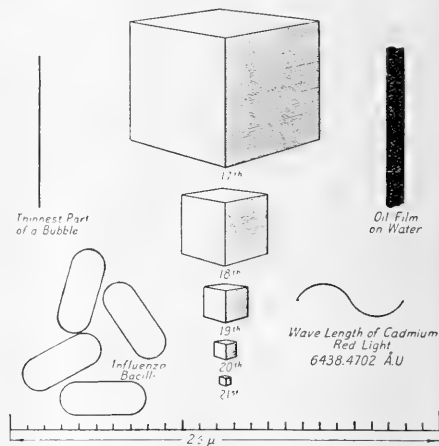

FIG. 2.—Cubes 17 to 21 compared with minute objects to scale.

we slice the original decimetre cube into square plates one atom thick the area of these plates will total one and one-quarter square miles. If we cut these plates into strings of atoms spaced apart as they are in the



solid, these decimetre strings put end-to-end will reach 6.3 million million miles, the distance light will travel in a year, a quarter of the distance to the nearest fixed star. If the atoms are spaced but one millimetre apart the string will be three and a half million times longer yet, spanning the whole universe.

Again, if an ordinary evacuated electric light bulb were pierced with an aperture such that one million molecules of the air entered per second, the pressure in the bulb would not rise to that of the air outside for a hundred million years. Perhaps the most striking illustration is as follows: Take a tumbler of water and—supposing it possible—label all the molecules in it. Throw the water into the sea, or, indeed, anywhere you please, and after a period of time so great that all the water on the earth—in seas, lakes, rivers, and clouds—has had time to become *perfectly mixed*, fill your tumbler again at the nearest tap. How many of the labelled molecules are to be expected in it? The answer is, roughly, 2000; for although the number of tumblersful of water on the earth is  $5 \times 10^{21}$ , the number of molecules of water in a single tumbler is  $10^{25}$ .

From the above statements it would, at first sight, appear absurd to hope to obtain effects from single atoms, yet this can now be done in several ways, and indeed it is largely due to the results of such experiments that the figures can be stated with so much confidence. Detection of an individual is only feasible in the case of an atom moving with an enormous velocity when, although its mass is so minute, its energy is quite appreciable. The charged helium atom shot out by radioactive substances in the form of an alpha ray possesses so much energy that the splash of light caused by its impact against a fluorescent screen can be visibly detected, the ionisation caused by its passage through a suitable gas can be measured on a sensitive electrometer and, in the beautiful experiments of C. T. R. Wilson, its path in air can be seen and photographed by means of the condensation of water drops upon the atomic wreckage it leaves behind it.

In the first complete Atomic Theory put forward by Dalton in 1803 one of the postulates states that: "Atoms of the same element are similar to one another and equal in weight." Of course, if we take this as a definition of the word "element" it becomes a truism, but, on the other hand, what Dalton probably meant by an element, and what we understand by the word to-day, is a substance such as hydrogen, oxygen, chlorine, or lead, which has unique chemical properties and cannot be resolved into more elementary constituents by any known chemical process. For many of the well-known elements Dalton's postulate still appears to be strictly true, but for the others, probably the majority, it needs some modification.

Throughout the history of science philosophers have been in favour of the idea that all matter is composed of the same primordial substance, and that the atoms of the elements are simply stable aggregations of atoms of this substance. Shortly after Dalton's theory had been put forward Prout suggested that the atoms of the elements were composed of atoms of a substance he called "protyle," which he endeavoured to identify with hydrogen.

If Dalton and Prout were both right the combining

weights of the elements should all be expressible as whole numbers, hydrogen being unity. Experimental evidence showed this to be impossible in many cases. Chemists therefore wisely preferred Dalton's theory, which was in accord with definite though fractional atomic weights, to Prout's, which would necessitate the elements of fractional atomic weight being heterogeneous mixtures of atoms of different weight.

The idea that atoms of the same element are all identical in weight could not be challenged by ordinary chemical methods, for the atoms are by definition chemically identical, and numerical ratios were only to be obtained in such methods by the use of quantities of the element containing countless myriads of atoms. At the same time it is rather surprising, when we consider the complete absence of positive evidence in its support, that no theoretical doubts were publicly expressed until late in the nineteenth century, first by

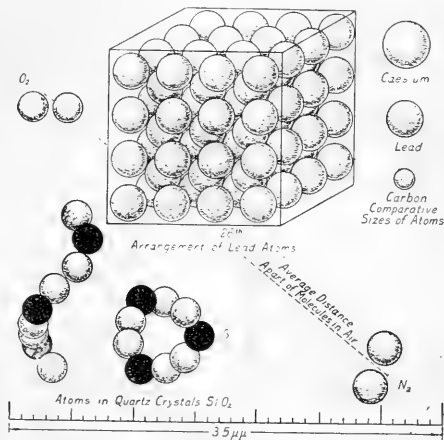

FIG. 3.—Cube 26 showing atoms with scale of reference.

Schutzenberger and then by Crookes, and that these doubts have been regarded, even up to the last few years, as speculative in the highest degree. In order to dismiss the idea that the atoms of such a familiar element as chlorine might not all be of the same weight, one had only to mention diffusion experiments and the constancy of chemical equivalents. It is only within the last few years that the lamentable weakness of such arguments has been exposed and it has been realised that the experimental separation of atoms differing from each other by so much as 10 per cent. in weight, is really an excessively difficult operation.

There are two ways by which the identity of the weights of the atoms forming an element can be tested. One is by the direct comparison of the weights of individual atoms; the other is by obtaining samples of the element from different sources or by different processes, which, although perfectly pure, do not give the same chemical atomic weight. It was by the second and less direct of these methods that it was first shown by the experiments of Soddy and others on the atomic weight of lead from different radioactive

sources, that substances could exist which, though chemically identical, had different atomic weights. These substances Soddy called "isotopes" as they occupy the same place in the periodic table of the elements.

The first experimental comparison of the weights of individual atoms was made by Sir J. J. Thomson in his analysis of positive rays by the "parabola" method. Subjected to this test most of the lighter elements appeared to follow Dalton's rule, but the results with the rare gas neon suggested the possibility of the atoms of this element being of two different weights, roughly 20 and 22 respectively. In other words the parabolas of neon indicated that it might be a mixture of isotopes, but the accuracy of measurement by this method was not sufficient to settle the point with certainty.

The requisite accuracy has been obtained by an instrument for the analysis of positive rays called the "mass-spectrograph." By this device, the weights of atoms can be compared to an accuracy of one-tenth per cent., and it has been demonstrated not only that neon (20.2) is a mixture of atoms of weights exactly 20 and 22, but also that chlorine (35.46) is a mixture of isotopic atoms of weights 35 and 37. Furthermore, about half the elements investigated turn out to be mixtures, some of the heavier ones consisting of six or more different constituents. Most important of all is the fact that every element investigated, with the exception of hydrogen, consists of atoms the weights of which are expressible as whole numbers on the oxygen scale used by chemists.

This remarkable generalisation called the "whole number rule" has removed the last obstacle in the way of the unitary theory of matter. We now have no hesitation in affirming that Nature uses the same standard bricks in the construction of the atoms of all elements, and that these standard bricks are the primordial atoms of positive and negative electricity, protons and electrons.

These are the natural unit charges of electricity, equal but of opposite sign. Of the shape of these particles we know next to nothing, but the wonderful advances of modern physics, in particular those of radioactivity, enable us to speak of their weights and dimensions with some assurance. The weight of the proton is very nearly the weight of a hydrogen atom, the electron is nearly two thousand times lighter, so that the atomic weight of an element (not consisting of isotopes) will be roughly equal to the number of protons in its atoms. The dimensions of the electron are about one hundred thousand times less than those of the atoms as illustrated above, and the proton is probably nearly two thousand times smaller still.

We now know of what atoms are constructed, and may go on to consider the evidence as to how their constituent parts are arranged. In the foregoing diagrams the atoms are represented as spheres, and in respect to the small forces and velocities which occur in the collisions between the atoms of gases at ordinary temperatures they do behave very exactly as smooth elastic spheres. But unfortunately the idea of a sphere carries the suggestion of a portion of space full of something; that is, the atom as a sort of spherical bag packed full of electric charges. Nothing could be further from the actuality, for from the figures

already given, it can be seen at once that even in the heaviest atom known the constituent charges fail to fill even the million millionth part of its whole volume. To convey any direct idea of these numerical relations by diagrams is practically hopeless, and were we to construct a scale model of the atom as big as the dome of St. Paul's we should have some difficulty in seeing the electrons, which would be little larger than pin heads, while the protons would escape notice altogether as dust particles invisible to the unaided eye. Experimental evidence leaves us no escape from the astounding conclusion that the atom of matter, as a structure, is empty, empty as the solar system, and what we measure as its spherical boundary really only represents the limiting orbits of its outermost electrons.

The hypothesis which has led to the greatest advances in our knowledge of the inner construction of atoms is Rutherford's theory of the "nucleus atom" put forward in 1911. This is supported by so many results of direct experiment that it is now universally accepted and must be substantially correct. It postulates that all of the positive and about half of the negative electricity, that is, practically the entire weight, of the atom is concentrated at its centre, forming a very small body called the nucleus. In other words, all the protons and about half the electrons in the atom are packed together, forming a sort of sun round which revolve the remaining electrons as planets. The number of protons in excess of electrons in the nucleus will clearly be its net positive charge, and since this will not depend on the gross numbers of protons and electrons but only on their difference, we can have elements the atoms of which have nuclei of different weights but the same net charge. These are isotopes, for the chemical properties of an atom are determined by the charge on its nucleus.

The nucleus is extremely small compared with the whole atom. Thus, if in the atom of helium atomic weight 4 atomic number 2 we take the nucleus, consisting of 4 protons and 2 electrons, as represented by a rather large pea, its planetary electrons may be represented on the same scale as two rather smaller peas revolving round it at a distance of a *quarter of a mile*. The dislodgement of one of its planetary electrons from an atom requires comparatively little energy and is the well-known process called ionisation. This change is only a temporary one, as the atom takes the first opportunity of attracting it or any other stray electron back into its orbit and becoming neutral again. It is by a sort of continual exchange of such loose electrons that electricity is conducted along metallic wires. Disruption of the nucleus, on the other hand, needs enormous energy, but once performed must give rise to the atom of a new element. This process of transmutation has been achieved by Sir Ernest Rutherford, in the case of some of the lighter elements, by bombarding their atoms with alpha rays, which are charged helium nuclei expelled at enormous speeds from radioactive atoms during their natural process of disintegration. From the tiny dimensions of the nucleus compared with those of the atom it is obvious that the chance of getting a direct hit on the nucleus is only one in many millions, but the experiments show that when this does take place

protons are dislodged from the atoms of the element struck and that therefore transmutation has been actually carried out.

The quantity of matter so transmitted is indeed almost inconceivably small, but it is the first step towards what may well be the greatest achievement of the human race, the release and control of the so-called "atomic energy." We now know with certainty that four neutral hydrogen atoms weigh appreciably more than one neutral helium atom, though they contain identically the same units, 4 protons and 4 electrons. The change of weight is probably due to the closer "packing" in the helium nucleus, but whatever the explanation may be transmutation of hydrogen into helium must inevitably destroy matter and therefore liberate energy. The quantity of energy can be calculated and is prodigious beyond the dreams of scientific fiction. If we could transmuted the hydrogen contained in one pint of water the energy so liberated would be sufficient to propel the *Mauretania* across

the Atlantic and back at full speed. With such vast stores of energy at our disposal there would be literally no limit to the material achievements of the human race.

The possibility that the process of transmutation might be beyond control and result in the detonation of all the water on the earth at once is an interesting one, since, in that case, the earth and its inhabitants would be dissipated into space as a new star, but the probability of such a catastrophe is too remote to be considered seriously. A recent newspaper article pointed out the danger of scientific discovery, and actually suggested that any results of research which might lead to the liberation of atomic energy should be suppressed. So, doubtless, the more elderly and apeline of our prehistoric ancestors grumbled at the innovation of cooked food, and gravely pointed out the terrible dangers of the newly-invented agency, fire, but it can scarcely be maintained to-day that subsequent history has justified their caution.

### The Herring Fishery and its Fluctuations.

By B. STORROW, Dove Marine Laboratory, Cullercoats, Northumberland.

HERRINGS are fished in every month of the year, and the catches show considerable variation in the size of the fish, the state of the reproductive organs, and the age composition of the shoals. It is necessary, therefore, before arriving at any conclusion with regard to the fishery, to take into consideration the kinds of herrings which are caught on the different grounds throughout the year.

In the beginning of the year, January, February, and March, shoals are fished about the north-west of Ireland, off the north of Scotland, including the Shetlands and Orkneys, and in the Firth of Forth. These herrings are all fish with the gonads well developed, and they spawn towards the end of February or in March. They are known as spring spawners and, except for the shoals of the Firth of Forth, they, so far as the western part of the North Sea is concerned, are caught in northern waters. In April the spent fish from the spring spawning shoals are caught all over the North Sea, from the Shetlands to Bergen Bank, from North Shields to the Naze, and off Yarmouth and Lowestoft. The catches are used chiefly for bait by the drift-net fishermen, who at this time are fishing with lines for cod, ling, halibut, etc. Among some of the bait catches are found numbers of small fish with the gonads not developed, and without doubt these can be classified as virgin fish.

During May the number of drifter-liners decreases and catches of herrings are made from ten to thirty miles off our coast. These catches consist of young fish with the gonads at practically the same stage of development as those found in catches made in April, 100 miles from the nearest port, and when, for the offshore and inshore fish, the growth as calculated from the scales is compared, the agreement warrants the conclusion that the young fish have moved shoreward from the deeper waters. In good seasons this movement towards the shore coincides with increased landings of herrings.

Throughout June waves of migrating herrings come on to the grounds, and in the beginning of July the migrations are large enough to bring about a considerable increase in the fishery. These June and early July

migrants have been found, off the Northumberland coast, to be marked with a comparatively small first-year growth, as determined from the scales, which, for the most part, show three winter rings. Recovering spents from spring spawning shoals are found among catches of young developing herrings, but after the beginning of July they disappear, or the numbers found are insignificant.

Herrings with three winter rings and with a comparatively larger first-year growth than the June fish invade the grounds during July and August and give the high catches which are taken in these months in a successful fishery. Towards the end of August and the beginning of September shoals of larger and older herrings appear. They are full fish with their reproductive organs developed, and they, together with the young herrings sufficiently developed, form autumn spawning shoals. After spawning they disappear quickly and only young fish are to be caught.

The summer fishery of the east coast, the Shetlands excluded, is one which depends chiefly on young fish, and samples examined from Wick to Scarborough have been found to contain from 50 to 70 per cent. of fish with three winter rings on their scales. Fish of this age, therefore, determine the productivity of the fishery.

In September herrings are caught in the vicinity of the Dogger Bank by Dutch luggers and by trawlers, off Scarborough and Grimsby by drift-nets. Some of these fish are autumn spawners, but some, especially those caught by trawlers, are spring spawners, which now make their reappearance in great numbers. An examination of catches made on these grounds points to the herrings coming from the north-east to the south-western end of the Dogger Bank and then moving in a south-westerly direction to the Grimsby grounds.

The East Anglian harvest begins in September and continues to the beginning of December. In the early part of the fishery many of the catches are landed from the grounds off Grimsby and it is not until October that the large fleets concentrate off Yarmouth and Lowestoft. This fishery is essentially one for full

herrings and, although small numbers of spawning fish and spents are caught, the bulk of the catches consists of fish which will become spring spawners. The herrings are of all ages, from fish with three winter rings to those with as many as nine or ten, and the samples obtained from these shoals point to the older fish being the latest migrants.

The herring fishery of the southern part of the North Sea differs from that of the east coast in that it depends for its success upon the presence of older and adult fish. In this respect it is like the fishery in northern waters about the Shetlands. But both these fisheries must receive additions from the summer shoals of developing fish if they are to continue in existence, and the question of their productivity cannot be considered without reference to the younger shoals.

For other waters we have not the same quantity of data as we have for the North Sea. In the Minch and off the north-west of Ireland there are spring and autumn spawners and summer shoals of developing fish. In the Irish Sea the summer feeding shoals are followed by autumn spawners, but for these waters, owing to the large numbers of herrings with two winter rings found in the catches of 1921, further investigations are required before a definite statement can be made as to the age when the young fish join commercial shoals in greatest numbers.

The poor summer fishery of 1920 and its failure in 1921 can be accounted for by a shortage of fish with three winter rings and belonging to the year-classes of 1917 and 1918. For an explanation of the poor catches from shoals of adult herrings a consideration of their age composition is necessary. Samples examined in 1919, 1920, 1921, and the spring of 1922, and obtained not only from the East Anglian shoals but from the north-west of Ireland and the north of Scotland, have contained large numbers of fish of the 1913 and 1914 year-classes. In all samples the year-class of 1915 has been poorly represented. The year-class of 1916, which gave the fairly successful summer fishery of 1919 when the young fish had then three winter rings, can be considered a good but not a rich year-class. The older herrings have naturally decreased in numbers and the samples and catches obtained from shoals of adult fish give no indication that a rich year-class of young herrings has joined these shoals.

While a consideration of the age composition of the shoals leads to the conclusion that the failure of the fishery is due to the relative value of the different year-classes it indicates also that the migrations have had some effect. Although we know little about the migrations of the herring, there appears to be no doubt that the migrations of the fish which have become adult and joined spawning shoals differ from those of the young which have not yet spawned. In the spring of 1921 comparatively large numbers of young herrings with three growth areas on the scales were found as full fish among the samples from the north of Scotland and the Firth of Forth. Further sampling in 1922 has confirmed the finding of the previous year. Now, fish of this age in the spring of the year are those which, in June, July, and August, determine the yield from the summer fishery. Since large numbers of them had spawned in the spring of 1921, and afterwards would migrate as adult fish, the summer fishery of that year

was poorer by reason of their absence. The high catches made this year from the waters about the Shetlands came, in part, from grounds which have been unproductive for a number of years, and they point to migrations which we know have followed the activity of Atlantic waters and herrings reaching maturity at an early age.

The age composition of the adult shoals fished off the north-west of Ireland, the north of Scotland, and in the southern North Sea, does not permit of the idea that the conditions which govern the fishery occur in small areas only. A consideration of the 1904 year-class from data accumulated by Hjort and Lea gives some idea of the widespread nature of the factors which produce good year-classes. In the southern waters of the Gulf of St. Lawrence the year-class of 1903 was found to predominate, and that of 1904 in the northern waters of the Gulf. The same year-class was the mainstay of the Norwegian fishery for a number of years and was rich in Icelandic waters. The large catches on the east coast of Scotland in 1907 can be referred to the 1904 year-class, and so can the good fisheries of the English Channel in 1909 and 1910. The conditions producing good year-classes extend over the greater part of the North Atlantic area. The difference between the north-west of Ireland fishery and that of the North Sea in 1909 and 1910 suggests that in some years, *e.g.* 1905, the factors which govern year-classes may move along the west coast of Ireland towards the North Sea. The age composition of the shoals in 1919-1921 indicates the coincidence of conditions over the area north-west of Ireland north into the North Sea. That variations in oceanic circulation may bring about local changes in the fishery would appear from the failure of the Firth of Clyde fishery, 1904-1920, and that of the west of the Shetlands, 1905-1922. The disappearance of young herrings from the Wash points to the same conclusion.

To say that fluctuations in the herring fishery have been observed since the beginning of the fishery is to make a statement incapable of proof but one which is extremely probable. The history of the fishery, so far as we know it, consists of a series of fluctuations, and the attempts to account for these have given rise to explanations which have varied from the conditions of the year of capture to the wickedness of the people.

However ridiculous some of these old opinions may appear, it is only since Norwegian investigators, Hjort, Dahl, and Lea, directed attention to the scales of the herring that we have had any definite knowledge of the age composition of some of the herring shoals. Few people think of herrings in their fourth year as being of greatest importance in our summer shoals; a still smaller number think of the conditions of the year of hatching as being the factor which determines good and poor year-classes. Evidence recently examined points to this view requiring some modification and to the possibility that the conditions of the year preceding hatching are the dominant factor in the production of good year-classes. Whatever modification may be needed for this latest idea will depend on the knowledge we hope will be obtained of the life of the herring before it enters the commercial shoals.

That the conditions preceding hatching are of greatest importance is indicated by some of the results obtained when this has been taken as a working hypothesis and

a period of four years allowed between hydrographic phenomena and herring catches. For a period of fifty years it has been possible to show a relation between the range of tide at Aberdeen and the productivity of the herring fishery of the east coast of Scotland. The curves representing tidal data and herring catches show periods in which they tend to parallelism and to convergence, but until this periodicity is understood and can be foreseen the result will be of little use commercially. Good year-classes can be referred to the activities of Atlantic water, which have been shown by Pettersson to depend upon the periodic variation of lunar influence, but more definite knowledge is required as to the time, intensity, and direction of invasions of Atlantic water into the North Sea. This is particularly illustrated by the conditions which are held to have produced the 1907 year-class, which gave the rich fishery on the east coast of Scotland in 1910. The wide-spread occurrence of the rich year-class of 1904 which was found in the Gulf of St. Lawrence and in practically all waters of north-west Europe suggests that a study of the hydrographic conditions of the North Sea alone is insufficient for a full understanding of the factors which determine the wealth of the different year-classes.

Although the production of good year-classes has the greatest influence on the fishery in that these year-classes give a herring population sufficiently large to yield a succession of large catches throughout the season, or a number of seasons, the migrations of the herrings have an effect which is considerable and they may in some cases bring about the formation of new fisheries or the non-existence of others. Pettersson has shown how the great Baltic herring fishery of the Middle Ages coincided with a maximum activity of Atlantic waters, due to the greatest possible tidal influence of the moon and sun, and, also how the present Baltic fishery fluctuates in a period of eighteen to nineteen years. These fluctuations are noticeable chiefly in shoals of adult fish, and, in our waters, for the shoals off East Anglia and the winter herrings of the east coast of Scotland, they have

been found to alternate with those of the Baltic fishery. The composition and nature of the shoals about the Shetlands this year point to migrations which have followed the most recent invasion of Atlantic waters, with which has coincided the lateness of the appearance of the Northumberland July shoals in 1920 and 1921 and of the shoals fished from Yarmouth in September 1921. Before we can hope to understand this periodicity in migrations and the difference from year to year in the arrival of our shoals a much more comprehensive knowledge of the hydrography of the North Sea and of the factors controlling the movements of the waters of the North Atlantic is required. Further, the publication of the statistics relating to the fishery in a form which will allow of their examination as to where and when the catches were made is desirable.

That the poor quality of the herrings and the early maturity of the younger year-classes have coincided with one another and with the presence of large quantities of Atlantic water cannot be taken as solving the problem of their occurrence. Neither does the poor liver yield from Norwegian cod, which, in some years at least, coincided with large numbers of young fish among adult cod and with Atlantic water activity, throw any further light on what must be regarded as a physiological problem awaiting investigation, and one which cannot be considered as explained by a reference to a possible scarcity of copepods.

The problem of the fluctuations in our herring fishery is not one which can be solved by a consideration of one or two isolated sets of phenomena. That the activity of Atlantic water has a connexion with periodicity in the fishery and with the production of good year-classes suggests a possible way of approach. It is a problem which demands the attention not only of the zoologist and the hydrographer, but also of the physiologist and probably that of the astronomer. Further, it must not be forgotten that the men engaged in the fishery and the industries connected therewith are concerned more about the fluctuations from year to year than those which are spread over much longer periods.

### The Nebraska Tooth.

By W. P. PYCRAFT.

AT the meeting of the Zoological Society on November 7, Prof. Elliot Smith exhibited a cast of the now famous Nebraska tooth, which is regarded by American palaeontologists as representing a new genus and species of the human race—*Hesperopithecus haroldcooki*. This tooth—a "second upper molar"—differs, we are assured, on one hand from that of any known anthropoid apes, and on the other from any of the primitive types of man yet discovered.

Prof. Elliot Smith is in agreement with this interpretation; and presented fresh evidence in its support, furnished him by Prof. Osborn. This evidence included the results of radiographing the tooth, together with the teeth of a chimpanzee and Piltdown man. But these, it must be admitted, were unconvincing pictures, since they failed to demonstrate the features they were designed to show.

The teeth of the Piltdown man, it will be remembered, showed a large pulp-cavity placed above the level of

the alveolar border of the jaw, as in modern man; wherein, however, the cavity is smaller. But the Piltdown teeth, in this regard, differ as much from the teeth of Neanderthal man, wherein the pulp-cavity was of great size, and evidently developed at the expense of the roots. Sir Arthur Keith has called such teeth "taurodont." They are peculiar to men of the Neanderthal type. The Piltdown teeth, like those of the modern man, are of the "cynodont" type. This fact, it may be predicted, will come to have an additional significance in the near future.

Dr. A. Smith Woodward, in the discussion which followed Prof. Elliot Smith's remarks, reaffirmed his original belief—expressed at the time when the discovery of the Nebraska tooth was first announced, and set forth in NATURE of June 10 (vol. 109, p. 750)—that this tooth was more probably that of one of the primitive, extinct bears (*Hyaenarctos*), than of some primitive member of the primates. Prof. Osborn

dismisses this suggestion on the ground that "the difference is so fundamental that it is difficult to find any single point of agreement." But from Prof. Osborn's own account of this tooth, which appeared in *NATURE* of August 26, p. 281, it is a no less difficult matter to discover harmony between this tooth and the molars of any of the primates, living or extinct. We cannot escape the conclusion, in short, that the evidence as to the true character of the Nebraska tooth has been only partly sifted. Before we can consider ourselves in possession of the whole of the evidence it must be carefully compared with worn teeth of *Hyenarctos*, and its near allies. Radiographs of such teeth are essential. For the moment the material for such a comparison is, doubtless, limited: but even this can, and must, be taken into account. We trust that Prof. Osborn will see his way to supplement the able summary he gave us in *NATURE*, in August last, wherein he contrasts the tooth of

*Hesperopithecus* with the teeth of chimpanzee and *Pithecanthropus*, by a similar pictorial comparison between this remarkable tooth and the teeth of the fossil bears, or at least a *Hyenarctos*.

The extremely worn condition of this tooth compels caution in every statement made concerning it: and more especially on the part of those who have never seen and handled the actual specimen. The danger of dogmatizing on the evidence afforded by photography and casts alone, was forcibly illustrated in the case of the skull of *Pittdown man*. But it is also imperatively necessary, in the interests of science, that even remotely possible relationships should be seriously examined. It is always unwise to assume that what *ought* to be, *must* be. We cannot help feeling that this applies very pertinently in the case of the Nebraska tooth: and that therefore it would be wise at any rate to entertain the *suggestion*, that it may, after all, represent one of the *Ūrsidæ*, instead of one of the *Hominidæ*.

### Obituary.

MRS. A. D. WALLER.

THE announcement of the death on October 22, at sixty-three years of age, of Mrs. Waller, widow of the late Dr. A. D. Waller, must have been noticed with regret by many workers in the world of science. Alice Mary Palmer, which was Mrs. Waller's maiden name, had early aspirations towards a medical career, and after matriculating in the University of London she took up her medical course at the London School of Medicine, where she became the pupil of Dr. Augustus Waller, then lecturer in physiology at the School. Miss Palmer was appointed his demonstrator—a post which she filled with enthusiasm. His original and stimulating lectures were a great delight to her, and the relationship of teacher and pupil ripened rapidly into a closer one.

Husband and wife had much in common: both cared intensely for education and worked throughout their lives for what they considered its best interests. After her marriage Mrs. Waller's chief concern was for her husband's work. In all that he did she had her part; she enjoyed the whole technique of laboratory work, owning apologetically that even a bit of "mere" anatomy never came amiss to her. The house in Grove End Road, which soon became such a centre for scientific interests, was secured for the young couple early in their married life. It was an unusual household, being at once both laboratory and home, and its ways were unconventional; but to those who caught the spirit of the place, the charm of its hospitality was irresistible. All who cared for scientific work were welcomed there, and to the student who sought her advice Mrs. Waller became at once friend, champion, and helper. Foreign friends, distinguished and undistinguished, made Weston Lodge their resting-place when visiting London, and much good talk was heard within the walls of the old study—great were the discussions, vigorous the arguments, and over all debates played the gentle humour of the hostess, softening the sometimes mordant wit of her husband.

During the latter years of their lives the centre of interest was transferred, for the Wallers, from Weston Lodge to the University Laboratory at South

Kensington. That laboratory fulfilled to a large extent the purpose for which it was founded. Many will remember it as a place of help, inspiration; and fruitful work, and it may safely be said that there are none who ever worked there but will remember with affectionate gratitude the gentle woman who cared so greatly for the destinies of the laboratory and for the welfare of each of its individual workers.

LADY HERDMAN.

In educational and scientific circles widespread sympathy is felt with Sir William Herdman at the death of Lady Herdman on November 7. His loss is shared by all who knew Lady Herdman, as well as by many others to whom her life and work were both a stimulus and a standard. Lady Herdman was a daughter of the late Mr. Alfred Holt, and was a student at University College, Liverpool, when Sir William Herdman was professor of natural history there. She graduated in science at London University in 1891, with first-class honours in physics, and in the following year became the first president of the Women Students' Representative Council at Liverpool. She was thus an active worker in the University College of the city before it became the University of Liverpool in 1903; and in promoting this development, as well as since, Lady Herdman was closely associated with her distinguished husband. The scientific world gratefully remembers how in 1916, in commemoration of the death of their brilliant son George in the battle of the Somme, they gave the sum of 10,000*l.* to the university for the foundation of the George Herdman chair of geology, and three years later founded and endowed the chair of oceanography in the university. In these and many other ways, as, for example, by devoted service on the Liverpool Education Committee, of which she was a co-opted member, Lady Herdman exercised an influence which was always beneficial and often more far-reaching than she herself ever conceived. She possessed wisdom as well as knowledge, and the remembrance of her life will long be cherished with affection, to console as well as to inspire.

## Current Topics and Events.

THE presence of the Prince of Wales at the dinner arranged by the Institution of Mining Engineers and the Institution of Mining and Metallurgy at the Guildhall, London, on November 16, gave Royal distinction to a memorable occasion in the history of applied science in this country. The Prince himself, in his tribute to the mining engineer, referred with particular approval to the amalgamation of the two institutions and remarked: "I cannot help feeling that there are in this country many institutions, scientific and otherwise, which might do well to follow your example, and, as you have done, group themselves round a joint secretariat and library, housed in a single building." The combined membership of the two institutions is more than 6300, and the two councils have decided to invite the sister-institutions in the British Isles and the Dominions to co-operate with them as equal partners in the constitution of an Empire Council of Mining and Metallurgical Engineering Institutions. Sir John Cadman, president of the Institution of Mining Engineers, who presided at the dinner and was associated with Mr. S. J. Speak, president of the Institution of Mining and Metallurgy, in referring to this new body linking up members of the mining profession throughout the British Empire in a concerted effort of practical achievement, expressed to the American Ambassador, who was present, the hope that such a scheme would find favour in the United States and ultimately embrace all English-speaking mining and metallurgical engineers. The importance which the Institution of Mining and Metallurgy attaches to technological education was shown by the presentation of the gold medal of the institution to Sir Alfred Keogh, who has just retired from the Rectorship of the Imperial College of Science and Technology. Sir George Beilby was similarly presented with the medal of the Institution of Mining Engineers in recognition of his contributions to science, with particular reference to his researches on fuel; both recipients had the honour of receiving the medals from the hands of the Prince of Wales. The speeches at the dinner were of a remarkably high order, and we offer our congratulations to all who were concerned in making arrangements for an event which not only maintained the dignity of applied science but also will contribute in no small measure to its continued development.

THE latest reports add little to our knowledge of the Chilean earthquake except to increase the estimates of the loss of life and of the destruction of property. The total number of deaths is for the present officially put at 1800, and that of the injured at more than two thousand. The town which seems to have suffered most is Vallenar, half-way between Coquimbo and Copiapo and about forty miles from the coast, where one out of every eight inhabitants was killed. Much of the damage, especially from Coquimbo to Chanaral (240 miles north of Coquimbo) was caused by the sea-waves. The early and clearly erroneous report that the depth of the sea near Copiapo had decreased from 2800 to 86 fathoms is

now contradicted. The greatest known uplift is less than 48 feet, in Alaska during the earthquakes of 1899. M. de Montessus de Ballore, who has studied the distribution of the Chilean earthquakes, defines several regions along the coast. The region of Atacama, Copiapo, and Coquimbo, to which the recent earthquake belongs, is one in which earthquakes are relatively frequent, though it is less often visited by destructive shocks than the regions of Arica and Iquique, and of Valparaiso, Santiago, and Concepcion. All three regions are situated in a district of unusually steep surface-gradient. Off Arica lies the Bartholomew deep (3500 fathoms), off Copiapo the Richards deep (4100 fathoms), and off Valparaiso the Haeckel deep (3000 fathoms). The origin of the recent earthquake may have been near the southern end of the Richards deep.

THE *Electrical Review* is to be congratulated on the issue of its jubilee number. It may well be proud of its record during the last fifty years. It has taken a broad view of its technical functions and has published many important papers in pure and applied science. This jubilee number is a particularly interesting one, as the articles are written more with an eye to the future than the past. Electricians regard a cheap unit of electricity as the most essential raw material for the country. There are endless duties which electric power can perform, not only in our homes and factories but on our railways and in mines. It is possible that the advent of the thermionic valve may lead to the scrapping of the telephone system of the country. Major Purves, the Engineer-in-Chief of the Post Office, looks forward to the possibility of an entire change in our methods of telegraphy. Telegrams can be despatched by the photographic means already shown to be feasible for the transmission of drawings and photographs. These messages would be charged by the area of the paper occupied by the telegram and not by the number of words. The received telegram would be a facsimile of the original and neither counting of words nor corrections would be required. Sending telegrams would be almost as simple as sending letters, and would be much quicker and less costly than at present. The advantages of electric heating are also emphasised. When this system is adopted chimneys in buildings can be dispensed with, fireplace furnishings will be unnecessary, and the inlet and outlet ventilators on the floor and ceiling of the room will give the occupant a better control over the air supply.

THE words "Leaf Pictures" recall the ingenious arrangements of pressed seaweeds, shells, and the like still to be found adorning the walls of modest dwellings in the country. The work exhibited by Mr. W. J. King at 118 New Bond Street is of a very different order, and challenges the attention alike of the man of science and the lover of art. As the botanist turns from the plant materials employed to the finished product, he cannot but marvel at the delicacy of perception required in the selection of the

former and the degree of technical skill shown in elaborating an entirely original technique. Some of the work dates from twenty years back and suggests problems to the plant physiologist on the stability of vegetable pigments in relation to light and other external conditions. Seen at a little distance, the pictures might be mistaken for oil paintings. Actually, the medium consists of plant material—leaves, petals, and other tissues—selected with much skill and exposed to bright sunshine after drying. The material so prepared is treated as would be the colours on a palette, and by its use in this way Mr. King has achieved remarkable results. The "Dante bust" (Naples) and the "Virgin" (after Bernardino Luini) afford proof of the technical skill of the craftsman. The original works, especially the landscapes entitled "Spring," "Beech Trees in Autumn," and others, provide evidence of real artistic ability as well as mastery of a most remarkable plastic medium.

DR. GRAVELY, the superintendent, seems determined to make the Government Museum, Madras, used by the local schools. He has attached the scientific and popular names in various vernaculars to the trees in the compound; he has started a herbarium of the flora of Madras city, also with vernacular names, as a guide and ensample to the schools; he has had a research student of the University of Madras working on the local fauna with special reference to groups likely to be useful for nature study (bugs are specially mentioned); and he has arranged for demonstrations both to teachers and to students. Alas! Madras does not respond as it ought: one out of the four demonstrations to teachers failed because no teachers turned up, and of the 2221 anticipated students only 950 attended. But Dr. Gravelly goes on collecting the local specimens, and his sub-librarian has at any rate found matter for a chapter on "Museums and Libraries" contributed to a work on "Teaching in Indian Elementary Schools." All of which and much more we learn from the Report entitled G.O. No. 885.

DR. J. C. WILLIS has published in the *Nineteenth Century* for October a statement of his hypothesis of "Age and Area," in its bearing on the evolution of species. It will be remembered that the subject was introduced by him at the recent meeting in Hull of the British Association, where it met with somewhat severe criticism. In the present article the author avers that Darwin's theory of natural selection "has received so severe a shake that it is no longer a name to conjure with." It is unable, for example, to explain the distribution of the Ceylon species of the genus *Coleus* (nettle-geranium). The visible structural differences between the species of wide and those of restricted distribution cannot possibly make any difference of advantage or disadvantage to their possessor. The controlling principle, according to Dr. Willis, is that "widely-spread species are in general the oldest and first evolved, very local species the youngest and last evolved." Moreover, the area occupied by a group of genera corresponds roughly with the number of species in each genus of the

group. It follows that the number of species in a genus should also show an increase with its age. Opinions will differ as to the importance to be assigned to the factors suggested by Dr. Willis; it cannot, however, escape notice that while he alleges that it would be "wiser to abandon natural selection" as the general principle that has guided evolution, he yet allows that "nothing can come into lasting existence" without its permission.

THE opening remarks of Prof. C. H. Desch in his Stratfield Memorial Lecture delivered at Finsbury Technical College on November 2, on the subject of "The Metallurgical Chemist," emphasised the value of trained chemists in the field of metallurgical and chemical industry to control and guide these industries. Prof. Desch asserted that the basis of the training for a metallurgical chemist should be mathematics, physics, and chemistry, and specialised work should not be entered upon at too early a stage. Chemical knowledge and manipulative skill is required, for example, for the analysis of alloys and modern high-speed steels, while training in physical chemistry and physics is requisite for a proper interpretation of the results of examinations of physical properties, for example, of alloys as shown by X-ray analyses. There is also need for engineering knowledge for carrying out large-scale metallurgical operations, such as the study of fatigue and also in ore extraction. Probably the best results can be obtained by the co-operation of chemist and engineer both with a certain amount of training in common. Prof. Desch also referred to the importance to the metallurgical industries of further work on refractory materials. Another matter awaiting immediate attention is economy in the utilisation of fuel and other natural resources. Secrecy and rule-of-thumb methods have completely disappeared from the steel industry, and co-operation between the scientific advisers, to the advantage of the whole industry, has taken its place.

ON November 15, Prof. A. P. Laurie, professor of chemistry to the Royal Academy, delivered a lecture at the Academy on "The Preservation and Cleaning of Pictures." He pointed out that the question of the preservation and cleaning of pictures is not a purely scientific one, but involves certain æsthetic considerations, and he suggested that there has been some confusion of thought on the whole subject. A picture might have certain flakes of paint off it, and yet be otherwise in good condition, and in such a case it would probably be considered necessary to restore the absent pigment. Here, however, we get upon purely æsthetic ground as to whether such a restoration is justifiable. In order that the general appearance of the picture conveyed to the observer what the artist intended, it is necessary to replace the defective part, but from the point of view of the minute and careful student of the picture, it is essential that such replacement should be known. This difficulty can be overcome by taking photographs of the picture before repair, so as to put on record what is the work of the master and what is the work



of the restorer. While not prepared to give a final opinion as to the safest methods of cleaning, Prof. Laurie suggested that where alcohol is used castor-oil should be laid on the surface with a soft brush, and then a mixture of castor-oil and alcohol dabbed on with a soft brush, and removed by diluting with turpentine and sopping up with a large dry brush. Where alcohol is not a sufficiently powerful solvent copaiba balsam emulsified with ammonia might be used, a preparation of copaiba balsam thinned with a little turpentine being laid on the surface first. If any friction is to be applied it should be done with a soft rubber point, and at every stage examined under a powerful magnifying glass. No important public picture should be cleaned until it has been authorised by a committee of experts, and the cleaner himself should be present and explain exactly what he is going to do, while everything he does should be under the direct supervision of the head of the Public Gallery.

THE next Congress of the Royal Sanitary Institute will be held at Hull on July 30-August 4, 1923, by invitation of the Mayor and Town Council.

THE Huxley Memorial Lecture announced for delivery by Prof. M. Boule at the Royal Anthropological Institute on Tuesday, November 28, has been postponed through the ill-health of the lecturer and his consequent absence from this country.

APPLICATIONS are invited for the Government Grant for Scientific Investigations for the year 1923. They must be received at the offices of the Royal Society, Burlington House, Piccadilly, W.1, by, at latest, January 1, on forms obtainable from the clerk to the Government Grant Committee.

NOTICE is given by the Chemical Society that the latest date for the receipt of applications for grants from the Research Fund of the Society is Friday, December 1. The applications must be made upon forms obtainable from the Assistant Secretary, Chemical Society, Burlington House, W.1.

THE Hon. Sir Charles A. Parsons has consented to deliver the second Joule memorial lecture at the Manchester Literary and Philosophical Society's house on Tuesday, December 5, at 4 P.M. The title of the lecture will be "The Rise of Motive Power and the Work of Joule." The dinner, in honour of the lecturer, will be held the same evening at 7.30 P.M.

IN our obituary notice of Prof. Michie Smith (November 4, p. 610), the initiative in the establishment of the mountain observatory near Kodaikanal was ascribed to him. Mr. F. Fawcett writes that it was really due to his predecessor, Mr. W. Pogson, who had this project much at heart; but his premature death prevented him from seeing its realisation.

THE eleventh International Physiological Congress will be held in Edinburgh on July 23-27, 1923. The following officers for the meeting have been elected: President, Sir Edward Sharpey Schafer; treasurer, Prof. A. R. Cushny; secretaries, Prof. G. Barger and Prof. J. C. Meakins; assistant secretary, Miss

Dorothy Charlton. Further particulars can be obtained from the assistant secretary at the Department of Physiology, The University, Edinburgh.

At the annual general meeting of the London Mathematical Society on November 9, the following officers and members of council were elected:—*President*: Prof. W. H. Young; *Vice-Presidents*: Mr. A. L. Dixon, Prof. A. E. Jolliffe, and Mr. H. W. Richmond; *Treasurer*: Dr. A. E. Western; *Secretaries*: Prof. G. H. Hardy and Prof. G. N. Watson; *Other Members of Council*: Mr. J. E. Campbell, Prof. L. N. G. Filon, Prof. H. Hilton, Miss H. P. Hudson, Mr. J. A. Littlewood, Prof. A. E. H. Love, Mr. E. A. Milne, Mr. L. J. Mordell, and Mr. F. B. Pidduck.

A CONFERENCE in classical archæology will be held at Oxford, with the sanction of the committee for Classical Archæology, in the Ashmolean Museum, on January 9-16, 1923. There will be lectures, discussions, and demonstrations concerning Greek and Roman monuments and antiquities. The conference, which is intended mainly for those engaged in teaching, will take place only if a satisfactory number of applications for membership is received by the Hon. Secretary, Mr. Stanley Casson, New College, Oxford, before the end of this month.

By the will of Mr. W. H. Hudson, who died on August 18 last at the age of eighty years, the residue of his property, more than 7500*l.*, is bequeathed to the Royal Society for the Protection of Birds "to be used exclusively for the purpose of procuring and printing leaflets and short pamphlets suitable for the reading of children in village schools . . . each is to be illustrated with a coloured figure of a bird, the writing is to be not so much 'educative' or 'informative' as 'anecdotal.'"

THE Institution of Naval Architects is offering the following scholarships for competition in 1923:—In naval architecture—Martell (130*l.* per annum), Hawthorn Leslie (150*l.* per annum), Vickers (150*l.* per annum), John Samuel White (100*l.* per annum), Denny (75*l.* per annum); and in marine engineering—Richardson Westgarth (150*l.* per annum), Denny (75*l.* per annum). The scholarships are open to British apprentices or students, and are tenable for three years at the following institutions: the Universities of Glasgow, Durham (Armstrong College), and Liverpool, the Royal Naval College (Greenwich), and the City and Guilds (Engineering) College, London. Full particulars may be obtained from the Secretary, Institution of Naval Architects, 5 Adelphi Terrace, London, W.C.2.

THE October number of the Journal of the Royal Photographic Society is a special exhibition number. It includes the address given by Mr. Solomon J. Solomon when he opened the Society's exhibition, descriptive notices of the various sections, and reproductions of about thirty of the exhibits, several of which are from the natural history and scientific sections. It forms a distinctly valuable and interesting addition to the catalogue, which also contains several reproductions.

THE latest catalogue of second-hand books offered for sale by Mr. F. Edwards, 83 High Street, Marylebone, W.1, is No. 437 (November). It gives the titles, and in many cases descriptions, of upwards of 800 volumes on oriental matters, mainly Chinese and Japanese.

THE old-established firms of instrument-makers, T. Cooke and Sons, Ltd., of London, York, and Cape Town, and Troughton and Simms, Ltd., of London and Charlton, have amalgamated, and the joint business will be conducted under the name of Cooke, Troughton and Simms, Ltd.

WE have received from Messrs. A. Gallenkamp and Co., Ltd., of 19 and 21 Sun Street, Finsbury Square, London, E.C.2, Part I. of the seventh edition of their

catalogue of general chemical apparatus, including balances and weights. In addition to the ordinary requirements of the chemical laboratory, the catalogue includes some special features such as Mellor's porosity apparatus and a series of vacuum drying ovens.

THE "Collected Scientific Papers" by the late Dr. John Aitken, the final sheets of which were passed for press by Dr. C. G. Knott just before his death, will shortly be published by the Cambridge University Press. The volume will contain a biographical sketch of the author. "The Theory of Spectra and Atomic Constitutions," by Prof. Niels Bohr, will also be published by the Press in the near future. It is based on lectures delivered in Cambridge and deals with the application of the quantum theory to problems of atomic structure.

### Our Astronomical Column.

THE LEONID METEOR SHOWER.—Mr. W. F. Denning writes that "The nights of November 13 and 15 were alone suitable for observation at the period of the Leonid display this year, and very few meteors appeared. Mr. J. P. M. Prentice watched the heavens on the night of November 15 between 5.45 and 12.45 and recorded only 44 meteors during the seven hours, of which three were Leonids. At Bristol the sky was watched at a later hour, but only one Leonid was seen between 13<sup>h</sup> and 13<sup>h</sup> 45<sup>m</sup>, after which observations were discontinued. Mr. Prentice noticed several minor showers of which radiant points at 41°+29°, 42°+21°, 53°+13°, and 55°+84° were the most actively pronounced." The shower of Leonids was not expected to be abundant this year, as the parent comet (1866 I) will not return until 1933. It sometimes happens, however, that a moderately active display of Leonids occurs when the comet is far removed from perihelion, as in 1879 and 1888.

COMET NOTES.—Baade's Comet, 1922 c, was observed at Copenhagen on November 9 and at Cambridge by Mr. G. Merton, using the Northumberland Equatorial, on November 11. It has a fairly definite nucleus 10" to 20" in diameter, and a coma 1½' in diameter. The stellar magnitude is variously estimated at 9 and 10.5, the former being probably nearer the truth. The brightness is slowly diminishing, but the comet should be observable for some months. The following orbit is from observations on October 19, 28, November 11:—

$$\begin{aligned} T &= 1922 \text{ Oct. } 27^{\text{d}} 25^{\text{h}} \text{ G.M.T.} \\ \omega &= 118^{\circ} 46' 33'' \\ \Omega &= 220^{\circ} 34' 22'' \quad 1922.0. \\ i &= 51^{\circ} 23' 31'' \\ \log q &= 0.35318. \end{aligned}$$

#### EPHEMERIS FOR GREENWICH MIDNIGHT.

	R.A.		N. Decl.	log $\rho$ .	log $\Delta$ .	
	h.	m.	s.			
Nov. 25.	21	15	32	27° 20'	0.3579	0.3150
29.	21	25	36	26 20	0.3593	0.3222
Dec. 3.	21	35	39	25 21	0.3608	0.3297
7.	21	45	39	24 26	0.3625	0.3377
11.	21	55	35	23 33	0.3643	0.3460
15.	22	5	27	22 44	0.3663	0.3549

The comet is well placed in the evening sky, high up in the south-west; it is visible in moderate telescopes. The above path begins 3° S.E. of  $\delta$  Cygni, and ends 3° S. of  $\alpha$  Pegasi. It is important to observe it as long as possible, in order to detect any deviation from a parabola.

Mr. F. E. Seagrave has computed the two following orbits of Comet Pons-Winnecke from observations made respectively before and after perihelion passage in 1921:—

T = 1921 June 12 <sup>d</sup> 9165.	June 12 <sup>d</sup> 9276.
$\omega = 170^{\circ} 17' 18''$ .	$170^{\circ} 15' 56''$ .
$\Omega = 98^{\circ} 6' 29''$ .	$98^{\circ} 8' 19''$ .
$i = 18^{\circ} 54' 37''$ .	$18^{\circ} 56' 33''$ .
$\log q = 0.017372$ .	$0.017499$ .
$\mu = 592''.888$ .	$587''.184$ .
Period = 2185.9 days.	2207.1 days.

The next perihelion passage will be in June 1927. The conditions will be very similar to those in 1921, but the approach to the earth will probably be closer; search should again be made for meteors in that year, since these are evidently spread fairly widely around the comet's orbit. The perturbations in the present revolution are small, there being no approach to Jupiter.

REPORT OF THE PARIS OBSERVATORY FOR 1921.—This report shows that in spite of difficulties caused by the war there is quite a large output of work. The observations for three important star catalogues have been completed, namely, (1) the supplementary catalogue of Lalande stars; (2) that of 15,000 *étoiles de repère* of the Paris zone; (3) that of 3000 fundamental stars; they will be published in a few years. The work on the Astrographic Chart is approaching completion; the 2500 copper plates, 26 × 26 mm., will be carefully stored, as it is suggested that they may form a priceless record of the state of the heavens in an age long after the paper copies have perished. It is hoped that the Paris Astrographic Catalogue will be completed in four or five years.

It is noted that M. Krassowski of Varsovie has undertaken the calculation of the perturbations of Giacobini's Comet 1896 V which is expected early next year.

Full details are given of the system of Time signals, which are under the direction of M. Bigourdan. M. Hamy has been investigating the diffraction of the images of stars and hopes to apply his results to obtain an improved diameter of the sun.

Photography of stars by the extreme red rays has been carried out experimentally, and it is proposed to continue this work on Mont Blanc. The aim is to study the possibilities of daylight star photography. The report also deals with spectroscopic work on bright stars, the sun and chromosphere, and several stars have been photographed in three colours with colour screens.

## Research Items.

**POTTERY-MAKING ON THE BLUE NILE.**—In *Sudan Notes and Records*, April-July, 1922, Mr. H. A. MacMichael contributes a report, illustrated by sketches, of pottery-making on the Blue Nile. The vessels of which the manufacture is described are the *Burma* or pots for carrying and storing water, and the water-jars used for the *Sagias* or water-wheels. The implements used are a roughly smoothed lump of stone the size and shape of a penny bun, and an oblong, slightly concave, river shell, which, if unobtainable, can be replaced by a fragment of dry water-melon husk. With these the lump of clay is kneaded with donkey's dung, is beaten into shape, and smoothed. The industry of making the *Sagia* jars is not originally found in the Sudan, but is rather Nubian and riverain.

**IMMIGRANT GROUPS IN AMERICA.**—In the *Scientific Monthly* for November, Prof. Kimball Young discusses the results of applying intelligence tests to various immigrant groups in America. He points out that whereas up to the year 1882 the highest percentage of immigrants came from the British Isles and Northern and Western Europe, of recent years a complete change has taken place, the highest percentage now being from Southern and Eastern Europe. This change, he considers, is of the greatest importance for the future of America. If the more recent additions to America are of a less intelligent stock than the earlier inhabitants, then the consequences will be serious for the future. In order to test intelligence, the writer used the already well-known American Army tests, modified to suit the children he was testing, and he also considered the work of others studying racial differences by like methods. As a result of a very careful study he brings forward evidence to show that the intelligence of these Southern European stocks is very much lower than that of the other stocks. If that is so, then the continued dilution of the original, more intelligent, stocks by these inferior ones will seriously affect the average intelligence of the population of the country. As a practical deduction, it is urged that there must be a complete change in public opinion on the desirability of large numbers of immigrants; and secondly, that immigration must be controlled in the interests of the national welfare, new-comers not being allowed to enter unless they can read a certain standard in intelligence tests.

**NEW ANTARCTIC BRITTLE-STARS.**—The Ophiroids collected by the Australasian Antarctic Expedition (1911-1914), under the leadership of Sir Douglas Mawson, are the subject of a memoir by Prof. R. Koehler, of Lyons, illustrated by 15 quarto plates, crowded (indeed over-crowded) with excellent photographs by the author (Sydney: John Spence. Price 10s. 8d.). There are 37 species, of which 19 are new, and three of the latter serve as types of three new genera—Ophioparte and Ophiodaces among the Ophiacanthidae, and Ophioceres, which is intermediate between Ophioplepis and Ophioplocus in the Ophiopelidiidae. Ophiopripa also appears to be a new generic name, unless, indeed, Prof. Koehler's report on the Ophiroids collected off the Philippines by the *Albatross* was published before this one. Some nine species previously known from the Antarctic or sub-Antarctic have their horizontal and bathymetric limits considerably extended. *Asteronyx loveni* and *Homalophiura irrorata*, being now found in the Antarctic, may claim to be absolutely cosmopolitan species. The latter was dredged at a depth of 1800 fathoms along

with a new *Astrodia* and *Ophiomusium planum*, which last was previously known from great depths in the Atlantic and Indian Oceans. When so much is added to our knowledge from only fourteen stations, we realise how much there must be still to learn. We may, however, hope that the number of recent ophiroid genera will not be greatly increased.

**"INSULIN" AND THE OXIDATION OF SUGAR.**—The experiments of Von Mehring and Minkovski in 1889 showed that in the absence of the "Islets of Langerhans" of the pancreas, sugar was imperfectly utilised by dogs, thus leading to the condition known as diabetes mellitus. An internal secretion was naturally supposed to be responsible, but extracts of the pancreas were found to have little or no capacity of replacing the islet tissue. It seems that some constituent of the whole pancreas, perhaps trypsin, destroys the internal secretion. It occurred to Dr. Banting of London, Ontario, that if use were made of glands in which the ordinary secreting tissue had degenerated as a result of tying the duct, this destruction might not occur. Accordingly, arrangements were made by which Banting, in conjunction with a group of workers in Prof. Macleod's laboratory at Toronto, investigated the question. The results have been published in a series of papers in the *Trans. Roy. Soc. of Canada*, the *Amer. Journ. of Physiology*, and elsewhere, under the names of Banting, Best, Macleod, Collip, and others. Active extracts were obtained in the way mentioned, and finally a method was discovered by which they could be got from ordinary pancreas, by the use of alcohol, in a form suitable for hypodermic injection. The preparation has been named "insulin." It has the properties of increasing the consumption of sugar by the tissues and indirectly that of fat, which is incompletely burned in the absence of the oxidation of sugar. The concentration of sugar in the blood, both of normal and of diabetic animals, is thus reduced. That it is burned is shown by the rise of the ratio between the carbon dioxide expired and the oxygen taken in, as also by direct experiments on the excised heart. The toxic effects of the products of incomplete oxidation of fat disappear. An important new fact is that the blood sugar of normal animals can be reduced to a low level, and when this is reached various abnormal symptoms appear, especially in the nervous system. In the rabbit, attacks of convulsions finally lead to death. All these results can be abolished immediately by giving glucose. Insulin is also effective in diabetes in man, but repeated injections are necessary since the effect of one dose lasts only about twelve hours, and each individual dose must not be so large as to bring about the low level of blood sugar above mentioned.

**VISIBILITY AS A SIGN OF COMING RAIN.**—Exceptional visibility as a sign of coming rain is discussed in the *Meteorological Magazine* for October from observations made by Mr. W. H. Pick of the Meteorological Office, Air Ministry, at Cranwell, Lincoln. Observations were taken on 518 days from April 1, 1920, to August 31, 1921. Visibility is observed hourly, and the classification of a day with visibility of 21 miles or more is a day on which such visibility was observed at one or more of the hours from 9 h. to 17 h., and similarly with a visibility of 13 miles, the latter being naturally included in the visibility of 21 miles or more. The days with rain between the period of visibility and 7 h. on the following morning are also tabulated. An examination of the data is said to show that, so far as Cranwell is concerned,

there is no evidence that a day of exceptional visibility is more likely to be followed by rain than a day of low visibility; the author says, rather the reverse. Only one-third of the days with visibility 21 miles or more were followed by rain, while with visibility less than 13 miles one-half of the days were followed by rain. A discussion on visibility at a meeting of the Royal Meteorological Society last December has helped much to an understanding of the subject. Exceptional visibility or "nearness" is by no means a common feature, and for a test as a sign of coming rain, it seems to require different handling from that given by the author.

**WEATHER IN KOREA.**—The annual reports of the meteorological observatory of the Governor-General of Chosen for the years 1918 and 1919 have recently been received. They give hourly meteorological observations at *linsen* (*Chimulpo*) mostly from European self-recording instruments, and also daily means and extremes. At fourteen branch-stations the several meteorological means are given for each 4 hours for each month and for the year. For several auxiliary stations the mean highest, mean lowest, and mean temperatures are given, as well as the amount of precipitation and days with rainfall, also the maximum precipitation in a day at each station for each month, and the dates of first and last frost and first and last snowfall. There is great variation of temperature and rainfall at the different stations and at different seasons consequent on the varying heights of the stations and the vastly different exposures, the country being generally very mountainous. The auxiliary stations supplying data for the climatological investigation of the peninsula numbered 203 at the end of 1919. With the object of securing data for the investigation of thunderstorms four hundred head masters of the ordinary Korean schools report all the phenomena which accompany the storms, and this will be continued for three years from 1918, confining the reports to the warm season from April to September. The continuity of these observations, year after year, adds greatly to the general knowledge of the world's meteorology. Magnetic observations, which formed part of the ordinary routine, have for the time been suspended owing to the destruction of the quarters by a severe storm in September 1919.

**THE ROCKY MOUNTAIN OIL-FIELD.**—New information concerning oil possibilities of the great Rocky Mountain Field of North America is always of interest, and particularly so in connexion with Montana, which, compared with the adjacent State of Wyoming, has up to the present yielded surprisingly poor results. Stratigraphically and structurally there is much territory in Montana which should prove favourable, though large areas are at present unprospected for oil and gas. Mr. W. T. Thom, Jr., in a brief report published recently, has thrown much light on at least one interesting district, that of the Crow Indian Reservation, in Big Horn and Yellowstone counties, the southern part of the State. Some 3000 square miles of this Reservation, lying to the north and east of the Big Horn-Pryor Mountain uplift (forming the dominant regional structure), offer the best prospects, and within this area a local uplift known as the Soap Creek Dome is being developed; most of the oil obtained has been won from the *Amsden* formation, a shale-and-sand series of Pennsylvanian age. The underlying Madison Limestone—a particularly pure limestone of Mississippian age and well developed in central and southern Montana—has also yielded oil at Soap Creek. Although no mention is made of the quality of the oil obtained during develop-

ments, it may be stated that great variation in gravity is the general characteristic of the petroleum obtained in southern Montana and northern Wyoming; such variation is dependent largely on the different geological horizons from which the oil is drawn, and in many instances, owing to the complexity of structure and widespread faulting, the nature of the oil changes with almost surprising rapidity from well to well. The future of the whole Rocky Mountain Field as regards oil production centres largely in the States of Wyoming, Colorado, and Montana, and although up to the present Wyoming has produced more than 90 per cent. of the oil obtained, the prospects for the other two States are by no means discouraging, as the present Crow Reservation bulletin reveals.

**GRAIN SIZE IN PHOTOGRAPHIC EMULSIONS.**—The nature of the developable image, the cause of sensitiveness, the relation between the size of the particles in a photographic emulsion and its sensitiveness, and other allied problems, have received a great deal of attention at the hands of several investigators during the last few years. This work has led to various hypotheses, which have been noted from time to time in our columns, all of which have not been generally accepted. Messrs. E. P. Wightman, A. P. H. Trivelli, and S. E. Sheppard, of the Research Laboratory of the Eastman Kodak Company, publish the first of a series of papers entitled "Studies in Photographic Sensitivity" in the October number of the *Journal of the Franklin Institute*, in which they propose to examine these hypotheses, to note wherein they lead to similar conclusions, and so far as possible to test experimentally between them. The present paper is on the distribution of sensitivity and size of grain in photographic emulsions. The authors discuss the existence and nature of statistical variation of sensitivity among silver halide grains, and the relation of this variation to the density-exposure function. It is concluded that under certain conditions the first derivative of the density-exposure function will correspond with the intensity-variation function or curve. The results of experimental determinations of grain-size-frequency curves are noted, and correlated with sensitometric data. The decisive influence of the grain-size distribution and limits on the "speed" and other sensitometric variables is discussed in relation to the "quantum" and the "photocatalytic" theories of grain sensitiveness.

**"ELECTRETS," THE ANALOGUES OF MAGNETS.**—For the last three years Prof. Honda and his pupils at the University of Sendai have been investigating the conditions under which rods of solid dielectrics permanently charged with positive electricity at one end and with negative at the other could be produced. In the most recent work of Mr. M. Satō, described in the June issue of the *Science Reports of the University*, a tube containing a molten dielectric has electrodes at its ends connected respectively to the positive and negative terminals of an electrical machine. The dielectric is allowed to solidify slowly from each end, the middle portion remaining liquid longest, and when the rod of solid dielectric is extracted from the tube, it is found to be charged positively at one end and negatively at the other, and the charges will continue apparently for years. If the rod is cut into short lengths each length is permanently charged, the amount of the charge being proportional to the distance of the length from the middle of the rod. According to Mr. Satō, these "electrets" are due to the ions held in fixed positions by the solidification of the dielectric.

## The International Geological Congress of 1922.

THE publication of the complete "Livret-Guide des Excursions en Belgique" and "Résumés des Communications Annoncées" affords us an opportunity of reviewing the work of the first International Geological Congress which has met since the war.

There are few countries that are so eminently adapted for a geological gathering as Belgium. With the exception of strata of pre-Cambrian age, all the formations are adequately represented within an easy railway journey from the capital. The rocks are well exposed on the sides of the deeply-cut river valleys and in the numerous quarries for limestone and sandstone, which are being actively worked for building material and road metal, and valuable information has been afforded by the coal mines and borings for coal. There has accordingly been every facility for the investigation of the geological structure, which is of the greatest interest. The area was subjected to great movements from the south in connexion with both the "Caledonian" and "Hercynian" epochs of disturbance in the earth's crust. The latter, which took place at the close of the Carboniferous Period, resulted not only in numerous well-marked folds but in extensive thrusts (*charriages*) from the south which brought older strata over those of younger age, in the same manner as ancient crystalline rocks were forced over Cambrian strata in the north-west highlands of Scotland during the Caledonian movements.

The very full and clear development of Devonian and Carboniferous strata and the careful work of the Belgian geologists upon them render a visit to Belgium peculiarly instructive to students of those formations in this country and throughout the world. The succession, too, of the Tertiary rocks of Belgium is also remarkably complete, and many of our British geologists welcomed the opportunity of familiarising themselves with them.

Nothing could exceed the efficiency with which the congress was organised, and this reflects the greatest credit on M. Arnaud Renier, the General Secretary, and his co-workers.

In one respect the congress presented a remarkable contrast to scientific gatherings in this country. Every member was permitted in all his railway journeys in connexion with the congress to travel at half the usual rates, whereas the members of the British Association know to their cost that since the war the railway companies have refused to abate a penny of their fares to those who take part in the annual meetings.

Excursions were carried out before, during, and

after the meeting at Brussels. Those before the congress lasted from six to nine days, and comprised traverses from south to north in the east of Belgium (M. Fourmarier) and in the centre (MM. Kaisin, Mailloux, and Asselbergh), and a special study of the metamorphic regions of Veilsalm and Bastogne (M. Lohest) and also of the Tertiary rocks (M. Leriche). The excursions after the congress included studies of the Cretaceous and Tertiary rocks of the neighbourhood of Mons (M. Cornet) and of the Carboniferous strata (MM. Lohest, Kaisin, and Renier), while M. Fourmarier devoted a fortnight to a detailed survey of the remarkable tectonics of the Palaeozoic rocks. The "Livret-Guide" to these excursions remains as an invaluable work of reference on the geology of the country.

The formal opening of the congress took place on August 10 in the presence of His Majesty the King of the Belgians, and M. Jean Lebacqz was elected president. Two or three sessions were held simultaneously and numerous important papers were read. A large number of these dealt with the character of the Hercynian disturbances in different areas, and they constitute important contributions to the literature of the subject, but much still remains to be done in correlating these movements and determining how far they were contemporaneous or successive in adjoining regions.

A noteworthy feature of the congress was the presence for the first time of representatives from Poland, Czechoslovakia, and Yugoslavia. No invitation was extended to the Central powers, which were on this occasion unrepresented. A proposal, which originated with MM. De Margerie and Lacroix, to prepare an international geological map of Africa, was welcomed by the representatives of the other powers having interests in that continent, and they agreed to co-operate in the undertaking.

It was proposed by Señor Rubio-y-Muñoz, the principal representative of Spain, that the next congress should take place in Madrid, and an attractive programme of excursions was promised. This was unanimously accepted. The question was raised as to whether the congress should continue on the lines which had hitherto been followed or should be transformed into an International Union of Geology affiliated to the International Research Council. There was a strong feeling in favour of the former course, and a constitution was adopted which will, it is believed, ensure the preservation of the past traditions of the congress as a great reunion of fellow-workers in geology in which all nations are represented.

J. W. E.

## Education, Research, and Invention.

IT is natural to find that a large portion of the presidential address delivered before the Institution of Mechanical Engineers by Prof. H. S. Hele-Shaw on October 20 should deal with education, research, and scientific knowledge and invention, in all of which the president himself has played an important part. The Institution has now before it the results of the first year's work in the examinations for national certificates and diplomas. These examinations are conducted by the technical schools, together with assessors appointed by the Institution, who are responsible for considering all papers and for reviewing and supervising all results. All the results are submitted to a joint committee of the council of the Institution and the Board of Educa-

tion, and all border-line cases are specially considered. It is of interest to note that in more than one case the Institution has had to modify the severity of the school, which is far more satisfactory than if technical schools desired to pass their candidates too easily. Of the 1250 candidates drawn from forty-eight technical schools, fifty-one per cent. have been awarded various grades of national certificates and diplomas. The Institution does not appear as yet to be ready to give a decision as to whether these examinations will be accepted in lieu of the Institution's own examinations for associate membership, although the matter appears to be under consideration.

It is now nearly fifty years since the Institution appointed its first research committee; since then

the sum of between 13,000*l.* and 14,000*l.* has been expended in research. There is no doubt that this policy has greatly enhanced the reputation of the Institution and has been of the utmost value to the engineering world. The time has arrived when the relation of the Institution to the National Physical Laboratory and the Government Department of Scientific and Industrial Research must be carefully considered. In view of present-day demands on the Institution and its members in all parts of the world, the council must consider to what extent, if any, it will be able to contribute in future to researches which may well be left in the hands of the above-mentioned bodies. The Institution is closely associated with both bodies through several members of council, and these will continue, as in the past, to give freely their services and experience. There is also a feeling that the Institution should not encroach upon the ground which newer and special Institutions are better qualified to undertake.

Prof. Hele-Shaw has long been known for his interest in inventions, and his remarks on inventions and inventors are of value. All progress, at any rate in mechanical science, must be in the nature of invention. Every step taken in which new ground is trodden, every new device or new mechanism, or new-machine of changed form, in which the movements of parts differ, or even if the object attained is different, can result only from the exercise of the inventive faculty. If a man cannot do more than alter the dimensions of the machinery which he is constructing, he cannot be called an engineer at all. Even where it is necessary to duplicate indefinitely any existing machine or machine part,

invention is required, and has in recent years been exercised in a wonderful way for production purposes.

The present stress of competition necessitates the more intense application of the inventive faculty, and an average of 30,000 patents is taken out each year by inventors searching for new devices and new results. It is easy to see what a hopeless task is being attempted by the ignorant and uneducated inventor. In one case he is probably attempting to discover something well known; in the other he lacks the education which would prevent him from attempting the hopeless task of trying to produce the impossible. Any one who studies the *Patent Journal* week by week must see that even to-day the attempts of a large number of inventors would be ludicrous if they were not in most cases pathetic. The truth, however, must be told—engineers in practice in the course of their work constantly spend large sums of money on inventions which, if they are more plausible, are not less impossible than those above mentioned.

Prof. Hele-Shaw has long thought that, beyond general engineering training, the time has come for an actual chair of invention. He hopes to see such a chair founded somewhere, and that a professor of invention may give lectures (one or more a year) to engineering students of different schools throughout the country. This would enable the principles on which success depends to be placed before rising engineers, as well as the methods of obtaining information on what had been already achieved in any subject, the cause of failure in previous attempts, and how to approach new problems so as to avoid falling into endless repetitions of previous workers.

### The Life History of the Eel.

THE complete story of the breeding of the European eel has now been told by Dr. Johs. Schmidt in a memoir published by the Royal Society (*Phil. Trans. B*, vol. 211, pp. 179-208, plates 17, 18, April 4, 1922). The publication will become a classic of science, not only because of its literary charm and the results that it sets forth, but as a record of the resolution of a man of science determined to carry his investigation to a satisfactory conclusion.

In May 1904 Dr. Schmidt, while working on fishery research on board the Danish Fishery vessel *Thor* west of the Faroes, found a *Leptocephalus* larva of 7½ cm. in length. "With little idea, at that time, of the extraordinary difficulties" of the investigation, he began his research. From then till 1910 he made what use he could of the *Thor*, but the vessel was too small. He obtained collections made by the *Michael Sars* and others stored in Danish museums, but the material was very inadequate. Then he persuaded various Danish shipping companies to help, and the skippers were supplied with nets and instructions. One ship-of-war also assisted. In 1913 a Copenhagen company allowed him the use of the *Margrethe*, and for five months all went well. Then the *Margrethe* was wrecked on a West Indian island, "but the collections fortunately were saved"! In 1914 and 1915 the United States Fishery vessel *Bache* and two Danish traders obtained plankton samples, and then the war stopped all further collecting till 1920. Finally, a Copenhagen company gave Dr. Schmidt the use of the *Dana*, and with the experience gained, abundant collections were made in 1920 and 1921. It was then, "with mingled feelings," that he found that the rich material included two species of eels, the American and European. These could only be separated by laborious countings of the myotomes and pigment spots, and all this had to

be done aboard ship immediately after the fishing operation.

The outcome of all these difficulties is the almost complete story of the European eel. For a period of five to twenty years, according to sex, climate, and quantity of food, the eel remains in fresh water. It is yellow-green in colour and without metallic lustre. Then the desire for food fails; the migratory instinct awakens; the silvery "bridal dress" is assumed, and the eels descend to the sea. This is the last that is seen of them, and the period of their migration is unknown. Sometime during the spring or summer, however, they spawn, in deep water, in the West Atlantic between about 22° and 30° N. lat. and 50° and 65° W. long. (roughly in the middle of the Sargasso Sea). The smallest larvæ caught are about 7 to 15 mm. in length, and they are found at about 200 to 300 metres from the surface. From then onwards their area of distribution widens. They rise to near the surface of the sea and begin to migrate to the north-east. In the first summer they are about 25 mm. long, and are found west of 50° W. long. In the second summer they are 50 to 55 mm. long, and they then inhabit the central Atlantic. In the third summer they are about 75 mm. long, and can now be found on the European coastal banks. They are still leaf-shaped, transparent *Leptocephali*, but in the autumn they undergo metamorphosis and enter the rivers as the cylindrical, smoky-brown eelers, about three years in age. The further history is well known: they may ascend rivers to a height of 3000 feet above sea-level (in Switzerland). Growth proceeds, and some five to twenty years later the seaward migration occurs. The story is unique in natural history, not only for its own interest, but also because of the patience and resolution with which it has been elucidated. J. J.



distinguished candidate is available, for research in any branch of chemistry, pure or applied, and no restrictions will be placed upon the manner in which the prize is utilised by the recipient. The donors of the fund, explained Sir George Beilby, hope that the prize will do something to stimulate young research chemists to greater effort, form a not unworthy tribute to the memory of Col. Harrison, and serve to remind the chemists of the future how their science was employed in the cause of right and humanity.

Sir James Walker, president of the Chemical Society, in a brief speech accepted the fund and trust deeds, and the custody of the permanent memorial. Before unveiling the latter, Earl Crawford referred with sympathetic insight to the work of Col. Harrison during the war, and to the loss suffered by the country in the death of Harrison and the remaining Fellows of the Society whose

names are inscribed upon the memorial. He expressed the hope and belief that the prize fund would fulfil the desire of the donors to encourage the younger chemists in research, a purpose which Harrison had ever in his thoughts. The unveiling of the memorial was marked by the sounding of the "Last Post"; after a minute's silence the "Reveille" concluded a simple and dignified ceremony.

The permanent memorial (Fig. 1) is the work of Mr. Ernest Gillick; it is of singular beauty. The bronze medallion bears an appropriate representation of a trench scene at the moment of a gas alarm. It is set upon marble, the natural colour of which harmonises with the bronze. In the rooms of the Chemical Society the memorial finds a most fitting home, and it is satisfactory to know that, should the Society change its quarters, it will be possible to transfer the memorial to the new rooms. C. R. Y.

### Long Distance Telephony.

MR. F. GILL, the "European Engineer-in-Chief" of the Western Electric Co., chose the subject of telephony over long distances, with special reference to the international problems of communication between the various countries of Europe, in his presidential address to the Institution of Electrical Engineers delivered on November 2. Incidentally he pointed out that the passive attitude of a Government, content to satisfy the public demand only, would never lead to an efficient service. The success of the "Bell-owned" companies in the United States is due to an intensive educational campaign coupled with construction well in advance of the demand. In the United States the number of telephone stations has been increased ninefold during the last twenty years, and there is now one telephone station to every 7.7 persons. In Mr. Gill's opinion a Government Department should earn something more than merely sufficient to pay its way. If this were done there would be no difficulty in getting the capital necessary to extend the business. With a large staff it is disastrous that the idea should prevail that profit-earning is of no account.

Mr. Gill stated that the "carrier" system has greatly increased the maximum load possible on given lines. In this system carrier waves of frequency between 4000 and 27,000 per second are used, and by means of "wave filters" they can be separated into different circuits without difficulty.

On the New York-San Francisco line there are four conductors which form simultaneously two physical, one phantom, and four earthed telephone circuits. They also form part of a varying number of telegraph circuits ranging from six to twenty. The introduction of the thermionic repeater in 1914 gave a great impetus to telephonic development. As many as 23 of these repeaters have been used in tandem without seriously distorting speech. Mr. Gill gave data to prove that the telephone system of the United States is in advance of European systems.

In conclusion Mr. Gill discussed the problem of improving the through telephonic system of Europe. In Europe there is no organisation to co-ordinate the forty local systems. If a line were constructed between London and Christiania it would probably traverse six intermediate countries. The direct distance between London and Bagdad is about the same as that between New York and San Francisco, between which daily conversations take place. Under present conditions through telephony in Europe can be of little value. Mr. Gill then suggested alternative schemes for international control and urged that every endeavour should be made to secure it. The telephone authorities of Europe should hold a conference to try to find a solution, for to be interested jointly in a flourishing telephone undertaking would increase goodwill among nations.

### Low Temperature Carbonisation.<sup>1</sup>

By Prof. JOHN W. COBB.

THE report of the Fuel Research Board for the years 1920-21 on "Low Temperature Carbonisation" has been awaited with interest in many quarters because the subject has been much debated, and it was known that experiments were being carried out by Sir George Beilby and his staff at the Greenwich experimental station. On one hand, the process has been spoken of in terms of unrestricted enthusiasm and optimism as providing a simple and general solution of the smoke problem through the smokeless solid fuel which was to be produced, and as yielding large supplies of liquid fuel for naval and other purposes through its promised high yields of tar. On the other hand, critics of the process have indicated some shortcomings. The gas yield is small, and the process of carbonisation as carried on at higher temperatures in the gasworks is paid for

mainly by the large volume of gas which can carry a much higher price per thermal unit than a solid fuel because each thermal unit is worth so much more in use. Again, one of the principal by-products of carbonisation—ammonia—can be obtained only in comparatively small quantity by low temperature carbonisation, and the tars are much less valuable by current standards than those produced at higher temperatures because they lack aromatic constituents and are deficient in some other respects.

Sir George Beilby, who signs this report, has approached the investigation in an entirely sympathetic spirit. As a matter of fact, he was busy with the subject before it excited the amount of interest which is now bestowed upon it, and in this report he has detailed not only the results of experiments carried out by the Fuel Research Board, but reviewed the work of other investigators.

In a preliminary review of the situation, Sir George Beilby points out that broadly speaking this country

<sup>1</sup> Department of Scientific and Industrial Research. Report of the Fuel Research Board for the Years 1920, 1921. Second Section: Low Temperature Carbonisation. Pp. iv+73+8 plates. (London: H.M. Stationery Office, 1922.) 2s. net.



has to depend on overseas sources for its supply of fuel oil of all kinds, but that the market for fuel oils is not trustworthy commercially, the price having fallen from more than 15s. per ton to from 3s.-4s. during the past eighteen months. "The bearing of this fall in price upon schemes for the low temperature carbonisation of coal will be at once appreciated when it is stated that it represented a drop of at least 10s. on the value of the fuel oil obtainable by carbonisation from 1 ton of coal." At the same time, it must be remembered that in low temperature carbonisation, fuel oils and gas only amount to about 6 to 9 per cent. respectively of the products, 70 per cent. being coke, and the opinion is expressed that the profitable working of the low temperature process must depend largely upon a recognition of the superiority of low temperature coke to raw coal as a fuel, which takes the practical form of willingness to pay a higher price for it. If that were secured so that the process could be adopted by gasworks, it is suggested that the rich gas produced in the process could be brought into use as an enriching agent for the raising of low grade gas made in other ways to a higher standard of calorific value. Plainly, however, any wide adoption of the process would depend upon the difference in price between the solid smokeless fuel and raw coal being small, and the position is summarised thus: "This process as an industrial operation will stand or fall on a perfectly definite issue which is whether or not it is possible to evolve an apparatus on sound engineering lines in which the capital and working costs would fall within the modest margin of working profit on which the industry must be founded."

The working out of any such process in its best form depends upon a thorough knowledge of the changes which coal, or rather coals, of different kinds undergo in the process of carbonisation, and the report deals with work on this subject. It includes interesting results which have been obtained in a study of the microstructure of cokes produced from different coals in different ways, and emphasises the value which attaches to the proper blending of coals for the carbonisation process as influencing their behaviour in the carbonisation process, and the quality of coke which can be produced from them. The work has, however, gone beyond the laboratory

stage, and experimental apparatus has been devised and worked in which the peculiarities of the low temperature process for good or evil have been brought out. The following results can be taken as typical of those obtained by low temperature carbonisation in horizontal retorts:

YIELDS AT 600° C. PER TON OF COAL (DRY)	
Coke . . . . .	14.5 to 15.5 cwts.
Crude oil . . . . .	13.0 to 17.0 gallons.
Liquor . . . . .	7.0 to 15.0 gallons.
Ammonium sulphate . . . . .	4.5 to 8.5 lbs.
Gas . . . . .	3000 to 3500 cub. ft. = 27 to 35 therms.

The coke is a smokeless solid fuel, the smoke-yielding constituents having been expelled. The gas is in small quantity but rich. The ammonia yield is very small, about one-quarter of what is usual in gasworks practice. The crude oil is some 50 per cent., greater in volume than would occur in ordinary gasworks practice. Its flash point was atmospheric, and when the light spirit was removed from it so as to give a fairly satisfactory flash point the oil was sufficiently fluid to meet the Admiralty specification at 15° C., but at 0° C. was much too viscous. The crude oil had a limited miscibility in mineral fuel oils—a grave practical shortcoming. The behaviour of the metal retorts used in this carbonisation was satisfactory in the sense that they showed no sign of distortion or depreciation after using for nearly two years, but the behaviour of steel in the moving parts of an automatic carbonising machine which was tried was not equally satisfactory, defects being encountered due to the loss of rigidity which occurs in steel at a temperature of 600° C. A number of points requiring further investigation have arisen, and the work now in hand includes the development of automatic methods of carbonisation, the study of briquetting as a preliminary to carbonisation, and the development of a practical method of briquetting at or near the fusing point of the coal. It is along some such lines that it is hoped to arrive at some form of process and appliance for low temperature carbonisation which will meet the technical and commercial demands which have to be satisfied if this method of dealing with coal is to find wide application.

### Expedition to Chinese Tibet.

AS already announced, the Percy Sladen Trust Expedition to the Alps of Chinese Tibet, consisting of Prof. J. W. Gregory and his son, Mr. C. J. Gregory, has returned after a successful journey. The primary object of the expedition was the investigation of the geological structure of the mountain regions of China in localities which would throw light on the relations of the mountains of south-western China to those of the Himalaya and south-eastern Asia. The expedition left Bhamo on the Irrawadi in North Burma on May 7, and crossed the frontier hills to the "Treaty Port" of Tengyueh, where the Indian servants were sent back and a Chinese staff and muleteers engaged. Permission was there given by the Chinese magistrate to go to Likiang-fu, the administrative headquarters on the borders of Chinese Tibet. The expedition was allowed to proceed to Likiang-fu by a route across one of the blank areas on the existing map of Yunnan.

At Likiang-fu it was found that orders had been received from the capital of the province that the expedition was not to be allowed to go farther north; but the magistrate ultimately agreed to its going on if he were relieved of personal responsibility by a letter stating that the expedition was proceeding at its own risk, and in spite of his warning. From

Likiang-fu it travelled through the valleys of the Yangtze-kiang and the Mekong. Work in the upper Salween valley was found to be impossible, as it was reached in a district smitten with famine owing to the excessive rains of the previous autumn. The return journey to the caravan, which had been left to proceed north along the eastern side of the Mekong, was by forced marches on short rations. At Atuntze excursions were made to the higher mountains between the Mekong and the Yangtze-kiang and to the glaciers of Pei-ma-shan. The return route was through Likiang-fu to the city of Tali-fu and thence by the main trade route across Yunnan to the starting-point at Bhamo.

The geological collections will, it is hoped, be worked out during the winter, and the results of the expedition can now be judged only by the field evidence. It indicates that while the structure of the foundation of the country is due to the Hercynian movements of upper Palæozoic date, the area has been affected by a series of uplifts which, both by direction and date, belong to a continuation of the Himalayan system into south-western China. Various botanical and zoological collections were made, most of which are being examined at the Natural History Museum, London, and the Indian Museum, Calcutta.

### University and Educational Intelligence.

**BIRMINGHAM.**—The lectures on town-planning which form an interesting part of the activities of the department of civil engineering are on an unusually extended scale this session. These lectures owe their existence to the generosity of the late Mr. George Cadbury and the trustees of the Bournville Village Trust, and are intended not merely for the university students but also for municipal officers, professional men, and members of the general public. The first series, by Mr. William Haywood, is open to all without fee; it deals with the historical aspect of the subject, reviewing in turn ancient, mediæval, renaissance, and modern town plans, and concludes with a consideration of the possibilities of Birmingham. In the second series of lectures, three are to be given by Mr. H. H. Humphries, City Engineer of Birmingham, two by Dr. John Robertson, Medical Officer of Health, who will deal with the health aspects of town-planning and the importance of environment, and five by Mr. F. C. Minshull, Chief Assistant Solicitor to the City of Birmingham, on the legal aspects of the subject, the operation and administration of schemes. The third series, of twenty lectures by Mr. Haywood, is more particularly intended for students of civil engineering. Class work in surveying and in working out problems in site-planning is given each week during the winter and spring terms.

**CAMBRIDGE.**—It is proposed to create a readership in biochemistry, the income of which is to be provided partly by the income from a capital sum of 10,000*l.*, provided by Sir William Dunn's trustees.

The Henry Sidgwick Memorial Lecture at Newnham College will be delivered by Lord Rayleigh on December 2, the subject being "The Iridescent Colours of Natural Objects."

**EDINBURGH.**—Mr. C. G. Darwin, who was elected a Fellow of the Royal Society a few months ago, has been appointed as the first occupant of the newly instituted Tait chair of natural philosophy. Prof. Darwin is a son of the late Sir George Darwin, and since 1919 has been lecturer in mathematics at Christ's College, Cambridge, of which he is a Fellow. He is at present engaged in research at the Norman Bridge Physics Laboratory of the Californian Institute of Technology at Pasadena.

**LEEDS.**—The Treasury has sanctioned a grant to be made by the Ministry of Agriculture and Fisheries in aid of the new agricultural building. The Turner Tanning Machinery Company is to instal about 1100*l.* worth of new machinery in the Leather Industries Department.

Mr. A. H. Priestley has been appointed lecturer in bacteriology, and Mr. G. Priestley has been appointed assistant lecturer in cloth analysis.

**LONDON.**—The Senate has awarded to Mr. F. J. F. Barrington the William Julius Mickle Fellowship of 200*l.* in respect of the work which he has carried out during the past five years on the nervous mechanism of micturition.

The following doctorates have been conferred by the Senate—*D.Sc. in chemistry*: Mr. S. R. Illingworth, an internal student, of the Imperial College, Royal College of Science, for a thesis entitled "Researches on the Constitution of Coal"; *D.Sc. in economics*: Mr. R. M. Dawson, an internal student, of the London School of Economics, for a thesis entitled "The Principle of Official Independence";

*D.Sc. in physics*: Mr. E. V. Appleton, an external student, for a thesis entitled "Studies of the Triode Vacuum Tube"; *D.Sc. in veterinary science*: Mr. W. H. Andrews, an external student, for a thesis entitled "The so-called 'Staggers' or 'Pushing Disease' of Cattle in Natal," and other papers.

Applications are invited for the Graham scholarship in pathology in connexion with University College Hospital. The scholarship is of the annual value of 300*l.* and tenable for two years. The latest day for receiving applications (which should be sent to the Principal Officer of the University of London, South Kensington, S.W.7) is January 1. They must be accompanied by the names of not more than three references, one at least of which should be the name of some professor, lecturer, or teacher of the university or college in which the candidate has conducted his studies in pathology, and state the research upon which the applicant proposes to work.

**OXFORD.**—Sir William Dunn's trustees have offered to provide the sum of 100,000*l.* for the establishment of a School of Pathology, subject to certain conditions as to site, upkeep of chair and teaching staff, provision of a maintenance fund, etc. They have also offered the additional sum of 3000*l.* for the adaptation of the existing Department of Pathology as the future School of Pharmacology. At a meeting of Congregation on November 21 these offers were accepted.

The *Times* correspondent at Toronto states that a fire occurred in the upper floors of the University of Montreal on November 14, doing damage estimated at between 50,000*l.* and 60,000*l.*

It is stated in the *Chemiker Zeitung* that Dr. Fritz Straus, of Berlin, has been appointed professor of chemistry at the Breslau Technische Hochschule, and that Prof. Bodenstein has been invited to succeed Prof. Nernst in the Physical-Chemical Institute of the University of Berlin.

AMONG recent appointments are the following:—Mr. D. H. Peacock and Mr. F. J. Meggett to be professor of chemistry and professor of biological science respectively at Rangoon University, and Dr. R. A. Dart to be professor of anatomy in the University of Witwatersrand, Johannesburg.

The annual prize distribution to the successful students of the Northampton Polytechnic Institute, Clerkenwell, E.C.1, during the session 1921-1922 will be held at the Institute on Friday, December 1. Dr. S. Z. de Ferranti, past president of the Institution of Electrical Engineers, will distribute the prizes and certificates.

THE following will represent the universities in the recently-elected House of Commons, the names of new members being in italics:—**OXFORD.**—Lord Hugh Cecil (U.) and Sir Charles Oman (U.); **CAMBRIDGE.**—J. F. P. Rawlinson (U.) and J. R. M. Butler (Ind.); **LONDON.**—Sir Sidney Russell-Wells (U.); **COMBINED ENGLISH** (Manchester, Liverpool, Durham, Leeds, Sheffield, Birmingham, and Bristol).—Sir Martin Conway (U.) and H. A. L. Fisher (N.L.); **WALES.**—T. A. Lewis (N.L.); **SCOTLAND** (St. Andrews, Glasgow, Aberdeen, and Edinburgh).—Sir Henry Craik (U.), Sir George Berry (U.), and D. McCoig Cowan (N.L.); **QUEEN'S, Belfast.**—Sir William Whitla.

## Calendar of Industrial Pioneers.

**November 26, 1836.** John Loudon McAdam died.—The great improver of road-making, McAdam began his experiments in Ayrshire, continued them at Falmouth, where he was a contractor for the Navy, and in 1815 was made surveyor general of the Bristol roads, where he introduced the method of forming a bed of stones broken into angular pieces. His process was gradually adopted with great advantage to commerce in all parts of the world.

**November 27, 1811.** Andrew Meikle died.—A millwright of Houston Mill, Dunbar, Meikle was the inventor of the modern type of threshing-machine. His machine is said to have saved this country 2,000,000*l.* per annum. In 1784 he conceived the idea of drums armed with beaters, and the first machine was made in 1786. He continued to improve it, but reaped little pecuniary benefit from his invention. In 1809 a subscription for him realised 1500*l.*

**November 28, 1894.** Sir Henry Hussey Vivian, first Baron Swansea, died.—The son of a merchant connected with the copper-smelting industry, Vivian, after leaving the University of Cambridge, directed works at Swansea, patented improvements in metallurgy, and introduced the manufacture of spelter and the production of nickel and cobalt. Through his efforts Swansea became "the metallurgical centre of the world." Vivian was remarkable for his energy and ability; he took part in local and national affairs, and after sitting in Parliament for many years was, in 1893, raised to the peerage.

**November 29, 1766.** John Wyatt died.—With Lewis Paul, Wyatt is credited with the important invention of spinning by machinery. Originally a carpenter in his native village near Lichfield, he afterwards entered the employ of Matthew Boulton. The compound weighing-machine now in general use and the roller bearing were invented by him.

**November 30, 1866.** John Mercer died.—Born in Lancashire in 1791, Mercer began work at nine as a bobbin-winder and became a hand-loom weaver. He studied mathematics and chemistry, became known for his experiments in dyeing, and, from 1825 to 1848, was partner with Fort Brothers. He contributed to the chemistry of dyeing, propounded a rational theory of catalytic action, and in 1850, after a long series of experiments, discovered the process of "mercerising."

**November 30, 1906.** Sir Edward James Reed died.—One of the foremost naval architects of his time, Reed was trained as a shipwright in the Royal Dockyards. In 1860 he became the first secretary of the Institution of Naval Architects, and in 1863, at the age of thirty-three, was made chief constructor of the Navy, a post he held till 1870. He introduced the belt and battery system and designed H.M.S. *Devastation*, the first mastless sea-going turret ironclad. He afterwards designed many notable vessels for foreign navies, and as a public man was a strenuous advocate of scientific and technical education.

**December 1, 1850.** Aaron Manby died.—The builder of the first iron steam vessel to make a sea voyage, Manby founded the Horseley Iron Works at Tipton, Staffordshire, where, in 1821, he built the *Aaron Manby* of iron. This vessel was sent to London in pieces, put together in the Surrey Canal Dock, and in June 1822 crossed the Channel, taking a cargo of iron castings to Paris. Manby in 1819 established important engineering works at Charenton, supplied some of the earliest engines for the French Navy, and took a prominent part in the lighting of Paris by gas. E. C. S.

## Societies and Academies.

LONDON.

**Royal Society, November 16.**—Sir Charles Sherrington, president, in the chair.—A. S. Eddington: The propagation of gravitational waves. The potentials given in Einstein's theory represent not only the absolute gravitational disturbance of the field, but also the metric of the co-ordinate system which is to a great extent arbitrary; consequently the speed of propagation of the potentials is not necessarily the speed of the absolute disturbance. Einstein showed that, when the co-ordinate frame is chosen subject to a certain restriction, the potentials are propagated with the speed of light. Considering the propagation of plane waves on unrestricted co-ordinates, it is found that "transverse-transverse" waves continue to have the speed of light, whereas the other two types of waves have no fixed speed when Einstein's restriction is removed. The latter types do not correspond to any absolute disturbance of the field. Of the three conceivable types of transverse-transverse waves, one is inconsistent with the equations of entirely empty space,  $G_{\mu\nu}=0$ ; but this type nevertheless commonly occurs in Nature, namely, as a propagation of gravitational disturbance by light-waves. Divergent waves are also considered. Although the equations correspond to those of sound-propagation, no uniform spherical waves of gravitation can occur; they must always be complicated by doublet-sources for some of the components. The waves emanating from a spinning rod are worked out in detail, and it is found that (in agreement with Einstein) the rod must slowly lose energy by these waves; for a typical example the period of decay of the rotation is found to be of the order  $10^{25}$  years.

—J. H. Jeans: The theory of the scattering of  $\alpha$ - and  $\beta$ -rays. A theory of scattering is developed in which both the feeble encounters of the theory of multiple scattering and also the violent encounters of the theory of single scattering are taken into account. The presence of single scattering produces very nearly the same effect as can be produced by a suitable adjustment of the constants in the law of multiple scattering, and this renders the separate experimental study of single scattering very difficult.

—A. P. Chattock and L. F. Bates: On the Richardson gyro-magnetic effect. Richardson has shown that the angular momentum arising in a ferro-magnetic substance from unit change in its magnetic moment should have the value of  $1.13 \times 10^{-7}$  if gyrating electrons are responsible for its magnetism. Measurements of this quantity by the ballistic method for three specimens of iron and one of nickel are given. The results, divided by  $1.13 \times 10^{-7}$ , agree to within  $\frac{1}{2}$  per cent. with one another, and their mean is 0.6 per cent. greater than 0.500. Close proportionality also exists between the change of magnetic moment and the angular momentum resulting. The specimen used consisted of an upright wire suspended by a quartz fibre. By the introduction of a hinged joint between wire and fibre the adjustment of the magnetic axis of the wire to the vertical is much facilitated, and measurements were made on reversal of magnetism instead of on merely reducing it to zero. The more perfect symmetry resulting from this procedure may be the cause of the more consistent results obtained. The effect on the results of the eddy currents in the specimen was not more than a small fraction of 1 per cent. for the specimens used. At high dampings the ordinary damping correction gives values that are too large.—P. M. S. Blackett: On the analysis of  $\alpha$ -ray photographs. A large

number of photographs were taken of the ends of the tracks of  $\alpha$ -rays from polonium in both air and argon, using C. T. R. Wilson's expansion method. There are sudden bends made by the tracks due to collision with the atomic nuclei, and the actual form of these bends is obtained from measurements of the double images given by the special camera designed for the work by Shimizu. The frequency of occurrence of bends of given type are consistent with the existence of an inverse-square law of force between the  $\alpha$ -particles and the nuclei, when their distance apart lies between  $6 \times 10^{-12}$  and  $10^{-9}$  cm. for argon, and  $3 \times 10^{-12}$  and  $5 \times 10^{-10}$  cm. for air. The velocity of the  $\alpha$ -particles along the latter part of their tracks was also calculated from the frequency of the bends and found to be much lower than had been expected. Velocities so low as 10 cm. per second were obtained, and the relation connecting the velocity  $v$  and the range  $r$  was found to be roughly of the form  $v \propto r^{\frac{1}{2}}$ , instead of the form  $v \propto r^{\frac{1}{3}}$  found by Marsden and Taylor for the early part of tracks by other methods. No anomalous effects were discovered as regards frequency or type of collision.—**J. H. Jones**: The kinetic energy of electrons emitted from a hot tungsten filament. When allowance is made for experimental and secondary effects the distribution of energy agrees with that given by Maxwell's law. Of experimental errors the most serious are probably due to difficulties of measuring the small currents involved and the temperatures. These lead to uncertainties which in individual experiments may amount to so much as 10 per cent. The secondary effects probably arise from contamination of the heated surfaces. This tends to increase the apparent energy of electrons emitted and the increase may amount to so much as 20 per cent. The abnormal electron energies found by Ting, which were as much as 100 per cent. in excess of the Maxwell distribution value, do not appear under satisfactory experimental conditions.—**W. Wilson**: The quantum theory and electromagnetic phenomena. From the point of view of the quantum theory such systems as atoms possess stationary states which are subject to conditions expressed by the equations—

$$\int p_s dq^s = n_s h.$$

The paper is chiefly concerned with an extended form of these quantum restrictions in which the momenta,  $p_s$ , are replaced by more general momenta,  $\pi_s$ , involving the components of the vector potential of the external field to which the system is subjected.—**S. Marsh and A. E. Evans**: On measurements of electrode potential drop with direct current and alternating current electrolysis. Electrodes of polished platinum, platinum-black, gold and nickel were used, normal sulphuric acid serving as the electrolyte. With direct current, anodic and cathodic effects were examined; with alternating current, the frequencies ranged from 25 to 80. Experiments were also made with various current densities. With all the metals examined, the cathodic drop increases with time, the curves (especially with polished platinum) resembling saturation curves in radioactivity. The anodic drop decreases at first and then rises similarly to the cathodic curve. With alternating current the electrode drop decreases during an interval depending on the frequency and thereafter increases slightly. The cathodic curves probably represent the effect of occlusion, while the anode curves represent the opposing effects of oxidation and occlusion.

**Royal Microscopical Society**, October 18.—Prof. F. J. Cheshire, president, in the chair.—**R. Chambers**: New apparatus and methods for the dissection and

injection of living cells. With the new apparatus there is a complete absence of lost motion, and continuous and accurate control of the needle in every direction under an immersion lens. The needle is maintained in one plane while it is being moved. Adjusting devices facilitate placing the needle or micro-pipette in position. The instrument consists essentially of rigid bars which are screwed apart against springs, the movements of the needle tip being in small arcs of a circle with a radius of about  $2\frac{1}{2}$  in. There are three horizontal bars which are forced apart by two screws. When the screws are reversed, spring hinges at either end holding the bars together in pairs return them to their original position. A similar pair of vertical bars attached to the horizontal ones controls up and down movements of the needle. With this instrument the most delicate operations in micro-dissection, such as puncturing blood corpuscles or even cutting up chromosomes, can be performed. A new micro-injection apparatus is also described, as well as methods for making the needles and the moist-chamber.

**Zoological Society**, October 24.—Dr. A. Smith Woodward, vice-president, in the chair.—**J. P. Hill and R. H. Burne**: The foetal membranes and placentation of *Chironomys madagascariensis*.—**R. I. Pocock**: The external characters of the foetus of *Chironomys madagascariensis*.—**R. Kirkpatrick and J. Metzelaar**: On an instance of commensalism between a hermit-crab and a polyzoon.

**Society of Public Analysts**, November 1.—Mr. P. A. Ellis Richards, president, in the chair.—**C. Ainsworth Mitchell**: The colorimetric estimation of pyrogallol, gallotannin, and gallic acid. A ferrous tartrate reagent is used. The violet coloration produced is due to the pyrogallol group and, applied quantitatively, affords a measure of that group in different compounds. The reaction throws light on the constitution of gallotannin; and the results for tannin from China galls are more in accordance with the formula recently suggested by Nierenstein than with that previously accepted. To estimate gallotannin in the presence of gallic acid the substances are estimated together colorimetrically in terms of gallic acid or pyrogallol. The tannin is then precipitated with quinine hydrochloride and the gallic acid estimated in the filtrate. The difference between the two results, multiplied by a factor, gives the gallotannin. The method has been applied to the estimation of tannin and gallic acid in various natural and commercial products.—**H. E. Annett and M. N. Bose**: The estimation of narcotine and papaverine in opium. Small quantities of opium (1-2 grams) only were available from plants used in selection experiments on the poppy. In estimating narcotine and papaverine an old observation of Plugge's, that on addition of sodium acetate to an aqueous opium extract, narcotine, papaverine, and narceine are precipitated, was used. Given the right conditions, the first two are precipitated completely; the narceine carried down can be washed away with water, and in the washed precipitate after further purification narcotine can be estimated polarimetrically.—**H. E. Annett and R. R. Sanghi**: The estimation of codeine. Codeine is extracted by toluene from an aqueous alkaline extract of opium, converted into the hydrochloride, purified by re-extraction with toluene, and finally converted into hydrochloride and weighed as such. The process is an improvement of that previously described by Annett and Son.—**J. R. Nicholls**: The estimation of morphine. If a 50 per cent. alcoholic solution containing morphine liberated by means of ammonia is shaken with half its volume of chloroform,

about 85 per cent. of the total morphine is in the lower layer; 2 such extractions remove more than 99 per cent. The alcohol retards or prevents the crystallisation of the base from the upper layer, and ensures a rapid separation.—R. L. Morris: Further notes on the estimation of potassium: by perchlorate and cobaltinitrite methods. A modification for the direct estimation of potash in the presence of phosphates of calcium, magnesium, iron, etc., is described. Sulphates should be removed by precipitation with barium chloride. Drushel's modification of the cobaltinitrite-permanganate process gives trustworthy results. Half-saturated sodium chloride solution should be used for the final washing of the precipitate.

## EDINBURGH.

**Royal Society, November 6.**—Prof. F. O. Bower, president, in the chair.—J. H. Ashworth: On *Rhinosporidium seeberi*, with special reference to its sporulation and affinities. *Rhinosporidium seeberi* is parasitic in the connective tissue of the nasal septum of man, and causes proliferation resulting in the production of polypoid growths, a case of which has been under observation for four and a half years. The trophic stages of *Rhinosporidium* may be intracellular, but the great majority lie between the connective tissue cells. As growth proceeds, granules of protein and fat-globules appear in the cytoplasm and increase in number and in size. When the organism approaches 0.1 mm. in diameter the nucleus divides by mitosis. There are four chromosomes. Other nuclear divisions follow; the nuclei (with few exceptions) divide synchronously. About the time 128 nuclei are present the cell-wall, hitherto chitinous, becomes much thickened, except at one point, by deposition of cellulose on its inner surface. The nuclear divisions continue, and, after the twelfth, cleavage of the cytoplasm takes place and rounded cells are formed, which undergo two further divisions to form the spores (about 16,000). Usually a proportion of these are arrested in development, but the remainder enlarge, and in each, ten to sixteen refringent spherules of protein are formed in vacuoles in the cytoplasm. By this time the sporangium has reached a diameter of 0.25 to 0.3 mm.; its wall has become stretched, and at the point where cellulose was not deposited the wall eventually gives way, and the spores are launched into the tissues or escape through the ruptured surface of the polypus to the exterior. The spores which become lodged in favourable positions in the connective tissue grow, become sporangia, and produce a fresh crop of spores. Hitherto the nature of the spore has been misunderstood—the refringent spherules have been mistaken for spores. In view of the character of the nuclear divisions and the cellulose envelope of the sporangium, *Rhinosporidium* is regarded, not as a Sporozoon belonging to the Haplosporidia, but as belonging to the lower fungi (Phycomycetes) and in or near the Chytridinea.—J. Stephenson: On some Scottish Oligochaeta, with a note on encystment in a common freshwater oligochaete, *Lumbriculus variegatus* (Müll.). Descriptions of certain new and comparatively little known species of Microdrili are given; the limits of variability in certain organs and systems of the Enchytraeidae are discussed, particularly with reference to *Lumbricillus lineatus* (Müll.); and an account is given of the encystment of *Lumbriculus variegatus* (Müll.), a hitherto-unrecorded occurrence, on the margin of a Scottish loch in the dry summer of 1921.—Elsie I. MacGill: On the life-history of *Aphidius avenae* (Hal.), a braconid parasitic on the Nettle aphid (*Macrosiphum urticae*).

## PARIS.

**Academy of Sciences, October 30.**—M. Albin Haller in the chair.—M. d'Ocagne: The plane representation of space.—M. de Séguier: The divisors of certain linear Galoisian groups.—C. Camichel: The turbulent regime. An account of some experiments on the turbulent flow of water in tubes.—M. Maggini: The rôle of anomalous dispersion in the spectra of stars. Displacements of lines in the spectrum of a star may be due to pressure, radial velocity (the Doppler effect), anomalous dispersion, or a difference in the potential of gravitation. Displacements have usually been attributed to the Doppler effect, but it is shown that certain cases are more probably due to anomalous dispersion.—R. Goudey: An annual periodic variation of the rate of a pendulum.—M. Giacobini: Observations of the Baade comet, made at the Paris Observatory. Positions of the comet and comparison stars given for October 23, 24, and 25. The comet is small, about 10" in extent, and with a nucleus of about magnitude 12.—P. Chofardet: Observations of the Baade comet (1922c) made with the *coudé* equatorial of the Observatory of Besançon. Two positions are given for October 24.—A. Schaumasse: Observations of the Baade comet, made with the *coudé* equatorial of Nice Observatory. Positions of the comet are given for October 23, 26, 27. It was of 10.5 magnitude, with a nebulosity 1.5 in diameter, and presenting an elongation in the direction opposed to the sun.—M. Poivilliers: A new "stereo-autograph." A description of a modified stereoscope which permits of the preparation by mechanical means of a plan showing contour lines or vertical sections from two photographs. The scale may be varied at will and the apparatus is suitable for railway surveys.—Louis de Broglie and A. Dauvillier: Analogies of structure between the optical series and Röntgen series of lines. From the point of view of Bohr's theory, the analogy of structure between the optical series and Röntgen series is explained by the fact that the internal levels, K, L, M, etc., respectively are characterised by the same total number of quanta as the first virtual exterior levels at the last electronic layer. These last layers are responsible for the optical series.—A. Sellarier: The axial effects of the magnetic field, analogous with those of Righi-Leduc and Etingshausen.—Carl Benedicks: A study of the deformability of the photographic layer. It has been proved by astronomers that no sensible deformation of the photographic film takes place in ordinary star photography, but it is possible that the more intense light of the solar corona might produce a deformation and this would seriously affect such delicate measurements as the deviation of light passing through the field of gravity of the sun. The experiments described, designed to measure such a deformation, gave negative results, but the desirability of repeating the work with apparatus capable of giving higher precision is pointed out.—J. A. Muller: The degree of molecular polymerisation of substances at the critical state.—René Dubrisay: The action of boric acid on mannite in alkaline solution. To solutions containing equivalent proportions of boric acid and soda, increasing proportions of mannite were added and measurement made of the temperature of miscibility with phenol, the rotatory power, and the surface tension. No definite conclusions can be drawn from the experimental results. There always remains some soda uncombined, and there would appear to be at least two distinct compounds with mannite in the solutions.—M. Bonnier: The estimation of alkaline carbonates in presence of phenolphthalein. A statement of the

conditions under which solutions of carbon dioxide in caustic soda solutions can be titrated with accuracy.—L. J. Simon: The rôle of chromic oxide in oxidation with chromic and sulphuric acids.—Paul Bertrand: The coal flora of the Sarre coal measures.—R. Legendre: Diurnal variations of the hydrogen ion concentration of sea water near the coast. The hydrogen ion concentration of sea water taken near the coast varies during the day and passes through a maximum at about 3 P.M.—S. Metalnikow: Ten years' culture of infusoria without conjugation.—C. Delezenne and Mlle. Suzanne Ledebt: The transmission in series of the proteolytic power initially conferred on inactive pancreatic juice by enterokinase.—René Wurmser and Raymond Jacquot: The relation between the colloidal state and the physiological functions of protoplasm.—A. Pèzard and F. Caridroit: Subrenal-testicular interperitoneum in incompletely castrated cocks.—Edouard Chatton and André Lwoff: The evolution of the infusoria of lamellibranchs. The relations between the Hypocoma and Ancistrum. The genus Hypocomicides.—Et. Burnet: The relations between *B. Abortus* and *Micrococcus melitensis*.—J. Dumas, D. Combiesco, and J. Baltiano: The action of the tetanic and diphtheric toxins administered by the mouth. Experimental tetanus can be produced in the guinea-pig by adding the tetanus toxin to the food, but the rabbit is resistant. On the other hand, the rabbit is more sensitive than the guinea-pig to the action of the diphtheric toxin administered in the same way. These results are not in agreement with the results of other workers, and this is explained by the author by the fact that his preparations contained more of the toxins.

### Official Publications Received.

Zeitschrift für angewandte Geophysik. Unter ständiger Mitarbeit zahlreicher Fachgenossen. Herausgegeben von Dr. R. Ambronn. Band 1, Heft 1. Pp. 32. (Berlin: Gebrüder Borntraeger.)  
Annals of the Indian Meteorological Department. Vol. 22, Part 3: Mean Monthly Characters of Upper-Air Winds deduced from the Flights of Pilot Balloons at Thirteen Stations in India during the Period 1910 to 1919. By J. H. Field. Pp. 41-136. (Calcutta: Government Printing Office.) 2 rupees; 3s.  
Report of the Department of Industries, Madras, for the Year ended 31st March 1921. Pp. v+60-ii. (Madras: Government Press.)

Annals of the Transvaal Museum. Vol. 8, Part 4, containing Review of the Nomenclature of South African Birds, by A. Roberts; An Imperfect skeleton of *Proafrina Capensis*, Broom, in the Collection of the Transvaal Museum, by Dr. R. Broom. Pp. 185-276. Vol. 9, Part 1, containing Contributions to our Knowledge of the Dermaptera and Orthoptera of the Transvaal and Natal, by J. A. G. Rehn. Part 1: Dermaptera and Blattella. Pp. 99-4 plates. Vol. 9, Part 2, containing the Sphingidae of South Africa, by Dr. G. Arnold: New Forms of Lasiocampidae from the Transvaal Museum, by C. Aurivillius. Pp. 101-141. (Cambridge: Printed at the University Press.)

Transactions of the Rochdale Literary and Scientific Society. Vol. 14, 1919-1922. Pp. 128+xv+xl. (Rochdale.)  
Imperial Department of Agriculture for the West Indies. Report on the Agricultural Department, St. Lucia, 1921. Pp. iv+31. (Barbados.) 6d.

Nigeria. Annual Report on the Forest Administration of Nigeria for the Year 1921. Pp. 18. (Ibadan.)

The Botanical Society and Exchange Club of the British Isles. Vol. 6, Part 3, Report for 1921. By G. C. Druce. Pp. 261-546. (Arbroath: T. Bunce and Co.) 10s.

Shall the State throw away the Keys? An Exposition of what the Chemists mean to the Nation. Pp. 32. (London: Association of British Chemical Manufacturers, 199 Piccadilly.)

### Diary of Societies.

#### SATURDAY, NOVEMBER 25.

ASSOCIATION OF SCIENCE TEACHERS AND THE ASSOCIATION OF UNIVERSITY WOMEN TEACHERS (University College), at 11 and 2.30.—Joint Conference on the Teaching of Science in Schools and Colleges.

#### MONDAY, NOVEMBER 27.

ARISTOTELIAN SOCIETY (at University of London Club), at 8.—Prof. R. F. A. Hoernlé: Notes on the Treatment of "Existence" in recent Philosophical Literature.

ROYAL SOCIETY OF ARTS, at 8.—Prof. W. A. Bone: Brown Coal and Lignites (Cantor Lecture).

ROYAL SOCIETY OF MEDICINE (Odontology Section), at 8.—Dr. P. Watson-Williams: Infections of the Teeth and Gums in relation to the Nose, Throat, and Ear.

ROYAL GEOGRAPHICAL SOCIETY (at Eolian Hall), at 8.30.—C. Gillman: An Ascent of Kilimanjaro.

#### TUESDAY, NOVEMBER 28.

ROYAL HORTICULTURAL SOCIETY, at 3.—M. B. Crane: Self-Sterility and the Pollination of Fruit Trees.

ROYAL SOCIETY OF MEDICINE (Medicine and Ophthalmology sections)—Dr. B. Shaw, F. Moore, and others: Discussion on the Differentiation and Prognosis of Arterio-sclerotic and Renal Retinitis.

INSTITUTE OF CIVIL ENGINEERS, at 6.—E. O. Forster-Brown: Underground Waters in the Kent Coalfield, and their incidence in Mining Development. (Continued discussion.)

INSTITUTE OF MARINE ENGINEERS, INC., at 4.30.—Film Illustrative of the Conquest of Oil. Anglo-American Oil Co.

ROYAL PHOTOGRAPHIC SOCIETY OF GREAT BRITAIN, at 7.—J. E. Saunders: Off the Beaten Track at the Ipo.

SOCIOLOGICAL SOCIETY (at Royal Society), at 8.15.—H. Belloc: Factors of Historical Changes in Society.

#### WEDNESDAY, NOVEMBER 29.

NEWCOMEN SOCIETY (Annual General Meeting) (at Iron and Steel Institute), at 5.—at 5.30.—R. Jenkins: Notes on the Early History of Steel-making in England.

ROYAL SOCIETY OF ARTS, at 8.—Major W. S. Tucker: The Hot Wire Microphone and its Applications.

#### THURSDAY, NOVEMBER 30.

ROYAL SOCIETY, at 4.—Anniversary Meeting.

LINNEAN SOCIETY, at 5.—Dr. R. J. Tillyard: The Wing-venation of the Order Plectoptera, or May-flies.—D. M. S. Watson and E. L. Gill: The Structure of certain Falcate Dipod.

ROYAL SOCIETY OF MEDICINE, at 5.—Sir Almoth Wright: New Principle in Therapeutic Immunisation (Occasional Lecture).

CHILD-STUDY SOCIETY (at Royal Sanitary Institute), at 6.—Dr. A. P. Tregold: Some Problems relating to Mental Deficiency.

INSTITUTE OF ELECTRICAL ENGINEERS, at 6.—W. A. Gillott: Domestic Load Building: a Few suggestions upon Propaganda Work.

OPTICAL SOCIETY (at Imperial College of Science and Technology), at 6.—A. Whitwell: The design of Spectacle Lenses.—Dr. M. von Rohr: On the Available Means for Correcting Considerable Cases of Anisometropia.—A. Whitwell: The Best Form of Spectacle Lenses for the Correction of Small Amounts of Anisometropia.—

Dr. M. B. Dobson: Notes on the Non-operative Treatment of Squint.—9. Raphael: Standards of Accuracy for Ophthalmic Prescriptions.—W. A. Dixey: some Recent Developments in Spectacle Lenses.—J. H. Gardiner: Sir William Crookes' Antiglare glasses.—H. S. Ryland: Methods used in the Manufacture of Gold-filled Spectacles and Clips.

CAMERA CLUB, at 8.15.—C. Robbins: A Peep at Prehistoric Man.

ROYAL SOCIETY OF MEDICINE (Urology Section), at 8.30.—Dr. Langdon Brown and others: Discussion on the Factors in Uremia.

#### FRIDAY, December 1.

INSTITUTE OF MECHANICAL ENGINEERS, at 6.—Dr. T. E. Stanton: Some Recent Researches on Lubrication (Thomas Hawkesley Lecture).  
JUNIOR INSTITUTION OF ENGINEERS, at 7.30.—H. G. Brown: Machines used in Magnetic Separation.

### PUBLIC LECTURES.

#### SATURDAY, NOVEMBER 25.

HORNBY MUSEUM (Forest Hill), at 3.30.—F. Balfour-Browne: British Water-beetles.

#### MONDAY, NOVEMBER 27.

UNIVERSITY COLLEGE, at 5.30.—Miss E. Jeffries Davis: The Evolution of London. Succeeding Lectures on December 4 and 11.

CITY OF LONDON Y.M.C.A. (186 Aldersgate Street), at 6.—Col. Sir William H. Wilcock: Rheumatism and how to avoid it.

#### TUESDAY, NOVEMBER 28.

SCHOOL OF ORIENTAL STUDIES, at 5.—Sheikh M. H. Abd el Razek: The Study of Moslem Civilisation in Europe.

#### THURSDAY, NOVEMBER 30.

KING'S COLLEGE, at 5.30.—N. P. Jopson: The Distribution and Interrelations of the Slavonic Peoples and Languages.  
UNIVERSITY COLLEGE, at 6.30.—Dr. C. Pellizzi: Platone e l'Umanesimo (in Italian).

#### FRIDAY, DECEMBER 1.

ROYAL INSTITUTE OF PUBLIC HEALTH, at 5.—Prof. T. Madsen: Specific and Unspecific Antitoxin Production (Harben Lecture).

BEDFORD COLLEGE FOR WOMEN, at 5.30.—Miss E. Jeffries Davis: Roman London.

#### SATURDAY, DECEMBER 2.

HORNBY MUSEUM (Forest Hill), at 3.30.—Dr. E. Marion Delf: Vitamins and Health.

# NATURE

A WEEKLY ILLUSTRATED JOURNAL OF SCIENCE.

*"To the solid ground  
Of Nature trusts the mind which builds for aye."*—WORDSWORTH.

No. 2770, VOL. 110]

SATURDAY, DECEMBER 2, 1922

[PRICE ONE SHILLING

Registered as a Newspaper at the General Post Office.]

[All Rights Reserved.]

## NEWTON'S EPISCOPE

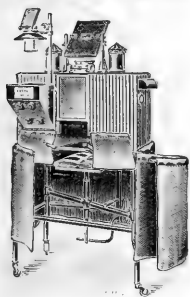

for the projection of  
**OPAQUE OBJECTS**

including  
MAPS. DRAWINGS.  
DIAGRAMS, PRINTED  
and TYPED MATTER,  
ILLUSTRATIONS,  
NATURAL OBJECTS,  
etc.

*Price list on application.*

Opticians to  
H.M. the King.

**NEWTON & CO.**

Estab. over  
200 years.

*Specialists in Optical Projection Apparatus for Visual Instruction.*  
**72 WIGMORE STREET, LONDON, W.1.**

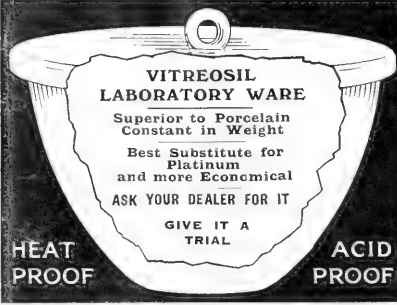

### VITREOSIL LABORATORY WARE

Superior to Porcelain  
Constant in Weight

Best Substitute for  
Platinum

and more Economical

ASK YOUR DEALER FOR IT

GIVE IT A  
TRIAL

HEAT  
PROOF

ACID  
PROOF

SOLE MANUFACTURERS

**THE THERMAL SYNDICATE, LTD.,**

VITREOSIL WORKS—WALLSEND-ON-TYNE.

LONDON DEPOT—28 VICTORIA ST., S.W.1.

AND AT PARIS AND NEW YORK.



**BAIRD & TATLOCK (LONDON) LTD.**  
SCIENTIFIC INSTRUMENT MANUFACTURERS  
and LABORATORY FURNISHERS.

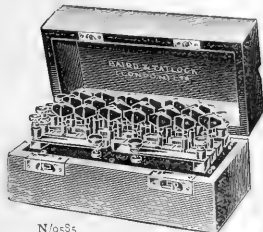

N/9585  
RESISTANCE BOX

Physical  
Apparatus  
for  
Schools  
and  
Colleges.

**14-15 CROSS STREET, HATTON GARDEN, LONDON, E.C.1.**



The Weather  
Watch is an ideal  
Christmas Gift.  
It forecasts the  
weather for the  
coming 12 hours.

In case

**£7 10 0**

**NEGRETTI & ZAMBRA**  
38, HOLBORN VIADUCT, E.C.1.  
LONDON.

## SWINEY LECTURES ON GEOLOGY, 1922-23.

Under the direction of the TRUSTEES of the BRITISH MUSEUM.

A course of twelve lectures on "FOSSILS AND WHAT THEY TEACH" will be delivered by Professor T. J. JEHU, M.D., F.R.S.E., in the Lecture Theatre of the Imperial College of Science (Royal College of Science, Old Buildings), Exhibition Road, South Kensington, on Tuesdays, Thursdays, and Fridays, at 5.30 P.M., beginning Tuesday, December 12, 1922, and ending Friday, January 12, 1923. The Lectures will be illustrated by Lantern Slides. ADMISSION FREE.

British Museum (Natural History).  
Cromwell Road, London, S.W.7.

## APPOINTMENTS BOARD

OF THE

### IMPERIAL COLLEGE OF SCIENCE AND TECHNOLOGY,

SOUTH KENSINGTON, S.W.7.

EMPLOYERS requiring men who have received a thorough training in Science and Technology, and who are Diplomates or Associates of the Imperial College, or of one of its three constituent Colleges, are asked to make use of the services of the Board. No fees.

The Imperial College includes The Royal College of Science, The Royal School of Mines, and The City and Guilds (Engineering) College. The Associates of the Colleges receive thorough training in Science and Technology, including Aeronautics, Applied Optics and Optical Engineering, Biology, Chemical Technology, Chemistry (all branches), Engineering (all branches, including Metallurgy, Mining, Mining Geology and Oil Technology), Geology, Mathematics and Mechanics, and Physics.

## THE INSTITUTE OF PHYSICS.

### APPOINTMENTS REGISTER AND PANEL OF CONSULTING PHYSICISTS.

The Appointments Register Committee is prepared to recommend to Public Departments, Universities and Colleges, Directors of Research, Manufacturers, and others desirous of employing or consulting fully-qualified Physicists, suitable persons possessing special knowledge of any branch of Physics.

By Order of the Board,

F. S. SPIERS, Secretary.

10 Essex Street,  
London, W.C.2.

## UNIVERSITY OF BRISTOL.

### DEPARTMENT OF AGRICULTURAL AND HORTI- CULTURAL RESEARCH, LONG ASHTON.

Applications are invited for the post of MYCOLOGIST. Particulars of the appointment may be obtained from the undersigned, to whom applications together with copies of three recent testimonials should be addressed not later than December 11, 1922.

JAMES RAFTER, M.A., Registrar.

## UNIVERSITY OF CAPE TOWN.

### HARRY BOLUS CHAIR OF BOTANY.

Applications are hereby invited for the HARRY BOLUS CHAIR OF BOTANY at the University of Cape Town, which will be vacant from January 1, 1923.

The holder of this chair will be required to take charge of the University Laboratories.

The salary is £500 per annum.

The Professor must become a member of the University Teachers' Super-annuation Fund.

Appointments are generally restricted to candidates under 35 years of age. In the case of a candidate who has been engaged in teaching or in research in South Africa this restriction need not apply.

Applications and copies of testimonials (seven copies) must reach the SECRETARY, office of the High Commissioner for the Union of South Africa, Trafalgar Square, London, from whom forms of application and further particulars may be obtained, not later than December 31, 1922.

The successful applicant will be required to assume duty not later than March 1, 1923.

## BIRKBECK COLLEGE.

(UNIVERSITY OF LONDON.)

Principal—GEORGE SENTER, D.Sc., Ph.D., F.I.C.

EVENING COURSES for the Degrees of the University of London in the Faculty of Science and for the Geography Diploma.

Facilities are also provided during both day and evening for Post-Graduate and Research Work.

Calendar, 1s.; by post, 1s. 5d. Prospectus free.

For full particulars, apply to the SECRETARY, Birkbeck College, Fetter Lane, E.C.4.

## THE

### COMMITTEE OF THE NORFOLK AGRICULTURAL STATION

require a DIRECTOR. Applicants must possess a modern scientific training in Agriculture, with University Degree or Diploma, a sound practical knowledge of mixed farming, organizing ability, and a facility for lecturing. Duties will include supervision of experimental farm, planning of cereal and other experiments, preparation of Reports for publication, dissemination of up-to-date knowledge amongst farmers in the County of Norfolk, and such other duties of an Agricultural Organizer as may fall within the scope of the Committee acting with the Ministry of Agriculture.

Engagement in the first instance for one year only. Salary £600, with travelling and incidental expenses paid. An office in Norwich will be provided.

All applications, accompanied by testimonials, to be made in writing not later than Saturday, December 9, to J. B. FORRESTER, Esq., 32 Prince of Wales Road, Norwich.

## UNIVERSITY OF BRISTOL.

THE UNIVERSITY invites applications for the CHAIR OF PHILOSOPHY, which will be vacant on July 31, 1923. Salary, £800 per annum.

Applications should be lodged, on or before February 3, 1923, with the REGISTRAR, from whom further particulars are obtainable.

## UNIVERSITY OF LONDON.

The Senate invite applications for the UNIVERSITY CHAIR OF ANATOMY, tenable at St. Bartholomew's Hospital Medical College. Salary £2000 a year. Applications (12 copies) must be received not later than first post on April 16, 1923, by the ACADEMIC REGISTRAR, University of London, South Kensington, S.W.7, from whom further particulars may be obtained.

## GOVERNMENT LABORATORY.

TEMPORARY ASSISTANT CHEMISTS wanted, age 20-25, required to have degree of B.Sc. with not less than Second Class Honours, or equivalent. Salary—Men, £160-£10-£220; Women—£140-£10-£180, plus usual Civil Service Bonus. At present £160 is equivalent to £264 11s., but this will be revised on March 1, 1923. Apply before December 10, with copies of testimonials, including any record of War service, GOVERNMENT CHEMIST, Clement's Inn Passage, London, W.C.2.

## PHYSICIST WANTED

for work in connection with ACOUSTICS. Qualifications.—Honours Degree in Physics and at least one year's experience in post-graduate work or research. Reply in writing (stating War experience, if any) to SECRETARY, Royal Engineer Board, War Office, Imperial House, Tothill Street, S.W.1.

## SPECIAL MICROSCOPICAL SLIDE :

Radium. Perpetually giving off numerous flashes of intense light.  
Post free, 2s. 3d. DARLINGTON, 31 Freer Road, Birchfield, Birmingham.





SATURDAY, DECEMBER 2, 1922.

## CONTENTS.

	PAGE
Smallpox and Vaccination . . . . .	725
Religio Chirurgi . . . . .	726
Chemical Technology . . . . .	726
Forward Progression . . . . .	728
The Nature of Science . . . . .	728
Aspects of Military Medicine. By W. B. . . . .	729
Our Bookshelf . . . . .	730
Letters to the Editor :—	
The Isotopes of Antimony.—Dr. F. W. Aston, F.R.S. . . . .	732
Experiments on the Theory of Soil-acidity.—Prof. J. N. Mukherjee . . . . .	732
New Spectra of Water Vapour, Air, and Hydrogen in the extreme Ultra-violet.—J. Hopfield . . . . .	732
Molecular Viscosity.—Frank M. Lidstone . . . . .	733
New Weights and Measures for India.—Howard Richards; C. A. Silberrad . . . . .	734
Harpoons under Peat in Holderness, Yorks.—T. Sheppard . . . . .	735
The Relationship between the common Hermit-crab ( <i>Eupagurus bernhardus</i> ) and the Anemone ( <i>Sagartia parviticola</i> ). (Illustrated).—Dr. J. H. Orton . . . . .	735
First Lessons in Practical Biology.—E. W. Shann; The Reviewer . . . . .	736
The Mechanism of the Cochlea.—Dr. G. Wilkinson . . . . .	737
An Offer of <i>Nature</i> Volumes.—M. Gheury de Bray . . . . .	738
Human Blood Relationships . . . . .	738
The History of the Photographic Lens . . . . .	739
Obituary :—	
Prof. Heinrich Rubens. By R. W. L. and Sir Joseph Larmor, F.R.S. . . . .	740
Lieut.-Col. G. L. Tupman. By Dr. A. C. D. Crommelin . . . . .	742
H. J. Powell . . . . .	742
Current Topics and Events . . . . .	743
Our Astronomical Column . . . . .	747
Research Items . . . . .	748
The Society of German Men of Science and Physicians. By Prof. B. Rassow . . . . .	750
The Present Position of Darwinism . . . . .	751
Effects of Local Conditions on Radio Direction-finding . . . . .	753
New X-ray Department at Manchester University and Educational Intelligence . . . . .	753
Calendar of Industrial Pioneers . . . . .	754
Societies and Academies . . . . .	756
Official Publications Received . . . . .	760
Diary of Societies . . . . .	760

Editorial and Publishing Offices :

MACMILLAN &amp; CO., LTD.,

ST. MARTIN'S STREET, LONDON, W.C.2.

Advertisements and business letters should be addressed to the Publishers.

Editorial communications to the Editor.

Telegraphic Address: PHUSIS, LONDON.

Telephone Number: GERRARD 8830.

NO. 2770, VOL. 110]

## Smallpox and Vaccination.

THE present limited outbreak of smallpox in London gives point to the leaflet on smallpox and vaccination issued by the Research Defence Society. The widespread distribution of this circular would help in dissipating much misapprehension on the subject. Those requiring a more detailed exposition will find it in a recent report of nineteen pages issued by the Ministry of Health at the price of 3d.

The leaflet of the Research Defence Society points out that some fifteen million persons in England and Wales at the present time are unprotected against smallpox by vaccination. Figures are quoted illustrating the well-known facts that smallpox attacks chiefly the unvaccinated, that the fatality among unvaccinated is much higher than among vaccinated patients, and that practically no vaccinated child under ten years old suffers from the disease.

The supply of glycerinated calf lymph renders it impossible for either tuberculosis or syphilis to be conveyed by vaccination. This danger was always remote. It is now extinguished. The occurrence of complications after vaccination is avoidable if proper care and cleanliness are maintained. Yet a large proportion of the total population are unprotected by vaccination, and are dependent for their freedom from smallpox, on the prompt recognition and notification of every case of smallpox, on the intelligence and completeness of the work of the medical officer of health, and on the satisfactory working of every part of the machinery of sanitary administration which, almost times without number, has restrained outbreaks of smallpox within a small circle. This machinery comprises hospital isolation of patients, disinfection, a complete list and daily surveillance of contacts with the patient, and the surrounding of the patient with a complete ring of persons protected by vaccination, including sanitary inspectors, disinfectors, ambulance drivers, doctors, nurses, wardmaids, and so on.

It is this ring of protected persons and the prompt vaccination or revaccination of all who have been exposed to infection which enables us to point to a record of smallpox prevention of which the country can be proud—a record in remarkable contrast to the national record as regards whooping-cough and measles. Every person vaccinated and revaccinated diminishes the strain on public health administration; and if this means of protection were to be systematically and universally adopted, smallpox hospitals would no longer be required.

## Religio Chirurgi.

WE have received an address to theological students by that famous and well-beloved old surgeon, Dr. W. W. Keen of Philadelphia, the master and the representative of American surgery, whose work has long been honoured over here. He gives to his address the title "Science and the Scriptures"; but, of course, he is concerned with that hardship of thought which all of us confess. In America, he says, there is a mischievous "recrudescence of the warfare over Evolution": and he sets himself, by sixty-two years' study and teaching of anatomy and surgery, to confute such people as look for their science to the Book of Genesis, and say that man was "a separate direct creation." He finds it easy enough to establish a more reasonable view, and we over here can only wonder that it should now be necessary to do so. The distinctive mark of this address is, however, Dr. Keen's determined will to be as strong in the Christian faith as in his reasons touching evolution.

"I believe that man, himself, will only attain his final development in the future life beyond the grave. In that wondrous life I believe as fully as I do in my own present existence. . . . Bodywise, man is an animal, but, thanks be to God, his destiny is not the same as that of the beasts that perish. To develop great men, such as Shakespeare, Milton, Washington, Lincoln, and then by death to quench them in utter oblivion would be unworthy of Omnipotence. To my mind it is simply an impossible conclusion. Man's soul must be immortal."

Therefore, Dr. Keen invents a phrase that the moral and spiritual life of man has been "engrafted upon" his natural life. The phrase is, however, unsatisfying. Man's likeness bodywise to animals is acknowledged, but Dr. Keen evades the animal's likeness conductwise to man. What is the use of Shakespeare and Milton to us who do not admit any great difference or gap between animals at their highest and man at his lowest?

Doubtless, in this quandary, it may advantage us to remember that no science has anything to say about personality. There is a lot of slipshod talk about organisms; but not a word about the animal itself, the inscrutable person which is the cat or the dog, the very self which is "engrafted upon" the animal organism. Until we understand—which possibly we never shall—the mystery and secret of the creation of animals, we shall remain in a quandary that is too deep for scientific analysis. The only way of escape seems to be that which Dr. Keen has taken. It reconciles no difficulties. It holds things apart, not brings them together. Still, he is not the only man, full of age and experience, who has taken this way; and we may get, from his outspoken declaration of faith, a touch of that delight which Socrates always found in talking to old men.

## Chemical Technology.

- (1) *The General Principles of Chemical Engineering Design*. By Hugh Griffiths. (Chemical Engineering Library.) Pp. 63. (London: Benn Brothers, Ltd., 1922.) 3s. net.
- (2) *Materials of Chemical Plant Construction—Non-Metals*. By Hugh Griffiths. (Chemical Engineering Library.) Pp. 64. (London: Benn Brothers, Ltd., 1922.) 3s. net.
- (3) *The Weighing and Measuring of Chemical Substances*. By H. L. Malan and A. I. Robinson. (Chemical Engineering Library.) Pp. 63. (London: Benn Brothers, Ltd., 1922.) 3s. net.
- (4) *The Flow of Liquids in Pipes*. By Norman Swindin. (Chemical Engineering Library.) Pp. 64. (London: Benn Brothers, Ltd., 1922.) 3s. net.
- (5) *Pumping in the Chemical Works*. By Norman Swindin. (Chemical Engineering Library.) Pp. 80. (London: Benn Brothers, Ltd., 1922.) 3s. net.
- (6) *Recent Progress in Rubber Chemistry and Technology*. By Dr. P. Schidrowitz. Pp. 64. (London: Benn Brothers, Ltd., 1922.) 3s. net.

IT was, we believe, Pascal who observed that knowledge tends to concentrate itself in little books. The half-dozen monographs, published by Messrs. Benn Brothers, of which the titles are given above, are at least an exemplification of the truth of this aphorism. They form members of a series intended primarily for the use of the chemical engineer. The information they afford is given in what may be called "tabloid" form. They are small octavo booklets of some sixty or seventy pages, and are suitably illustrated. The actual amount of letterpress is, therefore, very small. Still, small as they are, they are packed with useful data, and as they are compiled by authorities and are brought up-to-date, they will no doubt be found useful by the class of technologists for whom they are more particularly designed.

(1) "The General Principles of Chemical Engineering Design," by Mr. Hugh Griffiths, treats of the essentials of a successful chemical plant: its physical, chemical, and mechanical factors; its practical and economic factors; and the settlement of the final design in the light of experience of the working of these factors—a matter frequently of no small difficulty in view of the complexity of the problem. The book may be regarded as introductory to the series. It deals simply with first principles and generalities, illustrated here and there by facts based upon practical experience. It is well written and suggestive, but contains little but what a chemical manufacturer is already well aware of, from, it may be, a more or less painful experience. The little book would serve admirably as the intro-

ductory discourse to a course of instruction on the technique of chemical manufacture.

(2) In his little work on materials of construction Mr. Griffiths deals with facts rather than with principles. In his introduction he speaks somewhat contemptuously of the designing engineer who has but little knowledge of chemistry, and of the research chemist who is ignorant of even the most elementary principles of mechanics, both of whom know little or nothing of the behaviour of materials of construction towards the action of chemical substances under the special conditions of the manufacture, but who are yet called upon, one to design and the other to work the plant.

There is no doubt that in too many cases the strictures are well merited. So long as chemical manufacture is confined, as in the case of so-called "heavy chemicals," to comparatively few substances and those of a restricted class, the disastrous results, material and financial, of such ignorance are not likely to be very serious. But as the range of his work extends, the chemist is called upon to face an increasing complexity of conditions in manufacture, and he cannot be too well informed concerning the application of constructional materials to chemical plant: he must know, not only the usual influences of atmospheric action, weathering, rusting, etc., but also the effects of physical conditions and the specific action of substances in varying circumstances of temperature, pressure, catalytic influences, etc.

In the space of some six or eight short chapters the author deals with the properties of bricks and tiles, refractories; stone, natural and artificial; ceramic materials and glass; rubber, ebonite, leather etc., wood; and a variety of non-metallic materials, such as mortar, cement, lutes and jointings, paints and enamels. In the very limited space allowed to the author, the treatment is necessarily highly condensed, but it gives the essential facts accurately and in sufficient detail.

(3) The little book on "The Weighing and Measuring of Chemical Substances," by Messrs. Malan and Robinson, is concerned solely with these operations as they may, or should be, carried out in chemical works. It deals with the general mechanical principles and theoretical considerations applicable to the various types of instruments employed. These, of course, differ according to the physical nature of the substance to be weighed or measured, *i.e.* whether solid, liquid, or gaseous. All the commoner forms of apparatus are referred to, as well as those of modern type, some of which are of rather elaborate construction and need intelligent use. The booklet may be commended as a useful account of methods to be employed in checking

the various stages of the production of a manufactured article with the view of economy and the prevention of waste.

(4, 5) The two books by Mr. Norman Swindin on the flow of liquid chemicals in pipes and chemical works pumping are concerned with associated subjects of great importance to the chemical engineer. In the first-named the general principles involved in the consideration of viscous flow—kinematic and absolute viscosity, the relation between mean velocity and velocity at axis of pipes, the practical application of the kinematic viscosity equation, the flow of liquids in channels, and pipe-line losses—are set out in such detail as the very limited space at the author's disposal permits.

Justice is done to the classical work of Osborne Reynolds and to the more recent investigations at the National Physical Laboratory by Dr. Stanton, and of Mr. E. Parry of the English Electric Company. In the discussion of the various formulæ for expressing the relation between viscosity and temperature, Rodger, the collaborator of Thorpe in their investigation of the connexion between viscosity and chemical constitution, is inadvertently spelt Rogers. The book concludes with a number of useful tables showing the viscosities at different temperatures and the densities of various liquids of importance in the chemical arts.

The booklet on pumping contains a description of the construction and mode of working of pumps employed in connexion with corrosive liquids—a problem of a very different order of difficulty compared with that with which the hydraulic engineer has usually to contend. The various types of pumps applicable to the conditions in chemical works are succinctly described with the aid of suitable figures and diagrams. Both books are useful compilations, and will be of service to the works manager and chemical engineer.

(6) Dr. Schidrowitz's little book on "Recent Progress in Rubber Chemistry and Technology" is a work of a very different order, and is in no wise connected with the Chemical Engineering Library. It deals more particularly with the extraordinary development of our knowledge concerning the nature of rubber, especially of plantation rubber, the conditions of its economical production, the mechanics of vulcanisation, the properties of vulcanised rubber, and the technique of rubber manufacturing processes—a development largely due to the creation of the tyre industry. Dr. Schidrowitz is an acknowledged authority on the subject of his book, and it is certain, therefore, to command the attention of all who are interested in rubber, whether as producers or as manufacturers. It is significant how little is heard to-day of synthetic

rubber; as a possible competitor of the natural variety its future appears hopeless. More plantation rubber is being produced than the world at present requires, or is likely to require for some time to come. At the same time, the investigations which have led to the synthesis of rubber, or of rubber-like substances, have great theoretical value, and have shed much light on the true nature and chemical constitution of this most remarkable substance.

### Forward Progression.

*Gaseous Exchange and Physiological Requirements for Level and Grade Walking.* By Henry Monmouth Smith. (Publication No. 309.) Pp. viii + 310. (Washington: Carnegie Institution, 1922.) 6 dollars.

FORWARD progression, perhaps the form of muscular activity most commonly engaged in by the average human being, is, both in its anatomical and physiological aspects, one of extraordinary complexity. The work of Marey, Carlet, Braune and Fischer has thrown much light on the actual movement of the body and legs during the forward movement, and the researches of Zuntz and Schumburg, Durig, Douglas, Benedict and Murschhauser, and others have helped towards the elucidation of the metabolism and energy expenditure of the movement. A number of problems which have emerged from the previous investigations still remain unsolved; some of these questions are discussed, and in part elucidated, in this new volume from the Carnegie Institution's Nutrition Laboratory at Boston.

This book forms the natural sequel to the work of Benedict and Murschhauser. These workers dealt with the changes in the metabolism, the cost and the efficiency of the human body during horizontal walking. Monmouth Smith's work, although ostensibly it is meant to deal principally with "grade" walking, contains much new data on horizontal walking, more especially as regards the influence of the movement and change of position on the blood pressure, pulse and temperature. The effect of horizontal walking on the blood pressure is not great; as regards the pulse rate, one of the most striking features is the great variation found in the same subject under apparently identical conditions. In connexion with the rectal temperature several interesting facts emerge: (a) there is a definite lag in the rise of temperature which occurs in changing from standing to walking; (b) except at the higher rates the effect of the rate of walking is small; and (c) the maximum increase at any speed less than 100 metres per minute does not exceed 0.5° C. (without taking into consideration the duration of the exercise).

Many new observations have also been made on the "step-lift." A slightly lower value for the cost of this operation than that of previous workers was found. A slightly lower value than that commonly accepted was also found for the energy cost per horizontal kilogrammetre.

In the grade-walking experiments a preliminary series of experiments were made on the influence of the mouthpiece on the breathing of the subject. These tests are of considerable technical interest. The general result is that unless the preliminary period of breathing with the mouthpiece in position be of sufficient duration, the accuracy of the determination of the respiratory quotient is endangered.

A large number of observations were also made on the influence of grade walking, in addition to the determination of the energy cost, on the blood pressure, pulse, pulmonary ventilation, and temperature. Those on the temperature are particularly interesting. It was found, for example, that the temperature increase was not always the same for the same amount of work, although, as might be expected, a higher temperature and a greater increase over normal were usually observed when the work and the metabolism were greatest. The maximum total increase, when the work done was heavy, was between 1.5° C. and 2° C. A number of very interesting experiments on the rate of the fall of the rectal temperature after the cessation of work are recorded. In one experiment at least it was very rapid, 1.14° C. in twelve minutes, or 0.09° C. per minute. On the other hand, if observations were continued, the rectal temperature was found to approximate normal pre-work temperature only about two hours after the cessation of work.

### The Nature of Science.

*What is Science?* By Dr. Norman Campbell. Pp. ix + 186. (London: Methuen and Co., Ltd., 1921.) 5s. net.

WHAT is Science?" is a question that may be answered in as many ways as "What is Truth?" and much depends on the questioner. In this case the original questioner was apparently an audience drawn from the Workers' Educational Association. Fifty or more years ago the worker was all agog for science; now, it appears, he either shoulders it aside as too academic for practical use, or rejects it as the "stone" of vocational education proffered instead of the "bread" of culture. The worker, in this limited sense, is not alone in misapprehending what is meant by "science," for the public at large, as recent years have given abundant proof, often blames it for sins

of both commission and omission, due really to human nature. It is well then that we should be provided in this handy form with a clearly-written and common-sense account of what scientific men mean by "science."

So much for the form, of the answer. As for its content, Dr. Campbell will find one or other of his statements disagreed with by each philosopher in turn. But he refrains, wisely, from straying far along the perilous paths of metaphysics, and, while expressing his own opinion, admits frankly that there are others. If the question is to be answered by way of definition, Dr. Campbell's may be accepted as giving at any rate one point of view: "Science is the study of those judgments concerning which universal agreement can be obtained." In rebutting the objection that there cannot be universal agreement, Dr. Campbell selects as the most perfect example the order in which events occur. But have not some of the relativists suggested that agreement on this may not necessarily be universal?

Probably a definition is not the best way of answering the question. Dr. Campbell's definition may be true, but it does not cover the whole ground. It has one advantage, in that it omits reference to "the external world of nature," and that advantage is not merely metaphysical but practical, since without further discussion it permits one to include the study of the human mind and its products. It has been the attempt to define science by reference to its subject matter that has led to much of the misunderstanding. Science is, it seems to us, rather a way of looking at things or a method of study, and if it excludes any subject it is only because the method proves inapplicable. Undoubtedly a necessary condition is agreement upon the judgments. Take literature for example. Purely æsthetic criticism will never give that "Quod semper, quod ubique, quod ab omnibus" which science demands; and science therefore must decline to appraise the poetic merits of "Lear," "Hamlet," and "Macbeth." But the number of lines with weak endings in those plays can be ascertained definitely, and can therefore be subjected to scientific inquiry.

How science works is the subject of three chapters, which consider the nature, the discovery, and the explanation of the laws of science. We used to be taught that "a Natural Law is a regular sequence of Cause and Effect." Dr. Campbell discards the causal relation and replaces it by "invariable association." It is this invariability that lies at the base of the definition of science recently given by the Master of Balliol: "a body of generalisations from facts which enables us to predict fresh facts." But further inquiry shows that the associations, in their original sense, are not invariable. Exceptions arise and have to be met by new laws, either of the same kind or of a new type.

The discovery of a new type of law is the privilege of genius. So far one may go with Dr. Campbell, but when he implies that the genius imposes the law in accordance with his "intellectual desires" and that "the universe obeys the dictates of [his] mind," it is not so easy to follow him. Does he mean that all our systems are purely subjective? To some extent the answer to this question is given in the section headed "Are theories real?" The reality of a theory depends on its power of predicting true laws, and thus it gains universal acceptance. "A molecule is as real, and real in the same way, as the gases the laws of which it explains. It is an idea essential to the intelligibility of the world not to one mind, but to all; it is an idea which nature as well as mankind accepts. That, I maintain, is the test and the very meaning of reality."

The position is intelligible, but our difficulties recur when we come to the interesting remarks on symbols and the æsthetic sense of the mathematician—"one more illustration of the power of pure thought, aiming only at the satisfaction of intellectual desires, to control the external world." Would it not be truer to say that the external world, by countless direct and indirect means, acting since life began, has so influenced the unconscious as well as the conscious perceptions of man, that the mind necessarily regards as harmonious those relations which conform to the seen or unseen reality of the universe? The scientific genius is he who has a deeper intuition of that harmony than his fellows, or, perhaps more accurately, he who can the most easily raise to the plane of consciousness the subconscious promptings of external nature.

### Aspects of Military Medicine.

*History of the Great War, based on Official Documents. Medical Services: Diseases of the War. Vol. i.* Edited by Major-General Sir W. G. MacPherson, Major-General Sir W. P. Herringham, Col. T. R. Elliott, and Lt.-Col. A. Balfour. Pp. viii + 550. (London: H.M.S.O., 1922.) 21s. net.

UP to the beginning of the nineteenth century the medical history of wars was very incomplete, and is to be found in memoirs or commentaries written by individual military surgeons. To this category belong the works of Percy, M'Grigor, and particularly Barron Larrey, the great military surgeon of the Napoleonic period. A great change, however, took place with the publication by the Americans of the splendid and exhaustive "Medical and Surgical History of the War of Rebellion (1861-1865)," which has remained a model for all later works on military medicine. After the greatest of all wars it was to be

expected that the medical histories which were bound to make their appearance would be voluminous and detailed, and that this country would not be behind others in this respect. The volume before us does not lead one to anticipate a standard work of permanent value in medical literature. From the brief preface, occupying a page and a half, it is not clear what the object of the work is. It is stated that the contributors had at their disposal the material contained in official documents, while later on it is said that "there has been little opportunity for further analysis and study of accumulated records of medical cases," and an apology is made that the contributors have been handicapped by the fact that papers published during the war were comparatively few. To any one conversant with the volume of medical literature which poured out in every country, this must seem an extraordinary statement. The "Index Medicus War Supplement," dealing with 1914-17, occupies alone 260 pages of titles, which at a conservative estimate represents at least 10,000 papers which were published on some aspect of military medicine during these three years.

Whatever was the intention of the editors, the book before us consists, in fact, of a series of short essays dealing with general statements rather than with actual data acquired during the war with respect to the several diseases of which they treat. Thus typhus fever and cholera are disposed of in sixteen and thirteen pages respectively, while the article on "General Aspects of Disease during the War" occupies less than ten complete pages. The other articles deal with such conditions as the enteric group of fevers, dysentery, cerebro-spinal meningitis, malaria, trench fever, jaundice, scurvy, beri-beri, pellagra, nephritis, and cardio-vascular diseases.

There are twenty-one contributors, and of these but four were regular officers in the army. It cannot serve a useful purpose to make an analysis of each of the individual articles. Many are sketchy, some are trivial, but those of Dr. Wenyon on malaria, of Sir W. Willcox on scurvy and beri-beri, of Sir J. Rose Bradford on nephritis, of Dr. Hume on cardio-vascular diseases, and of Col. Lelean on pellagra, are worthy of study. We are informed in the article on cholera that "all recent evidence shows that the cause of cholera is infection with the cholera bacillus." The word "recent" must here be taken as implying a period of nearly forty years.

The bibliographies in general are short, and some bear the impress of the professional copyist from the "Index Medicus" rather than represent the works consulted by the authors. In some cases the references given are to abstracts and epitomes and not to

the original works, although the latter were easily accessible. References such as "Nicolot, Bour, Monier-Vinard and Buguet, *Le Paludisme*," without date or *locus* of publication, are not helpful to the reader. The coloured illustrations, six in number, are successful, but the index bears evidence of having been compiled by some one unfamiliar with this class of work. In future volumes it is to be hoped that some of the defects of this one will be rectified. Compared with the greatness of the subject, the appearance of the volume is not attractive.

W. B.

### Our Bookshelf.

*Engineering Inspection.* By Prof. E. A. Allcut and C. J. King. Pp. xv + 187. (London: G. Routledge and Sons, Ltd., 1922.) 15s. net.

THE authors of the work under notice commence with a summary of the objects of inspection, and follow this by descriptions of inspection methods ranging from the inspection of raw materials to the carrying out of running tests on the manufactured product. These descriptions should make the book valuable to inspection staffs, who will find therein much of the information required in ordinary inspection work. In many cases references are given to original papers dealing with special methods of inspection, while the general information given in the text is amplified by a collection of useful tables in the appendix. In some respects the last chapter is the most important in the book, since it deals with the kind of temperament, as well as the qualifications, required in inspectors and viewers. Throughout the book the authors emphasise the point that the aim of an inspector should be to "scrap" as little work as possible, to detect faults in materials and workmanship at the earliest possible stage of manufacture, and to pass all sound work with the minimum delay. The type of organisation sketched out will be of interest to all engineers, and may indicate lines on which existing inspection systems can be improved; the general tone of the book should serve to remove much of the distrust with which inspection is still viewed by many. The authors are to be complimented on having presented so comprehensive a survey of an important subject in such a readable and well-balanced form.

*The Emotions.* By Carl G. Lange and William James. (Psychology Classics, vol. 1.) Pp. 135. (Baltimore, Md.: Williams and Wilkins Co., 1922.) 4 dollars.

WILLIAM JAMES and Carl Lange, investigating the problem of the emotions, independently and within a year, arrived at a very similar point of view with regard to the relation between the emotion as experienced by the subject and its bodily expression. The theory, generally known as the James-Lange theory, inverts the usual common-sense sequence which would say that we cry because we are sorry, and asserts that, on the contrary, we are sorry because we cry. Practically every student of psychology since the publication of the original articles has had to consider this conten-

tion; it is fairly easy to criticise, extremely easy to ridicule, and yet still remains provocative.

Very much more knowledge of the physiological processes concerned in emotion is available now, and although few thinkers could be found to accept the theory in its more extreme form, nevertheless it still has vitality.

The whimsical humour characteristic of James's writing arrested most readers' attention, and there seems little doubt that, although it in its turn had been stimulated by the work of Darwin, the publication of this theory gave considerable impetus to the study of the emotions and their relation to organic processes.

The present book, a reprint of James's and Lange's work, will be a valuable addition to the psychologist's library, presenting as it does, in convenient form, papers hitherto not easily obtainable.

*A Manual of Clinical Laboratory Methods.* By Prof. Clyde L. Cummer. Pp. 484. (London: H. Kimp-ton, 1922.) 28s. net.

DR. CUMMER has produced this manual for students and practitioners with the object of presenting clinical laboratory methods in concise and accessible form. The book is divided into seven chapters dealing with different materials—the examination of blood, of urine, of gastric contents, etc. In each, the methods of carrying out an investigation are first described, and the significance of the findings is then discussed.

The subject-matter of each section is well arranged, and there are numerous excellent engravings and plates; but there is much detail which could with advantage have been omitted. The method of using the inaccurate Tallquist haemoglobinometer does not merit description in a text-book which aims at being concise; nearly half the book is devoted to the examination of the blood, and the chapter on urine is comparatively brief; the estimation of basal metabolism is not mentioned at all. The best section is that on cerebrospinal fluid, which contains good descriptions of modern investigations, including the Lange colloidal gold reaction.

*The Teaching of General Science.* By Prof. W. L. Eikenberry. (University of Chicago Nature-Study Series.) Pp. xiii+169. (Chicago, Ill.: University of Chicago Press, 1922.) 2 dollars.

THE rapid spread of the teaching of general science follows on the recognition of the educative value of the subject. Much of this is lost, so far as children are concerned, if the content is restricted to what may be useful for some of them in future training as specialists. "The preparatory values are incidental. The adjustment between general science and special science must be made by the latter building upon what foundation the former lays, rather than by any attempt to prescribe that certain materials shall be used for preparatory reasons." This is the main idea underlying Prof. Eikenberry's book, in which he describes the history and practice of the teaching in America. He has gone to the root of the matter, dealing fully with the principles on which practice should rest; and the result is a book which no one who has the interests of science teaching at heart can afford to ignore.

*The Elements of Astronomy.* By Prof. D. N. Mallik. Pp. viii+233. (Cambridge: At the University Press, 1921.) 14s. net.

THE problems of the diurnal rotation, meridian observations, the motion of the moon and planets, precession, nutation, refraction, etc., are dealt with in quite an elementary manner in the work under notice. The chief new feature is an interesting account of ancient Indian astronomy. The book is, unfortunately, greatly in need of revision, misprints, misspellings, and other errata being numerous. Some of them are likely to cause serious misconceptions; thus, the moon's distance is given as 23,800 miles, both on pp. 102 and 117. On p. 146 the distance of Europa from Jupiter is given as 9400 miles; on p. 138 the periodic time of a planet is stated to vary as  $r^3$ . It is difficult to suppose that the proofs were read with any care. A. C. D. C.

*The Iron and Steel Institute. Carnegie Scholarship Memoirs.* Vol. II: *The Corrosion of Iron.* By Dr. J. Newton Friend. Edited by George C. Lloyd. Pp. vi+161. (London: The Institute; E. and F. N. Spon, Ltd.; New York: Spon and Chamberlain, 1922.) 16s. net.

DR. FRIEND'S collection of reports, dealing with various aspects of corrosion, does not represent a complete treatise on the subject. Many important researches and theories are not to be found in it, but the sections of the subject dealt with (including much of Dr. Friend's own work) are treated fairly fully. The subject of the corrosion of iron is one which has occupied man for some thousands of years, and a collected account of further progress will, therefore, be useful. Each investigator has usually emphasised one aspect of the process more than others, and in a "colloidal" theory of corrosion we recognise Dr. Friend's contribution.

*Construction des réseaux d'énergie.* Par M. Daval. (Bibliothèque Professionnelle.) Pp. 275. (Paris: J. B. Baillière et Fils, 1922.) 8 francs net.

M. DAVAL'S work is written for those who have to design or superintend the working of electric power networks. It is written from a severely practical point of view, and assumes only the slightest mathematical knowledge on the part of the reader. The author lays particular stress on those practical points about which the academically trained engineer is often ignorant. The book is clearly written, and will be helpful to the junior staff engaged in the distribution of electric power.

*Les Encres, les cirages, les colles et leur préparation.* Par Maurice de Keghel. (Bibliothèque Professionnelle.) Pp. 384. (Paris: J. B. Baillière et Fils, 1922.) 10 francs.

REFERENCE has already been made in NATURE to an earlier volume of this encyclopedia. The subjects are treated from the technical point of view, i.e. recipes are largely given. Many of these would seem likely to be useful in the laboratory as well as in the workshop, and the book should fulfil the purpose for which it is intended.

### Letters to the Editor.

[The Editor does not hold himself responsible for opinions expressed by his correspondents. Neither can he undertake to return, or to correspond with the writers of, rejected manuscripts intended for this or any other part of NATURE. No notice is taken of anonymous communications.]

#### The Isotopes of Antimony.

OWING to the kindness of Prof. G. T. Morgan, who prepared a specimen of pure antimony trimethyl for this purpose, I have now been able to obtain the mass-spectrum of antimony. The element is characterised by two lines of nearly equal strength at 121, 123. The first is the more intense by perhaps 10 to 20 per cent. If sufficient exposure is given two faint companions are visible at 122, 124, but the general evidence suggests that these are due to hydrogen addition products. The isotopic nature of the lines 121, 123 is amply confirmed by the appearance of similar pairs 15 and 30 units higher, due to molecules of their monomethides and dimethides. The most trustworthy measurements show that the masses of the isotopes of antimony are most probably less than whole numbers by one to two parts in a thousand.

These results show that the chemical atomic weight 120.2 at present accepted is certainly too low. They are, however, in excellent agreement with the value 121.77 recently obtained in America by Willard and M'Alpine. F. W. ASTON.

Cavendish Laboratory,  
Cambridge, November 16.

#### Experiments on the Theory of Soil-acidity.

In a recent paper "On the Adsorption of Ions" (*Phil. Mag.* (VI.) 44, 321) the origin of soil-acidity has been discussed (pp. 338-45, especially pp. 343-45). In the following a short account is given of some experiments carried out with Mr. Kamalacharan Bhattacharya and Mr. Bankim Chandra Roy.

It was suggested that the acidity is due to the adsorption by the gels (of silicic acid, aluminium oxide, and ferric oxide) of the anions of acids. The adsorption is so strong that the adsorbed substance cannot be washed out by water, and the aqueous extract is neutral. The anions are adsorbed on the surface by "chemical forces" whereas an equivalent number of cations forms the mobile second sheet of the double layer. If the cations consist in part of H<sup>+</sup> ions, in treating with excess of a neutral salt (KCl) solution there is a displacement of the cations of the second layer by the cations of the neutral salt, as the latter is present in relatively enormous concentration, and as the forces acting on the cations of the mobile second sheet of the double layer are mainly electrical in nature.

Experiments have been carried out with powdered precipitates of silica, ferric oxide, and alumina. Of these, silica has been found to adsorb appreciable quantities of acids, e.g. acetic, citric, hydrochloric, and nitric. The adsorption is so strong that on repeated washing the adsorbed substance cannot be removed so that the aqueous extract soon becomes perfectly neutral. On now shaking the precipitate with KCl—which is tested with indicators to be perfectly neutral—the aqueous extract (free from particles of the precipitate) is found to be distinctly acid. The amount of the acid depends on the amount of the precipitate. In the extract with the neutral salt solution, acetates or citrates could not be detected.

The formation of insoluble salts of alkali metals or replacement of hydrogen ions by metallic ions in

complex silicic acids is evidently out of the question. It is unanimously agreed that silica is an acid, and the probability of forming definite complex acids with acetic acid is very remote.

It might be argued that the acids are adsorbed as such, that is, the entire molecule is adsorbed. This point has been settled by simultaneous experiments on electro-osmosis. The apparatus used was a modification of that used by Briggs (*Journ. Phys. Chem.* 22, 1918, 256), which the writer found was employed by Dr. Ishikawa in the Physical Chemistry Laboratory of Prof. F. G. Donnan, University College, London. The sample of pure precipitated silica (British Drug Stores, Ltd.) we are using shows a marked negative charge in pure water. On treating with acetate the charge increases as shown by the rate of motion.

The results are accurate within about 10 per cent.

	Velocity in cm. per min.
Pure water . . . . .	2 cm.; 2'05 cm.
N/1000 sodium acetate . . . . .	3'9 cm.
N/2000 acetic acid . . . . .	2'7 cm.; 2'7 cm.
N/1000 sodium hydroxide . . . . .	3'4 cm.; 3'2 cm.
N/100 acetic acid . . . . .	1'7 cm.
N/1000 hydrochloric acid . . . . .	2'3 cm.
N/1000 potassium chloride . . . . .	3'1 cm.

It will be seen that in the presence of sodium acetate and potassium chloride the negative charges increase 100 and 50 per cent. respectively. The experiments have been carried out under identical conditions. In the case of sodium acetate the presence of hydroxyl ions have to be taken into account. It will be seen, however, that acetanions are adsorbed to a greater extent than hydroxidions, and it is well known that the more strongly adsorbed substance largely displaces the other which is not so strongly adsorbed. In the case of potassium chloride the question of hydrolysis does not arise.

As is to be expected from the greater mobility of the hydrogen ions and the views of the writer (*Far. Soc. Disc.*, Oct. 1921, *Phil. Mag.* (VI.) 44, 330-37), the acids of the same concentrations show a smaller charge than their salts. The charge is, however, undoubtedly greater than that with pure water, so that there is unmistakable evidence of the adsorption of anions, but owing to the effect of hydrogen ions the charge indicates a smaller adsorption than is really the fact.

We are at present engaged in working with the gels (which are likely to have greater specific surface) and with chemically pure silica or silicic acid gel. It appears that the electro-osmotic apparatus is also capable of further improvements.

These experiments clearly show that we are really dealing with the kinetic exchange of ions (hydrogen or Al<sup>3+</sup> in the case of soil acidity) in the second sheet of the double layer or present as electrically adsorbed, as suggested by the writer. It is not necessary to assume the hydrolysis of potassium chloride into alkali and acid in water, or the displacement of hydrochloric acid from alkali chlorides by humus acid, or the formation of insoluble salts of alkali metals, as has been done in the past.

There is other corroborative evidence in support of this point of view. J. N. MUKHERJEE.

Physical Chemistry Department,  
University College of Science, Calcutta,  
September 20.

#### New Spectra of Water Vapour, Air, and Hydrogen in the extreme Ultra-violet.

AFTER reading of the excellent work of Prof. Wood on the extension of the Balmer series of hydrogen, I decided to investigate the Lyman series of hydrogen



in a similar manner. In the process of this investigation, some results were found which I now describe.

Water vapour in contact with films renders them insensitive to the extreme ultra-violet, and on the other hand, new films may be made sensitive for immediate use if they are thoroughly dried.

Water vapour gives a spectrum in the ultra-violet extending to about  $\lambda 900$ . It consists of oxygen lines, hydrogen series lines, the secondary spectrum of hydrogen, and some bands probably not due to hydrogen. The A.C. or D.C. current used was found to dissociate water into its elements almost completely. A condensed discharge, however, formed compounds in the receiver of the vacuum grating spectrograph which fogged the films in the path of the light. It is, therefore, not surprising that a spectrum of water vapour should be found in this region of short wavelengths, for hydrogen is known to be transparent here, and the author has shown (*Physical Review*, in press) that oxygen likewise is remarkably transparent in a portion of this region.

With condensed discharge and low pressure in receiver and discharge tube, a spectrum was obtained for air to  $\lambda 350$ . In this experiment no attempt was made to eliminate mercury vapour. Many of the lines in the neighbourhood of  $\lambda 600$ , recently found by Lyman to constitute a helium series, were also found on these films.

Ordinary commercial films were found sensitive at  $\lambda 215.7$ , so that a very clear line was produced on the film after only five minutes' exposure, with hydrogen at a pressure of  $0.3$  mm.

Using wet hydrogen and a long discharge tube three new members of the Lyman series of hydrogen were found. Thus there are now six lines of that series known. Appearing on the same spectrogram with these was a line  $\lambda 243.2 \pm 0.2$ . This was observed on many films, and on some of them it occurred in the first, second, and third orders. Its wave-length agrees within limits of experimental error with the equivalent wave-length ( $\lambda 248$ ) for the L critical potential of oxygen, observed by Kurth, using photo-electric methods. The observation of this line in hydrogen at a pressure of  $0.3$  mm., after the light had traversed a distance of one metre, shows the transparency of hydrogen in this region. This fact may be useful to those working in soft X-rays or in the region of these short ultra-violet radiations. Furthermore, the presence of this line indicates that the great absorption band of hydrogen which begins at about  $\lambda 850$  terminates on the long wave-length side of  $\lambda 243$ .

J. J. HOPFIELD.

Department of Physics, University of California,  
Berkeley, October 30.

### Molecular Viscosity.

THE following remarks are offered rather in the nature of a foreword, suggesting a particular line of research, than as an article of belief. Although the conclusions arrived at are purely theoretical, and have at present no experimental confirmation, the practical test outlined at the end of the paper should supply a definite answer as to whether there is any foundation for the theory advanced.

Our conception of the physical forces which are called into play when a liquid is caused to flow with linear or stream-line motion is gradually undergoing a change. The old definition of viscosity as internal friction needs revising. Already Dunstan and Thole (*Journ. Inst. Petr. Tech.*, vol. iv. p. 197) have come to regard viscosity in the nature of a dual phenomenon, which they attribute partly to internal

friction and partly to deformation of molecular grouping (although these may conceivably be one and the same thing). There is one aspect of the subject which does not seem to have received its fair share of notice. Allusion is made to the gyroscopic resistance offered by any orbits, the motion of which has components at right angles to the line of flow.

When a vapour condenses into a liquid, the molecules still retain the major portion of their high velocity; and since it is only their mutual attraction that prevents them from escaping again into space, it follows that their paths must be very curved, and that in all probability there will be at any instant of time a certain number of them revolving round one another in orbits, after the fashion of the twin stars. These systems would doubtless have only a short life, being destroyed by collision with neighbouring molecules, but for the instant of time during which conditions were favourable similar orbits would be formed to take their place.

For want of a better name this particular form of viscous resistance will be referred to as gyro-viscosity. We may then consider the property, common to all liquids, of resistance to flow as made up of at least two parts, namely:

(a) gyro-viscosity,

(b) molecular friction or deformation.

Whereas (a) lends itself readily to mathematical treatment, (b) is still so largely a matter of conjecture, that while our ideas are in their present state of flux, we cannot be sufficiently definite about anything in this connexion to attempt any sort of analysis. We can, however, be moderately confident that in some degree (a) must obtain, and it is hoped to show a means whereby it may be measured. When a liquid is subjected to a shearing stress, in other words when flow starts, there will be at once the gyroscopic resistance of those components of the orbits at right angles to the line of flow; and when these have been turned through a right angle and flow continues there will remain the constant resistance of those orbits which are produced during flow. Viewed in this way the initial momentary resistance should be greater than the subsequent constant resistance; and since the former is independent of the rate at which the orbits are being formed, it would afford a means of estimating the relative molecular gyro-viscosity, if only it could be measured with sufficient accuracy. A method of doing this which suggests itself is based upon the correct resolution of the forces which go to produce the so-called Couette correction for flow through capillary tubes.

Couette found that when the length  $l$  of the tube was doubled the corresponding time  $t$  was not quite doubled, and that in order to satisfy his equation it was necessary to replace  $l$  by  $l + kd$ , where  $d$  is the diameter of the capillary and  $k$  a constant having an approximate value of  $0.25$ . Since this correction is, in a sense, a measure of the total work  $W_0$  done outside the tube, it must contain also the preliminary work  $W_m$  required to turn all the orbits in existence at any instant of time in the whole volume run. The difference  $W_0 - W_m$  represents the work done outside the tube in overcoming viscous resistance of the liquid already in motion (the kinetic energy correction was, of course, allowed for, and therefore does not enter into these quantities).

The Couette value affords a direct means of determining  $W_0$  but the calculation of  $W_0 - W_m$  presents considerable difficulties. We are faced with the problem of finding (1) an expression for the distribution of the velocities in the trumpet-shaped lines of flow of the liquid before it enters the tube; (2) the varying acceleration of any one of these lines before it attains its final constant velocity on entering the

tube; (3) the influence of the head of liquid on the curvature of these lines. As all of these admit of exact mathematical treatment, it should be possible, by running a gram-molecule of the liquid, to calculate  $W_m$ . This would be entirely independent of the velocity of flow and would represent the relative molecular gyro-viscosity. Whereas the ordinary figures for absolute viscosity appear to bear no general relationship to the other physical constants of the liquid, it is possible that these values might be more productive of results. A thorough investigation of these lines of flow is therefore the first necessary step towards the solution of this most interesting problem.

FRANK M. LIDSTONE.

37 Powell St., Derby,  
November 1.

### New Weights and Measures for India.

I HAVE read with interest the article in *NATURE* of September 2, p. 325, on the weights and measures of India by Mr. Silberrad, president Indian Weights and Measures Committee. Mr. Silberrad reports conditions much the same as I found them in India in 1910. One of the pleasures in reading *NATURE* is that the desirability of producing commodities and methods of service is taken for granted. Now in attacking this problem it is assumed that a simple, useful system of weights and measures is desired for India. While in India I was asked to rewrite the article on weights and measures for the "Times Year-book," and in looking up data in this connexion, I came across the permissive Metric Act of 1871. This Act represents one of the attempts of the leaders of India to secure the advantages of the general use of the metric system. By it the Viceroy of India is empowered to make what preliminary arrangements might be necessary, and proclaim the date after which metric weights and measures shall come into general use.

Let us consider the various necessary units of measurement in their logical order.

1. Mr. Silberrad rightly mentions "the Peshawari yard of 38 in. to 38½ in.," and also the yard of approximately 40 inches. Also the *Ilahi gaz*, which is frequently in the neighbourhood of, if not exactly, 39-37 inches or one metre. These are only a few examples of units of length in a country of approximate lengths that could be best standardised on the international metre.

2. Practically the same thing is true of measures of area. Nearly all of the British engineers that I have met have favoured the metric system, and few have any desire to continue the use of such a difficult unit as the acre. The square metre and the hectare of 10,000 square metres are good and sufficient, and will, we believe, be used eventually in all civilised countries. Several of the Indian units fortunately approximate to the hectare.

3. The suggestion that "the standardisation of suitable measures of capacity at the nearest suitable multiple of the bulk of 1½ seers of water, this being approximately equivalent to the bulk of a seer of wheat," is not so unfortunate as it may seem. This probably will soon become the litre.

4. My findings also correspond with those of Mr. Silberrad in reference to the *tola* of 180 grains, about 12 grams. This brings the seer to approximately 1 kilogram. When it is understood that the seer has been adopted for practically all railroad transactions in India by the British Government, one realises that India is using the metric system in what amounts to 60 per cent. of all accurate transactions according to weight.

It was my pleasure to spend part of the past summer in England, and confer in regard to the metric campaign with members of the Decimal Association and others who are actively interested in the metric movement. I found a general desire to secure the advantages of decimal currency and metric weights and measures. It was forcibly brought home to me that the chief men of England who have the vision of service and big foreign trade will not only encourage the Colonies to make progress in the metric movement, but will also see to it that the British Government leads the way in this much-needed reform. Readers of *NATURE* will be interested to see the following statement by Prof. J. C. McLennan of Toronto University: "In the early part of 1906, at the request of the Hon. L. P. Brodeur, Minister of Inland Revenue of the Dominion Government of Canada, I agreed to deliver a number of lectures on the use of metric weights and measures.

"Through the co-operation of the Department mentioned, a schedule of the lectures was arranged, and it was made known in various centres throughout Canada that my services in connexion with the metric campaign would be available on certain dates for the various local societies interested in this subject.

"In carrying out this rather strenuous schedule, lectures were given in Montreal, Ottawa, Toronto, Winnipeg, Regina, Vancouver, and in over 30 other Canadian cities. In some places the idea of the simple metric system corresponding to decimal currency was then new to many people. Our meetings were well attended, in some cases as many as 600 people being present. At the close of each address, all present were invited to take part in the discussion of the subject. The pros and cons were propounded with the utmost frankness, and in some cases with considerable vigour. Never during this lecture tour or at any other time have I heard, in so far as I can judge, a really valid argument against the general use of metric weights and measures. On the other hand, the many valid reasons for their use increase as time passes.

"It is highly desirable that this preliminary educational work, conducted entirely at the expense of our Government, should be effectively followed up. It is chiefly for the purpose of encouraging others to do their part in securing for Canada the advantages of the use of the metric system that on April 28, 1922, I accepted the Chairmanship of the Toronto Section of the American Metric Association. At that time Mr. W. P. Dobson of the Hydro-Electric Power Commission was elected Secretary, and Mr. L. Burpee, of the Canadian General Electric Company, Ltd., was elected Treasurer. Our Section is composed of volunteer workers, who desire to see the metric campaign progress as it should. We believe that everybody can do something to help. We hope that a great many people will let Mr. Dobson know that they will help the metric movement in their own industry or line of work."

It may seem a far cry from Canada to India, but there is a direct connexion when one realises that the various peoples of the world can understand and serve each other best when they use the same convenient weights and measures. The members of the American Association are determined to secure these advantages in the United States and Canada, and we ask for the hearty co-operation of all progressive men and women throughout the world.

HOWARD RICHARDS  
(Secretary).

American Metric Association,  
156 Fifth Avenue, New York.

By the courtesy of the Editor I have read Mr. Richards's letter, and think that he and I disagree solely by reason of the difference in our Indian experiences. If it were a case of starting with a clean sheet there would be no greater difficulty in adopting the metric system than in adopting any other; but this is not the case. The British yard *has become* very widely known, whereas the metre is quite unknown. The Peshawari yard and the Ilahi gaz, themselves variable units, are used only to a comparatively small extent, while the most widely known unit of length, the hath or cubit, is very near to half the British yard, and as a matter of practical fact this measure is regarded as representing it exactly.

Similarly, the acre *has now become* very widely recognised and used as a unit of area, while the hectare has scarcely even been heard of.

It is true that the 80-tola seer (of 14,400 grains) is near the kilogram, but it is not exactly equal thereto, and to change it would, as a matter of practical fact, involve altering the weight of the rupee, as that coin is universally recognised as representing in weight 1 tola. This question of changing the weight of the rupee so as to give a seer of exactly two pounds, or else of 1 kilo, was one that the Weights and Measures Committee considered very carefully and on which it recorded much evidence, and (the majority of the members) reluctantly came to the conclusion that any alteration—whether in weight or value—of that coin would give rise to so much suspicion as to make it more than doubtful whether such a change would be worth while.

It has taken fifty years to spread the knowledge of the 80-tola seer to the extent now achieved; to introduce a new unit would mean starting all over again, and the same remark applies to any change in the units of length or area.

I have no doubt that engineers would prefer the metric system—so would I, personally. But the people of India are not engineers. Ninety per cent. of them live in villages or small towns of less than 5000 inhabitants, and are only interested in weights and measures being true and uniform within the limited range of their journeyings. For one transaction in which it would be an advantage to use a world-wide system, there must be at least 10,000 in which it would be of not the slightest advantage.

Mr. Richards refers to Canada. I imagine that it would be difficult to find two peoples more absolutely different than those of Canada and of India; the Canadian is well educated and progressive, the Indian, as a rule, very poorly educated, and intensely conservative. It would be difficult to conceive of widespread lecturing on weights and measures in India; audiences might perhaps be secured in half a dozen of the largest towns, but nowhere else, and the population of India is more than thirty times that of Canada. (I do not wish to imply that Mr. Richards thinks lecturing advisable, but merely to emphasise the difference between the two countries.)

My own experience of India at the time of the Weights and Measures Committee was twenty years in the Civil Service, all on the executive side, in the course of which I usually spent four to six months every year on tour among the villages and small towns of my district; that of my Indian colleague on the Committee (who shared my views, with very insignificant exceptions) was very similar. With this experience we disagreed from our other member, and held that there were not sufficient advantages attached to the metric or other non-Indian system to justify us in making a recommendation which, if accepted, would affect the method of carrying out

an enormous number of petty transactions, and could be given practical effect only by a large amount of interference. Now interference of such a kind as would be required to enforce the use of a new system of weights and measures means interference by a large and therefore necessarily low-paid staff, and what that means any one with Indian executive experience knows, for though the head of the Indian Government colossus *may* be golden, its feet *are* very certainly still decidedly argillaceous!

In brief, we found a very general desire for a uniform system of weights and measures, but for one based on a unit that was known, and hence we recommended that system which could be adopted with very much less difficulty than any other.

C. A. SILBERRAD,  
President Indian Weights and Measures  
Committee, 1913-14.

#### Harpoons under Peat in Holderness, Yorks.

ON page 481 of NATURE for October 7, Mr. O. G. S. Crawford states that he believes one of the alleged harpoons said to have been found under the peat in Holderness to be genuine. At the Hull Meeting of the British Association he thought that both were genuine. After the spade-work to which he refers, I feel satisfied that he will consider both of them are modern. I am also glad to learn that he now regards the evidence supplied by the flint axe to be of no value, whereas formerly he considered that it helped to prove the great age of the harpoons.

As one who knows Holderness fairly well, I should like to ask what evidence there is for the statement that "There can be little doubt that in Holderness exist remains of the early neolithic age, remains which are older than the Long Barrows"? At Hull we were promised that a committee should be formed to inquire into the question of the harpoons. I have heard nothing further about it, but trust such a committee may be called together.

If I have cast doubts upon the authenticity of implements which have been accepted as genuine by quite a number of authorities, and my doubts prove to be unfounded, I deserve censure. If, however, the statement I made proves to be correct, the facts should be published, in the interests of truth.

Reasons for my belief are given in a communication which I sent to the Editor of *Man* a little while ago, as Mr. Armstrong's illustrated description of the harpoons first appeared in that journal. I do not remember having made the statement in public that the harpoons had been "*made* by the supposed finder." I did say they were not as old as Mr. Armstrong.

T. SHEPPARD.

The Museum, Hull.

#### The Relationship between the common Hermit-crab (*Eupagurus bernhardus*) and the Anemone (*Sagartia parasitica*).

THE relationship between the common hermit-crab (*Eupagurus bernhardus*) and its messmate anemone *Calliaetis* (*Sagartia*) *parasitica* has long been a subject of much conjecture, owing largely, the present writer thinks, to the unnatural figures of these animals in all the text-books and most popular books—derived probably from old and abnormal aquarium specimens. In most figures purporting to show the relationship of these animals, the anemone is shown with its tentacles beautifully expanded and the mouth region facing upwards away from the ground, and generally

also one anemone as the central figure sitting on the top of the shell—containing the hermit-crab—with its column extending high above the shell and crab.

When these hermit-crabs with their associated anemones are caught fresh in the trawl it may be observed that although the anemones come up closed in no case are they sitting on the shell as is shown in the well-known figures; on the contrary, whether there is only one or as many as three anemones on a shell they are all found to be either hanging from the shell with the disc region towards the ground or are straining their bodies to reach their discs over the side of the shell towards the ground (see Fig. 1). In order to obtain more information, a collection of fresh hermit-crabs and anemones was obtained by trawling in September 1920 and a few experiments made in a tank. The hermit-crabs and anemones were isolated and kept without food for a few days, in the course of which most of the anemones closed. At 11.30 A.M., September 22, the crabs, carrying altogether 18 anemones, were fed with cockles and queens. At 12.5 P.M. all anemones were open with their discs and tentacles spread flat out on the bottom of the

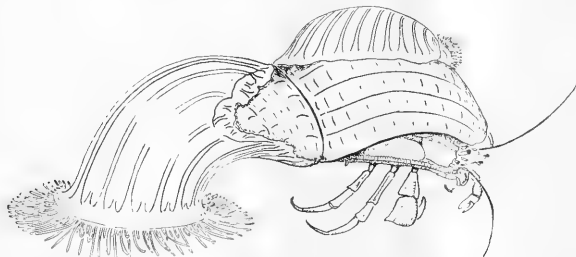

FIG. 1.—Drawing from life of the Hermit-crab (*Eupagurus bernhardus*) in a shell of the common whelk with two anemones (*Calliactis parasitica*) shown in the natural feeding position, and with the commensal worm (*Nereis fucata*) in the act of taking food out of the jaws of the hermit-crab. (About half the natural size.)

tank (as is shown in Fig. 1) and being trailed about in this position by the crabs. At 10 A.M., before the feeding, two anemones were closed, three already had their discs on the ground, and thirteen were held horizontally from the apical region of the shell-house of the crab, and at 1 P.M., after feeding, many were again closed or with their bodies held horizontally. On September 29 the experiment was repeated, but this time fresh dredgings only were thrown into the tank. All the anemones soon put their discs flat on the ground, and those which were sitting horizontally bobbed their discs down on the ground within a few minutes, almost as though the order "heads down" had been given and obeyed. It was not possible to see whether the unusual movements of the crabs on the addition of food, or the smell of the added food, caused the anemones to react as they did.

On adding the food to the tank it was also observed that the worms (*Nereis fucata*) living in the shells inhabited by the hermit-crabs also came out to feed. The hungry worms came out cautiously some time after the hermit-crabs had begun to feed, and in one case a worm was observed to crawl alongside the body of the crab (see Fig. 1), over the active mouth appendages, and literally to take with impunity a piece of food from between the jaws of the crab and bolt it. There seems to be little doubt that this action of the worm is consciously tolerated by the hermit-crab, as it was observed that the crab can apparently control the exit of the worm from the shell. It was found, however, that strange

worms taken from other hermit-crab shells are not regarded in a kindly manner by either the anemone or the crab: worms fed to anemones are eaten, and worms straying in the neighbourhood of hermit-crabs were mercilessly torn up and tasted but rejected as food. The spectacle of a hermit-crab cleaning itself after feeding is a revelation of the value of spines and hairs and of the meticulous cleanliness of these animals, and cannot fail to impress the observer with the pleasure—and even mild intoxication—experienced by the hermit-crab from the feed.

It is clear that the anemone derives advantage from the hermit-crab by getting dragged about with its tentacles on the ground and being given opportunities for picking up pieces of food left or lost by the hermit-crab and for capturing other animals as food. The hermit-crabs were not seen to pass on pieces of food definitely to the anemones, but there would always be a good chance of an anemone getting some food from the table of the hermit-crab, owing to the habit of the latter of tearing the food apart.

The crab itself probably derives some measure of protection from attacks from fishes owing to the unpleasantness of its associated anemones as food, but it is well known in this laboratory that the common ballan wrasse (*Labrus bergyllus* (*maculatus*)) will watch its opportunity to seize a large claw of a hermit-crab and shake it—like a dog worrying a rat—with the common result of extracting the whole hermit-crab out of the shell-house without touching the anemone.

The function of the worm in the shell can scarcely be guessed at, but the curious and constant wave-like motion of the whole body of the worm—which can be seen by making a window in the shell—will certainly keep up a strong current of water around parts of the body of the hermit-crab, and may assist the hermit-crab in this way in the aeration of its body or in the removal of effete products. The advantage to the worm of obtaining shelter and of partaking of the hermit-crab's food is obvious.

J. H. ORTON.

Marine Biological Laboratory, Plymouth,  
November 9.

### First Lessons in Practical Biology.

AFTER being encouraged by favourable criticism, both from the Press and from private individuals (not in all cases personal friends), I was somewhat surprised at the acerbity of the attack, published in *NATURE*, November 4, upon my unpretentious book "First Lessons in Practical Biology." Helpful criticism is welcome to an author, and the correction of errors can be the making of a second edition of a text-book; but adverse criticism in which personal bias of opinion is allowed to outweigh generally accepted beliefs can have little value either for the author or for the reading public.

If "the telson is *not* a segment" I am consoled by the thought that two such standard works as "Practical Zoology" (Marshall and Hurst) and "Biology" (Parker) contain the same heresy. If "the biramous appendage is *not* the primitive form of crustacean appendage" I have still to read a more convincing argument than that given in the "Cambridge Natural History (Crustacea)."

I conclude that the critic was so pained by my restricted use of the term "embryo" (as applied to plants) that he failed to read to the end of the chapter; otherwise he would not have stated that "experiments on plant physiology are not reached until chapters 16 and 17." I agree that it is desirable to introduce plant physiology at an earlier stage in the course; but, with the exception of *germination* (which is introduced in the Easter Term), the experiments seldom yield good results in the winter months. The school year begins towards the end of September, and the arrangement of the chapters (as stated in the preface) was based upon this assumption. E. W. SHANN.

Oundle School, November 10.

I REGRET that Mr. Shann regards my review of his book as an "attack," and yet more that it calls from him the word "acerbity." The need for brevity compelled, perhaps, a certain bluntness; and I beg him to accept my assurance that it was solely to my regard for space in your columns that any such bluntness was due. It was from like considerations that I was obliged to refrain from indicating the authority for and adducing evidence in support of some of my criticisms.

With regard to the telson and biramous appendage I adhere to my statement. If Mr. Shann will refer to p. 144, § 2 c of Marshall and Hurst (9th edition, 1920), he will see that the telson is spoken of as a "region" of which a "segment" is a part. On referring to the passage in my copy of the "Cambridge Natural History" I find that when I first (presumably in 1909) read its discussion of the relative claims of the biramous and foliaceous limb to be regarded as "primitive," I wrote in the margin "All the facts here stated, if taken in the reverse order, support the opposite theory." This is equally true to-day. If Mr. Shann will read H. M. Bernard's "The Apodidae" (Macmillan, 1892) I shall be astonished if he does not abandon the biramous as the "primitive" form of crustacean limb.

I duly noted that the course was arranged with the view of beginning in the Michaelmas Term; but as the very next sentence in the preface suggests modification of the order "at the discretion of the teacher," I felt justified in directing attention to the tardy appearance of plant physiology. The fact that some physiological experiments occur as early as chapter 14 does not seriously affect my criticism.

THE REVIEWER.

### The Mechanism of the Cochlea.

IF I understand Dr. Perrett's letter in NATURE of November 11, p. 633, his objection to Yoshi's experiments (which would apply equally to those of Wittmaack and Siebenmann) is based on the assumption that the intensity of the stimulation of every part of the cochlea must be proportional to the amplitude of the vibration set up in that part. I think this assumption is unwarranted, as the intensity of the sensory impression may vary also with the rapidity and the rate of change of direction of the movement imparted to the cilia of the hair-cells; *i.e.* as the total energy of the stimulus, not its amplitude only. Even supposing Dr. Perrett's assumption were correct, still Yoshi's deductions are not invalidated. Take the case in which he found that after prolonged subjection to high-pitched noise the basal portion of the cochlea showed degeneration. He deduces the logical conclusion that a high-pitched note

stimulates the basal portion of the cochlea. It does not matter whether the stimulus thus applied were small as compared with that produced in the apical region by a prolonged low note or not. The apical region remained unaffected because it was not stimulated at all.

I cannot say that my model shows the shifting of the responses according to the intensity of the stimulus that Dr. Perrett says it should do, and possibly my knowledge of physics is insufficient to enable me to appreciate the reasons which lead him to look for this result. Personally, I have very little faith in the "crucial test" method of solving the problem of sound perception. The question has already been so long and so keenly debated, and so many "crucial tests" have been applied on both sides of the argument, that one almost begins to doubt the possibility of tone perception at all.

I have read Sir William Bayliss's letter (p. 632) with great interest. Naturally, it is very gratifying to me to find that my view of the mechanism of the cochlea has the support of so distinguished a physiologist. I am not very sanguine that my model will throw much light on the more refined details which he gives of the working of the cochlea. What the model actually shows is a definite, though not always well-defined, series of responses at different points along the "basilar membrane" for vibrations varying in frequency from about 100 to about 1000 D.V. per sec., the higher notes being at the proximal and the lower at the distal end of the scale. More than this I cannot claim for it. The mechanical difficulty of setting up a series of short threads, evenly spaced, evenly graduated in tension, and maintaining their spacing and tension unaltered during and after the processes of fixation, embedding and immersion in fluid, is so great that I have not succeeded so far in attaining anything approaching accuracy.

One need scarcely say that so imperfect an apparatus cannot, in its present state, throw much light on the more recalcitrant points. If on the other hand we concentrate our attention on the more obvious, and more fundamental factors, I think the model does give some help. We recognise in the basilar membrane of the cochlea a threefold differentiation of its fibres, for length, tension and mass, and this differentiation is progressive, and in the same sense for each factor. We can embody those mechanical factors crudely in the form of a working model, and we get some sort of remote and inaccurate representation of what happens in the cochlea. The effects observed are undoubtedly resonance effects. It follows that the same resonance effects must take place in the cochlea. One cannot understand how Nature could evolve so elaborate a mechanism of resonance as we find in the cochlea, except by means of, and for the purpose of, increasingly accurate analysis of sound.

G. WILKINSON.

387 Glossop Road, Sheffield, Nov. 15.

### An Offer of Nature Volumes.

THE WRITER has been entrusted with the disposal of thirty-three volumes of NATURE (unbound, as issued) which their owner wishes to present to some library in the war-devastated area. These consist of vols. 50 to 56, 74 to 92, 97 and 98, and 103 to 107. A few parts are missing. Should any reader of NATURE know of some one who may be communicated with for this purpose, the information would be gratefully received.

M. GHEURY DE BRAY.

40 Westmount Road, Eltham, S.E.9.

November 13.

## Human Blood Relationships.

THE idea that a loss of blood by hemorrhage or the possession of blood of a poor and deteriorated quality might best be rectified by the introduction into the body of blood from a healthy person is of respectable antiquity. It is small wonder that the ancients attributed to so splendid and conspicuous a tissue an importance rather beyond its due. About the time of the fire of London Pepys attended experiments in which the blood of one dog was passed into another and found to be sufficient for its needs, and on another occasion at which a man was hired for a sovereign to have some sheep's blood let into his body. For even at this time it was realised that some sorts of blood were more suitable for transfusion into man than others. Little boys might be bled to death in the fifteenth century to provide stimulating potions for aged Popes, but human blood seems scarcely to have been available in Lower's time, and the choice generally fell on the sheep, partly because of its gentle and amiable disposition and partly "quia Christus est agnus Dei," as Coga said, an indigent bachelor of divinity who subjected himself to the experiment in 1667. But transfusion of blood never became an important or popular therapeutic procedure on these terms; large quantities of foreign blood were found to cause serious and even fatal ill-effects and small amounts did no good. With the discovery of the last thirty years that the tissues of any one species of animal are foreign and more or less poisonous to the economy of any other species came the recognition that transfusion in man could be done only with human blood, and in recent years the value of the procedure has been fully established, large quantities being transfused from a healthy to a sick person without untoward effect.

In this revival of human transfusion it was, however, soon found that the capacity of the body to identify any blood as foreign to and incompatible with its organisation was based on finer distinctions than zoological species. If from a dozen people a few cubic centimetres of blood are withdrawn, and in each case preparations made of the serum and of the red corpuscles washed free from serum, and if a sample of each lot of corpuscles is then mixed with a little of each serum in a series of test-tubes, it will be found that the results are not all the same. In some the corpuscles behave as if they were suspended in physiological salt solution—remain dispersed from one another and intact; in other cases they run together into larger or smaller clumps and masses and often disintegrate. It is obvious that the occurrence of this agglutination in the circulating blood is very undesirable, as the masses of corpuscles are liable to block important blood-vessels, and there is plenty of experience to show that serious trouble may be caused in this way. It is therefore not every human blood that is suitable for transfusion into a given person.

By sorting over a large number of people by this test it has been found that they may be classified into four groups by the satisfactory hypothesis of von Dungen and Hirschfeld. On this view there are two agglutinating factors in human blood serum (*a* and *b*) and two agglutinable factors (A and B) in

human blood corpuscles: A corpuscles will react only with *a* serum, *b* serum only with B corpuscles. A is never found in the same person as *a*, nor B with *b*; either combination would be incompatible with life. The blood characteristics of the four groups are:

	Serum.	Corpuscles.
Group I. . . .	neither	A and B
Group II. . . .	<i>b</i>	A
Group III. . . .	<i>a</i>	B
Group IV. . . .	<i>a</i> and <i>b</i>	neither

It follows that the serum of Group I. will not agglutinate anybody's corpuscles, while the corpuscles of Group I. are agglutinated by all other sera except their own. Group IV. is the reverse of this, while the serum of Group II. agglutinates the corpuscles of Groups I. and III., and the serum of Group III. the corpuscles of Groups I. and II. The corpuscles of Group I. can safely be put only into recipients belonging to the same group, those of Group II. only into Groups I. and II., those of Group III. only into Groups I. and III., those of Group IV. into anybody. It is a curious fact that in actual practice it is only the qualities of the donor's corpuscles and the recipient's serum which need be considered. When, for example, Group IV. blood is transfused, the plasma of it should agglutinate the corpuscles of the recipient if the reaction took place as it does outside the body. This does not appear to happen, or if it does it produces no obvious ill-effects—which is fortunate, as otherwise safe transfusion would be impossible except between members of the same group. Why this should be so is at present doubtful. It is most probably due to the quantity of transfused plasma being insufficient, when diluted with the recipient's blood, to cause a significant agglutination of the recipient's corpuscles. The fact that it is plasma which is injected and not serum may also have some influence, though the recipient's plasma has the same effect as his serum, at any rate qualitatively.

While it is convenient to recognise four varieties of individuals, it will be seen that there are only two factors concerned. A is characteristic of Group II., and B of Group III.; A+B are present in Group I., and both are absent in Group IV. A corpuscles are necessarily associated with not-*a* serum, and B corpuscles with not-*b* serum. In inheritance these qualities have been shown to be transmitted as straightforward Mendelian factors. It follows that the blood of parents and children are by no means necessarily compatible: though parents both of Group IV. can produce children only of the same group, two Group I. parents may have offspring belonging to any group, according to the particular composition of their hybridity. The possibility of using these blood reactions to investigate cases of disputed parentage has been carefully worked out by Ottenberg, who shows that the method can have but a limited application, though the answers are conclusive if they can be obtained at all. Of much interest also is the observation that the proportion of the population falling into Groups II. and III. varies a good deal in different races. In England about 40 per cent. are Group II., about 15 per cent. Group III., Groups I. and IV. giving about 2

and 43 per cent. respectively. Several workers, and especially the Hirschfelds, have shown that as one travels from west to east the prevalence of Group II. (A) decreases and that of Group III. (B) progressively rises. In Western Europe, A is found in about 45 per cent., in Russians and Arabs in 37 per cent., in negroes and Indians in 27 per cent. B, on the other hand, increases from about 15 per cent. in France, through the Balkans (20 per cent.), Malagasies (28 per cent.), negroes (34 per cent.) to Indians with 49 per cent. We have here an obvious suggestion of two original races of mankind, which have mingled in various degrees: it is possible that in some remote place a pure A or B variety still exists.

At present there is no evidence that these blood

characteristics are associated with any other qualities, and it seems likely, like some other Mendelian characters, that they are negligible in the problems of selection and survival. It would, too, be an error of the ancients to suppose that the qualities of the blood dominated personality and conferred a general characteristic on the individual. There is much evidence of the essential similarity of parents and offspring. The greater success of grafting tissues from one animal to another if they are of the same family is a germane example. In blood tests brothers and sisters by no means always agree so far as the agglutination of their corpuscles is concerned: in other respects their bloods are probably more similar than those of more remote relations.

### The History of the Photographic Lens.

DR. REGINALD S. CLAY performed a needed and useful service when he selected for the subject of the twenty-fifth annual Traill-Taylor Memorial Lecture, which he delivered at the meeting of the Royal Photographic Society on October 10 last, "The Photographic Lens from the Historical Point of View." It was a needed service, because a historical review of the origin and development of the photographic lens is necessary for a just estimate and balanced perspective of the many and diverse scientific factors that have to be taken into account in the production of modern photographic lenses. It was a useful service, because the fascinating and, at times, almost dramatic story that Dr. Clay had to tell brings out clearly the paramount importance of the pioneer work done in this field by British firms and scientific workers, and it must act as a useful corrective to the tendency, sometimes manifested in unexpected quarters, to underrate the value of British work in the optical field.

After touching lightly on the early history, Dr. Clay comes to "one of the great landmarks in the history of optics—the invention of the achromatic lens." John Dolland, after numerous experiments, exhibited to the Royal Society an achromatic prism in 1758 of crown and flint glass, and explained its construction. Of the authors who contributed, in this period, before the invention of photography, to the theoretical treatment of the lens, Dr. Clay instances, after Kepler, the following:

Huygens, who, besides expounding the wave theory of light and the explanation of double refraction, also dealt with the spherical aberration of lenses, and showed how it varied with their aperture and focal length; Newton, who investigated the dispersion of light; Joseph Harris, who discussed the cardinal points, optical centre, oblique pencils, curvature of field, etc., in his "Treatise of Optics"; Herschel, who obtained valuable equations for the calculation of objectives free from chromatic and spherical aberration; George Biddell Airy, who investigated the conditions for eliminating astigmatism and distortion; William Hamilton, who evolved powerful mathematical methods which even yet have not been fully utilised; and, last but not least, Henry Codrington, who worked out the methods which, I believe, still form one of the most useful bases for attacking new problems in lens construction.

The next milestone marks the almost simultaneous announcements of the inventions of photography by

Daguerre in 1838 and Fox Talbot on January 30, 1839, and we reach "the epoch from which we may date the great evolution of the photographic lens." After referring to the photographic lenses of Charles L. Chevalier, Dr. Clay comes to the work of Josef Max Petzval (1807–1891), who computed a new and most successful lens, corrected for spherical aberration over a small angular field, which was made by Frederick Voigtländer in 1840.

We may pass over much interesting record and come to a new chapter, opened in 1866 with the aplanatic lenses of Steinheil and Dallmeyer. Steinheil, "beginning to recognise the value of symmetry in reducing astigmatism and distortion," concluded that the astigmatism would be less if the refractive indices of the glass were more nearly equal; he therefore used two flints instead of flint and crown, putting the higher refractive glass outside. Dallmeyer also used two flints, and called his first lens a "wide-angle rectilinear lens," 1866. It worked at  $f/15$ , and he followed it by his symmetrical at  $f/7$  and  $f/8$ . In 1874 Steinheil made a portrait lens of two cemented lenses working at  $f/3.5$ , and in the same year Ross brought out their portable and rapid symmetrical, calculated by F. H. Wenham. "This is of interest," says Dr. Clay, "as Ross and Co. (as the firm then was) was thus the first firm to employ a scientific man as calculator. Wenham was with them from 1870 till 1888."

The next step, which Dr. Clay describes as "the greatest step in the development of the photographic lens," was made possible by the new glasses—the barium crowns of the Schott glass factory at Jena. The problem and its solution is thus expressed:

An achromatic lens of ordinary crown and flint, which we may call an "old achromat," could be corrected spherically, but not made anastigmatic. An achromatic lens made of the new barium crown and a flint could be corrected for astigmatism, but not spherically. To correct both, all three glasses must be used—old crown, flint, new barium crown. To take full advantage of this principle, it is obvious that each component can be made of all three glasses. It can then be achromatic, anastigmatic, and aplanatic. By combining two such components into a symmetrical lens, it can also be made orthoscopic, and can easily be given a flat field. This is the principle underlying the well-known Goerz lenses. Another way to achieve the result is to use two unlike combinations, one of which is made responsible for

correcting the spherical aberration and the other for correcting the astigmatism. This is usually the method adopted by Rudolph in the earlier of the Zeiss lenses and several of the recent lenses by other makers.

Hugo Schroeder and Stuart, of Ross and Co., were the first to take advantage of the new Jena glasses, and in 1888 they patented the "concentric" lens, composed of a flint and a barium crown. It was corrected for astigmatism, but had a lot of spherical aberration. Dr. Clay reviews briefly the series of Zeiss lenses—Planar, Protar, Unar, and Tessar—made by Ross under license, and in this connexion tells the following significant story:

In 1911, when Zeiss had finished their factory at Mill Hill, they gave Ross notice to terminate the license, and themselves made the Tessar—the only one of which the patent was still running. This is rather an illuminating fact. It must be remembered that in 1892, when Ross started making the Zeiss lenses, Ross had a great name as makers of photographic lenses, while Zeiss's were practically unknown in that connexion, and undoubtedly Ross's reputation helped to make the new lenses known; yet no sooner are Zeiss ready to make their lenses over here than they terminate the contract! No further comment is necessary.

An interesting summary follows, which we have not space to notice in detail, of a brilliant series of lenses produced by Ross from 1892 to the present day. Dr. Clay says: "One other achievement of this firm I must refer to. When the Air Force began to take aerial photos in the war they found the Ross-Zeiss Tessar, of 8½-in. focus, suitable, but soon wanted great numbers, and also asked for a longer focal length lens with perfect definition over a small angular field, e.g. a 20-in. lens to be used with a 5 by 4-in. plate. This was wanted urgently, and in a single fortnight the lens was recalculated, and the 'Airo-Xpres' lens evolved in November 1918, working at f/5.6. Messrs. Taylor, Taylor and Hobson also made a variety of the Cooke lens, the 'Aviar,' for the same purpose."

We have not space to deal more than hurriedly with the fascinating record that Dr. Clay gives of the other work done in Britain in the development of the photographic lens to its present stage of wonderful achievement. An interesting account is given of the lenses introduced by the firm of Dallmeyer, and special attention is directed to the striking advance represented by their telephoto lenses. The original patent for the telephoto was taken out in 1891. Another English firm, R. and J. Beck, Limited, it is interesting to note, were the first to apply the iris diaphragm to photographic lenses, as early as 1882. In 1906 Beck introduced their "Isostigmat Universal," and in the

following year their Isostigmat portrait lens. "These lenses do not obey the Petzval condition—that the sum of the power of the lenses, divided by their refraction index, should be zero—and were constructed by omitting this from consideration, as they believed it was not essential for a flat anastigmatic field"—a view afterwards confirmed by the investigations of W. Elder. The Isostigmat is of interest, as it covers a field of 85 to 90 degrees at f/16, the first wide angle with such an aperture. Beck also introduced another simple idea—the use of magnifiers in front of a lens—made for their Frena camera in 1894.

We have left till the last not the least of the British achievements in the development of the photographic lens—the Cooke lens invented by W. H. Dennis Taylor and made and put on the market by Taylor, Taylor and Hobson, Limited. Dr. Clay says: "I do not think the great step which the Cooke lens marks is as well appreciated here as on the Continent. The introduction of this lens has formed the starting-point for a new method of lens construction which has had, and will continue to have, many fruitful applications." The germ of the invention is thus expressed by Dennis Taylor:

It . . . occurred to the author that since the normal curvatures of images due to any lens, whether simple or compound, are fixed by its refractive indices and power alone, and are independent of the state of rays entering the lens, whether convergent, divergent, or parallel, then it should follow that the normal curvature errors of an achromatic and aberration-free collective lens should be neutralised by the normal curvature errors of an achromatic and aberration-free dispersive lens of the same power (and made of the same glasses), placed at a considerable distance behind the collective lens; while the combination would, as a result of the separation . . . yield a positive focus. . . .

The patents for the Cooke lens were taken out in 1893, 1895, and 1898. During the war the special Aviar lens, referred to above, was evolved, designed by Arthur Warmisham of Taylor, Taylor and Hobson. It is a split-divergent lens, which was a conception of the inventor of the Cooke lens, but the exploitation of the idea was left to Warmisham, who was able, by making a special study of coma, to improve upon the large aperture Cooke lenses, and secure a flat field of larger area than had hitherto been found possible.

In a brief review of Dr. Clay's lecture we have had perforce to omit much of important interest, but we may conclude by re-echoing the words of the author: "In this story I think we in Britain may claim that we have borne our share, in spite of all the praise that has been lavished on the Germans."

## Obituary.

PROF. HEINRICH RUBENS.

HEINRICH RUBENS was born at Wiesbaden on March 31, 1865, and received his early training at the *Realgymnasium* at Frankfurt on the Main, where he gained the School Leaving Certificate, equivalent to Matriculation, in March 1884. In the summer term of that year he proceeded to the Technical High School

at Darmstadt to take up the study of electro-technics. During the following winter term and the summer term of 1885 he continued his studies at the Technical High School at Charlottenburg, but soon recognised that his ability and interest lay in the domain of pure science, and for this reason he began the study of physics. After spending the winter term (1885-86) at the University of Berlin, Rubens passed on to Strass-



bourg at Easter of the latter year to work under August Kundt. He followed Kundt to Berlin in May 1888, and obtained his Ph.D. there the year following. His early post-graduate career was spent as *Assistent* under Kundt at the Physical Institute of the University of Berlin, where he remained until 1896, when he was invited to the Charlottenburg Technical High School, and in 1900 he was officially elected professor at that institution. In the autumn of 1906 he was elected to a full chair of experimental physics at the University of Berlin, and to the directorship of the Physical Institute, which posts he filled during the remainder of his life. He died of leuchæmia on July 17 last.

Rubens was a member of the Berlin Academy of Science, and of many other similar bodies in his own country and abroad, including the Royal Institution, of which he was an honorary member. He held doctor's degrees (*honoris causa*) of the Universities of Leeds and Cambridge, and was a recipient of the Rumford Medal of the Royal Society.

Most of Rubens' scientific investigations were concerned with the infra-red region of the spectrum, and the logical connexion of his numerous researches is a noteworthy feature of his scientific activity. Many of the instruments used in the prosecution of his work were of his own construction, including the Rubens thermopile, and the Rubens-Du Bois spherical sheath galvanometer. He was led to the discovery of residual rays as a result of his work and measurements on the optical properties of various substances with regard to heat rays. He succeeded in reducing the previously unexplored region of about twelve octaves (from  $\lambda = 0.005$  to 50 mm.) between the infra-red region of the spectrum and electrical waves, by his discovery of about seven of the missing octaves.

After his observation that a number of minerals strongly reflect infra-red waves of certain definite wave-lengths, and transmit the rest of the rays, Rubens was able to isolate rays up to a wave-length of about 0.01 mm. Repeated reflection of the radiation from such surfaces results in a residual radiation which contains certain definite wave-lengths only; e.g. from fluorspar (0.022 and 0.033 mm.), rock salt (0.052 mm.), sylvine (0.063 mm.), potassium bromide (0.083 mm.), potassium iodide (0.094 mm.). In part collaboration with Wood, Rubens isolated still greater wave-lengths by the quartz-lens method, in which, by virtue of the higher refractive index of quartz for these long waves than for the shorter infra-red and visible rays, and by the use of suitable diaphragms, he succeeded in obtaining rays with a wave-length of about 0.110 mm. from an incandescent mantle. Using a quartz mercury lamp he extended this limit to beyond 0.3 mm. In continuation of his earlier measurements on wave-lengths in the near infra-red, Rubens and his co-workers examined the dispersion and absorption of the whole range of the infra-red in numerous substances. By making use of the refractive indices of numerous substances found for these long wave-lengths, or the values extrapolated for infinite wave-length, he tested the validity of Maxwell's law ( $n^2 = k$ ) between the refractive index for these waves, and the corresponding dielectric constant of the substance in question. Several series of measurements on the absorption of infra-red waves

in water vapour supplied him with the material requisite for the comparison of Bjerrum's theory of rotation spectra with experiment, and for calculating the main moment of inertia of the water vapour molecule.

In addition to his fundamental work on residual rays, Rubens accomplished much in other branches of radiation. He carried out measurements in collaboration with Hagen at the *Physikalisch-Technische Reichsanstalt* on the reflecting power (R) of metals, which led to the empirical result that for metals the coefficient of penetration ( $P = 1 - R$ ) for very long waves can be represented by the relation  $P = 0.365 \sqrt{\sigma/\lambda}$ , where  $\sigma$  is the specific resistance of the metal, and  $\lambda$  the wave-length of the rays in terms of the unit 0.001 mm. This result is in agreement with deductions from the electromagnetic theory of light. His investigations on the validity of the law of radiation are of primary importance. Conjointly with Kurlbaum he carried out measurements on black body radiation of long wave-length, and this work was largely responsible for a revision of Planck's first radiation formula, and thus supplied one of the experimental bases of the quantum theory. Only last year, Rubens again applied his great experimental ability in an endeavour to test Planck's law of radiation in its final form. The results of this work led to the complete confirmation of the theory. They were communicated to a Congress of Physicists at Jena in the autumn of 1921, and Rubens was acclaimed by the congress in a manner seldom met with in scientific life.

Rubens, whose wife survives him, was in failing health for some years prior to his death. To those who knew him well, it seemed that the privations attendant upon war-time conditions were in a large measure responsible for hastening the end. In addition to his great powers and achievements, his active nature and kindly disposition bound him closely to his colleagues, who realise that in Rubens they have lost much more than a valued colleague. The loss to science will be appreciated by those of other countries who came in contact with him, for one could not meet Rubens without feeling the forcefulness of a striking personality. Until his death he maintained none but the friendliest of feelings towards his colleagues in England, and during the long years of the great war he took a human interest in the well-being of those of our scientific nationals whose lot it was to be detained in enemy territory. For these he did what he could. Science mourns his loss, and the record of his active life will occupy a prominent place in the annals of science.

R. W. L.

THE opportunity is most welcome to add my expression of deep regret for the loss of Prof. Rubens at an age when much might still have been expected from his scientific activity. I will remember the enjoyment of the hospitality of himself and his family in days now past, in the residence attached to the Physical Institute of the University of Berlin, where memories of Helmholtz were evoked at every turn. One can recall the simplicity of the apparatus used in his personal investigations, in keeping with the directness of his main results. In these respects he retained throughout his career the stamp of the school of his early master Kundt.

The existence of sharply defined ranges of intense

optical reflection, even of the metallic type, from some crystals had been known and understood in its main features for a long time.<sup>1</sup> It was left for Rubens to develop it into what amounted to a new kind of spectrum analysis for invisible rays far down in the infra-red, by sifting the radiation by successive reflections. By this means he discovered and isolated precise narrow bands of dark radiation (*Reststrahlen*) very remote from the visible spectrum: just what was most needed at that time for the wider verification and consolidation of ideas regarding the general laws of radiation. In collaboration with Rubens in these investigations his friend E. F. Nichols first made his mark, soon to be followed up at home in America.

In later years by use of the *Reststrahlen* he was able to discover that in metals the defect from perfect reflection, for radiation of great wave-length, depended on their conductances alone. This was readily intelligible in a general way: for the square of the complex index of refraction for rays of frequency  $p/2\pi$  is of the form  $K - 4\pi c^2 p^{-2} \sigma$ , and as both terms of it are found to be effective in metals for ordinary light, the second term, involving  $p^{-2}$  and the specific conductance  $\sigma$ , must predominate far in the infra-red. But the entirely unexpected feature was that the agreement was so close that optical observations by themselves could give a good value for the ordinary conductance  $\sigma$  of a metal for continuous currents. In other words, the response to electric force in metals is so prompt that the mechanism of conductance becomes completely established within the fraction  $10^{-13}$  of a second of time, thus giving an essential datum for the understanding of the process of transfer of electrons in metallic bodies.

The decisive completeness of this incidental verification of the Maxwellian scheme of radiation naturally attracted general attention, in its contrast with the long years that elapsed in the early time before the cause of the imperfect correspondence of the refractive index with  $\sqrt{K}$  for transparent media was fully appreciated.

One was struck with the ease and simplicity of Rubens' modes of thought. The problems which he wished to attack came naturally to him, without any incrustation of theoretical complexities. Like Faraday and many another experimenter, he was an example of how far simple physical intuition could lead. The directness and cordiality of his personal qualities must have won and retained the regard of all who knew him.

JOSEPH LARMOR.

#### LIEUT.-COL. G. L. TUPMAN.

LIEUT.-COL. GEORGE L. TUPMAN, who died at Harrow on November 4 at an advanced age, was for many years a devoted amateur astronomer. He was elected a Fellow of the Royal Astronomical Society in 1863, being one of the oldest Fellows at the time of his death. He was on its council from 1873 to 1880, and secretary from 1884 to 1889. His earliest astronomical work was on meteor radiants: he made numerous observations of meteors while on service in the Mediterranean, 1869-1871, and published a catalogue of radiants in *Mon. Not. R.A.S.*, vol. 33. Tupman observed the transits of Venus in 1874 and 1882 from Honolulu and New Zealand respectively. He worked for some time

<sup>1</sup> Cf. *ex. gr.* Stokes in discourses at the Royal Institution and to the Chemical Society, as early as 1864: "Math. and Phys. Papers," vol. iv. pp. 244, 261.

at Greenwich Observatory as a volunteer, both in preparation for the transits and in their subsequent discussion; his preliminary result from a discussion of the 1874 transit,  $8^{\circ}.813$ , is very near the value now accepted. Since many of the stations were dependent on lunar observations for longitude, he studied carefully the errors of the lunar ephemeris from the results of all the leading observatories.

Tupman had a well-equipped observatory at Harrow, with two equatorials, reflector and refractor, and a transit circle. He made many meridian observations of stars, also occultations (especially during the lunar eclipses of 1884, 1888, 1895 for the determination of the moon's diameter), comets, transit of Mercury, etc.; he also frequently invited other astronomers to use his instruments.

A. C. D. CROMMELIN.

#### H. J. POWELL.

By the death of Harry J. Powell, on November 26, at the age of sixty-nine years, the country has lost one of the earliest pioneers in the scientific manufacture of glass. For some years he lived in the works at Whitefriars, and during this time, and for many years afterwards, he superintended personally the weighing out and mixing of the material for the next week's batch of glass. For forty-five years he was making experiments with the object of improving the quality of the flint glass made at Whitefriars, and attaining perfection of colour in the glasses. These have led to the magnificent results seen in the windows of the cathedrals of Salisbury, Liverpool, and New York, and in those of many churches in this country and abroad. He not only improved the nature and colour of the glass, but he was a designer of the first rank. Few of the art museums of this country are without specimens of his artistic skill.

Mr. Powell was well known to most scientific men, and was always ready to put his knowledge and technical skill at their disposal. The vacuum flask, the idea of which was conceived by Sir James Dewar, was made first by him, and it was to his experiments that the success of Sir William Crookes's cerium glass, for cutting off the ultra-violet and heat rays, was mainly due. At the outbreak of war, foreseeing the shortage of glass for chemical purposes, he worked out, in conjunction with his son-in-law, a soda-lime glass with very great resistance to changes of temperature and action of water. This glass was used by the Admiralty for the construction of the horns of submarine mines.

Mr. Powell retired from the business three years ago, and devoted his time to an attempt to make generally known the results of his knowledge and experience. He worked up to the last, the final revision of a book, "Glass-making in England," and of an article for Sir Richard Glazebrook's "Dictionary of Applied Physics," in which he propounded a new theory of the origin of colour in glass, being completed only a few days before his death.

By the death of Dr. Herbert Langton on October 12, in his seventieth year, the Museums Association loses its honorary treasurer, the museum sub-committee of Brighton its chairman, and the British Ornithological Union a valued member. A portrait appears in the *Museums Journal* for November.

## Current Topics and Events.

THE dyeing of artificial silk at one time presented many difficulties, which have, however, been overcome so far as the silk made by the Chardonnet and Viscose processes is concerned. On the other hand, the new "acetate silk" does not lend itself with equal readiness to the dyeing operation and, hitherto, some difficulty has been experienced in producing an adequate range of fast and pleasing colours. The "acetate silk" arose as an outcome of the war, when the general opinion was reached that the method of the Greifus Brothers for producing aeroplane dope from acetyl cellulose was the best. The large factories which were then built for the preparation of this substance had, when the war ceased, to turn their energies for the most part into other directions, and the manufacture of artificial silk was one of these. The silk is of great lustre and beauty, but as the composition of the acetyl cellulose remains unaltered even in fibre form, it does not possess any marked affinity for that large and important class of colouring matters which are substantive to cotton. This affinity can, however, be imparted to the fibre if conditions are present which cause it to undergo hydrolysis in the dye-bath, and Prof. A. G. Green, working in the Research Laboratories of British Dyes Ltd., has now succeeded in isolating a new and curious series of colouring matters which are apparently particularly suited for the purpose of dyeing acetate silk. These colouring matters belong to a class of compound which is readily hydrolysed in solution, and in that form can be fixed on the acetate silk. Moreover, the "Ionamines," as Prof. Green has named the new colours, can be made to possess a diazotisable amino group, and many beautiful shades can be obtained by diazotisation and development on the fibre. It follows also that, since the ionamines possess no affinity for the cotton fibre, it is possible to dye a fabric composed, for example, of cotton and acetate silk, two colours in one bath. Thus, in a bath containing a mixture of chlorazol green BN (a substantive cotton dye) and ionamine KA, the cotton will be dyed green and the acetate silk red. The effects, which are very striking, should go far to render the new silk popular.

AN International Aeronautical Exhibition will be held at the Grand Palais, Paris, during the second half of this month, commencing on December 15. As is to be expected in view of the great interest aroused by the remarkable records set up during the past few months, particular attention will be devoted to motorless or wind flight. Gliders that were used in the recent contests will be exhibited, including the machine in which Maneyrol so dramatically beat the German duration record, just at the end of the gliding week on the South Downs. A particularly interesting feature of the exhibition will be the attempt to illustrate the scientific principles underlying wind-flight, both as regards the results already achieved and the problems that yet remain to be solved. Thus, in addition to showing the wings

of such birds as the albatross, eagle, condor, etc., the promoters will illustrate the way in which the presence of wind renders motorless flight possible. Such winds are (1) vertical convection currents in the air due to the sun's heat; (2) upward currents due to the existence of undulations in the ground, like hills and valleys, the main feature of the flights executed during the past few months; and (3) varying horizontal currents, which are known to aid motorless flight. Some use of the latter appears to have been made in a recent flight in Germany.

A FILM record of the Mount Everest Expedition of 1922 was shown for the first time at a joint meeting of the Royal Geographical Society and the Alpine Club held on Tuesday, November 21, at the Central Hall, Westminster. The film, which is one of exceptional interest and permanent value as a record of life in Tibet and the conditions of mountain exploration in 1922, is the work of Capt. J. B. L. Noel, who succeeded in operating his cinematograph at an altitude higher by many thousands of feet than any to which such an instrument has previously been carried. He made sure of good results by developing his films, under great difficulties, partly in a tent by the Rongbuk glacier torrent at a height of 16,500 feet, and partly in a dark room he built in the old fort at Gyantse. The conditions were such that when the film was wet it froze; when dry it sparked with the slightest friction and could not be kept free from dust. In spite of these difficulties, however, a good film-record was obtained. The subjects of the film include the scenery of the forest belt beyond Darjeeling; the bare and dry plateau of Tibet; the mode of life of the Tibetans; the Rongbuk monastery with its sacred Lama and ritual dances; the approach to Mount Everest along the Rongbuk glacier; and the assault on the mountain by the climbing parties, by way of the North Col. The effects of the terrible wind, flinging clouds over the North Col and tearing the snow from the mountain, were well shown on the film. Capt. Noel took his cinematograph to Camp III. (21,500 feet), and, using a telephoto lens, photographed the descent of the first climbing party, who had discarded oxygen and reached a height of nearly 27,000 feet. He ascended to Camp IV. (22,500 feet) on the North Col with the second party, who carried oxygen, and photographed them next day during the first 2000 feet of their ascent to 27,235 feet, the highest point reached. The Mount Everest Committee has arranged for the film to be shown to the public for a season at the Philharmonic Hall, as well as in the principal cities of Great Britain. The proceeds will be devoted to the cost of a third expedition.

In his interesting and suggestive presidential address to the Surveyors' Institution on November 13 Mr. J. McClare Clark discusses the effect of post-war conditions on agriculture and shows that the sequence of events since 1918 is exactly parallel to that after 1818, and that in many respects events of 1922 closely resemble those of 1822. During the

Napoleonic wars the prices of wheat rose enormously; in 1800 it was 113s. 10d. per Imperial quarter. Under this stimulus farmers made great efforts to increase production, and in spite of depleted supplies of labour they kept the country provided with food. Soon after the peace, however, there set in a severe break in prices due to the general financial dislocation. Unemployment was rife in all parts of the country and Poor Law methods added to, rather than mitigated, the difficulties. To make the resemblance between 1822 and 1922 even closer, there was a remarkable similarity in the seasons. The history of the years following 1822 affords hope for the future. Agriculture improved with the gradual readjustment in the financial and commercial position, while the introduction of railways proved of enormous benefit. From 1836 onwards progress was unmistakable, while the founding of Rothamsted in 1843 and of the Royal Agricultural College, Cirencester, in 1845 marked the introduction of scientific methods which completely revolutionised British agriculture and opened up an era of prosperity that closed only when the new countries of the West flooded our markets with produce at prices with which the British farmer could not compete. It is a hopeful augury for the future that the scientific organisation is already well developed. Colleges and new research stations have been opened, Rothamsted has been reorganised and greatly extended during the last few years, while Cirencester was reopened a few weeks ago.

It is difficult for any one who has received a scientific training to believe that anything can be said in favour of our cumbersome and complicated system of weights and measures, or to understand the difficulties which are advanced against the adoption of the metric system, which has become the international language of quantity. In his presidential address to the Decimal Association on November 23, Sir Richard Gregory pointed out that in forty-six countries of the world the system is now obligatory, the latest addition being Japan, which adopted metric measures in April last. The United States and the British Empire are the only two civilised nations which remain outside this circle, and they must come within it eventually, as there is no possibility of the Imperial system being adopted internationally. With every development of electrical science metric measures come into increasing use; for all the units employed are based upon the metric system. In wireless communication, and for broadcasting, wave-lengths are expressed in metres, and in aviation international regulations are similarly described. Even among English-speaking peoples there is much diversity in the weights and measures employed. The standard gallon in the United States is the old wine gallon of 231 cubic inches instead of the Imperial gallon of 277·274 cubic inches; the hundredweight there and in Canada is the cental of 100 lb. instead of the Imperial cwt. of 112 lb.; and the ton is the short ton of 20 centals or 2000 lb. instead of the ton of 2240 lb. The simplest way to avoid the confusion consequent upon these and other

diversities would be to adopt the metric system, and the Decimal Association and American Metric Association working for this end may be assured that their efforts must finally achieve success.

In order to demonstrate some of the minor uses of home-grown timber a special exhibit is on view in Museum iv, in the Royal Botanic Gardens, Kew, of requisites commonly used in kitchen, laundry, and dairy. Among them are bread boards, rolling-pins, towel rollers, measures, scoops, bowls for milk and pastry, butter knives and pats, butter prints, dishes for skimming milk, potato mashers, steak beaters, brushes and brush backs, spoons, mangle rollers, a washing dolly, egg-cups, a plant-tub, and some wood wool. The last-named is a most useful substance for packing fruit, glass, and crockery. The principal woods used for these articles are beech, lime, sycamore, birch, elm, poplar, and willow. A number of articles are shown in various stages of manufacture, thereby demonstrating the immense amount of work that is required to produce a common utensil that may be purchased for a few pence, and at the same time indicating what an important part is played by the manufacture of home-grown timber, even into minor articles, in the provision of employment for large numbers of men and women.

SOME interesting figures are given in the issue of the *Engineer* for November 17, which show the relative costs of transport by different agencies working at their normal speeds. The list opens with the barge, with a speed of 1 mile per hour at an estimated cost of 0·0004l. or 1<sup>1</sup>/<sub>2</sub>d. per ton-mile, and at the other extreme is the maximum expenditure per ton-mile of the R.A.F. in England, with the cost for a speed of 100 miles per hour of 9·3l. or 2232d. Between these extremes are some surprising results, some of which are based on official figures while others are estimates. The London motor omnibus at 10 miles per hour costs 0·016l. or 4d. per ton-mile. An electric passenger train (3rd class) at 25 miles per hour costs 0·018l. or 4d. per ton-mile, while the corresponding steam train at 40 miles per hour costs 0·024l. or 6d. With these figures can be considered the cost per ton-mile at 12 miles per hour of a liner (1st class), which is 0·22l. or 53d., though for the liner (3rd class), it is only 0·1l. or 24d. The London-Paris passenger aeroplane service, assumed to travel at 100 miles per hour, at present rates costs 0·33l. or 80d. per ton-mile, though the estimate of the Advisory Board for Civil Aviation is 0·7l. or 168d. The cost of running a Rolls-Royce car, assuming a speed of 22 miles per hour, is estimated, at the maximum, to be 1·0l. or 240d. per ton-mile. Turning now to carrying services, it is interesting to find that parcel post, for a speed of 12 miles per hour, costs 0·07l. or 17d. per ton-mile, while letters, at 17 miles per hour, cost 0·55l. or 132d. per ton-mile, and the postman himself, travelling at 3 miles per hour, is estimated to cost 4·85l. or 1164d. per ton-mile. Estimates for the rigid airship vary from 0·016l. or 4d. per ton-mile at 80 miles per hour to 1·8l. or 432d. per ton-mile at 40 miles per hour, the latter figures referring to a machine assumed to carry a load of 10 tons.

THE issue of *Science* for November 3 contains a paper by Dr. J. R. Schramm of the National Research Council on "The Abstracting and Indexing of Biological Literature," which is of interest as it shows that in the United States the subject of the organisation of bibliography is entering the field of practical politics. Dr. Schramm's paper is eminently business-like. He first investigates the wants of the research student and decides in favour of sufficient abstracts published in book-form, with adequate indexes—"the complete subject index being perhaps of the greater importance." He then turns to the publishing aspect and points out that with adequate support in the shape of a guaranteed circulation, the cost of composition is a relatively small matter—each copy costing little more than the cost of paper, machining, binding, and distribution. From these data he goes on to advocate publication on the lines of *Chemical Abstracts*. The federation of the Biological Research Associations of the United States is, of course, a necessary preliminary, but here the first steps have already been taken under the ægis of the National Research Council. A committee has been formed to draft a constitution and to report on the whole question. Dr. Schramm does not underrate the difficulties before him, but we think that he underestimates the volume of literature with which the federated body will have to deal. If the statistics of the International Catalogue of Scientific Literature afford any guide, the federation will have to deal with an output at least double that of pure and applied chemistry. The order for the output of the International Catalogue for 1901-13 was (1) physiology, (2) zoology, (3) chemistry, (4) botany, (5) bacteriology. It is, however, premature to discuss a scheme which has not yet been definitely forwarded. We shall be content to express a hope that we may be favoured with a copy of any further report of the committee's activities.

THE Iron and Steel Institute, 28 Victoria Street, S.W.1, is prepared to receive before the end of February next, upon a special form obtainable from the secretary, applications for grants from the Andrew Carnegie Research Fund in aid of research work on the metallurgy of iron and steel.

CAPT. H. RIALI SANKEY will deliver his presidential address to the Junior Institution of Engineers on Tuesday, December 12, at 7.30, taking as his subject "The Utility of Theory to the Practical Man." The address will be given at the Royal United Service Institution, Whitehall.

A COURSE of twelve free public Swiney lectures on "Fossils and what they teach" will be given in the lecture theatre of the Imperial College of Science and Technology, South Kensington, by Prof. T. J. Jehu at 5.30 on Tuesdays, Thursdays, and Fridays, beginning on Tuesday, December 12.

THE gold medal of the Ramsay Memorial Fund, which the Prince of Wales would have received after unveiling the memorial in Westminster Abbey if he had been able to be present, was presented to him

on November 22 by the French Ambassador, the Comte de Saint-Aulaire, who was accompanied by the officers of the memorial fund.

IN connexion with the Institute of Industrial Administration a lecture on "Standardisation of Repairs in Relation to Industrial Economy" will be delivered at the London School of Economics, Houghton Street, Aldwych, on Tuesday, December 12, at 8 o'clock, by Mr. R. Twelvetrees. The meeting will be open to all, and the lecture will be followed by a discussion.

THE council of the Institution of Electrical Engineers of London at the last meeting announced that Dr. J. A. Fleming had been elected an honorary member of the Institution. Dr. Fleming has accepted the invitation to give the fourteenth Kelvin lecture to the Institution in May next. The Royal Society of Arts recently awarded Dr. Fleming a silver medal for the fifth Henry Trueman Wood lecture he delivered on November 23, 1921, "On the Coming of Age of Long-Distance Wireless Telegraphy and some of its Scientific Problems."

THE Committee of the Norfolk Agricultural Station, Norwich, will shortly appoint a director and solicit applications for the post, which will be of the annual value of 600*l.*, plus travelling and incidental expenses. In the first instance the appointment will be for one year only. Applicants must possess a modern scientific training in agriculture, with university degree or diploma, practical knowledge of mixed farming, organising ability, and be qualified to lecture. Applications, with testimonials, must reach the honorary secretary of the committee, 32 Prince of Wales Road, Norwich, by, at latest, Saturday, December 9.

THE first country meeting of the Association of Economic Biologists since pre-war days will be held in the Botanical Department of the University of Manchester on Friday, December 15, when Dr. W. Lawrence Balls will open a discussion on "Genetics in Relation to Applied Biology." Dr. S. G. Paine will read a paper on "Internal Rust Spot (Sprain and Net Necrosis) in the Potato and the Possible Association of this Disease with Leaf Roll," followed by informal discussions on "The Place of Applied Biology in Universities," and "The Relation of Biology to Medicine." On Saturday, December 16, a visit will be paid to the British Cotton Industry Research Association, Shirley Institute, Didsbury.

THE suggestion made by Mr. F. Gill, president of the Institution of Electrical Engineers, in his recent address, that an international European conference should be held with the view of establishing on a commercial basis a practical system of long-distance telephony in the European trunk lines, has now been realised by M. Paul Laffont, the French Minister of Telegraphs and Telephones. He proposes to invite a conference at Paris of the technical administrators of the Western European countries, and he urges that France would naturally be the centre of the vast telephone system formed by combining the systems of these countries. The long-distance

telephone calls in daily use in America show that, from an engineering point of view, the scheme presents few difficulties. Thus the New York-San Francisco call (3000 miles) is equivalent to communication between London and Baghdad; the Key West (Florida) and Los Angeles call *via* New York and San Francisco is equivalent to a London-Delhi communication. English engineers all welcome the conference, as they have good hopes of arriving at a satisfactory international agreement.

THE *Quarterly Summary* of the Royal Botanic Society, Regent's Park, for October contains a list of some of the recent interesting accessions to the gardens, and a short account of the experimental work in genetics being carried out there. Another item of interest is an account of the Indian Mahwa tree, *Bassia latifolia*, a member of the Sapotaceæ, the flowers of which have the remarkable property of showing no deterioration even after being stored for a year or two in England, nor are they attacked by moulds. They contain quantities of sugar and have been suggested as a source of alcohol, but their peculiar preservative powers have apparently not been investigated.

A NOTEWORTHY departure was taken at the meeting of the Royal Institute of British Architects on November 20, when a paper on "Illuminating Engineering in Relation to the Architect" was read by Mr. L. M. Tye. A vote of thanks to the lecturer was proposed by Sir John Herbert Parsons, president of the Illuminating Engineering Society, who referred to the good results that had followed from the co-operation of the medical profession and the lighting expert in dealing with the effects of light on the eye, and expressed the conviction that similar benefit would be derived from the concerted efforts of architects and illuminating engineers. Mr. L. Gaster suggested that courses of instruction on artificial lighting should be included in the curriculum of architectural students, and Mr. Paul Waterhouse, who presided, received these suggestions with sympathy. There is no doubt that the lighting of many public buildings, schools, etc., would gain by closer co-operation of this description, and the Illuminating Engineering Society should do good public service by its efforts to enlist this new ally in its campaign for more scientific methods of lighting.

THE opening meeting of the session of the Illuminating Engineering Society took place on November 14, when Mr. L. Gaster read the usual report of progress during the vacation. An event of outstanding importance has been the third Report of the Home Office Departmental Committee on Lighting in Factories and Workshops. Mr. Gaster directed attention to an important "access of light and air" judgment in Bradford, which illustrated the importance now attached to scientific measurements of daylight illumination in such cases. It was mentioned that a commission on illuminating engineering has now been formed by the Central Electrotechnical Council in Russia. In accordance with custom, there were a series of exhibits illustrating develop-

ments in lighting. A new and simple illumination photometer was exhibited by Capt. Stroud, and an improved form of inspection lamp for use in hospitals by Mr. Hobson. Mr. S. O. Pearson demonstrated an interesting "blinking" phenomenon when neon lamps are shunted by a condenser on direct-current circuits, and Capt. W. J. Liberty presented some photographs showing the artificial lighting arrangements at the new Port of London building. Some novel forms of illuminated signs, based on total internal reflection in a sheet of plate glass, were exhibited by Mr. E. T. Ruthven Murray.

AT the Royal Academy, on November 22, Prof. A. P. Laurie, in a lecture on "The Preservation from Decay of Stone on Buildings," dealt with the general causes of stone decay. He showed by experiments the distinctions to be made between limestone, sandstone with a calcite cement, and sandstone with a silica cement, and described the different methods necessary to make complete laboratory tests with a suggested preservative, and illustrated by photographs some of the difficult problems which have to be faced. Prof. Laurie described a new preparation recently discovered by him, which deposits hydrated silica as a cement between the particles of the stone, and he stated that, while not solving the problem of the preservation of limestones, he hoped that it would prove successful in the preservation of sandstones. He further suggested that the Royal Institute of British Architects might find it worth while to experiment with this new preservative.

THE annual Progress Report of the Geological Survey of Western Australia for the year 1921 contains a useful summary of economic minerals known to exist in that State. Among these are, in the first place, gold, then copper ores, lead ores, tin ores, iron ores, and manganese ores, together with a number of rarer minerals such as wolfram, scheelite, stibnite, barytes, monazite, tantalite, glauconite, salt, gypsum, etc.; coal of different geological ages is known, although only permo-carboniferous coal has been worked to any extent.

SOME papers of much interest to marine biologists are contained in the recently issued number of the *Journal of the Marine Biological Association* (vol. xii. No. 4, October 1922). Mr. R. S. Clark gives descriptions, illustrated by beautiful photographs, of the egg capsules and young of various species of rays and skates. This work was badly wanted. Miss Lebour and Mr. Andrew Scott write on the food organisms of young edible fishes, and Miss Lebour and Mr. R. Elmhirst make a very useful contribution to parasitology in the form of an account of the life-history of *Parorchis acanthus*, a trematode inhabiting the herring gull.

IN further reference to the obituary notice of Dr. Alexander Graham Bell in *NATURE* of August 12, p. 225, Mr. F. De Land, of the Hubbard Memorial Hall, Washington, writes, giving us quotations from English papers of 1877, of telephone transmission over distances greater than 100 miles. He also gives a quotation from our own columns (November 15, 1877,

vol. 17, p. 49) of a report of a lecture by Graham Bell, stating that on one occasion the lecturer had been able to converse over a distance of about 250 miles. Our reference, however, in the obituary notice of Graham Bell, was to *commercial* telephony. In the Journal of the Institution of Electrical Engineers, April 1922, p. 429, Mr. Kingsbury gives the following quotation from the first business circular issued by Graham Bell and his associates. They state that they were "prepared to furnish telephones for the transmission of articulate speech through instruments not more than 20 miles apart."

PROF. H. E. ARMSTRONG asks us to say that in his letter published in NATURE of November 25, p. 700, he wrote Babelonian, which was altered without his approval to Babylonian—thus obliterating his point.

### Our Astronomical Column.

POSSIBLE RECURRENCE OF A METEOR SHOWER.—On the morning of December 5, 1921, there was observed a very rich shower of meteors from Leo Minor at  $156^{\circ} + 37^{\circ}$ . The event was witnessed at the Astronomical Observatory at Tokyo by the observers there, who recorded 44 meteors in 55 minutes, radiating from the special shower alluded to. The position in the N. part of Leo Minor from which the meteors were directed has been known for many years as the centre of a rich shower of swift, streaking meteors in October, November, and the first half of December. It was well observed at Bristol in 1876, November 20-28, from the point  $155^{\circ} + 36^{\circ}$  (21 meteors), and is especially described as a possibly new and very active shower in NATURE for December 21, 1876, p. 158. Should this meteoric display recur in the present year it may be looked for in England at about midnight and the two hours immediately following, on December 4. The moon will, however, be nearly full and will moderate the character of the display. It will certainly be important to observe it if possible, and it is hoped that the sky will be attentively watched on the date in question.

CALENDAR REFORM.—Mr. Charles F. Marion, of the U.S. Weather Bureau, has published a leaflet strongly urging the adoption of a 13-month calendar, each month to consist of 4 weeks exactly. One day in the year, preferably the last, would be outside week and month. In leap-year there would be another such day, which might conveniently precede the first day of the seventh month. The names "Sol" or "Mid-year" are suggested for the seventh month, the other months having their names unchanged. It is pointed out that meteorology would be greatly simplified by such a system, since records at present are complicated by the unequal months. Further, since each particular week would then always occupy the same place in the solar year, monthly records could be supplemented by weekly ones.

The chief objection brought against the 13-month year is that it does not divide into quarters. But it is to be noted that the existing quarter-days are not at the ends of months. To place them after the first week of the fourth month, the second of the seventh month, etc., would be very little more complicated than the present system. Monthly payments would be made 13 times per annum instead of 12, and the anomaly of paying the same for 28 days as for 31 would be removed.

Astronomers would welcome the equalisation of the months and the removal of leap-day from its present awkward position. The year 1928 begins with a

AMONG the books to be published by the Cambridge University Press during December is "Prolegomena to Analytical Geometry in Anisotropic Euclidean Space of three Dimensions," by E. H. Neville, the first half of which will be an account of the principles underlying the use of Cartesian axes and vector frames in ordinary space. The second half will describe ideal complex Euclidean space of three dimensions and develop a system of definitions in consequence of which the geometry of this space has the same vocabulary as elementary geometry, and enunciations and proofs of propositions in elementary geometry remain so far as possible significant and valid. The same publishers also promise for this month "A Summer in Greenland," by Prof. A. C. Seward. It will contain some 30 maps and illustrations.

Sunday, so the change might then be made with a minimum of dislocation.

A bill has been introduced into the United States Congress authorising and requesting the President to call an international conference on the subject in 1923. It is suggested that the dates of religious festivals are best left to the religious bodies to determine: it introduces needless difficulties to superpose these questions upon changes in the civil calendar.

THE BRIGHTNESS AND ROTATION OF URANUS.—*Astr. Nachr.* No. 5184 contains a paper on this subject by C. Wirtz. He has made a very careful series of magnitude determinations with a Zeiss field-glass from July 1921 to January 1922. The mean magnitude, reduced to mean opposition, is 5.64. The magnitudes of the six comparison stars were taken from Harvard; small corrections, leaving the mean magnitude unchanged, were deduced from his own observations. The author is evidently a skilled observer and the probable error of each night comes out as 0.04<sup>m</sup>, that of the mean being less than 0.01<sup>m</sup>. He has grouped them in accordance with the rotation period of 10½ hours given by the spectroscope, and finds a sine-curve with an amplitude of 0.02<sup>m</sup>, which he regards as too small to receive with confidence; in 1917, L. Campbell found a curve with an amplitude of 0.15<sup>m</sup>, but if the physical state of Uranus is like that of Jupiter, changing spots might well alter the amplitude.

Wirtz suggests that it is worth while to keep up the investigation of the magnitude of Uranus from year to year, as it may throw light on the oblateness of the disc. He estimates that when the pole is near the centre, the magnitude should be about 0.1<sup>m</sup> brighter than when it is on the edge; this is an amount within the reach of delicate photometry. He thinks, however, that the apsidal motion of the inner satellite Ariel should give a more trustworthy value.

MISCONCEPTIONS ABOUT RELATIVITY.—Since the verification of the Einstein bending of light by gravitation in 1919, many speculations on the subject have appeared in astronomical publications. A letter in the Journal of the R.A.S. of Canada (September-October 1922) suggests that the Gegendeschein is the result of the bending of sunlight by the earth's attraction so as to come to a focus. The amount of bending of a grazing ray is proportional to mass/radius, so that the bending at the earth's surface is  $1''.75/3000$  or  $1/1900$  of a second of arc. It is manifest that such an infinitesimal bending could produce no discernible optical effects, and it seems inadvisable to print such suggestions without comment, since their appearance in such a weighty journal is calculated to mislead.

## Research Items.

**SOME ROMAN ANTIQUITIES.**—Two articles in the *Journal of Roman Studies* (Part 1, vol. 10 for 1920) refer to antiquities in England. In the first, Mr. A. M. Woodward describes a decorative bronze Silenus mask found at Ilkley during excavations conducted by the Yorkshire Archaeological Society. This was probably used as a jug-handle, and that a bronze vessel so elaborate should be found at the quarters of an auxiliary cohort is at first surprising. But the site seems to have been long occupied, and the inhabitants included a civilian settlement. The vicinity of York, a great military station, may have led to the introduction of articles of luxury. In the second paper Mr. C. D. Chambers remarks that, although the Romans valued pigeon manure, it is strange that so few dovecots of that period have been discovered. Though octagonal foundations like those of medieval dovecots have been found at Great Witcombe and Stroud, rectangular dovecots, though probably numerous, cannot be identified with certainty, except where the pigeon-holes actually exist, as at Caerwent. If excavators were to look for dovecots rather than shrines, it is not unlikely that further evidence would be forthcoming.

**THE PITUITARY BODY.**—A paper by Bailey and Bremer ("Experimental Diabetes Insuperidus," "Archives of Internal Medicine," vol. 28, p. 773) serves as a timely warning against hasty conclusions of the existence of internal secretions when the results have been brought about by injury or disease supposed to be limited to a particular organ. There are three symptoms supposed to be produced by injury of the pituitary body—increased urinary secretion, hypertrophy of fatty tissue, and atrophy of the testis. Camus and Roussy had already brought evidence that these effects were due to injury of that part of the brain, the hypothalamic region, in close contact with the pituitary body, but they do not appear to have been altogether successful in avoiding some injury to the latter also. The work of Bailey and Bremer was done in the laboratory of Prof. Harvey Cushing, and the pituitary region was reached by a slight modification of the operation described by Crowe, Cushing, and Homans. The pituitary body itself and the neighbouring parts of the brain can be clearly seen, and it was found that a small injury to the hypothalamus, leaving the pituitary completely intact, was sufficient to bring about the three symptoms above mentioned, which are supposed to be due to injury to the pituitary body itself.

**STERILITY IN SPECIES-CROSSES.**—Results have been accumulating for a number of years, showing that in species-crosses in various animals one sex is either absent, rare, or sterile. Such disturbances of the sex-ratio, or sterility of one sex in the hybrids, have been observed by Tutt, Harrison, Goldschmidt, and others in Lepidoptera, by Whitman, Riddle, and others in birds, by Sturtevant in *Drosophila*. Among mammals, guinea-pigs and Bovidae show similar distortions of the sex-ratios. Mr. J. B. S. Haldane, in an interesting review of all these and similar results (*Journ. of Genetics*, vol. 12, No. 2), shows that in every case it is the heterozygous sex which is deficient in numbers or sterile in such species-crosses. Thus in mammals and flies this applies to the male sex, which is the heterozygous sex, while in birds and butterflies it applies to the female sex, which is known from breeding experiments and cytological study to be the heterozygous sex in these groups.

**CHROMOSOMES OF THE "MILLIONS" FISH.**—In two papers on the cytology and genetics of the little

"millions" fish, Lebistes, Dr. Ö. Winge (*Journ. of Genetics*, vol. 12, No. 2) finds the number of chromosomes to be 46 in both sexes, and concludes that the males must therefore have an XY pair of sex-chromosomes. In extending the breeding experiments of Dr. J. Schmidt, who showed that certain colour markings of the males are inherited only from male to male (hence through the Y-chromosome), he finds four such colour-marking factors in the Y-chromosome of different races of this fish. In addition, Dr. Winge makes the interesting discovery that in the "Magdeburg race" the X-chromosome contains a factor which gives a sulphur-yellow colour to various parts of the body and a red colour to the lower margin of the caudal fin. This factor is inherited in the usual fashion of sex-linked factors, except that all these characters are invisible in the females. Some evidence is also obtained of crossing-over between these factors in the X- and Y-chromosomes. This, if confirmed, will furnish an interesting extension of our knowledge of sex-linked inheritance. When colour-marking factors are present in the X- and Y-chromosomes of a male they both show in its visible pattern, but one is transmitted, like the X-chromosome, through the daughters to their sons, while the other is transmitted (in the Y-chromosome) directly from father to son.

**COTTON RESEARCH IN EGYPT.**—The second annual report, for 1921, of the Cotton Research Board, issued by the Egyptian Ministry of Agriculture, indicates clearly that the improvement of the cotton crop, with which the prosperity of Egypt is so closely connected, is being seriously dealt with by methods of research. The Board has given special consideration, among other matters, to the decline in yield, two-year *v.* three-year rotations, and control of seed used for sowing. A summer fallow appears to be of great value in maintaining the fertility of the soil, as the temperature of the surface soil rises sufficiently high to have a partial sterilisation effect by suppressing the harmful factor which has been shown to exist in Egyptian soils. The value of Nile silt as a fertiliser seems hitherto to have been exaggerated. Yield may not be much affected by reduced watering, but quality may be adversely influenced. Work is being done on the extraction of pure lines, propagation of selected strains and field tests of commercial varieties, in order that types may be selected that shall be most suitable for the purpose required. Special efforts have been made to find a method of controlling the sore-shin disease, the usual means being ineffective or impossible of application on a large scale. Various reagents have been used for soaking the seeds, and the effect of sowing on different dates has been tested, but no conclusive results are yet available. Insect pests are also receiving attention, pink boll-worm and cotton-seed bug being under investigation.

**THE CRANIAL MORPHOLOGY OF FISHES.**—Two important papers on the anatomy and morphology of fishes appear in the *Journal of Anatomy* (vol. 56, Pts. 3 and 4). In the first of these Mr. E. Phelps Allis, junior, describes in great detail the cranial anatomy of *Polypterus*, illustrated by twenty-two beautifully executed plates, all except two of which are in colour. In the second paper Dr. H. Leighton Kesteven strongly criticises Huxley's interpretation of the bones in the palate and upper jaw of bony fishes and offers a new concept of their significance and homologies. He regards the premaxillæ and maxillæ of the majority of teleostean fishes as constituting



an adventitious jaw which is homologous, not with the similarly named bones in other vertebrates, but with the labial cartilages well developed in most Elasmobranchs, present in *Polypterus* and evanescent in the Amphibia. The vomer, anterior portion of the parasphenoid and palatine of the teleostean skull are regarded as homologous respectively with the premaxilla, vomer, and maxilla of other vertebrates. This new interpretation of the upper jaw of the teleostean fishes necessitates changes in the concept of the homologies of other bones in the palate of these fishes, which the author states briefly and analyses in detail. The quadrate bone of teleosteans is the only bone which the author regards as correctly homologised.

**JAPANESE GEOLOGY.**—The National Research Council of Japan has instituted a *Japanese Journal of Geology and Geography*, of which the second number lies before us. In addition to various abstracts it contains two original papers. The first, by Prof. I. Hayasaka, treats of "Some Permian Brachiopods from the Kitakami Mountains." Only six species are described, none being new to science, but there is a promise of more when the additional material shall have been worked out. The second paper is on "Uhlagina, a New Type of Foraminifera found in the Eocene of Japan and West Galicia," by Prof. H. Yabe and S. Hanzawa. The authors consider this new form to be a close ally of the Carpathian species *Rupertia incrassata*, Uhlig, and since both differ in important characters from *Rupertia*, the new genus *Uhlagina*, having as genotype *U. boninensis*, n.sp., from the Middle Eocene nummulitic tuff of Oki-mura, is established for their reception.

**WIND VELOCITY AND DIURNAL RANGE OF TEMPERATURE.**—A discussion on diurnal variation of temperature as affected by wind velocity and cloudiness, Professional Notes, No. 30, has just been issued by the Meteorological Office of the Air Ministry. The observations from the Eiffel Tower have been used in conjunction with those at Parc St. Maur by Captain J. Durward. The object of the discussion is to get an idea of the magnitude of the rise and fall of temperature at different levels under different weather conditions. Observations are compared for the five months, May to September, and for the five years, 1905 to 1909. The respective heights above sea-level of the thermometers at the two stations are 335 metres and 50 metres, a difference of 285 metres or 935 feet. The lower station, Parc St. Maur, is 11.5 km. to the east-south-east of the centre of Paris. Among the principal results may be mentioned the temperature distribution on fair nights. When the radiation is unimpeded the layer of air in contact with the ground is cooled more quickly than the layers immediately above, and being cooled it tends to remain near the earth's surface. This leads to an inversion in the lower layers of the atmosphere, the magnitude depending on the wind velocity, as the layers not in immediate contact with the ground are cooled greatly by turbulence; the results are given in a table.

**OIL-DRILLING IN GALICIA.**—Mr. Albert Miller's recent paper read before the Institute of Petroleum Technologists dealt with the Canadian pole-tool system of drilling for oil, as almost exclusively employed in Galicia at the present time. Notwithstanding the increasing popularity of the rotary system in other oil-fields, this system has proved unsatisfactory in Galicia, where the formations to be penetrated frequently change with surprising rapidity within a small vertical distance; this

necessitates a high degree of flexibility of drilling plant. The paper included details of the tackle in use, and the different types of drilling-bits and fishing-tools were discussed, particular stress being laid on the need for standardisation of tool joints, the lack of which had proved almost disastrous in the past. Some useful information was given in connexion with casing and with its recovery when "frozen" in a well; a somewhat novel method of overcoming such freezing is to insert tubing connected to the steam-line and thus heat the casing for twenty-four hours; by this expansion, with subsequent contraction on cooling, the casing can often be moved; this method is also applicable in cases where accumulations of paraffin wax are the cause of such freezing. Methods of production of oil in Galicia were also considered, and these included, besides flowing wells, both deep-well pumps and "swabbing." This last practice is specially useful in wells that have stopped flowing, and in deep wells having small diameter casings but producing from compact sandstone. The swab consists of a plunger fitted with a ball-valve which works up and down inside the casing barrel; rubber packing rings are employed, and thus the swab has a suction effect on the well; an average vacuum of eight pounds can be obtained with fast running on the upward journey of the swab, and in this way several tons of oil may be won which would otherwise be left in the reservoir.

**ASPHALT.**—The report on the asphalt and related bitumen industries in the United States for the year 1921 has just come to hand (*Asphalt and Related Bitumens in 1921*, United States Geol. Sur., Mineral Resources, Pt. II.). In that year the United States marketed close on 300,000 short tons of natural asphalt (including grahamite, gilsonite, wurtzilite, imponite, and bitumenous rock). By far the larger quantity of asphaltic material, however, is manufactured from crude petroleum during the process of refining the oil, the basis of this material being the residue resulting from distillation. The material is of two distinct kinds, asphalt and flux, the former comprising all the solid and semi-solid products of less than 200 penetration. The flux is utilised for softening natural asphalt or the synthetic product, especially for roofing purposes; it also includes the so-called "road-oil" used for spraying on the surface of metalled roads. For paving it is produced as sheet asphalt, or as asphalt concrete, or as a cement or filling for road and pavement blocks; the roofing and water-proofing material is manufactured by saturating, coating, or cementing felt or suitable fabric; in the rubber industry it is employed in many cases where a durable binding or cement is required. In other directions asphalt finds considerable use in the manufacture of insulating materials, acid-resisting compounds, mastic, paint, and varnish. In the United States, both domestic and Mexican petroleum are used as sources of the manufactured asphalt, the latter rather more than the former; in 1921 more than 600,000 tons of asphaltic material were produced from domestic petroleum, this representing about two-thirds of the amount obtained from imported oil from Mexico. The report also makes brief mention of the importation of natural mineral waxes, such as ozokerite, into the United States (which during the year under review increased more than 100 per cent.), while the manufacture of ichthyol compounds from a Texas oil is a noteworthy development. Ichthyol (a sulphonated hydrocarbon largely used in medicine) has in the past been produced from treatment of a fossiliferous deposit in the Austrian Tyrol; its manufacture from natural petroleum constitutes a factor of more than mere commercial interest.

## The Society of German Men of Science and Physicians.

CENTENARY CELEBRATIONS AT LEIPZIG.

IT is a hundred years since the Society of German Men of Science and Physicians held the first meeting, also in Leipzig, on September 18, 1822. Only eighty-seven meetings have taken place in this period, as in the years of great national calamities, such as war or epidemics, no meetings were held. Though the first meeting after the World-War, at Munich in 1920, was well attended, the society resolved to meet only every two years, so long as the present economic distress in Germany prevails.

Among the scientific workers who attended this year's meeting there were represented not only the great seats of learning of Germany and the German-speaking countries, but also most of the countries who had in former times sent their representatives to this meeting. The president was the distinguished Berlin physicist, Prof. Max Planck, Nobel prizeman in 1918 for physics. The committee included, among others, Prof. Paltauf, the great Vienna pathologist; von Dyck, the Munich mathematician; Profs. Gottlieb (Heidelberg), Willstätter (Munich), His and Bonhöffer (Berlin), Rinne (Leipzig); Privy Councillor Duisberg (Leverkusen). The arrangements for the meeting were carried out under the supervision of Prof. von Struempell and Prof. Wiener, both of Leipzig.

After the opening address by Prof. von Struempell, on September 18, in which he expressed his satisfaction at the great new tribute paid to German science, addresses were given by representatives of educational authorities, teaching institutions, and learned societies. Among the foreign representatives were: Prof. Becke (Vienna), Prof. Schlosser (Prague), Prof. Hagenbach (Basel), Prof. Sigrist (Bonn), Dr. Sven Hedin and Prof. Svante Arrhenius (Sweden), Prof. Goldschmidt (Christiania), and Prof. Bokay (Budapest). Congratulatory messages were also sent from Holland, Spain, U.S.A., and other countries.

After expressing his thanks for the addresses and messages Prof. Max Planck gave a survey of the development of German science during the past hundred years. Referring to the World-War, he said that one possession has not been lost by the German nation, namely, its national unity. The reconstruction of Germany's prosperity and the rebirth of German culture are not possible without German science. Many of the most important inventions which are used in modern industrial life, such as wireless telegraphy, the fixation of atmospheric nitrogen, the Röntgen rays, had been discovered in purely scientific laboratories. It is necessary to spread among all the nations of the world the conviction that the preservation and extension of purely scientific research in Germany is as necessary for the welfare and happiness of that country and the whole world as the development of industry and the production of raw materials. Scientific work is international in its nature, and therefore well fitted for creating and furthering mutual understanding and peaceful co-operation among the peoples of the world. The German men of science and physicians were ready to respond to frank and honest approaches made by foreign fellow-workers, but they would naturally not think of begging for admission where they were not wanted.

The subject of the first general address was the theory of relativity. Prof. Einstein himself had originally intended to be present, but he was prevented from appearing by his journey to the East. It may be mentioned that a protest against this subject, as not yet ripe for scientific discussion, had been lodged by a number of well-known men of

science of Germany and other countries. The lecturer was Prof. von Laue (Berlin), and he stated that the questions with which the theory of relativity is concerned are as old as science and scientific research. The modern problem is whether it is possible to ascertain an absolute velocity of any moving body. The transmission of light and electricity through space, even in a vacuum, has led to the assumption of an æther. All experiments, however, which have been made in order to discover how great is the velocity of the earth with respect to the æther have failed. The special or restricted theory of relativity, which maintains that it is impossible to ascertain any absolute velocity, has therefore been generally accepted by physicists.

It is a different question with the much more complicated and difficult general theory of relativity of Einstein. This is concerned with the old problem of the force of gravitation. Here mathematical processes have to be introduced which no physicist had thought of applying before Einstein. Though this part of the relativity theory has not yet been established so as to exclude every possibility of doubt, it can be regarded as an extremely valuable stimulus to further research.

This lecture was followed by an address by Prof. Schlick (Kiel) on the philosophical importance of the theory of relativity. He stated that the theory, though originally devised only to explain physical phenomena, has a great philosophical importance. The philosophical tendencies of Einstein's thinking pointed to a kind of positivistic philosophy, a philosophy of pure experience which takes no account of so-called elements or substances, and regards as the ultimate facts of all happening the observed events themselves. We may say that the period of the separation of philosophy and science is ended and that they are beginning to approach each other again.

On September 19 the first subject treated was that of heredity, and Prof. Johannsen of Copenhagen gave a survey of the work done during the past century in this field. The conclusion he comes to is that no positive result has been obtained in regard to the great questions of the origin of species and their evolution. A destructive criticism, however, of the chief ideas of both Darwin and Lamarck has been achieved, and the belief in natural selection as well as in a gradual fixation by heredity of qualities obtained by adaptation has been thoroughly shaken. Prof. Meisenheimer of Leipzig showed the results of experiments in crossing flowers, insects, and guinea-pigs. He explained the various connecting links, the mixed types, and described cases of reversion. His conclusion is that the experiments are subject to many chance influences and not very certain. It has been impossible, so far, to carry out all the calculable experiments; in many cases it will be necessary to resort to statistics.

Great interest was aroused by the lecture of Dr. Lenz of the University of Munich, on heredity in the human race. In this field, he stated, no experiments are possible. The only materials available are comparative observation of animals and plants and vital and genealogical statistics. The validity of Mendel's law has also been proved in the case of man; further, it is certain that no acquired qualities are inherited. In regard to the determination of the sex of unborn children, Dr. Lenz said that we can to-day already predict with a great degree of accuracy

the inherited qualities of children. There is no spontaneous degeneration and no ageing of a race, though the transmitted substance may be damaged by such poisons as alcohol and tobacco. Race-suicide among the educated classes is threatening the continuance of our civilisation. In order to lead to practical results in improving the race, racial biology must be supported by the State.

A very interesting series of lectures was given on the action of electrolytes on the organism. The first of these, entitled "Colloids and Ions," was delivered by Prof. Wo. Ostwald of Leipzig, and it provided the starting-point for a number of addresses. Prof. Hoeber, Kiel, dealt with the effect of the ions on physiological surfaces. We know to-day that no organ of the human or animal body, no plant, and no micro-organism reacts normally if the ions in the neighbourhood of the cells are not present in the proper proportions. The heart beats abnormally if it is surrounded by a minute excess of potassium ions or calcium ions. The corpuscles of the blood, in the same circumstances, may perish prematurely, or in the plant, growth may be abnormal. The ions are carriers of electric charges and they are active in all processes of stimulation of living tissues by means of electric currents. Their movements are also the cause of the curious electric currents which all living beings are capable of producing, and which represent the highest degree of excitement. The explanation of the nature of the effect of the ions is of the greatest importance for the proper understanding of the phenomena of life.

It is a curious fact that the ions need not penetrate into the living cells themselves. The conclusion is that they react with the surfaces of the cells, the "physiological boundaries." Three groups of phenomena were discussed. In the first instance, the cells themselves carry electric charges, and they interact with the charges of the ions. A result of this may be clotting, or "agglutination," as, for example, in the well-known case of the clotting of the blood-corpuscles during pregnancy. Secondly, the interaction of the salt-ions and the cell-surfaces produces the bio-electric currents which have been referred to above. In a model the substance of the cell-surfaces may be replaced by organic oils, and by bringing these oil films in contact with various salts the electro-physiological phenomena may be well imitated. Thirdly, a change in the composition of the normal mixture of ions on the surface of the cells alters the power of transmission of the surface, so that the normal diffusion between the inside of the cell and the surrounding fluid is disturbed. These results show that medical science will have to study these purely physico-chemical phenomena in order to be able to explain fully and deal properly with the processes of life.

Prof. Spiro of Basel, in dealing with the same subject, stated that every electrolyte seems to play a special part in the organism. Especially the effect of the small ions of water and of the colloid electro-

lytes must be studied. For health there must be a proper equilibrium of all the necessary ions.

Quite a sensation was caused by the lecture of Prof. Mayer of Hamburg on the new preparation against trypanosome diseases, "Bayer 205," produced and manufactured by Friedrich Bayer, Leverkusen (near Cologne). This new drug, which is said to contain neither arsenic, antimony, mercury, nor any other inorganic therapeutic reagents, has been extensively tested, both in Europe and tropical countries, and found to give excellent results in advanced stages of sleeping-sickness and other trypanosome diseases. A station for further experiments has been fitted up in South Africa.

In the geographical section Dr. Sven Hedin lectured on his travels in Tibet, summarising the results contained in his various works and producing a great number of fine lantern-slides. The lecture was enthusiastically received.

A great number of papers was read by eminent medical workers on special subjects. Prof. Flechsig gave a survey of his well-known studies in mental pathology in a lecture on the localisation of the brain functions. Many lectures were also delivered on technical and industrial subjects, such as workshop control by means of optical measuring instruments and modern methods of rapid reception and despatch of wireless messages.

The two lectures on enzymes, by Profs. Willstätter of Munich and von Euler of Stockholm, were well attended and full of interest. Prof. C. Neuberg of Berlin lectured on recent advances in the study of fermentation.

A special feature of the congress was the lecture by Prof. Wilhelm Ostwald of Leipzig on his new methods of quantitative determination of colours. Based on the Law of Fechner, his system of colours includes the dull colours which Helmholtz excluded. The colours of our environment cannot be measured by wave-lengths, but only by means of revolving coloured discs with a variable black sector. New was the communication that we nowadays no longer distinguish six principal colours, but must assume eight, which number agrees with Fechner's Law.

Space forbids more than a short reference to the valuable lecture by Prof. Svante Arrhenius of Stockholm on physical law in the cosmic-chemical processes, by Prof. V. M. Goldschmidt of Christiania on the metabolism of the earth, and by Prof. Nernst of Berlin on photo-chemical processes. In the last of these it was stated that Einstein's law of photo-chemical equivalents no longer holds good. Light does not produce a primary splitting up of the chemical substance, but an addition of energy. Our photographic plates would have to be 6000 times more sensitive in order to approach to the ideal.

Many more valuable lectures on special subjects were delivered. The town of Leipzig showed its splendid hospitality and provided entertainments and many occasions for social and personal intercourse. B. Rassow.

### The Present Position of Darwinism.

ONE of the discussions which aroused most interest during the British Association meeting at Hull was that held jointly by the botanical and zoological sections on "The present position of Darwinism." There was a large attendance, the discussion being presided over by Prof. H. H. Dixon, who was supported by Dr. E. J. Allen. The theory of the origin of species by natural selection, which has already been assailed by the geneticists, was attacked

from a different point of view by Dr. J. C. Willis and Mr. Udy Yule, who treated the subject with special reference to geographical distribution and the statistical analysis of genera and species. During the discussion the older view as to the significance of natural selection was stoutly maintained by some speakers.

After a few introductory remarks by Prof. Dixon, the discussion was opened by Dr. J. C. Willis, who

spoke of "The inadequacy of the theory of natural selection as an explanation of the facts of geographical distribution and evolution." Dr. Willis pointed out that Darwin's immortal service to science consisted in the firm establishment of the doctrine of evolution. This was effected by devising the mechanism of the natural selection of infinitesimal variations, the principle usually known under the name of Darwinism. This theory involves many assumptions: among others, that such variations are (1) continuous, (2) hereditary, (3) differentiating, (4) selected, and (5) that the necessary differentiating variations for the associated characters appear together. For all of these the proof is as yet insufficient.

Dr. Willis proceeded to consider the extent to which natural selection of small variations could be held to explain the facts of geographical distribution, morphology, and evolution, special reference being made to the grasses and to the Chrysomelid beetles. It was then pointed out that natural selection was helpless to explain the differences in distribution of closely related species, which, on the other hand, could be explained on the hypothesis of "Age and Area"—*i.e.* that the area occupied by any group of allied species (at least ten) depends chiefly upon the ages of the species. On this hypothesis predictions could be made which were found to be justified by facts. Dispersal of species is held to be mainly mechanical: so much dispersal in so much time. This suggested the further hypothesis of "Size and Space"; that, in groups of ten allied genera, the total space occupied goes with the total number of species. If this be true, whatever phenomena are shown by "Area" should also be shown by "Size." This in fact is shown to be the case when the number of allied species occupying areas of increasing size and the number of species in allied genera are plotted in the form of curves. The shape of the curves is invariably uniform. But sizes of genera are clearly the result of evolution. According to the theory of natural selection, the sizes of genera must depend upon their success, and it is, therefore, inconceivable that they should show such uniformity of expression. Such facts, however, are easily explained by the hypothesis that geographical distribution and evolution extend with age—*i.e.* that the factors causing them act at a more or less uniform rate. Natural selection, which is essentially differentiating, cannot explain these facts.

In consequence, however useful it may be to explain details of certain adaptations, and although everything at birth must pass through the sieve of natural selection, it seems that the latter principle must be abandoned as an important factor in geographical distribution and evolution. Finally, Dr. Willis considered it necessary to accept large mutations as being of greatest importance in evolution. In his opinion Guppy's theory of differentiation should replace the Darwinian position that evolution has proceeded from individual through variety to species, genus, etc., for the theory of "Age and Area" showed clearly that the family is older than the genus, and that the genus is older than the species.

Mr. G. Udry Yule spoke upon "A mathematical conception of evolution based on the theory of Age, Size, and Space." He suggested that if the size of the genus be considered an index of its age, species might be regarded as thrown by the genus much as offspring are thrown by a stock, and that the number of species originating from a given initial species will increase in geometric ratio with the time. The forms of frequency distribution for numbers of genera with numbers of species were shown to be in accordance with the facts, and the possibility was suggested of determining from such

distributions the ratio between the rates of increase of genera and species and the age of the family in terms of the doubling period for species.

Mr. C. Tate Regan stated that in his special study of fishes he had formed conclusions as to the origin and relationships of species and genera which were quite different from those of Dr. Willis. He pointed out that the hollow curves of the previous speakers were extreme types of asymmetrical curves which could also be obtained from many sorts of data—*e.g.* by plotting graphically the wealth of the community, grading from many poor to few very rich, or from the numbers of occurrences of surnames in the London Telephone Directory. All these curves were simply graphic representations of certain facts the meaning of which could be ascertained only by detailed analysis. According to his own view, the first step in the origin of a species had been not a change of structure but some form of isolation. The extreme mutationists, who thought that adaptations originated as large transformations without relation to use or environment, seemed to have returned to the special creation theory. Darwin's theory of evolution was that species had been modified by the natural selection of slight variations, aided by the inherited effects of use and disuse, and, in an unimportant manner (so far as adaptations were concerned) by the direct action of the environment. That theory was put forward by a man who knew the facts to be explained. Mr. Tate Regan claimed that Darwin's theory explained them and that no other theory stood the test.

Prof. W. Johannsen spoke from the point of view of a geneticist. He pointed out that selection could not produce anything, but it should be borne in mind that Darwin's belief in a productive power of selection was fully logical from the naive view of his time. The mutations which we knew did not explain the nature of evolution or the origin of large differences such as the differences between families. Modern genetics could scarcely contribute to a solution of the main problems of evolution, but it seemed to have cleared the ground from the erroneous Lamarckian and Darwinian views. He himself and, he thought, most geneticists were agnostics as to the mechanism of evolution.

Mr. J. T. Cunningham thought that natural selection was "as extinct as the dodo," and that the origin of species was due to mutations. Specific characters were for the most part useless, but other groups might be distinguished by adaptive and non-adaptive characters. He discussed adaptation, which he considered to have arisen in a Lamarckian manner. Modern discoveries concerning internal secretions showed how many adaptations exhibiting recapitulation might have been produced by stimuli and functional exercise.

Dr. H. Wager urged that there was more in the theory of natural selection than was implied by Dr. Willis and Mr. Cunningham. Fluctuating variations were dismissed from having evolutionary significance, but mutations were not necessarily large. He reminded the audience that an alternative title given by Darwin to "The Origin of Species by means of Natural Selection" was "The preservation of favoured races in the struggle for life," which might be interpreted in modern terms as "The preservation of favourable mutations."

Prof. E. B. Poulton discussed the theory of "Age and Area" in relation to mimicry, and pointed out that in certain African butterflies the younger form is distributed over a much wider area than the ancestral type.

Dr. Chalmers Mitchell supported Mr. Tate Regan, and considered that Dr. Willis had presented merely

a caricature of natural selection. He appealed for the study of individual life forms.

Prof. A. C. Seward considered that the great uniformity of the curves presented by Dr. Willis and Mr. Udney Yule was suspicious, for Nature had not been uniform. He pointed out that, as regards conifers and ferns, study showed that the forms existing now in restricted areas were the oldest and not the youngest.

Mr. Julian Huxley contended that many factors played a part in evolution. Species characters should be analysed by the methods of genetics and physiology before it could be said which were useless. Apparently useless characters in the Gipsy moth were correlated with physiological differences, such as rate of growth, which harmonised with the environment.

Prof. R. Ruggles Gates considered that Dr. Willis's view was a corollary of the mutation hypothesis, and emphasised the importance of the extinction of forms as a factor in evolution.

Prof. W. J. Dakin suggested that biologists were on the threshold of a new line of study of evolution from the physico-chemical side. He believed that the faculty of evolution was as much a character of

the organism as irritability or reproduction, and pointed out that natural selection was really natural elimination, the production of characters being inherent properties.

Dr. A. B. Rendle said it was almost impossible to say what characters were useful or not, and, in view of the limited space available, considered that the multiplication of genera and species in geometrical progression was unlikely.

Prof. J. Stanley Gardiner agreed that evolution was an inherent property of protoplasm, and raised the question as to why forms of life died out. He expressed approval of the main thesis of "Age and Area."

In reply, Dr. J. C. Willis pointed out that there must be some reason for the uniformity of expression as given in his statistical work. He accepted the phrase "Natural Elimination" instead of "Natural Selection."

In concluding the discussion, Prof. H. H. Dixon pointed out that both "Natural Selection" and "Age and Area" were essentially truisms, but none the less required explicit statement and demonstration.

### Effects of Local Conditions on Radio Direction-finding.

THE methods used for finding the direction in which Hertzian waves are incident at a radio station have now attained a high accuracy, the maximum error being well under one degree. It does not follow, however, that the methods give the direction of the sending station to the same accuracy. The waves sent out may have suffered reflections from all kinds of conductors before they reach the receiving station. Hence, especially at night-time, the apparent direction generally differs very appreciably from the true direction. A preliminary report on this subject, communicated by the Radio Research Board, was read on November 8 to the Radio section of the Institution of Electrical Engineers by Messrs. Smith-Rose and Barfield. They classify the causes of distortion under two heads: First, those which are vaguely classed as night-effects and occur between sunset and sunrise. They are sometimes as large as 20°, and little is known as to their cause. Hence in practice radio-direction finding is restricted to day-time. The second causes of error are those due to conducting substances in the immediate neighbourhood of the search coil. In one experiment a metal tube 50 ft. long, semicircular in cross-section, and of radius 3 ft. 6 in. was used. When the coil was at a distance of 15 ft. from either end errors became appreciable, and when placed 15 ft. inside the tube the error was as great as 29°.

Experiments were also made on board ship, as radio-direction finding is of great value in navigation.

It was found that when the waves came fore-and-aft or athwart the ship there was no error, but that in intermediate positions the errors were sometimes as great as 22°. As these errors are approximately constant, corrections can be applied as in the case of the magnetic compass. Curiously enough it was found that underground metal work in the neighbourhood had a very appreciable effect on the apparent direction of the incoming waves. The Aberdeen University direction-finding station, for example, was erected on what was thought to be a favourable site. The errors found, however, indicated the existence of a long strip of metal in the neighbourhood in a definite direction. The authors investigated the cause and found that a sewer in the neighbourhood, which was in the given direction, was supported by a strip of steel 6 ft. wide, 300 ft. long, and 8 ft. below the surface.

Overhead wires also caused appreciable but variable errors, which the authors traced to variations of the telegraph and telephone circuits when in use. They investigated the errors produced by tuned aerials and trees. Trees when damp have small resistance, and so the oscillations set up in them affect the direction of the waves. A row of damp trees forms a very good conducting screen. It was noticed that the waves showed a tendency to move round large conductors. Owing to variable meteorological conditions a very large number of experiments had to be made before definite results were obtained. The authors are continuing their investigations.

### New X-ray Department at Manchester.

SIR HUMPHRY ROLLESTON, president of the Royal College of Physicians and of the Röntgen Society, opened on November 18 the new X-ray department of the Manchester Royal Infirmary, which is probably the most completely equipped department of its kind in this country. This has been made possible by two separate gifts of 5000*l.*, one by Mr. Robert McDougall and the other by an anonymous benefactor.

The occasion coincided with a joint provincial

meeting at Manchester of the Röntgen Society and the Electrotherapeutics Section of the Royal Society of Medicine; and a considerable number of members took the opportunity of inspecting the new equipment, which has been installed by Messrs. Watson and Sons under the direction of Dr. A. E. Barclay, senior radiologist to the Infirmary.

The new department is on the ground-floor, is well lighted and ventilated, possesses generous head room, and is cheerfully decorated, all features which are

stressed in the recommendations of the X-ray and Radium Protection Committee. Indirect lighting is employed, the ceilings being painted with white enamel.

Throughout the building high-tension wires are abolished. They are replaced by stout aluminium tubing, which eliminates brush discharges and prevents the formation of ozone, now known to be prejudicial to the health of the operators.

Most of the X-ray bulbs are contained in boxes which are covered with an adequate thickness of sheet lead. In addition, the walls are coated with a plaster containing a large admixture of barium sulphate, the result being a wall giving protection equivalent to that of about 8 mm. of lead.

Coolidge tubes and closed-core high-tension transformers are the order of the day, except in the treatment department, where the existing induction coils have been brought up-to-date.

In the screening-room a Sunic 10 K.V.A. oil-immersed transformer is installed. The new intensive deep therapy treatment of cancer is catered for by two separate 200,000-volt outfits, each of the twin-coil type—one a German set with dry insulation by Maison Schaefer, the other of the oil-immersed type by Newton and Wright.

There are a number of unusually elaborate screening-stands and couches, a novel development being the Potter Bucky couch, in which a lead grid is inserted between the patient and the photographic plate. The grid, while allowing direct X-rays from the bulb to pass, prevents the majority of the scattered radiation from reaching the plate, to the marked benefit of definition. A special portable X-ray equipment is provided for use in the wards of the hospital in cases where it is inadvisable to move the patient.

The lay-out of the department is well-nigh a model of its kind, being arranged so that the work progresses automatically to its finality. The day of black-painted walls for dark rooms is over; instead, we find a cheery lofty room which can readily be flooded with daylight when the room is not in use. Thermostatic control of the developing and fixing solutions, etc., is provided. There is also a fully-equipped demonstration room, so that doctors and students can watch the examination of cases without hampering the work. This demonstration room is also provided with a stereo-motograph, an ingenious instrument which automatically changes lantern slides by a press-button, so that the lecturer is independent of a lantern operator. The proportion of infirm patients requiring X-ray examination is one in five, so that business-like and orderly arrangements are very essential.

At the joint meeting Prof. Jacobaeus of Stockholm, Prof. W. L. Bragg and Prof. A. V. Hill, among others, contributed papers; and the enterprise of the two societies in departing from precedent by holding a meeting in the provinces met with great local appreciation and support.

### University and Educational Intelligence.

ABERDEEN.—Dr. A. W. Gibb has been appointed to the newly founded Kilgour chair of geology. This foundation is derived from a bequest under the will of the late Dr. Alexander Kilgour of South Loirston, supplemented in the will of his son, through whose death it has now become available. In accordance with the terms of the trust deed, junior and senior scholarships in natural science have also been instituted. Prof. Gibb, who has an intimate knowledge

of the geology of the north of Scotland, has been in charge of the teaching of the subject since 1899, first as a member of the staff of the natural history department, and since 1908 as head of an independent department of geology. The teaching of the subject in Aberdeen is associated with the names of James Nicol and Alleyne Nicholson.

Prof. E. W. Hobson has completed, during the present month, his second series of Gifford lectures on "The Domain of Natural Science." In this series, which concludes the course, he has reviewed the whole field of natural science, and has dealt with its relation to general thought and to theism. The lectures will appear in book form.

LIVERPOOL.—We understand that Prof. F. Carey is to retire at the end of the present session. Prof. Carey is head of the department of pure mathematics at the University, and was one of the original professors on the first staff of the University College.

THE Strasbourg correspondent of the *Times* states that the diploma of doctor *honoris causa* of the University of Strasbourg has been conferred upon Sir James Frazer, author of "The Golden Bough."

ACCORDING to the Paris correspondent of the *Times*, the degree of doctor *honoris causa* of the University of Paris has been conferred on the following: Prof. Bordet, professor of bacteriology in the University of Brussels; Prof. M. Lugeon, professor of geology in the University of Lausanne; and Prof. A. Michelson, professor of physics in the University of Chicago.

By the will of Sir William Stevenson Meyer, High Commissioner for India and formerly Chief Secretary to the Government of Madras, who died on October 19 last, sums of 3000*l.* each are bequeathed to University College, London, "for the encouragement of proficiency in European history and in the history and geography of India," and to the University of Madras "for promoting the study of history and economics."

A CONFERENCE on the teaching of science in schools and colleges, which owed its initiation to Miss Winifred Smith, president of the Association of University Women Teachers, and its organisation to the joint efforts of the Association of Science Teachers and the A.U.W.T., was held on Saturday, November 25, at University College. During the morning session, with Miss Smith in the chair, the more general aspects of science teaching and the relationship between the work in the school and in the university were discussed. In the opening paper Sir William Tilden dealt with science in the school and raised a plea for work of wider and less specialised type, with a place for the history of the growth of knowledge. His personal reminiscences added much to the interest of the paper. Sir William Bayliss and Prof. J. R. Partington both expressed themselves in hearty support of wider range in the science work. The last speaker, from the point of view of university work, considered that the more specialisation was pushed in the school, the worse the result later. The condemnation of specialisation was continued in the papers of both Miss Thomas and of Miss Drummond. The first speaker dealt with the preparation of the student for the work of teaching science and deplored the tendency to specialise too early at the university; she considered the conditions of the Burnham scales enhanced this. The afternoon session included a paper upon the teaching of biology by Mr. A. G. Tansley, and papers upon

schemes of work in physics and nature study by Miss Lees and Mr. Latter respectively. The duty of the school to instruct future citizens regarding the functions of their own bodies was raised by several speakers. During the day, through the kindness of the college authorities, there was an opportunity to visit the laboratories, which was greatly appreciated by the members of the well-attended conference.

The *Chemiker Zeitung* of September 28 publishes particulars as to the number of students in German universities. The total number had increased from 40,000 to 60,000 at the outbreak of war. At the end of the war the number was 90,000, and in the summer of 1921 it was 87,147. At present it is 82,668. The *Technischen Hochschulen* had 12,000 students before the war, in 1920 they had 22,976, and last winter 25,556. The division into faculties has undergone changes; the warnings of overcrowding in some faculties have had some effect but the stream of superfluous students has mainly been diverted into other faculties, which are also now hopelessly overcrowded. The following comparison is given with pre-war conditions:

Faculty.	1914.	1922.
Evangelical Theology . . . . .	4,370	2,974
Catholic Theology . . . . .	2,050	1,795
Legal Science . . . . .	9,840	16,834
Medicine . . . . .	16,048	15,110
Dentistry . . . . .	976	4,167
Philosophy and Philology . . . . .	14,400	12,823
Mathematics and Natural Sciences . . . . .	8,132	9,257
Pharmacy . . . . .	1,100	1,112
National Economy . . . . .	3,836	17,714
Forestry . . . . .	..	490

The following refer to technical students:

Faculty.	1914.	1922.
Architecture . . . . .	2,193	1,811
Constructional Engineering . . . . .	2,767	3,311
Mechanical Engineering . . . . .	3,118	8,306
Electrotechnics . . . . .	1,397	5,129
Mathematics and Natural Sciences . . . . .	1,544	3,735
Mining and Metallurgy . . . . .	576	1,234
Naval Engineering . . . . .	234	365
General . . . . .	493	1,483

It is further stated that the present-day student does not tend to the same extent as before the war to study in the large cities.

LIFE in the universities of Russia to-day is described by Harold Gibson, Chief Administrator, International University Relief in Russia, in a brief note circulated for the purpose of obtaining further help for their professors and teachers. While conditions in Moscow and Petrograd are said to have improved materially during the past year, they are still deplorable in the provinces. Professors and teachers have been receiving from the Government food packets (academical *pyokh*), but it is doubtful whether this supply, inadequate and irregular during the summer, will not cease altogether during the winter. In addition they receive, but not regularly, pay on a scale sufficient to provide food (millet gruel with sunflower oil, soup made from salt fish, and potatoes fried in oil) for about one week per month. All clothing they could possibly do without during the summer is said to have been sold. As for housing, it is seldom that a professor's family has more than two rooms to live in and very frequently they have only one, while in some universities the professors live in their lecture-rooms or laboratories. It is astonishing that under such conditions work

of any value can be done, but we are assured that not merely is a respectable standard of instruction maintained but valuable research work has been done. An appeal by the Universities Committee of the Imperial War Relief Fund issued in September last met with an immediate and generous response, but much more is needed urgently—money, gifts in kind of food, clothing, and clothing material, books, scientific journals, and laboratory equipment. Full particulars can be obtained from Miss Iredale, Organising Secretary of the Committee, General Buildings, Aldwych, London, to whom cheques made payable to the Hon. Cecil Baring should also be sent.

THE Council of the League of Nations has approved and published a report on "The condition of intellectual life in Austria," specially prepared by Prof. de Reynold, of the University of Berne, during the month of August. It describes a struggle for existence carried on in circumstances of increasing difficulty which threaten to overwhelm completely Austrians who are dependent for their means of livelihood on intellectual work. "The winter of 1922-1923 will without a doubt be decisive." The University of Vienna is at present saved from having to close its doors by a Government subsidy of 1000 million crowns (the purchasing power of which is about one-twentieth part of the subsidy it was receiving before the war), but all practical scientific work has become impossible owing to lack of funds for the purchase of essential requisites. The Universities of Graz and Innsbruck and other institutions of higher education are in a similar or worse plight. Innsbruck formerly attracted many foreign students, but last year none except Austrians attended, and there is talk of closing, if not the whole university, at least the school of medicine. Academies and scientific societies continue to meet but are unable to publish reports except when, as occasionally happens, a foreign patron provides funds for the purpose. The monthly salary of a university professor is on an average about enough to live on for twenty days, and he may receive students' fees up to a sixth of his salary. Lectures go on in Vienna up to 10 P.M. to enable students to earn money by manual work (the only kind that is well paid) during the day. In the circumstances it is surprising that last year the University of Vienna still had nearly 10,000 students.

In "Home Economics in Rural Schools" and "Modern Equipment for One-Teacher Schools" (Home Economics circular 13 and Rural School leaflet 3, 1922, of the Bureau of Education, Washington) a prominent place is given to the provision of hot lunch for the pupils. It has been found that in such schools the most satisfactory method of imparting a knowledge of foods and household sanitation and inculcating right health habits is in connexion with the preparation and service by groups of children of a hot lunch for the whole school. It is claimed that the time taken from the regular school work is not more than ten minutes daily, and that the beneficial physical effects of the hot food itself, and the moral effect of the co-operative social activity involved, have been very marked. It is recommended that the instruction in home economics should be related to the geography, arithmetic, and physiology lessons. In "Reorganization of Home Economics in Secondary Schools" (Bulletin 5, 1922) it is stated that the most satisfactory and economical management of the school lunch in any school, large or small, is attained by placing it under the direction of the head of the home economics department.

## Calendar of Industrial Pioneers.

**December 3, 1863. John Watkins Brett died.**—A pioneer of submarine telegraphy. Brett obtained permission in 1847 from Louis Philippe to establish connexion by cable between England and France, a project which was first carried out in 1850.

**December 4, 1804. Philippe Le Bon died.**—In France, Le Bon is regarded as the inventor of lighting by gas. Educated for the Government service, in 1794 he became a professor in the *École des Ponts et Chaussées*. Three years later he was able to light his house at Bruchay by the distillation of wood, and in 1799 he was granted a patent. On December 4, 1804, he was found in the Champs-Élysées murdered by an unknown hand.

**December 6, 1777. Johann Andreas Cramer died.**—Regarded as the greatest assayer of his time, Cramer was born in Quedlinburg in 1710, taught assaying in Leyden and London, and afterwards was councillor of mines and metallurgy at Blankenburg. His "*Docimasia*" was published in 1736 and his "*Elementa Artis Docimasticæ*" in 1739.

**December 6, 1892. Werner von Siemens died.**—The eldest of the famous Siemens brothers, Werner Siemens was born at Lenthé, Hanover, on December 13, 1816, and in 1838 became an artillery officer. Distinguished for his scientific attainments, with John Georg Halske (1814-1890) he founded in 1847 the firm of Siemens and Halske at Berlin, and the following year with Himly laid the first telegraph line in Germany. He made many discoveries in electricity, in 1866 gave half a million marks for the founding of an Imperial Institute of Technology and Physics, and in 1888 was ennobled.

**December 7, 1880. Henry R. Worthington died.**—The original inventor of the direct-acting steam pump, of which many thousands of various types are manufactured annually, Worthington took out his first patent in 1841, and in 1845 founded the Worthington Hydraulic Works of New York, which became the leading establishment for the construction of steam-pumping machinery in the United States.

**December 7, 1894. Ferdinand Viscomte de Lesseps died.**—The originator and constructor of the Suez Canal, one of the great engineering works of last century, de Lesseps was born at Versailles in 1805, and at the age of twenty joined the French diplomatic service. Among other places he served at Cairo and Alexandria. Obtaining a concession from Said Pasha in 1854, he started the canal in 1858; a vessel of 80 tons passed from the Mediterranean to the Red Sea in 1867, and on November 17, 1869, the canal was formally opened. A colossal statue of de Lesseps stands at Port Said. De Lesseps also launched the scheme for the Panama Canal, and when an old man of eighty-eight was with the other directors found guilty of mismanagement and sentenced to a term of imprisonment, which, however, was not enforced.

**December 8, 1870. Thomas Brassey died.**—At a period when railways were first coming into extensive use, Brassey with various partners carried out some hundreds of important contracts including railways in England, France, Italy, Canada, Australia, Argentine, and India.

**December 9, 1814. Joseph Bramah died.**—Known for his invention of a safety lock, a beer engine, the hydraulic press, and a machine for numbering and dating banknotes, Bramah was a native of Yorkshire, but for many years was one of the leading mechanicians in London.

E. C. S.

## Societies and Academies.

LONDON.

**Linnean Society, November 2.**—Dr. A. Smith Woodward, president, in the chair.—A. B. Rendle: Early specimens of the dahlia and chrysanthemum from the Banksian Herbarium.—J. S. Huxley: The courtship of birds.—B. Daydon Jackson: The use of the name *Forstera* or *Forsteria*. Both names were used by Linne on a sheet in his herbarium with his note *Fostera vaginalis* on a sheet which formerly had a grass-like plant glued upon it and therefore was widely separated from the Styliaceoous genus which at the present day bears the name *Forstera*.

**Aristotelian Society, November 6.**—Prof. A. N. Whitehead, president, in the chair.—A. N. Whitehead: Uniformity and contingency (presidential address). Our awareness of Nature consists of the projection of sense-objects into a spatio-temporal continuum either within or without our bodies. But "projection" implies a sensorium which is the origin of projection. This sensorium is within our bodies, and each sense-object can be described as located in any region of space-time only by reference to a particular simultaneous location of a bodily sensorium. The process of projection consists in our awareness of an irreducible many-termed relation between the sense-object in question, the bodily sensorium, and the space-time continuum, and it also requires our awareness of that continuum as stratified into layers of simultaneity, the temporal thickness of which depends on the specious present. If this account of Nature be accepted, then space-time must be uniform, for any part of it settles the scheme of relations for the whole irrespective of the particular mode in which any other part of it, in the future or the past or elsewhere in space, may exhibit the ingression of sense-objects. Accordingly, the scheme of relations must be exhibited with a systematic uniformity. We have here the primary ground of uniformity in Nature.

**Mineralogical Society, November 7** (anniversary meeting).—Dr. A. Hutchinson, president, in the chair.—W. A. Richardson: The frequency-distribution of igneous rocks in relation to petrogenic theories. The distribution of igneous rocks shows a separation into two primary types, probably corresponding to two primary earth shells, which have originated under early planetary conditions. All other rocks are normally distributed about the two primaries, and the probable cause of such a distribution is fractional crystallisation. The frequency-distribution likely to result from different petrogenic processes is examined and discussed.—Miss I. E. Knaggs: The connexion between crystal structure and chemical constitution of carbon compounds. In certain simple substitution products of methane, the crystal symmetry may be predicted from the known configuration of the chemical molecule. The symmetry of a molecule of the type  $CX_4$  is that of a regular tetrahedron, X being either a univalent atom or a group of atoms, which does not destroy the trigonal symmetry about the bonds from the central carbon atom. Compounds of this type crystallise in the cubic system. Compounds in which X is a more complex group, but sufficiently symmetrical to maintain tetragonal symmetry, crystallise in the tetragonal system, most frequently in the holohedral class, in which case the crystal is considered to be built up of cells each containing eight molecules. Molecules of the type  $CX_3Y$  have one axis of trigonal symmetry, and this symmetry is preserved in the crystal, except when X is hydrogen. The orthorhombic symmetry of molecules of the type  $CX_2Y_2$



is maintained in the crystal.—Dr. G. T. Prior: The meteoric iron of Karee Kloof, Cape Province, and the meteoric stone of Leeuwfontein, Pretoria, South Africa. The meteoric iron, of which a mass of 92 kgm. was found at Karee Kloof, is a coarse octahedrite containing 8.27 per cent. nickel; the Leeuwfontein meteoric stone of 460 gm. which fell on June 21, 1912, is an intermediate chondrite.

**Zoological Society**, November 7.—Prof. E. W. MacBride, vice-president, in the chair.—C. S. Elton: The colours of water-mites.—E. B. Poulton: Commensalism among Crustacea. An account of experiments conducted at the Laboratory of the Marine Biological Association, Plymouth, in 1890, showing commensalism may be beneficial to Crustacea.—G. M. Vevers: Nematode parasites of mammals from the Zoological Society.—W. J. Kaye: New species of Trinidad moths.—C. F. Sonntag: On the myology and classification of the wombat, koala, and phalangers.—E. G. Boulenger: Description of a new lizard of the genus *Chalcides*, from the Gambia, living in the Society's Gardens.

**Geological Society**, November 8.—Prof. A. C. Seward, president, in the chair.—R. D. Oldham: The earthquake of August 7, 1895, in Northern Italy. This earthquake, although nowhere more than a feeble shock, was felt over an area measuring about 160 miles across and covering some 15,000 to 20,000 square miles in Lombardy and Tuscany. There is no indication of a central area of greatest intensity; reports indicating an intensity of IV° (Mercalli scale) are scattered over the whole area, and reports of sounds and of noticeable vertical movement are similarly distributed. The nature of the disturbance was akin to that in the outer parts of the seismic area of great earthquakes. The depth of the ultimate origin of the earthquake must have been of the order of 100 miles or more.—R. D. Oldham: The Pamir earthquake on February 18, 1911. This earthquake was felt over an area of about 250 miles in diameter; the region included by the VIII° R.F. isoseist measured about 40 miles across. Over the greater part of this area destruction was extreme, and the hillsides were seamed with landslips. Aftershocks were recorded, providing further evidence that the earthquake had its origin at a considerable depth below the surface. The great landslip, though determined by, and not determining the earthquake, as has been thought in the past, may have influenced the distant seismograms by setting up surface-waves which, superimposed on those directly due to the earthquake, may account for the unusual size of the long (or surface-) waves, as compared with the preliminary tremors.—F. Dixey: The geology of Sierra Leone: About half of the Protectorate of Sierra Leone is composed of potash-bearing granites and granite-gneisses, while the remaining areas are occupied equally by older schists and gneisses and the ancient sedimentary Rokell River Series. The older schists and gneisses, including a charnockitic series similar to that of the Ivory Coast, represent a complex of highly metamorphosed sedimentary and igneous rocks. The Rokell River Series has a lower conglomeratic division that rests unconformably upon the crystalline rocks. The rocks of the series are usually much disturbed, and show every gradation from slight deformation to intense dynamic metamorphism. The southern margin of the great series of horizontal sandstones of French Guinea forms, near the Anglo-French boundary of the Protectorate, the Saionia Scarp, and thus the formation within the Protectorate bears the name Saionia Scarp Series. It rests alike with striking unconformity upon the Rokell River Series and the crystalline rocks.

**Association of Economic Biologists**, November 10.—E. S. Russell: The work of the Fisheries Laboratory at Lowestoft. The main task of the past two years of the Laboratory and research ship *George Bligh* has been the working out of the life-history and food supply of certain economic fishes. Investigations on plaice in the North Sea have shown that there are more plaice than before and they were markedly larger and older than the pre-war plaice. In connexion with cod and herring investigations a quantitative study of the bottom fauna, carried out by Petersen's method on an area of the Dogger Bank, showed that the food supply was very patchy. Large patches of *Maetra (Spicula) subtruncata*, which is a plaice food, were found. The fauna belonged generally to the Venus community, with a tendency to deep Venus. Investigations of the early stages of the herring led to searching for spawning areas. Useful pointers have been the catches of spawn-gorged haddock landed on the East Coast. Larval and post-larval forms were secured chiefly by using the Petersen young fish trawl. There is a spawning ground off the Lincolnshire coast, and others off the Northumberland coast, on the W. edge of the Dogger, and in the Southern Bight, etc. At an early stage young herring concentrate in inshore waters and go in shoals, which complicates quantitative investigations. The failure of last year's herring fishery on the E. coast of England is thought to be related to an abnormal influx of Atlantic water into the N. Sea. Concomitantly, changes occurred in temperature, salinity, and plankton fauna. Very young herring, even before the yolk sac is absorbed, prefer *Pseudocalanus* as food; a later stage takes *Temora*, and herring of whitebait size take *Eurytemora*.—S. F. Harmer: The present position of the whaling industry.

**Linnean Society**, November 16.—Dr. A. Smith Woodward, president, in the chair.—A. J. Wilmott: *Orchis latifolia*, Linn. (marsh orchid) from the Island of Oland, Sweden, obtained from the station in which it was found by Linnaeus in 1741. *O. latifolia*, L., 1753, was a general name for marsh orchids, but in 1755 this name was limited without varieties, and separated from *O. incarnata* and *O. sambucina*. The diagnosis is general, and comes from Linnaeus's article in Act. Upsal. 1740, where it applies mainly to unspotted-leaved plants. Linnaeus, referring to *O. latifolia* in 1755, says that the leaves are slightly spotted. This may refer to the decay spots on the plant in his herbarium, or to the hybrid forms with spotted leaves which occur where *O. pratermissa* and *O. maculata* occur together.—I. A. Sprague: Twin-leaves and other abnormalities in the common ash, *Fraxinus excelsior*. Specimens were shown with fasciated stems, bud-variation, accessory leaflets, confluent leaflets, twin-leaves and triplets, and other abnormalities. Twinning is probably caused by hypertrophy. Complete or partial suppression of one leaf of a pair does not necessarily disturb the opposite-decussate phyllotaxy.

**Faraday Society**, November 20.—Sir Robert Robertson, president, in the chair.—T. M. Lowry: Intramolecular ionisation. The introduction of electronic formulae based on the theory of octets has made it necessary to postulate a condition of intramolecular ionisation in a large number of compounds where the charges on the nuclei are not balanced by the enveloping electrons. Stability in oxy-acids depends on the presence of a positive charge on the central atom of the ion. This also increases the strength of the acid. A maximum of stability and

of strength is reached in acids containing four atoms of oxygen round the central atom of the ion.—**C. J. Smith**: On the viscosity and molecular dimensions of hydrogen selenide. Attention has recently been directed to the relations which exist between the molecular dimensions of those gaseous hydrides which have the same molecular number. In the series krypton, hydrogen bromide, hydrogen selenide, and arsine there were no data for hydrogen selenide. Two factors are necessary for the proper estimation of dimensions of a gaseous molecule, namely, the coefficient of viscosity, and its rate of variation with temperature. The viscosity of hydrogen selenide at atmospheric temperature has been measured, but the almost complete decomposition of the gas at steam temperature has prevented any trustworthy experimental determination of the temperature variation being made. The numerical results obtained confirm the supposition that the gaseous molecules  $\text{HBr}$ ,  $\text{H}_2\text{Se}$ , and  $\text{AsH}_3$  have a central atom which resembles an atom of krypton, and that the increase in  $A$  in passing along the series is to be attributed to the hydrogen nuclei which have become attached to the central atom. As the hydrogen atoms in the molecule multiply, the distance of each hydrogen nucleus from the centre of the molecule increases more and more rapidly.—**W. R. G. Atkins**: The hydrogen concentration of natural waters and some etching reagents in relation to action of metals. The results obtained are summarised as follows: Natural waters are usually between  $\text{pH}6$  and  $\text{pH}8.3$ , unless when rendered more acid by oxidation of sulphur from pyrites or by metallic salts. Bog pools may be as acid as  $\text{pH}5$ . Photosynthesis increases the  $\text{pH}$  value. Ferrous salts in solution become more acid on standing, with precipitation of ferric hydroxide. The latter is completely precipitated before ferrous hydroxide, as the solution is made progressively more alkaline. Even at  $\text{pH}7.1$  the precipitation of ferrous hydroxide is incomplete. Hence a trace of acid suffices to attack iron, and the hydroxide produced through hydrolysis is oxidised and precipitated. The hydrolysis equilibrium is thereby upset and acid is regenerated. Buffer mixtures and acids of relatively low hydrogen ion concentration might be used as etching agents.

## CAMBRIDGE.

**Philosophical Society**, October 30.—**Prof. A. C. Seward**, president, in the chair.—**H. Hartridge** and **F. J. W. Roughton**: Determinations of the velocity with which carbon monoxide displaces oxygen from its combination with the blood pigment hæmoglobin. The velocity of the reaction, which is considerable, was measured by utilising the fact that light displaces the system from equilibrium by reducing the amount of the carbon monoxide hæmoglobin in a solution of hæmoglobin containing oxygen and carbon monoxide. The relationship between the amounts of the oxy- and carbon monoxide hæmoglobin at any moment was determined by the reversion spectroscopy, which makes use of the fact that the wavelength of the  $\alpha$  band of the mixed pigment varies with the relative concentration of the pigments. Two methods of measuring the velocity of reaction were employed:—(a) The solution was caused to flow turbulently from a glass tube exposed to light, down a second glass tube in the dark. In this tube the equilibrium returned to its "dark" position, and from the rate of flow measurements by the spectroscopy give the relative amounts of oxy- and carbon monoxide hæmoglobin at any moment. (b) The solution remained in one vessel, the exposure to light being suddenly cut off, and the time measured

with a chronometer for the relationship between the oxy- and carbon monoxide hæmoglobin to reach a definite value as shown by the spectroscopy. Velocity constants were calculated, assuming the reaction to be expressible by a simple chemical equation. The temperature coefficients calculated from the results obtained at other temperatures agree closely, the mean value being 2.5. These results fit in with the view that the combinations of oxygen and carbon monoxide with hæmoglobin are of a simple chemical nature.—**G. H. Hardy** and **J. E. Littlewood**: Some problems of Diophantine approximation.—**J. Chadwick** and **C. D. Ellis**: A preliminary investigation of the intensity distribution in the  $\beta$ -ray spectra of radium  $B$  and  $C$ .—**C. G. Darwin** and **R. H. Fowler**: Partition functions for temperature radiation and the internal energy of a crystalline solid.—**J. E. Littlewood** and **E. A. Milne**: On an integral equation.—**E. V. Appleton**: The automatic synchronisation of triode oscillators.—**P. L. Kapitza**: Note on the curved tracks of  $\beta$ -particles.—**G. T. Walker**: Meteorology and the non-flapping flight of tropical birds.—**Major P. A. MacMahon**: The algebra of symmetric functions.

## DUBLIN.

**Royal Irish Academy**, November 13.—**Prof. Sydney Young**, president, in the chair.—**S. Young**: A note on azeotropic mixtures. It is now possible to predict, either with certainty or with considerable confidence, whether an alcohol of the methyl alcohol series not yet investigated can or cannot form a binary mixture of minimum boiling-point with hexane, benzene, or toluene, or a ternary azeotropic mixture with one of these hydrocarbons and water.

## PARIS.

**Academy of Sciences**, November 6.—**M. Albin Haller** in the chair.—The president announced the death of **E. Bouty**.—**L. Lindet**: Concerning the coagulation of latex. Remarks on a communication by **M. Vernet** on the effects of adding calcium chloride solution to the latex of rubber plants. In 1914 the author published an account of a similar action of calcium chloride in the coagulation of milk casein.—**Jean Effront**: The absorption of pepsin and hydrochloric acid by foods. Starting with the observation that certain filter papers proved to be active absorbents of pepsin, experiments have been carried out on the absorptive powers of various fruits and vegetables for pepsin and also for hydrochloric acid. The amounts absorbed were considerable, and vary with the fruit and with the acidity of the medium. The therapeutical aspects of these facts are discussed.—**Serge Bernstein**: The asymptotic development of the best approximation by polynomials of rational functions of degrees indefinitely increasing.—**Birger Meidell**: A problem of the calculus of probabilities and of mathematical statistics. A discussion of Techebycheff's theorem on the probabilities of errors greater than the average error with special reference to the calculus of probabilities and mathematical statistics.—**P. J. Myrberg**: The singularities of automorphic functions. A correction to the note of October 23 on the same subject.—**J. Le Roux**: Gravitation in classical mechanics and in Einstein's theory.—**Louis de Broglie**: Interference and the quanta theory of light.—**Paul Pascal**: The magnetic analysis of silicates and the silicic acids. From measurements of magnetic susceptibility of silicic acid in varying degrees of hydration it is concluded that all the forms of "hydrated silica" studied behave magnetically as mixtures of anhydrous

silica and water. There is no evidence in favour of the existence of any definite silicic acids in the hydrated silica.—**André Brochet**: The preparation of active nickel for organic catalysis. Three methods are described, the reduction of black nickel oxide by electrolytic hydrogen at 350° C. (an operation requiring 48 hours), or by heating either nickel formate or nickel oxalate to 250°–300° C. These three varieties of active nickel possess practically identical catalytic properties.—**A. Aubry** and **E. Dormoy**: An arsenical glucoside: diglucosidiodioxydiamo-arsenobenzene. The compound "606" has been made to combine with glucose and the reactions of the diglucoside formed are given. For therapeutic purposes the glucoside has the advantage as compared with "606" of being very soluble in neutral medium: it is also less alterable in air than the dioxidiamo-arsenobenzol.—**Pereira de Sousa**: The eruptive rocks of the Mesozoic and Cainozoic border of Algarve and their geological age.—**C. Kilian**: General sketch of the structure of the Tassilis of Ajjer.—**Albert Baldit**: Magnetic measurements in the south of France.—**Sabba Stefanescu**: The velocity of evolution and the general plan of structure of the crown of the molars of mastodons and elephants.—**Marc Bridel** and **Camille Charaux**: Centaureine, a new glucoside, extracted from the roots of *Centaurea jacea*. Details of the extraction and properties of the new glucoside are given. On hydrolysis, centaureine gives 33.7 per cent. of glucose (and no other sugar) and 70.8 per cent. of centaureindine.—**E. and G. Nicolas**: The action of hexamethylenetetramine on the higher plants.—**Marin Moliard**: The influence of salts of copper on the yield of *Sterigmatocystis nigra*.—**Adrien Davy de Virville** and **Fernand Obaton**: The opening and closing of persistent meteoric flowers. Persistent meteoric flowers are defined as those the floral parts of which show opening and closing movements during several days. These movements depend almost entirely upon the temperature. A reduction in the relative humidity of the air favours the opening of the flowers, but the effect is slight. Contrary to the views expressed by some physiologists light is without action.—**Alphonse Labbé**: The variations in the concentration of hydrogen ions in the salt marshes, considered as a biological factor.—**M. Bezssonoff**: The effect on guinea-pigs of an antiscorbic preparation.

## SYDNEY.

**Linnean Society of New South Wales, August 30.**—**G. F. Hill**: A new species of Mordellistena (Coleoptera, Mordellidæ) parasitic on termites. Description of a new species from Palm Island, N. Queensland, distinguished from all other Australian species of the genus by its large size and bright red prothorax. It is improbable that this parasite, of which the only known host is *Calotermes* (*Glyptotermes*) *nigrolabrum* Hill, could become a factor in controlling injurious species of termites.—**W. W. Froggatt**: Description of a new *Phasma* belonging to the genus *Extatosoma*. A female obtained at Gosford, N.S.W., differing from *Extatosoma tiaratum* W. S. Macleay, in its much more slender form, many more spines, different flanges on abdomen, and shape of legs.—**W. A. Haswell**: On *Astacocroton*, a new type of acarid. It is a parasite of the common spiny crayfish (*Astacopsis serratus*) of the rivers of New South Wales. It lives permanently in the gill-cavities of its host, and the mature females become permanently attached to the gills and incapable of active locomotion. The

food consists solely of the blood of the crayfish. In structure *Astacocroton* is related to the hydrachnids, but shows certain special features, particularly in the female reproductive apparatus.—**Vera Irwin-Smith**: A new nematode parasite of a lizard. It possesses an asymmetrical row of spines down one side. Nothing like it has been found previously in reptiles. It is assigned, provisionally, to the genus *Rictularia*, a genus recorded, hitherto, only from mammals. Only two females have been found.—**A. J. Turner**: Revision of Australian Lepidoptera: Saturniadae, Bombycidae, Eupterotidae, Notodontidae. Of the first three families only fifteen Australian species are at present known. The fourth family, the Notodontidae, is enlarged by the inclusion as a subfamily of the *Cnethocampinae*, a small natural group of which the European Procession Moth is the type. Nearly seventy Australian species are recognised.

September 27.—**Mr. J. J. Fletcher**, vice-president, in the chair.—**T. Steel**: Chemical notes: General. Some curious ferruginous concretions surrounding twigs, leaves, and fruit of *Hakea*, from a chalybite pool near Fitzroy Falls, N.S.W., are described and figured, and an analysis given; also stalagmite from a grotto at Wentworth Falls, having a similar composition. Analyses are given of cubical pseudomorphs of pyrites, from Western Australia, called locally "Devils' Dice"; of lime prepared by the Fijians from coral and used for plastering the hair; of the shells of *Helix aspera*, the urinary secretion of birds and reptiles, the fruit of the banana, and milk of unripe coconuts.—**Margaret H. O'Dwyer**: A note on protein precipitation in grasses. Stützer's reagent (copper hydroxide), tannin salt solution, Barnstein's reagent (a variation of the copper hydroxide method) and alcohol (85 per cent.) were used as precipitants. Tannin salt solution and alcohol appear to give the best results.—**Margaret H. O'Dwyer**: Further report on the nutritive value of certain Australian grasses. Analyses are given of grasses at the early flowering period and when the seed is set. The protein present decreases with the age of the grass, while crude fibre is higher in the older stages. Diseased grasses showed slight divergences from normal.—**W. F. Blakely**: The Loranthaceae of Australia (contd.), Pt. iii. Eight species and five varieties of the subgenus *Euloranthus*, of which one species and three varieties are new, are described.—**M. B. Welch**: The occurrence of oil-glands in the barks of certain Eucalypts. Oil-glands occur in the secondary bast of certain species of *Eucalyptus* (stems and roots). The contents of the secretory cavities become resinous and insoluble towards the outside of the bark. The function of the glands is probably protective.

**Royal Society of New South Wales, October 4.**—**Mr. C. A. Sussmilch**, president, in the chair.—**H. G. Smith**: On the occurrence of levo-*phellandrene* in the oil of *Melaleuca acuminata*. The species occurs in South Australia and is locally known in Kangaroo Island as "Lavender bush." The yield of oil is about 2 per cent., and this consists principally of *phellandrene* and *cincol*, the latter to the extent of 44 per cent.—**A. R. Penfold**: The essential oils of two varieties of *Leptospermum flavescens*. The northern form of this species, *var. microphyllum*, was obtained from Frazier Island, and the other new variety, called *leptophyllum* (Cheel), from Narrabri. Both oils consist essentially of alpha and beta pinene, sesquiterpenes, and sesquiterpene alcohols, with small amounts of *cincol*; *terpineol* is present in the latter oil.

## Official Publications Received.

- Proceedings of the Cambridge Philosophical Society. Vol. 21. Part 3 (Easter Term, 1922). Pp. 129-296. (Cambridge: At the University Press.) 7s. 6d. net.
- Proceedings, Asiatic Society of Bengal. (New Series.) Vol. 17, 1921, No. 1; Proceedings of the Eighth Indian Science Congress. Pp. xviii-cxxviii. (Calcutta: 1921.)
- Observations made at the Royal Magnetical and Meteorological Observatory at Batavia. Vol. 40, 1917, containing Meteorological and Magnetical Observations made in 1917. Pp. xx-106. (Batavia.)
- Records of the Indian Museum. Vol. 21. Catalogue of the Planorhida in the Indian Museum (Natural History). Calcutta. Part 2. By Louis Germain. Pp. 81-128. (Calcutta: Zoological Survey.) 2 rupees.
- Uganda Protectorate. Annual Report of the Department of Agriculture for the Year ended 31st December 1921. Pp. 87. (Entebbe.)

## Diary of Societies.

MONDAY, DECEMBER 4.

- VICTORIA INSTITUTE (at Central Buildings, Westminster), at 4.30.—Rev. C. Gardner: Romance and Mysticism.
- ROYAL ASTRONOMICAL SOCIETY (at Geological Discussion), at 5.—Twenty-one Minute Period in Earthquakes. Chairman: Prof. H. M. Macdonald. Speakers: Prof. H. H. Turner; Dr. J. H. Jeans.
- ROYAL INSTITUTION OF GREAT BRITAIN, at 5.—General Meeting.
- SOCIETY OF ENGINEERS, (at Geological Society), at 5.30.—W. Dinwoodie: Wave-Power Transmission.
- INSTITUTION OF ELECTRICAL ENGINEERS (Informal Meeting), at 7.—F. A. Sclater, and others: Discussion on an Electrical Installation at a Model Farm.
- AMATEUR SOCIETY (at University of London Club), at 8.—G. Cator: The One and the Many.
- ROYAL SOCIETY OF ARTS, at 8.—Prof. W. A. Bone: Brown Coal and Lignites (Cantor Lecture).
- SOCIETY OF CHEMICAL INDUSTRY (London Section) (at Engineers' Club, 39 Coventry Street), at 8.—Dr. G. S. Robertson and F. Dickinson: The Valuation of Insoluble Phosphate by Means of a Modified Citric Acid Test.
- ROYAL SOCIETY OF MEDICINE (Tropical Diseases and Parasitology Section) (Informal Meeting), at 8.30.—Prof. T. Leiper: Kinematograph Film of British Guiana: Its People, Natural History, and Scenery.

TUESDAY, DECEMBER 5.

- ROYAL SOCIETY OF ARTS (Dominions and Colonies Section), at 4.30.—Major O. Rutter: North Borneo.
- ROYAL SOCIETY OF MEDICINE (Orthopaedics Section), at 5.30.—H. A. T. Fairbank and others: Discussion on the Operative Treatment of Dislocation of the Hip, Congenital and Pathological.
- INSTITUTION OF CIVIL ENGINEERS, at 6.
- BRITISH PSYCHOLOGICAL SOCIETY (Annual General Meeting) (at London Day Training College), at 5.30; at 6.—Dr. E. O. Lewis: The Memory of Feeble-minded Children.
- INSTITUTE OF MARINE ENGINEERS, INC., at 6.30.—A. J. Brown: Marine Diesel Engines.
- ROYAL PHOTOGRAPHIC SOCIETY OF GREAT BRITAIN, at 7.—C. L. Hind: The Lesson of Photography.
- ROYAL ANTHROPOLOGICAL INSTITUTE, at 8.15.—Miss E. Kemp: The Aborigines of Western China.
- ROYAL SOCIETY OF INSTITUTION OF ELECTRICAL ENGINEERS, at 8.15.
- ROYAL SOCIETY OF MEDICINE (Pathology Section) (at St. Mary's Hospital), at 8.30.—Sir Albroth Wright: Immunisation *In Vitro*.—Dr. J. Freeman: Protein Sensitisation Experiments.—C. G. Schomborn: Interfraction.—A. F. Hayden: Classification of Acne Bacilli.—Dr. A. L. Punch: Tubercle Complement Fixation with Cow's Serum.—Dr. A. Fleming, C. B. Dyson, and V. D. Allison: Anti-bacterial Properties of Egg White.—W. D. Newcomb and Dr. J. M. Ross: Demonstration of Pathological Specimens.

WEDNESDAY, DECEMBER 6.

- GEOLOGICAL SOCIETY OF LONDON, at 5.30.—H. A. Baker: Final Report on Geological Investigations in the Falkland Islands. Prof. A. C. Seward and J. Walton: Fossil Plants from the Falkland Islands.
- ROYAL SOCIETY OF MEDICINE (Surgery Section), at 5.30.—The President and others: Discussion on Mistakes in Diagnosis and Treatment and the Lessons to be Learnt from Them.
- INSTITUTION OF ELECTRICAL ENGINEERS (Wireless Section), at 6.—E. B. Moullin: A Direct-Reading Thermionic Voltmeter, and its Applications.
- WOMEN'S ENGINEERING SOCIETY (at 26 George Street, Hanover Square), at 6.15.—E. S. Andrews: Patent Work for Women.
- SOCIETY OF PUBLIC ANALYSIS AND OTHER ANALYTICAL CHEMISTS (at Chemical Society), at 8.—E. W. Blair and T. S. Wheeler: A Note on the Estimation of Formic and Acet-aldehydes.—C. H. D. Clark: A Sinking Scale for the Convenient Titration of Strong Liquids by Dilution and Use with Alkalot Pairs.—H. A. Pearce: Note on the Presence of Sulphur Dioxide in Cattle Foodstuffs after Fumigation.—D. W. Stewart: Some Observations with regard to the Unassailable Matter and Sterols of Edible Fats.—N. Evers and J. Foster: Note on the Sulphuric Acid Test for Fish Liver Oils.
- ROYAL SOCIETY OF ARTS, at 8.—H. E. Chubb: Recent Developments in the Manufacture of Safes and Strong Rooms.

THURSDAY, DECEMBER 7.

- ROYAL SOCIETY AT 4.30.—*Probable Papers*.—Lord Rayleigh: Spectrum of Active Nitrogen as affected by Admixture of the Inert Gases.—

- Dr. G. H. Henderson: Changes in the Charge of an Particle passing through Matter.—W. T. Astbury: The Crystalline Structure and Properties of Tartaric Acid.—J. N. Mukherjee: Sources of Error in the Measurement of the Electrical Charge of Colloidal Particles by the Method of Moving Boundaries. An improved Method based on a Direct Measurement of the Potential Gradient across the Boundary.—J. Heyrovsky: The Significance of the Electrode Potential.—A. M. Mosharrafa: On the Quantum Theory of the Simple Zeeman Effect.—Dr. S. Brodetsky: Discontinuous Fluid Motion past Circular and Elliptic Cylinders.
- ROYAL AERONAUTICAL SOCIETY (at Royal Society of Arts), at 5.30.—Prof. C. F. Jenkin: Fatigue in Metals.
- INSTITUTION OF ELECTRICAL ENGINEERS, at 6.—A. M. Taylor: The Possibilities of Transmission by Underground Cables at 100,000/150,000 volts.
- CHEMICAL SOCIETY, at 8.—S. O. Rawling and W. Clark: The Isoelectric Condition of Gelatin.—H. J. S. Sand, E. J. Weeks, and S. W. Worrell: Studies on Metal Hydrides. The Electrolytic Formation of Sulphide in Sulphuric Acid and Cautic Soda Solution.
- ROYAL SOCIETY OF MEDICINE (Obstetrics and Gynaecology, Therapeutics and Pharmacology Sections), at 8.—Dr. H. H. Dale: The Value of Ergot in Obstetrical and Gynaecological Practice, with Special Reference to its Present Position in the British Pharmacopoeia. To be followed by a discussion.
- CAMERA CLUB, at 8.15.—B. Cox: Landscape—a Pot-pourri.

FRIDAY, DECEMBER 8.

- ROYAL ASTRONOMICAL SOCIETY, at 5.
- ROYAL COLLEGE OF SURGEONS OF ENGLAND, at 5.—Sir William Thorburn: The Surgery of the Spinal Cord (Bradshaw Lecture).
- ROYAL SOCIETY OF MEDICINE (Clinical Section), at 5.30.—J. E. H. Roberts: Thrombo-angiitis obliterans.—Dr. G. Evans: Thrombo-angiitis obliterans.
- MALACOLOGICAL SOCIETY OF LONDON (at Linnean Society), at 6.
- JUNIOR INSTITUTION OF ENGINEERS, at 7.30.—J. Ward: The Michell Thrust Bearing.
- PHYSICAL SOCIETY OF LONDON (at Imperial College of Science and Technology), at 5.—G. Shearer: The Relation between Molecular and Crystal Symmetry as shown by X-Ray Crystal Analysis.—Dr. E. A. Owen and G. J. Sturton: Modification of the Powder Method of determining the Structure of Metal Crystals.—Dr. A. B. Wood: The Cathode Ray Oscillograph.—A Demonstration of a low-voltage Oscillograph will be given by the Western Electric Company.
- INSTITUTION OF HEATING AND VENTILATING ENGINEERS, INC. (at Engineers' Club, Coventry Street), at 7.—Prof. A. H. Barker: Centrifugal Pumps as Applied to Heating Installations.
- INSTITUTION OF MECHANICAL ENGINEERS (Informal Meeting), at 7.
- ROYAL PHOTOGRAPHIC SOCIETY OF GREAT BRITAIN, at 8.—C. P. Crowther: The Making Behind the Camera and the Making of Portraits.
- ROYAL SOCIETY OF MEDICINE (Ophthalmology Section), at 8.30.—Continuation of discussion on the Significance of Vascular and other Changes in the Retina in Arterio-sclerosis and Renal Disease.

## PUBLIC LECTURES.

SATURDAY, DECEMBER 2.

- HORNIMAN MUSEUM (Forest Hill), at 3.30.—Dr. E. Marion Delf: Vitamins and Health.

MONDAY, DECEMBER 4.

- ROYAL INSTITUTE OF PUBLIC HEALTH, at 5.—Prof. T. Madsen: Antitoxic Treatment (Harben Lecture).
- CITY OF LONDON Y.M.C.A. (186 Aldersgate Street), at 6.—Gen. W. W. Ogilvy Beveridge: The Physique of the Nation.

TUESDAY, DECEMBER 5.

- ROYAL INSTITUTE OF PUBLIC HEALTH, at 5.—Prof. T. Madsen: The Influence of Temperature on Antigen and Anti-bodies (Harben Lecture).
- UNIVERSITY COLLEGE, at 5.15.—A. J. Davis: The Principles of Architectural Planning.

WEDNESDAY, DECEMBER 6.

- UNIVERSITY COLLEGE, at 5.30.—T. G. Hill: Illustrations of Books. Succeeding Lecture on December 13.

THURSDAY, DECEMBER 7.

- BARNES HALL, ROYAL SOCIETY OF MEDICINE, at 5.15.—Sir Arthur Newsholme: Relative Values in Public Health (Chadwick Lecture). (1) Value of Vital Statistics, Sanitary Surveys and Professional and Popular Education. Historical Influence of General Sanitation, Specific Sanitation and Combustion Action.
- CITY OF LONDON Y.M.C.A. (186 Aldersgate Street), at 6.—Prof. H. C. H. Carpenter: What Metals Look Like Inside.
- CENTRAL LIBRARY, FULHAM, at 8.—Prof. C. N. Bromhead: A Geologist's History of London.

FRIDAY, DECEMBER 8.

- LEATHERSELLERS' HALL (St. Helen's Place), at 2.15.—Prof. G. H. Carpenter: The Warble Fly: Its History, and Methods of Exterminating it.
- UNIVERSITY COLLEGE, at 5.15.—Sir William H. Beveridge: The Civil Service.
- BEITON HALL FOR WOMEN, at 5.30.—Prof. H. E. Butler: Timgad: The North African Pompeii.

SATURDAY, DECEMBER 9.

- HORNIMAN MUSEUM (Forest Hill), at 3.30.—Miss M. A. Murray: Ancient Egypt and the Bible.

# NATURE

A WEEKLY ILLUSTRATED JOURNAL OF SCIENCE.

*"To the solid ground  
Of Nature trusts the mind which builds for aye."*—WORDSWORTH.

No. 2771, VOL. 110]

SATURDAY, DECEMBER 9, 1922

{PRICE ONE SHILLING

Registered as a Newspaper at the General Post Office.)

{All Rights Reserved.

## BALANCES & WEIGHTS

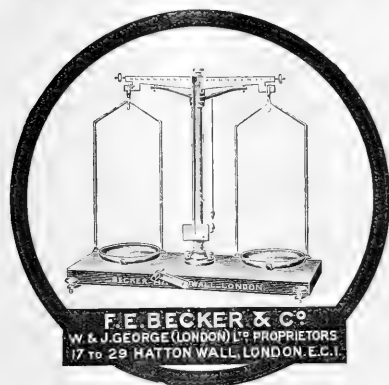

## REYNOLDS & BRANSON, LTD.

Chemical Glassware, Chemical and Physical Apparatus Makers to His Majesty's Government (Home and Overseas Dominions), Laboratory Outfitters, &c.

Gold Medals at Allahabad and London. Grand Prix and Gold Medal at the International Exhibition, Turin.

### STROUD & RENDELL SCIENCE LANTERN.

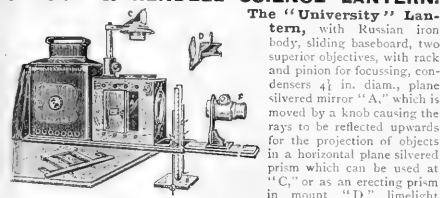

#### PRICE ON APPLICATION.

Wireless Apparatus and Accessories supplied.

CATALOGUES (Post Free).

Optical Lanterns and Accessory Apparatus. Chemical Apparatus and Chemicals (New Edition), etc., etc.

14 COMMERCIAL STREET, LEEDS.

## SPECTROMETERS

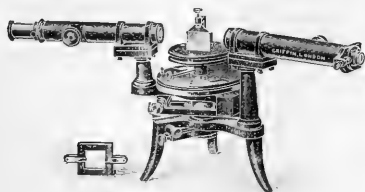

Particulars and Prices on application to—

JOHN J. GRIFFIN & SONS, LTD.

Kemble Street, Kingsway,  
London, W.C.2.



The Weather Watch is an ideal Christmas Gift. It forecasts the weather for the coming 12 hours.

In case

£7 10 0

NEGRETTI & ZAMBRA  
38, HOLBORN VIADUCT, E.C.1.  
LONDON.

**SWINEY LECTURES ON GEOLOGY,**

1922-23.

Under the direction of the TRUSTEES of the BRITISH MUSEUM.

A course of twelve lectures on "FOSSILS AND WHAT THEY TEACH" will be delivered by Professor T. J. JEHU, M.D., F.R.S.E., in the Lecture Theatre of the Imperial College of Science (Royal College of Science, Old Buildings), Exhibition Road, South Kensington, on Tuesdays, Thursdays, and Fridays, at 5.30 p.m., beginning Tuesday, December 12, 1922, and ending Friday, January 12, 1923. The lectures will be illustrated by Lantern Slides. ADMISSION FREE.

British Museum (Natural History),  
Cromwell Road, London, S.W.7.

**BATTERSEA POLYTECHNIC.**

LONDON, S.W.11.

Principal—ROBERT H. PICKARD, D.Sc., F.R.S.

Full-time day courses in Engineering (Mechanical, Civil and Electrical), Chemistry, Flour Milling, Physics, Mathematics.

Students prepared for University of London Internal Degrees, A.I.C. Examination, and Polytechnic Diplomas.

Evening courses in Engineering, Chemistry, Physics, Mathematics, and Music in preparation for Internal Degrees in the Faculties of Science, Engineering and Music.

Library, Writing Room, Common Rooms, Refreshment Rooms, Large Athletic Ground, etc.

Particulars on application to the PRINCIPAL.

**ROYAL HOLLOWAY COLLEGE**

(UNIVERSITY OF LONDON).

The LENT TERM commences on Saturday, January 13, 1923. The College prepares Women Students for the London Degrees in Science and Arts. Nine Entrance Scholarships, from £50 to £100 a year, and several Bursaries of not more than £35, tenable for three years, will be offered for competition in April 1923.

For further particulars apply to the SECRETARY, Royal Holloway College, Englefield Green, Surrey.

**UNIVERSITY OF BRISTOL.**

The UNIVERSITY invites applications for the CHAIR of PHILOSOPHY, which will be vacant on July 31, 1923. Salary, £800 per annum.

Applications should be lodged, on or before February 3, 1923, with the REGISTRAR, from whom further particulars are obtainable.

**UNIVERSITY COLLEGE, LONDON.**

ASSISTANT LECTURER IN PHYSICAL CHEMISTRY.

Applications, accompanied by testimonials, record of degree or degrees obtained, published work, and teaching experience (if any), are invited for the above post. Salary £300 per annum. Physicists who possess a knowledge of Chemistry, as well as Chemists, are eligible for the post. Applications to be sent as soon as possible, and not later than December 20, to the undersigned, from whom further particulars can be obtained.

WALTER W. SETON,  
Secretary.

University College, London,  
Gower Street, W.C.1.

**HARPER ADAMS AGRICULTURAL COLLEGE.**

NEWPORT, SALOP.

Applications are invited for the post of ADVISORY MYCOLOGIST. Particulars of the appointment may be obtained on application to the PRINCIPAL, to whom all applications, together with copies of three recent testimonials, should be addressed not later than December 18, 1922.

**CHELSEA POLYTECHNIC,**

CHELSEA, S.W.3.

Day and Evening Courses in Science under Recognised Teachers of London University.

- I. **INDUSTRIAL CHEMISTRY DEPARTMENT.**  
Technical Courses in Analytical and Manufacturing Chemistry, Pharmacy, Food and Drugs, A.I.C. Courses, Metallurgy, Assaying, Foundry Work, Research.
- II. **INDUSTRIAL PHYSICS DEPARTMENT.**  
Practical work in General Physics, Applications to Industries, Metrology, Calorimetry, Illumination, Acoustics, Electrical Measurement, Research.
- III. **BIOLOGICAL AND GEOLOGICAL DEPARTMENT.**  
Courses for B.Sc., etc., in Botany, Geology, Mineralogy, Zoology, Special Courses in Bio-chemistry, Bio-physics, Bacteriology, Physiological Hygiene, Entomology, Plant Pathology. Course for Tropical Planters, Research.

Leant Term begins January 9, 1923.

Telephone: Kensington 899. SIDNEY SKINNER, M.A.,  
Principal.

**UNIVERSITY OF LEEDS.**

CHAIR OF CHEMISTRY.

The PROFESSORSHIP of CHEMISTRY in the University will fall vacant at the end of the present session upon the resignation of Professor SMITHells, F.R.S. A new appointment, taking effect on October 1, 1923, will be made in due course. The salary attached to this appointment will be £1200 a year. Further information may be obtained from the REGISTRAR, The University, Leeds.

**THE UNIVERSITY OF LEEDS.**

DEPARTMENT OF AGRICULTURE.

Applications are invited for the position of additional INSTRUCTOR in HORTICULTURE. Salary £250. Applications will be received up to December 20, 1922, and should be addressed to the REGISTRAR, The University, Leeds, from whom further particulars may be obtained.

**FOR SALE.**

Baker's D.P.H. No. 1 Microscope, Abbe condenser, iris dia., triple nose-piece,  $\frac{3}{4}$ ,  $\frac{1}{2}$  and oil imm.  $\frac{1}{2}$ , 2 and 4 oculars, in mahogany case. Watson's Holo's, objective 1"; Do.  $\frac{1}{8}$  oil imm.; Do. Holo's, ocular  $\times 21$ ; Do. universal condenser. Reichert No. 6 objective. Lamp in mahogany case. Fitting accessories in mahogany case. Quantity of books on the microscope and useful sundries. All as new. £50.

Seen by appointment—

S. DRAPER,

67 GREAT TITCHFIELD STREET, OXFORD CIRCUS, W.

Telephone—Museum 823.

**THE GENERAL DISCUSSIONS OF THE FARADAY SOCIETY.**

The SECRETARY will send on application the latest list of available REPRINTS.—10 Essex Street, London, W.C.2.

The Misses FARRAN  
10 Bell Yard, Temple Bar, W.C.2,  
HAVE CONSIDERABLE EXPERIENCE IN  
**COPYING SCIENTIFIC MS.**

AND ARE PREPARED TO  
UNDERTAKE ANY QUANTITY.

**JUST PUBLISHED—SIMPLIFIED**

STELLAR MAPS and ASPECTS of the NIGHT SKY, together with a companion volume of ASTRONOMICAL TABLES (relating to the Rising and Setting of Celestial Objects). By J. C. CLANCEY, I.S.O., F.R.A.S., etc. Price, Rs. 7 only. Apply to—Times of India Press, or THACKER and Co., BOMBAY.

**SPECIAL MICROSCOPICAL SLIDE:**

Radium. Perpetually giving off numerous flashes of intense light. Post free, 2s. 3d. DARLSTON, 31 Freer Road Birchfield, Birmingham.



SATURDAY, DECEMBER 9, 1922.

## CONTENTS.

	PAGE
A Suggested Royal Commission on Museums . . . . .	761
Meteorological Theory in Practice. By Sir Napier Shaw, F.R.S. . . . .	762
Parker and Haswell's "Zoology" . . . . .	765
Cancer and the Public. By A. E. B. . . . .	766
Empire Water-Power. By Dr. Brysson Cunningham . . . . .	767
Our Bookshelf . . . . .	767
Letters to the Editor:—	
Spectrum of the Night Sky.—The Right Hon. Lord Rayleigh, F.R.S. . . . .	769
Medical Education.—Sir G. Archdall Reid, K.B.E. . . . .	769
Divided Composite Eyes. (Illustrated).—A. Mallock, F.R.S. . . . .	770
Action of Cutting Tools. (With Diagram).—H. T. Rowell . . . . .	771
An Empire Patent.—Ernest E. Towler . . . . .	772
The Movement of the Positive After-image.—Dr. F. W. Edridge-Green . . . . .	772
Acoustic Research.—Prof. Theodore Lyman . . . . .	773
Separation of the Isotopes of Zinc.—Alfred C. Egerton . . . . .	773
A Curious Feature in the Hardness of Metals.—Hugh O'Neill and Dr. F. C. Thompson . . . . .	773
The Use of a Pancreatic Extract in Diabetes. By Sir C. S. Sherrington, G.B.E., P.R.S. . . . .	774
The West Indian College of Tropical Agriculture. By Prof. J. B. Farmer, F.R.S. . . . .	775
The Flow of Steels at a Low Red Heat . . . . .	776
The Manufacture of Acids during the War. By Prof. T. M. Lowry, F.R.S. . . . .	777
Prof. Max Weber—CELEBRATION OF 70TH BIRTHDAY Obituary:—	780
H. J. Elwes, F.R.S. . . . .	780
J. H. Gurney. By W. E. C. . . . .	781
Current Topics and Events . . . . .	782
Our Astronomical Column . . . . .	785
Research Items . . . . .	786
The Royal Society Anniversary Meeting . . . . .	787
Live Specimens of Spirula. (Illustrated).—By Dr. Johs. Schmidt . . . . .	788
Solar Radiation at Helwan Observatory . . . . .	790
Natural Gas Gasoline. By H. B. Milner . . . . .	791
The Teaching of Physics to Engineering Students . . . . .	792
University and Educational Intelligence . . . . .	792
Calendar of Industrial Pioneers . . . . .	793
Societies and Academies . . . . .	794
Official Publications Received . . . . .	796
Diary of Societies . . . . .	796

Editorial and Publishing Offices:

MACMILLAN &amp; CO., LTD.,

ST. MARTIN'S STREET, LONDON, W.C.2.

Advertisements and business letters should be addressed to the Publishers.

Editorial communications to the Editor.

Telegraphic Address: PHUSIS, LONDON.

Telephone Number: GERRARD 8830.

NO. 2771, VOL. 110]

## A Suggested Royal Commission on Museums.

FROM time to time there appear in NATURE and elsewhere notes and articles that afford conclusive evidence of the valuable work done by our museums in scholastic education, in aid of industry on its technical as well as its artistic side, in the prevention of plant, animal, and human disease, in the general spread of beauty, and in the advancement of learning. But the work that is done is sparsely scattered through a large number of museums, and the isolated examples serve rather to show what might be accomplished than to give us cause for self-gratulation. There are in the British Isles about a score of national museums (supported, that is, in large part by Imperial taxation) and probably more than 350 museums and galleries supported mainly by local contributions. It would be no great exaggeration to say that scarcely two of these establishments are maintained and governed in quite the same way. Like so many other of our institutions they have originated at haphazard and have just "grewed," generally by unorganised accretion. Consequently, while some have the desire and the means to be of use in one or other of the ways enumerated, more have the desire without the means, and many have neither the desire nor the means. In no case has a museum the power and the funds to make all that use of its treasures which could be made, and which its guiding spirits probably wish to see.

For some time past there have been efforts from various quarters to remedy the waste of material, waste of money, and waste of effort that are the consequences of overlapping, competition, lack of co-ordination, inappropriate administration, unequal distribution of funds, and all the other evils inherent in this disorder. The Ministry of Reconstruction tried to bring all the municipal museums, if no others, under the Board of Education, but the museums protested. An important committee of the British Association produced a valuable report on museums and education. Lord Sudeley by pegging away has induced the Government to pay for guide-lecturers in several of its museums, and has advocated with some success the sale of picture-postcards. The Museums Association, which represents the views of museum officials themselves, urges, among other reforms, that museum curators must be highly trained men and women of broad education, and recognises that the only way to get such people is to offer an adequate salary.

These movements are very well, but if we are to make the best use of our museums something larger is required. Mr. Bailey, in a paper read at the recent

conference of the Museums Association and now published in the *Museums Journal* (October 1922), supports Lord Sudeley in his demand for a Royal Commission. Mr. Bailey, who, as sometime secretary for the Circulation Collections at the Victoria and Albert Museum, knows the provincial museums on their art side better than most men, has no difficulty in making out a case for reform. He is particularly strong on the unjust and unequal incidence of the aid which, though diminished, is still given to local museums by the State through some of the national museums. The officers of the Government establishments, always so willing to help, would doubtless be glad to see the way made clearer for them. Mr. Bailey's criticism on these and other weaknesses is destructive. There are schemes enough in the air, and he does not add to them. He asks, and he has induced the Museums Association to ask, for a Royal Commission, so that any recommendations may ultimately be based on the fullest possible knowledge. We agree fully that there is need for reorganisation, and we believe that a large amount of reform might be effected without material increase of expenditure; indeed, some of the obviously desirable reforms would tend to economy. But, while we sympathise with the request of the museum folk for a Royal Commission, we fear that they are not now very likely to get it. The subject, indeed, deserves serious discussion and it would be well to have various proposals compared and investigated, so that when changes are effected they may be guided by a definite policy. Some inquiry, less expensive than that by a Royal Commission, might elicit the information and put forward an accepted ideal towards which all could work.

Any such inquiry should, however, approach the subject on the broadest possible lines. The resolution passed by the Museums Association asks for a "report upon the work of the museums of the United Kingdom in relation to industries and general culture." The importance of museums on the industrial side has been recognised by the Federation of British Industries in a recent report. "General culture" is an expression that may include much or little; presumably it is intended to comprise scholastic education. But there are the numerous activities of museums that aid the extension and application of knowledge in ways that do not seem to fall under these heads. Whatever their subject-matter, and whatever their immediate and distinctive aim, all museums work by the same method—the accumulation, preservation, and demonstration of concrete objects; they are guided by the same broad principles, and need the same kind of assistance. Though they may be co-ordinated with other social activities—industrial, educational, artistic, and the rest

—they must not be confused with them. Any inquiry therefore must deal with museums as such, in relation to all their multifarious aims and activities, and must seek to bring all into one harmonious collaboration for the common weal.

### Meteorological Theory in Practice.

- (1) *Weather Prediction by Numerical Process.* By Lewis F. Richardson. Pp. xii + 236. (Cambridge: At the University Press, 1922.) 30s. net.
- (2) *Forms whereon to Write the Numerical Calculations described in "Weather Prediction by Numerical Process."* By Lewis F. Richardson. 23 forms. (Cambridge: At the University Press, 1922.) 2s.

IN the book under notice Mr. L. F. Richardson presents to us a *magnum opus* on weather prediction. The numerical manipulation of the dynamics and physics of the atmosphere is its mainspring; but there is a fine display of other works of an intricate character. Its avowed object is nothing less than the calculation of future events in weather; and this by inserting numerical values in seven fundamental formulæ, which, taken together, embody the essential analysis of the sequence of weather. Three of the equations express the time-rate of change of the easterly, northerly, and vertical components of the momentum of the air; other three express the time-rate of change of its density, water-content, and heat-content respectively. The seventh is the characteristic gas-equation for air; it contains no differentials.

The whole history of the atmosphere is to be unrolled on computing by finite differences the changes in the elements in terms of the changes of four independent variables representing space of three dimensions and time. The formulæ all relate to an individual sample of air in a column at a single point; but the calculation has to say what will happen to the whole mass in the neighbourhood of every specified locality within the region of observation. Hence representative points are chosen for which the changes of the variables are to be computed at a sufficient number of levels to give a working idea of the changes in the weather. The points are grouped in a lattice or chess-board with each square 200 kilometres long, 3° of latitude broad, and 2 decibars of pressure thick: the whole atmosphere is thus treated as made up of 16,000 slab-units each weighing about half a billion tons. What we call weather is represented by the physical changes in the slabs. The standard time-interval over which uniformity of change is preserved is six hours. Observations of pressure and temperature are taken for the centres of the "red" slabs of the checker,



which lie in columns of five deep; observations of momentum at the centres of the "white." The changes in any one slab are computed with the aid of the known conditions of the surrounding slabs: hence the calculation for any arbitrary area is limited to the interior slabs, and the area amenable for computation diminishes with each step of the process. There is a great amount of original and ingenious scientific speculation and discussion in the description of the process.

Nearly a hundred separate algebraical symbols are employed. The author sketches a fancy picture of the process of computation going on for the weather of the whole world in a great theatre or forecast-factory in the form of a hollow globe. A spherical orchestra of computers calculates the future weather from the information supplied by 2000 stations under the direction of a conductor at the centre of the globe. In order to keep pace with the weather the orchestra would consist of 64,000 performers on the slide-rule or calculating machine; and even then, with a space unit of 200 kilometres, phenomena on the small scale, such as tornadoes or local thunderstorms, might be missed. Part of the appeal of the book is for a distribution of stations to be arranged so as to give the process of calculation a better chance than the existing distribution in Europe affords.

There are twelve chapters of very unequal length. Chapter I. is a brief summary of the contents of the book; Chapter II. is a simplified example of the method of calculation by finite differences which is to be used. This preliminary canter shows incidentally that a distribution of pressure according to an assumed geometrical law, and a universal geostrophic wind corresponding therewith, lead to the conclusion that a vast system of high pressure over the Eurasian continent, covering one half of the Northern hemisphere east of the meridian of Greenwich, would result in an increase of pressure over England, which lies on the margin. This result is regarded as axiomatically contrary to fact, because "cyclones" are known to pass eastward. We are therefore invited to conclude in passing that the geostrophic idea is inadequate. That is certainly a possibility but not the only one. Since the geostrophic idea is based upon our experience of natural distributions of pressure we might with equal justice conclude that the assumed geometrical distribution is a non-natural one. Or better still, we might say that Mr. Richardson's preliminary canter has given a rigorous dynamical explanation of what is meant by "an anticyclone resisting the advance of a cyclone," a very common statement of meteorological phenomena. The reviewer preserves in memory two natural pictures of an Atlantic cyclone kept at bay by

a current from the east and presenting an appearance grotesquely like a revolving ball balanced on a water-jet. A notable feature of our northern winter is a vast anticyclone over Asia which dominates the northern half of the eastern hemisphere like Mr. Richardson's pattern, although the distribution over the other quadrants of the globe is not at all like the pattern. As a matter of experience the anticyclone does frequently spread from the east over England. Our weather might not inaptly be described as a conflict between the effect which Mr. Richardson repudiates as contrary to experience and the eastward travel of cyclones which he regards as axiomatic. Not infrequently, the result of the conflict is that the cyclones, instead of going eastward over us, are headed off to the north along the Norwegian Sea—"which nobody can deny."

In view of our inadequate knowledge of the structure and circulation of the atmosphere caution in drawing conclusions is always desirable, and in this case specially so in the interests of justice, because the alleged failure of the geostrophic principle to anticipate the changes at the surface in Chapter II. reappears in Chapter VI. as the record of a previous conviction, and gets the prisoner another sentence for what is perhaps not his fault. Mathematicians in dealing with the elusive atmosphere are not infrequently inspired by Jabberwocky,

One two, one two, and through and through,  
The vorpal blade goes snickersnack;

but they ought to make sure that they get the right Jabberwock by the neck before "galumphing back" with his head.

Chapter III. reinforced by Chapter VII. explains a suitable organisation of what are called co-ordinate differences, the principles of the chess-board or lattice, Chapter IV., a very important one, occupies more than one-third of the whole book. It is devoted to the fundamental equations and the information which is necessary in order to assign numerical values for the variables. It takes the form of about thirty short essays on great subjects, such as the effects of eddy-motion, radiation, conduction of various kinds, the flow of heat to the air from the sea, or from the ground, or from vegetation, the smoothing of observations, and many others. Chapter V. deals with the evaluation of vertical velocity, a very vital subject. Chapter VI. deals with the special conditions for the stratosphere and its equations. Chapter VIII. reviews the numerical operations to be performed and gives the final preparation for Chapter IX., which provides a "full-dress rehearsal" of the process of computation. By its aid

the changes of pressure and temperature for a point near Munich and the changes of momentum at a point between Munich and Hamburg are calculated for the interval of six hours centred at 1910 May 20d. 7h. G.M.T. That day was chosen for displaying the method because a set of data for the surface and upper air was available in the publications of the Geophysical Institute of Leipzig issued by Professor V. Bjerknes. Although not quite adequate for the purpose it is an unusually full set.

The calculation occupied "the best part of six weeks" in a rest-billet in France. It included, however, the preparation of the forms which are now issued in blank for the use of others who may be attracted by the prospect of submitting the course of Nature to the process of numerical calculation. Every assistance is given by the forms and by suggestions for improving the accuracy, smoothing the data, and many other technical points of manipulation.

The trial specimen is not such a good example of the art of forecasting that it tempts the reader forthwith to become one of the great orchestra. The change of pressure at the surface works out at 145 millibars in six hours. Our barometers allow for a range of 100 millibars at most; and, as a matter of observation, the change in the region in question was less than a millibar: the wildest guess, therefore, at the change in this particular element would not have been wider of the mark than the laborious calculation of six weeks. Nor is that all. Many of the chapters end in parenthetical expressions of regret or of suggestions for improvement. There are also many supplementary paragraphs which indicate that when the author comes to make another edition, as he or some one else undoubtedly will, he will write somewhat differently. And the reader will not be sorry, for in many ways the book makes hard reading. It is full of mathematical reasoning, a good deal of which is conducted "by reference." The reader who wishes to follow it must have a very handsome library and a few step-ladders which Mr. Richardson does not provide.

A reviewer with less than the ordinary sufferance of his tribe might easily murmur: forecasting by numerical process seems so arduous and so disappointing in the first attempts that the result is a sense of warning rather than attraction. He might also wonder for whom the author is writing, and regard the book as a soliloquy on the scientific stage. The scenes are too mathematical for the ordinary meteorologist to take part in and too meteorological for the ordinary mathematician. But such complaint would be as misleading as the computed forecast. On the road to forecasting by numerical process nearly every physical and dynamical process of the atmosphere

has to be scrutinised and evaluated; the loss of view into the future from the first summit is compensated many times by the insight which one gets into the working of Nature on the way. For example, the author draws from the miss of his forecast the conclusion that the observations of velocity used are a real source of error. Whether that conclusion is true or not, its further consideration is of the greatest importance in view of the multiplicity of observations of winds in the upper air and of the difficulties which their interpretation presents.

The essential obstacle in the way of bringing the facts of weather into mutual co-ordination by recognised methods of dynamics and physics is that there are so many of them, so many elements, so many variables, so many causes of perturbation. Some meteorologists look for a general solution of the problem in the discovery of new physical laws, at present unthought of, that will make things clear. Yet, even when we revel in the proud consciousness of being familiar with all the ultimate dynamical and physical laws to which the atmosphere is subject, we may yet fail in an endeavour to relate the conditions of the moment to those of the past or to anticipate the future from the present by lack of method in the arrangement of the facts.

When we look back at the triumphs of calculation of the historic past we find always that the skilful calculator has substituted an ideal, upon which it is possible to operate, for the intractable reality. The late Lord Rayleigh made the general position clear in his first volume on "Sound," where he pointed out that in order to study sound as vibration we imagine the sounding body to be completely isolated, though, if it were so, there would be no sound. Mr. Richardson in his preface properly cites the Nautical Almanac as an alluring example of forecasting by numerical process. We are reminded of Plato's maxim, "We shall pursue astronomy with the help of problems just as we pursue geometry, but we shall let the heavenly bodies alone if it be our desire to become really acquainted with astronomy." Perhaps astronomers have been disposed to press this maxim to the extreme, yet we must admit that the Nautical Almanac owes much to the ellipse in substitution for the actual orbits of the heavenly bodies. It would perhaps be difficult to imagine anything more unreal than the latest ideal of the atom.

Hence we might argue that the first step in meteorological theory should be to group the facts in such a way as to replace the reality by a reasonable and workable ideal. That view underlies the work of Hildebrandsson and Teisserenc de Bort in "Les Bases de la météorologie dynamique," in which they

endeavoured to present the ascertained facts in a collected form in order to lead up to a working ideal, believing that premature analysis had always proved unfortunate. For two generations now the general ideal of our atmosphere has been that of a succession of travelling cyclonic vortices and anticyclonic areas. Hildebrandsson and Teisserenc de Bort provided a normal permanent circumpolar vortex in which travelling cyclones might be formed. But the ideal presented is still inexcusably vague and undeveloped: there is much to be done before we can say even what we ought to look for in a map if we wish to identify a vortex travelling under the normal conditions of the atmosphere and we are not yet ready to do justice to that ideal.

Prof. Bjerknes on the other hand has set out to prove that our maps can be simulated or stimulated by wave-motion on either side of a surface of discontinuity which separates equatorial air from polar air. Here we may note a tendency to follow another Greek maxim, this time of Aristotle, "for those things which escape the direct appreciation of our senses, we consider we have demonstrated them in a manner satisfactory to our reason when we have succeeded in making it clear that they are possible."

In "Weather Prediction by Numerical Process" Mr. Richardson follows a line of thought which differs widely from either of these. His main simplifications are to divide the atmosphere into his 16,000 slabs and to ignore perturbations which are on a smaller scale than a hundred miles. The rest is rigorous. The principle which lies at the bottom of his treatment of the subject is that the known laws of dynamics and physics as applied to the changes which take place are inexorable and are sufficient. The future can therefore be derived from the present by their application. They can be applied by the step by step method of finite differences with sufficient accuracy to obtain the general consequences of the present conditions. The illustration of the process is a most valuable contribution to meteorology and indicates a wholesome course of practical physics and dynamics of the atmosphere which may prove the basis of future teaching. Thus it will not only provide an acid test of meteorological theory but also be a valuable guide to the organisation of new meteorological observations.

Finally, perhaps the most important aspect of this contribution to meteorological literature is that a rigorous differential equation is not necessarily useless because it cannot be integrated algebraically. It opens the way to useful exercises less stupendous than calculating the weather, and indeed, whenever meteorology comes to be taught and learned, the book will be a rich quarry for the teacher and examiner.

NAPIER SHAW.

### Parker and Haswell's "Zoology."

*A Text-book of Zoology.* By the late Prof. T. J. Parker and Prof. W. A. Haswell. In Two Volumes. Third Edition. Vol. I., pp. xl+816. Vol. II., pp. xx+714. (London: Macmillan and Co., Ltd., 1921.) 50s. net.

WHEN a demand arises for a new edition of a general text-book on some branch of science, the problem before the editor is to decide whether the new wine of recent discovery will go with safety into the old bottle. The solution depends largely upon the adaptability of the original scheme. When the treatment has been dominated by one aspect of the subject-matter, or when the science has entered on a new transitional phase of discovery involving new points of view, the new wine requires a new bottle.

Parker and Haswell's "Text-book of Zoology" illustrates this difficulty. Its outlook on the great and varied theme of animal life is fixed on the static anatomical aspect, on the intensive analysis of individual structure, and on the grouping of animals in classes according to structure. So fascinating and so adaptable to educational discipline is this pursuit that the anatomical aspect is only too apt to dominate other and equally important methods and aspects of animal study. It is against this over-emphasis of descriptive anatomical detail that teachers of zoology have been protesting for many years, with the result that in practice there is a more balanced consideration of the dynamical as opposed to the static aspect of zoology.

In this respect the new "Parker and Haswell" is disappointing. The rigidity of its structure has prevented its editor from adapting the text of these two volumes to modern requirements, or from embodying more than a very small amount of the new matter and none of the new points of view that zoologists have discovered in the last twenty years. The chief revision is limited to three groups of Invertebrates—the Nematodes, Polyzoa, and Annelids—while the whole of the second volume—the Vertebrates and the philosophy of zoology—has, so far as can be readily ascertained, undergone little change.

Ungrateful as is the task of adverse criticism, it must be acknowledged that this revision has not gone far enough. In contrast to the vigorous handling of the Platyelminths and Annelids, the loose treatment of the Nematoda is very pronounced. The account of the life-history of the common *Ascaris* is both wrong and misleading, and the description and figure of the hook-worm are most inadequate. In fact, in regard to parasitology generally, one has but to compare the little book recently published by M. Caullery and

reviewed in this journal with the scattered references to various parasitic groups in the present text-book, to realise the inadequacy of the method to which Parker and Haswell are bound by the rigidity of their scheme. The medical and pathogenic significance of the Protozoa and the occurrence of soil-Protozoa deserve more than the passing mention given to them on p. 51, or than the reference in vol. 2, p. 617, "a terrestrial *Amœba* has been described." The treatment of fresh-water medusæ is also inadequate, and the structure of the common starfish (*Asterias*) should have been followed by an account of its development now that Dr. Gemmill's account is fully accessible. The account of the Vertebrata is in need of more fresh and vigorous handling, especially from the embryological point of view. For example, to state without comment that a bird has three pancreatic ducts, as is done here, is to miss a fine opportunity of showing the fertilising effect of embryological interpretation. In the chapter on zoological philosophy, the barest indication is given of developmental mechanics and of regeneration, but not of the new point of view raised by American work on *Drosophila*. The text-book remains, in fact, a useful and well-illustrated account of exemplary anatomy. What students want is a series of small monographs on special subjects. Zoology is too big a subject to be treated adequately in a single work.

### Cancer and the Public.

*New Growths and Cancer.* By Prof. S. B. Wolbach. (Harvard Health Talks.) Pp. 53. (Cambridge, Mass.: Harvard University Press; London: Oxford University Press, 1922.) 4s. 6d. net.

THE lay public nowadays is very much interested in having healthy bodies, and its will to give active co-operative help to the medical profession in achieving this ideal is one of the few features of the new post-war Jerusalem that does not find itself in ruins. Medicine has ceased to be a cult of priests practising some mystery beyond the understanding of common people, and the abandonment of a professional dress means, not so much a recognition that a soft hat and tweeds are more comfortable than a tall hat and black coat, as an open expression that medical men and the lay public are fellow-workers for the common good.

How much may be attained by intelligent and interested lay folk working jointly with doctors has been illustrated lately very clearly by the disappearance of summer diarrhœa and the general decrease in infantile mortality—results, not of the direct application of assured scientific knowledge to practical life,

but of the devotion of common-sense men and women in schools for mothers and similar organisations, which followed quickly enough on the conviction that it was shameful that a child should be ailing or should die. It has been said, too, that the problem of venereal diseases was solved the day that "syphilis" appeared in the headlines of a reputable daily paper. It is, indeed, clear that real progress in healthiness is as much a question of laymen as of doctors. William James says somewhere that a good deed can be perfect only if it is well received as well as well done; it is, indeed, to this co-operation of both parties that we must look for further advance.

The knowledge of "medical" matters already enjoyed by the public in general is very much greater than it was even a few years ago. It is obviously a project of high importance that it should be enlarged and extended, and this is the purpose of the "Harvard Health Talks" of which the present small volume is one. It deals with cancer and new growths, and in 53 pages presents a great deal of information. So excellent is the purpose, that it is with some regret that we find the performance disappointing. The book fails in the way that some other books of the same kind have failed. The author has not realised the abyss which separates his training and terminology from those of his audience, and has presented them with an abbreviated version of a set of lectures to professional students rather than a discourse starting from their point of view instead of from his own. With the heartiest appreciation of the intelligence of the inhabitants of Boston and Cambridge, it is difficult to believe that they will get a good start in understanding cancer from "the unit of structure of living matter is the cell" and the rest of the conventional paragraphs of dogmatic biology that form the opening chapter: it is useless as well as unnecessary to ask the educated man in the street to begin a new subject from a point of view and in a terminology which are as Greek or worse to him. The author has evidently never wondered how the man who sits next to him in the street-car would describe the facts if he knew them.

Technically, too, there is room for substantial difference of opinion. Pigmented congenital moles are certainly not universally accepted as examples of "embryonic rests," and the sentences on p. 35 attributing irritation of the bladder to the "embryos" of *Bilharzia* are misleading. The practical directions with which the lecture concludes are, however, admirable: do not bother about cancer being supposed to be hereditary, avoid irritations, consult a medical man at the first suspicion of anything amiss, and "never select a doctor that you would not accept as a friend."

A. E. B.

### Empire Water-Power.

*Water-Power in the British Empire. The Reports of the Water-Power Committee of the Conjoint Board of Scientific Societies.* Pp. ix+54. (London, Bombay, and Sydney: Constable and Co., Ltd., 1922.) 3s. 6d. net.

IT is just about twelve months since reference was made to the third and final Report of the Water-Power Committee of the Conjoint Board of Scientific Societies (NATURE, December 8, 1921, p. 457). In the little book before us the whole of the results of the investigations made by the committee, as set forth in the three successive reports, are embodied. This compact statement of the present position of the British Empire in regard to the development of its water-power resources will be welcome to all who are interested in the matter, either from a purely scientific or from a utilitarian and practical point of view. It represents the outcome of four years of valuable research work, carried on with unremitting activity by the committee under the capable direction of the chairman, Sir Dugald Clerk, and with the energetic and painstaking assistance of the secretary, Prof. A. H. Gibson.

Sir Dugald Clerk contributes to the volume a preface of a very thoughtful and stimulating character. He tells us that the 46 million people now living in the United Kingdom require an expenditure of energy of  $10\frac{1}{2}$  million horse-power for their support, and that while this supply of power is undoubtedly forthcoming, for the present, from our stock of coal, yet our reserves of natural fuel are bound to diminish, and in time to be depleted, so that we shall be obliged to fall back upon other agencies to make good the deficit. Taking the United Kingdom as a whole, there appears to be continuously available (24 hour period) a total of 1,350,000 horse-power, or if any great tidal scheme, such as that of the Severn, be included, perhaps a total of 1,750,000 horse-power. This is, of course, insufficient to replace the work done by means of coal-fired engines, but, at least, it would represent a very substantial saving in fuel.

On the other hand, this power is not all economically realisable, or rather the cost of obtaining the whole of it would be higher than is justified, as yet. In Scotland, however, some 183,000 horse-power is immediately feasible, at a cost appreciably less than that of coal-fired stations built and operated under existing conditions. Even in England and Wales, a large proportion of the quota is commercially obtainable. It is obviously a matter, then, of national concern to devise means for making use of these natural power supplies, which are running to waste,

if only for the purpose of supplementing the work which is at present done by our far from inexhaustible supplies of coal.

The report covers a wider field than Great Britain; it embraces the resources throughout the British Dominions, and its carefully compiled figures will be of considerable assistance to those whose interest lies in the promotion of water-power schemes at home or abroad.

BRYSSON CUNNINGHAM.

### Our Bookshelf.

*Modern Electrical Theory.* Supplementary Chapters. Chapter XV.: Series Spectra. By Dr. N. R. Campbell. (Cambridge Physical Series.) Pp. viii+110. (Cambridge: At the University Press, 1921.) 10s. 6d. net.

THE work now before us is one of the supplementary chapters to Dr. Campbell's book on modern electrical theory. This series of supplements is planned according to an idea which might well be used by the authors of other text-books on physics. It is unfortunate, however, that we are unable to commend the present book to those who, like the reviewer, welcomed the author's original work as a real and vital account of the subject. The book contains numerous errors which any practical spectroscopist would detect at once; and they reach their culminating point when the author, in a professedly complete list of the chemical elements the spectra of which form well-defined series, omits oxygen, sulphur, and selenium. The spectrum of oxygen is, almost in a classical sense, one of the most beautiful and ideal series arrangements known to every spectroscopist. It has not played a part in the application of the quantum theory as yet, which may provide the explanation of the circumstance that the author is unaware of this fact, as he shows more than once.

The genesis of this book is quite clear. The author has read Bohr's recent work on the "Correspondence Principle," and, like every other reader, has been very much attracted by it. He has also consulted all the Danish and German writings, and he gives a really excellent account of them in a very non-technical style. Dr. Campbell appears, however, to be unaware of the contribution of this country to the subject, and of the practical details of spectra. The second deficiency explains why all the facts of spectra which he gives correctly are those which foreign writers have quoted in support of the quantum theory. Following the usual assumption that all the significant work on the subject has been done abroad, anything written in English is mostly ignored or misquoted. It is difficult, indeed, to find an English name in the whole work. A treatise on any branch of this subject which never refers to the fundamental work of Jeans, dismisses that of Fowler with a casual mention of his least important contribution, credits Nicholson with a mere suggestion that the angular momentum in an atom might have discrete values, and finally never mentions W. Wilson, who anticipated Sommerfeld in the fundamental generalisation, while putting it on a

real dynamical basis, as Sommerfeld himself has admitted in his latest edition, excites both surprise and regret. Except from one point of view, the work is misleading and inaccurate in detail. What it does give is a condensed summary of foreign work, which is excellent if read at the same time as a compendium of the actual experimental facts of spectra.

*Air Ministry: Meteorological Office. The Weather Map. An Introduction to Modern Meteorology.* By Sir Napier Shaw. Fifth issue (reprint of fourth). (M.O. 2251.) Pp. 109 + 8 plates + 8 charts. (London: H.M. Stationery Office, 1921.) 1s. 3d. net.

It is not possible to overestimate the high value of this work. At the present time the demand for weather knowledge is very keen, the enthusiasm being stimulated by the wireless broadcasting of weather information. To appreciate fully the information received by wireless it is essential to be able to grip intelligently the scientific details involved. The work under review contains much general information on meteorology. The former edition was issued four years ago, and the earlier copies gave much assistance in the training of meteorological units in the army, so essential for many interests during the war.

The publication contains specimen weather maps, and the letterpress thoroughly explains their construction and the results which the maps provide. Weather systems and their movements are dealt with and explanations are given of the sequence of weather, the travel of the centres of disturbances, and the veering and backing of the wind. Recent research relative to the upper air is incorporated, and a thorough understanding can be secured of the distribution over the British Isles of cloud and rain consequent on the passage of a storm area across the country. Information is given as to averages and normals, and the numerous tables, diagrams, and maps in the latter half of the book are useful for reference. The cost of the earlier editions of the work was 4d., but the charge, 1s. 3d., for the present issue is exceedingly small, and the work should be obtained by all who would be meteorologists. C. H.

*Rocks and their Origins.* By Prof. Grenville A. J. Cole. (Cambridge Manuals of Science and Literature.) Second edition. Pp. viii + 175. (Cambridge: At the University Press, 1922.) 4s. net.

It speaks well for the discrimination of the readers of popular science that a new issue of this thoughtful introduction to the study of rocks should be called for. Prof. Cole is equally at home in tracing the history of the development of scientific theories and in describing the relation of scenery to the geological structures of the rocks that underlie it. He discusses without too much technical detail the origin of the different types of rocks of which the earth's crust is composed, and gives a very fair résumé of the controversies which have been waged on the subject, many of which are still as active as ever. There are a number of happily chosen illustrations of rock scenery, mostly reproduced from the author's own photographs. This little volume is honourably distinguished from others of a similar character by the clearness of its style and the

abundant references which will prove useful in directing the student's attention to scientific contributions that he might otherwise overlook. There are few of our geologists who have read so widely and to such good effect as Prof. Cole. J. W. E.

*Farm Book-Keeping: The Principles and Practice of Book-Keeping applied to Agriculture: for Agricultural Colleges, Extension Classes, Evening Classes, and Practical Farmers.* By John Kirkwood. Pp. 224. (Edinburgh: W. Green and Son, Ltd., 1922.) 6s. net.

ONE of the most noteworthy developments in the study of agriculture is the attention which is now paid to the economic aspects of farm working. Mr. Kirkwood's book (one of the Scottish Series of Junior Agricultural Text-books) is to be welcomed as a work which contributes to this development.

Part I. consists of nineteen concise chapters dealing with double-entry book-keeping in its application to farm management. Part II. sets forth a simple cash-book system for the benefit of those who may regard double-entry as a complicated system, and the author assures us that his simplified method of keeping accounts has stood the test of actual use.

With practical handbooks of this kind on the market there can be no excuse for the repetition of those blunders in farm management which are the accompaniment of a disregard for scientific study and a blind adherence to tradition.

*Coal-tar Colours in the Decorative Industries.* By A. Clarke. Pp. xiii + 166. (London: Constable and Co., Ltd., 1922.) 6s.

THE uses of coal-tar dyestuffs in lake-making, and in leather, fur, wood, paper, etc., colouring—*i.e.* those applications which are not covered in the ordinary treatises on fabric dyeing—are considered in Mr. Clarke's work. The treatment is, naturally, wholly technical, and very brief. A bibliography is given. To the expert the treatment will doubtless appeal, but to the ordinary scientific reader such sentences as the following indicate a language even more formidable than his own: "The level-dyeing acid dyestuffs do not exhaust well, but if they are topped with basic colours the backwaters are colourless." A glossary might have been added for the uninitiated.

*The Peoples of Europe.* By Prof. H. J. Fleure. Pp. 110. (London: Oxford University Press, 1922.) 2s. 6d. net.

It was no mean task to attempt an adequate sketch of European peoples in about a hundred pages, but Prof. Fleure has been fairly successful. His volume is opportune at a time when a sound scientific basis for the discussion of the complex problems of Europe is essential, and it is a happy illustration of the value of a geographical foundation in the study of political problems. The book contains not only a great amount of information but also a wealth of ideas, and is a genuine contribution to the vexed questions of the time. There are three sketch maps and a short but useful bibliography. The lack of an index is unfortunate.

R. N. R. B.

### Letters to the Editor.

[The Editor does not hold himself responsible for opinions expressed by his correspondents. Neither can he undertake to return, or to correspond with the writers of, rejected manuscripts intended for this or any other part of NATURE. No notice is taken of anonymous communications.]

#### Spectrum of the Night Sky.

I HAVE now succeeded in obtaining a spectrogram showing the general features of the spectrum of the night sky in the south of England, with the moon below the horizon. The exposure given was about 50 hours, beginning each night not earlier than 2½ hours after sunset, and closing about midnight. There appears, therefore, to be no possibility that sunlight or moonlight intervened.

The spectrum shows the bright yellow-green aurora line very strongly. There is a continuous spectrum corresponding in distribution to the solar spectrum, and showing the dark Fraunhofer lines H and K. These are perfectly definite. The exposure is not enough to show the other Fraunhofer lines definitely, and, in any case, the instrument used is only capable of showing a few of the strongest of them.

There is no trace on this plate of the nitrogen bands, which form so conspicuous a part of the spectrum of the polar aurora. From some exposures I have made in the neighbourhood of Newcastle, three degrees farther north, I believe that the negative bands of nitrogen are a normal feature of the night-sky spectrum there. But more work is required on this point.

RAYLEIGH.

Terling Place, Witham, Essex.

November 25.

#### Medical Education.

It is stated in NATURE (November 18, p. 683) that "The professional course has grown so full in the training of a medical student that it has become increasingly difficult to cover the ground and secure qualification in a reasonable time." It seems that chemistry and physics are to be placed outside the professional curriculum, but biology is to be retained. A knowledge of chemistry and physics is necessary to the doctor; and much of the recent advance in both medicine and surgery is due to discovery in these sciences. But can any one tell us of what utility, practical or intellectual, is the biology which medical students learn—facts about the classification of plants, the vascular system of the sea-urchin, the digestive system of the leech, the bones in the cod's head, and so on? No one is a better physician or surgeon for such knowledge; and, therefore, since it has no bearing on later study and practice, it is forgotten as soon as the prescribed examinations are passed.

For the medical man the intellectual value of biology should lie, if anywhere, in interpretation. It should cause him to think. He should learn man's place in Nature—how he resembles and differs from other living beings, and how these likenesses and differences arose. Man is in body and mind above all the educable, the trainable, the adaptive being. From birth forwards he develops mainly in response to use. He is rational and intellectual because his mind grows through functional activity. That is his special distinction; that places him in Nature. The medical student learns nothing of all this. He may be taught, incidentally as it were, that some characters are inborn, or acquired, or inheritable. But a year

or so later, physiologists and pathologists tell him the quite indisputable truth that every character takes origin in germinal potentiality (predisposition, diathesis), and arises in response to some sort of nurture—i.e. that every character is equally innate, acquired, and inheritable. If the student thinks at all, he must conclude, as Prof. Armstrong says very truly in another connexion (NATURE November 11, p. 648), "We are mouldering away in our laboratories and when we seek to make known what we have been doing we use a jargon which we cannot ourselves understand."

The medical student may be told that Natural Selection is an interesting speculation, but that no man has seen it in operation. Again, if he thinks, he will conclude that, owing to defective opportunities for observation, no man could see Natural Selection in operation among the wild animals and plants which biologists study. Nevertheless, a year or two later he will perceive it in full swing in the case of tuberculosis and every other lethal and prevalent human disease, and will learn that every human race is resistant to every human disease precisely in proportion to the length and severity of its past experience of that disease. There are scores of diseases and hundreds of races and sub-races of mankind; and, therefore, in some thousands of instances—whenever and wherever close observation is possible—he will find Natural Selection causing adaptive evolution. Moreover, he will learn that just as human races alter gradually in powers of resistance, so, at the other end of the scale, bacterial races alter in virulence when removed from one kind of animal to another, a thing quite inexplicable except on grounds of Natural Selection.

The student may be taught that effective selection occurs among mutations, not fluctuations. A year or so later he will perceive tuberculosis selecting amid all shades of difference, with the result that races present all shades of evolution. He may be taught that mutations segregate and that their inheritance is alternate. A year or so later he will learn that human mutations (e.g. idiocy, hare-lip, club-foot) are inherited, perhaps for many generations, in a patent or latent condition, and that only their reproduction is alternate. Moreover, he will wonder, if mutations segregate, how it happens that long-lost ancestral traits sometimes reappear in *purely bred* domesticated varieties (e.g. pigeon, poultry, and many plants). He may be taught that evolution depends on mutations and that mutations do not blend. A year or two later he will learn that human races never differentiate while there is inter-breeding, but diverge rapidly and infallibly when separated by time and space; that, though men are fond of telling about wonders, yet in the whole of written human history (4000 years or more) no useful human mutation has been recorded, nor one that changed the type of a race; that all human varieties (e.g. negro and white), like all natural varieties (e.g. brown and polar bear), blend perfectly when crossed in all characters except those linked with sex; and, lastly, that "lost" ancestral traits never reappear except when one of the parties to the cross is derived from a domesticated variety. If he thinks at all, he will conclude that Natural Selection is founded on fluctuations, but that man, as Darwin noted, "often begins his selection by some half-monstrous form, or at least by some modification prominent enough to catch the eye or to be plainly useful to him." He may be taught that the doctrine of recapitulation is doubtful. But if he thinks at all, he will perceive that any other mode of evolution and development is totally inconceivable. And so on.

The point I wish to emphasise is that medical men, with an acquaintance with man infinitely more

intimate than any biologist can have with any animals or plants, with abundance of direct, not merely circumstantial evidence, have no need for the traditional biology of biological teachers. They are in a position to construct, and for all practical purposes have already constructed, a biology of their own. The traditional teaching has with them no influence whatever except as a waste of time, and ought to be, and before long is sure to be, eliminated from a curriculum which has outgrown it.

G. ARCHDALL REID.

9 Victoria Road South, Southsea,  
November 19.

### Divided Composite Eyes.

It is not uncommon to find among insects instances where each composite eye is divided into two portions, so that in appearance there seem to be four eyes instead of two. In sections, however, it is seen that both parts are connected with the same ganglion.

Sometimes the reason for the division is obvious, as in the case of certain beetles which have a prominent sort of "armoured belt" carried horizontally round the head. Here half the eye is above and half below the belt, thus giving a view of the ground as well as of objects above it.

The reason for duplication, however, is not always so apparent. In the majority of composite eyes the convex surface is covered with lenses of uniform size, but in those to which the present note relates, namely, dragon-flies, White (or Cabbage) fly, and Aphides, this is not the case.

Among the dragon-flies—a very highly developed type—each eye presents a continuous convex surface, but the lenses of the upper part are much larger than those below. The transition from large to small is quite abrupt, but as the curvature of the surface is continuous the line of demarcation is not noticeable without the use of a magnifying glass.

In the White-fly (*Aleyrodes proletella*, etc.), where the eyes are well divided, the relative position of the large and small lenses is reversed, the large lenses being below.

The eyes of Aphides present for the greater part of their area a convex surface carrying lenses of equal diameter, but not far from the posterior margin there is a small prominence bearing a few lenses on its summit and sides.

The appearance of the eyes of dragon-flies is so well known that it is scarcely necessary to give figures, but it may be remarked that the areas covered respectively by the large and small lenses differ considerably both in form and extent in different genera.

White-fly is chiefly known as a pest in green-houses, and until its appearance in unusual numbers in the autumn of 1921, I had never given it any attention. Any one, however, who examined the perfect insect with a magnifying glass might well be excused for taking it (as did Linnaeus) for a small moth, but if the course of its development is followed up from the egg to the imago it is seen to be more nearly allied to the Aphides.

Far the best account of it is given by Reaumur ("Memoires," Tome II.) in 1736, and having myself repeated his observations of its transformations, I can confirm the accuracy of his description. All Reaumur's specimens were apparently taken from the leaves of *Chelidonium majus*, but this plant is not abundant in the neighbourhood of Exeter.

White-fly, however, feeds on a great variety of leaves, and I have taken it from cabbage, cucumber, tomato, campanula, veronica, and from many composites. There is a considerable difference in these cases both in the size of the perfect insects and in the density of the cottony down with which they are coated, which gives them their white appearance, but whether this implies real specific differences or is only a result of

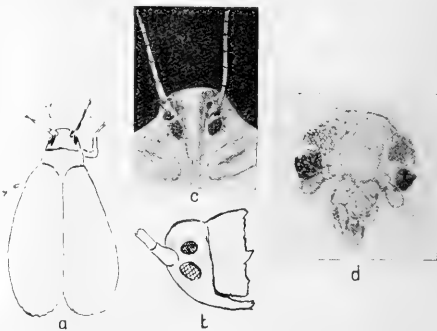

FIG. 1.—*Aleyrodes*.

a, Camera-lucida sketch of *A. proletella* × 25.

b, Head, side view.

c, Head, from below.

d, Head × 125 (60 in the reproduction), front view to show the difference in the size of the lenses in the two divisions of the eye. The contents of the head and the exterior down have been removed. The specimen was taken from cucumber. Diameter of upper lenses 0.0003 in., of lower lenses 0.0005 in.

different food, is, I believe, considered uncertain. Among my own specimens, those taken from cucumber were the smallest in size and had the thinnest coating of down. The divided eyes were closely similar in all, and the general appearance of the insect is shown in the camera-lucida sketches, Fig. 1. When the head is viewed from underneath, especially when it is so turned that only the lower pair of eyes is visible, the face is curiously owl-like, the proboscis standing for the beak.

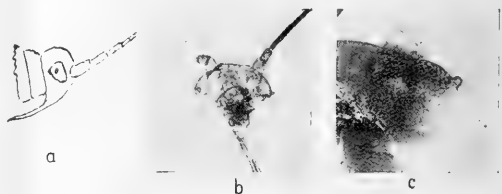

FIG. 2.—Black Aphis taken from Laburnum.

a, Head, side view.

b, Head, front view × 50.

c, Eye and part of head × 125 (60 in the reproduction), seen from above.

The eyes are shown in more detail in the photograph, Fig. 1.

There is always some difficulty in photographing such objects as require large magnification, but the structure of which does not permit of these being flattened; and though much less detail is shown in Fig. 1 c than can be made out by focussing each part independently, the difference in the size of the upper and lower groups of lenses is very apparent.

Several species of Aphis taken from various plants were examined, and in all of them the eyes had the



peculiar feature illustrated in Fig. 2, *a*, *b*, and *c*. The prominence varied slightly in size and position in the different species, but there was always at least one lens on the summit and three or four round the sides.

Divided eyes must be, or at some period have been, of use to their possessors. Have the naturalists any explanation of what that use is? The case of the *Aphis* eyes seems especially difficult.

In the last century Johannes Muller expressed the opinion that in the picture formed by a composite eye each lens contributed only one impression, *e.g.* that the picture was made up of only the same number of patches of light and shade as there were lenses to form them, just as in the modern "process block" light and shade effects are produced by the varying intensities of uniformly distributed dots.

In 1894 I gave (Proc. R.S.) some theoretical reasons in support of Muller's view. This paper has been mentioned in several more recent books, but the theory itself is not quoted. It is, however, so simple and, coupled with the measurements of various composite eyes, so conclusive that it may be worth repetition in this place.

Every one knows, or ought to know, that the image formed by a perfect lens of a distant bright point consists of a bright disc surrounded by faint rings, and that the angular diameter of the disc as seen from the optic centre of the lens is of the order  $\lambda/D$ ,  $\lambda$  and  $D$  being respectively the wave-length of the light and the diameter of the lens. This being the case, it is evident that no advantage in definition will be gained by providing a retina capable of distinguishing angular distances less than  $\lambda/D$ , *i.e.* the least distance which the lens can resolve.

If the wave-length is taken as  $1/50000$  of an inch, then for a lens 0.001 in. in diameter  $\lambda/D$  is rather more than one degree, and for a diameter of 0.001 in., rather more than ten degrees.

If a number of small lenses are placed side by side with their edges touching on the surface of a sphere of radius  $R$ , and if the focal length of the lenses is small compared to this radius, images of outside objects will be formed on a concentric spherical surface (with a radius somewhat less than  $R$ ); in these images, only those objects can be separated of which the angular distance apart is greater than  $\lambda/D$ .

If, then, the focal surface is covered by a retina which provides only one sensitive point for each lens to act on, the maximum definition will be secured if the subtense of each lens at the centre of the sphere is also  $\lambda/D$ , that is if  $D/R = \lambda/D$ , and this is the relation found to hold in the most highly developed composite eyes. It may be said, therefore, that the construction of these eyes is one of the most definite references to the wave-length of light to be found in organic structures. The actual values of  $D$  lie between something over 0.001 in. and a little less than 0.003 in.<sup>1</sup> The definition, therefore, even in the most favourable cases, is very poor compared with that given by the simple eyes of vertebrates, where a single lens forms an image on a retina closely packed with sensitive points, while in the composite eye each retinal point is capped with its own lens.

To form a composite eye with the same defining power as the human eye, for example, the lenses would have to lie on a spherical surface of 18 ft. radius.

It would be interesting to know how or why the two types have come into existence. A. MALLOCK.

9 Baring Crescent, Exeter, November 7.

<sup>1</sup> I have taken some trouble in arriving at this lower limit, measuring directly for this purpose the values of  $D$  for the smallest Diptera (and their parasitic Hymenoptera), Ephemera, and others.

### Action of Cutting Tools.

If Mr. Mallock's friction theory of cutting-tool action is valid, and if cutting tools are ever effectively lubricated, it would follow that the dry tool should have an angle different from that of the lubricated tool. But this is contrary to universal practice. The inference would then be that either the friction theory is unimportant and extremely incomplete, or that lubrication as practised by engineers is very ineffective. The latter view seems more correct, for the following reasons.

When a tool has been cutting for some time, metal accumulates on the point of the tool and adheres sometimes so firmly that it cannot be removed, without risk of breaking the tool, except by grinding. This agglomeration of metal may be said without looseness to be welded to the tool just as in cases of bearing seizure the metals are welded together. This is especially obvious in heavy work, and it can be seen in a lesser degree in moderately light work. When contact is so intimate and pressure so great as to cause such cohesion it is difficult to conceive that lubrication in the usual sense of the term can exist at the point of a cutting tool.

Moreover, engineers in many countries have striven to introduce lubricant to the cutting face by means of high-velocity jets and by drilling holes in the nose of the tools, but without success.

Lastly, the temperature at the tool face is extremely high. Turnings which pass over the surface are hot enough to cause serious burns, and large tool cross-sections are necessary to conduct the heat away from the nose of the tool. It has been observed that modern high-speed steel will cut at a dull red heat; and while this is an abnormal condition, there is evidence enough to show that the temperatures existing in average machining work are higher than can be met by special lubricating systems under less strenuous pressures. These considerations seem sufficient to rebut the idea of cutting-tool lubrication in most cases, and to suggest that the chief value of so-called cutting oils is in their cooling properties. Even turpentine, which is useful in cutting hard steel, may have much of its value in its latent heat of evaporation. Certainly to obtain a good finish on hard steel with turpentine often requires a spring tool and light cuts, in which case there is the equivalent of chatter in a mild form, and this is conducive to lubrication.

In the discussion on Prof. Coker's paper it was stated that the point of the tool was not in contact with the work, and Dr. Lanchester very trenchantly asked, What was the good of having the tool sharpened? But it is well known on heavy work or with tools of inferior temper that work must be stopped periodically and tools reground. The idea that the point of a tool is not in contact with the job is perhaps a natural one, and rests on a difficulty hitherto unexplained. It is common observation that a tool wears most some little distance from the edge, and the edge may last a good deal longer than the part behind it. But this is no proof that the edge is not in contact; and if the edge were not in contact, the action of cutting tools would be even more perplexing than it is.

The explanation of this point may lie in the fact that the turning has less relative motion near the edge of the tool than at some distance behind, and the justification for this view is seen in a closer examination of the motion of a turning. The neutral axis of a turning has a constant speed approximately equal to the cutting speed, but when the turning begins to bend there is a speed of rotation added to the speed of the neutral axis, and this rotational

speed varies as the thickness of the turning. As the turning does not begin to curl or bend until after it passes the edge, it is not difficult to see why the edge should wear well and give the impression that it had not been in contact. The fact that the point of the tool is in contact with the work may be inferred from the fact that in many circumstances steel is welded on to the point, and but for the greater relative motion behind the cutting edge where the scouring action is excessive, this deposition of metal would probably be more extensive.

We are then driven back on another part of the problem. Why do shavings curl? The analogy with rivet heads is unconvincing, for shavings are universally flat in a lateral direction, which—having regard to variety of tool profiles—is evidence of the extraordinary stresses involved and of the flow they produce—the stress on the upper face of the tool is of the order of 100 tons per square inch in quite ordinary practice. A more direct and convincing explanation is the following. Consider a piece of the shaving as in the diagram (Fig. 1). There is the downwards shearing force  $S$  at the principal plane of shear and an opposite reaction  $R$  at the tool face. These produce a turning couple which has more than one effect. In most cases the effect of this couple is

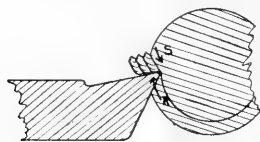

FIG. 1.

to distort the emerging element into a wedge the base of which is extended by plastic flow at the tool face and the upper part is shortened as in bending. The tendency is to place the lower or bearing surface of the shaving in tension as in a beam, and if the material has a low tensile strength as in cast iron, the shavings break, but even these brittle materials show a slight curl in the small particles removed by the tool. Friction at the tool face, as Mr. Mallock points out, resists curling, but it is probably not the governing factor. In the discussion on Prof. Coker's paper, Mr. H. I. Brackenbury put forward the very important observation that slow speeds are conducive to curling and high speeds produce straight shavings—this in tough steel. Having regard to the fact that cutting-tool action is a problem in plastic flow, the viscosity of the metal is probably important; and as the temperatures at the moment of cutting are very high, conductivity and tensile strength when hot may be decisive factors. The ratio of shearing strength to tensile strength enters into the phenomenon of curling, but as parts of the shaving are flowing it is not easy to get clear views on what is taking place.

H. S. ROWELL,  
Director of Research.

Research Association of British Motor  
and Allied Manufacturers.

15 Bolton Road, Chiswick, W.4.  
November 9.

#### An Empire Patent.

MR. HULME'S letter in NATURE of November 11, p. 633, raises objections to the Empire Patent on grounds which would occupy too much space to traverse fully, but I would venture to question his general con-

demnation of the present patent system. A system such as he proposes, which would grant a monopoly only to such persons as were actually working an invention, would be unjust to an inventor without capital to exploit his ideas. Moreover, considerations of novelty could not entirely be left out. Presumably Mr. Hulme would leave this to be decided by the Courts; but litigation is costly, and I imagine that few concerned with the business side of patents would be willing to dispense with a search for novelty on the part of the Patent Office, the advantages of which appear to be sufficiently obvious. The limitation, for practical reasons, to British patent specifications does not detract from those advantages, for, assuming the patent system to be of some value, it is most likely that subject-matter of a patentable nature will be disclosed in the first place in a patent specification. Mr. Hulme's objections to the search appear to be based largely upon United States experience, but the opinion he quotes may be due to difference of efficiency in administration in the two countries, particularly when we consider that American search is theoretically not so limited as here.

The arrangements as to "working" laid down in the Patent Act of 1919, which ensure that any patent granted in this country must be worked here on a commercial scale, would, it is to be presumed, apply to an Empire Patent.

In conclusion, may I be allowed a word of warning on the too facile application of biological considerations to human society? Mr. Hulme's assumption that a flattening of the population curve is an unfavourable symptom would not be endorsed by sociologists, and tends to discount whatever force there may be in his biological deductions *re* Patent Laws.

ERNEST E. TOWLER.

35 St. Andrews Square,  
Surbiton, November 15.

#### The Movement of the Positive After-image.

THERE is no doubt that movement of the positive after-image takes place without movement of the eyes as Mr. H. S. Ryland states (NATURE, November 18, p. 668). His experiment is complicated by the fact that all portions of the light shown have not the same intensity, causing a corresponding difference in the after-image.

There appears to be, at any rate while the eyes are being used, a steady circulation of photo-chemical material from the periphery to the centre of the retina. The following experiment shows very simply the movement of the positive after-image without moving the eyes. If two rectangular strips of white paper about three inches long and a third of an inch wide be placed on a piece of black velvet and separated by a distance of an inch, definite positive after-images may be obtained of the two strips by viewing them with one eye, the eye being directed to a point midway between the two strips of paper, the other being closed and covered with black velvet, for the shortest possible time, the eye being simply opened and closed. Two clear-cut positive after-images will first be seen; these rapidly become blurred and gradually approach each other, the central portions of each appearing to bulge towards each other and to combine first; the upper and lower portions disappear first, the two after-images gradually combine in the centre of the field of vision, the last phase being a white circular blur, which slowly disappears with a whirlpool movement. It will be noticed that the after-images do not become negative. F. W. EDRIAGE-GREEN.

London, November 18.

### Acoustic Research.

THE editorial article on the subject of "Acoustic Research," in NATURE of October 28, p. 565, conveys an impression which seems to need correction.

In justice to the life-long labours of the late Prof. W. C. Sabine, now gathered into a volume of "Collected Papers on Acoustics" (Harvard University Press), it should be said that the practical problem of predicting the acoustics of an ordinary auditorium in advance of its construction, or of correcting one already built, was solved by Prof. Sabine some twenty years ago. The essential feature to be considered in such a problem is the reverberation, and Sabine's papers on this subject are full and complete. Other acoustic questions are, of course, sometimes involved, such as the transmission of sound through walls, the effect of resonance, etc. Several of these had also been the subject of prolonged experimental investigation by Prof. Sabine at the Jefferson Physical Laboratory at Harvard, but some of the results were withheld until the work could be completed. His untimely death interrupted this programme, and since then the work has been continued here, and at the Acoustical Laboratories, Illinois, under the direction of Dr. Paul E. Sabine, as described in Mr. Munby's article in the issue of NATURE of October 28, p. 575.

Architects in the United States have become aware of the importance of Sabine's results, and scores of cases could be cited in which the application of the principles worked out by him has led to complete success. The opinion that "the laws regulating the production of a successful building for hearing and speaking have yet to be worked out" implies a lack of respect for Sabine's profoundly accurate and thorough work, which I am sure no one will maintain who has taken the trouble to acquaint himself with the subject.

THEODORE LYMAN.

Harvard University, Cambridge, Mass.,  
November 14.

[The intention of the article to which Prof. Lyman refers was to promote increased attention to acoustic research; and we regret that a phrase in it should be regarded by him as implying a lack of respect for the pioneer work done by the late Prof. Sabine. While readily admitting the value and completeness of Prof. Sabine's papers, the continued useful activities of his acoustic laboratory would seem to indicate that in the general sense intended the expression used in reference to the need for further investigation was justified. It may be true that rules have been worked out upon which a perfect acoustic building can be constructed; the practical problem presented to the architect, however, often takes the form of the provision of acoustic success with prescribed limitation in the matter of design, and it is in this direction that further knowledge is needed.—EDITOR, NATURE.]

### Separation of the Isotopes of Zinc.

PURE zinc has been subjected to distillation in a high vacuum, and after three fractionations of the distillate the latter shows a lower density than the original zinc. The residue has been reduced by evaporation to one-twentieth of the original volume and shows an increased density. The method of separation is similar in principle to that of Brønsted and Hevesy for mercury.

Two sets of distillations have been carried out. In the preliminary set, last winter, the distillations of the distillate were carried out too rapidly and too great a quantity was distilled. The results for the distillate indicated no separation, whereas the separation of the residue, which was effected under better conditions, showed an increase in density.

Another set of distillations was therefore carried out this summer under improved conditions (using liquid air condensation and a more careful regulation of the temperature and the quantity distilled). The final distillate is lighter and the final residue heavier than the original zinc. The determination of the density of a metal, as ordinarily performed, is no criterion of the average atomic mass per unit volume. The main part of the work has therefore been directed towards making it so; the only alternative appears to be the determination of the atomic weight to an accuracy of about 1 part in 10,000. The presence of flaws, of impurities, of allotropes, and of metal in a different physical state do not sufficiently explain the results; the discussion of these four points will be included in the publication of the work.

Taking the density of the initial zinc as unity, the density of the distillate is 0.99971, and of the residue 1.00026. These numbers appear to be outside the error of 14 determinations of the density of 7 separate samples of the initial material, for the greatest divergence between the numbers obtained only amounts to 0.00015. On recasting the residue and the distillate the difference is maintained.

The separation indicated by these figures would imply a change in atomic weight of about  $3\frac{1}{2}$  units in the second place in the atomic weight. This is considerably less than might have been expected if the metal was composed of equal quantities of an isotope of an atomic weight of 64 on one hand, and of isotopes 66, 68, and 70 on the other hand.

ALFRED C. EGERTON.

The Clarendon Laboratory, Oxford,  
November 21.

### A Curious Feature in the Hardness of Metals.

By combining Meyer's formula

$$L = ad^n$$

with that for the ordinary Brinell test

$$H = L \div \frac{\pi D}{2} (D - \sqrt{D^2 - d^2})$$

the following relationship is obtained:

$$H = \frac{2}{\pi D} \cdot a^{\frac{2}{n}} \cdot L^{\left(\frac{n-2}{n}\right)} \left\{ D + \sqrt{D^2 - \left(\frac{L}{a}\right)^{\frac{2}{n}}} \right\}$$

In this the second term ceases to have a real meaning when

$$D = \left(\frac{L}{a}\right)^{\frac{1}{n}}$$

Beyond the load corresponding to a value

$$L = aD^n$$

the hardness becomes imaginary, or, in other words, the load will be sufficient to force the ball through the material continuously. This fact may well be of considerable importance in connexion with such questions as the penetration of a plate by a projectile, in punching operations, and even in lathe work.

In the case of a steel of 0.2 per cent. carbon and 0.6 per cent. manganese with a Brinell hardness number of 140, using a ball of 10 mm. diameter, and a load of 3000 kilograms, the values of  $a$  and  $n$  will be about 74 and 2.29 respectively. Under these conditions the load at which perforation of the steel will occur will be 14,400 kilograms, when the hardness will have fallen to 92.

Further work in this direction is being carried out by one of us; but the fact that there is a high load at which the ordinary hardness measurements cease to apply, and the possible significance of the fact, seemed sufficiently interesting to warrant early publication.

HUGH O'NEILL.  
F. C. THOMPSON.

The Victoria University of Manchester,  
November 15.

## The Use of a Pancreatic Extract in Diabetes.<sup>1</sup>

By Sir C. S. SHERRINGTON, G.B.E., P.R.S.

IN the words of its charter, repeated at the admission of each new fellow, the Royal Society is described as instituted "for Improving Natural Knowledge." A main means for that "improving" is discovery. In the case of natural knowledge the main road to discovery must lie in research. There are several ways in which research can be encouraged, and one of them lies in providing suitable workers with the means to devote their time freely to investigation. The society is fortunate in possessing now, to a somewhat greater extent than formerly, funds that may be considered as permanently allocated to this fundamental object; for though its existence extends now to more than two and a half centuries, financial help directed to this eminently important aim has come only relatively recently. That it should have now begun may be a sign of the arrival of an Age in some respects new; the beginning of a trend towards wider public interest in and sympathy with research.

Of events in biological science in the past year I may mention one that is attracting attention at this time. In the Physiological Laboratory of Toronto University has been prepared a pancreatic extract possessing striking power over the carbohydrate metabolism of the body. Potent as it is, experience with it is still limited. Work of urgency is required with what may prove to be a desired remedy; the first programme is further investigation of the extract's full properties, with caution as to raising hopes which practice may but partly fulfil. Such are the considerations which weigh with the Canadian—and the discovery is from a Canadian university—to whom the discovery is due. In this country the Medical Research Council has undertaken public-spirited direction of the extract's preparation and of further determination of its properties.

The physiological steps of the discovery may be briefly outlined thus:—Destruction of the pancreas is well known to produce in the dog a diabetes-like condition, rapidly fatal. The liver's store of glycogen is lost, and cannot be renewed by even liberal supply of its normal source, carbohydrate food. Sugar formation from proteins ensues, with rapid wasting of the tissues: at the same time the blood is surcharged with sugar, and the tissues are unable to make use of sugar. In a normal animal, glucose put into the circulation raises the ratio of carbon dioxide expired to oxygen absorbed, because the tissues consume the sugar. But glucose similarly introduced into the depancreated diabetic animal does not raise the respiratory quotient; the tissues no longer consume the sugar. The inference has long been that the pancreas produces some substance enabling the body to make use of sugar—some substance that in fact should control certain forms of diabetes. At Toronto there seems to have been secured the extraction of that substance.

The pancreas consists of two structures intimately commingled. One, secreting cells set round ducts into which they pour the pancreatic juice, is potently digestive: the other, scattered in tiny islets, is seemingly unrelated to the ducts though closely related to the blood channels. The want of success of pancreatic extracts in mitigating a diabetic condition might be

due to digestive powers of the juice cells destroying an anti-diabetic substance of the islet-cells. Dr. F. G. Banting determined to avoid this possibility by preparing extracts made from the pancreas after its trypsin-yielding cells had been selectively brought to atrophy by ligation of the gland ducts. He and Mr. Best, a collaborator who joined him, overcoming formidable difficulties of technique, succeeded in preparing the required material, and in examining the effect of extract upon diabetic depancreated dogs. They found the sugar fall both in the blood and urine, and that the animals, instead of dying in three weeks, remained, while treated, in excellent condition.

The further prosecution of the work afterwards engaged other collaborators: to mention them in alphabetical order, Collip, Hepburn, Latchford, MacLeod, and Noble; of these Prof. MacLeod, himself director of the Toronto Physiological Laboratory, is well known as a skilled authority in experiments on carbohydrate metabolism, and Dr. Collip is professor of bio-chemistry in the University of Alberta, though temporarily working at Toronto. With team work, advance has proceeded relatively quickly, and successful extracts are now obtained from ordinary ox and other pancreas.

Of much physiological interest is the fact that the active principle in the extract seems one normally controlling the blood-sugar in health, for its injection rapidly lessens the blood-sugar in normal animals. The extract, added to a simple perfusion fluid containing a little glucose and streamed through the isolated rabbit heart, increases three- or fourfold the heart's uptake of sugar from the fluid. The extract sometimes evokes serious nervous disturbances seemingly associated with extreme fall in the amount of the blood-sugar.

Administered to diabetic depancreated animals, the extract brings reappearance of the liver's glycogen store, while bringing down the sugar excess in the blood and the excretion of sugar and acetone in the urine; and it enables the diabetic organism to consume sugar. It also lessens or prevents hyperglycæmia produced in animals in several other ways.

Gratifying success has already attended the use of this extract in the relief of diabetic patients; much further research is, however, yet needed for development of the methods of extraction and of the routine use of the active principle.

The important physiological advance thus just reached comes as a fit reward to those who have achieved it. It is, of course, the striking result of steady work pursued by many various workers through many earlier years. Such work, we may remember, lay often open to charge by the unenlightened of being merely academic and fruitless, its reward being at the time simply the intrinsic scientific interest of the facts obtained. The Toronto investigators we may be sure would say with Pasteur, "To have the fruit there must have been cultivation of the tree." Part of the merit of the recent successful investigation has been its appreciation of possibilities indicated by previous work. But that merit is after all only a preliminary to the main achievement. The actual achievement is the deserved success of a bold attack conducted with conviction and determination and carried through in the face of formidable experimental difficulties.

<sup>1</sup> From the presidential address delivered to the Royal Society on November 30.

## The West Indian College of Tropical Agriculture.

By Prof. J. B. FARMER, F.R.S.

THE opening of the West Indian College of Tropical Agriculture by His Excellency Sir Samuel Wilson, the Governor of Trinidad and Tobago, on October 16, was an event not merely of local, but also of Imperial interest, for it constitutes a memorable landmark in the progress of agriculture throughout the British possessions in the tropics.

The idea of such a college in the West Indies owes its inception largely to Sir Francis Watts, Imperial Commissioner of Agriculture, and the project met with support both in the West Indies and at home by men alive to the pressing need for improved facilities for agricultural education and research in the tropics.

After much preliminary exploration of various possibilities it was finally decided that the College should be located in Trinidad, and few, if any, will now question the wisdom of this decision. The Government of Trinidad has presented a magnificent site of 85 acres, at St. Augustine, which appears ample for present and, so far as can be foreseen, for future developments also. The site lies about 7 miles east of Port of Spain and is situated just south of the Main East Road, close to the junction station for the eastern and southern branches of the railway. In the opinion of the present writer, the College has secured the finest site the island could offer. Not only is the land open and well drained, but it is sufficiently exposed to the trade wind, which blows through the greater part of the year, to ensure an agreeable and healthy climate.

Further important advantage accrues to the College from its close proximity to one of the principal experimental stations and farms under the control and management of the Trinidad Department of Agriculture, the director of which, Mr. W. G. Freeman, is also a member of the governing body of the College. Thus, not only will students be able to follow the raising of such staple tropical products as sugar, cocoa, rubber, coconuts, etc., on neighbouring estates under ordinary plantation methods and conditions, but they will be able to study the same crops grown experimentally, and under rigidly scientific control. They will also become acquainted with many other tropical products not usually grown in Trinidad itself, such as cotton, camphor, spices, and so on. Furthermore, at River Estate, another large experimental station, also under the Department of Agriculture, students will have the opportunity of studying methods of propagation and cultivation of cocoa and other plants under climatic conditions sufficiently different from those prevalent at St. Augustine as to afford valuable means of comparison. Apart from the intrinsic value, both economic and scientific, of the well-planned series of experiments at River Estate, the researches there are conducted on a really large scale, and scale is a matter of no small importance when starting out on agricultural investigations.

For the present the College is housed in a building of moderate size which was already in existence on the site. It has been suitably altered and equipped, and it will provide sufficient accommodation for a limited number of students pending the erection of the new

permanent buildings which it is intended shall be commenced forthwith. Residences will also be provided for the staff, and it is hoped that hostels for students may be built if, and when, funds become available. Recreation grounds for students and staff, together with refectory, common-rooms and bath-rooms, are already in existence on the site.

The future of the College is well assured. In addition to granting the site, the Government of Trinidad and Tobago have given 50,000*l.* towards the cost of erection and equipment of the College, and that Government, together with the Governments of Barbados, the Leeward Islands, and the Windward Islands, are contributing an annual subvention of a half of 1 per cent. of their revenues. The Imperial Government is also providing the sum of 15,000*l.* spread over a term of five years, on the understanding that the work of the existing Imperial Department of Agriculture in the West Indies shall be carried on by the College. The latter gains in prestige by this amalgamation, for the work of the department, begun by Sir Daniel Morris and continued by Sir Francis Watts, is widely and most deservedly appreciated throughout the West Indies. Substantial contributions have also been promised by Messrs. Fry and Messrs. Cadbury, the Empire Cotton Growers' Association, and the British Cotton Growing Association, while special mention should be made of a handsome private donation by Mr. J. W. Stephens, of Trinidad. It will be seen that the enterprise has already aroused practical interest, and this augurs well for the future.

The value to the Empire of a College so favourably situated to meet the present urgent demands for training in tropical agriculture should be sufficiently obvious to every one, and its influence will not be limited to the West Indian islands alone, but cannot fail to make itself felt over far wider areas. One may perhaps be permitted to hope that this wider interest will find an expression in returns of a practical nature.

The first year's prospectus of the College has recently been issued, and copies can be obtained from Mr. A. Aspinall at the London office of the College, 14 Trinity Square, E.C. It will be noted that the academic year has been made to conform with that of British universities, and it is a fortunate circumstance that the agricultural and climatic conditions in Trinidad happen to render such an arrangement a suitable one. The following courses and facilities for study have been provisionally arranged:

- (1) Diploma course.
- (2) One-year course in elementary agricultural science.
- (3) Courses for agricultural officers, scientific and administrative.
- (4) Post-graduate research.

The diploma course will extend over three years, and its object will be to give a thorough training in the science and practice of tropical agriculture to those students intending to become either tropical planters, investigators or experts in different branches of agricultural science or technology. These students will be required to have passed the College entrance examina-

tion, the standard of which is intended to be that of the matriculation examination of an English university, and evidence of having passed such a matriculation examination, or other equivalent test, may be accepted by the College in lieu of its own entrance examination.

The one-year course is intended for those who require a less extensive acquaintance with the scientific aspects of agriculture, and the standard required from such entrants will be based mainly on a satisfactory school record indicating that they are able to profit by the instruction offered.

Special facilities will be afforded to officers selected for the tropical agricultural services, whether under government or otherwise, such as should enable them to obtain (through courses planned to meet individual needs) familiarity with the applications to tropical conditions of the principles they will have already acquired in Europe or elsewhere. It is difficult to exaggerate the value and importance of such training to men of this class before they proceed to take up the duties of the posts to which they may have been appointed. Hitherto there has existed a gap, largely unbridged, between the university at home and the work that awaits the scientific officer in his district, where the conditions that embrace his problems and affect their solution are so widely different from those within the range of his previous experience. The new College enables this hiatus to be short-circuited, and it should now be possible for a man in a few months to build effectively on his previous knowledge of principles. In short, he is now in a position to obtain easily, and under exceptionally favourable conditions, just that kind of wide outlook over, and reasonably intimate familiarity with, the material and environment of his prospective problems so necessary for ultimately attacking them with good prospects of success.

Perhaps, however, a word of caution may not be out of place here. In order to secure the best type of scientific officer, whether for government or for other services, it is fundamentally important that he should have received that kind of broad and thorough scientific training which only a first-rate and well-equipped university is in a position to give. It is not contended, and it must not be expected, that the training now

available for scientific officers at the West Indian Agricultural College can replace this university type of education. What it can and will do is to utilise the results of that education, and to make it of more immediate and practical value. The motto of the College, *Via colendi haud facilis*, emphasises the difficulty of agricultural problems, and they are not going to be best attacked unless the best means are employed in the process. The combination of the home university and the tropical college unquestionably offers the best means at present in sight.

Finally, in its provision for research students the College is pursuing an excellent course. The West Indies, with the fine botanic gardens of Trinidad and Dominica, offer unrivalled opportunities to the botanist using Trinidad as a centre, and it would be difficult to find better facilities anywhere in the tropics. The relative freedom from noxious pests, the absence of the annoyance caused by the leeches of the eastern jungles, the variety and wealth of the vegetation, together with the striking ecological character it exhibits, combine to form a most attractive prospect for any young man who desires to secure that indispensable acquaintance with tropical vegetation without which no botanist can be said to be fully qualified to hold one of the more important chairs in the universities at home.

But it is, after all, by its success in promoting the welfare of agriculture, and of the industries that arise directly out of it, that the College will be finally judged. In this last connexion it is well to learn that technological courses are contemplated to prepare men to take their part in manufacturing processes. Some of these, for example sugar, are already of considerable importance in the West Indies and elsewhere. The establishment of a sugar school will constitute the first step in this direction, and gifts of up-to-date plant and machinery have already been generously provided by several engineering firms in Great Britain.

It will be obvious from the foregoing sketch—necessarily but an imperfect one—that the institution is making a good start. Sir Francis Watts and the little band of professors, all of whom have made their mark in various directions, will carry with them the best wishes of every one interested in the success of the great enterprise on which they have embarked.

### The Flow of Steels at a Low Red Heat.

RECENT developments in chemical engineering have called for the provision of metallic containers capable of withstanding considerable stress at high temperatures and for long periods. The investigation of the mechanical properties of steels and alloys at these temperatures has accordingly become a matter of very direct practical importance. The existing literature of the subject almost invariably consists of graphs, in which tensile test results are plotted against the temperature at which the test was made, care being taken to eliminate the disturbing, but very important, factor of time, by carrying out each test under as nearly the same conditions as possible, the duration of each test being at most a few hours, with an actual loading time of a few minutes. It cannot fairly be claimed that such information gives more

than a general indication of the relative ability of different materials to meet the working conditions usually encountered by the exhaust valve of an aero-engine or the retorts, catalyst tubes, etc., of the engineer. Certainly it does not enable a designer to construct a container which can be depended upon to maintain its shape indefinitely, at super-atmospheric temperatures when in a state of stress.

To remedy this defect in existing knowledge, Mr. J. H. Dickenson, of the Research Laboratories of Messrs. Vickers, Ltd., Sheffield, has carried out an experimental investigation, and communicated his results at the September meeting of the Iron and Steel Institute. His general conclusion is, that all the steels upon which he has worked behaved very much like highly viscous fluids at temperatures well below the

critical range ( $700^{\circ}\text{C}.$ ) and cannot be said to have any definite strength at a red heat, and that the property of principal importance to the engineer who wishes to subject highly heated steel to stress is the equivalent of the viscosity of a fluid. For the solution of a problem of immediate practical importance, he has ascertained for each of a number of steels the temperature at which the rate of flow does not exceed a very small and practically negligible amount under a uniform stress of 8.5 tons per square inch. The particular problem was the manufacture of large catalyst tubes for a synthetic ammonia process. These tubes were to be maintained at a temperature of about  $600^{\circ}\text{C}.$  under an enormous internal pressure, a long life under these conditions being essential to the economic success of the process. After due consideration it was decided to make them of a nickel-chromium alloy which was known to possess high resistance to oxidation and deformation when under stress at high temperatures.

Laboratory tests were carried out on this alloy, on pure carbon steels, on a high chromium steel, and a high-speed steel. For details of the actual experiments the original paper must be consulted. It must be noted, however, that although the mechanical conditions chosen for the tests appear to have been considered with great care, there were considerable variations in the temperature of a given test-piece which amounted to as much as  $\pm 25^{\circ}\text{C}.$  from a mean figure. Tests of two kinds were carried out: (a) those at constant load and constant temperatures, and (b) those at constant load and uniformly rising temperature. The extension temperature diagrams of the (b) series show that up to  $400^{\circ}\text{C}.$  all the steels extended alike. Thereafter, however, the curves diverged, a considerable amount of flow taking place in each case, at temperatures well below that finally reached. The range of temperature investigated extended up to nearly  $1000^{\circ}\text{C}.$

The diagrams of the (a) series present some remarkable results, of which perhaps the most striking was that of the test-piece of nickel-chromium alloy (Vikro), which extended continuously from the first day of loading (at  $625^{\circ}\text{C}.$ ) but only broke after 36 weeks.

The diagrams bring out well the enormous influence of time in determining the temperature up to which each type of steel can support a given load (in this case  $8\frac{1}{2}$  tons per square inch), and by implication a load which can be borne at any given temperature. As an example, a nickel-chromium alloy withstood the above stress under a rapidly applied load at  $965^{\circ}\text{C}.$ , whereas the same specimen cannot be expected to endure the same stress for considerable periods without suffering sensible deformation at a temperature exceeding  $600^{\circ}\text{C}.$  Working conditions such as those outlined demand a knowledge of the latter figure.

Mr. Dickenson concludes from his tests that the extension and eventual rupture of the test-piece under unvarying load is due almost entirely to viscous flow. Whether plastic flow affects the shape of the curves, and if so, whether the data will prove sufficient to enable the plastic to be separated from the viscous flow, is a question to which he has not yet found an answer. His curves are also interesting for the light which they throw upon the differing degrees of resistance to mechanical deformation at high temperatures, which the various steels exhibit. Moreover, in selecting material for resistance to stress at these temperatures, the nature of the stressing action must be taken into account.

In the second half of his paper, consideration is given to the very important factor of resistance to "scaling" exhibited by steels at the temperatures in question. It has been known for some time that remarkable resistance to oxidation is offered by certain nickel-chromium alloys, and, in a somewhat less degree, by high chromium steels. Mr. Dickenson has carried out systematic experiments on eight typical steels, in nine temperature ranges from  $550^{\circ}\text{--}600^{\circ}$  up to  $1075^{\circ}\text{--}1175^{\circ}\text{C}.$  The best results were given by a nickel-chromium alloy called "Vikro." Interesting photomicrographs are furnished, showing the varying character of the scale in the various alloys. Mr. Dickenson's research will be welcomed by chemical and metallurgical engineers, for it contains valuable information for which they have long been waiting. It is much to be hoped that he will see his way to continue his experiments.

## The Manufacture of Acids during the War.<sup>1</sup>

By Prof. T. M. LOWRY, F.R.S.

THE three technical reports before us deal with the manufacture of sulphuric, nitric, and picric acids during the war. The reports are compiled on similar lines to those of the four earlier volumes which have already been reviewed in these columns (NATURE, April 29, 1922, p. 541); and since the methods and workmanship of Mr. W. Macnab are now well known, it is not necessary to describe in detail the type of information which they contain. It may, however, be of interest to review briefly the general situation as

regards supplies of acids which had to be met by the Department of Explosives Supply, and the way in which the problem was solved by the workers of that Department, as disclosed in these three reports.

### NITRIC ACID.

Although oxidised nitrogen was the key of the supply-problem in explosives—both propellant and H.E. (just as chlorine was the basis of the supply-problem in gas-warfare in its successive phases of chlorine, phosgene,  $\text{CCl}_2\text{NO}_2$ ,  $\text{S}(\text{C}_2\text{H}_4\text{Cl})_2$ , or mustard gas, etc.)—the report on the manufacture of nitric acid is undoubtedly the least important of these three, since it is much to be hoped that this country will never again be dependent on overseas

<sup>1</sup> Ministry of Munitions and Department of Scientific and Industrial Research. Technical Records of Explosives Supply, 1915-1918. No. 5: "Manufacture of Sulphuric Acid by Contact Process." Pp. vi + 128 + plates. (London: H.M. Stationery Office, 1921.) 25s. net. No. 6: "Synthetic Phenol and Picric Acid." Pp. vi + 97 + plates. (London: H.M. Stationery Office, 1921.) 15s. net. No. 7: "Manufacture of Nitric Acid from Nitre and Sulphuric Acid." Pp. vi + 86. (London: H.M. Stationery Office, 1922.) 10s. 6d. net.

sources for its whole supply of fixed nitrogen. No more eloquent testimony to our unpreparedness in this direction could be given than the fact that, while a whole volume is devoted to the manufacture of nitric acid from nitre and sulphuric acid, there is no corresponding report on the supply of fixed nitrogen from the air, for the all-sufficient reason that there never was a supply to describe. Since, however, the two factories of Gretna and of Queen's Ferry alone were making during the war 1300 tons of nitric acid per week, and since, moreover, the loss by submarines of nitre ships from Chile was the cause of incessant anxiety, lest the whole output of explosives should be arrested by even a temporary stoppage of supplies, it was of very great importance that the utilisation of the nitre should be carried out with the highest degree of efficiency.

As usual, detailed attention resulted in economies which, in an earlier stage, would have appeared to be almost impossible. Striking evidence of the elaborate care that was called for in this very large-scale production is afforded by the fact that twenty pages of the seventh report are devoted to a description of the plant and process used for washing the sacks in which the nitre was brought from Chile! This resulted, not only in the saving of a substantial percentage of the precious nitre and in the elimination of a very serious fire risk, but also gave a higher value to the bags themselves; thus, whereas an unwashed bag could be sold for 2d., there were obtained, after washing, 60 per cent. of sound bags at 4d. each, 39 per cent. of slit bags at 3d., and 1 per cent. of ragged bags at 9-25. per ton of 1400 bags.

A more obvious source of loss arose from the decomposition by heat of a certain proportion of nitric acid into water, nitrogen peroxide, and oxygen, especially towards the end of the distillation. It is this factor which gives rise to the one important complication of the plant, namely, the provision of towers in which the nitrous fumes can be reconverted into nitric acid by contact with oxygen and water. Since this oxidation is relatively slow, it is essential to provide adequate space in the towers, in order that the gases may not pass through them too quickly. Another important point in manufacture is to secure as large a proportion as possible of nitric acid of high strength, since, as the distillation proceeds, more and more water comes over with the acid. In practice the acid was collected in two batches, the receiver being changed when the density of the distillate fell to 1.465, while the fire was extinguished when the density fell to 1.340, although a little more acid distilled over from the hot charge before the retort was tapped. In a typical case, a series of six charges gave 5.05 tons nitric acid in the form of 90 per cent. acid and 3.55 tons in the form of 83.3 per cent. acid, giving a total yield of 86.6 per cent. recovered by condensation; to this must be added, however, an estimated recovery of 5.5 per cent. in the absorption towers, giving a total yield of 92 per cent. The balance of 8 per cent. is due mainly to loss of gases from the towers, especially during the brief period of violent interaction which takes place at an early stage of the distillation; there is also a small loss of nitric acid in the nitre-cake, from which the last traces of acid cannot profitably be removed. In some instances,

however, a yield of more than 97 per cent. was reached, the total loss being therefore less than 3 per cent.

An interesting problem arose from the production as a by-product of vast quantities of nitre-cake. This was sometimes thrown away, *e.g.*, by dumping in the sea, since it was difficult to find a commercial outlet for it. It was therefore a profitable process, during an early period of the war, to neutralise nitre-cake with the poorer qualities of caustic soda, and to sell the product to the glass-makers as a substitute for salt-cake. At a later stage, however, manufacturers were persuaded to make more and more use of nitre cake in place of sulphuric acid, and the cake gradually acquired a market value, except at the more outlying factories. On the other hand, the direct-conversion process for the manufacture of ammonium nitrate from sodium nitrate and ammonium sulphate led to the production of vast quantities of sodium sulphate as a by-product, for which no sufficient outlet existed, with the result that two vast glistening pyramids were accumulated as a new object of interest to be seen by travellers on the G.W.R. just before reaching Swindon. As a result of these two factors, the neutralisation of nitre-cake was changed abruptly from a commercial operation, on which a useful profit might be earned, into one in which the product was of less value than the raw material. Under these conditions the infant industry was abandoned as abruptly as if the ashes of Vesuvius had fallen upon it and converted the plants into a modern Pompeii.

#### SULPHURIC ACID.

The manufacture of sulphuric acid involved a two-fold problem: first, the provision of sufficient supplies of chamber-acid, the manufacture of which was as well established as that of nitric acid from sodium nitrate; and, second, the manufacture of oleum, a far more difficult operation, which might indeed be compared with the fixation of nitrogen, except that the production of oleum had been carried on during many years (although on a restricted scale corresponding with the small normal demand for this material), while the fixation of nitrogen was an altogether novel enterprise in this country. Although several new chamber plants were constructed, they have not formed the subject of a report, perhaps because the production of chamber-acid was very largely left to contractors. On the other hand, new capacity for the manufacture of oleum on a large scale was provided in several Government factories, and the experience gained in constructing and working these plants is described in the fifth report of the series.

The oleum plants were of two principal types. The first plants (*e.g.* that at Oldbury) were constructed on the Mannheim system, in which the oxidation of sulphur dioxide to the trioxide is effected by the use of ferric oxide and of platinum in series. In the later plants platinum alone was used as a catalyst. The plants at Queen's Ferry, Gretna, and Avonmouth were constructed on the Grillo system, in which the platinum is supported on a base of calcined magnesium sulphate; but a plant on the Tentelew system, which is in some respects intermediate between the other two systems, since it employs platinum as the only catalyst, but in



the more familiar form of platinised asbestos, was also taken over and worked at H.M. Factory, Pembrey. The Mannheim and Tentelew plants were constructed to burn iron pyrites; in the large Grillo plants, sulphur was burnt, among other reasons, in order to reduce the size of the towers used to purify the gases. This purification has been from the beginning the most essential feature in the successful manufacture of sulphuric acid by the contact process, and is substantially the same in all the different systems. It was, however, found that, even after the most careful purification of the gases, the proportion of sulphur dioxide converted to the trioxide was lower in the Mannheim and Tentelew plants than in the Grillos, where the efficiency often reached 94 per cent. instead of something less than 90 per cent.

While, however, the report describes in detail many elaborate technical features which were essential in order to secure high yields and efficiencies, it is of interest to find that the apparently simple operation of burning the pyrites provided an opportunity for securing improved yields, that may be compared in its simplicity with the washing of nitre bags, since it was found that careful attention to the method of building up and raking the fires resulted in the reduction of the sulphur content of the spent ore from 8 to 2 per cent. This feature proved to be so important that, in addition to an accurate time-table specifying exactly when the fires were to be raked, charged, and dropped, there was actually drawn up at the Queen's Ferry factory a chart to show exactly how the prong of the rake should be dragged or pushed through the fire in order to produce the best results, and this diagram is regarded as of sufficient importance to be reproduced in the report. The report also contains a precise specification of the way in which the fire-bars must be moved in order to remove the burnt pyrites from the furnace. It was by attention to such details as these that the high efficiencies ultimately achieved in the different factories were reached.

Perhaps one reason why chamber plants did not receive more attention was that, even when T.N.T. could be manufactured without oleum, it was still found to be advantageous to supply in this form the sulphuric acid required to make up for the losses sustained during working, *e.g.*, in the form of fumes and in the various washing waters, since in this way it was possible to avoid the final stage in the concentration of the sulphuric acid, *e.g.*, from 92 to 96 per cent., which was also the most expensive and the most wasteful part of the process.

#### PICRIC ACID.

The manufacture of picric acid presented a third type of problem. At the beginning of the war this acid was the only approved filling for H.E. shells, for Land Service as well as for the Navy. The demand for the acid soon outstripped the available supplies of coal-tar phenol, and it therefore became necessary to make use of coal-tar benzene as the raw material. This could be converted into picric acid by passing either through monochlorobenzene and dinitrochlorobenzene or through sodium benzenesulphonate and synthetic phenol. In this country the latter

process was adopted almost exclusively. In France the chlorination process was also used, although in many cases the manufacture was arrested at the penultimate stage of dinitrophenol—a milder explosive, which gave rise to many fatalities before its toxic properties were realised and controlled with the help of proper physiological tests.

The manufacture of synthetic phenol lends itself to considerable variations in plant and process, and the sixth report contains diagrams illustrating five different variations worked out by different manufacturers. The subsequent conversion of the phenol into picric acid also included a considerable range of variants, which are set out fully in the report. It may, however, be of greater interest to refer briefly to the final chapters of the history of picric acid manufacture, in which the personal influence of the late Lord Moulton was a dominating feature. Convinced from a very early date that vast quantities of explosive would be required, he had laid down as a fundamental proposition the view that these could be obtained only by using ammonium nitrate as the main basis of the shell-filling programme. In this connexion the limited supplies of T.N.T. were of particular value, since this compound could be diluted with ammonium nitrate to five times its original weight, and even then gave an explosive mixture which was of greater power than, although not quite so violent as, T.N.T. or picric acid. The insensitiveness of this mixture, which ultimately became one of its most valuable properties, made it very difficult at first to secure effective detonation, and a maximum output of picric acid was therefore demanded in order to secure complete detonation of the largest possible proportion of shells. Many efforts were made to dilute picric acid in the same way as T.N.T., and in France (where picric acid was adhered to until the end of the war, in spite of its high cost) it was diluted with a wide range of other nitro-bodies; but the dilution of ammonium picrate with ammonium nitrate was never sufficiently successful to provide a service filling.

When, therefore, the detonation of the mixture of T.N.T. and ammonium nitrate had been improved until its equality with picric acid was at last established, there was no reasonable alternative but to abandon altogether the use of this acid, which cost three times as much, and, moreover, required nearly eight tons of imports, instead of less than two tons, in order to give one ton of finished explosive. Very severe criticism was levelled against Lord Moulton's action in spending more than a million pounds in erecting a factory for the manufacture of picric acid, which was abandoned almost as soon as it was finished; but this criticism was really only a proof of the ignorance of the critics, since the policy on which it was based was one that effected a saving of several million pounds per year, in addition to effecting a reduction of imports which was at the time of vital importance. In this, as in other problems, Lord Moulton saw clearly almost from the beginning what must be done to achieve success, and the closing down of the Avonmouth factory was the final vindication of the policy which he had adopted, and then followed persistently, in spite of all the obstacles that it had to encounter, until he had accomplished his purpose.

## Prof. Max Weber.

CELEBRATION OF SEVENTIETH BIRTHDAY.

THERE are few living zoologists whose researches have taken so wide a range as have those of Prof. Max Weber of Amsterdam, whose seventieth birthday has been celebrated in Holland during the present week. As naturalist-traveller by land and sea in many parts of the world, he has brought together vast collections for study by his pupils and colleagues; as anatomist and histologist, he has studied the structure and elucidated the affinities of very diverse groups of animals from flat-worms to mammals; he has written the best text-book of mammalian anatomy and conducted one of the most important oceanographical expeditions of recent times; nor has he disdained to labour as a "mere systematist" at the description and cataloguing of species of Crustacea, fishes, and reptiles.

To select for mention the most significant among contributions to knowledge so numerous and so varied is no easy task. Among the first that come to mind are Weber's demonstration that the pattern formed by the hair-follicles in the skin of various mammals can be interpreted as derived from the scaly covering of reptilian ancestors, and the evidence he has adduced for the dismemberment of the order Edentata.

As a zoogeographer, Max Weber's studies on the fauna, and especially on the freshwater fishes, of the East Indian Archipelago will have a permanent value, whether or no "Weber's line" is to replace "Wallace's line" as the accepted limit between the Oriental and the Australian regions.

An enterprise of a very different kind carried out under Max Weber's personal leadership was the exploration of the Malayan seas in the years 1899 and 1900 by the Dutch steamship *Siboga*. The stately series of reports on this expedition, which have been appearing under his editorship since 1902, form a contribution to the science of the sea scarcely surpassed in importance save by those of the *Challenger* expedition. Dealing with only a restricted area of the ocean, but paying far more attention to the fauna and flora of the shallower waters than the naturalists of the *Challenger* were able to do, it is not too much to say that the *Siboga* expedition has given a new aspect to many problems of the distribution of marine animals in tropical seas.

It remains to be added that Madame Weber (*née van Bosse*) is a botanist of distinction, who has contributed monographs on many of the groups of seaweeds collected by the *Siboga*; she has also described the minute algae which find a curious habitat on the hairs of sloths.

W. T. C.

Prof. D'Arcy W. Thompson has sent us the following letter signed by other British naturalists and himself:

DEAR PROFESSOR MAX WEBER,

You celebrate your seventieth birthday to-day, and we, who are your colleagues and are but a few of your many friends in England, join together to congratulate you and to wish you many years to come of work and happiness. By your long life of teaching and research, by your leadership of the *Siboga* Expedition, by your great handbook of the Mammalia, and by innumerable other important publications, you have come to be the acknowledged leader of zoology in the Netherlands and to be recognised far and wide as one of the most distinguished naturalists of our time. Your solid learning has upheld the great scientific traditions of your country, your investigations have influenced and stimulated many of us, your broad interests, your singleness of purpose, the simplicity of your life, and your genius for friendship have set an example to us all.

December 5.

A. ALCOCK.

E. J. ALLEN.	SIDNEY J. HICKSON.
CHAS. W. ANDREWS.	JAS. P. HILL.
J. H. ASHWORTH.	WM. EVANS HOYLE.
W. BATESON.	J. GRAHAM KERR.
GILBERT C. BOURNE.	E. W. MACBRIDE.
W. T. CALMAN.	W. C. MCINTOSH.
GEO. H. CARPENTER.	DORIS L. MACKINNON.
WM. J. DAKIN.	P. CHALMERS MITCHELL.
ARTHUR DENDY.	C. LLOYD MORGAN.
J. C. EWART.	EDWARD B. POULTON.
F. W. GAMBLE.	R. C. PUNNETT.
J. STANLEY GARDINER.	C. TATE REGAN.
WALTER GARSTANG.	G. ELLIOT SMITH.
JAMES F. GEMMILL.	OLDFIELD THOMAS.
SIDNEY F. HARMER.	D'ARCY W. THOMPSON.
J. R. HENDERSON.	D. M. S. WATSON.
W. A. HERDMAN.	A. SMITH WOODWARD.

## Obituary.

H. J. ELWES, F.R.S.

MR. HENRY JOHN ELWES passed away on November 26, after a life full of activities spread over seventy-six years. Born heir to landed property and great wealth, his life at first promised to be that of the typical English gentleman. He was sent to school at Eton, and served for five years in the Scots Guards; afterwards he became one of the greatest travellers of modern times, led on by his love of natural history, entomology, horticulture, trees, and big game shooting. He visited Asia Minor, Tibet, Nepal, India, China, Formosa, Siberia, Caucasia, North and South America, and most if not all the countries of Europe. As a

landowner, he was interested in sheep, and studied all the various breeds. He rendered important services to entomology by his enormous collections, which are now housed at South Kensington. He was a keen gardener, and introduced many beautiful and rare plants, a considerable number of which are figured in the *Botanical Magazine*. His "Monograph of the Genus *Lilium*" is a standard work. He aided several of the great scientific societies in many ways, and became president of the Royal Entomological Society of London and of the Royal English Arboricultural Society.

Mr. Elwes wrote numerous papers on gardening, agriculture, entomology, ornithology, and forestry. It is perhaps in the latter subject that his public services were

greatest. Fascinated by the study of trees, he brought out the greatest work on arboriculture that has been published since Loudon's monumental book, which appeared in 1838. He did much for the establishment and maintenance of the School of Forestry at the University of Cambridge, the fine building and wonderful collection of timbers in it owing much to his munificence.

Mr. Elwes was a man of splendid physique, endowed with great powers of observation and organisation; and he was a fine naturalist. His influence was always cast in favour of scientific methods. His many friends mourn the loss of a splendid and stimulating personality.

#### J. H. GURNEY.

THE death of Mr. John Henry Gurney will be greatly deplored by all who knew him, for he was of a singularly lovable nature, and thought no ill of any one. By this sad event, Norfolk loses her foremost naturalist—one who by work and patronage has for many years done much to advance the study of Nature in his native county. Mr. Gurney, who was seventy-five years of age, died at his residence, Keswick Hall, near Norwich, after a short illness, on November 9.

Mr. Gurney came of a family intimately associated for some generations with public affairs in Norfolk, which has been noted also for its philanthropy, and in some of its branches for a love of natural history. This devotion to the study of Nature was developed in a remarkable degree in John Henry Gurney and in his father. The latter was, in his day, the greatest authority on the birds of prey; and the son at an early age commenced to follow in his father's footsteps by devoting his attention to the study of birds, which eventually became one of the main interests of a useful life. Since the days of that remarkable man, Sir Thomas Browne (1605-1682), Norfolk has been pre-eminent among English counties for its succession of distinguished naturalists interested in local faunal investigations. Many have shared in the advance of its ornithological knowledge, including such outstanding names as Alfred Newton, Stevenson, Southwell, and the Gurneys, father and son. The latter was indefatigable in his researches and made more than 100 literary contributions to the county avifauna, including 28 annual reports, each of which brought the knowledge of the subject up-to-date; of these, the last, dealing with 1921, appeared only a few months ago.

We are indebted to Mr. Gurney for several books, the chief of which was "The Gannet, a Bird with a History"—a valuable and exhaustive contribution which will always remain a classic on its subject. Another interesting volume was entitled "The Early Annals of Ornithology." This concerns largely the British aspect of the subject, and includes much

information of interest relating to birds culled from the le Strange household accounts for the years 1519-1578. In quest of bird-lore he visited Spain, Algeria, Switzerland, and Egypt, and the results of his observations appeared in the *Ibis* and the *Zoologist*, or, in the case of the last-named country, in book form under the title "The Rambles of a Naturalist."

Mr. Gurney was one of the original members of the Norfolk and Norwich Naturalists' Society, founded in 1869, and was its president in 1881-2, 1888-9, 1898-9, and in 1919-20; he was also chairman of the Norfolk Wild Birds Protection Committee, and a member of the committee of the Norwich Museum, to which institution he was a generous donor. He was a Fellow of the Linnean and Zoological Societies, and a member of the British Ornithologists' Union.

W. E. C.

CANON EDMUND MCCLURE, whose death occurred on November 18, at the age of eighty-five years, was editorial secretary of the Society for Promoting Christian Knowledge from 1875 to 1915, during which period he controlled the great mass of publications issued by the Society. He graduated in honours both at the old Queen's University, Belfast, and at Trinity College, Dublin. He held a curacy at Belfast for ten years, and was then collated to an honorary canonry at Bristol. Among his scientific and historical works he published a Star Atlas, adapted from the German of Klein; translations of Hommel's "Hebrew Tradition," and Kittel's "Babylonian Excavations"; he also had a share in a history of the society which he served so long, and in "British Place Names." Though he did little original work, his influence on scientific and historical literature was important.

It is announced in the *Chemiker Zeitung* of November 21 that Prof. Leo Tschugaeff died from typhus on September 26 last. Dr. Tschugaeff, who was fifty years of age, was professor of inorganic chemistry at Petrograd. He was well known for his researches, including the dimethylglyoxime reaction for nickel. The issue of November 16 reports the death on November 4 of Prof. Alfred Möller, since 1896 director of the Forestry Academy of Eberswalde, who was known for his work on mycology.

WE much regret to announce the death on November 30, at sixty-nine years of age, of Sir Isaac Bayley Balfour, K.B.E., F.R.S., late professor of botany in the University of Edinburgh and Regius Keeper of the Royal Botanic Garden, Edinburgh; also on the same day, at seventy-five years of age, of Sir Norman Moore, Bt., sometime Physician to St. Bartholomew's Hospital and president of the Royal College of Physicians.

#### Current Topics and Events.

AT the anniversary dinner of the Royal Society it is customary to include among the guests some public men of distinction in other fields than those with which scientific men are concerned. Among such guests this year, at the dinner held on November

30, were Mr. Justice Darling, who proposed the toast of "The Royal Society," and Mr. L. S. Amery, First Lord of the Admiralty, who responded to the toast of "The Guests." If the assembly had consisted of leading representatives of literature or art,

music or the drama, neither of these speakers would have professed, facetiously or otherwise, want of knowledge of the functions of the institution they honoured by their presence, or of the meaning of subjects surveyed by it. Mr. Justice Darling, for example, said he had heard of the Royal Society as he had heard of the equator, and had been told that the society "concerned itself with medicine and biology, and particularly natural knowledge and natural philosophy, but the moment the knowledge became unnatural—and so far as he could see most of it was—then the society had nothing more to do with it." Of course, the society was founded for the promotion of natural knowledge by inquiry as against *supernatural* by revelation or authority. Mr. Justice Darling should understand the distinction, for he referred to Francis Bacon several times in the course of his remarks, though always incorrectly, as "Lord" Bacon. As Sir Charles Sherrington, who presided, said, "The field of truth which the society explores is in the realm of natural knowledge, and the manner of the exploration of this field is in research." Sir Ernest Rutherford was right when, in responding to the toast of "The Medallists," he referred to the spirit of adventure possessed by every scientific pioneer. In no other department of intellectual activity is this spirit more manifest, and in none are such fertile provinces being opened. To us it seems strange, therefore, that so little is commonly understood of the origin and purpose of such a body as the Royal Society, now in its 260th year, or of the achievements of modern science represented by it.

DURING the war, when the country was short of munitions, manufacturers at their wits' end for supplies of chemicals, and medical men had to use such drugs as were available instead of those most suitable for their patients, no one had any doubt that the making of these things was a key industry and that when the war was over the Government must see to it that the importer of fine chemicals from Germany should be replaced by the British manufacturers of such products. After much tribulation the Safeguarding of Industries Act was passed to achieve this end; but thanks to the political and legal discussions that have accompanied and followed its passage and the national failing of a short memory, many people have become doubtful whether there is such a thing as a key industry. Even chemists begin to wonder whether they know a fine chemical when they see one. In these circumstances it is all to the good that somebody should restate the case; and this the Association of British Chemical Manufacturers has done in a pamphlet entitled "Shall the State Throw Away the Keys?" The publication contains numerous examples of the dependence of our staple industries on a steady supply of fine chemicals, and shows that such national and Imperial functions as the care of public health and the proper administration of tropical colonies cannot be carried on without them. Some of the most essential of these materials are now made in this country; but, as Sir William Pope points out in a

foreword to the pamphlet, much remains to be done, and further developments in this direction cannot fail "if public opinion realises that a flourishing fine chemical industry is a vital necessity to the prosperity of our Empire and insists that national support is given to the young enterprise." This pamphlet should be of considerable assistance in creating an intelligent public opinion on this subject.

ON December 22 occurs the bicentenary of the death of Pierre Varignon, who will be remembered for the publication in 1687—the year Newton's "Principia" appeared—of the "Projet d'une nouvelle mécanique," the first treatise in which the whole science of statics was deduced from the principle known as the parallelogram of forces. Varignon was the son of an architect at Caen and was born in 1654. His bent for mathematics was stimulated by Descartes' work on geometry. His book immediately attracted attention, and in 1688 he was made professor of mathematics at the Collège Mazarin and a member of the Academy of Sciences. In 1704 he followed Duhamel in the chair of mathematics at the Collège de France. He suffered a good deal from ill-health, and his larger work, "Nouvelle Mécanique," did not appear till 1725. Of this treatise De Morgan once wrote, "This work was born long after its own death, and three years after its author's. The Projet of 1687 enabled all the world to act upon it; so that when the finished work was published it had long been superseded. The great feature of this work, as of the Projet, is the prominence given to the composition of forces. Varignon and Newton were forcing this commodity into the market at the same time and independently." Varignon was one of the earliest and most powerful advocates in France of the use of the differential calculus and was a correspondent of Leibniz and the Bernoullis.

EXCAVATIONS at Alfoldean, near Slinfold, a camp on Sussex Stane Street, the route by which Roman soldiers marched from Chichester to London, are described in the *Times* of November 9. Remains of officers' private quarters and of a canteen have recently been found. Among other finds was a great collection of pottery, nearly all broken, specimens of many kinds of glass, and nine copper coins ranging in date from Vespasian to the fifth-century Tetricus. Mr. Winbolt, who is in charge of the excavations, will report the results to the Sussex Archaeological Society. Another discovery, at Wisley, Surrey, is an ancient village dating between 50 B.C. and A.D. 50, which is recorded in the *Times* of November 15. It is stated that in the hut dwellings fragments of broken pottery were discovered. In 1904 a great deal of pottery was discovered and the kiln in which it was burnt, while years ago, at the foot of the village, a dug-out canoe, evidently belonging to it and associated with flint implements, was found. The canoe is now in the Weybridge Museum.

THE Elizabethan building in Croydon known as the Whitgift Hospital, dating from 1599, is once more threatened with destruction; the Town Council has given notice of a Parliamentary bill to acquire

and dispose of the Hospital and Oratory for streets improvements. The matter has yet to be passed, however, by a town's meeting and afterwards by the burgesses, before it can proceed. Several times during the past twenty-five years the building has been threatened, but every effort has so far been counteracted by the local Preservation Committee and the Croydon Natural History and Scientific Society. The Royal Institute of British Architects, which has now joined forces with the local scientific society, has adopted the view that the widening of the main road through Croydon can be achieved without any interference with the buildings. In 1912 a scheme to this effect was accepted by the Croydon Council, and approved by the Local Government Board. At a conference of interested societies called by the Institute, the local and national importance of preserving Whitgift Hospital as a valuable relic of Elizabethan architecture was emphasised, and it was decided to support the 1912 scheme as providing a practical and effective road improvement which meets traffic requirements. Steps are to be taken to place these views before the proper authorities. It is to be hoped that the principle of avoiding, wherever possible, interference with historic and beautiful buildings may be increasingly supported by public opinion.

For nearly sixteen years Lord Carnarvon, with the assistance of Mr. Howard Carter, has been engaged in carrying out excavations in part of the site of ancient Thebes on the west bank of the Nile at Luxor. Their work has now been rewarded by an astonishing success, the details of which are described by a correspondent in the *Times* of November 30, while in the next issue Sir E. Wallis Budge explains the importance of the discovery. A sealed chamber has been opened containing the tomb of Tutankhamen, son-in-law of Amenhetep IV., now better known as Aakhenaten. The latter king, whose reign is dated at the end of the 14th century B.C., became notorious for his attempt to revive the ancient cult of the sun's disc, a movement which met with such serious opposition from the orthodox worshippers of Amen-Ra, king of the gods at Thebes, that he was obliged to retire to the place now known as Tell-al-Amarnah, where he acted as priest of Aten, or the disc. The tomb furniture of Tutankhamen is of extraordinary interest and value, including his magnificent State throne, one of the most beautiful works of art ever discovered, and a mass of splendid articles which have been as yet only imperfectly examined. Sir Wallis Budge suggests with good reason that a monograph containing a full account of this remarkable discovery should be published; "Such a book, carefully planned and written by Lord Carnarvon and Mr. Howard Carter, would crown a very fine archaeological triumph, and earn the gratitude of Egyptologists, archaeologists, artists, and others throughout the world." It only remains to congratulate Lord Carnarvon and Mr. Howard Carter on the success that has attended their long course of excavation, and has produced one of the most remarkable discoveries made in Egypt in recent times.

A VERY remarkable and most valuable collection of scientific instruments of historical interest is at present on view in the Portrait Gallery of the Bodleian Library, Oxford. This collection has been formed by Mr. Lewis Evans and contains some two thousand instruments, the oldest dating from the tenth century, and among the youngest being some designed by the great-grandfather of the present owner. Mr. Evans has offered the whole of it as a free gift to the University of Oxford, on condition that suitable space and situation, meeting with his approval, be found for showing it. In the meantime the collection is to remain for exhibition in the Bodleian till the end of the summer of 1924; but it can scarcely be doubted that this magnificent gift will be gratefully accepted. By far the greater part of the collection consists of astrolabes and sundials, many of the former being of exquisite workmanship. Among them is a Persian astrolabe made by Ahmad and Mahmud, dated A.H. 374 (A.D. 984), suitable for finding the time of the day by the sun or at night by 37 stars, for finding the latitude of a place, etc. Another Persian astrolabe, ornamented with gold and silver, is dated A.D. 1227, while an equally beautiful one was made at Toledo in A.D. 1067. Passing by a number of astrolabes of European make, including one made at Oxford about 1676, we find a great variety of pocket dials, some of them having compass needles to be sensitised with loadstones, in fine mountings; also drawing and surveying instruments, and finally a library, numbering about a thousand volumes, dealing with dialling, astrolabes, and other instruments. Further particulars about this wonderful collection will be found in the *Bodleian Quarterly Record*, No. 35.

A VISIT of members of the Circle of Scientific, Technical, and Trade Journalists and representatives of the technical press to the extensive modern repair shops of the London General Omnibus Co., Ltd., at Chiswick, took place on November 27. These large works, which cover more than 30 acres and deal with the repair of a fleet of 3000 motor-buses, travelling more than 100 million car-miles in a year, have some most interesting features. The works can handle 120 vehicles weekly. The whole process of overhaul and repair is conducted on scientific lines, each vehicle being stripped, the individual parts distributed for repair, and finally reassembled on a moving conveyor in a manner reminiscent of the methods of the Ford Motor Co. One highly interesting apparatus is the special washing-machine, capable of accommodating five components such as gear boxes at a time, a caustic washing solution being pumped in at high pressure so as to wash out thoroughly all grime and grit. Three such machines are in use. There is a well-equipped canteen where 1000 men can be served with dinner in fifteen minutes, and a model first-aid department. Following the inspection of the works, an address on the "Safety First" movement in England was delivered by Mr. H. E. Blain, assistant managing director of the London Underground Railways and L.G.O. Co. group, and hon. secretary both of the London

"Safety First" Council and the British Industrial "Safety First" movement. Mr. Blain traced the growth of this movement which has made "Safety First" such a familiar term in this country, describing the work of the Drivers' Educational Committee, which has more than 7000 drivers entering annually for its awards and medals, and the equally important work done by the Schools Propaganda Committee.

At the meeting of the Chemical Society to be held at the Institution of Mechanical Engineers, Storey's Gate, S.W.1, on Thursday, December 14, at 8 P.M., Prof. C. H. Desch will deliver a lecture entitled "The Metallurgical Applications of Physical Chemistry."

The council of the Royal Agricultural Society of England has decided to revive the offer annually of a gold medal for an essay giving evidence of original research on any agricultural subject or on any of the cognate agricultural sciences.

At a general meeting of the members of the Royal Institution held on December 4, Sir Arthur Keith was elected secretary in succession to the late Col. E. H. Grove-Hills. Profs. Urbain (Paris), Ehrenfest (Leyden), Knudsen (Copenhagen), Bjerknæs (Christiania), and Dr. Irving Langmuir were elected honorary members.

A NEW feature in the activities of the Institute of Metals is the admission of student members. The main qualifications required of the new class are that they shall be between 17 and 25 years of age and that they shall be studying metallurgy; they will be admitted to all the usual privileges of full members with the exception that they cannot vote at meetings. Both the entrance fee and the annual subscription are substantially less than those paid by members. The new departure should do much to stimulate and guide, by contact with older and more mature men of science, the younger research workers in our laboratories and works.

At the annual general meeting of the Faraday Society held on November 29, the following officers and council for the year 1922-1923 were elected:—*President*: Sir Robert Robertson; *Past Presidents*: Sir R. T. Glazebrook, Sir Robert A. Hadfield, Bart., Prof. A. W. Porter; *Vice-Presidents*: Prof. C. H. Desch, Prof. F. G. Donnan, Dr. J. A. Harker, Prof. T. M. Lowry, W. Murray Morrison, Prof. J. R. Partington, and Dr. G. Senter; *Treasurer*: Robert L. Mond; *Council*: W. R. Bousfield, Cosmo Johns, Dr. R. Lessing, Prof. W. C. McC. Lewis, Prof. J. W. McBain, Dr. H. Moore, C. C. Paterson, Dr. J. N. Pring, Prof. A. O. Rankine, and Dr. E. K. Rideal.

At a General Meeting of the University of Durham Philosophical Society held on November 28, the following officers were elected:—*President*: The Earl of Durham; *Vice-Presidents*: Sir Theodore Morison, Sir Charles Parsons, Profs. T. H. Havelock, P. J. Heawood, H. J. Hutchens, Mr. Wilfred Hall; *Secretaries*: Messrs. J. W. Bullerwell, B. Millard Griffiths; *Committee*: Profs. H. G. A. Hickling, H. V. A. Briscoe, J. Wight Duff, R. F. A. Hoernle, J. L. Morison, C. J. Hawkes, F. B. Jevons, Drs. J. A. Smythe, D. Woolcott, A. A. Hall, G. R. Goldsbrough, Messrs. G. W. Caunt, A. W. Bartlett, J. L. Burchnell,

S. J. Davies, S. Hoare Collins, A. D. Peacock, and W. Clarke; *Editor*: Prof. G. W. Todd; *Librarian*: Dr. F. Bradshaw.

THE Frank Wood medal of the Society of Glass Technology has been presented to Mr. G. G. Middleton, B.Sc. Tech., and Mr. H. W. Howes, B.Sc. Tech., the successful students in 1921 and 1922, respectively, in the Department of Glass Technology at the Sheffield University. In 1919 the Society decided to recognise the services Mr. Frank Wood had rendered in connexion with its foundation and handed over to the University a hundred guineas, with the condition that the income should be utilised to provide some reward to students in the glass technology department. It was decided that the reward should take the form of a medal, and that it should be associated with the name of Mr. Frank Wood, in whose honour it had been established.

A NEW edition (No. 76) of their catalogue of second-hand scientific apparatus has been issued by Messrs. C. Baker, 244 High Holborn, W.C.1. The list is divided into the customary convenient sections, and we may direct attention in particular to two of them, dealing with microscopes and astronomical apparatus respectively. Both contain a large and varied assortment of items ranging from large modern instruments to the smallest accessories.

ANOTHER of the useful and well-arranged catalogues of Messrs. W. Heffer and Sons, Ltd., Cambridge, has reached us. Its No. is 217 and it contains the titles of upwards of 1500 works arranged under the headings Mathematics and Physics (Journals and Transactions, Books printed before 1800 and Books printed after 1800), Chemistry, Chemical Technology and Metallurgy. Many books formerly the property of the late Prof. R. B. Clifton are offered for sale.

MESSRS. WATSON AND SONS, LTD., Sunic House, 43 Parker Street, Kingsway, London, W.C.2, announce that the British Thomson-Houston Co., Ltd., and the General Electric Co., Ltd., are now associated with them. This connexion implies the development of X-ray and electro-medical apparatus constructed on established electrical engineering lines, and, with the aid of the research laboratories of these companies, the incorporation of the most recent advances in physics.

WITH further reference to the remarks which have appeared in these pages on the subject of the sense of smell in birds, Mr. W. E. M'Kechnie of Chepstow Place, London, W.2, raises the question as to whether the usually well-developed olfactory mechanism in birds may not have quite a different sensory function, such as the detection of fine differences in the strength, temperature, and humidity of the air-currents encountered during flight. This was Cyon's theory, but it rests on no sure foundation of fact. In their experiments on the homing capacities of Noddy and Sooty terns, Watson and Lashley found that these powers were not affected when the nasal cavities were occluded with wax and varnished over: the birds so treated retained their remarkable faculty of finding their way back to their nests, over an unknown course, from a considerable distance.

Our Astronomical Column.

A BRIGHT NEW STAR.—A telegram just received (December 4) from the International Central Bureau of Astronomical Telegrams at Copenhagen, reports the discovery of a new star on December 1, by Zivierel of Rumania. The star is given as of the first magnitude, and its position in R.A.  $18^h 48^m$ , and North Declination  $28^{\circ} 0'$ . It is situated just on the border between the two constellations Lyra and Hercules, but as many charts differ as to the position of the actual boundary, some uncertainty may arise as to whether the star will be called Nova Lyrae or Nova Herculis. All new stars are situated either in or on the borders of the Milky Way, and the present one is no exception, lying just on the border. The Nova will easily be picked up on a fine night, because it lies just to the south of the conspicuous constellation of Lyra, made prominent by the brilliant star Vega. The constellation is in the north-western portion of the sky in the early part of the evening. The Nova makes very nearly an equilateral triangle with the two stars  $\nu$  Lyrae and  $\beta$  Cygni and is brighter than both these stars;  $\alpha$  Lyrae, or Vega, is of magnitude 0.14, so will approximate closely to the brightness of the Nova, assuming that the latter is still of the first magnitude. This Nova is the brightest which has appeared since that of Nova Cygni, which was discovered in 1920.

COMETS.—A new faint comet, 1922 *d*, was discovered by Mr. Skjellerup at the Cape on November 25, being the second that he has found this year. Mr. Wood has telegraphed the following elements from Johannesburg: they show a strong resemblance to those of Comet 1892 VI., which are given for comparison; as it was under observation for three months without deviating appreciably from a parabola, identity is impossible, but the two comets may have had a common origin.

T = 1923 Jan. 1.14 G.M.T.	1892 Dec. 28.1.
$\omega = 260^{\circ} 31'$	$252^{\circ} 42'$
$\Omega = 261^{\circ} 8'$	$264^{\circ} 29'$
$i = 23^{\circ} 4'$	$24^{\circ} 47'$
log $q = 9.9759$	$9.9893$

EPHEMERIS FOR GREENWICH MIDNIGHT.

	R.A.	S.	S. Decl.	log $r$ .	log $\Delta$ .
	h.	m.	s.		
Dec. 8.	12	5	48	$22^{\circ} 9'$	0.0141 9.9426
	12.	12	28	56	25 35
	16.	12	52	32	28 39
	20.	13	16	28	31 20

The comet should be looked for a little east of south and very low down, just before dawn. It is near  $\epsilon$  Corvi on December 8, subsequently crossing Hydra into Centaurus.

The following is a continuation of the ephemeris of Baade's Comet for Greenwich midnight: this is still a fairly easy object with moderate telescopes.

	R.A.	S.	N. Decl.	log $r$ .	log $\Delta$ .
	h.	m.	s.		
Dec. 11.	21	55	35	$23^{\circ} 33'$	0.3643 0.3460
	15.	22	5	27	22 44
	22.	15	13	21	57
	19.	22	24	55	21 14

Perrine's Periodic Comet was found by Rakamuna on Nov. 29<sup>d</sup>, 6<sup>h</sup>, 50<sup>m</sup>, G.M.T.; in R.A.  $8^h 5^m, 32^s$ ; N. Decl.  $0^{\circ} 28'$ . Its daily motion is +16 sec., south 44'. The probable date of perihelion was about Oct. 20. The magnitude of the comet is 13.0.

PUBLICATIONS OF THE ASTRONOMICAL SOCIETY OF THE PACIFIC.—The October number of the Publica-

tions of the Astronomical Society of the Pacific contains a number of interesting communications. First there is a very clear and concise account of the work of the late J. C. Kapteyn, whom the writer, Mr. F. H. Seares, describes as one of the most distinguished astronomers of his generation. Kapteyn, as he says, presented the unique figure of an astronomer without a telescope, but reading through this notice it will be seen how he formed programmes for telescopic work, and how successfully he discussed the observations made. Director S. A. Mitchell, of the Leander McCormick Observatory, gives a list of the trigonometrical parallaxes of a number of stars of spectrum types A and B (headings of the tables reversed in error), data very much wanted for the initial work in determining parallaxes of other stars of the same type by the spectroscopic method. A summary of the year's work at the Mount Wilson Observatory is given by the director and assistant director, Dr. G. E. Hale and Mr. Walter S. Adams respectively. As announced in NATURE of October 7, a 50-foot interferometer telescope is being specially built for the Observatory, and it is hoped to determine with it the diameters of about thirty stars brighter than the fourth magnitude. Dr. R. G. Aitken contributes an interesting account of the two notable astronomical meetings, namely the International Astronomical Union at Rome and the celebration of the centenary of the Royal Astronomical Society in London. In the notes, among other subjects, mention is made of the success of the Crocker Eclipse Expedition from the Lick Observatory.

ANCIENT OBSERVATIONS OF AURORA.—A. H. Swinton directs attention in the Journal of the British Astronomical Association to some passages in early English chronicles which describe brilliant coloured streamers in the night sky; in all probability these were displays of aurora, an assumption that is strengthened by the fact that in most cases the dates of the displays are separated by multiples of the sunspot cycle. They therefore become valuable for indicating probable dates of sunspot maximum. Working backward from the well-established maximum of 1860*i* with the two assumed periods (A) 11<sup>2</sup>.156 (B) 11<sup>2</sup>.055, the following tabular values are obtained. The time of year is stated in one case only, namely, 743 Jan. 1; in the other cases the middle of the year is assumed.

Observed Date, A.D.	Tabular Date.		Observed minus Tabular.		Number of Cycles from 1860.	
	A	B	A	B	A	B
555.5	554.9	555.6	+0.6	-0.1	117	118
567.5	566.0	566.7	+1.5	+0.8	116	117
743.0	744.5	743.5	-1.5	-0.5	100	101
776.5	778.0	776.7	-1.5	-0.2	97	98
794.5	789.1	798.8	+5.4	-4.3	96	97
979.5	978.8	975.7	+0.7	+3.8	79	80

Assumption A appears on the whole to be the better; in neither case is 794.5 well represented; the original record of this does not give the year in A.D. reckoning, but states that it was "the tenth year of the reign of Brihtric, King of Wessex."

Prof. Hirayama's list of Chinese sunspots (quoted by Prof. Turner in Mon. Not. R.A.S., vol. 74, p. 99) indicates spots on the following dates: 499 Jan. 31 (3 spots seen), 826 Mar., 832 Apr. 25, 837 Dec. 25, 842 Jan. 3, 864 Feb., 874 Jan., 974 Mar. 6. These, except the second and fourth, suggest dates of maximum in fair accord with the auroral data.

## Research Items.

**SURVEYS IN SPITSBERGEN.**—In the *Geographical Journal* for November Mr. R. A. Frazer gives an account of some work which he did on the edge of New Friesland in company with Mr. N. E. Odell and Dr. T. G. Longstaff in August 1921. The party travelled north-eastward for about 25 miles from the head of Klaas Billen Bay into the highland ice of the interior. Crossing the watershed between the western and eastern drainage areas, they surveyed the salient features in a small area lying between the Mount Svanberg group to the south and the peaks around Mount Chernichev to the north. Weather and travelling conditions were bad, and time was short, but the work which was accomplished fills one of the gaps in the skeleton survey of the Russian Arc of Meridian Expedition of 1898–1902.

**DESICCATION IN THE LAKE CHAD REGION.**—In an article in the *Geographical Journal* for November on the Lake Chad region, Mr. F. W. H. Migeod returns to the much debated question of desiccation on the southern edge of the Sahara. According to Mr. Migeod there is abundant evidence of the advance of arid conditions southward into the belt of fertility in Bornu. The dry area has been steadily increasing at a great rate for at least three-quarters of a century, and apparently at a slower rate for many centuries. Mr. Migeod cites evidence from the drying up of rivers and ponds, but on the other hand he found no personal evidence of the exhaustion of wells in the part of Bornu which he visited. The evidence from changes in forest growth he does not find conclusive, but with regard to human migration, he points to the significant fact that every successive capital of the Bornu empire during the last six centuries has been south of its predecessor. The general trend of migration is southward, and whenever a new village is founded it is always in a position south of the previous site.

**PROBLEMS OF MENDELIAN RATIOS.**—Mr. R. A. Fisher gives an elaborate mathematical treatment (*Proc. Roy. Soc. Edin.* vol. 42, Part 3) of certain problems connected with Mendelian ratios. He concludes that the ratio of frequency of the various types in a Mendelian population will be stable only when selection favours the heterozygote, such factors only tending to accumulate in the stock, while other factors will tend to be eliminated. He also develops formulæ for determining the rate of mutation which is necessary to maintain the variability of a species under different conditions. We are not competent to discuss his mathematics, but some of his biological statements are perhaps open to criticism. For example, he assumes that recessive factors tend to be harmful or harmful factors recessive, whereas in man the majority of harmful factors are dominant. He also repeats the current fiction that the mutations of *E. coli* are explained by the crossing-over of balanced lethal factors.

**ABSORPTION OF WATER BY ROOT AND STEM TIPS.**—Prof. Priestley and his students have now published the fourth in their series of studies on the anatomy and physiology of the endodermis and related structures in plants. The present contribution (*New Phytologist*, vol. 21, No. 4) considers the water relations in the growing root and stem tip. Experiments of de Vries in forcing water into roots were confirmed and extended, showing that the endodermis prevents leakage of water from the stele into the cortex. At the same time the meristematic root tip before the endodermis is organised was shown to be

impervious to water under ordinary pressures. This is apparently owing to the peculiar non-cellulose composition of the cell walls in this region, in contrast to the corresponding region of the stem tip. The impervious character of this region accounts for the failure of water-leakage from root tips, and is contrary to the views of a French worker who believes that the root tip below the root-hair zone is an absorptive region.

**COAL IN SOUTH AFRICA.**—Memoir No. 19 of the Geological Survey of the Union of South Africa, issued recently, forms the first volume of a study of the coal resources of the Union of South Africa compiled by Mr. W. J. Wybergh. The coalfields dealt with are those of Witbank, Springs, Heidelberg, and the coalfields of the Orange Free State; they are all described in considerable detail, numerous analyses are given, and the general character and properties of the coals are fully discussed. It may be of interest to reproduce the author's estimate of the existing coal resources of the Union, although, as he points out, considerable deductions may have to be made from these figures for losses in working.

Witbank Coalfield . . . . .	7,926,206,000 tons
Springs area . . . . .	485,000,000 "
Nigel area . . . . .	65,000,000 "
Vischkuil-Delmas area fairly proved . . . . .	218,400,000 "
Vischkuil-Delmas area con- jectural . . . . .	1,411,200,000 "
Heidelberg South Rand area .	8,064,000,000 "
do. other areas . . . . .	965,544,000 "
Orange Free State above . . .	100,000,000 "
Total . . . . .	119,135,350,000 tons

**THE NEW BRAUN TUBE.**—Two years ago Mr. J. B. Johnson of the Research Laboratories of the Western Electrical Co., and the American Telephone and Telegraph Co., exhibited to the American Physical Society a Braun cathode ray tube operating at low voltage, and an abstract of a more complete description of the tube in its present improved form will be found in the September issue of the *Journal of the Optical Society of America and Review of Scientific Instruments*. The cathode consists of a strip of platinum covered with an oxide, the anode of a tube of platinum 1 cm. long and 0.1 cm. diameter, only 0.1 cm. from the tip of the cathode. Between cathode and anode is a metal shield with a small hole in it through which the electrons from the cathode pass. Beyond the anode are the two pairs of deflector plates at right angles to each other, which can be connected to the two sources of electromotive force which are to be compared. The electrons finally impinge on a fluorescent screen and their deflection is of the order 0.1 cm. per volt applied to the deflector plates. When the plates are replaced by coils, the same deflection is obtained per ampere turn in the coils. In the paper referred to, the hysteresis loop for iron in an alternating field and the characteristic curve for an oscillating valve tube are given. At the exhibition of the tube before the Institution of Electrical Engineers on November 16, the anode current and grid voltage curve of a valve was shown. As the cathode ray has to produce ionisation as it moves sideways, it is not possible to obtain a sharp spot at frequencies of more than  $10^5$  per second, but below that figure the slight pressure of mercury vapour in the tube ensures a sharp image. With the oxide cathode an electromotive force of 300 volts is sufficient to run the tube.



## The Royal Society Anniversary Meeting.

ON St. Andrew's Day, November 30, the Royal Society held its anniversary meeting and Sir Charles Sherrington delivered the customary presidential address, in the opening part of which he dealt with matters affecting the society itself and science generally. Speaking of research, Sir Charles Sherrington referred to the benefaction received last year under the will of the late Miss L. A. Foulerton, who by gift had already founded the Foulerton studentship. The utilisation of the bequest came under the consideration of a large and representative committee, which recommended the creation of one or more research professorships, within the field of science specified in the bequest.

The newly instituted research professorship, together with the Mackinnon, Sorby, Tyndall, Moseley, and Foulerton research studentships, all of which are of comparatively recent date, constitute something of a scheme, although they have arisen somewhat desultorily. The studentships with one or more professorships now form a series, extending, at one end, from opportunities for workers of promise to carry their careers towards fulfilment, to, at the other end, provision for men of proved achievement to devote themselves unreservedly to research. A noteworthy feature in the administration of all these research foundations is that the recipient is in no case restricted to a particular institution. The Royal Society has no laboratory of its own, and in consequence takes advantage of the facilities for research already in existence; thus its function is rather to supplement and reinforce work already in progress.

Prof. E. H. Starling has been appointed the first Foulerton professor.

Sir Richard Threlfall and Dr. D. H. Scott, on behalf of a number of subscribers, presented to the society a portrait of Sir Joseph Thomson by Mr. Fiddes Watt.

In presenting the society's medals, Sir Charles Sherrington referred briefly to the work of each recipient. The awards are as follows:—

**COPLEY MEDAL.** Sir Ernest Rutherford.—Recently, Sir Ernest Rutherford and his pupils have been especially concerned with the deflections of a particles in their passage through matter, and as a result of his experiments he has been led to the view that the positive electric charge in the atom is confined to a minute nuclear region in the atom, that that region comprises nearly the whole mass of the atom, and that it has a charge equal to the electronic charge multiplied by the atomic number of the element. In this work the  $\alpha$  particles were located by the scintillations which they produced on a zinc sulphide screen. It was found that when the screen was beyond reach of the original  $\alpha$  particles a number, relatively small, of scintillations still remained. In some cases these additional effects are due to hydrogen atoms ejected from the nuclei of the different elements by the bombarding  $\alpha$  particles; this disruption takes place at the expense of energy latent in the disrupting atom.

**RUMFORD MEDAL.** Prof. Pieter Zeeman.—Prof. Zeeman's discovery of the splitting up of spectroscopic lines under the influence of magnetic force had important results, among others, that it enabled astronomers to trace magnetic effects at the surface of the sun. Among his subsequent contributions to science is an investigation dealing with the propagation of light in moving bodies. In all earlier experiments the dispersion of light in the medium was neglected, and the irregularities in the flow of the

liquid constituting the moving body, prevented accurate measurements. To obtain greater accuracy Zeeman investigated the effects in solid substances, such as quartz or glass, giving these bodies an oscillatory velocity, and applying an instantaneous photographic method, the exposure taking place when the velocity was at its maximum.

**ROYAL MEDAL.** Mr. Joseph Barcroft.—For the last twenty years Mr. Barcroft has been prominent for his researches on the respiratory function of the blood and its relation to the activity of the tissues. He has with various collaborators worked out the changes in the normal consumption of oxygen accompanying functional activity in various representative organs—salivary gland, kidney, cardiac and skeletal muscle, and liver. He has also worked out and thrown new light on the meaning of the dissociation curve for oxygen exhibited by blood and by pure haemoglobin, and on the influence of dissolved salts upon that curve.

**ROYAL MEDAL.** Mr. Charles Thomas Rees Wilson.—Previous work having shown the important part played by dust particles in the condensation of super-saturated vapour, Mr. Wilson showed that the ions produced by the passage of X-rays act in a similar manner, thus showing the discrete nature of the ions apart from their electrical effects. Later, he was able on the same principles to render visible, and to photograph, the actual path of an a particle through a gas. More recently, while studying the phenomena of atmospheric electricity, he has measured the surface electrification of the ground, and thence the potential gradient, at any moment, and has also recorded its variation from instant to instant. Observations during the progress of thunderstorms have enabled him to estimate the amount of electricity passing in a lightning flash.

**DAVY MEDAL.** Prof. Jocelyn Field Thorpe.—Ethyl cyanoacetate has been investigated by Prof. Thorpe very fully. As a result there appeared an illuminating series of papers on the formation and reactions of imino compounds, giving rise to a variety of derivatives of naphthalene, hydrindene, pyridine, etc., and on the isomerism displayed by the glutamic acids. His paper on "Spiro Compounds" was the first of a series dealing with the effect produced by the alteration of the tetrahedral angle, consequent on ring formation, on the formation and stability of a second ring joined to the existing ring by a quaternary carbon atom common to both.

**DARWIN MEDAL.** Prof. Reginald Crundall Punnett.—Prof. Punnett was the first to find the correct interpretation of "coupling and repulsion" in inheritance, now termed "linkage." It was known that sometimes factors belonging to distinct allomorphic pairs were transmitted as if partially linked, but that also in other families the same factors might show repulsion. Prof. Punnett conceived that these two phenomena must depend on parental combination. Most of the modern interpretations of sex-limited inheritance have grown out of this discovery.

**BUCHANAN MEDAL.** Sir David Bruce.—*Trypanosoma Brucei*, the causal organism of tsetse-fly disease, is so named after its discoverer, Sir David Bruce, who likewise first showed its causal connexion with that disease and with nagana. Bruce took a leading part in the elucidation of trypanosome infections, and in the adoption of counter measures against them, and also traced the incidence in man of Mediterranean fever to transmission through the milk of goats. During the war he carried out the collection and analysis of data regarding tetanus on

a scale never previously attained, and later was instrumental in establishing the origin of trench fever and its transmission by lice.

**SYLVESTER MEDAL.** Prof. Tullio Levi-Civita.—The investigations by Levi-Civita in pure geometry were the necessary foundations for the important physical discoveries of Einstein and Weyl. Levi-Civita has also shown himself one of the most fertile and original of investigators in differential geometry and theoretical mechanics.

### Live Specimens of Spirula.

By Dr. JOHS. SCHMIDT, Leader of the *Dana* Expeditions, Copenhagen.

**F**EW animals have been of more interest to zoologists than the little cuttle-fish Spirula. Related to the extinct Belemnites, and characterised by having an interior, chambered shell, it occupies an isolated position among recent species. Dead shells (see Fig. 2) are found on the sea-shores particularly of warmer seas, where they may drift ashore in great numbers, but the animal itself has hitherto ranked among the greatest zoological rarities, of which only very few museums possess a specimen.

On the third *Dana* expedition we captured considerable numbers of Spirula in the North Atlantic, and were also fortunate enough to observe many specimens alive. I propose then, in the following, to describe some of our observations, throwing light upon the habits and occurrence of the species.

**Appearance.**—The following remarks apply to living specimens, a point which should be emphasised, as both colour and shape are often appreciably altered by preservation: The body, or mantle, is shaped like a cylinder cut away abruptly at the back, the head and arms protruding from the front part. As seen in Fig. 1, the arms are most often kept close together, as for example when the animal is in

motion, giving the anterior part of the body a conical shape. At the hinder end are two fins, roughly semi-circular. Their basal parts are not parallel, but converge toward the ventral side of the animal. The fins can be pointed straight out behind (Fig. 1), or laid flat in against the hinder part (Fig. 2). In the centre of the latter, between the two fins, there is a circular disc (the terminal disc) having in the middle a small bead-like organ. At the outer edge of the disc is a ring of pigment; otherwise it is colourless. The small central bead is a light organ.

The colour differs from that of other cuttle-fish. The mantle has a peculiar whitish sheen, most resembling that of asbestos. A further similarity to the mineral lies in the fact that the surface of the mantle is often somewhat frayed or fluffy. The greater part of the mantle is without pigment; some colour there is, however, of a rusty red, in a narrow band along the anterior margin of the mantle, especially on the dorsal side. There is also pigment on the hinder end of the body and at the base of the fins. On touching a live specimen, the rusty colour at the hinder end will often almost disappear, the chromatophores contracting to little dark specks.

**HUGHES MEDAL.** Dr. Francis William Aston.—Dr. Aston, by the use of an ingenious method of focussing positive rays, has shown that a large number of the elements are complexes consisting of two or more kinds of atoms, having identical chemical properties but differing in atomic weight by one or more units. Except in the single instance of hydrogen the atomic weight of each constituent is, to the limit of accuracy, a whole number on the basis of oxygen —16.

Arms and head exhibit the silvery sheen and also pigment, the latter dense and of a rusty brown. The extremities of the arms, however, especially of the two longer ones, are somewhat lighter and lacking pigment. The funnel also is pigmented, but not at its mouth.

**Movements, etc.**—The movement of the Spirula is characterised throughout by the presence of the interior, chambered shell, which is situate at the posterior end of the body, and tends to lift this portion in the water. A specimen recently dead, or a live one not inclined to active movement, will therefore, if placed in an aquarium with sea water, rise to the surface, and remain suspended there head downwards, with the lighter, posterior part uppermost. If moved from this position, it will immediately swing back to it again, like a weighted tumbling figure.

On board the *Dana* we frequently observed live specimens of Spirula. When taken from the net and placed in an aquarium, they would at first invariably remain suspended at the surface of the water, motionless, and to all appearance lifeless. As a rule, however, death was only simulated. Left to themselves, they would generally come to life, and soon begin breathing and other movements. The respiratory movements are effected by rhythmical contractions of the mantle, whereby water is forced out through the funnel. As the mouth of this is turned towards the rear—i.e. upwards—the water flows up along the ventral side of the mantle. This vertically ascending current of water is easily noticeable, from its disturbing the frayed surface of the mantle.

Like other cuttle-fish, Spirula often makes swift,



FIG. 1.—Live specimen of Spirula, moving down toward the bottom of the aquarium. While so moving, the head is directed forward (downward), the fins at the rear are thrust out vertically, and the funnel is turned upward (this last is not visible here, the figure showing the specimen in dorsal view). About half natural size. Photo by K. Stephensen.

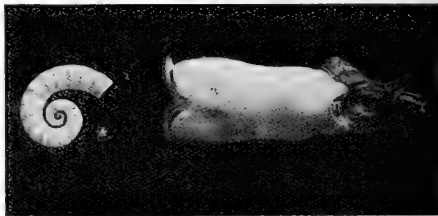

FIG. 2.—Preserved specimen of Spirula, about 39 mm. long (the head slightly damaged). The shell seen at the side, which has 33 chambers, shows the relative size of the shell in a specimen as illustrated. The animal is seen from the ventral side; the inner shell can be discerned showing through. About natural size. Photo by K. Stephensen.

jerky movements, dashing off suddenly in any direction: upwards, downwards, or from side to side. These rushes were generally made by "backing," i.e. the animal moved with its hinder end forward, having first "reversed" the funnel, so as to turn its opening forward towards the head, at the same

time flattening the fins close in to the posterior end, approximately as shown in the preserved specimen, Fig. 2. Less frequently *Spirula* was observed in the aquarium making a forward rush with its head to the front—*i.e.* without reversing the funnel. It is possible, however, that this latter mode of progress is the usual one—for example, when in pursuit of prey.

In addition to these jerky movements, the animal also makes others at a slower rate. It may often be seen in the aquarium moving vertically downwards from the surface, head first. During the descent the fins are held vertical (see Fig. 1) and move with a rapid waving or fluttering motion which, in conjunction with the current of water from the funnel, now facing upwards (to the rear), carries the animal down towards the bottom. Sometimes it will come to a standstill in mid-water, at others it will not stop until it has reached the bottom, but so long as it remains below the surface the fins are kept in motion as described, and the funnel is pointed upwards. It may rise again slowly to the surface without altering its vertical position; the fins are then sometimes seen in motion, sometimes pressed in close to the hinder end.

In order to ascertain whether this movement of the fins was necessary to maintain the animal in the vertical position, which it adopted for the most part in our aquaria, we cut off one of the fins from a specimen, selecting a large and powerful individual for the purpose. It was at once evident that the lack of a fin in no way affected the maintenance of the vertical position; what did result was that the animal was now unable to keep under water. When placed at the bottom of the aquarium, it invariably rose again to the surface. On one occasion, when guiding it to the bottom, we happened to bring the creature into contact with the glass wall, when something new was seen. On touching the wall, it spread out its arms and clung to the glass, and was now able to keep under water. We tried to move it away from the glass by prodding it with the handle of a lancet. It relinquished its hold, but only to attach itself to the lancet handle in the same way. Evidently the eight short arms are highly sensitive to touch—the two longer less so, if at all. On this occasion also we had a sight of the animal's black, horny beak, and learned that it is capable of inflicting a powerful bite, as the handle of the lancet showed.

When left to itself the *Spirula* will remain suspended for hours at the surface, or lower down in the water, always in a vertical position, and with arms more or less closed in. When violently disturbed, the animal may occasionally discharge a small cloud of greyish ink. We managed to keep some specimens alive for more than two days in our small aquaria, with no aeration of the water. Generally, however, they lived only a little more than a day.

On several occasions we were able to perceive that the small bead-like organ at the posterior end is a light organ. It emits a pale, yellowish-green light, which, from the normal position of the animal in the water, is directed upward. In contrast to the light displayed by so many other marine organisms (crustacea, etc.), which flares up and fades away again, the *Spirula*'s little lamp burns continuously. We have seen the light showing uninterruptedly for hours together.

*Mode of Life.*—The third *Dana* expedition has made captures of *Spirula* in 65 hauls from 44 stations, and in every case with implements used pelagically, without touching the bottom. The depths at which our specimens were taken varied from about 2-300 metres to about 2000'. The greatest quantities were found at depths from 300 to 500 metres; none were

taken in the upper 200 metres of the sea, though the nets were constantly drawn within this range.

Our investigations thus indicate that the species is bathypelagic, *i.e.* pelagic in deeper water layers, and so confirm the supposition advanced by J. Hjort (Murray and Hjort, "Depths of the Ocean," p. 595, London, 1910). A. Agassiz ("Three Cruises of the *Blake*," ii, p. 61, Boston and New York, 1888), who has examined a specimen of *Spirula* "dredged . . . from a depth of 950 fathoms," is of opinion that "from the condition of the chromatophores of the body, it evidently lives with its posterior extremity buried to a certain extent in the mud." This conclusion is doubtless erroneous. It would be unreasonable to suppose that the creature should thus bury its hinder part—which is lighter, owing to the shell, and also carries the light organ—in the bottom. It seems far more likely that the specimen brought up in the *Blake*'s dredge was not taken from the bottom at all, but captured higher up in the water when hauling in.

*Size, etc.*—The 95 specimens of the third *Dana* expedition vary in length from 5 to 47 millimetres (maximal length of the mantle). On arranging the measurements graphically, they fall more or less evenly distributed along the millimetre scale, with nothing to suggest the presence of different "year-classes" in the material. Judging from this, it might seem as if the propagation of the species was not restricted to a short period of the year.

At one station (St. 1157, N. of Cape Verde Islands) we found the following:—

Depth (in metres).	Length of specimens (in millimetres).
250 . . . . .	9, 17, 20, 22
300 . . . . .	7, 17, 20, 21, 22, 27, 28
500 . . . . .	15, 41
1000 . . . . .	7, 15, 19, 22

At other stations, specimens more than 40 mm. long were found both in the deepest hauls and in those nearest the surface of all the hauls containing *Spirula*.

The species seems to attain maturity at a length of about 30 mm. (length of mantle). At this length the males begin to be hectocotylised, and the specimens more than 30 mm. which we opened were found to have mature sex organs (the females with large, oblong, honey-coloured ova, besides smaller eggs).

As previously mentioned, the *Spirula* has a chambered inner shell. As the animal grows the number of chambers increases, and a turn of the shell takes place. The figures below show how the number of chambers increases with growth of the animal.

Length of mantle (mm.).	Number of chambers in shell.
12 . . . . .	16
20 . . . . .	22
38 . . . . .	34 (mature male)
44 . . . . .	38 (mature female)

Approximately, then—but only approximately—an increase of one millimetre in length answers to the formation of one fresh chamber.

While the *Dana* was at the Virgin Islands in the West Indies (St. Thomas and St. Croix), as also at Bermuda, we often found considerable numbers of *Spirula* shells on the shore. Most of the shells were damaged, but so far as could be determined the intact specimens generally had between 30 and 40 chambers, *i.e.* representing, from the above, fully-grown mature specimens. From this I must conclude that at any rate the bulk of the shells found washed up on the coasts are those of fully-grown *Spirula*

which have died of old age. When the animal is dead, and the soft parts rotting away, the shells, being lighter than water, will thus normally rise to the surface, and drift about with the surface currents,

shell here illustrated has 35 chambers, and the length (of mantle) is 39 mm. Most of the undamaged shells we found on the shore were of this size.

*Distribution.*—The first complete specimen of *Spirula* known to science was taken by the *Challenger* near the Banda Islands, west of New Guinea, and a few others were captured by subsequent expeditions (one by the *Blake* at Grenada, W.I., another by the *Valdivia* in the Indian Ocean, and seven by the *Michael Sars* in 1910 in the neighbourhood of the Canary Islands). The chart, Fig. 3, shows the localities where *Spirula* was taken by the present expedition. There were, as a matter of fact, more stations than are shown, but some lie so close together that it was impossible to indicate them on so small a chart. The stations where hauls were made which might have taken *Spirula* if present, but gave negative result, are marked by a cross. Our captures amounted to 95 specimens in all.

It will be seen that *Spirula* occurred between 10° and 35° N. Lat.: in the eastern part of the Atlantic from the Atlantic from the Canary Islands to north of the Cape Verde Islands; in the Western Atlantic from Guiana and northward to the Virgin Islands and Puerto Rico, throughout the Caribbean; and also in the Gulf of Mexico and the Florida Straits, in the Sargasso Sea, and between Bermuda and the United States of America. From our previous investigations carried out with the *Thor*, we may conclude that the species is not found in the Mediterranean, or off the west coast of Europe from Spain to Iceland.

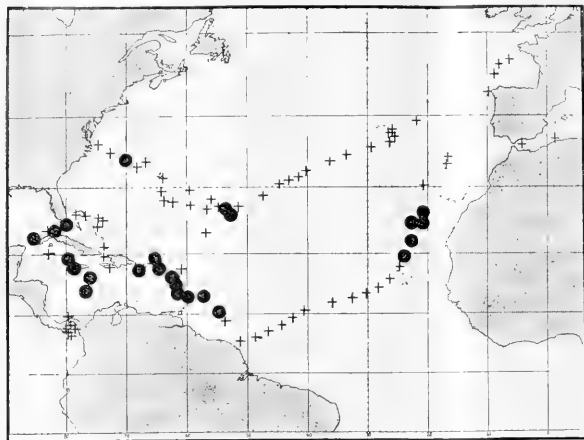

FIG. 3.—Chart showing occurrence of *Spirula* at stations of the *Dana* expedition. The black spots denote finds of live specimens, the crosses indicating stations where implements suited to its capture were used, but no specimens taken.

to be eventually washed ashore. This bathypelagic species, then, becomes after death a surface form, its remains constituting a normal ingredient in the drift of the warmer seas.

Fig. 2 serves to show the relative size of the shell as compared with that of the animal itself. The

### Solar Radiation at Helwan Observatory.

THE observations of solar radiation made at the Helwan Observatory in the years 1915 to 1921, which have recently been published,<sup>1</sup> lead to results of far-reaching importance.

With regard to the standardisation of instruments the position is satisfactory. The equipment of the Observatory includes two Ångström pyrheliometers made in Upsala as well as one made by the Cambridge Scientific Instrument Company, which was standardised by Prof. H. L. Callendar. There is also an Abbot silver-disc pyrheliometer. The observations indicate that if a correction of plus one per cent. is applied to determinations by the Upsala standard it comes into agreement with the Callendar and Abbot standards. A progressive deterioration in the Ångström instrument in daily use has been found, which is attributed to the deposit of dust on the blackened strips and a consequent reduction in absorbing power.

The usual practice at Helwan has been to take several observations in the course of a morning, with the sun at different heights, with the object of determining the "solar constant," the strength of the solar heat stream outside the earth's atmosphere. The usual assumption in reducing such observations is that the scattering and absorbing power of the atmosphere remains the same during the series of

readings. The "solar constant" is arrived at by a process of extrapolation. In an earlier bulletin Mr. Knox-Shaw has directed attention to doubts as to the validity of this assumption, and has shown that if the air becomes less clear as the day progresses then a negative correlation between the computed "solar constant" and the computed transmission coefficient is to be expected.

It is now found that there is such correlation not only at Helwan, but also at other places for which observations have been published. The correlation coefficient averages about 0.6, and the value of the determinations of the solar constant by the extrapolation method is therefore much discredited. Further evidence of its unsuitability is furnished by the lack of correlation between the values of the solar constant found at different stations on the same day. It will be for the Smithsonian Institution to show that destructive criticism on the same lines will not affect the spectrophotometer observations on which the evidence for the day-to-day variations of the "solar constant" depends.

In the year 1919 Prof. Abbot developed a new method of observation based on the well-known fact that the more the sunlight is obstructed by dust, etc., the greater will be the glare surrounding the sun. The question has been investigated by the use of a "pyranometer" (fire-above-measure), as the instrument for determining the strength of radiation from

<sup>1</sup> Ministry of Public Works, Egypt: Helwan Observatory, Bull. No. 23. Observations of Solar Radiation, 1915-1921, by H. Knox-Shaw. Price 2 P.T.

the sky is termed. The type developed by Abbot and Aldrich is described in Smithsonian Misc. Collections, vol. 66, No. 7, 1916, but the name would be suitable for Mr. Dines's instrument (*Meteorological Magazine*, vol. 55, p. 189, 1920); by analogy the Callendar radiograph, which gives a record of the heat carried by the luminous rays from sun and sky and received on a horizontal surface, should be a pyranograph.

Prof. Abbot measures the heat from the sun, and also the heat from the sun plus the heat from the sky within  $15^\circ$  of the sun with one of these instruments, and by applying appropriate factors obtains the "solar constant." Mr. Knox-Shaw has

examined a series of observations made at Calama in Chile and reduced by Prof. Abbot's staff by this method. He finds that they show no correlation between the computed values of the solar constant and the transmission coefficient. It is to be hoped that the validity of this new method will be confirmed, as it will make the regular determination of the strength of solar radiation practicable at many stations where the more elaborate routine could not be adopted. At Helwan the sun is to be observed with the Ångström apparatus once a day at a specified altitude. For the application of Abbot's method the Ångström readings will have to be supplemented by those of a pyranometer.

## Natural Gas Gasoline.

THE PRODUCTION OF LIGHT OILS FROM NATURAL GAS.

By H. B. MILNER.

NATURAL gas may be of two distinct types—dry gas or wet gas. The former consists essentially of methane, with practically no other members of the paraffin series, the latter being composed of methane with varying amounts of ethane, pentane, hexane, and heptane, and certain diluents such as nitrogen, carbon dioxide, carbon monoxide, sulphuretted hydrogen, and sometimes helium. Dry gas is normally associated with coal or decomposing vegetable matter and is rarely met with in the presence of petroleum; wet gas, on the other hand, is essentially the gas present in oil pools, either in the free state or dissolved in the oil under pressure.

The production of natural gas gasoline—as it is called—constitutes a comparatively recent development of the petroleum industry, particularly in the United States. The gas employed for this purpose is that which so frequently accumulates in the top of oil-well casings, or which, under pressure varying from a few to several hundred pounds, is forced along the flow lines leading from the casing head. Composed of lower members of the paraffin series than ordinary petrol obtained by refining crude oil, natural gas gasoline is far more volatile and inflammable, and therefore its use *per se* is normally inadmissible. But mixed with some of the heavier fractions derived from crude oil, it forms a fuel ranging from 0.660 to 0.750 in gravity, in all respects suitable for internal combustion engines of the automobile type.

There are three recognised processes for extracting oil from natural gas—the compression process, the absorption process, and the combined compression and absorption system. The compression process consists in the liquefaction by pressure and refrigeration of the heavier paraffins present in the gas, and is usually employed where the initial density of the gas exceeds 0.8, *i.e.* where the gas is rich in the heavier hydrocarbons. The plant employed entails a compressor, condensing or cooling coils and collecting tanks. The average yield of oil by this process is 2.5 gallons per m. cubic feet; 73 per cent. of the output of natural gas gasoline for 1920 in the United States was produced by the compression process.<sup>1</sup>

The absorption process has the advantage that it is applicable to "lean" gas, *i.e.* gas yielding anything from 0.1 to 0.5 gallons per m. cubic feet, and by this process much so-called dry gas has been utilised which would otherwise have been wasted, being of too low a grade to be treated profitably by the compression process. The absorption system necessitates passing

the gas through an oil of higher gravity than ordinary petrol, from which it is recoverable by fractional distillation. The combination process is a more recent development, whereby the gas is compressed under low pressure to a smaller volume, then absorbed by seal oil and subsequently recovered by distillation. This process has been employed recently by pipe-line companies in the United States to recover gasoline from low grade wet gas accumulated in gas distributing lines. The average yield of oil by the absorption process is 0.2 gallons per m. cubic feet.

The principal States in America producing natural gas gasoline are Oklahoma, West Virginia, California, and Texas, besides eight other States giving a subordinate output. The bulk of the products is sent to the northern States and California, where in the latter case the oil is mixed with petrol obtained from low grade crude oils. Much of the Canadian natural gas gasoline is being blended with petrol obtained from Mexican crude oil, and in this way, also, many oil wells which would otherwise be derelict are, by their yield of low grade wet gas, giving good results, quite apart from the better known and more valuable gas wells.

Some idea of the remarkable growth of the industry in America can be gauged from the fact that whereas only  $7\frac{1}{2}$  million gallons of gas gasoline were produced in 1911, nearly 400 million gallons were produced in 1920. This constitutes more than 7 per cent. of the total production of gasoline in the United States for that year.

Quite apart from any statistical evidence, it is clear that this new industry now firmly established in America will, by its steady progress, have a far-reaching consequence on the available supplies of fuel-oil for world consumption in the future. Many fields which have hitherto been poor producers may quite conceivably be rendered sound from a commercial standpoint by the utilisation of the natural gas now allowed to run to waste. In such countries as Russia, Persia, Burma, Egypt, and Trinidad, the processes are, by reason of the large quantities of natural gas available, especially applicable, though little, if anything, has so far been done in this direction. Wherever natural gas can be controlled at the casing head, the possibility of its treatment for the recovery of light oil should be taken into account. In the fields cited above, especially in Trinidad, the value of such recovery lies not so much in the actual production of petrol, but in the enhanced value attained by low grade crude oil fractions as a result of careful mixing.

<sup>1</sup> "Natural Gas Gasoline in 1920," by E. G. Sievers. Min. Res. Unit. States, 1920, Part II., pp. 289-300. (Unit. States Geol. Survey.)

## The Teaching of Physics to Engineering Students.

THE American Physical Society recently set up a committee to consider and report on special problems and difficulties in the teaching of physics, and the first report issued by the committee, prepared by Prof. A. W. Duff of the Worcester Polytechnic, Mass., deals with the teaching of physics to students of engineering. It summarises the opinions expressed by a large number of teachers and engineers in replies to a long list of questions addressed to them by the committee. All agree that the object of a physics course is to provide the student with a sound knowledge of the fundamental principles on which engineering depends, and that he should be shown how these principles find their application in common experiences of everyday life, so that at a later stage his knowledge of principles should be in a form immediately available for the solution of new practical problems. He must acquire the habit of searching for the principles underlying a mass of phenomena and of drawing safe conclusions from those principles. Lectures should be well thought out and the matter presented in clear form.

Some teachers think the class should be required to prepare sections of the text-book for repetition or for discussion in class, although this is felt by many to be a school method not desirable in engineering colleges. The problems set for exercise should be of a practical nature and not deteriorate into numerical substitution in a formula. Laboratory work is essential, but too great a degree of precision of results should not be demanded, the object of the work being to elucidate principles rather than attain a high order of accuracy. The relative importance of the objects to be attained in teaching physics to engineers is considered to be—first, the scientific habit of thought; second, knowledge of the laws of physics; third, initiative and ingenuity; fourth, knowledge of facts and methods; and, fifth, accurate observation.

The evidence as to present teaching in America shows that physics gets the proper proportion of time only in the best engineering colleges, and that in all cases it suffers from the inability to reason logically which most boys display on leaving school. The diversity of symbols used for the same quantity by different writers, and the difference between the engineering and scientific units, are two further difficulties under which the subject labours. A great majority of the teachers and engineers consulted were in favour of establishing a journal dealing with new instruments, methods and experiments, and recent research, applications of physics, and the theory of teaching.

## University and Educational Intelligence.

**BELFAST.**—Dr. R. C. Gray, a graduate of the University of Glasgow, has been appointed lecturer in physics in the Queen's University.

**CAMBRIDGE.**—It is proposed to create a University lectureship in crystallography for Mr. A. Hutchinson, Pembroke College.

A revised report on draft ordinances for the admission of women to the titles of degrees has been presented by the Syndicate appointed to prepare them. The chief modifications proposed are (1) that research students shall be supernumerary to the limit of 500 imposed on the number of women students receiving instruction in the University; (2) that a woman candidate for honours, who fails to qualify

for an honours degree and is "allowed the Ordinary" shall be qualified for the title of a degree; (3) that women students be allowed to enter for pass examinations in agriculture or in architecture so long as there are no Tripos examinations in these subjects. The scale of fees has been revised in view of criticisms raised at the discussion on the first report. The Syndicate makes it clear that it is not proposed to introduce a Regulation formally admitting women to instruction in the University. It is preferred to assume that the present practice of admitting women will be continued.

**LEEDS.**—Applications are invited for the professorship of chemistry shortly to be vacant by the resignation of Prof. Smithells. The salary is to be £2000. per annum, and the appointment will take effect on October 1, 1923. Applications for the post are to be sent to the Registrar, who will supply further information if desired.

**LONDON.**—An assistant lecturer in Physical Chemistry is required at University College, at a yearly salary of 300*l.* Physicists possessing a knowledge of chemistry, as well as chemists, are eligible for the post. Applications, accompanied by testimonials, record of degrees, published work, and teaching experience (if any), must reach the Secretary of the College by, at latest, Wednesday, December 20.

ACCORDING to a report prepared during the month of August for the League of Nations on "The condition of intellectual life in Austria," the professional classes and all who depend for their livelihood on intellectual work have, since the revolution of 1918, sunk into a position in which they form, in an economic sense, the lowest stratum of the community, their work being invariably worse paid than manual labour. Their physical and mental powers are consequently being sapped by insufficiency of food, and their numbers are being reduced by actual starvation. Among the organisations whereby they are striving to protect their common interests is a Central Council of Austrian Intellectual Workers, having its seat at the University of Vienna, and associated with this is an "office for providing books and instruments." This body is endeavouring to establish agreements with associations in other countries whereby second-hand or surplus books and periodicals may be obtained under conditions ensuring their fullest possible utilisation and providing for the determination of the value of Austrian books offered in exchange. One such agreement has been concluded with the Universities Library and Student Relief for Europe affiliated to the Universities Committee, Imperial War Relief Fund, General Buildings, Aldwych, W.C.2. Through this committee the universities of the United Kingdom have, during the past two years, contributed substantially towards relieving the necessities of professors and students of Austrian as well as other European universities. It is now urgently soliciting further help in money or in kind.

THE setting-up in 1918 of the standing committee of Vice-Chancellors and Principals was one of the most noteworthy events in the long history of the universities of the United Kingdom. Up to that date each university had been a law unto itself, formulating its own policy and drafting its own ordinances with little regard for the needs or the doings of the others, save in a few matters which could only be handled by the universities collectively, such, for example, as an appeal to the Chancellor

of the Exchequer or the institution of the Ph.D. degree. Outstanding interests such as these were dealt with by conferences, *ad hoc*, summoned by the Universities Bureau. At their quarterly meetings the executive heads have considered a vast number of matters of common interest, ranging from entrance tests to regulations for higher degrees, from student fees to salaries of members of staffs. After mutual consultation they report the proceedings of the committee to their respective councils and senates, which alone have power to give expression to its views, if they endorse them. When the salaries of teachers, meagre before the war, were felt by even the most enduring to be totally inadequate to meet the increased cost of living, the Association of University Teachers was formed for the purpose, in the main, of protecting the material interests of its members. We gather from the address recently delivered by its new president, Prof. J. W. McBain, of the University of Bristol, that the Association now contemplates a wider field of usefulness. It is proposed to appoint sub-committees to prepare reports on a variety of topics, to send these reports to the local associations for discussion, and finally, after the central council have hammered them into shape, to place them on record as the opinion of the Association for the benefit of the public both within and without the universities.

DR. SAMUEL P. CAPEN, the able director for several years past of the work of the American National Council on Education, was installed last month as Chancellor of the University of Buffalo. Dr. Capen, who attended the Universities' Congress at Oxford in July 1921, is well known as an authority on higher education in America. In the course of his inaugural address at Buffalo he dealt with some of the problems of urgent national importance with which educational administrators in America are confronted. Institutions of higher education of nearly every type except agricultural colleges are, he says, overcrowded, the pressure being most pronounced in the colleges of arts and sciences, where the onrush of students has threatened the efficiency of instruction. The increase in secondary school enrolments throughout the country indicates that the situation is bound to become more acute. More disconcerting than the increase in numbers in the colleges of arts and sciences are a falling off in the standard of intellectual vigour of their students, and a centrifugal tendency driving the more energetic of them to courses with such distinctly vocational aims as commerce, journalism, home economics, and industrial chemistry. A university, Dr. Capen says, is a place maintained at great expense to foster the philosophic point of view and stimulate constructive thinking, and its resources should not be consumed by those who are incapable of such things. It may be impracticable at present to devise tests which would prevent their admission, but it is relatively easy to identify them when they have been for a little while in college and "if the faculty can stand the strain" to eliminate them. As early as possible in the college course there should be provision of opportunities for independent study as in the case of honours students in British universities (whose work, by the way, is, Dr. Capen says, superior in quality to that which any American college student is required to perform), and none should be allowed to graduate who have not "demonstrated capacity for independent study and registered definite mastery of some field of study." Thus he would have American colleges adopt and apply generally to all candidates for degrees the British universities' system of honours schools.

## Calendar of Industrial Pioneers.

**December 10, 1631.** Sir Hugh Myddelton died.—A successful London goldsmith and banker, Myddelton projected and carried through the scheme for bringing water to London from springs at Chadwell and Amwell in Hertfordshire. The New River Works were begun in 1609 and completed in 1613, the canal being 10 feet wide and more than 38 miles long. There are memorials to Myddelton at Islington, Holborn, and the Royal Exchange.

**December 10, 1896.** Alfred Bernhard Nobel died.—The founder of the five Nobel prizes, for which he bequeathed a sum of 1,400,000*l.*, Nobel was born in Stockholm, October 21, 1833, worked for a time in his father's torpedo works at St. Petersburg, and after returning to Sweden took up the study of explosives. Dynamite was patented by him in 1867, in 1876 he patented blasting gelatine, and in 1888 he produced ballistite. With his brothers he established factories in various countries and took a share in the exploitation of the Baku oil-fields.

**December 11, 1906.** Jacques Augustin Normand died.—A descendant of a family of shipwrights who constructed ships at Honfleur in the 17th century, Normand became head of the well-known firm at Havre in 1871, and as such had a great share in the development of fast torpedo craft. In 1880 he built eight torpedo boats for the French Government, and in 1895 constructed the *Forban*, which for a time was the fastest vessel in the world. She was 144 feet long, and on trial on September 26, 1895, while developing 3975 horse power, reached a speed of 31.029 knots.

**December 11, 1909.** Ludwig Mond died.—Born in Cassel, March 7, 1839, Mond studied chemistry under Kolbe, Kirchhoff, and Bunsen, and first came to England in 1862. He introduced into England the ammonia-soda process of Solvay in 1873 with Brunner, founded important works at Winnington near Northwich, and about 1879 invented the Mond producer gas plant and discovered a method of manufacturing pure nickel. He was one of the greatest industrial chemists of his time and a generous benefactor of science. He founded the Davy-Faraday Laboratory at the Royal Institution.

**December 12, 1849.** Sir Marc Isambard Brunel died.—Originally an officer in the French Navy, Brunel fled from France during the Revolution, and after a short time spent in America came to England in 1799. Among his greatest achievements were the invention of the famous block-making machinery for Portsmouth Dockyard and the construction during the years 1825-1843 of the Thames Tunnel, considered at the time to be one of the sights of the world.

**December 13, 1882.** William Thomson Henley died.—From a porter in the London Docks, Henley rose to be one of the largest makers of telegraph cable. Starting in business as an instrument maker in 1838, he made apparatus for Wheatstone, exhibited an electro-magnetic machine at the Exhibition of 1851, and altogether made some 14,000 miles of submarine cable.

**December 16, 1816.** Charles, third Earl Stanhope died.—An ardent politician, and the brother-in-law of Pitt, Stanhope was also known for his love of the physical sciences and his inventive ingenuity. He constructed calculating machines, patented a process of stereotyping, introduced the Stanhope press, and attempted to drive a ship by steam.

E. C. S.

## Societies and Academies.

LONDON.

**Royal Society, November 23.**—Sir Charles Sherrington, president, in the chair.—T. E. Stanton: On the characteristics of cylindrical journal lubrication at high values of the eccentricity. The arc of contact of the film was limited in extent in the experiments and the intensity of pressure was considerably higher than in normal practice; the arcs of contact varied from 14 to 35 degrees and the maximum intensities of pressure from 1.4 to 3.5 tons per sq. inch. In all the cases observed, the pressure distribution in the film has been in accordance with the hydrodynamical theory of Osborne Reynolds. By means of a careful determination of the pressure distribution in the film, and a measurement of the radius difference of bearing and journal, sufficient data have been obtained to calculate the viscosity of the lubricant and the attitude and eccentricity of the bearing. The values of the viscosity of the lubricant so calculated were in good agreement with those determined in a viscometer, and it was concluded that the calculated values of the eccentricity were trustworthy. In the case of a journal 2.5 cm. diameter, the least distance apart of the surfaces was found to vary from 0.0012 to 0.0024 mm.—J. H. Jeans: The propagation of earthquake waves. Earthquake waves are regarded as being compounded of a number of free vibrations of a non-homogeneous gravitating earth. In 1885, Lord Rayleigh discussed a certain type of surface waves which would travel over the earth's surface with a velocity of about  $0.92 \sqrt{(\mu/\rho)}$ . It is now shown that there are additional, and far more numerous, surface waves which travel with velocities  $\sqrt{(\mu/\rho)}$  and  $\sqrt{(\lambda+2\mu)/\rho}$ . If such waves are generated by an earthquake at any point close to the earth's surface, they will refocus themselves upon this point after intervals which are integral multiples of  $2\pi a \sqrt{(\rho/\mu)}$  and  $2\pi a \sqrt{(\rho/(\lambda+2\mu))}$ , the numerical values of these quantities being about 223 and 126 minutes respectively. In 1917, two series of earthquakes, each originating from the same centre, had their times given approximately by formulæ of the type—

$$t = t_0 + n_1 \times 125.8 + n_2 \times 222.0 \text{ minutes.}$$

It is possible that the return of waves sent out by one shock may produce a second shock by a kind of "trigger" action.—F. A. Lindemann and G. M. B. Dobson: A theory of meteors and the density and temperature of the outer atmosphere to which it leads. All major meteoric phenomena can be accounted for consistently if the luminosity of the meteor be attributed to the collision of volatilised meteoric vapour with the air molecules. From observed meteoric data the density of temperature of the air at great heights is derived in four independent ways which give consistent results. The density above 60 km. appears to be very much greater than corresponds to an isothermal atmosphere at 220° Abs., and the temperature appears to be in the neighbourhood of 300° Abs. The radiative properties of ozone may account for this high temperature.—F. C. Thompson and E. Whitehead: On the changes in iron and steel at temperatures below 280° C. Iron shows abnormalities of rate of increase of electrical resistance and electric potential against platinum at well-marked temperatures. Below 280° C. these temperatures are: 55°, 100°, 120°, 140°, 220°, and 245° C. Of these, those at 120° and 220° C. are the most important. Under the same conditions, carbide of iron possesses two well-marked points at 160° and 200° C. These may be distinct points, or the ends of a single transformation range. The

etching of cementite has been studied. Broadly the reagents which darken cementite are strongly alkaline; no acid and only one neutral solution will do this. A solution has been discovered which will enable the two forms of cementite to be differentiated micrographically, but since  $\beta$ -cementite will change to the  $\alpha$  form in a few days at room temperature, this etching is not always satisfactory. When samples of iron and high carbon steel are quenched from 280° C., the electrical resistivities differ from those obtained by slow cooling. As the material tempers these values gradually alter, till after some days they practically coincide with those obtained by slow cooling.—C. F. Jenkin: The fatigue failure of metals. A theory of the mechanism of fatigue failure in metals is offered. The theory is demonstrated by a simple model which possesses the assumed properties of the crystals forming the metal. The model, when tested like a metal test-piece, gives stress/strain curves, hysteresis loops, and the complete series of fatigue ranges of exactly the same character as those given by the metal test-piece. A method of mechanically treating a mild steel test-piece is described, which, according to the theory, should raise its fatigue range about 20 per cent.; another treatment is described which should lower the fatigue range of medium steel by about 25 per cent.—S. Brodetsky: The line of action of the resultant pressure in discontinuous fluid motion. The general solution of the problem of discontinuous fluid motion past any barrier can be expressed in terms of the variable introduced by Levi-Civita, by means of which the part of the barrier in contact with the moving fluid is transformed into a semi-circle. The form of the barrier is defined by the coefficients in a Taylor expansion. Although the components of the resultant pressure on the barrier have been calculated in terms of these coefficients, the line of action has not been found previously. The moment of the resultant pressure about a certain point is a simple function of the first four coefficients of the above expansion.—R. A. Houstoun: An investigation of the colour vision of 527 students by the Rayleigh test. Lord Rayleigh discovered in 1881 that if homogeneous yellow is matched with a mixture of homogeneous red and homogeneous green, some persons require much more red, others much more green in the mixture than the normal. Such persons have been called "anomalous trichromats." Apparatus similar to Rayleigh's was employed in the present survey. In the case of the 104 women, the frequency curve is almost a perfect case of normal variation; in the case of the men, the normal curve is present, and outside it lie the colour blind and the anomalous trichromats; the anomalous trichromats are much fewer in number than would be expected from Rayleigh's original paper.

**British Mycological Society, November 18.**—Mr. F. T. Brooks, president, in the chair.—M. C. Rayner: Calluna "cuttings." Adventitious roots produced from the leafy region of the stem showed infection by the mycorrhizal fungus from the shoot tissues. The results are completely at variance with those of Christoph.—Miss G. Gilchrist: Bark canker disease of apple caused by *Myxosporium corticolium*. The disease is characterised by the formation of large longitudinal scars on the sides of branches which increase rapidly towards the end of summer, and the production of wound gum. The fungus seems to be a weak parasite, except under certain conditions when the trees may be killed outright. Infection may occur from a dead spur, grafting wounds or from the region of the ground.—R. J. Tabor: A new fungal disease of cacao and coffee. The fungus, which is a Phycomycete, shows the



amphigynous type of fertilisation similar to certain species of *Phytophthora* and has a conidial stage similar to that of *Muratella*.—Miss E. S. Moore: The physiology of the dry-rot disease of potatoes in storage caused by *Fusarium caryuleum*. The existence of seasonal and varietal differences in susceptibility was confirmed. The amount and type of fungus growth is related to the carbohydrate and nitrogen supply, to the reaction of the medium and the temperature of incubation.—A. Castellani: Mycology in tropical medicine. The history of our knowledge of fungal diseases and the chief human parasites and their effects were considered.

Zoological Society, November 21.—Sir S. F. Harmer, vice-president, in the chair.—A. Smith Woodward: A skull and tusks of a mammoth from Siberia.—D. Seth-Smith: The shed lining of the gizzard of a hornbill.—Ivor G. S. Montagu: On a further collection of mammals from the Inner Hebrides.—F. R. Wells: The morphology and development of the chondrocranium of the larval *Clupia harengus*.—R. I. Pocock: The external characters of the beaver (*Castoridae*) and some squirrels (*Sciuridae*).—G. M. Ververs: On the cestode parasites from mammalian hosts which died in the Gardens of the Zoological Society of London during the years 1919-1921; with a description of a new species of *Cyllochorda*.—A. Loveridge: Notes on East African birds (chiefly nesting-habits and stomach-contents) collected 1915-1919.—E. A. Stensjö: Notes on certain Crossospermata.—Ekenranath Ghosh: On the animal of *Scaphula* (Benson), with a description of a new species of *Scaphula*.—J. H. Lloyd and Edith M. Sheppard: A contribution to the anatomy of a hammerhead-shark (*Zygæna malleus*).—R. H. Mehra: Two new Indian species of the little-known genus *Aulodrilus* (Bretscher), aquatic Oligochaeta belonging to the family Tubificidae.—J. Stephenson: The Oligochaeta of the Oxford University Spitsbergen expedition.—R. J. Ortlepp: The nematode genus *Physaloptera*, Rud.

Royal Meteorological Society, November 22.—Dr. C. Chree, president, in the chair.—A. H. R. Goldie: Circumstances determining the distribution of temperature in the upper air under conditions of high and low barometric pressure. An analysis was given of 165 observations of upper air temperature made from aeroplanes, data being classified according to whether the air was "equatorial" or "polar." The main conclusions are—(a) that in high-pressure systems there would usually be found, either a surface layer of polar air and above it equatorial air with the high stratosphere associated with low latitudes, or equatorial air all the way up; (b) that in low-pressure systems there would usually be found either (i.) all polar air and the low stratosphere of high latitudes, or perhaps (ii.) equatorial air which had been "let down" by retreating polar air, or (iii.)—near the centre of cyclones—a mixture of polar and equatorial air. These features alone would go far towards explaining (1) the absence of correlation between temperature and pressure near the surface, (2) the high positive correlation from 3 to 8 kilometres, (3) the greater height of the stratosphere over high than over low pressure, (4) the negative correlation between temperature and pressure in the stratosphere.—Rev. José Aigué: The Manila typhoon of May 23, 1922. This typhoon traversed the central part of the Philippines in a north-westerly direction on May 20 to 23, the centre having passed practically over Manila on the morning of May 23. Manila missed the worst of the storm, and, although the barometric minimum in the present case, 742.3 mm. (29.22 inches), was lower than in the typhoons of August 31, 1920, and July 4, 1921, the damage

done was much smaller; the maximum velocity of the wind, even in a few isolated gusts, was not more than 60 miles per hour. The rate of progress of the typhoon between Surigao and Maasin was 8 or 9 miles per hour; from Romblon to Boac it moved at the rate of only 5.6 miles per hour; when nearing Manila, it increased again to about 8 miles per hour; and from Manila to Iba the rate of progress was greater than 10 miles per hour. It appears that the typhoon filled up on May 26 in the China Sea east of Hainan.

## PARIS.

Academy of Sciences, November 13.—M. Emile Bertin in the chair.—Paul Vuillemin: The morphological value of antitropic emergences. The mechanism of their production by desmonastic displacement.—Paul Lévy: The determination of the laws of probability by their characteristic functions.—W. van der Corput: Some new approximations.—M. Sierpinski: The existence of all classes of measurable (*B*) ensembles.—Pierre Fatou: Meromorphic functions of two variables.—Luc Picart: Statistics of faint stars in a limited region of the Milky Way.—Charles L. R. E. Menges: Fresnel's coefficient.—A. Perot: A rapid method of determining the elements of terrestrial magnetism. The principle utilised in the apparatus described is the production of induced currents in a coil rotating in the earth's field and the compensation of these currents by the production of a suitable magnetic field round the rotating coil. The accuracy claimed is about 0.1 per cent., and the actual measurement requires only ten minutes.—L. Décombe: The calculation of the magnetic moment of a star, starting with its axial moment of inertia, its time of rotation, and the universal constant of gravitation.—J. Cabannes: The polarisation and intensity of the light diffused by transparent liquids. Einstein's theory of the diffusion of light by liquids, based on the assumption that fluids are continuous media the properties of which vary slowly from one point to another, has not been confirmed by experiment. The modified theory developed by the author, assuming the existence of molecules, is shown to be in better agreement with fact. The depolarisation of diffused light by liquids furnishes a fresh proof of the discontinuity of matter.—Elis Hjalmar: Researches on the series of the X-rays.—P. Fleury: An electrical furnace with molybdenum resistance *in vacuo*. Molybdenum as a resistance material has certain advantages over tungsten; it is less fragile, more easily wound, does not contract strongly on first heating like tungsten, and is cheaper. Details are given of the construction of such a furnace, 4 cm. in diameter and 14 cm. high, giving a temperature of 1650° C. with a consumption of 2100 watts. At 1750° C. (2600 watts) the alumund tube fused.—H. Fischer and P. Steiner: The ultra-violet absorption spectra of pyridine and isoquinoline.—Georges Chaudron and Louis Blanc: The estimation of oxygen in steel. A comparison of results obtained by reduction of the steel with hydrogen either alone, or with the addition of various copper, tin, and antimony alloys. Both methods gave the same results.—L. J. Simon: The neutralisation of tartaric acid in presence of metallic chlorides. The neutral zone and buffer solutions.—P. Loisel: The radioactivity of the springs of the region of Bagnoles-de-l'Orne and its relation to the geological structure. There is a distinct relation between the radioactivity of the springs and the geological structure of the district. This conclusion is based on the measurement of the radioactivity of the water from twenty-eight springs.—J. B. Charcot: The geological study of the sea floor of the English Channel.—René Souèges: The embry-

geny of the Caryophyllaceæ. The last stages of the development of the embryo in *Sagina procumbens*.—P. Bugnon: The vascular differentiation for the leaf traces in *Mercurialis annua*.—Joseph Bouget: The variations of coloration of flowers realised experimentally at high altitudes.—G. L. Funke: Supplementing summer shoots (trees and shrubs).—St. Jonesco: The anthocyanic pigments and phlobatannins in plants.—L. Berger: The existence of sympathetic glands in the human ovary and testicle: their relations with the interstitial gland of the testicle.—A. Pézard and F. Caridroit: Sex-linked heredity in the Gallinacæ. Interpretation based on the existence of the neutral form and the properties of the ovarian hormone.—Alphonse Labbé: The distribution of the animals of the salt marshes with respect to the concentration of hydrogen ions.—Edouard Chatton and André Lwoff: The evolution of the infusoria of the Lamellicornia. The genus *Pelecypophrya*, intermediate between *Hypocoma* and *Sphenophrya*.—Mme. M. Phisalix: The hedgehog and virus of rabies. The hedgehog has remarkable powers of defence against rabies: it attenuates or, in some cases, destroys the virus.

### Official Publications Received.

Report on the Administration of the Meteorological Department of the Government of India in 1921-22. Pp. 14. (Simla: Government Central Press.) 4 annas.

Imperial Department of Agriculture for the West Indies. Sugar-Cane Experiments in the Leeward Islands: Report on Experiments with Varieties of Sugar-Cane conducted in Antigua, St. Kitts-Nevis, and Montserrat in the Season 1920-21. Pp. ii+43. (Barbados.) 1s.

Livingstone College. Annual Report and Statement of Accounts for the Year 1921-22. Pp. 24. (Leyton, E.10.)

The National Institute of Agricultural Botany. Third Report and Accounts, 1921-1922. Pp. 20. (Cambridge.)

### Diary of Societies.

#### SATURDAY, DECEMBER 9.

GILBERT WHITE FELLOWSHIP (in Romano-British Gallery, British Museum), at 2.30.—W. Dale: A Demonstration.

#### MONDAY, DECEMBER 11.

ROYAL SOCIETY OF ARTS, at 8.—Prof. W. A. Bone: Brown Coal and Lignites (Cantor Lecture).

SURVEYORS' INSTITUTION, at 8.—Major E. Meacher: Food Production during the War.—H. German: The Agricultural Position and the Possibility of Stimulating Economic Production in the Future.

ROYAL GEOGRAPHICAL SOCIETY (at Eolian Hall), at 8.30.—Prof. J. W. Gregory: The Alps of Chinese Tibet and their Geographical Relationships.

#### TUESDAY, DECEMBER 12.

INSTITUTION OF PETROLEUM TECHNOLOGISTS (at Royal Society of Arts), at 5.

INSTITUTE OF MARINE ENGINEERS, INC., at 6.30.—Eng.-Capt. J. A. Richards: Manufacture of Solid Drawn Steel Tubes.

ROYAL PHOTOGRAPHIC SOCIETY OF GREAT BRITAIN (Technical Meeting), at 7.—A. S. Newman: Description of the "N.S." Kinetograph Camera, with Special Reference to an Electric Drive.—Dr. G. I. Higson and F. C. Toy: The Factors which determine Gamma Infanly.

JUNIOR INSTITUTION OF ENGINEERS (at Royal United Service Institution), at 7.30.—Capt. H. Riid Sankey: The Utility of Theory to the Practical Man (Presidential Address).

QUEKETT MICROSCOPICAL CLUB, at 7.30.—Dr. C. Singer: The Early Microscopists.

ILLUMINATING ENGINEERING SOCIETY (Joint Meeting with Institution of Gas Engineers, Institution of Electrical Engineers, and Institution of Municipal and County Engineers) (at Royal Society of Arts), at 8.—H. T. Harrison and others: Discussion on Recent Developments and Modern Requirements in Street-Lighting.

SOCIOLOGICAL SOCIETY (at Leyland House, 65 Belgrave Road), at 8.15.—H. W. Nevinson: Lie in Bankrupt Vienna.

#### WEDNESDAY, DECEMBER 13.

INSTITUTION OF AUTOMOBILE ENGINEERS (at Institution of Mechanical Engineers), at 7.15.—H. Col. P. H. Johnson: Improvements in the Efficiency of Roadless Vehicles.

ROYAL SOCIETY OF ARTS, at 8.—Sir Sidney F. Harmer: The Fading of Museum Specimens.

#### THURSDAY, DECEMBER 14.

LINNEAN SOCIETY OF LONDON, at 5.—W. O. Howarth: The Occurrence and Distribution of *Festuca rubra* in Britain.—H. W. Puzley: A New British *Calamintha*.—Dr. Lily Batten: The Genus *Poly-siphonia*, a critical revision of the species, based upon anatomy.

LONDON MATHEMATICAL SOCIETY (at Royal Astronomical Society), at 5.—Prof. A. G. Dixon: Some Limiting Cases in the Theory of Integral Equations.—Prof. G. H. Hardy and J. E. Littlewood: Some Problems of Partitio Numerorum. V.: A Further Contribution to the Study of Goldbach's Problem.—A. E. Jolliffe: (1) Collinear Apolar Triads on Cubic Curves; (2) The Inflections and Inflectional Tangent of the Two-cusped Quartic.—T. Stuart: (1) The Rational Parametric Solutions of—

$$x^4 - x^2 + x^2 + x^2 + x^2 = 2A^2y^2.$$

(2) The Factors of  $2^{100} - 1$ ,  $2^{100} - 1$ .—E. C. Titchmarsh: An Expansion in a Series of Bessel Functions.—Prof. G. N. Watson: The Theorems of Clausen and Cayley on Products of Hypergeometric Functions.

INSTITUTION OF ELECTRICAL ENGINEERS, at 6.—J. Caldwell: Electric Arc Welding Apparatus and Equipment.

OPTICAL SOCIETY (at Imperial College of Science and Technology), at 7.30.—F. Smith: A Large Aperture Lens not corrected for Colour.—F. Smith: The Optical Gasue Law.—Dr. J. S. Anderson: Demonstration of the Measurement of the Internal Diameters of Transparent Tubes, and a Simple Differential Refractometer for Liquids.—E. R. Watts and Son, Ltd.: Exhibition and Description of a Constant Bubble (unaffected in length by changes of temperature).

SOCIETY FOR CONSTRUCTIVE BIRTH CONTROL AND RACIAL PROGRESS (at Essex Hall, Essex Street), at 8.—Dr. Jane Hawthorne: Birth Control as it affects the Working Mother, to be followed by a discussion.

CHEMICAL SOCIETY (at Institution of Mechanical Engineers), at 8.—Prof. C. H. Desch: The Metallurgical Applications of Physical Chemistry.

INSTITUTE OF METALS (London Section) AND INSTITUTION OF BRITISH FOUNDRYMEN (at Institute of Marine Engineers), at 8.—Dr. P. Longmir: Brass Foundry Practice.

CAMERA CLUB, at 8.15.—W. Sanderson: Florence and some Cities of the Etruscan League.

#### FRIDAY, DECEMBER 15.

ROYAL SOCIETY OF ARTS (Indian Section), at 4.30.—Commissioner F. de L. Booth Tucket: The Settlements of Criminal Tribes in India.

INSTITUTION OF MECHANICAL ENGINEERS, at 6.—G. Lumley: Reclamation Plant and its Operation.

JUNIOR INSTITUTION OF ENGINEERS, at 7.30.—W. T. Marchmont: Notes on Printing Machinery.

#### SATURDAY, DECEMBER 16.

BRITISH ECOLOGICAL SOCIETY (Annual Meeting) (at University College), at 4.30 A.M.—Dr. R. Lloyd Praeger: Dispersal and Distribution (Presidential Address).—Dr. Cockayne's Work on the Tussock Grassland of New Zealand (Lantern and Specimens).—J. Ramsbottom: The Mycology of the Soil.—W. H. Pearsall: Plant Distribution and Basic Ratios.

BRITISH PSYCHOLOGICAL SOCIETY (Annual General Meeting) (at University College), at 3.—S. J. F. Philpott: The Analysis of the Work Curve.—H. Gordon: Hand and Ear Tests.

#### PUBLIC LECTURES.

#### SATURDAY, DECEMBER 9.

HORNIMAN MUSEUM (Forest Hill), at 3.30.—Miss M. A. Murray: Ancient Egypt and the Bible.

#### MONDAY, DECEMBER 11.

ROYAL COLLEGE OF SURGEONS OF ENGLAND, at 4.—F. W. Twort: The Nature of Ultra-microscopic Viruses. (Succeeding Lectures on December 12, 15, 18, and 19.)

CITY OF LONDON Y.M.C.A. (186 Aldersgate Street), at 6.—Sir Robert Armstrong-Jones: Fatigue and how to Combat it, for the City Worker.

#### TUESDAY, DECEMBER 12.

IMPERIAL COLLEGE OF SCIENCE AND TECHNOLOGY, at 5.30.—Prof. T. J. John: Fossils and What They Teach (Swiney Lectures). (Succeeding Lectures on Tuesdays, Thursdays, and Fridays—12 in all.)

INSTITUTE OF INDUSTRIAL ADMINISTRATION (at London School of Economics), at 8.—R. Twelvetrees: Standardisation of Repairs in Relation to Industrial Economy (to be followed by a Discussion).

#### WEDNESDAY, DECEMBER 13.

ROYAL INSTITUTE OF PUBLIC HEALTH, at 4.—Dr. C. W. Saleeby: Sunlight and Childhood.

#### THURSDAY, DECEMBER 14.

ROYAL COLLEGE OF SURGEONS OF ENGLAND, at 5.—W. G. Spencer: Vesalius and his Delimitation of the Framework of the Human Body (Thomas Vesary Lecture).

ROYAL SOCIETY OF MEDICINE, at 5.15.—Sir Arthur Newsholme: Relative Values in Public Health; (2) Degrees of Preventability of Disease, etc.

UNIVERSITY COLLEGE, at 5.30.—Prof. T. Okey: Carducci.

CENTRAL LIBRARY, FULHAM, at 8.—F. T. Roche: The Influence of Finance on Industry.

#### SATURDAY, DECEMBER 16.

HORNIMAN MUSEUM (Forest Hill), at 3.30.—H. N. Milligan: Animals without Teeth.

# NATURE

A WEEKLY ILLUSTRATED JOURNAL OF SCIENCE.

*"To the solid ground  
Of Nature trusts the mind which builds for aye."*—WORDSWORTH.

No. 2772, VOL. 110

SATURDAY, DECEMBER 16, 1922

[PRICE ONE SHILLING

Registered as a Newspaper at the General Post Office.]

[All Rights Reserved.]

## NEWTON'S EPISCOPE

for the projection of  
**OPAQUE OBJECTS**  
including  
MAPS, DRAWINGS,  
DIAGRAMS, PRINTED  
and TYPED MATTER,  
ILLUSTRATIONS,  
NATURAL OBJECTS,  
etc.

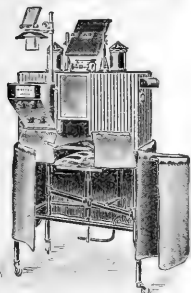

*Price list on application.*

Opticians to  
H.M. the King. **NEWTON & CO.** Estab. over  
200 years.  
*Specialists in Optical Projection Apparatus for Visual Instruction,*  
**72 WIGMORE STREET, LONDON, W.1.**

**REYNOLDS & BRANSON, Limited,**  
Chemical and Scientific Instrument Makers to His Majesty's  
Government (Home and Overseas Dominions), Laboratory  
Furnishers and Manufacturing Chemists.

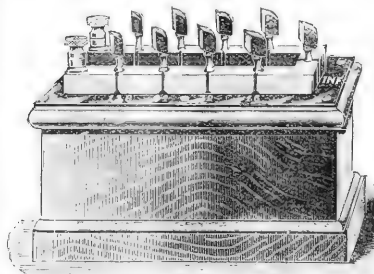

Resistance Boxes, P.O. Boxes, etc., manufactured in our own  
Workshops.

*See Physical Catalogue (Oct. 1921). Post free on application.*

**Wireless Apparatus and Accessories supplied.**

Also New Catalogues of Chemical Apparatus, Chemicals and Reagents.

**14 COMMERCIAL STREET, LEEDS.**

**BAIRD & TATLOCK (LONDON) LTD.**

SCIENTIFIC INSTRUMENT MANUFACTURERS  
and LABORATORY FURNISHERS.

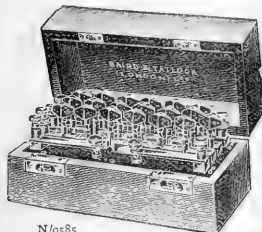

N/9585  
RESISTANCE BOX

Physical  
Apparatus  
for  
Schools  
and  
Colleges.

**14-15 CROSS STREET, HATTON GARDEN, LONDON, E.C.1.**

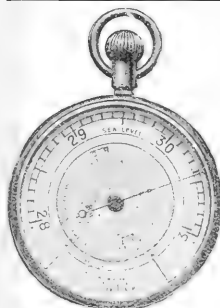

The Weather  
Watch is an ideal  
Christmas Gift.  
It forecasts the  
weather for the  
coming 12 hours.

In case

**£7 10 0**

**NEGRETTI & ZAMBRA**  
38, HOLBORN VIADUCT, E.C.1.  
LONDON.

**THE SIR JOHN CASS TECHNICAL INSTITUTE,**

Jewry Street, Aldgate, E.C.3.

The following Special Courses of Instruction will be given during the Lent Term, 1923:—

**THE MATHEMATICAL THEORY AND APPLICATIONS OF STATISTICS.**

By E. C. SNOW, M.A., D.Sc.

A Course of Ten Lectures on the modern mathematical methods of dealing with statistical data in social, educational, economic, meteorological and medical problems, suitable to teachers and to students of economics, meteorology and medicine. Facilities will be given to students who wish to undertake special investigations and research work on subjects associated with the course of instruction.

Fridays, from 7 to 9 P.M.

The First Lecture of the Course will be given on Friday, January 12, 1923.

**ALTERNATING CURRENTS AND ELECTRICAL OSCILLATIONS.**

By D. OWEN, B.A., D.Sc., F.Inst.P.

A Course of Ten Lectures accompanied by Practical Demonstrations, and intended for post-graduate students and those otherwise qualified to pursue this branch of electrical science and its applications in wireless telegraphy and telephony.

Tuesdays, from 7 to 8.30 P.M.

The First Lecture of the Course will be given on Tuesday, January 9, 1923.

Detailed Syllabus of the Courses may be had upon application to the Office of the Institute, or by letter to the PRINCIPAL, CHARLES A. KEANE, D.Sc., Ph.D., F.I.C.

**GRAHAM SCHOLARSHIP IN PATHOLOGY.**

The Senate of the University of London invite applications for the GRAHAM SCHOLARSHIP in PATHOLOGY, value £200 per annum for two years, founded under the will of the late Dr. Charles Graham to enable "a young man to continue his pathological researches and at the same time to secure his services to the School of Advanced Medical Studies connected with University College Hospital as a Teacher under the direction of the Professor of Pathology."

The successful candidate will be expected to take up the Scholarship as from April 1, 1923. Intending applicants who desire fuller information of the conditions on which the Scholarship will be held, may call personally on the Professor of Pathology, University College Hospital Medical School, W.C.1., after having made an appointment. The Scholarship is in no way restricted to students either of University College Hospital Medical School or any other Medical School of the University of London.

Applications addressed to the Principal Officer, University of London, South Kensington, S.W.7, must (a) be accompanied by the names of not more than three referees, one at least of which should be the name of some Professor, Lecturer, or Teacher of the University or College in which the Candidate has conducted his studies in Pathology, (b) state the research upon which the applicant proposes to work, and (c) be received not later than the first post on Monday January 1, 1923. Envelopes should be marked "GRAHAM SCHOLARSHIP."

E. C. PERRY, Principal Officer

**DORSET FIELD CLUB.****AGRICULTURAL CHEMISTRY.**

THE CECIL MEDAL and PRIZE of £10 will be awarded in May 1923 for the best Paper on "Recent Advances in Chemistry as applied to Agriculture, with special reference to Dorset conditions." Open to Persons aged 17-35; born in Dorset or resident One Year between May 1, 1921 and 1923.

Particulars from Mr. H. POUNCEY, Dorchester.

**THE UNIVERSITY OF LEEDS.****DEPARTMENT OF AGRICULTURE.**

Applications are invited for the position of additional INSTRUCTOR in HORTICULTURE. Salary £230. Applications will be received up to December 20, 1922, and should be addressed to the REGISTRAR, The University, Leeds, from whom further particulars may be obtained.

**WANTED, for editorial office of the**

JOURNAL OF THE TEXTILE INSTITUTE, young man trained in science and with literary ability, to take up duties immediately with a view to appointment as Editor; full-time service. Applicants stating qualifications (including modern languages), and commencing salary, to GENERAL SECRETARY, Textile Institute, 26 St. Mary's Parsonage, Manchester.

**UNIVERSITY OF CAPE TOWN.****SENIOR LECTURESHIP IN PHYSIOLOGY.**

The University invites applications for the POST of SENIOR LECTURER in the DEPARTMENT of PHYSIOLOGY at a salary of £450 per annum rising by annual increments of £25 to a maximum of £650 per annum. (The successful applicant, if a qualified medical practitioner, will be allowed a salary of £500 for the first three years of his appointment.)

An allowance of £40 will be made for passage money. The lecturer must become a member of the University Teachers' Superannuation Fund. The successful applicant will be expected to assume duty on March 12, 1923, or as soon thereafter as possible. Salary commences from date of assumption of duty.

Applications and copies of testimonials, all in duplicate, must reach the SECRETARY, Office of the High Commissioner for the Union of South Africa, Trafalgar Square, W.C. (from whom Forms of Application and further particulars may be obtained), not later than January 31, 1923.

**UNIVERSITY COLLEGE, LONDON.****ASSISTANT LECTURER IN PHYSICAL CHEMISTRY.**

Applications, accompanied by testimonials, record of degree or degrees obtained, published work, and teaching experience (if any), are invited for the above post. Salary £300 per annum. Physicists who possess a knowledge of Chemistry, as well as Chemists, are eligible for the post. Applications to be sent as soon as possible, and not later than December 20, to the undersigned, from whom further particulars can be obtained.

University College, London,  
Gower Street, W.C.1.WALTER W. SETON,  
Secretary.**HARPER ADAMS AGRICULTURAL COLLEGE.****NEWPORT, SALOP.**

Applications are invited for the post of ADVISORY MYCOLOGIST. Particulars of the appointment may be obtained on application to the PRINCIPAL, to whom all applications, together with copies of three recent testimonials, should be addressed not later than December 18, 1922.

**B.Sc. (Lond.) has calculating machine and can undertake computing in any quantity.** Box No. 38, c/o NATURE Office.

**YOUTH, 17½, secondary education, 18 months' experience works laboratory, oils, fuels, metals, desires position, excellent references.**—R. C. D., 55 Waldron Road, S.W.13.

**SPECIAL MICROSCOPICAL SLIDE:**

Radium. Perpetually giving off numerous flashes of intense light. Post free, 2s. 3d. DARLSTON, 31 Freer Road, Birchfield, Birmingham.

**The Misses FARRAN**  
10 Bell Yard, Temple Bar, W.C.2,  
HAVE CONSIDERABLE EXPERIENCE IN  
**COPYING SCIENTIFIC MS.**

AND ARE PREPARED TO  
UNDERTAKE ANY QUANTITY.

**EDUCATIONAL FILMS FOR SALE**

A Collection of 250 Films (about 150,000 ft.), one "The Building of the British Empire," 10,000 ft., another "The Dorsey Expedition," 27,000 ft., and others dealing with Travel, Industry, Nature Study, Science, etc.

For particulars of subjects and price per film apply to

MACMILLAN & CO., LTD.,  
ST. MARTIN'S STREET, LONDON, W.C.2.



SATURDAY, DECEMBER 16, 1922.

## CONTENTS.

	PAGE
Science and the Empire . . . . .	797
Wegener's Drifting Continents. By Prof. Grenville A. J. Cole, F.R.S. . . . .	798
A New Treatise on Chemistry . . . . .	801
Physiology of Respiration. By Joseph Barcroft, F.R.S. . . . .	803
Our Bookshelf . . . . .	804
Letters to the Editor:—	
Echinoderm Larvæ and their Bearing on Classifica- tion.—Dr. Th. Mortensen . . . . .	806
Rotary Polarisation of Light. ( <i>With diagrams.</i> ) —Prof. F. Cheshire; Dr. A. E. H. Tutton, F.R.S. . . . .	807
Space-Time Geodesics.—Dr. Alfred A. Robb, F.R.S. . . . .	809
A New Type of Electrical Condenser. ( <i>Illustrated.</i> ) —Dr. T. F. Wall . . . . .	810
Sex of Irish Yew Trees.—Dr. C. J. Bond, C.M.G. The Physiography of the Coal-Swamps. By Prof. Percy Fry Kendall, M.Sc., F.G.S. . . . .	811
The Royal College of Science for Ireland. ( <i>Illus- trated</i> ) . . . . .	814
Obituary:—	
Sir Isaac Bayley Balfour, K.B.E., F.R.S. . . . .	816
Sir Norman Moore, Bt., M.D. . . . .	817
Current Topics and Events . . . . .	818
Our Astronomical Column . . . . .	821
Research Items . . . . .	822
Physiological Aspects of Physical Measurement. By Sir John Herbert Parsons, C.B.E., F.R.S. . . . .	824
The Design of Railway Bridges . . . . .	825
The Alps of Chinese Tibet and their Geographical Relations. By Prof. J. W. Gregory, F.R.S., and J. C. Gregory . . . . .	826
The Present Position of the Whaling Industry . . . . .	827
Biometric Studies . . . . .	827
University and Educational Intelligence . . . . .	828
Calendar of Industrial Pioneers . . . . .	829
Societies and Academies . . . . .	829
Official Publications Received . . . . .	832
Diary of Societies . . . . .	832

Editorial and Publishing Offices:

MACMILLAN &amp; CO., LTD.,

ST. MARTIN'S STREET, LONDON, W.C.2.

Advertisements and business letters should be  
addressed to the Publishers.

Editorial communications to the Editor.

Telegraphic Address: PHUSIS, LONDON.

Telephone Number: GERRARD 8830.

## Science and the Empire.

**D**URING the past few weeks the minds of many electors in Great Britain must have been disturbed by the storms of rhetoric, appeals to occupational interests, and promises of a Golden Age in the near future, which are common characteristics of a general election. We have seen dozens of election addresses, and almost all of them profess the desire to promote industrial development, and thus reduce the burden of unemployment. The solution of this problem is not, however, so simple as it seems on paper, and is not, moreover, solely a matter of adjusting the conflicting claims of capital and labour. The third pillar of the tripod upon which the structure of modern civilisation has been erected is creative science, yet scarcely a candidate referred to it as an essential factor of national stability as well as of progress.

This is perhaps not surprising, as the number of voters engaged in scientific research or familiar with its productive value is negligible in comparison with the electorate in general upon whose suffrages in bulk depends the position of a candidate at the poll. It is also a consequence of the fact that scientific investigators as a body do not in the public Press or on the public platform assert their claims, or pronounce their principles, so vociferously as do advocates of many social changes and reforms of relatively trivial importance. It is true that there is a National Union of Scientific Workers, but it is a Trade Union affiliated, we believe, to the Labour Party, and it exists to secure suitable conditions of work and payment for its members rather than for the extension of natural knowledge. It is therefore concerned with occupational interests alone, and has almost nothing in common with our scientific societies which month by month add more to the store of human knowledge than was gained in a century in some earlier epochs of modern history. Whatever may be thought of the strength of our position in any other respect, it cannot be questioned that as regards output of originality and inventiveness British men of science are in the front rank of the scientific army and often bear the banner in the van of progress.

We have every reason to be proud of our pioneers who to-day, as in the past, are cutting a way through virgin forests into new lands of promise from which others will gather the fruits; yet their names are mostly unknown even to our political leaders, and their works arouse no interest in the market place. Scientific men are usually indifferent whether the public gives attention to their work or no; theirs is the joy of the chase, and others may dispute over the spoils. This unworldly attitude may excite respectful admiration,

and we should be sorry to suggest that scientific investigators themselves should seek to get into the limelight or take part in the turmoil of politics. They are much better employed in the laboratory than in Parliament. What are wanted, however, are advocates of science and scientific method—men and women who know the disinterested spirit in which purely scientific inquiries are carried on and desire to introduce into social and political discussions the same impartial attitude towards evidence and fearless judgment upon it. At the present time it is in a large measure the mission of science to rebuild a shattered civilisation, not alone by providing the foundations for material progress, but also by introducing scientific methods and the scientific spirit into all fields where questions of national significance are debated.

To attain these ends there must be a much wider understanding of the service of science than exists at present. Science will not advertise itself, but there is every reason why believers in it should undertake a publicity campaign on its behalf. Dozens of interesting leaflets or short pamphlets might be written showing what science means to progressive industry and modern civilisation, and they should be distributed in thousands both to enlighten and to stimulate. Wireless telephony, for example, is a direct product of purely scientific studies. The tungsten used for the filaments in the thermionic valve and in metallic filament lamps generally, was discovered more than a century ago. It enters into the constitution of all high-speed tool steels and every magneto. Manganese, nickel, titanium, aluminium, and other essential constituents of the alloy steels now used for many engineering purposes were all first discovered in scientific laboratories. So also were the thorium and cerium used in the manufacture of incandescent gas mantles, calcium carbide for the production of acetylene gas, the methods of extracting nitrogen from the air to produce nitrates for explosives and agricultural fertilisers, and hundreds of other substances and processes which are now accepted as part of our daily life without a thought of their origin.

The most remarkable of such developments is that of helium gas discovered by Sir Norman Lockyer in the sun in 1868, found in terrestrial minerals by Sir William Ramsay twenty-six years later, and now being produced in millions of cubic feet from certain oil wells in the United States, where all airships are compelled to use this gas instead of hydrogen. It is quite possible that the practical monopoly of helium which America possesses in its rich sources of supply, may be of great significance both in the arts of peace as well as those of war. At any rate, the United States Government is quietly accumulating vast quantities of the gas com-

pressed in cylinders for whatever needs the future may bring.

It is obvious that valuable national and Imperial service can be performed by a body which has sufficient funds to undertake active propaganda work for the extension of an understanding of the influence of scientific research and its results. The only organisation which is attempting to do this is the British Science Guild, founded in 1905 to convince the people, by means of publications and meetings, of the necessity of applying the methods of science to all branches of human endeavour and thus to further the progress and increase the welfare of the Empire. The Guild is thus not a scientific or technical society but a body of citizens united for the purpose of making the Empire strong and secure through science and the application of scientific method. Its relation to the work done in our laboratories is that of the Navy League to the Royal Navy—to watch and promote progress. Lord Askwith has just accepted the presidency of the Guild in succession to the Marquess of Crewe, who has reluctantly had to withdraw from this office on account of his appointment as British Ambassador at Paris.

Active steps are shortly to be taken by the Guild to secure adequate funds for displaying the fertility of British science not only throughout the Empire but also to the whole world. We possess a great treasure, and in these days cannot afford to let it lie hidden. It is devoutly to be hoped, therefore, that when the British Science Guild makes its appeal for funds and members there will be a rich and ready response to it, so that branches may be established throughout the Empire for the strengthening of the foundations of the knowledge upon which our position among the nations of the world depends. The British Empire Exhibition to be held in 1924 will provide an opportunity for showing what science has accomplished, and we look to a body like the British Science Guild to see that the promoters provide in the Exhibition a Temple of Science which shall be worthy of the great achievements of British genius.

### Wegener's Drifting Continents.

*Die Entstehung der Kontinente und Ozeane.* By Dr. Alfred Wegener. Dritte gänzlich umgearbeitete Auflage. Pp. viii + 144. (Braunschweig: Friedr. Vieweg und Sohn, Akt.-Ges., 1922.) 9s.

HOWEVER much conservative instincts may rebel, geologists cannot refuse a hearing to Dr. Alfred Wegener, professor of meteorology in the University of Hamburg. As an oceanographer, he looks out over the boundaries of sea and land; as a meteorologist, he is interested in changes of climate in

the past. Like many scientific workers, he feels that a recognition of the Permo-Carboniferous ice-age compels him to put forward an explanation. Like them, he overlooks the fact that a century of speculation as to the causes of the glacial epoch of far more recent times has left us with a score of hypotheses amid which we wander unconvinced. The evidence of the occurrence of ice-ages becomes more and more cogent as observation spreads, and it is highly probable that they have a common cause. Prof. Wegener, in laying stress on the differences between equatorial and polar temperatures at the present day, takes up the position of greatest difficulty, and regards a regional refrigeration as necessarily connected with the poles. He does not look beyond our planet and the atmospheric conditions that now prevail. It is evident that Prof. Spitaler's laborious inquiries as to zonal fluctuations will not content him, though this author believes that he has drawn the Permo-Carboniferous glaciation into his uniformitarian net. Wegener's suggestions are far more heroic; he will shatter the outermost layer of the crust to bits, and remould it, by successive arrangements of the pieces, nearer to his heart's desire. His theme is fascinating, and his style is admirably lucid. His fondness for "hüben und drüben," a phrase, we believe, derived from Goethe, makes us wonder if he treats the globe as lightly as it was treated in the "Hexenküche." For him indeed "sie klingt wie Glas; sie ist von Ton, es giebt Scherben."

As is well known, Wegener has been much impressed by the easterly salient of S. America and the easterly indent of the African coast. If we could assure ourselves that these were at one time, and at the right time, actually in contact, most of the problems of oceanic islands, of palæoclimatology, and of the distribution of land-organisms, would be solved. Would not the instability of S. America in regard to Africa imply a similar instability between N. America and Europe, of which there is (p. 81) some geodetical evidence, accepted by Wegener, but much open to discussion? If the Atlantic is a crustal rift, the other oceans are likely to have had a similar origin. The primary crust, the silica-alumina layer, which Wegener calls *sial* in preference to Suess's less distinctive word *sal*, broke open and gave rise to continental blocks and accessory islands, which float, and even waltz, upon the *sima*, the silica-magnesia layer that underlies them.

There is a concluding figure in many Bantu dances—it survives even in folk-dances at Skansen—where two partners turn back to back, bump, and part again. The possibility of this figure on a continental scale is thrilling and attractive. If Africa once parted from

America, she may woo her mate again as years pass by. The hand of the philosopher may be laid on the great land-blocks, and the occurrence of Glossopteris in India or of *Geomalacus maculosus* in Kerry may be explained by a simple process of "Verschiebung." If the fitting is not sufficiently accurate, some plasticity is granted to the sial blocks, and "Umwälzung" is also possible (pp. 35 and 41).

Wegener's conception, however, must not be taken in the spirit of a jest. Experiments on the force of gravity, made over very wide areas, have established the existence of a mass-defect under mountain-ranges and a mass-excess under lower grounds and oceans, and the sea-floor may be justly regarded as consisting of *sima* in large degree. It has long been recognised that a crumpled crustal mass bulges both upward and downward; it displaces what we now call *sima* in the depths. On the theory of isostasy, it maintains its elevation above the general surface by the fact that it displaces matter the specific gravity of which is greater than its own. Like ice in water, it floats, with a certain portion unsubmerged.

The analogy with ice is seized on by Prof. Wegener. If icebergs shift their places and "calve" by cracking on their flanks, why should not continents do the same? Let us grant that the level of the *sima* is reached at a less depth than that of the ocean-floors; the latter must then be composed of *sima*, and over them the buoyant continents may meet, and waltz, and part again. Of course they may do so; but when we are asked (p. 101) to look for the *sima* level about 100 fathoms down, or in some rare and dubious cases at 250 fathoms, we find that the rocks familiar to us on the land-surface are held to extend very little beyond the ordinary continental shelves. The chalk and flints dredged from 600 fathoms off western Ireland will require a new explanation. In depth, the continental blocks may go down to 100 km. Their relations to the earth as a whole, on this supposition, are shown on the same longitudinal and vertical scale in an expressive section following a great circle between S. America and Africa. The two continents are seen to be well immersed in *sima*. *Sima* (p. 113) behaves under pressure like sealing-wax, and sial like wax. Hence crumpling occurs in the sial blocks when they are pressed against the *sima*, though the latter in time yields and flows. Higher temperature in the depths assists this flow, and (p. 105) inclusions of *sima* in the base of sial blocks assist, by their greater fluidity, the yielding of the sial under folding thrusts.

We have now before us Wegener's view of the possibility of great horizontal displacements of the continents. The author points out (p. 6) that H. Wettstein in 1880 regarded the continents as subject to a

westward drift; but he viewed the oceanic areas as representing sunken land. This widely accepted notion is rejected by Wegener at the outset.

We may ask why the skin of a contracting globe became too small for the interior, and split along rifts which ultimately widened into oceans. The answer is that our globe is not contracting. It may even be expanding through rise of temperature, and Joly's conclusions are quoted as to the influence of radium in the crust. Wegener thinks that Pickering, when, in 1907, he fitted Africa and S. America together in a retrospect, was wrong in assigning an Archæan age to the great rent. The present separation (p. 7) must have occurred since Cretaceous times, if we are to account for the similarity of structural features in the two continents. That is to say, if we reject the notion that the ocean-floors represent subsided land, and if we find similar successions of strata, and ranges with similar orientations, in two separated continental blocks, these blocks must have drifted apart. We should observe the importance of that first "if"; if we agree with Wegener's hypothesis of the inadequacy of vertical movements of the crust, we are in a fair way towards salvation. "Die Theorie der Kontinentalverschiebungen vermeidet alle diese Schwierigkeiten." Even if contraction is going on below, horizontal contraction of the continental surfaces, by "Zusammenschiebung" and consequent crumpling, goes on faster (p. 11), and this causes a rending of the sial. To Wegener this does not seem to open up a new series of "Schwierigkeiten." It explains so much that it seems to require little explanation. Yet is not this a return to the conception of a Great First Cause? Accept that, and all thereafter will run smoothly.

Here again we may be charged with speaking lightly. Wegener is dealing with possible natural events. Build up an earth on certain lines, endow its parts with certain properties, some of which are suggested by well substantiated experimental work, and certain results are rendered probable.

The great length of geological time can always be appealed to as a factor. We may now ask what causes continental lands to drift and waltz. We learn (p. 132) that there is a tendency for the blocks to move towards the equator, like other bodies capable of sliding over the main curved surface of an oblate and rotating earth, and that a westward drift may also be expected. The island-loops, the garlands, are detached portions left behind; oceanic islands, however much they may be disguised by igneous upwellings, however much they may resemble volcanic cones built up from the depths, are similar fragments stranded on the sima, children that could not keep pace with their parents in the movements of the continental dance.

This is perhaps the boldest stroke of all; but the suggestion is continued on a larger and more serious scale. New Zealand is bereft of a relative that has hurried forward as Australia, Ceylon is cast off from the foot of India, Madagascar from the African flank. Prof. Wegener reads widely, and he uses biological and geological details that suggest analogies and former continuities. He quotes even (p. 40) Lange Koch's recent tracing of the Caledonian folding into Greenland (see NATURE, vol. 110, p. 91), though he fails to recognise the significance of *Sigillaria* in S. Africa or of *Glossopteris* in northern Russia (p. 68). Having rejected the probability of land-bridges and sunken regions, the floor of the Indian Ocean becomes for him a sheet of sima, left bare by separation of the continents, and we need no longer look wistfully for the lost forests of Gondwana Land, as the flying fish come on board to tell us of the secrets of the seas.

The trough-valleys that have been traced from Suez to the Shire River, though their origin is still under discussion, are regarded as signs of a rift that threatens Africa. In Fig. 36, p. 117, we have the author's view of what may occur under such a trough; since the walls are separating, room is allowed for a sinking down of fragments from them, while sima is rising under them from below. It is obvious that a melting off of the base of subsiding portions in the sima, such as the author elsewhere contemplates, would allow of a very different representation, and that Wegener's drawing is inspired by his rejection of vertical movements in the sial. Even fjords, despite their barriers of continuous rock, are for him cracks widening by lateral movement as an ice-load presses on the coast.

Wegener's strong case against general movements of subsidence and evatelon lies of course in his discovery (pp. 19-21) that the great majority of ocean-depths lies near 4700 m. below, and of land-heights near 100 m. above, the level of the sea. Attention was directed to this by the reviewer in NATURE (vol. 109, p. 202) of the second edition of Wegener's work. The conception of flotation is thus strongly supported; but it is already part of the doctrine of isostasy. Geological difficulties in Wegener's hypothesis are discussed by Philip Lake in his review of the second edition in the *Geological Magazine* for August 1922. Literature accumulates on the subject, and we have to consider such general papers as those of Harold Jeffreys "On certain geological effects of the cooling of the earth" (Proc. R. Soc., vol. 100, Sect. A, p. 122, 1921), where account is taken of the fracturing of a primitive crust, and such local studies as those of H. A. Brouwer on the garland-isles of the Dutch East Indies (Journ. Washington Acad. Sci., vol. 12, p. 172, 1922). Brouwer regards the garlands as the crests of growing anticlines,



based on crumpling masses that have a considerable lateral as well as vertical movement. Meanwhile, Wegener, flinging down his gage, certainly calls on us to justify such faiths as we at present hold. His principal geographic rearrangements are shown in a series of small maps, in one of which the northern lands are rearranged so as to explain the latest glacial epoch. The Permo-Carboniferous glaciation presents difficulties, as was pointed out in a notice of the excellent papers by Du Toit (*NATURE*, vol. 109, p. 757); but Wegener, when he has clustered his land-masses around the pole, shifts the pole from his point among them, to suit their special idiosyncrasies. Nothing daunts so bold a champion. The hand of the master presses on the sial blocks or on the polar axis, and all goes well with the hypothesis.

Has the author considered, however, that no groupings of the furniture of the earth will account for the simultaneous reduction of ice-masses in all glaciated regions at the present day? Can, moreover, the evidence for general rises of temperature in the past be so lightly set aside? Can—but these questions are endless; those who still hope for simple explanations may well turn their eyes for light and inspiration, with Akhenaten, to the sun.

GRENVILLE A. J. COLE.

### A New Treatise on Chemistry.

*A Comprehensive Treatise on Inorganic and Theoretical Chemistry.* By Dr. J. W. Mellor. Vol. 1. Pp. xvi + 1065. Vol. 2. Pp. viii + 894. (London: Longmans, Green and Co., 1922.) 3s. 3s. net each vol.

THE writing of a "Comprehensive Treatise on Inorganic Chemistry" presents a problem which becomes more and more difficult with each successive year. The small text-books of a century ago soon required to be expanded into a series of volumes such as were issued by Watts in 1868, and in the English translation of Gmelin, of which 19 volumes were issued between 1848 and 1872. In recent years the growth of the subject has been so rapid that nearly all the more recent successes have been scored by teams of workers, such as those who have collaborated in the production of Thorpe's "Dictionary of Applied Chemistry" in England, and of Moissan's "Traité de chimie minérale" in France, as well as in the more recent German productions. Even so, as Dr. Mellor reminds us in his preface, the seventh edition of Gmelin, begun in 1905, is not yet completed, while three other unfinished compilations date back to 1905, 1900, and 1874 respectively. For every reason it is greatly to be hoped that Dr. Mellor will be able to carry through

to completion the series of volumes of which the first two have now been issued.

In reviewing these two volumes (and perhaps paying more attention to the first than to the second), it is necessary in the first place to offer respectful homage to the author for the vast range of accurate information which he has gathered together. Almost every item of fact appears to have been abstracted from the original sources, and by a system which has left very little room for casual errors. It is, moreover, remarkable to find that an author, whose interests have generally been thought to centre themselves in the mathematical and physical aspects of chemistry, should be in a position also to deal in such an able manner with other topics, such as the early history of the science, which occupies a substantial portion of the first volume. In these chapters his references are often more numerous and earlier than those which are given in the more formal histories; thus, included in volume 1 are a number of unexpected references to the history of combustion before Jean Rey, of oxygen before Priestley, and of crystallography before Haüy, while volume 2 contains, on page 419, an amazing quotation from Roger Bacon, from which it might perhaps be supposed that metallic sodium had already been prepared in the thirteenth century! If the historical portion of the volume is dull reading, the major portion of the blame must be ascribed to the infertile character of the science during two of the three periods into which its history is divided by the author, namely, the first or mythological period, and the second or philosophical period, before it finally reached in the seventeenth century the third or scientific era. Certainly the 50 pages which are devoted to these preliminary stages fully justify the policy which has been adopted generally by teachers, even of historical chemistry, of curtailing within the narrowest limits the study of everything prior to about 1600 A.D. A lingering doubt as to whether this early period is quite so dull as it appears has, however, been raised in the mind of the reviewer by the sudden arousal of his interest when, on page 107, a series of quotations are given from a translation of Lucretius instead of a mere second-hand summary of his views on atoms.

The materials for the Treatise have already been used in part in the author's "Modern Inorganic Chemistry"; conversely, the treatise bears evidence that it has been based, in part at least, upon an expansion of the text-book. This hypothesis at any rate serves to account for some features in the arrangement of the treatise which are awkward and perhaps undesirable. Thus, in a text-book, which the student is expected to read consecutively from cover to cover, and in which the assumption is made that the reader

may begin with no previous knowledge of the subject, it is a well-known device to alternate the theoretical and the experimental sections; but this method is surely out of place in a treatise which is so extensive that it can be used only as a work of reference. In such a treatise it is merely an annoyance, and a source of unnecessary trouble to the reader, to break up the text in this way. Thus the systematic account of ozone and hydrogen peroxide is sandwiched between unrelated chapters on the kinetic theory and on electrolysis, to the obvious disadvantage both of the theoretical and the descriptive portions of the book. In the same way, and presumably for the same reason, a valuable section on chemical affinity has been buried in a chapter on hydrogen, together with a section on mass action, while sections on catalysis, on consecutive reactions, and even on neutralisation, are hidden away in a chapter on oxygen. In each of these cases the index alone gives the clue as to where the author has concealed his hidden treasures. It is perhaps even more bewildering to discover a long discussion of the indices of refraction of liquids and vapours in a chapter on crystals and crystallisation. In all these cases reference to the theoretical sections is rendered unnecessarily difficult by the way in which certain portions have been detached and redeposited in the systematic chapters of the book.

A similar confusion between the methods which are suitable for an elementary text-book and those which are required in a work of reference is also to be found in some of the figures. For example, it would have been much more satisfactory if facsimile reproductions had been given of the apparatus used by Lavoisier for the decomposition of steam by iron, and by Dumas for determining the composition of water, instead of the simplified and modernised versions of the diagrams which are given on pages 130 and 134 of volume 1; these can be of no possible value except to a student in the first stages of his chemical education, when simplicity rather than detailed accuracy is perhaps necessary. The figures are, however, not a strong feature of the treatise; thus, in volume 1 a figure has been omitted on page 89, while on page 214 a block has been printed upside down. On page 607 a block of Iceland spar with strictly rectangular faces is made to show the double refraction of a black spot on a strip of white paper without producing any refraction at all of the paper which carries the spot; the trigonal axes on page 618 also give the impression of being rectangular, and the rhombohedron of Iceland spar on page 619 does not appear to have been drawn according to any recognisable crystallographic scheme. The diagrams of spectra would also have been of greater value if they had been plotted on a scale of wave-

lengths instead of on what appears to be the arbitrary scale of an instrument.

At the head of each section a quotation is given, and many of them are particularly apt and interesting; it is a pity that only the name of the author is given and that the system of references does not enable these quotations to be traced to their source. This difficulty arises also in other cases, e.g. on page 83, where half-a-dozen striking examples of the influence of impurities on the properties of metals are given with the name of the author but no reference to the place where the quotations may be found. The author has adopted an ingenious system of numbering separately the references to each section of perhaps half-a-dozen pages, so that no extensive re-numbering is required when additional references are inserted, and each section with its references is complete in itself; but even this excellent system has occasionally failed and most of the minor errors which have been detected in the earlier chapters have arisen in connexion with the misplaced numbering of the references. It is, however, necessary to enter a protest against the way in which, especially in the systematic portion of the book, a score or more of references are included under a single number. In the case of a student who wishes to consult the whole bibliography of a subject, no harm may be done by this system; but in the case of a chemist who wishes to look up quickly the original sources from which data have been quoted, this method of handling the references gives rise to much troublesome delay. To take only one example, on page 84, volume 2, a figure is given of an apparatus by F. P. Worley, and the text corresponding to this figure is close at hand at the foot of the page, but a careful inspection fails to reveal any number or sign with the help of which the reference to this work might be found among the two pages of closely printed references at the end of the section. The numbers which form a guide to the references are in any case not easy to find in a text-book which bristles with the subscript numbers of chemical formulæ and the superscript numbers of mathematical formulæ and equations; and it is necessary to go back to the top of page 83 and forward to page 85 in order to discover the numbers 30 and 31, with the help of which the reference to Worley's work is finally traced among the eleven references quoted under the number 30. If this system of quoting references is to be satisfactory, the reader should at least have the assurance that he will not have to go beyond the limits of a paragraph in order to find the number which will lead him to the reference.

A fault which appears for the first time in volume 2 is the introduction of abbreviations into the main portion of the text. These abbreviations may be in

place when dealing with tabular matter or in condensed abstracts; but it is very irritating to the reader to be pulled up in a purely narrative section by phrases such as "the liquid is conc. in salt-pans," or "the press. between the surfaces is normal." After such an experience the reader feels an unwonted thrill of gratitude to the Publication Committee of the Chemical Society, which does not even allow these abbreviations in the narrative portions of its abstracts. The saving of space which is achieved in this way is more than lost as the result of inserting the initials of every author even when the same author is mentioned half-a-dozen times in one paragraph. The main idea of quoting the initials of an author is probably correct, even if it appears somewhat superfluous in the case of giants such as Lavoisier and Priestley; but to repeat the initials over and over again, when the text makes it perfectly clear that the same author is being quoted, is a purism which might well be sacrificed, if only in order to find space to print in full the half-finished words which disfigure the second (but not the first) volume of the Treatise.

It will be seen that the criticisms given above refer mainly to the way in which the contents of the Treatise are presented, and not to the contents themselves. The reviewer, who spent some weeks of his vacation in mastering the contents of the two volumes before attempting to criticise them, would therefore like to conclude his comments by again expressing his amazement that a single chemist should have brought together so immense a store of information and have compiled a Treatise which every English chemist will desire to have on his shelves as a masterly guide to the literature of his science. A list of errors is being forwarded to the author.

### Physiology of Respiration.

*Respiration.* By Dr. J. S. Haldane. (Silliman Memorial Lectures.) Pp. xviii + 427. (Newhaven: Yale University Press; London: Oxford University Press, 1922.) 28s. net.

DR. J. S. HALDANE'S book is nominally a report of his Silliman lectures delivered at Newhaven; in reality it is an account of his life's work in physiology. No one who turns over the pages can be but impressed with the enormous advance which has been made in the physiology of respiration within the last thirty years, and the degree to which that advance has been due to Dr. Haldane's work and to the stimulating influence which he has wielded over the minds of others.

To those who teach physiology, the contents of the book are for the most part familiar ground. To such, the book at its lowest will form a convenient epitome

of Dr. Haldane's works within the limits of a single cover, but many will delight in reading it because in it they will find a more perfect picture of the genius of the author than is obtainable from the perusal of his works in a less consecutive form.

One of the interesting points which will probably strike the reader is the extent to which Dr. Haldane's discoveries in the realm of pure science have been the result of problems which have confronted him in the province of industrial or applied physiology.

Of industrial physiology—now so recognised a branch of the subject in America—Dr. Haldane may almost be said to have been the founder in this country. More than thirty years ago the author was much concerned to arrive at some explanation of the fact that man could tolerate a concentration of carbon monoxide in mines which, according to what might be expected on theoretical grounds, should prove fatal. The difficulty so raised led to a complete investigation of the quantitative relations of the blood to oxygen and carbon monoxide respectively, and ultimately to his acceptance of the theory of pulmonary respiration put forward by Bohr, namely, that the pulmonary epithelium was capable of secreting oxygen (see chap. v.). It is not our object to discuss here the correctness or otherwise of these and other extremely controversial points in the book. Our concern is to point out that Dr. Haldane's refusal to leave an important point in the physiology of mines unexplained has led to a great volume of work both by himself and by others which, taken together, has given a quite unusual impulse to physiological research.

From chapters xi., xii., and xiii. it may be gleaned that in the 'nineties of last century and the early part of the present one, Haldane was much occupied with the analysis of mine air, of the air in tunnels, in ships, and in caissons. To the effects of sudden compression and decompression may probably be traced his interest in the effects of altered barometric pressure upon the human frame. The present volume facilitates the taste of the student who would acquaint himself with these problems, for hitherto much of its author's work on them has been hid away in blue books, mining reports, technical journals, and the like, so that it was difficult for the ordinary reader of physiological literature even to become appraised of its existence. In this connexion it is much to be regretted that the book lacks an index. If, as may confidently be expected, the present edition is followed at no great date by another, we hope that this omission will be made good. The book must surely be to a great extent a work of reference, and a book of reference without an index loses much of its usefulness.

The reader cannot scan the pages without observing

the large number of persons who have been privileged to collaborate with Dr. Haldane. To that company the book will mean something more than a mere recapitulation of his work or a history of the development and philosophic position, or a commentary on the action and reaction of abstract science on industrial research; it will mean something a little sacred, but something which one of them, at all events, finds some difficulty in putting into words.

JOSEPH BARCROFT.

### Our Bookshelf.

*An Introduction to Sedimentary Petrography: With special reference to loose Detrital Deposits and their Correlation by Petrographic Methods.* By Henry B. Milner. Pp. 125. (London: T. Murby and Co., 1922.) 8s. 6d. net.

THIS attractive little book deals mainly with loose detrital deposits and their correlation by petrographic methods. The first chapter gives an account of sampling, treatment, and methods of examination in about a dozen pages. The next chapter (56 pages) deals with detrital minerals and is illustrated by numerous plates showing the shapes and appearances of loose grains and crystals. Following this are two chapters in which a courageous effort is made to show the value of the evidence provided by detrital minerals as a means of stratigraphical correlation, and as an aid in palaeogeographical studies. A useful bibliography, a table showing the distribution of detrital minerals in British strata, and an index are included.

It is not easy to share Mr. Milner's confidence in the inferences he draws from the evidence provided by the mineral composition of sediments. Such evidence is rather unsafe as a basis of stratigraphical correlation, owing to the rarity and local significance of instances in which detrital minerals are derived from what he calls "homogeneous distributive provinces." The difficulty of generalising safely on the genesis of detritus is illustrated very forcefully by Mr. Milner's statement that a garnet-staurolite-kyanite suite suggests derivation from a definite thermo-metamorphic province, while a sphene-apatite-zircon assemblage is indicative of acid or intermediate rock-types as sources of supply, whereas an ilmenite-anatase-rutile-brookite association points to derivation from basic or ultrabasic rock-types.

These are, to say the least, highly controversial statements, but they tend to make the subject interesting and to stimulate further work; for, as Mr. Milner very properly remarks, the aim of science should be not merely to collect facts, but to explain them, and to put them to service in the solution of larger problems. The difficulty in this particular case is that the facts available are as yet scanty and very local in their significance. Much patient fact-collecting remains to be done before it can be ascertained whether any given system or series has definite characteristics as regards the nature and mineral composition of its detritus, and what those characteristics are. Not until this work has been done will it be safe to assert that the evidence provided by detrital minerals is useful in any substantial way as a basis of stratigraphical correlation.

T. C.

*Universal Problems.* By H. Jamyn Brooks. Pp. 123. (Braintree, Essex: The Author, The Limes, Shalford, 1922.)

REVIEW by quotation is not usually desirable, but with books of the class to which Mr. Brooks's belongs it is the only possible method. It will suffice to quote at random three of the eight "hypotheses on which the theories discussed in the work are founded."

"1. Every element, whether it be chemical, physical or mental, is distributed in unbroken unity throughout universal space."

"5. The mode of progression of the physical forces through matter and space is by communicated combustion, as is illustrated by the ignition of a train of gunpowder."

"7. Energy is the force which becomes manifest through expansion and contraction."

At first we are inclined to be amused, but really such books are tragic, not comic. For Mr. Brooks lacks neither intelligence nor enthusiasm. He has read enormously, and he has actually printed with his own hands the little book in which his views are presented. If only that intelligence and enthusiasm had been combined with the desire and the capacity to study science seriously! If only he had given to a few elementary text-books and a short course of laboratory work the time and application he has given to encyclopædia articles and "popular" treatises! Faced with such results as this, we are forced to ask ourselves whether the "popularisation" of science is all or mainly gain. Has Prof. Eddington, for example,—his book is quoted more frequently than any other—done good to science by arousing the interest of untrained readers, or harm by encouraging the delusion that they can really understand? N. R. C.

*Mechanical Testing: A Treatise in Two Volumes.* By R. G. Batson and J. H. Hyde. (Directly-Useful Technical Series.) Vol. 1: *Testing of Materials of Construction.* Pp. xiii+413. (London: Chapman and Hall, Ltd., 1922.) 21s. net.

THE contents of this volume deal with the testing of materials of construction; the testing of apparatus, machines, and structures will be included in the second volume. The authors have had extensive experience in the National Physical Laboratory, and this is reflected in their book. A large number of engineers in this country are now alive to the importance of continually testing the materials they employ, and to such the volume will be welcome on account of the information it contains regarding modern methods of testing. The student will also find the book useful, since no college laboratory contains all the apparatus described, and text-books on materials usually have only brief sections on the apparatus employed in testing. The greater part of the volume is devoted to the testing of metals; besides the ordinary simple commercial tests, we find chapters on the repetition of stress, combined stresses, hardness testing, impact testing, and the effects of temperature. The book closes with chapters on the tests of timber, stone, brick, concrete, road materials, limes, and cements. Sufficient information is given regarding the results of methods of testing to enable the experimenter to compare his own results with average values for trustworthy materials.

The book represents a large amount of work, not merely on account of its actual contents but also on account of the number of original papers which had to be consulted. This is evidenced by the copious references at the end of each chapter. The authors are to be congratulated on the success with which they have accomplished their task.

*Artificial Limbs and Amputation Stumps: A Practical Handbook.* By E. Muirhead Little. Pp. vii+319. (London: H. K. Lewis and Co., Ltd., 1922.) 18s. net.

No surgeon who may be called upon to amputate a limb can afford to disregard the problem of fitting a prosthetic appliance to the resulting stump. Mr. Muirhead Little has recorded his conclusions, based on a wide experience in fitting artificial limbs, and his book will undoubtedly take its place as a standard work of reference on the subject in English surgical literature.

The chapter on amputation stumps is of great importance; in it the author describes the characteristics of a good stump, the conditions which prevent or delay the fitting of prostheses, and the best methods of dealing with such conditions. The actual descriptions of artificial limbs are mainly those of the British Official Prostheses, *i.e.* appliances supplied by the Ministry of Pensions. Arms are classified according to the work required to be done, and again according to the amputation region. Lower limbs are grouped corresponding to the site and type of amputation. The book is very well illustrated and is complete in its attention to details outside the actual fitting of the limb, *e.g.* the preservation and repair of the artificial leg, and the re-education of the patient. The appendix contains specifications of artificial limbs, and directions for making certain sockets and for fitting the light metal leg.

*Industrial Nitrogen: The Principles and Methods of Nitrogen Fixation and the Industrial Applications of Nitrogen Products in the Manufacture of Explosives, Fertilizers, Dyes, etc.* By P. H. S. Kempton. (Pitman's Technical Primer Series.) Pp. xii+104. (London: Sir I. Pitman and Sons, Ltd., 1922.) 2s. 6d. net.

MR. KEMPTON has provided a very brief but readable account of an important industry which has grown up within the last ten years. The descriptions of the processes are necessarily very sketchy, but enough information is given to enable one to form a reasonably accurate picture of the present state of affairs—one which, it may be mentioned, is by no means to the credit of this country. Several minor inaccuracies were noted. The yields of the various arc furnaces given on p. 15 are not the real figures. The Claude process is not the only one largely used for the manufacture of nitrogen (p. 32). Copper formate, not chloride, is used for the purification of hydrogen in the Haber process (p. 45). "Rev. A. Milner, 1871" should be "Rev. I. Milner, 1788" (p. 64). The "Ostwald-Barton system" of ammonia oxidation (p. 67) is quite adequately described by the first of the two names, and the statement that in it "a catalyst of secret composition is used instead of platinum," although it appears to have been spread abroad for the information of the credulous, is wholly without foundation.

*The Beloved Ego: Foundations of the New Study of the Psyche.* By Dr. W. Stekel. Authorised Translation by Rosalie Gabler. Pp. xiv+237. (London: Kegan Paul, Trench, Trubner and Co., Ltd., 1921.) 6s. 6d. net.

DIFFERENT aspects of life, such as the fight of the sexes, psychic opium, the fear of joy, the unlucky dog, to select but a few, are some of the topics of the series of essays which constitute this book. Each chapter discusses special symptoms which, in particular cases, reveal that the personality has been thrown out of perspective, and the proffered solution is that love of the self is the fundamental cause of the disturbance. Love at first sight is love of the self as reflected in another, and even the person who is always disproportionately unlucky is so, because his self-love demands that he must be unique in some one direction. The author admits his indebtedness to the work of Freud, and regards it as a step towards a new psychotherapy, but believes that sexuality has been over-emphasised by Freud's followers. He aims at showing the part played by the self. The essays are in popular form and are certainly interesting and embody much sound advice.

*A Textbook of Organic Chemistry.* By Prof. J. S. Chamberlain. Pp. xliii+959. (London: G. Routledge and Sons, Ltd., 1922.) 16s. net.

PROF. CHAMBERLAIN'S textbook follows the usual lines. Only important compounds are described, and attention is directed to the general relationships between groups of compounds. The style is clear and the matter well arranged, so that students beginning the serious study of organic chemistry should find the book of value, especially if supplemented by lectures, as the author intended. The printing and paper are good. From the large number of elementary textbooks on organic chemistry which have appeared recently one might be led to infer that some new methods of teaching the subject had been evolved. This does not seem to be the case.

(1) *Industrial Motor Control: Direct Current.* By A. T. Dover. (Pitman's Technical Primer Series.) Pp. xi+116. (London: Sir I. Pitman and Sons, Ltd., 1922.) 2s. 6d. net.

(2) *Switching and Switchgear.* By H. E. Poole. (Pitman's Technical Primer Series.) Pp. ix+118. (London: Sir I. Pitman and Sons, Ltd., 1922.) 2s. 6d. net.

(3) *The Testing of Transformers and Alternating Current Machines.* By Dr. C. F. Smith. (Pitman's Technical Primer Series.) Pp. xi+91. (London: Sir I. Pitman and Sons, Ltd., 1922.) 2s. 6d. net.

(1) MR. DOVER'S object in his book is to discuss the principles involved in the starting and speed control of direct current motors. The principles are applied subsequently to typical control apparatus. The diagrams are well drawn and the descriptions are clear.

(2) The elementary considerations which have to be taken into account when designing apparatus for the switch-control of electric circuits are well described in Mr. Poole's book. It will form a useful introduction to more technical treatises.

(3) Dr. Smith's book will prove useful to students, and to engineers who want to revise their knowledge.

### Letters to the Editor.

[The Editor does not hold himself responsible for opinions expressed by his correspondents. Neither can he undertake to return, or to correspond with the writers of, rejected manuscripts intended for this or any other part of NATURE. No notice is taken of anonymous communications.]

#### Echinoderm Larvæ and their Bearing on Classification.

IN NATURE of December 22, 1921, Prof. E. W. MacBride, in consequence of Dr. F. A. Bather's review (in NATURE of December 8, 1921) of my work, "Studies of the Development and Larval Forms of Echinoderms," has taken the opportunity of making some remarks which, at least partly, have somewhat the character of a personal attack on me. Being at that time on a scientific expedition to the Malay Archipelago, it was not until the middle of May last that I received the issue of NATURE containing that communication. In spite of Dr. Bather's chivalrous defence on my behalf, I think it desirable to send to NATURE an answer to Prof. MacBride's letter. This could not possibly be done then, however, as out there (at the Kei Islands) I had no access whatever to literature—not even to my own work. I had to wait until my return from the expedition, and therefore it is only now that I am in a position to send a reply to the statements made by Prof. MacBride a year ago.

Prof. MacBride first emphatically objects to the idea that the metamorphosis of Echinoderms might be an alternation of generations. It is not quite clear to me whether this is addressed to the reviewer or to the author, or perhaps to both of us. Dr. Bather has replied for himself to this objection. I may be allowed here to reply to it for my part, and shall do so simply by quoting what I did write.

On p. 124 of my work I state that in *Ophiopluteus opulentus* the postero-lateral arms remain in connexion after the young Ophiuran has been dropped, in the same way as it occurs in the larva of *Ophiothrix fragilis*. In *Ophiopluteus opulentus*, however, it appears that the larva does not perish after a little while, as doubtless happens to the *Ophiothrix*-larva. Some specimens show that a new larval body begins to regenerate from the postero-lateral arms. That we have here to do not simply with abnormal larvæ is evident from the fact that the long postero-lateral arms are perfectly normally developed, which could not be the case in an abnormal larva with the mouth and intestinal organs imperfectly developed, and accordingly unable to feed. Further, on p. 148 is said: "How far the process of regeneration goes cannot be ascertained; but in any case Pl. XX. Fig. 5 shows that it may go on so far as till the formation of a new mouth and œsophagus. It is also evident from the numerous nuclei seen in the anterior part of the new body that a vigorous growth is going on here, so that it would seem most probable that the process may continue the short while, until the new digestive organs are able to assume normal function—and then there seems to be no reason to doubt that a new complete and ultimately metamorphosing larva may be the result. Thus we would here have a true case of metagenesis, otherwise totally unknown in Echinoderms." Finally, on p. 149 I have said: "Of course, I do not mean to maintain that definite proof of this astonishing regeneration has been given. But the available material certainly indicates that it does take place. The problem most urgently invites closer investigation."

I think it clear from these quotations that I do not

characterise the metamorphosis of Echinoderms as an alternation of generations. On the other hand, if the regenerating larva goes on to metamorphose a second time, even Prof. MacBride certainly will have to regard this as a (of course quite exceptional) case of metagenesis in Echinoderms. The correctness of my observations is not to be doubted—the regenerating larvæ are at the disposal of any one who may wish to control my figures; and my conclusions, which are perfectly logical, I cannot agree to be audacious.

To my statement that since the larvæ of the more primitive Asteroids (the Phanerozoia) are devoid of a Brachiolaria stage, the sucking disk found in the larvæ of *Spinulosa* and *Forcipulata* must be a later acquired specialised structure, and accordingly the homology generally supposed to exist between the sucking disk of the Brachiolaria and the Pelmatozoan stalk only apparent, and the great part it has played in phylogenetic speculations unjustified, Prof. MacBride most emphatically objects: "No more rash statement could be made nor one more devoid of foundation. Modern Asteroids are divided into five groups, viz. *Forcipulata*, *Valvata*, *Velata*, *Paxillosa*, and *Spinulosa*. Nothing whatever is known of the development of any valvate or velate form, but the fixed stage is found not only in the development of the *Forcipulata* (which Dr. Mortensen arbitrarily regards as the most specialised forms) but also in the development of the *Spinulosa* (which all admit to be the most primitive group). In the *Paxillosa*, which include the British genera *Astropecten* and *Luidia*, and which, *mirabile dictu*, Dr. Mortensen appears to regard as primitive forms, the fixed stage is omitted. . . ."

I shall leave the strong expressions to Prof. MacBride and only comment upon his statement that "all admit" the *Spinulosa* to be the most primitive group of Asteroids.

Prof. MacBride will probably agree that among naturalists now living the following are the first authorities on Asteroids: W. K. Fisher, H. L. Clark, R. Koehler, and L. Döderlein. I have written to all of them, asking them to tell me (1) whether they have ever stated as their opinion that the *Spinulosa* are the most primitive Asteroids (I did not remember ever having met with such statements in their publications, but I might, of course, have been mistaken); (2) to inform me which group of starfishes they regard as the most primitive. All answered that they had never stated the *Spinulosa* to be the most primitive Asteroids. Prof. W. K. Fisher writes: "I think that the typical Phanerozoia such as the *Astropectinidae*, *Odontasteridae*, etc., are decidedly more primitive than the *Spinulosa*, meaning by that the *Asterinidae*, *Echinasteridae*, and *Solasteridae*, to mention three of the families." Dr. H. L. Clark writes that he agrees perfectly with me "in considering the *Astropectinidae* as essentially primitive, and the *Spinulosa* specialised." Prof. Koehler writes: "Je crois, comme vous, que les types les plus primitifs doivent être cherchés dans les formes voisines des *Astropectinidées*, telles que le genre *Hudsonaster* et d'autres genres très anciens." Prof. Döderlein writes that he regards the family *Asterinidae* as "die ursprünglichste aller Scestern-Familien." Among recent authorities on Asteroids, Döderlein thus is the only one who holds a similar view as to the classification of Asteroids as Prof. MacBride; but as he has never stated this opinion in any of his publications, neither Prof. MacBride nor I could possibly know anything thereof.

I may further mention that both Sladen and Ludwig, who, Prof. MacBride will probably agree, must also count as authorities on asteroid classification, likewise regard the Phanerozoia, not the

Spinulosa, as the more primitive. This opinion is also adopted by Hamann in "Bronn" and by Gregory in Ray Lankester's "Treatise on Zoology." Prof. MacBride alone, and, among late specialists in Asteroids, Perrier, have expressed the view that the Spinulosa are the more primitive of Asteroids. Is Prof. MacBride then not perhaps attaching somewhat too much value to his own opinion when he states that "all admit" the Spinulosa to be the most primitive group of Asteroids—with myself alone as an absurd exception?

The question which group of Asteroids is the most primitive may not yet be definitely solved. If, however,—as nearly all admit—the Astropectinid forms are the most primitive, the conclusion is inevitably that the Brachiolaria, occurring—so far as evidence goes—only in the more specialised groups, the Spinulosa and Forcipulata, is a specialised larval form and its sucking disk a specialised, later acquired structure. Then this sucking disk is not homologous with the crinoid stalk, and its use in phylogenetic speculations is unjustified.

To Prof. MacBride's suggestion that my views would have some more value if I "had worked out with thoroughness the complete life-history of any Echinoderm," and to his protest against "the idea that those interested in Echinoderms agree with the over-estimate of the importance of trifling peculiarities in the structure of pedicellariæ in which Dr. Mortensen indulges" Dr. Bather has already kindly replied. In order not to make this belated reply too lengthy I shall then not take up these challenges at present.

TH. MORTENSEN.  
Zoological Museum, Copenhagen.

November 22.

### Rotary Polarisation of Light.

In the second edition of Dr. Tutton's monumental work on "Crystallography and Practical Crystal Measurement," a question of some interest to crystallographers and physicists is raised in an acute form by a footnote at the bottom of page 1082, which reads:—

"Considerable confusion has been introduced into the subject of optical rotation by the fact that chemists, in their use of the polarimeter for the determination of the rotation of the plane of polarisation by optically active substances (chiefly liquids or solids in solution, but occasionally the solids themselves), have adopted a different convention, as regards the sign of the rotation, to that employed by physicists and crystallographers, who refer to the actual occurrence in the crystal itself. For instance, the right-handed quartz of the crystallographer actually rotates the plane of polarisation of light in the opposite direction to the so-called dextro-camphor of the chemist. The latter regards a rotation as right-handed or dextro when it appears clockwise to the observer looking through the eyepiece of the polarimeter. But the crystallographer regards himself as travelling with the beam of light, that is, as looking along the direction of propagation of the light: if the movement of the light in the crystal is like that of a right-handed screw, clockwise, the crystal is right-handed or dextro-gyrotary, and if the light moves in left-handed screw fashion, anticlockwise, the crystal is lævo-rotatory or left-handed. It is very important that this should be quite clear."

This question as to the precise meaning to be attached to the words "right-handed rotation" has been responsible for a certain amount of misunderstanding and confusion in text-books on mineralogy and physics for nearly a hundred years, and from Dr.

Tutton's footnote it would appear that it is still unsettled.

Now the facts are simple. In 1813, the famous physicist Biot read a paper before the Institute of France<sup>1</sup> in which he described a number of experiments that he had made upon plates of rock-crystal cut perpendicularly to the axis of crystallisation. In carrying out this work Biot made the important discovery that there are two kinds of quartz—one in which the plane of polarisation is rotated to the right, while in the other the rotation is to the left. In carrying out these experiments Biot used a table polariscope, and adopting as a standard succession of colours that in which they ascend in Newton's scale, namely, red through yellow and green to blue, he found that a rotation of the analyser from left to right, that is in a clockwise direction, gave the standard succession for one kind of quartz, while an opposite rotation gave it for the other. The first rotation he spoke of as right-handed and the second, consequently, as left-handed. The experiments were subsequently carried out upon a considerable number of liquids and the convention of direction of rotation referred to was applied consistently.

In 1820, that is, seven years after Biot's discovery of right- and left-handed rotation of the plane of polarisation, Herschel read a paper before the Cambridge Philosophical Society<sup>2</sup> in which he announced his discovery that the direction of rotation of the plane of polarisation in quartz is indicated by the disposition of certain crystal faces.

Unfortunately, however, Herschel was not satisfied with Biot's convention, and he proposed to substitute for it one in which the observer was supposed to be looking along the beam of light in the direction in which the light was passing. While Biot, as it were, looked at an internally illuminated clock-face from the outside, Herschel preferred to look at it from the inside. Biot's right-handed thus became Herschel's left-handed rotation. Herschel, however, was consistent. He called the crystal which gave a right-handed rotation according to his convention, a right-hand crystal, and in giving the results of Biot's experiments on liquids, he changed the signs in order to bring them into accordance with his own convention. Thus according to Herschel cane sugar in solution rotates the plane of polarisation to the left.

Fig. 1 is a reproduction of the figure given in Herschel's original paper and reproduced in the article "Light" in the Encyclopædia Metropolitana (1830). In this article it is stated that the figure "represents a right-hand crystal." It is important to note here that in practically all modern books this figure illustrates a left-hand [twin] crystal. The confusion resulting from Herschel's attempt to substitute his convention for that of Biot was soon apparent.

In 1843 a book entitled "Lectures on Polarised Light delivered before the Pharmaceutical Society of Great Britain" appeared. This admirable little book of some hundred pages was written by Dr. Pereira. Now Dr. Pereira was evidently alive to

<sup>1</sup> "Mémoires de la classe des Sciences mathématiques et physiques de l'Institut Impérial de France (Année 1813)," Pt. I. pp. 263-4.  
<sup>2</sup> Trans. Cam. Phil. Soc., vol. I. p. 43 (1821).

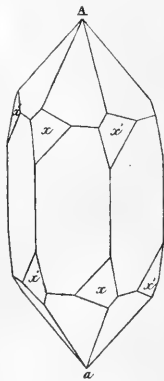

FIG. 1.—A right-hand crystal (Herschel).

the danger of confusion arising from the existence of contradictory conventions such as those of Biot and Herschel, because, on page 86, he writes:—

"There are two varieties or kinds of circularly polarised light which have been respectively distinguished by the names of dextrogyrate or right-handed, and levogyrate or left-handed.

"In one of these the vibrations are formed in an opposite direction to those in the other. Unfortunately, however, writers are not agreed on the application of these terms; and thus the polarisation, called, by Biot, right-handed, is termed, by Herschel, left-handed, and vice versa. There is, however, no difference as to the facts, but merely as to their designation. If, on turning the analysing prism or tourmaline from left to right, the colours descend in Newton's scale, that is, succeed each other in this order—red, orange, yellow, green, blue, indigo, and violet, Biot designates the polarisation as right-handed, or +, or  $\nearrow$ ; whereas if they descend in the scale by turning the analyser from right to left, he terms it left-handed, or -, or  $\searrow$ .

Sir John Herschel, on the other hand, supposes the observer to look in the direction of the ray's motion. Let the reader, he observes, 'take a common corkscrew, and holding it with the head towards him, let him use it in the usual manner, as if to penetrate a cork. The head will then turn the same way with the plane of polarisation as a ray in its progress from the spectator through a right-handed crystal may be conceived to do. If the thread of the corkscrew were reversed, or what is termed a left-handed thread, then the motion of the head, as the instrument advanced, would represent that of the plane of polarisation in a left-handed specimen of rock-crystal.'

"I shall adopt Biot's nomenclature, and designate the polarisation right-handed or left-handed according as we have to turn the analysing prism to the right or to the left to obtain the colours in the descending order."

We have in these paragraphs a very clear and unambiguous statement of the two conventions. Biot's is finally adopted and used consistently throughout the book. It will be noted, however, that Pereira speaks of colours which succeed each other in the order, red, orange, yellow, etc., as descending in Newton's scale.

A second and greatly enlarged edition of Pereira's book, edited by the Reverend Baden Powell, appeared in 1854, after the author's death. In this edition the above paragraphs remain substantially the same, except that the words "the colours descend in Newton's scale, that is, succeed each other in this order, red, orange, yellow, green, blue, indigo, and violet," in the first edition, are replaced by these words in the second edition (see p. 253)—"The colours descend in the order of Newton's scale—that is, succeed each other in the order of the colours of their plates, reckoning from the central black as the highest point."

It will be noticed that the enumeration of the colours, red, orange, yellow, etc., has been replaced by the words "succeed each other in the order of the colours of their plates, reckoning from the central black as the highest point," so that we must seek further for information as to the meaning of the words "descend in the order of Newton's scale" as used in the second edition. And turning to page 256, we read:—

"Thus, suppose we turn the analyser right-handed, that is, as we screw up, the colours succeed each other, with a certain thickness of the crystal, in this order—red, orange, yellow, green, purple, red again, and so on, in the ascending order of Newton's scale, on the colours of thin plates, before given."

So that in the second and first editions, the word "descend" has contradictory and opposite meanings. In the first edition it refers to colours succeeding one another in the order, red, yellow, green, and blue, whereas in the second edition the word "ascending" is used to denote the same order of colours. The result is that while Biot's convention was given clearly and correctly in the first edition, and used consistently, that given as Biot's convention in the second edition is, unfortunately, not Biot's but Herschel's convention, but both are used, with the result that the student gets hopelessly puzzled.

In Dr. Tutton's book, in spite of the warning in the footnote quoted, the first and also the second editions have apparently been written consistently with the Biot convention. In the first edition, for example, at pp. 802-803 and in the second edition at pp. 1082-1083, it is stated that "a slight rotation of the analyser from the position for the violet transition tint, to the right (clockwise) or left (anti-clockwise) according as the crystal is right-handed or left-handed, causes the colour to change to red (first order). On the other hand, a rotation of the analyser contrary to the rotary character of the plates causes the violet transition tint to change to blue or green (second order)." This statement, it will be seen upon consideration, can only be true of the right- and left-handed crystals shown by Figs. 344 and 345

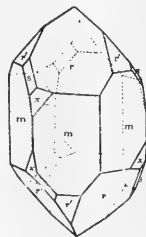

FIG. 344.—Left-Handed Crystal of Quartz.

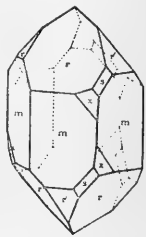

FIG. 345.—Right-Handed Crystal of Quartz.

FIG. 2.

of the first edition (here reproduced in Fig. 2) and Figs. 311-312 of the second edition, upon Biot's convention. Upon Herschel's convention the words "right (clockwise)" and "left (anti-clockwise)" should be transposed in the above quotation.

Any attempt to revive Herschel's convention should, I think, be resisted. Simple experimental facts should be capable of description in clear and unambiguous language, and this, as has been shown, is not likely to be achieved so long as two conventions, in such a simple matter, are tolerated. The fact that Herschel himself brought his convention into line with crystallographic nomenclature by calling what is now universally accepted as a right-hand crystal, a left-hand crystal, has been overlooked. The crystallographic conceptions of right- and left-handed crystals are not likely to be changed now, so that the adoption of the Herschel convention by any writer will, or should, necessitate the definite statement that according to this convention a right-hand crystal is made up of left-hand quartz. Dana, it is true, in his "System of Mineralogy" gives Herschel's convention, but he accepts at the same time the usual definition of right- and left-hand crystals, so that a right-hand crystal, according to him, is left-hand optically. It should be remembered, however, that the last edition of Dana appeared thirty years ago. Later writers such as Miers, Johannsen, Duparc, and Pearce, and many



others, have not, however, followed Dana—a crystal right-hand crystallographically, is also right-hand optically with them. F. CHESHIRE.

Imperial College of Science,  
South Kensington,  
October 27.

I AM much indebted to Prof. Cheshire for stating so clearly the historic incidence of the confusion which has arisen in regard to the designation of the two types of optical rotation, as to which shall be called right-handed and which left-handed, due largely to the reversal of Biot's convention by Sir John Herschel, and to the similar reversion in the second edition of Dr. Pereira's book. Other investigators and experimenters have also adopted the reversal, for instance, Sir William Spottiswoode at the time he was president of the Royal Society, for on pp. 47-48 of his book, "Polarisation of Light," we read: "A right-handed ray is one in which, to a person looking in the direction in which the light is moving, the plane of vibration appears turned in the same sense as the hands of a watch." Moreover, if instead of using the polariscope as a table instrument one projects the phenomena on the screen, the picture there displayed is reversed exactly like a lantern slide, which has to be inverted in the lantern (the two spots in front at the top being brought to the bottom at the back), in order to get an upright picture on the screen. Thus, for example, in the mica-sector experiment of the late Prof. S. P. Thompson (pp. 1103-1104 of the second edition of my "Crystallography and Practical Crystal Measurement"), the black cross moves on the screen one sector to the left for a right-handed quartz crystal and to the right for a left-handed one; whereas on looking through the same instrument used as a table polariscope the movement is to the right for a right-handed crystal, in accordance with the Biot convention.

It is thus important to know the exact conditions of the experiment whenever the question of the correct discrimination of right- or left-handedness in the optical rotation of crystals is being dealt with. Further, the safest course, in the case of quartz, is to cut the section-plate to be used to afford the definite decision from a crystal which is clearly a single individual, and not a twin, showing the little  $s$  and  $x$  faces unmistakably, and this course was pursued by me in the preparation of my "Crystallography." As most in accordance with current practice (that of von Groth and Pockels, for example), and in rightful deference to Biot, the discoverer of the two optically active kinds of quartz, Biot's convention was used, in both editions of the book, a course which it is satisfactory to learn meets with the approval of Prof. Cheshire. The apparent opposite, on p. 1101, lines 7-8, is due to this being a projection experiment, the observer looking towards the screen along with the light rays; the direction here, however, really does not matter, as only the colour of the centre of the field is being referred to; even here, perhaps, it would be better in any future edition (they were not present in the first edition) to omit the words "from the point of view of the observer looking in the same direction as the light is being propagated," the text then conforming clearly with the Biot convention. On p. 1083, where a table experiment is being referred to, and the conditions are otherwise similar to those in the centre of the field in the case just referred to, there is no ambiguity, the Biot convention being clearly followed.

It was felt desirable to direct attention to the confusion which has so obviously arisen, and this was done in the footnote to p. 1082. Emphasis was attempted to be laid on the fact that, after all, the phenomena are due to the passage of the ray through the helical structure of the crystal, now so happily confirmed by Sir William Bragg's X-ray analysis of quartz, and that the observer does well to imagine himself travelling with the rays through the screw, in order to appreciate the cause of the rotation of the plane of polarisation or vibration of the light rays. The particular screw type, right- or left-handed, is the same, however, whether we regard the screw from one end of it or the other, whether we look along with or against the light stream; otherwise it would matter which side up the quartz plate were arranged, that is, which side were placed the nearer to any particular one of the nicols. But the optical effect, the rotation of the plane of polarisation or of vibration of the light rays, is, of course, what matters and what is so clearly different for the two different types of quartz helices, and it was my intention to retain and use the Biot convention for its directional (right- or left-handed) designation. The footnote in question is not sufficiently explicit, and must be amended in any future edition. Prof. Cheshire and the writer are, however, quite agreed on the facts, and that this Biot convention shall be the one employed, and I am grateful to Prof. Cheshire and to the editor of NATURE for affording me the opportunity of stating this. A. E. H. TUTTON.

#### Space-Time Geodesics.

IN his letter in NATURE of November 25, replying to mine which appeared in NATURE of October 28, Prof. Piaggio points out that the equations of Space-Time geodesics may be deduced by other methods than those of the calculus of variations, and suggests that, in some such way, it is possible to get over the difficulties to which I directed attention.

My criticism, however, was directed, not merely against the definition of Space-Time geodesics as *minimum lines*, but against all seeming definitions of them which start from ideas of measurement as a fundamental basis.

I must, however, in passing, warn my readers against what at first sight looks like a suggestion, though I have no doubt that it was not so intended by Prof. Piaggio, that Space-Time geodesics might be defined in terms of "the osculating plane."

If there were any strict analogy with the case of geodesics on surfaces in ordinary three-dimensional geometry, such an "osculating plane" would (apart from a line of intersection) have to lie in some mysterious region outside our Space-Time continuum altogether. Prof. Piaggio, however, I have no doubt, wishes to lay stress upon the equations he obtains.

I was of course aware that the equations of Space-Time geodesics could be arrived at by various analytical devices; but how much better off does this leave us? Consider, for example, the simple Space-Time analysis as given by Minkowski and see what it implies.

In the first place, it implies a set of co-ordinate axes  $x, y, z$ , and  $t$ , which are themselves *geodesics*.

How are these particular geodesics to be defined?

They cannot be defined as minimum lines, for they are not minimum lines; and we cannot use our co-ordinate system to define them, since we are now contemplating how the co-ordinate system can be set up.

In the second place, the co-ordinate axes are supposed to be *normal* to one another. How is this *normality* to be defined? It is to be remembered that *normality* in Space-Time theory is a wider conception than normality in ordinary geometry; since in the former we have lines which are "self-normal" (or what I have called "optical lines"), in addition to other rather curious features.

In the third place, the co-ordinate axes are supposed (if I may so express it), to be capable of graduation in equal parts. How is this graduation to be theoretically arrived at, and how are we to compare lengths, say along the axis of  $x$ , with lengths in some other direction?

It thus appears that we are reasoning in a circle if we attempt to give an analytical definition of Space-Time geodesics on such a basis.

The employment of generalised co-ordinates does not free us from difficulties, for, if it gets us out of one difficulty, it brings in another in its place.

Thus, for example, if the "graduations" were made according to arbitrary scales, the expression for the length of a Space-Time interval would contain functions the form of which would depend upon the arbitrary character of the scales employed.<sup>1</sup>

Again, if measurement of intervals be regarded as a fundamental conception, what is one to make of a case where

$$(x_1 - x_2)^2 + (y_1 - y_2)^2 + (z_1 - z_2)^2 - (t_1 - t_2)^2 = 0,$$

in which  $(x_1, y_1, z_1, t_1)$  and  $(x_2, y_2, z_2, t_2)$  are the co-ordinates of two Space-Time points?

It must not be supposed that in raising these objections to the ordinary methods of treating this subject I am concerned only with destructive criticism.

My own answers to these difficulties are to be found in my published work.

In conclusion, I must thank Mr. Rogers for his very interesting letter published in NATURE of November 25; which, however, does not call for any special reply.

ALFRED A. ROBB.

Cambridge, November 27.

### A New Type of Electrical Condenser.

SINCE an electrical condenser is a device for storing electricity, it follows that a secondary battery is a condenser—obviously of very large capacity as compared with the electrostatic type of condenser. Arguing from this point of view it appeared to the writer that, by a suitable arrangement of pasted lead grids immersed in dilute sulphuric acid and connected in circuit with an alternating current, it should be possible to obtain the characteristic effect of an electrical condenser, namely, a phase advance of the current relatively to the terminal potential difference.



FIG. 1.

A large number of tests have borne out this conclusion and it may be of interest to readers of NATURE to show an oscillogram of the effect (Fig. 1). The oscillogram was taken during a test on a cell consisting of grids

<sup>1</sup> This is the same sort of point which would arise, for instance, in thermodynamical theory by using some arbitrary scale of temperature instead of the thermodynamic scale.

pasted with red lead and immersed in dilute sulphuric acid. The temperature of the electrolyte was about 86° C., the frequency of supply was 3.5 cycles per second, the current density about 0.75 amperes per square inch of grid and the r.m.s. value of the terminal pressure was a little more than 2 volts. There was practically no gassing of the cell during the test.

If the fundamental of the potential wave is determined it will be seen that there is a large angle of phase advance of the current on the pressure. There is one other interesting point noticeable in the oscillogram, namely, the potential difference of the grids remains relatively very small during a large portion of the current wave. When the current wave has passed its maximum value the pressure quickly rises to a maximum and then falls to zero at about the same moment as the current reaches its zero value. The process is then repeated during the next half of the current wave.

T. F. WALL.

Edgar Allen Research Laboratory,  
The University, Sheffield, November 25.

[An engineering contributor to whom we have shown Dr. Walls' interesting letter writes: "It has been well known to electricians for the last thirty years that an electrolyte with metal plates in it will act as a condenser. These devices are called electrolytic condensers and are used in everyday work. They generally consist of aluminium plates immersed in an electrolyte, but iron plates in a solution of soda are sometimes used. They are useful for getting currents which lead in phase the supply voltage. Dr. Gunther Schulze carried out an extensive series of tests on electrolytic condensers at the Reichsanstalt in 1909. See *Elektrotechnik und Maschinenbau*, 'Kondensatoren Grober Kapazität' (vol. xxvii. p. 247, 1909)."—EDITOR, NATURE.]

### Sex of Irish Yew Trees.

AFTER extensive inquiry up and down the country, I have so far failed to come across any example of the Irish Yew bearing male flowers. All the trees examined in private gardens and in cemeteries and churchyards have been of the berry-bearing or female sex.

I have now a number of young plants raised from the berries of the Irish Yew (*Taxus fastigiata*) fertilised by pollen from the English variety (*Taxus baccata*). These show a graded series from the spreading English type to the erect Irish form.

Growth is so slow, however, that it will be some years before it will be possible to ascertain the sex of these plants; meanwhile, I should be glad to know through the readers of NATURE any case of a male Irish Yew.

If, as is believed, the Irish Yew trees now growing in England have all been propagated by cuttings from the mutational Irish form, which first appeared in Co. Fermanagh, Ireland, more than a hundred years ago, this would explain the fact that they are all of the female sex. On the other hand, it is desirable to ascertain whether any linkage originally existed between erect habit of growth and female-ness in the mutational Irish variety.

Further, if any male example of the Irish Yew can be discovered it would be desirable to test the effect of fertilising the female Irish Yew by Irish pollen.

C. J. BOND.

Fernshaw, Springfield Road, Leicester,  
November 28.

## The Physiography of the Coal-Swamps.<sup>1</sup>

By Prof. PERCY FRY KENDALL, M.Sc., F.G.S.

THE subject of Coal Measures geology has been discussed piecemeal in innumerable papers and memoirs, so that an inquirer may well be appalled at the mass of facts and of often conflicting deductions with which he is confronted. Indeed, it is surprising to discover how fundamental are some differences of opinion which exist.

Among the questions in the answer to which doctors have differed there is, I imagine, none more fundamental than this:

Were coal seams simple aggregations of plant remains swept together by the action of water—a process of accumulation which the learned call allochthony; more simply by drift; or were they formed, like peat, by the growth of vegetable material in its place—the process of autochthony?

I do not intend to labour the answer to this question. Categorical arguments in favour of the growth in place origin of the coal-forming vegetation are on record, and they have never been as categorically answered. Many arguments in favour of the drift theory seem to me clearly to have arisen from confusion between canal and true coal. This distinction is again fundamental. True coal-seams are characterised by:—

- (1) Wide extent.
- (2) Uniformity of thickness and character over extensive areas.
- (3) Freedom from intermingled detrital mineral matter.
- (4) Constant presence of a seat-earth or rootlet bed.
- (5) Entire absence of remains of aquatic animals within the seam.

Substitute affirmatives for negatives, and negatives for affirmatives, and the characteristics of canal are as truly set forth.

### THE ABERRATIONS OF COAL-SEAMS.

Having got our coal-swamp clothed with vegetation, and the coal-forming materials accumulating, let us next consider the various interruptions of continuity and the aberrations to which it is liable. These interferences may be either contemporaneous with the accumulation of the materials, or, as one may say, posthumous.

Prominent in the category of contemporary interferences must be put the phenomena of split-seams. A split-seam is the intercalation into the midst of the coal of a wedge of sandstone, shale, or the like, in such wise that the seam becomes subdivided by intervening strata into two or more seams. The most notable split-seam in Britain is the famous Staffordshire Thick Coal. Jukes showed that this magnificent seam, 40 feet thick at its maximum, is split up into a number of minor seams by wedges of sedimentary strata which aggregate, in a distance of  $4\frac{1}{2}$  miles, a thickness of 500 feet. The explanation offered by that sagacious student of coal, Bowman of Manchester, might find here a typical application. Bowman supposed that a local sag occurred in the floor of the coal-swamp, resulting in the drowning of the vegetation and inter-

rupting the formation of peat until the hollow was silted up and a new swamp flora re-established.

I now turn to a form of split-seam of extraordinary interest, which has received comparatively little attention from geologists though mining engineers must surely have a special comminatory formula to express their sentiments thereon. The first example that came under my notice was encountered in the eastern workings of the Middleton Main Seam, at Whitwood Colliery, near Wakefield. Thin intercalations of shale and other sedimentary materials, appearing at different horizons in the seam, were found to thicken gradually to the east concurrently with the gradual dwindling of the lower part of the seam. An exploration was then carried out. The bottom coal was followed, but it was found that though the underclay continued the coal disappeared, and was wholly lost for a short distance before it reappeared. The top coal rose over a steadily thickening shale parting, and disappeared into the roof of the workings, but boreholes proved that it was present above a parting which was, at the maximum, 29 feet thick. At the farther end of the heading the top coal came down and the integrity of the seam was restored. Two other transverse explorations have proved the same general arrangement on the same scale of magnitude and one or both margins have been traced for a long distance, enabling the interruption to be mapped continuously for about 8 or 9 miles and intermittently much further.

My first impression was that this was just a simple case of Bowman's "sag," until I observed that in every traverse the upper element of the seam was arched while the floor was flat.

Several analogous cases came under my notice before an explanation of this anomalous arching was reached. The explanation was found to lie essentially in the differential shrinkage undergone by peat-stuff in the process of forming coal, and, on the other hand, by any sand or mud which may have been deposited so as to replace a part of the peat.

Let us imagine a stream being diverted at flood time across a bed of peat and scooping out for itself a hollow channel which subsequently becomes filled with sediments, and afterwards the formation of peat continues, the peat plants creep out, and presently envelop the whole mass of sediments. When the beds consolidate there will obviously be very different contraction between the sands, muds, and the coal-stuff. The sands will scarcely contract at all, the muds will contract a good deal, the coal-stuff will contract very greatly.

Let us now return to the consideration of the plano-convex lens of "dirt" occupying a position between the upper and lower elements of the split-seam at Whitwood. On the sag explanation it should be convex downward, yet in this as in all other cases I have investigated, it is convex upward. The explanation is simple. Let us make our mental picture of the infilled channel in the peat a little more specific in detail. Let us suppose that the peat was 40 feet in thickness when the river commenced to cut its

<sup>1</sup> From the presidential address delivered to Section C (Geology) of the British Association at Hull on Sept. 8.

course across it; the channel we will say was, like most channels, deeper in the middle than at the sides, and in the middle actually cut through to the sea-earth. Then the channel silted up completely, so that a cast of its meandering course in sands or mud reaching 40 feet in thickness at the maximum, but much thinner at the margins, was formed; then the upper bed of peat formed to a further depth of 40 feet. The conversion of the peat into coal would reduce it to two beds, each, let us say, 2 feet in thickness at the maximum, enclosing the sediment with a proportionately smaller thickness in the eroded peat on either margin of the channel. The sedimentary mass would have the transverse section of a plano-convex lens, the convexity being downward, but when the peat under the edges of the sediment is condensed to one-twentieth of its original bulk the base becomes almost flat, and the unconsolidated mass of sediments adjusts itself thereto. Thus the curve, originally at the base of the mass, reproduces itself in the top of the mass, which was originally quite flat and now is curved. The lens of infilling has reversed its curvature.

When a seam is deeply eroded the only too familiar phenomenon of a "wash-out" is formed.

The most common abnormality is the occurrence of belts or patches of "proud coal" in which the seam swells up to twice or thrice its normal thickness—sometimes, though not always, by repetition of the whole seam or of the upper part, either by shearing or by overfolding.

It has been suggested that all the violent displacement and over-ridings are brought about by tectonic agency, and that they are thrust-planes. The localisation to a single stratigraphical plane should suffice to discredit this explanation. An amplification of the same explanation ascribes the displacements to a thrust with a movement from S.E. to N.W. and a common cause to the cleat or cleavage of the coal which is normally directed to the N.W. It suffices to refute this to remark that the wash-outs I have explored in the Yorkshire coalfield are aligned in four principal directions, so that if superposed they would give what may be called the Union Jack pattern, *i.e.* N.E.—S.W., N.W.—S.E., N.—S., and E.—W.

Moreover, if these so-called "wash-outs" are not due to the erosive effects of contemporaneous or sub-contemporaneous streams, but to flat-having faults, any coal displaced should be presently found again without any loss whatever. That swellings and duplications of the seam occur we have already noticed, and such phenomena have been pointed to as evidence that there is "no loss" of coal in connexion with the so-called wash-outs. But losses and the gains by duplication do not, in fact, balance. A simple and convincing case is a wash-out in a thin seam, in which, by taking measurements of the thickness of coal present and the breadth of the barren area, I have been able to show that a gap with no coal for 210 feet is compensated for by only 35 feet of excess on the margin.

#### SEISMIC PHENOMENA IN THE SEAMS.

While the displacements and duplications are totally unlike those produced by faults, there are cases in which the seam appears to have been subjected to

a stretching tension and to have broken under the strain. Along the zone of such a stretch great confusion is commonly found. Masses of sedimentary materials, of the coal seam, and slabs and seams of cannel commonly occur, besides a curious argillaceous substance unlike any natural rock with which I am acquainted. In its unstratified structurelessness it suggests a kind of consolidated sludge such as might be produced by violently stirring or shaking a quantity of not too liquid mud. Where the seam abuts against this stuff it presents usually a nearly vertical ragged edge, its bright and dull layers preserving their characteristics quite up to the contact.

The explanation I have offered is that all these disturbances which complicate the already complex features of wash-outs are the effect of the lurching of the soft alluvial materials by earthquake agency. Every predictable subterranean consequence of earthquake action upon unconsolidated alluvial deposits, such as the Coal Measures were, can be seen in the Yorkshire Coalfield. The lurchings, the rolling and heaving of sand-beds, the shaking to pulp of the muddy deposits, the rending and heaving of the peat, cracks in the peat, and cracks infilled with extraneous material passing through the strata; and lastly, though actually the first clue to the explanation, masses of sandstone in the form of inverted cones ("dog's-teeth," "paps," or "drops"), descending on to coal-seams, which I interpret as the deep-seated expression of the sand-blows that are the invariable accompaniments of earthquakes in alluvial tracts.

An earthquake sweeping across an alluvial plain beneath which lay a thick bed of water-charged peat overlain by laminated clay, and that in turn by sand and an upper layer of mud or clay, would throw the peat and its watery contents into a state of severe compression which would result in the bursting of the immediate cover of clay and the injection of water into the sand, and, probably, a large quantity of gas, converting it thus into quicksand. This in turn would eject water in the form of fountains through the upper muddy or silty stratum, producing sand-blows and craters on the surface. When the disturbance subsided sand would run back down the orifice into the funnel above the peat. These are the "drops." They are commonly flanged down the sides, showing that they were formed upon a line of crack. An earthquake not infrequently gives rise to permanent deformations of soft deposits either by the lurching of the surface and the production of permanent wrinkles, or by subterranean migration of quicksand so as to produce, here a sag or hollow, there a ridge or bombement. Mr. Myron Fuller's admirable account of the effects of the New Madrid earthquake of 1816 as observed one hundred years after the event, is full of the most interesting and suggestive observations, not the least so those upon the sand-blows and sand-filled fissures containing lignite—the sand having come up from a bed lying at a depth of not less than 80 feet—the elevated tracts, and the new lakes produced by subsidence.

#### THE "CLEAT" OR "SLYNES" OF COAL.

One feature of coal-seams I must discuss before I conclude, though it will not at first appear clear

that it can be brought within the title of this address—I allude to the cleavage or cleat or slynes of coal. If we look at a piece of coal this cleavage is very conspicuous, for, lying at right angles with the bedding, it gives the straight sides to the fragment. It is obviously not like the cleavage of slate, a *texture*, but it is a series of well-developed joints.

It is a vital element in the cleat problem that it is as well developed and as definite in direction in a flake of bright coal the  $\frac{1}{100}$ th of an inch in thickness as in a tree-trunk. While I was preparing this address I procured a slab of shale from the bed underlying the uppermost bed of the Millstone Grit. It bore numerous imprints of goniatites and a leaf of Cordaites, which, in its present condition of bright coal, varies in thickness from about  $\frac{1}{30}$ th down to  $\frac{1}{150}$ th of an inch in thickness. It is traversed by an even and regular cleat at intervals of about  $\frac{1}{100}$ th of an inch, disposed at an angle of about  $35^\circ$  to the length of the leaf. With great care it was possible to replace the slab in its original position and to determine the orientation of the cleat to be N.W.-S.E. This is not nearly the extreme of tenuity reached by well-cleated plant remains. I have specimens that are mere shiny films, and cannot, I should judge, exceed  $\frac{1}{300}$ th of an inch, yet they show well-defined and regular cleat. Further, it should be noted that the production of cleat was subsequent to the erosion of stream channels as well as to the production of phenomena on the margins of the wash-outs. Every pebble and flake of coal found in the displaced masses in these stream-casts has the cleat well developed, and in strict parallelism with the cleat of the adjacent undisturbed seam.

I have directed attention to the fact that cleat is quite independent of the joints traversing the shales and sandstones of the associated measures; whence I draw the inference that the cleat must have been produced prior to the jointing.

The reason for this early development of a joint system is easily found—the original peat, in passing into lignite, acquired a brittle consistency and a consequent disposition to joint. Indeed, the change of consistency is the effect of chemical change and loss, whereby the peat substance contracts. Hence when our Coal Measures were first laid down they would consist of a series of incoherent sands and muds, and this uncompacted condition may have persisted for a very long period, even surviving considerable tectonic disturbances. The peats, however, would be subject to changes entirely innate: the gradual loss of volatile constituents, or at least the resolution of the carbon compounds into new groupings and the conversion of the mother substance of the coal into lignite. In this condition the coal-substance would be brittle and liable to joint in response to the tensile strains set up by the contractility of the mass.

There are questions of very deep import concerned with the geographical direction of the cleat. The first reference to this interesting topic is, I believe, in a work, close upon a century old, by Edward Mammatt, entitled "Geological Facts to elucidate the Ashby-de-la-Zouch Coalfield," published in 1834. His fourth chapter, headed "On the polarity of the strata and the general law of their arrangement," contains these remarkable passages: "Polarity of the strata

is a subject which hitherto has not been much considered. The extraordinary uniformity in the direction of the slynes and of the partings of the rocky strata seems to have been determined by the operation of some law not yet understood. . . . Wherever these slynes appear, their direction is  $23^\circ$  West of North by the compass, whatever way the stratum may incline. The coal between them has an arrangement of lines all parallel to the slynes, by which it may be divided. This is called the *end of the coal*."

In a paper in the *Geological Magazine* I commented on the fact that little had been written on the subject of cleat since Jukes's "Manual of Geology" (1862), in which he quotes a Nottinghamshire miner's remark that the slyne faced "two o'clock sun, like as it does all over the world, as ever I heered on," a generalisation to be remembered.

John Phillips corroborates the statement so far as concerns the coalfields of Northumberland and Durham, where he says it "runs most generally to the north-west (true)." The same direction, he says, prevails in Yorkshire and Derbyshire and also in Lancashire.

I have suggested a reason why coal should acquire a joint system anterior to, and independent of, that of the associated measures, but, while providing a jointing-force, that theory furnishes no explanation of the directional tendency of the cleat. This tendency must have been supplied by some directive strain—not necessarily of great intensity, but continuous in its operation.

In 1914 and since I have collected a great body of data regarding the direction of the cleat in coals and lignites in many parts of the world.

Cleat observations in the Northern Hemisphere show an overwhelming preponderance of a N.W.-S.E. direction in coals and lignites of all ages from Carboniferous to Pleistocene and from regions so remote as Alaska, Spitsbergen, the Oxus, Nigeria, and China. This direction persists through every variety of tectonic relations, but seems most regular in the largest and least disturbed fields.

Jukes's miner's astonishing statement that "the slyne faces two o'clock sun . . . all over the world" involves more than is at first glance apparent, for, as a friend has pointed out, that two o'clock sun must shine from a quite different compass-bearing in the Northern and Southern Hemispheres. Yet the data I have collected confirms generally the miner's declaration in the Southern Hemisphere as well as the North, though exceptions occur that may possess a deep significance.

Many of the southern coals have no definite cleat, but in such as do display a regular system there is a distinct predominance of the N.E.-S.W. direction, which has a curious inverse relationship with the N.W.-S.E. direction of the Northern Hemisphere.

I feel persuaded that the cause will be found in some relation to influences, tidal or other, dependent upon the earth's planetary rôle.

There is a negative aspect of the cleat question which brings it more clearly within the ambit of an inquiry into the physiography of the coal-swamps. I allude to the absence of cleat that characterises anthracite the world over. Upon this absence of cleat are attendant features that have been regarded as indicative of conditions prevailing during the

formation of the coal, and hence clearly within my terms of reference.

In the Memoir of the Geological Survey on the Coals of South Wales, it is pointed out that the anthracite condition, instead of being accompanied by a high ash-content—which is what might be expected if the ash ratio were determined simply by the reduction in the non-ash—is shown statistically to bear the reverse relationship. That is, the more anthracitic the coal, the lower the ash. From this it is argued that the anthracites of South Wales were formed of plant-constituents different from those contributing to the steam and house coals. This proposition gains no support from the study of the plants found in the associated measures, nor does it explain why the coals of other fields, composed in their various parts of very diverse constituents, do not exhibit the anthracite phase. But the ash question needs to be approached from another point of view. The ash of coal may, as I have shown elsewhere, be composed of three entirely distinct and chemically different materials. There may be (1) the mineral substances belonging to the plant-tissues; then (2) any detrital mineral substances washed or blown into the area of growing peat; and, finally, the sparry minerals located in the lumen of the cleat.

As to the first, I have long considered that the coal was in large measure deprived by leaching of much of its mineral substances; it is otherwise difficult to account for the almost total absence of potash. The second—detrital matter—is probably present in some though not in all coals; the high percentage of aluminium silicate is probably of this origin. But the third constituent—the sparry matter—may, both on *a priori* grounds and upon direct evidence, be assigned a very important rôle in the production of the ashes in most coals. When a coal with a strongly developed cleat is examined in large masses it is at once seen that the cleat spaces are of quite sensible width, and

that they are occupied most commonly by a white crystalline deposit which may consist of either carbonate of iron or carbonate of lime, and there are also in many seams crystals of iron sulphide—either pyrites or marcasite. These sparry veins may be as much as  $\frac{1}{10}$  of an inch, or even more, in thickness, and they clearly constitute the principal contributors to the ash. It has been suggested that they are true components of the original peat, a proposition to which no botanist would assent, and it appears certain that the veins consist of material introduced by percolation from the overlying measures, subsequent to the production of the cleat. If that be so, it then will follow that the amount of the material present in coal must be in some direct proportion to the available cleat space, and if there is no cleat neither will there be any vein-stuff to contribute to the ash. It should be pointed out that ordinary bituminous coal broken into minute dice and washed so as to remove any heavy mineral particles is found to contain a percentage of ash quite comparable with that of an average anthracite. It is to be concluded, therefore, that the variations of the ash contents of a coal are no indication of the plant-constituent of the coal.

I have sought to show how the concept of the Coal Measures with their sandstones, shales, and coal-seams accords entirely with what we know of modern swamps and deltas, and that just as each Coal Measure fact finds its illustration in modern conditions, so we may, inverting the method of inquiry, say that no noteworthy features of the modern swamps fail to find their exemplification in the ancient.

Even what may seem the most daring of my propositions—the seismic origin of abnormal “wash-outs”—finds, I cannot doubt, a full justification in what has been seen in the Sylhet region by Mr. Oldham, and in the Mississippi valley by Mr. Fuller, or in what can be *inferred* as a necessary subterranean accompaniment of these surface signs of great earthquake convulsions.

### The Royal College of Science for Ireland.

THE scientific public cannot but feel grave concern that the Royal College of Science for Ireland is at present closed, and its students are scattered in temporary accommodation. All interested in applied science will realise that this is a serious state of affairs, both as regards Ireland's industrial prosperity and scientific progress.

The College was founded nearly sixty years ago. It came into existence in 1865 as the result of a Treasury Minute of that year, which converted an existing institution—the Museum of Irish Industry and Government School of Science applied to Mining and the Arts—into the Royal College of Science. Sir Robert Kane—well known as the author of “The Industrial Resources of Ireland”—was appointed its first Dean.

The College was at first housed in premises in St. Stephen's Green, and as early as 1869 it had earned considerable reputation for itself as a school of science. Thus, the Commission on Science and Art in Ireland, of which Huxley and Haughton were members, reported in that year, that—“In the Royal College of Science, Ireland possesses an institution which in the

number of its professorships and general course of study is more complete as a pure school of science than anything of the kind existing in England or Scotland.”

In its earlier years the College was under the administration of the Department of Science and Art; but in 1900 it was placed under the control of the newly created Department of Agriculture and Technical Instruction, a department which was largely the outcome of what was known as the Recess Committee, of which Sir Horace Plunkett was chairman and Mr. T. P. Gill secretary.

Under the enlightened administration of this Department, the College was greatly developed and extended, particularly in rendering it of more direct service to the industries and needs of the country. In the early days of the College, chief attention was devoted to such subjects as chemistry, physics, mathematics, geology, mining, engineering, and manufactures. Under the Department, however, not only were these activities extended, but also considerable developments were made in connexion with agriculture, which is the staple industry of the country.

With the expansion of the teaching of applied science on so wide a scale, the accommodation in the existing buildings rapidly became wholly inadequate. Accordingly, the provision of new quarters became imperative, and under Act of Parliament in 1903 a government grant was made for this purpose. The magnificent new buildings on the present site in Upper Merrion Street were thus made possible, and the foundation stone was laid by King Edward VII. in 1904. The buildings were opened by King George V. in July 1911, and in October of that year the College began work in its new laboratories.

The buildings (Fig. 1), which were designed by Sir Aston Webb, occupy three sides of a quadrangle, and the numerous laboratories and lecture-rooms are laid out in a manner leaving nothing to be desired. Neither care nor expense has been spared in making the build-

ing of the College to its new home, all the principal courses were extended to four years, an alteration which has been amply justified in the light of the results which have been attained. Broadly speaking, the curriculum is now arranged so that the first two years are devoted to work mainly of a mathematical and purely scientific character, while towards the end of the second year, and during the third and fourth years, attention is devoted largely to the applications of science, and to the professional aspects of the several subjects of study.

The courses in all cases involve very considerable use of laboratories and workshops, and close co-ordination between tuition in theory and laboratory work has been worked out carefully.

The work of the College is organised in three faculties—those of agriculture, applied chemistry, and

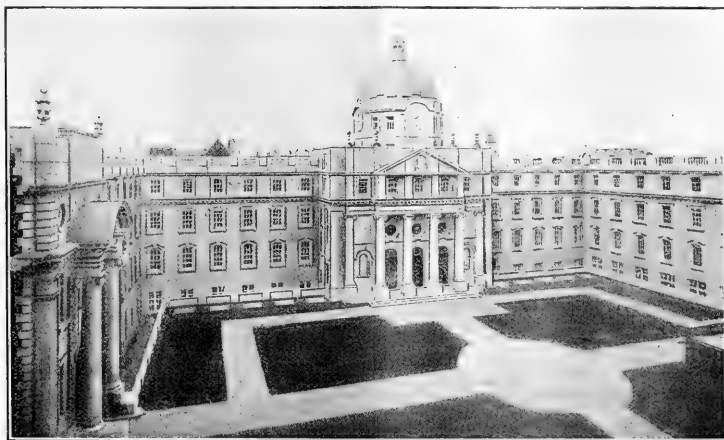

FIG. 1.—Royal College of Science for Ireland.

ings and equipment perfectly suited for the work of the College. Many years have been spent in their completion, and they are among the best in the British Isles at the present time. The laboratories are replete with the most modern appliances and accessories, and the machines and apparatus installed have been chosen for their excellence from the world's markets.

In short, the College possesses the great advantage that its buildings and equipment in every detail are up-to-date, and both have been thoroughly laid out with the definite object of providing the means necessary for dealing efficiently with the courses of education undertaken. The College buildings also provide laboratory accommodation for the important work of the Plant Diseases and Seed Testing Division, and the Agricultural Analytical Station of the Department of Agriculture.

For some time it had become apparent that the three-year course, which until 1911 had been required of the students taking the associateship, was inadequate to deal satisfactorily with a gradually extending curriculum. Accordingly, shortly after the removal

of engineering. In addition, there are four-year courses of study, in experimental science and in natural science, leading to industrial careers. The College also provides courses in science subjects for students who intend to become teachers in the technical and secondary schools of the country, and it is thus the keystone of the Department's scheme of technical and scientific education throughout Ireland.

Students who have successfully passed through one of the full courses of study are awarded the associateship of the College. Associates of at least three years' standing may proceed to the fellowship of the College, which is awarded for meritorious original scientific research or for contributing otherwise in a marked degree to the advancement of science.

There are professorships in agriculture, botany, chemistry, engineering, forestry, geology, mathematics, physics, and zoology; and lectureships in agricultural botany, agricultural chemistry, bacteriology, organic chemistry, physical and metallurgical chemistry, engineering, horticulture, mathematics, and physics. Among the past professors are many well-known names, such as—Sir Robert Ball, Sir William Barrett, Sir

William Thiselton Dyer, Dr. A. C. Haddon, Sir Walter Hartley, E. Hull, Dr. G. T. Morgan, T. F. Pigott, and Sir Wyville J. Thomson.

Following upon the establishment of the College in its new buildings, there has been a steady and progressive increase in the number of its students, and its several courses of study are becoming appreciated more and more fully throughout the whole of Ireland. Moreover, the past students have been winning success in the several fields of industry and education for which their courses have fitted them.

In the Faculty of Agriculture the scientific courses given at the College have been the basis of considerable improvement in agricultural practice in the country, for in the majority of cases the young Irishmen who have attended these courses at the College have found their way into the service of the Department of Agriculture as Agricultural Instructors, located in various rural districts, where they act as scientific advisers to the farmers. Others put their knowledge to account in the management of large farms and estates.

In the Faculty of Applied Chemistry many highly trained young men have been turned out and have found scope for their training as assistants and research workers in many chemical industries, such as the manufacture of dyes, explosives, and synthetic drugs.

In the Faculty of Engineering the increase in the number of students following upon the development of the new laboratories has been specially marked, and already the demands for admission are taxing the accommodation to its utmost. The majority of

these students find employment with the large engineering concerns in the British Isles; and prior to the present condition of depression, there was a regular demand each year for capable students from some of the leading establishments. The output of the engineering and chemistry departments of the College should be of great and essential service to Ireland, if a policy of industrial reconstruction is undertaken.

The equipment of the College is excellently suited for active research in many directions. Indeed, already after a few years' occupation of the new premises, upwards of one hundred researches were in hand or had been carried out, many of them being on subjects of direct benefit to the industries of Ireland. While research thus holds a high place in its activities, the College is, nevertheless, specially noted for the thorough attention that is devoted to the effective teaching of its students. Its success is due to the devotion and energetic service of its able staff, as much as to the modern conditions under which their labours are carried out.

It would not only be a national calamity but also a matter of the greatest concern to progress in applied science if this great institution, that has taken many years of devoted service of its staff to bring to its present high standard of excellence, should be rendered unavailable for the young men and women of Ireland. It is, therefore, greatly to be hoped that the present difficulty will be but a passing cloud, and that the College will soon be permitted to reopen its doors, and will find its true place in the industrial development of Ireland.

### Obituary.

SIR ISAAC BAYLEY BALFOUR, K.B.E., F.R.S.

ISAAC BAYLEY BALFOUR, son of the late Dr. John Hutton Balfour, professor of botany in the University of Edinburgh from 1845 to 1879, was born in Edinburgh on March 31, 1853. Educated at the Edinburgh Academy, then as now one of the foremost of British public schools, young Balfour proceeded to the University, in which he graduated as D.Sc. in the department (not yet a faculty) of physical and natural science. He also matriculated in the faculty of medicine, and while still an undergraduate in that faculty was so fortunate as to be attached to the party which in 1874 visited the island of Rodriguez to observe the transit of Venus.

Resuming his medical studies, Balfour graduated as M.B. with honours in 1877, and thereafter continued his botanical studies in the Universities of Strasbourg and Würzburg. In 1879 he was appointed professor of botany in the University of Glasgow, and in 1880 undertook botanical survey operations in the island of Socotra. In 1883 he obtained the degree of M.D., being awarded a University gold medal for his thesis, and in 1884 he was elected Sherardian professor of botany at Oxford and given charge of the Oxford Botanic Garden, becoming at the same time a fellow of Magdalen. In 1888 he was elected professor of botany in the University of Edinburgh, in succession to the late Dr. Alexander Dickson, and was appointed King's Botanist for Scotland and Regius Keeper of the Royal Botanic

Garden. From these posts Balfour retired in March last after having held them, as his father did, for a period of thirty-four years.

If Balfour, as regards youthful environment, was fortunately situated, he showed at an early age that he had made good use of his opportunities. In 1874 Dr. J. D. Hooker, then director of Kew, considered one of Balfour's letters from Rodriguez sufficiently interesting for communication to the Linnean Society. Among the results of this journey we owe to Balfour a finished study of the genus *Halophila* and an important contribution to the natural history of the difficult genus *Pandanus*. The elaboration of the material secured during his visit to Socotra involved sustained study for nearly eight years; the result was a work that has already become a floristic classic. But Balfour's systematic interest was equalled by that taken in economic questions, and his Socotran studies enabled him to determine the sources of more than one famous drug of which the geographical provenance was assured though the botanical origin was uncertain. From the outset of his career he realised the importance of historical study in the field of applied botany.

Short though Balfour's tenure of the Sherardian chair was, the success with which he discharged its duties led to results of permanent advantage to Oxford and to botany. Under his care the historic "Physick Garden" regained its old consequence. The part he played in the provision of an English version of De Bary's *Fungi, Mycetozoa, and Bacteria* earned for him



the thanks of English and American students, who owe him besides a debt for his share in the foundation of the *Annals of Botany*; from the outset he served as one of the editors of this successful and important journal.

It was, however, the work accomplished by him as a teacher for a generation at Edinburgh that led Balfour to be regarded, with justice, as one of the foremost of British botanists. His personal charm enabled him to arrest the attention of his students; the lucidity of his discourse ensured the maintenance of that attention. But the reality of his success depended neither upon these natural accidents nor upon the variety and the precision of the knowledge which informed his teaching. It is to be accounted for rather by the wide sympathy which enabled him, as one who was at once an erudite natural historian and an accomplished experimental biologist, to combine all that was valuable in the older training to which he had been subjected in this country and in the newer methods which he had mastered abroad. To a still greater degree, perhaps, he owed his success to that sane outlook which enabled him to induce those he taught to regard botanical investigation and research, in the field, the cabinet, and the laboratory alike, as means to an end rather than as ends in themselves.

Balfour's work as Regius Keeper and as King's Botanist was actuated by the same philosophy. His study of the natural history of the plants under his care, while complying with the highest standard set in ecological and in systematic work, was undertaken with the object of mastering their cultural requirements. The success of his results in the technical field was largely due to the thoroughness of his scientific study.

The long-sustained and critical investigation of the members of the two great genera, *Primula* and *Rhododendron*, to which of late years Balfour devoted much of his scanty leisure, has given his name a permanent place in the annals of systematic study. The complexity of the problems he has had to face might almost justify a suspicion that in Balfour's case the difficulty of a subject was an added incentive to its study. However this may be, the fact remains that these arduous labours, though incidentally of extreme taxonomic value, have had as their primary purpose the rendering of assistance to horticulture in dealing with the accessions of new plant-forms during the past two decades from south-western China and the north-eastern Himalaya. It is because the object of his studies was the provision of technical help to the gardener, and not in spite of that fact, that the results attained are of such benefit to students of plant-distribution and plant-association.

Among the extra-official duties undertaken by Balfour were included willing services rendered to the Edinburgh Botanical Society, the Royal Society of Edinburgh, and the Royal Horticultural Society. Elected to the Linnean Society in 1875, he served on the Council during 1884-85; elected to the Royal Society in 1884, he served on the Council during 1892-94. In 1894 he was president of the biology section of the British Association at the Oxford meeting, and in 1901 was president of the botany section at the Glasgow meeting. An invitation to serve as president of the Linnean Society, in succession to Prof. Poulton, in 1916 was declined, and the intimation that his health was such

as to preclude acceptance was one of the earliest to cause his friends disquietude.

In 1920 Balfour was created a K.B.E. in recognition of the great public services rendered by him during the war, his devotion to which had undermined his constitution. Among other honours bestowed on Balfour were the Victoria Medal of Honour of the Royal Horticultural Society, received in 1897, and the Linnean Medal—the highest honour the Linnean Society could offer—received in 1919. The wish then expressed by the latter society that Balfour "might long be spared to continue the work that has served its members as an example and an encouragement" has unfortunately not been fulfilled. By his death, which took place at Court Hill, Haslemere, on November 30 last, botanical science has lost a brilliant votary; his friends have lost one whose soundness of judgment was only equalled by his ready kindness and unflinching courtesy.

#### SIR NORMAN MOORE, BT., M.D.

THE medical profession is poorer by the death of Sir Norman Moore on November 30. Born in Manchester seventy-five years ago, he rose without influence and solely by his own exertions to be president of the Royal College of Physicians. He also earned a well-deserved reputation as an historian of British medicine. After a preliminary education at Owens College, he matriculated in the University of Cambridge from St. Catherine's College, whence in due course he graduated in arts and medicine, being afterwards elected an honorary fellow. He entered St. Bartholomew's Hospital in 1879 and remained in close association with it during the whole of the rest of his life. He served first as lecturer on comparative anatomy, later as demonstrator of morbid anatomy, and in due season as lecturer on medicine in the medical school, while in the hospital he filled in succession all the offices from house physician to consulting physician. He also acted for many years as dean of the school and warden of the college, living within the precincts of the hospital, and serving so zealously that for many years the annual entry of students exceeded that of any of the other hospitals in London.

During his years of residence in St. Bartholomew's Hospital, Moore laid the foundations of his renown as an historian of medicine. He wrote as many as 454 articles, dealing chiefly with the lives of medical men, for the "Dictionary of National Biography." He was instrumental in obtaining for the Royal College of Physicians the endowment of the FitzPatrick lectures, and himself gave two courses of the lectures, one on "John Mirfield and Medical Study in London during the Middle Ages," the other on "The History of the Study of Clinical Medicine in the British Isles." His knowledge of the subject and his work in connexion with it made him a worthy successor to Sir William Osler as president of the history section at the Royal Society of Medicine. More than thirty years of such time as he could spare from his other duties were devoted to the preparation of a history of St. Bartholomew's Hospital. The work was delayed by the war, but it appeared in two well-illustrated quarto volumes in 1918, and immediately became a classic.

The age and traditions of the Royal College of

Physicians appealed to Moore in the same way as did those of St. Bartholomew's Hospital. He filled all the usual posts with unflinching punctuality, was Harveian Librarian, and served in the office of president from 1918 to 1921. He was also the representative of the College at the General Medical Council. He had an intimate knowledge of the needs of medical education, and he took a leading part in that recasting of the medical curriculum which began in 1886 and is still in progress.

Moore's love of books and his knowledge of their

contents were utilised by the Royal Medical and Chirurgical Society, where he filled the post of honorary librarian for many years. When the society was merged in the present Royal Society of Medicine, Moore, in conjunction with Mr. Stephen Paget, wrote the chronicles of the society from 1805 to 1905, with some account of the presidents.

In 1919 Moore was created a baronet. He was twice married, and is succeeded by his surviving son, Alan Hilary.

### Current Topics and Events.

WHILE the rest of the world has been getting used to filling up the forms required by Customs authorities, and to awaiting with patience the delays involved in the examination by Customs laboratories of imported products that may prove to be dutiable, Great Britain has forgotten the very existence of such things, and their reintroduction, as a consequence of the Safeguarding of Industries Act, is regarded as little less than a revolutionary innovation by importers and their spokesmen in the House of Commons. It is clear from the debate which took place on Sir John Simon's amendment to the motion for an address in reply to the King's Speech, regretting the absence of any reference to the repeal of this Act, that opposition to the Act arises largely from its administration. Almost every speaker admitted the necessity of legislation to prevent the recurrence of the famine in magnetos, drugs, optical glass, dyes, and other essential commodities, which occurred in this country on the outbreak of war, but those who wished the Act repealed failed to mention a scheme by which this end could be achieved, probably because any attempt to do so would split up the apparently solid phalanx of opposition. To those who have the national welfare in mind, the troubles of Sir John Simon's trader, who had a consignment of potassium permanganate held up for two months by the Customs, will make slight appeal, and they would cheerfully see a few traders, who have no direct interest in industry and merely buy and sell, sacrificed, if by that means they could ensure the establishment in this country of highly technical industries in which skilled craftsmen and technical experts could be employed and the safety of the country in war and in peace assured. The difficulties which the operation of the Act places in the way of the importation of chemicals and instruments required by research workers, naturally evoke more sympathy than those of traders; and it is satisfactory that the Government was able to promise a joint inquiry by the Department of Scientific and Industrial Research and the Board of Trade into the progress actually made in the industries with which the Act is concerned. In the course of that inquiry these difficulties will no doubt be fully explored and means of dealing with them evolved.

THE needs of men of science in Russia have been referred to on several occasions in our columns, and we have suggested that the different groups of scientific and technical societies should concern

themselves with groups of workers in their own departments. This has, we believe, been done in connexion with the Committee for the Relief of Russian Intellectuals, the president of which is Sir Paul Vinogradoff. There is an Engineers' Section Sub-Committee, with Sir Robert Hadfield as president, and this sub-committee has just made an appeal on behalf of Russian engineers and their families, who, not alone in the famine areas but throughout Russia, are undergoing terrible suffering and distress. If British engineers will help, many lives can be saved and the human energy and knowledge necessary for the reconstruction of Russia can be retained. Assistance is required for the provision of food and clothing. Food parcels may be sent to particular individuals, or names and addresses can be supplied to donors who prefer to send parcels direct. Remittances should be sent to the honorary treasurer, Mr. R. C. Griffith, 8 Victoria Avenue, Bishopsgate, London, E.C.2, who will be glad to give any particulars desired.

A SCIENTIFIC novelties exhibition will be held at King's College, Strand, W.C. (by kind permission of the College delegacy), from December 28 to January 10, in support of the Hospitals of London Combined Appeal. Members of the scientific staffs of the various colleges and schools of the University of London, as well as of university institutions having recognised teachers, are assisting with exhibits or demonstrations, and short lectures with experimental or lantern illustrations will be given by Profs. Bairstow, Sir William Bragg, Cheshire, Winifred Cullis, Flinders Petrie, Garwood, Gordon, Macgregor-Morris, Watts, Wilson, and many others. The exhibition will not be merely a display of objects of interest, but of the character of a *conversazione*, in which experiments and demonstrations will be going on continuously. It will thus be attractive to both old and young, and we hope it will bring a substantial sum into the fund for which it is being organised.

THE issue of *La Nature* for November 18 contains a summary of the recent International Congress on Combustible Liquids held in Paris under the auspices of the French Society of Chemical Industry. Prior to the opening of the congress, an exhibition was organised in which practically every phase of the petroleum and allied industries received attention. The several stages in the production and refining of crude oil were amply illustrated by an excellent

series of exhibits, including not only the various products manufactured, but also the plant and machinery employed both in the field and in the refinery. A special feature was the exhibition of different types of internal combustion engines in actual operation, burning those grades of fuel most suited to particular designs. The congress was opened by Prof. Sabatier, and the business transacted was of a most comprehensive nature, the industry being considered in both its theoretical and practical aspects. Undoubtedly the most important question raised at this congress was that of the necessity of adopting a uniform terminology to cover the enormous variety of combustible liquids now being marketed. At the present time the utmost confusion reigns in many cases where a name for a given product in one country implies a totally different product in another. Further, the varied methods adopted of testing these products for definite commercial purposes are often productive of results which, while suitable for one country, are quite ineffective for another. In order, therefore, to standardise both methods of comparison and the nomenclature universally applicable to definite products for specific purposes, an international commission has been set up, composed of delegates of the several countries represented at the congress. The importance of this work cannot be overestimated, particularly from the point of view of European markets, though it is to be hoped that representatives of the American petroleum industry will take a prominent part in the framing of the ultimate standards adopted.

DR. J. WALTER FEWKES, chief of the Bureau of American Ethnology, Smithsonian Institution, has recently returned to Washington from the season's archaeological field-work on the Mesa Verde National Park, Colorado, and reports the unexpected find of an interesting prehistoric ruin to which he has given the name, "Pipe Shrine House." A mound of some magnitude in the neighbourhood of a reservoir called Mummy Lake was investigated, and a rectangular building about 70 feet square and one story high, which is accurately oriented to the cardinal points, and has a circular tower formerly 15 to 20 feet high, like a church steeple, midway in the western wall, was discovered. The tower was probably used for observing the sun as it rises in the east or sets in the west, in order to determine the time for planting and other events. In the middle of the building was found a circular room twenty feet deep and about the same in diameter in which were more than a dozen clay tobacco pipes, numerous stone knives, pottery, idols, and other objects. Pipes of this kind have never before been found on the Mesa Verde National Park; apparently after the rite of smoking they were thrown into the shrine. South of the building, which was evidently specialised for ceremonials, is a square room or shrine dedicated to the mountain lion, a stone image of which was found surrounded by water-worn and other strangely formed stones. A similar shrine in the north-east corner of Pipe Shrine House contains a small iron meteorite and a slab of stone on which is depicted the symbol of the sun.

THE juvenile lectures at the Royal Institution this Christmas will be delivered by Prof. H. H. Turner, whose subject is "Six Steps up the Ladder to the Stars." The first lecture will be given on Thursday, December 28, on "The Distance of the Stars," followed by "The Discovery of the Planet Neptune," "Photographing the Stars," "The Spectroscope and its Revelations," "Two Great Streams of Stars," and "The Size of a Star." The following are the lecture arrangements before Easter: On Tuesday afternoons, commencing January 16, there will be two lectures by Prof. F. G. Donnan on "Semi-Permeable Membranes and Colloid Chemistry," two by Mr. R. D. Oldham on "Earthquakes," two by Prof. A. C. Pearson on "Greek Civilisation and To-day," two by Sir Arthur Shipley on "Life and its Rhythms," and two by Prof. C. G. Seligman on "Rainmakers and Divine Kings of the Nile Valley." On Thursday afternoons, the Hon. J. W. Fortescue will give two historical lectures beginning on January 18, Prof. I. M. Heilbron two on "The Photosynthesis of Plant Products," Prof. B. Melville Jones two on "Recent Experiments in Aerial Surveying," and Mr. Theodore Stevens two on "Water Power of the Empire." On Saturday afternoons commencing January 20, there will be two lectures by Sir Walford Davies on "Speech Rhythm in Vocal Music," two by Mr. J. C. Squire on "Subject in Poetry," and six by Sir Ernest Rutherford on "Atomic Projectiles and their Properties." The first Friday evening discourse will be delivered by Sir James Dewar on January 19 on "Soap Films as Detectors of Stream Lines, Vortex Motion and Sound." Succeeding discourses will probably be given by Sir Almoth Wright, Mr. C. F. Cross, Sir John Russell, Dr. A. V. Hill, Prof. A. S. Eddington, Dr. G. C. Simpson, Dr. M. R. James, and Sir Ernest Rutherford.

THE Journal of the Textile Institute has now nearly completed its first year under the new arrangement by which its pages are separately arranged and numbered under the three headings of Proceedings, Transactions, and Abstracts. The new form of the Journal should appeal to a wide scientific public, and the attention of biologists interested in the raw materials of plant or animal fibre may be directed to the very wide field covered by the abstractors and to the scientific character of the papers appearing in the Transactions. The Journal is now the medium through which a considerable amount of the scientific work carried on by the research associations of the woollen and worsted, the cotton and the linen industries, first sees the light. These newly formed research associations have naturally been busy surveying their wide fields for future effort, and the result has been that a number of very useful general summaries of the state of our knowledge of the chemistry, physics, and botany of the cotton hair have been published in the Journal by members of the staff of the British Cotton Industry Research Association. Preliminary results of new investigations upon the plant fibre also begin to appear, as, for example, the two papers by C. R. Nodder upon plant fibres, dealing mainly with flax and hemp.

ACCORDING to the last monthly circular of the British Cast Iron Research Association, the new director of research, Dr. P. Longmuir, is now formulating a scheme for the active prosecution of research work in several directions. Among the subjects now in hand are: iron suitable for moulds for glass bottles, these moulds being at present largely imported from abroad; and the magnetic properties of cast iron. The high silicon irons now found so useful in chemical industry on account of their high resistance to mineral acids are also to be investigated. Together with the American Testing Society, the question of the standardisation of cast-iron test bars is being examined, and it is hoped that an international specification can be devised. The Association is strengthening its library and reference facilities, and should appeal to a wider circle of ironfounders than its present rather limited membership, in view of the importance of cast iron to the national industries.

In the Proceedings of the Royal Society of Edinburgh (June 1922) the general secretary—the late Dr. C. G. Knott—gives some interesting notes of a correspondence between the Royal Society of Edinburgh and the French Academy of Sciences about the priority of the discovery of the pilot cable (*câble guide*) for guiding ships into harbour in foggy weather. In 1921 the French Academy awarded a medal and a prize to W. A. Loth for various devices in connexion with navigation, and among these was the *câble guide*. The principle of this device, the Edinburgh Society states, is essentially that of the pilot cable invented by C. A. Stevenson and described by him in the *Journal of the Society* in 1893. Mr. Stevenson's invention consists in laying a wire or wires along the bed of the sea or of a river. Intermittent currents are sent along these wires, and suitable devices can be used on board ship to detect their proximity, and thus receive a warning of dangerous coasts, shoals, and so on. Stevenson's patent proves that the rough general principle was known so early as 1891, but this does not detract from the credit due to Loth for perfecting the system. The principle of the method is identical with that used by electricians in London prior to 1890 for locating the position of an underground cable.

A CHADWICK public lecture on "Relative Values in Public Health" was delivered by Sir Arthur Newsholme, on December 7. In the course of his lecture, which is one of a course, Sir Arthur Newsholme, after deprecating the indiscriminating call for retrenchment in public health expenditure, stated that it is necessary to adopt every practicable measure for educating the public, and the first step is to educate people as to the causes of evils. Historically, panic—fear of cholera and "fever"—had facilitated sanitation. In Sir Arthur's opinion, the appointment of paid inspectorates, thus introducing a new element into the implements of government, is necessary. Inspection has increased, extending from things and conditions of work and housing of persons, until we have now in view the ideal of hygiene advice and warning available for every member of the com-

munity. The inspections have educational value even more than in securing reform. Surveys are extended and systematised inspections, and are of value in arousing the community conscience and in securing the driving power needed for reform.

SIR WILLIAM H. BRAGG, Quain professor of physics in the University of London, has been elected a corresponding member of the Paris Academy of Sciences in the section of physics.

THE library of the Chemical Society will be closed for the Christmas Holidays at 1 P.M. on Friday, December 22, and will reopen at 10 A.M. on Thursday, December 28.

THE Indian Botanical Society took over ownership and control of the *Journal of Indian Botany* in October (1922). Prof. P. F. Fyson, who started the *Journal* in 1919 as a private enterprise, will continue as editor.

PROF. H. N. RUSSELL, of Princeton University, was presented with the Draper gold medal of the National Academy of Sciences of the United States of America at a dinner held in connexion with the New York meeting of the academy on November 15.

At the meeting of the Royal Geographical Society on December 11, at the Æolian Hall, the French Ambassador, on behalf of the Société de Géographie of Paris, presented a gold medal to Prof. J. W. Gregory for his geographical work in East Africa. Prof. Gregory afterwards read a paper, the substance of which will be found on p. 826, on the results of his recent journey in the mountains of Chinese Tibet.

THE Swiney lectures on geology, in connexion with the British Museum (Natural History), are being delivered at 5.30 P.M. on Tuesdays, Thursdays, and Fridays, at the Royal College of Science, South Kensington, by Prof. T. J. Jehu, who has chosen as his subject "Fossils and what they Teach." Admission to the lectures, twelve in number, is free.

A STATUE of Prof. Adolf von Baeyer, presented by the Interessengemeinschaft der Farbenfabriken, was unveiled in the Botanic Garden of the University of Munich on October 20. Prof. Willstätter spoke on behalf of the University, and Dr. Duisberg on behalf of the Interessengemeinschaft, Prof. Seeliger for the Bavarian Academy of Sciences, and Dr. Lepsius for the German Chemical Society.

A COMMITTEE "to inquire and to report as to the method of charging for gas on a thermal basis" has been appointed by the Board of Trade. The members of the committee are as follows: Sir Clarendon Golding Hyde (*Chairman*), Mr. Arthur Balfour, Sir James Martin, Mr. A. A. Pugh, and Mr. W. J. U. Woolcock. Mr. W. H. L. Patterson, of the Board of Trade, will act as secretary to the committee.

In a communication to the *Revue Scientifique* of October 28, Profs. Béhal, Haller, and Moureu urge the necessity of establishing some kind of protective measure to prevent German chemicals entering France. They point out that such measures have been established in the United States, England, Italy, and Japan, and they believe that prompt action of

a similar kind is necessary if French chemical factories are to remain in operation and French chemists in employment.

THE Bibliographic Institute for Auxiliary Scientific Work (1a Longridge Road, London, S.W. 5), established in 1917, affords assistance in the work of scientific research by supplying bibliographies upon subjects of any kind. The cost of such bibliographies depends entirely upon the range of work comprised in the special subject stated. Further information can be obtained from the English representative of the Institute at the above address.

A MEMORIAL window in Westminster Abbey in remembrance of Sir J. W. Wolfe Barry, past president of the Institution of Civil Engineers, was dedicated on December 7 by the Dean of Westminster. The window, which is in the nave, contains the figures of two angels holding tablets on which are inscribed the words "In Memory of John Wolfe Barry, K.C.B., F.R.S., Civil Engineer. Born 1836. Died 1918." Below the tablets are shields showing, among others, the arms of the Institution of Civil Engineers, of the University of London, and Sir John Wolfe Barry's personal arms.

THE annual meeting of the Mathematical Association will be held on Monday, January 1, and Tuesday, January 2, at the London Day Training College, Southampton Row. At the Monday meeting, which is to be at 5.30, Dr. S. Brodetsky will read a paper on "Gliding." On Tuesday there will be two sessions, one at 10 and the other at 2.30. At the first, a statement respecting the forthcoming report of the Sub-committee on the Teaching of Geometry

will be made by Prof. E. H. Neville, and the following communications will be read: "The Uses of Non-Euclidean Geometry to Teachers," W. C. Fletcher; "Simple Geometrical and Kinematical Illustrations of the Plane Complex," Prof. R. W. Genese; and "A Certain Dissection Problem," J. Brill. At the afternoon meeting Sir Thomas L. Heath will deliver his presidential address, taking as his subject "Greek Geometry, with Special Reference to Infinitesimals"; and Prof. A. Lodge will read a paper on "Differentials as the Basis for Teaching the Calculus."

A USEFUL Catalogue (New Series, No. 5) of second-hand books on sale by Messrs. Wheldon and Wesley, Ltd., 2 Arthur Street, W.C.2, has just been issued. It contains upwards of 1200 titles of works dealing with geology, mineralogy, mining, coal gas, water, building materials, metal manufactures, etc.

MESSRS. DULAU AND CO., LTD., 34 Margaret Street, W. 1, have just circulated a short, but choice, catalogue (No. 98) of Early Botanical Books. It is arranged under the headings "Herbals and Materia Medica," and "Early Agriculture and Gardening: Flora, Fungi, Orchids, Serial Publications, etc." Among the 356 works listed many are scarce.

THE Institute of Metals, 36 Victoria Street, London, S.W. 1, has issued a name and subject index of the Journal of Institute (vols. i.-xxv.). The volume contains more than 20,000 entries and covers metallurgical work done during the period 1909-21. Copies can be obtained through booksellers or direct from the Institute of Metals.

### Our Astronomical Column.

THE REPORTED NOVA IN LYRA.—In this column last week reference was made to the announcement of the appearance of a new star near the constellation of Lyra. The weather conditions for observing the object were not favourable, in this country at least, until the night of December 6, when observations were made at Greenwich, the Norman Lockyer Observatory in Devon, and at Armagh. All the observers reported that no bright star existed in the region of the supposed nova; in fact, photographs of the spectra of stars in that region down to the sixth magnitude, taken at the Norman Lockyer Observatory, did not reveal the presence of any star giving the characteristic spectrum of a new star. That a star of the first magnitude should dim so quickly in such a short period of time would be quite unique in the records of novae, so it must be assumed that the observer was mistaken or the announcement incorrect.

Dr. A. C. D. Crommelin writes: "Widespread cloud prevented the announcement of the discovery of a Nova in Lyra from being tested at once, and it was thought advisable to circulate it with a caution, so that advantage might be taken of any clear intervals to search for it. December 6 was fairly clear at Greenwich, and it was quickly found that there was no strange orb visible to the naked eye in the neighbourhood of the given spot. Telescopic comparison was made with the B.D. chart for an area of 4 square degrees round the position without

success. This search was conclusive, at least down to magnitude 7. Dr. Lockyer, Mr. Ellison (Armagh), Prof. Strömgen, and Dr. W. H. Steavenson also searched without success. The *Daily Mail* cabled to Bucharest and learnt that the Astronomical Society there knew nothing of the discovery. There is therefore practically no doubt that the announcement was the result of some mistake, the exact nature of which it is useless to conjecture."

LARGE FIREBALLS.—Mr. W. F. Denning writes:—"A large fireball appeared on November 24 at 6.40 P.M. which was seen from London, Manchester, and other places. It caused considerable flare in the sky for several seconds, and threw off a train of sparks at the later period of its flight. Comparing the various observations the radiant point is indicated at  $87^{\circ} + 34^{\circ}$  and the meteor fell from a height of 71 to 26 miles. Its length of path was about 124 miles, and velocity 25 miles per second. It passed over the earth from the region about 12 miles west of Grimsby to Shrewsbury. The radiant point near Theta Aurigae is a fairly well-known centre of a minor shower observed during the last half of November."

Another great fireball appeared at about midnight on December 6 and caused a surprising illumination in the region of north Lincolnshire. A noise like thunder was heard two minutes after the disappearance of the meteor. The flight of the meteor was from east to west, but details of an exact nature are lacking.

## Research Items.

**WATER-SUPPLY IN CENTRAL AUSTRALIA.**—Recent investigations in the heart of Australia have given it a more promising aspect than it had of old. In *Discovery* for December, Mr. O. H. T. Rishbeth, in discussing the economic possibilities of Central Australia, points out that a considerable area, about 150,000 sq. miles, has an average elevation of some 2000 ft. and rises to 5000 ft. in the Macdonnell and Musgrave ranges. But even in this more elevated part of the far interior the rainfall seems to be less than 10 in. a year and very uncertain in its occurrence. The future of Central Australia depends on the possibility of securing a satisfactory water-supply. A great deal could be done by the conservation of surface waters by means of dams, etc., but subterranean water must be the chief source. Many quite shallow wells seem to run freely with good water, but these can scarcely be looked on as inexhaustible. Artesian wells are promising and the water, though highly mineralised, is valuable for pastoral purposes. When the water-supply is assured and railway communications established, Mr. Rishbeth thinks this region has a future as a pastoral area. The carrying capacity and suitability of different parts for various animals must be tested; rabbits and dingoes must be systematically attacked, and stock routes with permanent wells opened up. Gold, mica, and wolfram are also known to occur, but difficulties of transport as well as lack of water have delayed mining.

**WATER IN THE KENT COALFIELD.**—The Kent coalfield was revealed by a borehole near Dover in 1800; since then no fewer than forty boreholes, comprising upwards of 90,000 feet of boring, have extended our knowledge of its area and depth. At present the Coal Measures have been penetrated by shafts at only four points; at no place have they been proved at a less depth than 800 feet below ordnance datum, yet the only important natural difficulty in their exploitation is the presence of large quantities of water in the overlying rocks. In a paper recently submitted to the Institution of Civil Engineers on "Underground Waters in the Kent Coalfield and their Incidence in Mining Development," Mr. E. O. Forster Brown has brought together many interesting facts concerning the quantity, quality, and local pressure of the water met with at different horizons, and has made suggestions, based on the results of his observations, which should prove of value in the development of mining and underground water supply in Kent. In descending order the water-bearing strata overlying the Coal Measures are, the Eocene, Chalk, Lower Greensand, Hastings beds, and estuarine sands of the Great or Inferior Oolite. During the last nine or ten years, 2 to 2½ million gallons of water per day have been pumped from Tilmanstone and Snowdown pits from the water-bearing beds below the Chalk. This water is allowed to run off at the surface. The author points out that the main faulting and fissuring follow the direction of the major tectonic folds, and that the water in the Oolite sands is divided into independent blocks by post-Jurassic faulting; he indicates the importance of a knowledge of this faulting in mining development. The water in the Oolite sands and in the Carboniferous Limestone below the Coal Measures probably comes from the French side of the Channel where these rocks are exposed in the Boulonnais.

**ANTS IN RELATION TO PLANTS.**—Myrmecophytism is dominated by the feeding habits of ants and their offspring. Until these are fully understood, it is scarcely possible to grasp the true ecological signifi-

cance, and the origin of the extreme cases of apparent or true symbiosis, between certain ants and certain species of plants. In a recent and very readable publication ("Ants in their Diverse Relations to the Plant World," Bull. Amer. Mus. Nat. Hist. xlv., 1922, pp. 333-583; extracted from "Ants of the American Congo Expedition," pt. 4), J. Bequaert has brought together the varied and disconnected links of existing knowledge, and a perusal of this work only emphasises how necessary the close co-operation of entomologists and botanists is for the proper interpretation of many of the problems. The dispersal of seeds by ants is evidently an important factor in plant distribution. In Europe a great many grasses and herbaceous plants rely almost exclusively, or at least to a large extent, on certain species of ants for the successful dissemination of their seed. The cultivation of fungi by ants is one of the curiosities of biology, but we know that when the female of *Atta sexdens* starts a new colony, she carries in her infrabuccal pouch a pellet containing fungal hyphae, with which to start fungus cultivation. She manures the mycelium until it attains a sufficiently luxurious growth to feed to the larvae. The fungal parasites of ants, and the intracellular bacteria of these insects, also come in for discussion. A large part of the paper is devoted to a review of the myrmecophytes of Africa, and there is also included a bibliography of more than 1100 references dealing with ants in relation to plants.

**RESEARCHES ON ORTHOPTERA AND DERMAPTERA.**—Part 3 of the "Faune de France" has recently come to hand and is devoted to a description of the Orthoptera and Dermaptera of that country. M. Chopard, the author of this fascicule, is a well-known authority on these insects. In a compass of a little more than 200 pages he has provided a useful and profusely illustrated systematic handbook on the rich fauna inhabiting France. Mr. Morgan Hebard (Occasional Papers of the Bernice Pauahi Bishop Museum, vol. vii., pp. 305-376, pls. xxvi.-xxvii.) revises the species of the same orders of insects inhabiting Hawaii. It appears that the Gryllidæ are the richest in species of any family and number 30 kinds, of which 24 are probably native and 6 "adventive." There are no Phasmidæ, no native species of Acrididæ, and of 16 species of Blattidæ only 2 are native. Of the Dermaptera there are 12 species, one half of which are native. In the Annals of the Transvaal Museum (vol. 9, 1922, pp. 1-99, 4 plates), Mr. J. A. G. Rehn describes the Dermaptera and Blattidæ of the Transvaal and Natal. In the first-mentioned group only 9 species are recorded and none are new; among the Blattidæ there are 73 species of which 24 are new. In the *Bulletin of Entomological Research*, vol. xiii., part 2, 1922, Mr. B. P. Uvarov contributes a study of the grasshoppers of the genus *Hieroglyphus* and their nearest allies. They are well known in India as pests of rice and sugar-cane, but hitherto only one species, *H. banian*, has been considered noxious. It appears, however, that several species are probably injurious, and this article is written with the view of aiding in their discrimination and recognition.

**SOME INDIAN LEECHES.**—In his notes on some leeches in the Indian Museum (Rec. Ind. Mus., xxii. pp. 689-727, December 1921) T. Kaburaki deals with twenty-seven species and makes three new genera. In the single example of Foraminobdella, a new genus of the Herpobdellidæ, found in a stream in the Nilgiri District, Madras, the digestive tract opens to the exterior not only at the mouth and anus but also

by a pore in the mid-dorsal line of the fourteenth somite. The gut of *Trematobdella*, as described by Blanchard, also opens by a pore in the mid-dorsal line, and in Horst's *Nephetis dubia* there are two slender passages from the gut to the ventral surface where they open to the exterior.

**PHILIPPINE CATTLE ROUND-WORM.**—B. Schwartz records (*Philippine Journ. Sci.* xx. No. 6, 1922) observations on the life-history of *Ascaris vitolorum*, a parasite of cattle and of water-buffaloes in the Philippine Islands. The eggs develop rapidly—but if exposed to the heat of the tropical sun are quickly destroyed—and contain larvæ after about twelve days. Such eggs hatch in the intestine and the larvæ migrate *via* the liver and lungs back to the alimentary canal, as in the common round-worm of man, *Ascaris lumbricoides*, but appear to have a greater tendency than in the latter species to linger in the liver.

**DISTRIBUTION OF OLIGOCHÆTA IN THE ANTARCTIC.**—Two further parts of vol. vi. of the Australian Antarctic Expedition are contributed by Prof. W. B. Benham—Part 4 on the Oligochæta of Macquarie Island and Part 5 on the Unarmed Gephyrea. In the former four oligochætes are recorded—two species of *Marionina*, one *Lumbricillus*, and one *Microsclolex* (*Notiodrilus*). In connexion with this last, Prof. Benham discusses the views that have been advanced to account for the present distribution of Oligochæta on the sub-Antarctic islands and concludes that this cannot be accounted for by polyphyly, floating rafts, carriage by birds, or by drifting seaweeds, and he is led back to the view, first put forward by Beddard in 1891, that the various islands and southern lands were once connected by land bridges. He believes that the former occurrence of chains of islands would suffice to explain the distribution of oligochætes, for the cocoons of these worms might then have been distributed on the feet of birds, and the pelagic larvæ of some of the littoral animals might have been able to survive for the short time necessary to pass across the intervening seas. He puts the origin of the Oligochæta "somewhere in the early Mesozoic epoch."

**FUNGAL DISEASES OF RICE.**—In the annual report of the Department of Agriculture of the Uganda Protectorate special attention is directed to local fungal diseases of rice. Early failures in the rice crop used to be attributed to unsuitable environmental conditions, but it is noteworthy that the symptoms of "blast" disease resemble the effect of drought and poor soil. This well-known disease, caused by *Piricularia oryzae*, is reported for the first time in Africa. The disease appears to be widespread, not one of the plots examined being completely free. Both leaves and stems are affected, and when the latter are attacked at both nodes and internodes the plants may break down and the whole plot collapse entirely in bad cases. The ears are sometimes normal, but if attacked the grains are empty or only half filled. At no time has any diseased condition of the roots been observed. "Blast" appears to be the only major disease of rice in Uganda, but in one instance *Gibberella saubinetii*, a fungus with a bad record, has occurred. The supposed conidial stage of this fungus, a species of *Fusarium*, has not been proved to be connected with the *Gibberella*, and it is not pathogenic to wheat, rice or maize, on all of which it was found in the country.

**PRAIRIE VEGETATION IN ILLINOIS.**—A paper by Homer C. Sampson under this title, published as Article 16, in vol. 13 of the Natural History Survey

of the State of Illinois, illustrates how American ecologists are attempting to record their main natural vegetation features before these are too much modified by man's activities. Sampson recognises the great importance of climate in determining the "centre of distribution" of the great prairie formation, which coincides roughly in its distribution with the area where the ratio of rainfall to evaporation lies between 60 and 80 per cent. As the prairie is met with farther from its natural centre of distribution, its stability becomes increasingly less so that it disappears before various edaphic and biotic influences. Sampson describes the origin of the prairie from the swamps and drier upland regions left at the close of the last glacial period. On these two soil types two different series of plant associations have followed, hydrophyte and xerophyte respectively in character, but both have ended in the prairie zone in the same association, dominated by *Andropogon furcatus*, the tall blue stem grass. Very striking must have been the appearance of the wide-rolling plains, clothed with this grass growing to a height of 10-12 feet, so that the earlier settlers could follow the movements of their cattle only by climbing to elevated ground and noting the agitation in the vast plains of grass. The author is to be congratulated on one unusual feature which terminates a memoir which is throughout admirably clear and concise. This is the bold attempt made to summarise the chief features of prairie vegetation in non-technical language so that the general public may learn the results of the study of one of the great natural assets of the state. This public should be interested in the author's statements as to the relative want of success that attends efforts to bring natural forest under cultivation as compared with the results of cultivation of prairie land which is normally richer in humus and less leached of its inorganic constituents.

**WEATHER IN THE WEST INDIES.**—Monthly and annual reports of the West Indies and Caribbean Weather Service have reached us for 1921 and a large part of 1922. The publication is carried out by Mr. Oliver L. Fassig, meteorologist in charge, at San Juan, Porto Rico, the service being in co-operation with the governments of the islands of the West Indies and of the adjacent coasts of Central and South America, under the controlling influence of the U.S. Weather Bureau. Daily rainfall returns are given from about 350 stations throughout the year 1921, and from more than 400 stations in the early months of 1922. In the latter year monthly mean and extreme temperatures are added. For each month the mean rainfall for the entire section is given based upon the reports from all stations observing, and usually a comparison is made with the normal. In 1921 the mean precipitation for the entire area was lightest during the month of April with a mean of 2.11 in. and a mean frequency of 8 days; the month of heaviest rainfall was October with 7.57 in. which fell on 16 days. The mean annual fall for the entire area was 54.32 in., and the mean number of days with rain was 144. In Jamaica the annual extremes at different stations ranged from 26 in. to 109 in., and in Trinidad from 60 in. to 156 in., the annual totals differing greatly, due to the varying topography. Observations are recorded of evaporation, water temperature, and earthquakes. The occurrence and movements of tropical storms are stated, warning of each storm being given by the U.S. Weather Bureau. Considerable development of the reports is evident, and the value of the data will in this way be further enhanced.

## Physiological Aspects of Physical Measurement.<sup>1</sup>

By Sir JOHN HERBERT PARSONS, C.B.E., F.R.S.

PHYSICISTS too often forget that the basis of physical measurements is biological, for the so-called "outer world" only exists for us by virtue of the sensations it arouses in our bodies. Physical measurements are open to the errors of all human observations, and these vary in degree according to the type of observation. In all cases the observation is the formation of a judgment, based on the sensations derived from the stimulation of a sensory organ. Physiological experiments show that stimulation of some sensory organs gives more sharply defined responses than others. Thus, the responses to smell and taste are crude and vague; those to moderate cutaneous stimuli—touch and temperature—much better defined; those to auditory stimuli, still better, and those to visual best of all.

But even among the varieties of a given type of sensation various degrees of definition are met. Thus pain, though cutaneous, is crude like smell and taste; in vision, form sense is much more accurately defined than colour sense. Definition, indeed, varies as the biological differentiation of the sense organ.

Now, the most highly differentiated sensory organ is the eye, and the fovea is its most highly differentiated part. Experiments show that the greatest discrimination is met with in foveal stimuli. The highest degree of sensory discrimination is the appreciation of continuity or lack of exact continuity in two straight lines set end to end, as in the vernier. This may be called *linear identity*, and it is noteworthy that it has been adopted empirically by physicists in the vernier, balance, and other instruments. Physicists have been very ingenious in applying this criterion to otherwise apparently unsuitable measurements, as, for example, the measurement of temperature. But there are many physical measurements to which it cannot be applied, or at any rate has not been applied. Photometry is an example. Here we are measuring the brightness of two lights. By various devices the principle of identity or equality of sensations is made use of—thus utilising the only accurate psychological comparison—but the quality of the sensation to be adjudicated upon does not admit of the accuracy of linear identity. Even in homochromatic photometry we are comparing the brightnesses of two illuminated areas. As is well known, these areas react upon each other physiologically—by the process of induction or simultaneous contrast. Moreover, the judgment is affected by the previous stimulation of the retinal areas concerned (successive contrast). It is further vitiated by variations in adaptation.

Still more open to error are the comparisons of brightness of different coloured lights, heterochromatic photometry. Here the difference in colour acts as a very disturbing element. Yet by practice it is possible to attain almost as accurate results as in homochromatic photometry. But how can we judge of the accuracy of these determinations? In this particular instance we can have recourse to the fact that the critical frequency of flicker depends upon brightness and follows a definite mathematical law. The eye is extremely sensitive to flicker, so that the disappearance of flicker affords a very sensitive criterion. It has been found that the results obtained by the flicker photometer confirm the results obtained by the best so-called "equality of brightness" observations.

No matter how delicate the criterion there are still errors of observation due to imperfections of a bio-

logical nature common to all human observers and also to the so-called "personal equation" of the given observer. How are these to be eliminated? Recourse is had to mathematical theory. The basis of the theory of error, which is a branch of the theory of probability, is that small errors will be more frequent than large ones; very large ones will be practically absent, and the mean is the result of the mutual destruction or compensation of many small sources of error acting in opposite directions.

The kinetic theory of gases is built entirely upon this statistical foundation, and its success in explaining the physical properties of gases is strong evidence in favour of the statistical theory. There are several mathematical "averages or means," and much depends upon the choice of the suitable "means," which itself depends upon the frequency distribution of the observations. Graphic methods of eliminating errors are constantly used by physicists. One of the commonest is the method of interpolation, and the smoothing of the curves.

An interesting example of the opposite aspect of averages is the modern view of atomic weights. These are some of the most accurate physical measurements ever made and have been corrected by the best statistical methods. Many of them approximate nearly to whole numbers and there are many theoretical reasons for believing that they are whole numbers. Recent investigations, chiefly by Aston, have shown that the atomic weights hitherto obtained are themselves averages: that there are many so-called "isotopes," having almost if not quite identical chemical properties, but differing from each other in the number of their electrons and also in their true atomic weights, which are invariably integers.

I hope that this philosophical parenthesis suffices to show that even in the matter of physical measurements the physiological aspects of the subject must perforce be taken into account. But in dealing with illumination we are dealing not only with foveal vision, but also with peripheral vision and alterations of sensitiveness of the eye under different conditions of stimulation. It is well known that the foveal region of all parts of the field of vision alters least in sensitiveness under different intensities of illumination. It is, therefore, relatively stable, and observations founded on criteria derived from central vision are proportionately trustworthy. It is quite otherwise with the other parts of the field of vision. Here the sensitiveness of the retina increases enormously with diminution of the intensity of stimulation. This function of retinal adaptation, which is of such tremendous practical importance in the life of the individual and indeed of the species, interferes very seriously with the accuracy of scientific investigations. Physicists have been led astray by ignoring it, as, for example, in the so-called "deviations from Newton's law of colour mixtures" described by König.

Physicists, indeed, are so accustomed to deal with measurements of the highest order of accuracy, founded upon what I have called "linear identity" observations, that they succumb to two errors: (1) that of regarding these observations as of the supreme validity of mathematical abstractions; (2) that of regarding other observations, to which the "linear identity" criterion is inapplicable, as of far greater accuracy than is in fact the case. When the mistakes arising from these errors are too patent to be ignored, physicists are apt to exhibit an unwarranted impatience with the shifting sands of

<sup>1</sup> From the presidential address to the Illuminating Engineering Society, delivered on May 25.



biological science. The fact must, however, be faced that in all cases the observing instrument is a living organ and is, therefore, in a perpetual state of change. The rate of change is relatively slight in the most favourable cases, but rapid and complex in the less favourable. Physicists have been notoriously successful in so reducing the physical complications of experiments to a minimum that the problem nearly approximates to a mathematical abstraction, and, therefore, the highest degree of accuracy. Further advance is to be sought by greater attention to the biological complexities in order that they, too, may be subject to more complete control.

A mass of evidence has of recent years accumulated

to show that in peripheral vision two mechanisms are simultaneously at work. Of these, one is chiefly concerned with vision under low intensities of light—what I have called scotopic vision. The end organ of this mechanism is the rods of the retinal neuro-epithelium. Photopic vision, or what may be called daylight vision, is chiefly carried out by the cones. The duplicity theory is so well established that it has even found its way into the writings of the physicists. The explanation and our knowledge of retinal adaptation depends upon these physiological facts. Since retinal adaptation plays a preponderant part in simultaneous and successive contrast its importance in photometry will be readily realised.

### The Design of Railway Bridges.

A SUBJECT of great importance to the general public is the safety of the thousands of bridges by means of which our railways cross roads, rivers, and other railways. Probably it occurs to few railway travellers to consider the complexity of the design of each bridge they cross and the organisation required to inspect, test, and maintain every bridge in a condition suited not only to the traffic for which it was originally designed, but also to the increased weights and speeds which have since been introduced. It is but natural that differences of opinion should arise between the railway companies which have to pay for their erection and maintenance, and the Board of Trade which has to satisfy itself that they are safe.

The Ministry of Transport has recently carried out a series of tests on actual bridges, and has issued a report containing suggestions which appear to foreshadow regulations requiring railway bridges to be heavier and therefore more expensive. This report has naturally aroused great interest and caused no small concern among the bridge engineers of the leading railway companies. At the meeting of the British Association at Hull, the Engineering Section devoted a morning to a discussion of the problem. Unfortunately no representative of the Ministry of Transport took part in the discussion, but the railway companies were well represented and the speakers included the bridge engineers of the Great Western, North Eastern, and Great Central companies. Taken together the papers constitute a concise but fairly complete review of the present situation.

Mr. J. S. Wilson, who opened the discussion with a general review of the questions involved, showed that the difference of opinion between the companies and the Board of Trade is nearly as old as the railways themselves. In 1839 Torksey Bridge across the Trent was tested by the representative of the railway commissioners preparatory to the opening of the Retford and Lincoln line. The deflection of  $1\frac{1}{2}$  inches with four locomotives and tenders on the centre of a span was considered excessive and permission to open the line was refused. The bridge had been designed by John Fowler who, with Sir Benjamin Baker, was responsible later for the Forth Bridge. He had followed the rules laid down by Fairbairn, and he suggested to the commissioners that some mistake had been made, but after further tests the latter persisted in their view that the stresses in the bridge were excessive. Finally, however, Fowler succeeded in convincing the commissioners that the girders, being continuous over the middle pier, were not stressed so highly as would otherwise be the case, and on his offering to reduce the weight of ballast on the bridge, the line was finally opened after a delay of three or four months.

The subsequent history of the bridge is of interest. The bridge is still there; for forty-six years it was unaltered and carried all traffic satisfactorily; in 1896 it was strengthened by the addition of a longitudinal girder. These old iron bridges designed by Fairbairn and Fowler, which have stood the test of seventy years' wear and tear and are still in good condition, are powerful arguments in favour of the view that bridges built on the same assumptions will be perfectly safe.

There are many difficulties, however, in the calculations and assumptions involved in the design, in allowing for the effect of impact due to the fact that the load is a live one, that is, not a stationary load, and in allowing for the effect of sleepers, rails, and ballast in strengthening the structure, distributing the load, and damping out the effects of impact. It is here that some doubt arises as to whether the intentions of the Ministry are correctly interpreted by the railway companies; it is useless to specify a factor of safety or a working stress unless one also specifies how the stress or factor is to be calculated or determined. The bridge designer may employ what appears to be a low factor of safety because he knows that the actual stresses are less than those calculated by the simple conventional methods usually adopted and that his actual factor of safety is consequently much greater. If a high factor of safety is specified, then it is open to the engineer to modify not his design but his methods of calculation so as to take account of the various strengthening factors usually neglected, and thus obtain a lower calculated stress and a higher factor of safety than would be given by the usual semi-empirical method.

One speaker in the discussion advocated making full-scale tests on old bridges which were being replaced; these could be re-erected and thoroughly tested, if necessary to destruction. All the speakers deprecated the premature promulgation of rules which would lead to heavier and therefore more expensive bridges, but urged that present practice should be followed until systematic research has been carried out and far more knowledge of the subject obtained than that on which the Ministry of Transport are proposing to act.

In their attitude towards riveted structures of iron and steel, engineers may be divided into pessimists and optimists, and Mr. Wilson's experience showed that the greatest optimists have been those most closely associated with the maintenance or actual construction, who would certainly be the first to detect any indication that the bridges were showing signs of weakness.

An engineering student is always taught that the stress produced by a live load is double that produced by the same load when steadily applied. This

assumes, however, that the live load is suddenly applied. If the time taken to apply the load is comparable with the period of vibration of the bridge, this is no longer true, and however fast a train is travelling the time taken to apply the load is considerable, and it is not surprising that actual measurements of deflection show that the stresses due to a moving train are in many cases but little greater than those due to the same load when at rest.

One speaker in the discussion at Hull emphasised the importance of minimising corrosion and looked forward to the possible use of stainless steel for bridges; in the meanwhile he had great hopes of the cement gun, by means of which a thin coating of cement is applied to the iron work.

A paper by Mr. J. S. Wilson and Prof. B. P. Haigh dealt very fully with the influence of rivet holes,

not only in bridges but in steel structures in general. This is of importance in the present controversy because of the uncertainty of the allowance to be made for the rivet holes in calculating the stress due to any given load. Calculation indicates that very high stresses should occur in the neighbourhood of rivet holes, but from a large number of experiments the authors came to the conclusion that "the metals used in practice have a ductility and other qualities which render them able to eliminate or accommodate these high stresses."

The various papers read and the remarks made by the speakers in the discussion all tended to show that the actual stresses occurring in bridge work are considerably lower than those usually calculated, and that past and present practice allows an ample factor of safety.

## The Alps of Chinese Tibet and their Geographical Relations.<sup>1</sup>

By Prof. J. W. GREGORY, F.R.S., and J. C. GREGORY.

SOUTH-EASTERN Asia is a region of interesting geographical enigmas which deal with the contrast between south-eastern and south-western Asia, the eastern prolongation of the Himalaya, the place of the mountains of south-western China in the mountain system of Asia, and the remarkable arrangement of the rivers of south-eastern Tibet, which has been described as one of the most extraordinary features of the earth's land surface. These problems are intimately connected with the formation of the basin of the Indian Ocean.

"Seek knowledge," said Mohammed, "even if it is found in China," and in accordance with that injunction of the Prophet the authors landed at Bhamo on the upper Irawadi, 50 miles from the Chinese frontier. This port of departure was selected in obedience to the principle of the Burmese proverb that an old road is a fast road; for the road from Bhamo to the Treaty Port of Tengyueh in south-western China is one of the trade routes of Asia which has been used since prehistoric times. At Tengyueh the Indians who had accompanied the expedition over the frontier mountains were sent back, a Chinese staff being engaged; permission was obtained to proceed to Likiang, the administrative headquarters near the borders of Chinese Tibet. As part of this road was across unsurveyed country in which brigandage was rife, the authorities insisted on the money of the expedition being sent on either by draft or along the main road.

The expedition arrived at Likiang before its money, and a further check was threatened by the refusal of the magistrate to allow the expedition to proceed further north. This decision was found to be in obedience to instructions from the provincial capital, but the magistrate of Likiang ultimately agreed to let the expedition proceed, provided he had no further instructions from the capital, on the receipt of a letter stating that the travellers were going on in spite of his warning and entirely at their own risk. Meanwhile a Chinese merchant in the city had agreed to advance half the amount of the draft, and as soon as this was paid the expedition hurried northward into Chinese Tibet to get beyond recall.

The path taken descended from the plateau into the valley of the Yangtze-kiang where, though 2400 miles from the sea, it is still a great river, and was then in high flood owing to the melting of the Tibetan snows. The structure of this valley and of its two parallel neighbours, the Mekong and Salween, was studied in a series of journeys along these rivers and

over the mountains between them. The inhabited districts along the Salween were smitten with famine owing to the failure of the previous harvest, and work there was impossible. The range of Kagurpu with its pyramidal snow-clad peaks and its great glaciers was inaccessible, as its crest is the forbidden frontier between Chinese and autonomous Tibet. Hence for a study of the mountain structure of this region the expedition turned eastward to the peaks and glaciers between the Mekong and the Yangtze-kiang, crossing passes from 16,000 to 18,000 ft. in height. Bad weather frustrated the attempt to explore the glaciers of Peima-shan and heavy floods hampered the return march to Likiang. Wide tracts of country around Tali-fu, the former Muslim capital which had withstood a siege of eighteen years during the Civil War of 1855-73, were flooded owing to the abnormally heavy rains. The caravan had to enter the city by climbing over the city wall, as the north gate was closed to keep out the mischievous spirits from the north which had brought the excessive rains that were threatening the country with famine. From Tali the expedition returned by the main road across Yunnan to the Irawadi in Burma.

The observations made during the journey show that the geography of Chinese Tibet is the result of mountain formation at two distinct periods. The deep valleys with their intermediate ranges, which are the most conspicuous topographic features, are the result of mountain movements of the age of the Coal Measures. These ancient movements gave the country a geographical grain trending north and south, and the Indo-Malayan mountains have been formed by the excavation of valleys along the weaker layers of the grain. Mountains belonging to a relatively modern date have been formed contemporarily with the upheaval of the Alps and Himalaya. The high peaks of Chinese Tibet rising over 24,000 ft. in height are due to these later uplifts. The main axis of the Himalaya passes through Chinese Tibet and is probably continued through the Nan-shan of southern China to the Pacific. The Burmese and Malay mountain arcs, which are the same age as the Himalaya, represent a loop to the south of the main mountain axis like the Persian loop in south-western Asia and the Apennine loop in Europe. The great rises on the floor of the Pacific, which reach the surface in the Hawaiian Islands and the coral islands of Polynesia, are probably the continuation of these two mountain lines, being like them due to the pressure interacting between the northern cap of the world and the tropical or sub-tropical zone.

<sup>1</sup> Substance of a paper read before the Royal Geographical Society on December 11.

The enigma of the three parallel rivers is explained as due to their valleys having been worn out along clefts through which the drainage from south-eastern Tibet was enabled to escape through the mountain rim of Chinese Tibet. This rim had been formed by the Himalayan movements which were due to the intense compression of the crust; on the relief from

that pressure the mountain ranges were broken by transverse clefts, and large blocks sank between a network of fractures. The basins formed by these subsidences gave the rivers great powers of enlarging their channels and thus of excavating the deep steep-sided valleys which are now the most conspicuous features in the topography of south-western China.

### The Present Position of the Whaling Industry.<sup>1</sup>

WHALING has been practised as an industry for some centuries. The pursuit of the Atlantic right whale was carried on in the Bay of Biscay at an early date, and was active at least so long ago as the twelfth century. The Greenland right whale was hunted in three areas, at successive periods, at first off Spitsbergen from about 1610, when few Atlantic right whales were left, then in Davis Straits from about 1719, and finally in the North Pacific and Bering Sea from about 1840. The sperm whale, which occurred in the whole of the tropical belt, though by no means restricted to this area, was hunted from about 1712.

The successful introduction of the modern harpoon-gun, with a harpoon carrying an explosive charge, dates from 1865, and has revolutionised whaling, by making it possible to capture the large and swift rorquals or fin whales. Modern whaling is concerned mainly with the humpback whale, the fin whale, and the blue whale, all of which are widely distributed in nearly all seas, although it is not certain whether each of these whalers' names indicates the same species in all parts of the world. After rorquals had been hunted in such localities as the Varanger

<sup>1</sup> Substance of a paper read before the Association of Economic Biologists by Sir Sidney F. Harmer, F.R.S., on November 10.

Fjord, Newfoundland, Iceland, the British and Norwegian coasts, and elsewhere, whaling on an unprecedented scale commenced off the edge of the Antarctic Continent in 1905, and is still being conducted energetically. The total catch in this area has exceeded 10,000 in a single year.

The principal whale-products of economic importance are: train-oil, sperm-oil, spermaceti, baleen, ambergris, whale meat, and the various forms of whale-meal or "guano." In a well-conducted factory all parts of the carcass are utilised.

With the exception of the Antarctic whaling, which has had a career of less than twenty years, whaling has been carried on consistently to an excessive amount, leading to the most serious reduction of the number of whales. The Atlantic and Greenland right whales were decimated almost to the point of extermination, the sperm whale industry has practically disappeared, and little remains now but the Antarctic whaling grounds. The efforts of all lovers of Nature should be directed to the restriction of whaling to an amount which is not inconsistent with the permanent preservation of these magnificent marine mammals and of the industry which they are so unfortunate as to support.

### Biometric Studies.

IN the current issue of *Biometrika* (vol. xiv. pts. i. and ii.) Dr. Kirstine Smith discusses the standard deviation of a coefficient of correlation computed from data derived from classes, members of which are mutually correlated, with special reference to the case of fraternal and parental correlations calculated from entries of siblings. She finds, *inter alia*, that the best determination of a fraternal correlation from a given number of observations is obtained by taking  $(1 + 1/r)$  offspring individuals from each family, where  $r$  is the fraternal correlation.

Mr. Egon S. Pearson contributes an important memoir on variations in personal equation. The experimental basis of the research was a series of five sets of measurements of different type; the form of sessional change, *i.e.* the resultant of factors operative within each series, is separated from the secular, or long period, change effective from one session to another; appropriate forms for the expression of each are discussed. It is evident that in the determination of the precise value of the correlation between successive judgments in a series, one has to reckon not only with physiological or psychological common factors, the organic basis of the correlation, but also with accidental errors which blur the record—the observational errors of some writers—and reduce the numerical value of the correlation. It is found that the correlations between successive judgments decrease approximately in geometrical progression with the number of intervals, a finding consistent with the assumption that there is little or no partial correlation between the observers' true estimates at intervals greater than one. The chief practical outcome of the work is to show that although "experience and accuracy may be gained by practice, it does not follow that the correlation between successive judgments will disappear."

The memoir is not only of practical interest to all experimenters, but also contains several contributions to statistical algebra. In connexion with the work on pp. 37 *et seq.*, a reference to the memoir of Anderson (*Biometrika*, x. 260) would have been in place, but no doubt Mr. Pearson will deal more fully with the literature of the subject in a sequel. He is to be congratulated on his first appearance in a field where one bearing his name must be judged by the highest possible standard.

Dr. Ernest Warren's paper concludes the account of work partly described in 1917 concerning inheritance in the foxglove. Dr. Warren holds that "the evidence of the present investigation is therefore definitely against any general application of the theory of pure lines and of genotypes of any appreciable magnitude, and further it indicates that selective breeding within self-fertilised generations of a homogeneous race is capable of modifying that race to a marked degree."

Prof. Karl Pearson and Mr. Egon Pearson show how to find a general polychoric coefficient of correlation, *i.e.* to fit the "best" normal surface to data subject to the limitation that the marginal totals are exactly reproduced. The arithmetical work is heavy, and the suggestion is that a determination of the correlation ratio from the array means—not a laborious task—will usually suffice.

Mr. James Henderson discusses the expansion of a function in tetrachoric functions, a matter of some importance to those who use the frequency systems favoured by Scandinavian mathematical statisticians.

It will be obvious that the fourteenth volume of *Biometrika* is as valuable to statisticians as its predecessors.

### University and Educational Intelligence.

**BELFAST.**—The trustees of the late Mr. Henry Musgrave have just paid to the Queen's University the sum of 57,000*l.* Of this sum the income of 7000*l.* is to be applied towards paying an additional Reader in connexion with the chair of physics. The income of 20,000*l.* is to be applied in founding and maintaining studentships of not less than 150*l.* per annum for the encouragement of research in pathology, physiology, biology and chemistry. The disposal of the remaining 30,000*l.* is left to the discretion of the Senate.

**CAMBRIDGE.**—The Very Reverend W. R. Inge, Dean of St. Paul's, and Sir Sidney F. Harmer, Director of the Natural History Departments of the British Museum, have been elected honorary fellows of King's College.

K. P. Chatterji, Fitzwilliam Hall, has been elected to the Anthony Wilkin Studentship in ethnology and archaeology.

The Raymond Horton-Smith prize has been awarded to Dr. A. B. Appleton, Downing College, for an essay on "Morphogenesis of Bone," and to Dr. H. W. K. Vines, Christ's College, for an essay on "Certain Physiological Functions of Calcium Salts."

The Gordon Wigan prize in chemistry has been awarded to R. G. W. Norrish, Emmanuel College, for an investigation on "The Photochemistry of Potassium Permanganate."

It is proposed to appoint a University lecturer in embryology.

**OXFORD.**—An important collection of early scientific instruments has been offered as a gift to the University by Mr. Lewis Evans, a condition attached to the gift being that a suitable place should be provided for showing it, this to be approved by Mr. Evans. The collection is at present exhibited in the Picture Gallery of the Bodleian Library, where it will be allowed to remain until the end of the summer of 1924. In the meantime it will be necessary to fix on a permanent lodging for the collection, and a proposal by Mr. R. T. Gunther, Fellow of Magdalen College, to allot for this purpose the upper-rooms of the historic Ashmolean Museum has the support of the heads of all the scientific departments concerned, of the Board of the Faculty of Natural Science, and of many other resident members of the University. As stated in NATURE of December 9, p. 783, the collection is especially rich in instruments for the determination of time. There is a series of astrolabes, sixty-three in number. There is also a large array of dials, both stationary and portable; the former includes Wolsley's sundial, which was probably designed by Nicolas Kratzer, the first Oxford professor of astronomy; while among the latter can be seen a fine Elizabethan finger ring dial, and a Roman portable dial of the second or third century A.D., stated to be the only perfect example known of this particular type of timepiece.

**DR. KATIE BARRATT**, lecturer in the department of biology at the Imperial College of Science, South Kensington, has been appointed principal of the Horticultural College, Swanley, Kent.

THE British Association Committee on Training in Citizenship has produced three valuable reports, each of which is available separately for a few pence, and at reduced prices if purchased in dozens or hundreds. The first report, presented at the Cardiff meeting in 1920, contains a syllabus of a course in civics and notes on regional surveys; the second, presented at Edinburgh in 1921, surveys the position of the subject and summarises views of leading teachers upon its scope and purpose; and the third, presented at the Hull meeting in September last, contains a full biblio-

graphy of civics. Prices and other particulars may be obtained from the honorary secretary of the committee, Lady Shaw, 10 Moreton Gardens, London, S.W.5.

WE have received from the University of Hong-Kong a pamphlet describing its aims and needs, with special reference to an offer by the Rockefeller Foundation of New York of an endowment of half a million dollars for chairs of medicine and surgery, conditional only upon the Faculty being brought into harmony in other respects with modern standards of efficiency. This will cost at least 400,000 dollars. The university holds a position unique among British universities in that its policies are to a large extent dominated by its nearness to and relations with a foreign country. Its charter of incorporation declares that its objects include "... the development and formation of the character of students of all races, nationalities, and creeds, and the maintenance of good understanding with the neighbouring country of China," and its general aim has been defined as "the provision of facilities and especially of the atmosphere of a residential British university with such modifications ... as the national and intellectual outlook of the Chinese student may call for." One of its chief merits in the eyes of Chinese parents is that its students get the benefit of a British university education without becoming denationalised. It was opened only two years before the outbreak of the Great War and until 1920-21 its progress was slow. During the past two years, however, the number of students has rapidly increased, and there are now about 250, nearly all of whom reside in university or recognised (mission) hostels. Of students who have graduated from the several faculties (medicine, engineering, and arts) the greatest number—77—took degrees in engineering.

**PROF. L. NATANSON** sends us the following information summarising the growth and progress of university education in Poland. In the last completed year (1921-22) Poland had five State-endowed universities (Cracow, Warsaw, Lwów, Poznan, Wilno), two high technical schools (Warsaw, Lwów), two "free" or private universities (Lublin, Warsaw), and seven other special colleges of university rank. In these institutions, 1926 persons were engaged in teaching during the session under review, namely: 833 full or "ordinary" professors, 176 assistant or "extraordinary" professors, and 917 lecturers and provisionally appointed teachers. The total number of students enrolled for the same period was 34,708, of whom 8015 were women. The University of Warsaw had the largest number of students in attendance, namely, 7518; the Technical High School of Warsaw had 4112 students. Polish universities contain faculties of theology, jurisprudence, medicine, physical and natural science, philosophy, history and philology; in addition to these, sub-faculties or special departments exist in several universities, devoted to agriculture, pharmacy, veterinary science, and so on. As to the speciality of their study, the students may be divided as follows: theology 1 per cent., jurisprudence 29.1, medical science 13.2, pharmacy 0.9, veterinary science 1.1, stomatology 1.5, philosophy, philology, history and pedagogical science 26.4, agriculture 5.9, commercial science 2.1, chemistry 2.8, mining 0.8, other technical studies 14.4 per cent. The following information is also available relating to the mother-tongue of students in the University of Warsaw: Polish language 89.0 per cent., Russian 2.0, German 0.25, Hebrew 4.25, Jewish 3.25, other languages 1.25 per cent. About 74 per cent. of the number of students were trained in secondary schools chiefly of classical and literary type; the rest, about 26 per cent., had received preparation in schools in which experimental and practical science was the basis of instruction.

## Calendar of Industrial Pioneers.

**December 18, 1888.** Joseph James Coleman died.—One of the pioneers of the cold storage industry, Coleman was first a teacher of chemistry and then chemical engineer to Young's Paraffin Works, Bathgate, Glasgow, where he devised means of liquifying gases, and with Bell introduced the Bell-Coleman dry-air refrigerating system which revolutionised the meat-carrying trade.

**December 19, 1877.** Heinrich Daniel Ruhmkorff died.—Ruhmkorff was born in Hanover in 1803 and in 1819 went to Paris as assistant in a laboratory. There he started in business for himself and became a successful electrical instrument maker. In 1844 he invented a thermo-electric battery, and in 1851 brought out the Ruhmkorff coil for which he afterwards received a prize of 50,000 francs at the French Exhibition of Electrical Apparatus.

**December 20, 1904.** Sir Isaac Lowthian Bell died.—The son of an engineer of Newcastle, Bell studied at Edinburgh and at the Sorbonne, and in 1854, with his brothers, founded the Clarence Iron Works on the Tees, the firm ultimately employing some 6000 men. Bell was distinguished as an investigator and writer on metallurgy, and as a man of affairs assisted to found the Iron and Steel Institute, of which he served as president in 1873-75. He was also the first recipient of the Bessemer Gold Medal.

**December 21, 1909.** Charles B. Dudley died.—From 1875 to 1909 Dudley was chemist to the Pennsylvania Railroad Company, in which situation he carried out a number of important researches on the properties of materials and other matters connected with railways. He was president of the American Chemical Society, and at the time of his death, president of the International Association for Testing Materials.

**December 22, 1867.** Jean Victor Poncelet died.—A distinguished French engineer and mathematician, Poncelet passed through the École Polytechnique, served in the army, was taken prisoner on the retreat from Moscow, and during his confinement began writing his "Traité des propriétés projectives des figures." He rose to high military rank, held a chair of mechanical physics in Paris, published a treatise on practical mechanics, improved the water wheel, and invented a turbine.

**December 23, 1895.** Sir Edward James Harland died.—The founder of the great shipbuilding firm of Harland and Wolff, of Belfast, Harland was born in 1831 at Scarborough, served an apprenticeship under Robert Stephenson at Newcastle, and became draughtsman to J. and J. Thomson, Glasgow. In 1854 he removed to Ireland, becoming the owner of a small shipbuilding concern, in which he was joined by Wolff in 1860. Among the most notable vessels he constructed was the Atlantic liner *Teutonic*, which, built in 1889, was the first mercantile vessel to be fully armed and equipped as an auxiliary cruiser. She was 560 feet long, displaced 16,740 tons, and with 17,500 horsepower attained a speed of twenty knots.

**December 23, 1865.** Alan Stevenson died.—The eldest son of Robert Stevenson (1772-1850), whom he succeeded as engineer to the Scottish Lighthouse Commissioners, Stevenson erected ten lighthouses, among them being that at Skerryvore, "the finest example for mass combined with elegance of outline of any extant rock tower." This lighthouse, which was built between 1838 and 1843, is 138 feet high and weighs 4300 tons. E. C. S.

## Societies and Academies.

LONDON.

**Royal Microscopical Society, November 15.**—Prof. F. J. Cheshire, president, in the chair.—C. Singer: The earliest drawings made by means of the microscope. These drawings, probably the earliest made, were prepared in 1625, 3 years before the birth of Malpighi and 8 years before the birth of Leeuwenhoek. They represent the anatomy of a bee, of which the mouth parts are particularly accurately rendered. The drawings are to be found on the fly-leaf of an excessively rare book, the "Melissographia" of Federigo Cesi, Duke of Aquasparta. The only specimen of this book known to exist is in the Lanuvian library at Rome. The drawings were made under the supervision of Cesi himself and of his colleague in the first "Academy of the Lynx," Francesco Stelluti. A mechanical microtome was constructed by the instrument maker Cummings in 1770 and described by the notorious Sir John Hill.

**Physical Society, November 24.**—Dr. Alexander Russell, president, in the chair.—E. G. Richardson: The theory of the action of the singing flame fits the results most closely, in that (1) heat is given by the flame to the air in the tube at each condensation, and (2) stationary waves are formed in the gas as well as in the air-tube. But the lengths of gas-tube unfavourable to the "singing" cover a more restricted range than Lord Rayleigh surmised.—Miss Alice Everett: Unit surfaces of Cooke and Tessar photographic lenses. A number of rays in an axial plane (and a few general rays) are traced through the lens systems by exact methods, and on each ray the positions of the conjugate points for unit magnification are found by Mr. T. Smith's formulae. For general rays the loci of these "unit points" are three-dimensional. They are surfaces only when the chief rays are bound by some condition such as passing through a fixed point of the object. Within the region for which the lenses are designed, the curvature of both object and image unit-point loci is positive (convex to the light source) and the image locus is more curved than the object locus.—R. Ll. Jones: Vibration galvanometers with asymmetric moving systems. The theory of vibrations of a system with two degrees of freedom is given, expressions for the amplitudes of the forced vibrations are deduced, and the conditions for resonance ascertained. The results are applied to a galvanometer in which the moving system is asymmetrically hung on a laterally yielding axis, and it is found that the formula for the amplitude is capable of reproducing with fair accuracy the sensitivity curve of the galvanometer, which shows multiple resonance. Asymmetry always lowers the sensitivity of the resonance.—Paul Schilowsky: Some applications of the gyroscope. To stabilise a system in unstable equilibrium a reaction must be set up between the system and the gyrost at of such a character as to help the precession of the gyrost at during the return of the system to normal. To check the oscillations of a stable system, the reaction must be such as to oppose such precession. The gyrost at must be power-driven to neutralise friction. A collection of apparatus for teaching purposes, comprising, *inter alia*, models illustrating the precession of the earth, a method of optically projecting an image of a spinning top, and small mono-rail models, was exhibited. To prevent rocking in a model ship a

gyrostatic fly-wheel is mounted with its axle vertical in a frame, which can both rock about and slide along an axis transverse to the ship. In an aeroplane the problem of combining automatic stability with mobility while avoiding dangerous stresses was discussed. Angular velocity of the aeroplane about a vertical axis causes a tendency to precess in a gyroscope rotating about an horizontal axis. This is balanced by a gravity control, and the angle moved through in attaining a balance affords a measure of the required angular velocity. In models of mono-rail gyrostatic apparatus the fly-wheel is mounted with its axle vertical in a frame which can tilt in a fore-and-aft plane and also slide sideways under gravity. The frame is mounted by a pinion co-axial with and geared down from the fly-wheel; the pinion lies between, but normally clear of, two parallel fixed racks mounted on the carriage, and having their lengths in a fore-and-aft direction. In practice the gyrostatic apparatus would form from 3 per cent. to 5 per cent. of the load of a ship, and from 5 per cent. to 10 per cent. of the load of a mono-rail carriage.—P. Ditisheim: A new balance for compensating the temperature error of watches and chronometers. Elinvar, an alloy invented by Dr. Ch. Ed. Guillaume, the elasticity of which is not affected by changes of temperature, is used for the hair-spring. Satisfactory timing can thus be obtained up to certain limits with a plain solid uncut balance. To apply the elinvar spring to higher-grade watches a new compensation balance has been designed. It is made from a plain monometallic uncut ring into which two very small symmetrical bimetallic blades are inserted. The latter will enable small corrections to be made in order to obtain very fine rates.

**Aristotelian Society**, November 27.—Prof. A. N. Whitehead, president, in the chair.—R. F. A. Hoernlé: Notes on the treatment of "Existence" in recent philosophical literature. The ontological argument is treated in current philosophical literature (*a*) in a restricted form, in which it applies only to the unique case of God, and (*b*) in a generalised form, in which it is one with the problem of the validity (or "reference to reality") of thought in general. Prof. A. E. Taylor's criticisms of the restricted argument, in his article on "Theism" in the "Encyclopedia of Religion and Ethics," are mutually contradictory, but they contain the valuable suggestion that the validity of the argument depends on the meaning of the term "God," or of the terms defining "God." What these terms mean can be decided only by asking what they express, and this requires that we should not divorce the language of the argument from the religious experience (= Anselm's *fides*) which underlies it. Thus, the restricted argument appears as but a special case of the generalised argument which depends on the principle that experience, as the union of "that" and "what," "existence" and "essence," supplies the missing existential premise for all meanings which are well-founded. The generalised argument depends on maintaining consistently the "epistemic" against the "formal-logic" point of view. In formal logic, no definition, as such, can imply the existence of the thing defined; no class-concept can imply that the class has members. But, if instead of beginning with definitions, concepts, suppositions (*Annahmen*), we take the epistemic point of view and ask what the terms of the definition, etc., mean, i.e. what they express, or what we are asked to think *with*, we are driven back to concrete experience in which meanings are realised, and in which, therefore, essence is not divorced from, but is one with, existence.

**Linnean Society**, November 30.—Dr. A. Smith Woodward, president, in the chair.—R. J. Tillyard: The wing-venation of the order Plectoptera or Mayflies.—D. S. M. Watson and E. L. Gill: The structure of certain palaeozoic Dipnoi (fishes).—J. Duncan Peirce: The Giant Trees of Victoria. The tallest trees grow in gullies between ridges, the greater moisture and abundance of leaf-mould conducing to their height; the highest tree measured was 326 ft. in.

## CAMBRIDGE.

**Philosophical Society**, November 13.—Mr. C. T. Heycock, president, in the chair.—A. Smith Woodward: The skulls of palaeolithic men.—W. M. H. Greaves: On a system of differential equations which appear in the theory of Saturn's rings.—C. G. Darwin and R. H. Fowler: Fluctuations in an assembly in statistical equilibrium.

## SHEFFIELD.

**Society of Glass Technology**, November 22.—W. E. S. Turner: The glass industry and methods of manufacture in Czecho-Slovakia. The technical side of the glass industry has not in recent years made anything like the progress that it has in this country. The Bohemian glass industry is living largely on its old tradition and the existing store of knowledge. Machinery scarcely exists for the manufacture of glassware. A great deal of money was made in the industry in the boom years of 1919 and 1920, but very little was put into the industry to improve it. In many methods, from a technical point of view, Great Britain leads the Continent at the present time.—A. Cousen: Selenium in the production of colourless glass. A large number of experimental melts were made to determine the effect of various batch materials on the decolourising power of selenium and the effect of the duration of melting on the colour developed.

## DUBLIN.

**Royal Dublin Society**, November 28.—Mr. G. Fletcher in the chair.—J. Wilson: On the variation of milk-yield with the cow's age and the length of the lactation period. Ten years ago, working on data, from the cows exhibited at the London Dairy Shows, it was found that, if cows' yields at eight years old be set down as 100, the yields at earlier ages work out at about 67 for 3-year-olds; 81 for 4-year-olds; 90 for 5-year-olds; 95 for 6-year-olds; and 98 for 7-year-olds. Recently Dr. Raymond Pearl of Washington and Dr. Tocher of Aberdeen, working with data collected by the Ayrshire Cattle Milk Records Committee, have found yields for the younger ages to be considerably higher, but the Ayrshire records cannot be used to find how yield increases with age, because the breed has been out of equilibrium since about twenty years ago; the records are loaded in favour of those of the younger ages. If twelve months from calf to calf be taken as the normal lactation period, the annual yield is reduced by about 20 gallons in an eleven months lactation, and increased by about 35, 65, and 90 gallons in thirteen, fourteen, and fifteen months lactation periods.—H. H. Poole: On the detonating action of  $\alpha$ -particles. Experiments show that the probability of detonation of a specimen of iodide of nitrogen by  $\alpha$ -particles is proportional to the concentration of the particles, and not to the square, or a higher power, of the concentration. Hence, detonation is caused by a single  $\alpha$ -particle, and not by the joint effect of two or more particles, and it is reasonable to assume that detonation is caused by the collision of the particle with a nitrogen or a hydrogen nucleus. Fulminate of mercury, silver

azide, and several other explosives were not detonated by exposures to  $\alpha$ -particles which would have caused several thousand detonations of iodide of nitrogen. Probably only a very sensitive body, such as the iodide, can be detonated in this way, and the risk of such an effect with detonators or explosives in common use is negligible.—T. G. Mason: Note on the growth and the transport of organic substances in bitter cassava (*Manihot utilisima*). Weekly measurements of 20 plants were made over a period of 27 weeks; alternate plants were ringed close to the ground. The rate of growth of the stems of the ringed plants was not affected by the operation for about 3 weeks; it then commenced to lag behind that of the unringed plants. The weight of the tuberous roots formed by the ringed plants was about one quarter of that formed by the unringed; the weight of the stem was more than 1.2 times as much. Probably the activity of the cells of the apical meristem is not controlled by the available supply of organic substances, but is determined by autogenous changes within the growing point. No evidence was obtained of the presence of a factor correlating the activity of the apical meristem and the growth of the tuberous roots. The results are in accord with the view that the rate of growth of the stem is conditioned by the catalytic activity of the cells of the apical meristem.

## PARIS.

Academy of Sciences, November 20.—M. Emile Bertin in the chair.—The president announced the death of M. G. Lemoine.—Marcel Brillouin: Einstein and Newtonian gravitation. Remarks on a recent note by M. Le Roux. The criticisms of M. Le Roux are regarded as unfounded.—Pierre Termier: The structure of the eastern Alps.—L. Joubin: The geographical distribution of some deep-sea corals in western European seas. In consequence of the increase in the size and power of steam trawlers, trawling is now carried out at much greater depths than formerly. As a result, the quantities of coral brought up in the nets causes great inconvenience. As a guide to fishermen, a chart is given showing the distribution of the most objectionable corals (*Lophelia*, *Amphihelia*, *Dendrophyllia*), so that the trawlers can avoid these localities.—E. Mathias, C. A. Crommelin, and H. Kamerlingh Onnes: The rectilinear diameter of neon. The purification of the neon used in these experiments is described in detail, and its purity was confirmed of observations of the critical phenomena. Neon obeys the law of the rectilinear diameter. Like other gases, the diameter shows a deviation in the neighbourhood of the critical point. In the case of hydrogen the deviations are distributed irregularly, but with neon they are systematic: at low temperatures the diameter is slightly convex to the temperature axis, and at higher temperatures slightly concave. Argon, nitrogen, and carbon dioxide behave similarly.—M. Charles Camichel was elected Correspondant for the section of mechanics.—S. Bays: Steiner's cyclic systems of triplets.—A. Myller: Remarkable ruled surfaces passing through a given curve.—Paul Mentré: Complexes which present projective singularities of the second infinitesimal order.—H. Roussilhe: Results obtained in 1921 and 1922 by the application of aerial photography to precision plans on the large scale. The mean errors of plans derived from aerial photographs are less than those of a topographical plan taken with every precaution; the area covered by a given staff is also greater when the photographic method is employed.—C. Raveau: Fresnel's law of the entanglement of the æther.—Emmanuel Dubois: The minimum potential of electric discharge in gases

at low pressures. Some anomalies described in an earlier communication have been now shown to be due to the presence of saline substances on the electrodes.—L. Bouchet: An absolute plane-cylinder electrometer. A cylinder is mounted on a balance beam and the attraction between the cylinder and a plane surface measured. The theory of the instrument is developed. The limits between which the formula holds have been determined by experiment.—Georges Déjardin: The production of the spectrum of mercury. The influence of helium. A study of the spectrum emitted by mercury vapour traversed by electrons of variable velocity. The lines are those of the arc spectrum. For potentials below 20.4 volts a mixture of helium and mercury vapour gives the same arc spectrum as that observed in the absence of helium. Above 20.4 volts the mercury spectrum undergoes modification, and at the same time the helium spectrum appears.—Pierre Lafon: Anomalies in the expansion of glass.—A. Portevin: The reduction and disappearance of internal strains in steels by reheating followed by slow cooling.—André Kling and D. Florentin: The spontaneous formation of sulphate on limestone in urban centres. Chemical analyses of various limestone structures, showing the serious attack by the sulphuric acid in town atmospheres.—MM. Tiffeneau and Orékhoff: The semipinacolic transposition of the alkyldrobenzoins: the influence of the alkylradicles.—Raymond Delaby: The alkyglycerols. The preparation of vinylalkylcarbinols.—E. Grandmougin: The acyl-aminoanthraquinones as vat dyes.—Paul Gaubert: The action of heat on spherulites.—H. Joly: Preliminary note on the general direction and age of the folds of the Celtiberic Chain (Spain).—M. Teilhard: A fauna of mammals found in northern China.—V. Van Straelen: The decapod crustaceans of the Callovian of Voulté-sur-Rhône (Ardèche).—Lucien Daniel: Hyperbioses of the sunflower and artichoke.—Maurice Lenoir: The nucleoles during the prophase of kinesis II. of the embryonic sac of *Fritillaria imperialis*.—M. Mascré: The stamen of the Boraginaceæ.—Mlle. Marie Braecke: The presence of aucubine and of melampyrite (dulcite) in several species of *Melampyrum*. Aucubine was isolated from *Melampyrum pratense*, *M. nemorosum*, and *M. cristatum*: dulcite (*Hünefeld's melampyrite*) was also extracted in the pure state from the two latter species.—Pierre Lesage: The comparative action of sylvinite and its components on the first development of plants. Sylvinite proved more favourable to the development of seedlings than its constituents (chlorides of sodium, potassium, magnesium, and calcium sulphate) taken separately, or even when mixed in the proportions present in the mineral employed.—J. Stoklasa: The respiration of the roots. Experiments are described confirming the conclusion published by the author in an earlier communication, that no acid, organic or inorganic, other than carbonic acid is secreted by growing roots. The respiration of the roots is more intense in the presence of air containing radium emanation.—A. Goris and P. Costy: Urease and urea in fungi.—L. Léger and A. Ch. Hollande: Coccidia of the intestine of the eel.—L. M. Betances: Some refinements on the morphogenesis of the hæmatic cell.

## CAPE TOWN.

Royal Society of South Africa, September 27.—Dr. J. D. F. Gilchrist, president, in the chair.—H. B. Fantham: Some Protozoa found in soils in South Africa. Protozoa belonging to the Sarcodina, Mastigophora, and Ciliata have been found. As regards actual numbers of organisms, flagellates are the

most numerous. There is daily variation in the numbers of a Protozoan in a given quantity of culture. Dark, heavy soils containing much humus yielded more kinds of Protozoa than sandy ones. Samples of soil taken relatively near the surface, say six or eight inches down, usually yielded more Protozoa than deeper samples. Cultivated soils yielded more species of Protozoa, especially of Ciliata, than uncultivated ones. Owing to partial sterilisation of South African soils by solar heat and drought, the number of Protozoa in a given area of soil seems to be less than in soils from England or the northern United States. The ingestion of bacteria by soil Protozoa has, so far, not been often observed naturally in South African soils.—**J. A. Gilmore**: Note on elasticity of Dwyka Tillite. Investigation of Dwyka Tillite from Matjesfontein, Cape Province, shows that for an absorption of water of less than 1/400 gm. per gm., Young's Modulus decreases by about 12 per cent., whereas for an absorption of order 1/800 gm. per gm. the crushing strength increases by about 50 per cent. or more.—**H. O. Mönnig**: On some new South African parasitic nematodes.—**Sir Thomas Muir**: Note on the co-venience of the primary minors of an axisymmetric determinant.—**T. J. Mackie**: The serum constituents responsible for the Sachs-Georgi and the Wassermann reactions. Sera were fractioned by Liefman's carbon-dioxide method; the carbonic-acid-insoluble globulin was inactive and inhibitory in the flocculation test. The carbonic-acid-soluble fraction was further fractioned into pseudo-globulin and albumin components and flocculation was found to be due almost entirely to the former. In the Wassermann reaction, the most active fraction is the carbonic-acid-insoluble globulin.—**J. R. Sutton**: Note on the propagation of heat in water. Harmonic analysis of hourly observations of the temperature of water in a brick cistern, 7 feet square and 30 in. deep, shows that the whole body of water is heated nearly simultaneously (chiefly by the sun's rays) and that the surface temperature is propagated downward as a wave of about 7 in. per hour.

**Royal Society of South Africa**, October 18.—**Dr. J. D. F. Gilchrist**, president, in the chair.—**Miss A. V. Duthe**: The cones, spores, and gametophytes of *Selaginella pumila*.—**F. G. Cawston**: South African larval trematodes and the intermediary hosts. The commoner species of fresh-water mollusc found in certain rivers of South Africa, as well as some lagoon inhabitants which are occasionally found in quite fresh water, together with the commoner larval trematodes of these localities, are described.—**J. Moir**: Colour and chemical constitution, Pt. XVIII.: Colourless substances in concentrated sulphuric acid solution (halochromy). Observations on coloured solutions in sulphuric acid of 25 simple substances, mostly colourless *per se*, are recorded, and a scheme for calculating colour from chemical constitution is put forward.—**J. Stuart Thomson**: African Alcyonaria with a statement of some of the problems of their dispersal.

### Official Publications Received.

Straits Settlements. Annual Report on the Raffles Museum and Library for the Year 1921. By Major J. C. Moulton. Pp. 16. (Singapore.)

The Royal Technical College, Glasgow. Annual Report on the One Hundred and Twenty-sixth Session adopted at the Annual Meeting of Governors, held on the 17th October 1922. Pp. 71. (Glasgow.)

County Borough of Warrington: Museum Committee. Report of the Keeper of the Museum for the Two Years ending 30th June 1922, with a List of the Principal Additions to the Museum Collections. Pp. 18. (Warrington.)

Department of the Interior: Bureau of Education. Bulletin, 1922, No. 29: State Laws relating to Education enacted in 1920 and 1921. Compiled by Wm. R. Hood. Pp. iv+269. (Washington: Government Printing Office.) 25 cents.

Department of Fisheries, Bengal. Bulletin No. 19: Statistics of Fish imported into Calcutta for the Year ending 31st March 1922. Pp. 14. (Calcutta: Bengal Secretariat Book Depot.) 8 annas.

## Diary of Societies.

### SATURDAY, DECEMBER 16.

**BRITISH ECOLOGICAL SOCIETY** (Annual Meeting) (at University College), at 10.30 A.M.—**Dr. R. Lloyd Praeger**: Dispersal and Distribution (Presidential Address).—**Dr. Cockayne's** Work on the Tussock Grassland of New Zealand (Lantern and Specimens).—**J. Ramsbottom**: The Mycology of the Soil.—**W. H. Pearsall**: Plant Distribution and Basic Rations.

**BRITISH PSYCHOLOGICAL SOCIETY** (Annual General Meeting) (at University College), at 3.—**S. J. F. Philpott**: The Analysis of the Work Curve.—**H. Gordon**: Hand and Ear Tests.

### MONDAY, DECEMBER 18.

**ROYAL GEOGRAPHICAL SOCIETY** (at Lowther Lodge, Kensington Gore), at 5.—**Col. Sir Gerald Lenox-Conyngham**: The Proposed Determination of Primary Longitudes by International Co-operation.

**INSTITUTION OF ELECTRICAL ENGINEERS** (Informal Meeting), at 7.—**E. E. Sharp** and others: Discussion of Time Switches.

**INSTITUTION OF MECHANICAL ENGINEERS** (Graduates' Section), at 7.—**A. J. Gould**: Warships.

**ROYAL INSTITUTE OF BRITISH ARCHITECTS**, at 8.—**A. N. C. Shelley**: The Law of Building outside London.

**ARISTOTELIAN SOCIETY** (at University of London Club, 21 Gower Street), at 8.—**Prof. R. W. Sellars**: Body and Mind.

**CHEMICAL INDUSTRY CLUB** (at 2 Whitehall Court), at 8.—**Dr. W. R. Ormandy**: Paper.

### TUESDAY, DECEMBER 19.

**ROYAL SOCIETY OF MEDICINE**, at 5.—General Meeting.

**ROYAL STATISTICAL SOCIETY**, at 5.15.—**T. T. S. de Jastrzebski**: Changes in the Birth Rate and in Legitimate Fertility in London Boroughs, 1911-1921.

**INSTITUTION OF CIVIL ENGINEERS**, at 6.—**F. M. G. Du-Plat-Taylor**: Extensions at Tilbury Docks, 1912-1917.

**INSTITUTE OF MARINE ENGINEERS, INC.**, at 6.30.—Film illustrating Industrial Works—Messrs. Hadfield's.

**ROYAL PHOTOGRAPHIC SOCIETY OF GREAT BRITAIN** (Technical Meeting), at 7.—**H. T. G. Meredith**: Gravure.

**ROYAL ANTHROPOLOGICAL INSTITUTE**, at 8.15.—**Dr. C. Fox**: The Distribution of Population in the Cambridge Region in Early Times, with special reference to the Bronze Age.

### WEDNESDAY, DECEMBER 20.

**ROYAL SOCIETY OF MEDICINE** (History of Medicine Section), at 5.—**Dr. Nixon**: The Debt of Medicine to the Fine Arts.

**ROYAL METEOROLOGICAL SOCIETY**, at 5.—**C. J. P. Cave** and **R. A. Watson Watt**: The Study of Radiotelegraphic Atmospherics in Relation to Meteorology.—**C. J. P. Cave**: Winter Thunderstorms in the British Islands.—**D. E. Row**: Forecasting Sky Types.

**GEOLOGICAL SOCIETY OF LONDON**, at 5.30.—**W. A. Richardson**: A Micrometric Study of the St. Austell Granite (Cornwall).—**W. G. Shannon**: The Petrography and Correlation of the Igneous Rocks of the Torquay Promontory.—**Prof. O. T. Jones**: Demonstration of the Crystallisation of a Doubly-Refracting Liquid.

**ROYAL MICROSCOPICAL SOCIETY**, at 8.—**J. E. Barnard**: Sub-Bacteria.

### THURSDAY, DECEMBER 21.

**ROYAL SOCIETY OF MEDICINE** (Dermatology Section), at 5.

**INSTITUTION OF MINING AND METALLURGY** (at Geological Society), at 5.30.—**F. White**: Notes on the Correction required to Aneroid Readings for Altitude to counteract the Effect produced by the Diurnal Barometric Wave.—**P. C. Whitehead**: Some Notes on the Secondary Sulphide Enrichment exhibited by certain Auriferous Veins.

**CHEMICAL SOCIETY**, at 8.

### PUBLIC LECTURES.

#### SATURDAY, DECEMBER 16.

**HORNIMAN MUSEUM** (Forest Hill), at 3.30.—**H. N. Milligan**: Animals without Teeth.

#### THURSDAY, DECEMBER 21.

**CITY OF LONDON Y.M.C.A.** (186 Aldersgate Street), at 6.—**Sir John N. Jordan**: Some Chinese Problems.



# NATURE

A WEEKLY ILLUSTRATED JOURNAL OF SCIENCE.

*"To the solid ground  
Of Nature trusts the mind which builds for aye."*—WORDSWORTH.

No. 2773, VOL. 110]

SATURDAY, DECEMBER 23, 1922 [PRICE ONE SHILLING

Registered as a Newspaper at the General Post Office.]

[All Rights Reserved.]

## BALANCES & WEIGHTS

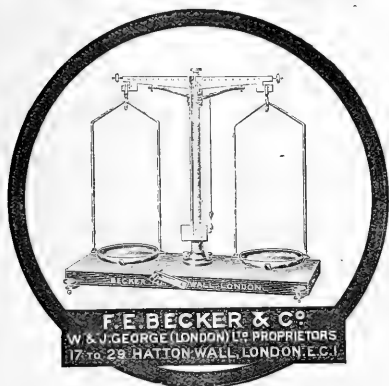

F. E. BECKER & CO

W & J. GEORGE (LONDON) LTD PROPRIETORS  
17 to 29, HATTON WALL, LONDON, E.C.1.

## REYNOLDS & BRANSON, Limited. "RYSTOS" STILL.

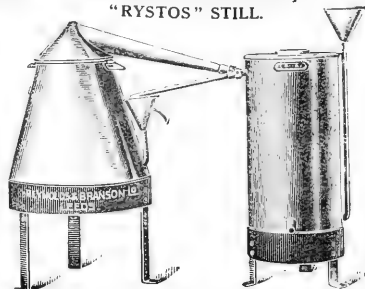

### Improved Central Flue Water Still and Condenser.

In this pattern the heat is conducted through the water by means of a central tube, ensuring economy of heating. The condenser worm is of pure tin, and the water jacket is air-cooled on two surfaces. One-gallon size (1 litre distilled water per hour), solid copper. Ring Burners for same. Price of various sizes on application.

Wireless Apparatus and Accessories supplied.  
Catalogue of Chemical Apparatus and Chemicals  
(New Edition), post free.

14 COMMERCIAL STREET, LEEDS.

## SPECTROMETERS

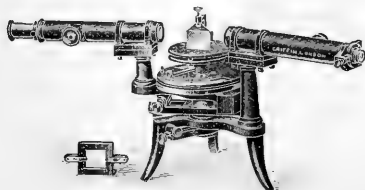

Particulars and Prices on application to—

JOHN J. GRIFFIN & SONS, LTD.

Kemble Street, Kingsway,  
London, W.C.2.

## WIRELESS APPARATUS

Complete sets in stock  
also———components

Call or write

NEGRETTI & ZAMBRA  
38, HOLBORN VIADUCT E.C.1.  
LONDON.

**NOTICE.**—In consequence of the Holidays the issues of NATURE for the weeks ending December 30 and January 6 may not be in the hands of Subscribers and others until Saturday, instead of Friday, as usual.

ST. MARTIN'S STREET, LONDON, W.C.2.

**A CHRISTMAS COURSE OF ILLUSTRATED LECTURES.**  
**ROYAL INSTITUTION OF GREAT BRITAIN,**  
 21 ALBEMARLE STREET, W.

Professor H. H. TURNER, D.Sc., D.C.L., F.R.S., will deliver a Christmas Course of Six Illustrated Lectures (adapted to a Juvenile Auditor) on "SIX STEPS UP THE LADDER TO THE STARS": "The Distance of the Stars," Thursday, December 28; "The Discovery of the Planet Neptune," Saturday, December 30, 1922; "Photographing the Stars," Tuesday, January 2, 1923; "The Spectroscope and its Revelations," Thursday, January 4; "Two Great Streams of Stars," Saturday, January 6; "The Size of a Star," Tuesday, January 9.

Subscription (for Non-Members) to this Course, Two Guineas; Juveniles between ten and sixteen years of age, Half-a-Guinea.  
 Subscription to All Courses of Lectures in the Session, Four Guineas. Tickets may be obtained at the Office of the Institution.

**BATTERSEA POLYTECHNIC.**  
 LONDON, S.W.11.

Principal—ROBERT H. PICKARD, D.Sc., F.R.S.

Full-time day courses for women preparing to be teachers of Domestic Subjects.

Preparation for posts as Institutional Matrons and Housekeepers and for colonial and home life.

Full-time day courses of training for Women Health Visitors and Infant Welfare Workers.

Evening courses of training for Sanitary Inspectors, Health Visitors, Meat and Food Inspectors, Smoke Inspectors, etc.

Day and Evening courses in Art, Music, and Domestic Science.

Hotels for Women Students. Large Athletic Ground and numerous clubs and societies.

**NATIONAL UNION OF SCIENTIFIC WORKERS.**

THE AIM OF THE NATIONAL UNION OF SCIENTIFIC WORKERS is to bring together into one professional organisation all qualified scientific workers, viz.:

Those engaged (a) In Higher Educational and Research Institutions.

(b) In Industry and Consultative Practice.

(c) In State and Municipal Scientific Departments.

Applications for membership are invited from all scientific workers with university degree or equivalent professional qualification. Further particulars may be obtained from

THE GENERAL SECRETARY, N.U.S.W.,  
 25 Victoria Street, S.W.1.

**CHELSEA POLYTECHNIC,**

CHELSEA, S.W.3.

Day and Evening Courses in Science under Recognised Teachers of London University.

- I. **INDUSTRIAL CHEMISTRY DEPARTMENT.**  
 Technical Courses in Analytical and Manufacturing Chemistry, Pharmacy, Food and Drugs, A.I.C. Courses, Metallurgy, Assaying, Foundry Work, Research.
- II. **INDUSTRIAL PHYSICS DEPARTMENT.**  
 Practical work in General Physics, Applications to Industries, Metrology, Calorimetry, Illumination, Acoustics, Electrical Measurement, Research.
- III. **BIOLOGICAL AND GEOLOGICAL DEPARTMENT.**  
 Courses for B.Sc., etc., in Botany, Geology, Mineralogy, Zoology, Special Courses in Bio-chemistry, Bio-physics, Bacteriology, Physiology, Hygiene, Entomology, Plant Pathology. Course for Tropical Planters, Research.

Let Term begins January 9, 1923.

SIDNEY SKINNER, M.A.,  
 Principal.

Telephone: Kensington 899.

**DORSET FIELD CLUB.**

AGRICULTURAL CHEMISTRY.

THE CECIL MEDAL and PRIZE of £10 will be awarded in May 1923 for the best Paper on "Recent Advances in Chemistry as applied to Agriculture, with special reference to Dorset conditions." Open to Persons aged 17-35, born in Dorset or resident One Year between May 1, 1921 and 1923.

Particulars from Mr. H. HOUNCY, Dorchester.

**THE QUEEN'S UNIVERSITY OF BELFAST.**

DEPARTMENT OF PHYSICS.

APPLICATIONS are invited for the LECTURESHIP in PHYSICS. Salary £450 per annum.

Particulars of the appointment may be had from

J. M. FINNEGAN, Secretary.

The Misses FARRAN

10 Bell Yard, Temple Bar, W.C.2,

HAVE CONSIDERABLE EXPERIENCE IN  
**COPYING SCIENTIFIC MS.**

AND ARE PREPARED TO  
 UNDERTAKE ANY QUANTITY.

**YOU CAN GET ANY  
 SCIENTIFIC BOOK  
 FROM  
 WHELDON & WESLEY, Ltd.**

2, 3, & 4 ARTHUR ST., NEW OXFORD ST., LONDON, W.C.2.

Telephone: GERRARD 1422.

If you are in need of any **SECOND-HAND BOOK** on  
**Natural History or Science** apply

**DULAU & CO., Ltd.,**

Established 1792.

34, 35, 36 Margaret Street,

Libraries purchased.

Cavendish Square, London, W.1.

**MESSRS. SOTHERAN**

have now opened a **Scientific Department** on the first floor of their Strand House, where a selection of their large stock in modern, as well as old and rare, works on **Exact and Applied Science** may be seen on the shelves.

They would also call attention to their facilities in getting sets or runs of periodicals on scientific subjects, as well as rare or out-of-print books they may not have in stock already.

HENRY SOTHERAN & CO., 140 STRAND, W.C.2, & 43 PICCADILLY, W.1, LONDON.



SATURDAY, DECEMBER 23, 1922.

CONTENTS.

	PAGE
The British Scientific Glass Industry	833
Our Nearest Living Relatives. By Sir Arthur Keith, F.R.S.	834
A Reflective Observer	836
Metallography in the Workshop. By H. C. H. C.	837
Mosquito Control. By Lt.-Col. H. J. Walton, I.M.S.	838
Our Bookshelf	839
Letters to the Editor:—	
A Quantum Theory of Optical Dispersion.—Prof. C. G. Darwin, F.R.S.	841
Interspecific Sterility.—Prof. J. P. Lotsy	843
Occult Phenomena and After-images.—Dr. E. N. da C. Andrade	843
A Relativity Paradox. (With diagram)—C. C.; Prof. A. S. Eddington, F.R.S.	844
The Track of a Flat Solid falling through Water. (Illustrated).—E. W. Wetherell	845
Water Snails and Liver Flukes.—R. H. Wallace	845
The Cause of Anticyclones.—W. H. Dines, F.R.S.	845
German Book Prices.—Prof. K. C. Browning	845
Medical Education.—Prof. W. J. Dakin; J. S. Dunkerly; J. T. Cunningham	845
Scientific and Industrial Pioneers.—Eng. Capt. Edgar C. Smith	846
W. H. Hudson Memorial.—R. B. Cunninghame Graham	846
Human Blood Relationships and Sterility.—Christopher Blayre; The Writer of the Article	846
Emission of Cathode and X-rays by Celestial Bodies. By Dr. Henri Deslandres	847
The Desensitising of Silver Bromide-Gelatin Plates. By Dr. T. Slater Price	849
Obituary	850
Current Topics and Events	852
Our Astronomical Column	854
Research Items	855
Photosynthesis	856
Progress in Engineering	857
Radio-Telephony and Broadcasting. By A. P. M. Fleming, C.B.E.	858
Excavations at Borg en Nadur, Malta	859
University and Educational Intelligence	859
Calendar of Industrial Pioneers	861
Societies and Academies	861
Official Publications Received	864
Diary of Societies	864
Supplement:—	
Pasteur. (Illustrated).—By Stephen Paget	iii
The Influence of Pasteur on the Development of Bacteriology and the Doctrines of Infection and Immunity.—By Prof. William Bulloch, F.R.S.	vi
Pasteur and Preventive Medicine.—By Prof. J. C. G. Ledingham, F.R.S.	viii
Pasteur in Crystallography. (With diagrams).—By Dr. A. E. H. Tutton, F.R.S.	viii
Pasteur's Early Research in Pure Chemistry and Fermentation.—By Prof. Arthur Harden, F.R.S.	xi
Pasteur and the Fermentation Industries.—By Prof. A. R. Ling	xii
Centenary Celebrations	xiv

Editorial and Publishing Offices:  
MACMILLAN & CO., LTD.,

ST. MARTIN'S STREET, LONDON, W.C.2.

NO. 2773, VOL. 110]

The British Scientific Glass Industry.

THE review of the development of the British glass industry, given by Prof. W. E. S. Turner recently in his presidential address to the Society of Glass Technology, throws new light on an industry which some have been inclined to think had to be largely created in this country after the outbreak of war. It appears that, even during the early days of its development in the seventeenth century, the industry made three notable contributions to manufacturing technique, namely, the use of coal instead of wood as a fuel, the introduction of covered melting-pots, and the preparation of lead crystal glass, which, in the course of time, ousted the famous Venetian glass from favour. Moreover, right through the nineteenth century, until about 1875, Great Britain held an important place amongst the glass-making countries of Europe, after which date its exports declined, due in a considerable measure to foreign tariff duties.

Prof. Turner shows something of the great revival of enterprise during the war period and afterwards, and of the extensiveness with which glass manufacturers have been installing new plant and machinery. In these phases of activity, no country in Europe can show a comparable record, and we may be permitted to indulge the hope that a brighter period lies before the industry than it experienced between 1875 and 1915.

In these columns we are interested mainly in the subject of scientific glass, and we have been forced to ask at times if the real position in regard to this branch has been understood or appreciated. Most divergent opinions on the merits of British scientific glass have been expressed. On one hand, very severe criticisms have been made of the quality of British scientific glass. On the other, we may say that we have seen letters, written spontaneously, testifying in glowing terms to its merits as compared with Continental glass; and inquiries in large laboratories have shown similar divergence of opinion, the balance of evidence being favourable. Possibly, users of scientific glassware have grown more critical of late years; they have been forced to this position partly by the prominence of the subject and partly by the financial stringency existing in scientific institutions. Moreover, the relations between the manufacturers and the dealers in this country appear not to have been of the most cordial character, and this fact cannot be ignored in estimating the chances of British ware in its claim to recognition.

It is interesting to contrast the beginnings of the chemical and scientific glass industry in the United Kingdom with the early operations at Jena. In our

own country both glass compositions and processes had to be extemporised in a great hurry, and it is indeed creditable to workers like Sir Herbert Jackson outside the factory, and Dr. M. W. Travers, Dr. C. J. Peddle, and Mr. John Kaye inside the factories, that glass vessels at least as durable chemically as any produced in Germany were forthcoming in so short a time. The earlier samples, just like those from Jena, when chemical ware was first made there in 1893, were far from being mechanically perfect. Processes and methods for the graduation of instruments had likewise to be worked out, and it has to be borne in mind that such work was in some instances taken up by persons who were more enthusiastic than competent. Many British people find it difficult to forget these early defects and have been ever ready to sigh for the return of German goods.

The work at Jena, which began about 1881, had ample time to be carried out systematically. The success of the work was due not altogether to the application of new elements to glassmaking but rather to the facilities for a great number of experimental meltings, some of them on a considerable scale, in which the influence of oxides, such as boric, zinc, barium, magnesium, and phosphoric, could be more fully investigated than had been the case by earlier workers. In this way there was gradually built up a series of definite relationships between chemical composition and physical properties, on the basis of which not only were new optical glasses devised but a new type of glass for laboratory use finally developed. Abbe himself was so impressed with the need of financial assistance in these undertakings and with the time consumed in carrying them out as to write: "The difficulties connected with such undertakings are so great, the initial outlay required is so heavy, and success if attained lies so far in the future, that there is little inducement to enterprise. A revolution of the industry can scarcely be brought about in any other way than by the means for its advancement being provided in liberal measure, either by corporations or public authorities."

Both scientific workers and manufacturers in the United Kingdom have well realised the truth of Abbe's remarks, and the user of scientific glass should also understand it. Since the war, despite the severe disappointment of the manufacturer in this country at the support given him, research has gone on continuously. A new type of chemical glassware has appeared on the British market, marking a departure in some ways from previous types and compositions, and as the results of extensive researches now in operation in this country become more and more complete, it is highly probable that still further types will be developed.

It is very likely that the Jena workers in later years acquired much systematic information that was never published. We have done very much here recently to revise the data which they have published and to show in some ways that it was defective and incomplete; while many other lines of research in this country, with the fundamental researches carried out in America, have given us resources of information which the German workers did not possess.

The very fact that, since the war, four new institutions, namely, the Department of Glass Technology at Sheffield, the Society of Glass Technology, the British Scientific Instrument Manufacturers' Research Association, and the Glass Research Association, have not only come into existence, but have also continued in full operation, affords convincing evidence that our manufacturers of scientific glassware are not content with their present attempts but are reaching out for something better. In this endeavour they are worthy of all the help and support, as well as patience, which the body of scientific workers can give them.

### Our Nearest Living Relatives.

*The Origin and Evolution of the Human Dentition.*

By Prof. William K. Gregory. Pp. xviii + 548 + 15 plates. (Baltimore, Md.: Williams and Wilkins Co., 1922.) n.p.

IT has so happened that Dr. W. K. Gregory, of the American Museum of Natural History, New York, and the writer of this review have each set out, at an early point in their lives, to seek for a definite answer to the same question: what is Man's lineage? Is he but a branch of the stem which gave the world its great living anthropoid apes—the gorilla, chimpanzee and orang—or must we carry our lineage into a remote geological past to find the point of its separate emergence from the primate phylum? The reviewer approached the problem by making an elaborate analysis of the structural "make-up" of man and of anthropoid apes, noting the kind and extent of their common heritage and the kind and extent of the structural features peculiar to each, which therefore may be regarded as latter-day acquisitions.

Dr. Gregory has sought an answer by following a totally different route. He has approached it by following the geological record; he has an unrivalled knowledge of the fossil remains of early forms of primates found so abundantly in the Eocene deposits of North America; and as teeth and jaws, or fragments of them, are the most persistent parts of the mammalian skeleton, it has come about that the geological history of the various orders of mammals has to be based on an interpretation of dental hieroglyphics. In deciphering

the ancient alphabet of the teeth, particularly as regards the teeth of primate forms, Dr. Gregory is our most highly trained expert. The survey he has now issued embraces not only the American tarsiod and lemuroid fossil-forms, lying in or near the basal phylum which has given us our modern apes and lemurs, but also includes an examination of the corresponding fossil forms found in Europe. He deals minutely with the fossil remains of apes found in the Oligocene deposits of Egypt, the anthropoid remains found in the Miocene and Pliocene deposits of Europe and of India—particularly those described in 1915 by Dr. G. E. Pilgrim, of the Indian Geological Survey,—and the various discoveries which have been made of fossil human remains.

Although the routes chosen by Dr. Gregory and by the reviewer have been different they have led to exactly the same goal—namely, that the gorilla, chimpanzee, and man are twigs growing from the same branch of the great primate stem. "Taken as a whole," writes Dr. Gregory, "the testimony of comparative anatomy affords cumulative evidence for Darwin's inference that *some ancient member of the anthropomorphous sub-group gave birth to man*. The detailed studies of the dentition in Part IV. of this work leads me to the conclusion that *the ancient member of the anthropomorphous sub-group* was closely allied to, or even identical with *Sivapithecus* or *Dryopithecus* of the Miocene Simiinae."

The reviewer agrees with Dr. Gregory that, on comparing the structural "make-up" of man with that of the great anthropoid apes, "the resemblances are far more numerous, detailed, and fundamental than the differences"; the reviewer would go further and say that in any theory of human lineage the common origin of man, the gorilla, chimpanzee, and orang, must be regarded as a "fixed point" in framing all our speculations. At this early stage in our search for man's pedigree, with only fragmentary documents at our disposal, and with yawning gaps in our book of evidence, complete unanimity between any two investigators cannot be expected.

In Dr. Gregory's opinion mankind is, in a geological sense, a recent product. So late as mid-Miocene times—about a million of years ago if we accept Dr. Gregory's rough estimate—he believes that our ancestry was represented by such fossil forms as *Sivapithecus* or *Dryopithecus*—which, so far as we yet know them, must be regarded as true anthropoid apes, not very different from the chimpanzee and gorilla. There is no ground for supposing that in foot or in brain they possessed any trace of the adaptations which have become so pronounced features of the human body. The life-periods and the rate of

reproduction of this ancestral stock must have been of the anthropoid order, namely, about seven generations to the century.

In the period postulated by Dr. Gregory for man's differentiation there would have been some 70,000 generations. The representatives of mankind we encounter by mid-Pleistocene times have already a brain which has three times the volume of the chimpanzee brain. Is it possible to conceive a brain like that of the chimpanzee, although constituted upon the same structural and functional plan as is the human organ, attaining a human standard in the course of 70,000 generations? It is true that the discoveries of Dr. Ariens Kappers have shown that the countless myriads of nerve units which make up the human brain are, during the period of development, controlled and grouped by a mechanism the nature of which we can only guess at as yet. Making all allowances on this score, the reviewer cannot conceive the possibility of the extreme structural and functional complexity of the human brain having been evolved from an anthropoid stage in the course of 70,000 generations. While Dr. Gregory is inclined to accept our present knowledge of the geological record at its face value and trace man's origin from an anthropoid of the mid-Miocene period, the reviewer would make allowances for the great blanks in our geological record, which further discoveries will make good, and assume a pre-Miocene date for the divergence of the phyla of man and great anthropoids. It is very difficult to believe that the human brain arose as mushroom-like growth.

Those who have made systematic attempts to determine the evolutionary relationship of one animal form to another know well that it cannot be settled on the evidence of one set of organs; all the structural systems of the body have to be taken into account. Often the evidence of one system—such as that of the teeth, which go with the alimentary system—will seem to clash with or contradict the evidence of other systems. Dr. Gregory is too experienced an evolutionist to make a mistake in this respect; whenever possible he supports or modifies the conclusions reached on dental evidence by appealing to testimony afforded by other systems of the body. Even when this is done it becomes abundantly clear that evolution has not worked on the body of man, ape, or of any animal form whatsoever in a simple and straightforward manner. For example, in that primitive but aberrant primate *Tarsius*, the embryo establishes itself in the maternal womb in exactly the same manner as do the developing ova of man and anthropoids, and yet the monkeys of the New and of the Old World, which have a simpler type of placentation, are yet infinitely

more akin to man and anthropoids in a structural and evolutionary sense than is *Tarsius*—in spite of this and other unexpected human likenesses possessed by the latter. To account for the irregular distribution of certain characters possessed by man and *Tarsius*, Prof. Wood Jones has put forward the claims of owl-eyed *Tarsius* to pose as one of man's near relatives.

The relationships of *Tarsius* to man, says Dr. Gregory, "are plainly very indirect and must be traced backwards along gradually converging lines to the primitive tarsoid stocks, which gave rise at different times and at different places to the higher groups of primates." As it has a bearing on such problems as the irregular distribution of the human mode of placentation among the primates, Dr. Gregory quotes with approval a principle enunciated by Dr. Henry Fairfield Osborn in 1908 and "familiar to all close students of mammalian phylogeny, namely, that identical characters are often developed by divergent descendants of a common stock." To the master morphologists of our studenthood days such a statement would have sounded heretical or metaphysical, but to those who are familiar with the complex mechanism of hormones, which regulate the growth of diverse structural elements so that they are moulded to serve a common functional purpose, this statement, made by one who has given a lifetime to the observation of fossil forms, has become of easy acceptance to those who are studying the development and growth of living forms. Our difficulties of accounting for the composite make-up of the human body and of that of his congeners, the anthropoid apes, will disappear once we have mastered the growth mechanisms which lead to the creation of structural modifications and the suppression and perhaps resuscitation of old features.

The reviewer has merely noted here the chief conclusions which years of careful toil have permitted Dr. Gregory to formulate concerning man's origin. The main value of the work he has now published is to provide students of the higher mammalian forms with an indispensable dictionary for the interpretation of dental hieroglyphics. Out of a restricted alphabet, Nature has fashioned teeth into a most elaborate and significant language. How these elements are manipulated so as to provide a profusion and variety of dental forms we do not know but it is clear to the least initiated that upper and lower teeth have to be so fashioned, while still embedded in the gums, that when they come into place in the jaws they will fit each other just as a key does its lock. There must be a correlating mechanism at work to harmonise the bite of opposing cusps. Of this Dr. Gregory is fully cognisant, but we regret that he has not abandoned the confusing system of naming the cusps of molar

teeth introduced by Dr. Osborn. In this system the names given to the cusps of upper molar teeth are reversed when applied to the cusps of lower teeth—a method with all the perplexing attributes of a reflected image. Besides, as Dr. Gregory has frankly admitted, the system, which has served a good purpose in its time, is really founded on an erroneous interpretation.

Another small and personal grudge the reviewer may also give vent to—the introduction of the new-fangled nomenclature for the old and well-established generic names we have hitherto been accustomed to give to apes and monkeys. But the reviewer's last words must be those of admiration and of thanks for a standard work.

A. KEITH.

### A Reflective Observer.

*A Philosopher with Nature.* By Benjamin Kidd. Pp. vii + 211. (London: Methuen and Co., Ltd., 1921.) 6s. net.

MR. BENJAMIN KIDD was a keen observer of Nature, particularly interested in the problems of animal behaviour and all that throws light on evolution. This volume is a collection of his essays; with the exception of the first two, which deal very attractively with the birds of the Severn estuary, they have been previously published in serials. But in collected form they are very welcome. In all cases there is a characteristic reflective note: What is the deeper significance of this or that occurrence? The primitive language, among birds for example, is undoubtedly a language of the emotions, but it is interesting to notice that it is often a kind of *lingua franca* understood even by widely different species. The young of the mallard, which has probably been the most universally hunted creature on earth, nestle on the observer's bare feet without the slightest instinctive fear. "You take one of them in your hand, and this heir of the ages of the blood-feud shows no fear of you, even tilting its little beak to look inquiringly in your face; evidently thinking no evil, to all appearance hoping all things and believing all things, but certainly quite willing to take you on your merits for good or evil entirely without prejudice." The mother bird is on a tussock near by, "chattering with emotion, every feather quivering with excitement. The hold of the Great Terror of Man is upon her. In a few days, nay, in a few hours, she will have taught it to them, and they will have passed irrevocably into another world." Character is a product of "Nature" and "Nurture."

An interesting experiment was made with a colony of humble-bees which Mr. Kidd kept on his window-

sill. He carefully removed part of the waxen covering of one of the little groups of larvæ, inserted a grub taken fresh from a hive, and covered the whole again roughly, "expecting that the bees would complete the repairs, and so seal up the intruder with the others. But they were not to be cheated in this way, and they would not repair the broken wax until they had smelt out the stranger, whom they dragged out and carried outside the nest, after which they replaced the breach in the usual way." He made the experiment several times, but with no better success. He then placed some hive-bee eggs among a little group just deposited by the humble-bee queen. The bees seemed to be rather puzzled. "One or two of them took them up somewhat aimlessly, and again replaced them as if they hardly liked to openly accuse their sovereign of misconduct, which they seemed to suspect." After some hesitation they proceeded, apparently with considerable relish, to eat the eggs. "So appreciative did they become of the flavour of these new-laid eggs that they would soon accept them readily when I offered them at the end of a needle."

Observations on a captive queen humble-bee supplied with an empty nest were also interesting. She spent several days beating against the window-pane and then gave it up entirely; she showed great interest in brightly coloured objects like brass handles, gilt labels on books, and waistcoat buttons. But she was particularly intrigued by the keyhole of the door, into which she would try to squeeze herself. Apparently it "suggested" the opening into an underground nest.

In the essay on hares there is an interesting paragraph. "It is a moot question whether the hare is a rabbit which has taken to the open or the rabbit a degenerate hare which has obtained comparative safety by taking to a stupid life in the earth. It is an interesting fact in this connexion, and one not often remarked on by observers, that a hare, if it finds an obstacle it wishes to get rid of, will naturally scratch with its front legs with considerable strength and with exactly the same movement as a rabbit. Thus, although the hare lives in the open grass country, never takes to earth, and much dislikes ground infested by rabbits, it has to all appearance latent in its muscles the beginning of an instinct which might be developed into the rabbit's capacity for burrowing."

Of its kind the picture of a midsummer night is difficult to beat; it is as well drawn as Richard Jefferies could have done it. Take the sounds: the churr of the night-jar, calling to his mate; the undertone of the hundred rills and the swollen river; the warning stamp of rabbits that have been disturbed in their feeding; the strident love-note of the corn-

crake; the shrill cry of the partridge; the nightingale singing to his mate on her nest; and then the larks, the thrushes, the twittering swallows as the fringes of the night overlap the coming day. It is not merely a well-drawn picture; it is a reflective appreciation.

What Mr. Kidd has to say about animal behaviour is always interesting. Obeying the law of parsimony he will press the simplest re-description as far as it will go, and yet he cautions us that "the more the subject is closely studied the less the observer finds himself inclined to accept ready explanations." A young sheldrake, fed on dry ground, went through a kind of dancing or prancing movement, stamping rapidly on the floor with its feet. Darwin connected this with the sheldrake's habit of patting the sand or mud near the worm-burrows on the seashore flats. The stamping is supposed to "make the worm come to the surface," and so the sheldrake keeps on stamping. But Mr. Kidd points out that it is the way of young wild duck in general to stand in the shallow water and stamp gently and rapidly on the muddy bottom. This makes an eddy bringing up food-particles which are then seized and devoured. Three-days-old ducklings, hatched under a domestic hen, exhibit the movements to perfection. Perhaps the sheldrake's stamping is merely a slight modification of a piece of instinctive behaviour general among ducks. But in the opposite direction, Mr. Kidd makes out a good case for refraining from any simplistic interpretation of the behaviour of a collie dog. We fail utterly unless we take into account its ancestry, for it was one of a pack, a social unit. "The dog has probably still some sort of conception of his place as member of a co-operative group, and of his master as the wise and resourceful leader of it." The other essays discuss sea-trout, eels, frogs, birds, squirrels, and the like. All are illuminating and all are delightful.

### Metallography in the Workshop.

*Steel Thermal Treatment.* By J. W. Urquhart. Pp. xv+336. (London: Crosby Lockwood and Son, 1922.) 35s. net.

NEARLY all the books which have hitherto been written on the heat treatment of steels are the work of metallurgists. The interesting thing about the present work is that it has been written by a man engaged in the production of machinery and various steel components and tools in his workshops in Leicester. As he states, he has been forced to put into practical use all the recently introduced processes employed in

the heat treatment of steel. Many other tool makers have been in the same position. It has, however, been left to Mr. Urquhart, not merely to make a study of the processes involved, but to write a book on them from a practical engineering view-point. In doing this he has rendered a service to his brother engineers which they will probably not be long in recognising, for he has written his book in language which is as free from technicalities as possible.

The time has gone by when steels as received from the makers were forthwith worked into machines, without any preliminary treatment, and when it was not realised that a thermal process could add enormously to their physical strength and effectiveness. In consequence there has been a revolution in the engine and machine building trades within the last few years, which is only realised by the men engaged in those trades. As the author points out, not only have great improvements been introduced in the treatment of well-established carbon steels, but they have been followed by a remarkable development in the use and heat treatment of alloy steels. These advances have necessitated the application of better systems of applying heat and measuring the temperatures produced, and these in their turn have led to the introduction and development of electrical methods of heating, which are capable of a higher degree of control and accuracy.

The early chapters of the book deal with the recent developments in metallography as applied to steels. The author has mastered the theory of the iron-carbon equilibrium, as applied to both carbon and alloy steels, and this is one of the best parts of the whole book. As he points out, one of the most remarkable effects of alloying nickel with mild steel is the lowering of the temperature of the A<sub>1</sub> range, an effect which means diminished cost of working the steel, a greater margin of safety against over-heating, increased ductility, toughness, and resilience in the finished product. The physical characteristics of steels and testing methods are next described, and these are followed by an outline of thermal processes. Chapters on furnaces and their methods of working come next, and a very good account is given of pyrometers and their application to the thermal treatment of steels. Methods of case-hardening, both by solid and gaseous reagents, are next described, and these are followed by details of the various methods of quenching. Later chapters deal with various types of tools and typical heat treatments, and in the last two chapters accounts are given of the thermal treatment of high-speed tool steels and stainless steels.

To some extent the book is an attempt to co-ordinate the work of the laboratory with that of the engineer's

hardening department; and with this end in view, the author has included a series of photomicrographs illustrating the structures of steels at various stages of heat treatment under workshop conditions. He has availed himself of the experience of well-known metallurgists, such as M. Guillet and the late Prof. Howe on the academic side, and of Sir Robert Hadfield, Mr. S. Brayslaw, and Prof. Giolitti on the practical side. There is no doubt that the volume will be widely welcomed by practical men, and it should do much to raise the standard of the scientific heat treatment of tools and machine parts.

H. C. H. C.

### Mosquito Control.

*Mosquito Eradication.* By W. E. Hardenburg. Pp. ix + 248. (New York and London: McGraw-Hill Book Co., Inc., 1922.) 15s.

IN this small book the author gives a clear and concise account of the measures which have been found successful in controlling mosquitoes in America. The brilliant results of the anti-mosquito work in Havana and the Isthmus of Panama have been fully appreciated in the United States. Dr. G. A. Le Prince, formerly Chief Sanitary Inspector, Isthmian Canal Commission, wrote, in the Annual Report, U.S. Public Health Service for 1920, "The public view-point has changed; villages, towns, county and state officials, as well as business corporations and railroads, now realise the extent of the large preventable financial loss they incur each year. . . . The people have been watching the campaigns undertaken, and throughout the country they are becoming more and more interested in having their own community and state undertake this work. . . . This calendar year, 101 places are doing work under the supervision of the Public Health Service, and have already appropriated \$280,000 therefor."

The modern methods of mosquito control are merely elaborations of those originated by Sir Ronald Ross in the East and by General Gorgas in the Canal zone and Cuba; they have already been described very graphically by Le Prince and Orenstein. But Mr. Hardenburg, who is a sanitary engineer, has treated the subject from a somewhat different point of view from that adopted in "Mosquito Control in Panama." Descriptions are given of the more important American culicine and anopheline mosquitoes. These, though brief, are sufficient to enable a sanitary officer to recognise most of these insects that he is likely to meet with; the information given in the body of the book is supplemented, in an appendix, by a more technical key for the identification of both larvae and adults.



A good account is given of the preliminary survey work that has to be done before actual operations against the mosquitoes can be commenced. Mr. Hardenburg insists upon the importance of a vigorous propaganda to arouse public interest, and explains, with some humour, how to induce newspaper editors and the "motion picture houses" to "boost" the work.

Drainage of swamps, pools, and salt marshes is dealt with very thoroughly; and detailed directions are given for the construction of drains by handwork or by machinery, for the laying out of a system of tile drainage, and for the construction of tide gates and sluices.

The use of oil and other larvicides, with its advantages and disadvantages, is fully considered; and a whole chapter is devoted to the use of fish to control the mosquitoes. The author writes with enthusiasm on this latter subject, but adopts a more judicial attitude towards the proposal to establish "bat-roosts." The problem of how to deal with the mosquitoes which breed in rice-fields seems to be still unsolved, at least in countries where the people insist upon having rice cultivation near the villages. The habits of the different species of Anopheles, and especially their choice of breeding-places, are so varied that experience gained in one country is not sufficient for dealing with the conditions met with elsewhere. Now, however, thanks to this book, to that of Le Prince and Orenstein, and to Dr. Malcolm Watson's "Prevention of Malaria in the Federated Malay States," public health officers in the tropics are well provided for.

Mr. Hardenburg's book represents the views of a practical man. It can be recommended with confidence to all those who have to deal with sanitation in malarious countries.

The value of the book is much enhanced by the many excellent illustrations with which it is adorned.

H. J. WALTON.

### Our Bookshelf.

*Das feinbauliche Wesen der Materie nach dem Vorbilde der Kristalle.* Von Prof. Dr. Friedrich Rinne. 2 und 3 erweiterte Auflage. Pp. viii+168. (Berlin: Gebrüder Borntraeger, 1922.) 10s. 4d.

THE new edition of Prof. Rinne's book is considerably larger than the first edition, and presents an altogether wider outlook on the fine structure of matter as exhibited in crystals. The whole work is enriched by an originality of treatment which renders it eminently readable and suggestive. Moreover, the excellent portraits of von Groth, Häuy, Schoenflies, Fedorov, Tschermak, von Laue, Debye, Scherrer, Sir William Bragg, and W. L. Bragg give it an altogether special interest. A reproduction of Albrecht Dürer's picture "Melancholie" is also given, in which the representation of a huge crystal occupies a prominent

place, the inference being that Dürer was oppressed by the idea of the hopelessness of man's ever rising to the comprehension and explanation of a natural phenomenon so wonderful and remarkable as that of crystallisation. If Dürer lived to-day, however, how different would be his picture! Its title might well be "Hope," or even "Achievement," rather than "Melancholie."

It is this extraordinary success of recent crystallographic and physical research, and particularly that brought about by the use of X-rays in elucidating the arrangement of the chemical atoms in crystals, that forms the main theme of Prof. Rinne's book, and he regards the whole achievement in its more fundamental aspect, as having revealed the true nature of the fine-structure of solid matter. The book is full of illustrations and diagrams of an original character, including many of the X-radiograms of crystals due to Prof. Rinne's own industry. It is a book of very special merit, and one of the most suggestive and far-seeing that have appeared since the inauguration of these fruitful new methods of research. A. E. H. T.

*Elementary Hydraulics for Technical Students.* By Prof. F. C. Lea. Pp. vii+224. (London: E. Arnold and Co., 1922.) 7s. 6d. net.

DR. LEA'S larger work on hydraulics has long been regarded as an authoritative treatise, and the present volume will be welcomed by many who have felt the need for a less comprehensive work. Beginning with clear accounts of fundamental principles, the questions of the flow through orifices and over notches and weirs are discussed. Next follow the flow through pipes and channels and the methods of gauging the flow of water. Vanes, water-wheels, turbines, and pumps are then considered, and the volume closes with a chapter on hydraulic machines. The treatment throughout is simple, which will render the book suitable for use in technical schools; the drawings are well executed, and the text is very readable. A commendable feature is the description of many experiments which may be carried out on a comparatively small scale with inexpensive apparatus. Any student who works systematically through the experiments described will gain a very fair working knowledge of the methods employed and of the manner in which the results are reduced. The book also contains a number of well-selected exercises, with answers; to some of these exercises hints are appended for their solution, while others are left to the student. Hydraulics is not an easy subject to author or student, and Dr. Lea is to be congratulated upon the present volume, which cannot fail to be of service to both teachers and students.

*The Czechoslovak Republic.* By Jaroslav Císar and F. Pokorný. Pp. vi+218. (London: T. Fisher Unwin, Ltd.; Prague: Orbis Publishing Co., 1922.) 9s. net.

THE authors of this volume aimed at compiling a complete handbook to the new state of the Czechoslovak republic and have published an English edition in the hope of spreading a knowledge of their country. There are chapters on the history, topography, population, political organisation, natural resources, industries, trade, transport, etc., with appendices of statistics

and a well-printed, if rather small-scale coloured map. The notes on topography are very brief, covering scarcely two pages, while climate is dismissed in a few lines. More consideration of these fundamental aspects of the economic life of the country would enhance the value of the book.

Of all the new or newly constituted states of Europe probably none has greater possibilities than Czechoslovakia. Its central situation, varied resources, and rich mineral endowment combine to promise a bright future. Racially also it has fewer thorny problems to solve than most of the new states. Czechs and Slovaks together comprise 68 per cent. of the population, and the only considerable non-Slavonic element is 22 per cent. of Germans, mainly in Bohemia. At the same time the great difference in cultural status between the Czechs and Slovaks, which is emphasised by the comparative lack of communication between their respective countries, is a hindrance to the consolidation of the State. The government is fully aware of this difficulty, and is facing it by the improvement of communications. The section of the Elbe from Aussig to Neratovice has been canalised and operations are in progress as far as Pardubice. From there a canal, 110 miles long, will be built to Prerau on the Bečwa in Moravia. A Danube-Oder canal is also under consideration.

R. N. R. B.

*Technical Electricity.* By H. T. Davidge and R. W. Hutchinson. Fourth edition. Pp. xii + 514. (London: University Tutorial Press, Ltd., 1922.) 10s. 6d.

THE object of the authors of this volume is to give a clear exposition of physical principles and to show how they are applied in engineering practice. This is done satisfactorily, and we think that the volume will prove useful to engineering students in the first and second year of their course at a technical college. Engineering practice and phraseology change rapidly, so it is difficult to keep an engineering treatise absolutely up-to-date. For example, the phrase "mean spherical candle-power" is rapidly becoming obsolete. Engineers now use the much more sensible phrase "the average candle-power"; similarly a "half-watt" lamp is now termed a "gas-filled" lamp. It is not strictly correct to say that the international candle-power "is now defined as an illuminating power equal to one-tenth of that of the Harcourt-Pentane lamp." When engineers refer to the international candle they mean the unit of luminous power maintained by the National Physical Laboratories of France, Great Britain, and the United States of America. The Hefner-kerze is used by Germany and Austria, and its numerical value is nine-tenths of that of the international candle. Hence the candle-powers given by lamp manufacturers in Germany are expressed by larger numbers than if they were expressed in international units. This is to their commercial advantage. We were surprised that the international standards for the resistance and temperature-coefficients of pure annealed copper are not given, as they are of fundamental importance in electrical engineering. We hope that the wire gauges, the table for the resistance of copper wires (temperature not stated), and the tables of fusing currents will be omitted from the next edition.

*Notes on Qualitative Analysis: Concise and Explanatory.*

By Dr. H. J. H. Fenton. Supplement. Pp. v + 155-202. (Cambridge: At the University Press, 1922.) 3s. 6d. net.

THIS pamphlet forms a supplement to Dr. Fenton's well-known "Notes on Qualitative Analysis." The more important and characteristic reactions are given of the rarer elements of more general interest which can be identified by chemical tests. References to "spectra," without any details, are made. No description is given of possible methods of separation. In arranging the elements according to alphabetical order, their chemical relationships are quite obscured, and the information conveys the impression of isolated snippets. The selection of the inorganic and organic compounds is, as the author emphasises, quite arbitrary: one notices more particularly the substances studied by Dr. Fenton himself. Although the book may prove useful to teachers who have not access to the larger treatises, its lack of system and reasonable completeness will somewhat diminish its value as compared with existing manuals of qualitative analysis such as that of Treadwell.

*The Fishing Industry.* By Dr. W. E. Gibbs. (Pitman's Common Commodities and Industries.) Pp. viii + 135. (London: Sir I. Pitman and Sons, Ltd., 1922.) 3s. net.

A VERY concise and comprehensive account of the sea-fishing industry in general is contained in Dr. Gibbs's little volume. There are chapters on the natural history of the edible fishes, molluscs, and crustacea, and on the methods of fishing, but the distinctive parts of the book are those that deal with the mode of fish-curing and conservation, and with the utilisation of by-products. Written with an evident personal knowledge of the processes described, these chapters make a really important contribution to the literature of the sea fisheries. J. J.

*Manuel d'océanographie physique.* Par Prof. J. Rouch. Pp. 229. (Paris: Masson et Cie, 1922.) 15 francs.

CAPT. ROUCH'S book is a well-balanced account of oceanography, treated almost entirely from the physical point of view. The first part deals with methods, soundings, the physics and chemistry of seawater, the study of currents, tides, and tides and the observation of ice-formation. The second part deals in the usual way with the general results of oceanographical investigation. The book is a small one, but it is very concise in its treatment, and it is well illustrated.

*Practical Tanning.* By Dr. Allen Rogers. Partly based on the Third Edition of "Practical Tanning," by Louis A. Fleming. Pp. xxv + 699. (London: Crosby Lockwood and Son, 1922.) 45s. net.

DR. ROGERS is well known for his writings on chemical technology, and as an account of recent American practice his book will prove interesting to English technologists. It deals briefly with all branches of the subject, and is illustrated. The section on analytical methods is brief, but most of the important determinations are covered. A short account of synthetic tanning materials is given.

## Letters to the Editor.

[The Editor does not hold himself responsible for opinions expressed by his correspondents. Neither can he undertake to return, or to correspond with the writers of, rejected manuscripts intended for this or any other part of NATURE. No notice is taken of anonymous communications.]

## A Quantum Theory of Optical Dispersion.

WHEN a theory is framed trying to explain a discrepant system of facts, it is a necessary process of thought to take some branch of the theory as more completely true than the rest, and to adjust the remaining parts in such a way that they will fit in with this base, though they may still conflict with one another. This has certainly been true of the quantum theory; the speculations connected with it have as their base the law of the conservation of energy. Now a critical examination of fundamentals does not by any means justify this faith. It is, of course, a fact of observation that, in the gross, energy is conserved, but this only means an averaged energy; and as pure dynamics has failed to explain many atomic phenomena, there seems no reason to maintain the exact conservation of energy, which is only one of the consequences of the dynamical equations. Indeed it is scarcely too much to say that had the photoelectric effect been discovered a century ago it is probable that no one would ever have suggested that the status of the first law of thermodynamics was in any way different from that of the second. On the other hand, Bohr's theory, and especially Sommerfeld's extension of it, have given great encouragement to the belief that in dynamics lay the way to the complete truth, so that in consequence of the triumphs of that theory there has been little thought in other directions. Another impediment is that our whole ideas are saturated with the principle of energy, so that denying it leaves scarcely any foundation from which to start.

Now there is another field of phenomena which forms a consistent whole, but at present only fits into the quantum theory with a good deal of difficulty—that is, the wave theory of light. Interference and diffraction are completely explained by a wave theory, and it would seem almost impossible to devise any really different alternative which would account for them. Here is a base which seems to be free from the objections which attach to energy, and I have therefore been examining the consequences of fitting it in with those parts of the Bohr theory which seem to be most completely established. The result is what I believe to be a satisfactory theory of dispersion—one of the weakest points in the quantum theory<sup>1</sup>—and a great promise of future extensions in other directions.

We shall assume then that the wave theory gives a correct account of events *outside matter*, and it is convenient to take over the terminology of the electromagnetic theory, provided we remember that "electric force" is only to mean "light vector," and that we are not prescribing how the electric force will affect the behaviour of atoms or electrons. The assumption brings with it of course the exact conservation of energy in the æther; it is in interchanges with matter that it need not be conserved. When a wave passes over matter there is a mutual influence, and without any inquiry into what happens to the matter, we can say that it is inconceivable that the effect on the æther should be anything

but in the form of an expanding spherical wave. Every such wave can be described in terms of spherical harmonics, and the simplest is the one corresponding to the harmonic of zero order. In this the electric force vanishes at two poles and is elsewhere along the lines of longitude and proportional to the cosine of the latitude, while the magnetic force lies in the circles of latitude. This is the type of wave given in the classical theory by a Hertzian doublet vibrating in a line, and it proves unnecessary for our theory to postulate that any more complicated type is emitted by the atom. If  $x$  is the direction of the pole of the wave, then at  $x, y, z$ , at a great distance  $r$  from the atom, the wave is given by:

$$\left. \begin{aligned} E_x &= -\frac{r^2 - x^2}{r^3} f(t - r/c) \\ E_y &= \frac{xy}{r^3} f(t - r/c) \\ E_z &= \frac{xz}{r^3} f(t - r/c) \end{aligned} \right\} \quad (1)$$

Next, borrowing from the Bohr theory, we shall assume that when an atom is struck by a wave, there is a certain chance that the atom should emit a secondary wave of the above type. With these assumptions it is possible to argue inductively from the observed fact that if incident waves are superposed the result can be found by an addition of their effects and from the known form of the dispersion formula. There is no need to give the argument, but only its final result. The complete statement of this for unpolarised waves is rather more complicated, but the essential points of the theory are fully represented in what follows.

When a wave, polarised so that the electric force is along  $x$ , strikes an atom at the origin there is a chance  $A_n \cdot (\partial E_x / \partial t) dt$  that in the time  $dt$  it will excite the atom to emit a spherical wave of the type (1) with  $f$  of the form  $a_n e^{-\lambda_n s} \cos k_n s$ . Here  $A_n, a_n, \lambda_n$ , and  $k_n$  depend only on the nature of the atom and not at all on the incident force;  $\lambda_n$  is supposed to be small. Of course  $\partial E_x / \partial t$  may be negative; in this case we shall suppose that there is a chance  $A_n (-\partial E_x / \partial t) dt$  for the emission of a wave  $-f$ . We shall be able to treat both cases together and need not make the distinction. The subscript  $n$  indicates that we suppose there are several different ways in which the atom may be excited, each with a separate chance for it.

Consider a simple case, a monochromatic wave polarised along  $x$  and advancing along  $z$ , which strikes a group of  $N$  atoms at the origin. Let the wave be  $E_x = H_y = F \cos \phi(t - z/c)$ . The number excited in the interval  $dt$  will be  $NA_n (-F \phi \sin \phi t) dt$ . Consider the secondary wave crossing the point  $x, y, z$ , at the time  $t + r/c$ . This is due to all the atoms which were excited before the time  $t$ . The number excited in the interval  $ds$  at a time  $t - s$  is  $-NA_n F \phi \sin \phi(t - s) ds$  and each of these will at the time  $t$  be giving a wave typified by  $f = a_n e^{-\lambda_n s} \cos k_n s$ . So the total effect will be a wave which at the time  $t + r/c$  at  $x, y, z$  has an  $x$ -component

$$\begin{aligned} E_x &= -NA_n F \phi \left( -\frac{r^2 - x^2}{r^3} \right) \int_0^\infty \sin \phi(t - s) ds \cdot a_n e^{-\lambda_n s} \cos k_n s \\ &= NA_n a_n \frac{r^2 - x^2}{r^3} F \frac{\phi^2}{k_n^2 - \phi^2} \cos \phi t, \end{aligned} \quad (2)$$

provided that  $\lambda_n$  is taken as small. The averaging has entirely blotted out the frequency of the atoms and left only that of the incident wave. Now on the classical theory, if there is a group of  $N_n$  electrons

<sup>1</sup> The difficulty is that the standard theory indicates a dispersion formula involving the frequency of the electron's motion in the atom which is quite different from its absorption frequency.

which have a natural frequency of vibration  $h_n/2\pi$ , the wave they scatter is given by

$$E_x = N_n \frac{c^2}{mc^2} \frac{v^2 - x^2}{v^2} F \frac{p^2}{h_n^2 - p^2} \cos pt.$$

So if we identify  $N_n e^2/mc^2$  with  $NA_n a_n$  the expressions are the same. But the only difference between the phenomena of scattering and of the refractive index lies in the matter of allowing for the mutual influence of the atoms, an influence exerted by the waves they send out and therefore the same on both theories. So we may at once say that from our result will follow the dispersion formula of Lorentz

$$\frac{3(\mu^2 - 1)}{\mu^2 + 2} = \sum_n \frac{4\pi N_n c^2 A_n a_n}{h_n^2 - p^2}$$

From the linear way in which the chance of excitation depends on the incident force, it follows that the average effects of superposed waves is additive; in other words, the atoms act as Fourier analysers, sort out the harmonic components of an arbitrary incident wave and refract each component in the proper degree. In all cases the characteristic frequency with which the waves are really emitted will entirely disappear by averaging.

It will be necessary to consider the balance of energy which is nearly but not quite exact, but the present simple equations are not suited for this; they fail to give the balance even in the classical case, and there it must occur. This question is better treated in connexion with absorption. The problem is complicated by the fact that the excited wave may possibly have a phase differing slightly (it may only be slightly) from that of a cosine. I have assumed the form of the damping factor as  $e^{-\lambda t}$  only for convenience; all that is necessary is that the infinite end should be unimportant. An alternative is to suppose that the wave is undamped but that there is a chance  $\lambda_n dt$  in every element of time  $dt$  that it should stop. We have only discussed waves polarised along the  $x$ -axis and have supposed that the excited waves have this axis as pole; for the general case the formulation must be somewhat changed, but it would take too long to state and prove the modification here. The essential points of the theory are not altered, and it also appears that there should be no particular difficulty in fitting double refraction and rotatory dispersion into our scheme.

A theory of dispersion is not of course complete without including selective absorption. If  $\lambda_n$  is retained in the integration of (2) the result is an expression practically the same as that given in the classical theory when a damping factor is included. Observe that on the present theory, when the forced period approaches the natural, there is no increase either in the number of atoms excited or in the strength of the waves they send out. The whole change is due to the greater efficiency with which they reinforce the primary beam. Our theory gives no explanation of the mechanism of conversion of radiant energy into atomic heat, any more than does the classical theory with its damping factor. The conversion is probably better studied by the consideration of other cases of absorption, such as metallic reflection, and our method of argument, applied to this last, should certainly give interesting results. We shall have to find what emission of spherical waves will diminish the æthereal energy when superposed on the incident wave. Thus a wave like that for dispersion would do for metallic reflection, if the phase is suitably altered, or possibly we may suppose that the wave is again in the form

of a cosine, but that the chance of excitation is now proportional to  $E_x$  instead of to  $\partial E_x/\partial t$ . It seems likely that a study of the optical constants of metals would throw light on this question. Afterwards it would be necessary to examine the balance of energy between æther and matter, and this might help in understanding the mechanism of the process.

We may now review how these speculations will modify the accepted theory. As we have made no assumptions as to what goes on inside the atom, we can take over the whole of the dynamics of stationary states. We suppose that an atom is usually in its lowest quantum state. The motions of the electrons will sometimes lead to a favourable configuration, and when this occurs in the presence of a changing electric force, there is a chance that the atom may be jerked into a condition in some way associated with one of its higher quantised states. It at once starts radiating with a frequency corresponding to the return from that state to the lowest. Dispersion throws no light on the amplitude of the wave, for in the formula it always occurs multiplied by the probability factor  $A_n$ . It is rather tempting to suppose that it actually goes into the higher quantised state, and then gives a wave of such amplitude and length that, but for the interference with the incident light, it would emit energy  $hh_n/2\pi$ . If this is so we may perhaps extend our theory to cover pure emission; for, though we have not postulated any precise relationship between electric force and electrons, it seems inevitable that there should be a rapidly changing electric force near a moving electron, and this force would have a chance of jerking the atom into its higher state. On the other hand, difficulties are raised in other directions. For the radiation must be immediate and therefore the state would not really be stationary at all, and the accepted theory of specific heats requires that a molecule should be able to remain in its higher states. In any case there is a clear contradiction to the principle of energy, but the phases of the outgoing waves are so adjusted that for cases of pure scattering or refraction, on the average, as much energy goes out as comes in.

There are many other points that will require attention. In the first place the refractive index is closely related to the dielectric constant. Now though it is quite proper to treat the dielectric constant as a limiting case of refraction, yet it can be regarded electrostatically and it will be necessary to see the physical meaning of this aspect. Again it is possible to count the electrons in the atom by X-ray reflection, and it follows that there must be a relation between the  $e^2/mc^2$  of the classical theory and our  $A_n a_n$ . In this connexion I owe to Prof. P. S. Epstein the suggestion that the theory will explain the defect observed in the scattering of hard  $\gamma$ -rays below that predicted. Here the wavelength of the incident light is much shorter than the distances between the electrons and the incoherent waves cannot recombine in the way they do under the classical theory. Lastly, it will be necessary to re-examine the deduction of the formula for black radiation, for all present proofs are founded on theorems following out of the conservation of energy.

In view of the great number of problems that are suggested and the probability that it will take a considerable time to deal with them, it appeared to me that it might be of interest to publish this preliminary account of a very incomplete theory.

C. G. DARWIN.

Institute of California,  
Pasadena, Cal.

### Interspecific Sterility.

DR. BATESON'S letter on interspecific sterility in NATURE of July 15, p. 76, has given rise to an interesting discussion in later issues, which may be summarised thus:—

Sterility between wild species is not nearly so common as was formerly supposed, yet it undoubtedly occurs frequently, both between species with the same number and with different numbers of chromosomes. The cause of this sterility has not yet been made out with any degree of certainty. On the other hand, crosses between domestic races are, almost exclusively at least, perfectly fertile, although Dr. Gates rightly points out that sterility may often be expressed in lethal factors and that lethal factors are of common occurrence in Morgan's "domestic" races of *Drosophila* for instance.

Dr. Bateson's starting-point is his belief, that domestic races as well as species in Nature have arisen by some process of transmittable variability, let us say by mutation. At least, on no other assumption can I explain his sentence (*l.c.* p. 76):

"In contemporary variation we witness the origin of many classes of differences, but not this (*e.g.* interspecific sterility); yet by hypothesis it must again and again have arisen in the course of evolution from species of a common origin."

Geneticists are aware that this view is not mine. According to my view two genotypically different gametes are required to give rise to new forms: domestic races as well as natural species arise by crossing. If this is the case—and nobody will deny that, at least in the production of "races," crossing plays a most important rôle—there is no cause to assume that sterility has ever "arisen" from fertility in the course of evolution. We have, for the present, to be satisfied with the establishment of the fact that some gametes, differing in constitution, after crossing give rise to wholly or partly sterile progeny, while others give fertile progeny only.

As there is no reason to assume that our domestic products are the result of crosses only of such wild species as from the start gave exclusively fertile progeny—although, as we shall see, such crosses may indeed have been favoured—it follows that the general inter-racial fertility of domestic products must have been "acquired." Consequently the problem under discussion is not how sterility arose from fertility, but how a form-group in which both inter-racial fertility and sterility occurred, became changed into one, the members of which were all interfertile.

It seems to me that the most simple explanation is offered by the assumption that man from the beginning, for example, from the initial cross or crosses among his animals or plants taken from Nature, in an attempt to domesticate them, has selected the most fertile forms and has continued to do so; in other words, that he has persistently exterminated those forms which were intersterile and kept only those which were interfertile.

While at the present moment intersterility of domestic races might offer considerable advantages, allowing, for example, the cultivation side by side of different varieties of flowers without fear of crossing, there was no such advantage at the very beginning of domestication, when the only object was not to obtain a particular kind but any kind of domestic animal or plant. By this continued selection of interfertile forms, man himself has by now cut off the possibility of obtaining intersterile races.

The following case may illustrate my meaning:

According to my view, our domestic races of fowl, which "without impropriety may, on account of

their enormous differences, be compared to natural species," have arisen from a cross in which more than one wild species has taken part. Prof. Ghigi, the well-known ornithologist of Bologna, is of the same opinion, and Dr. Bateson also evidently looks favourably on this view, as he states that he finds it difficult to believe that all races of poultry should have descended from *Gallus bankiva* only. While all races of domestic poultry are, so far as is known, fertile *inter se*, crosses of *Gallus bankiva* and *G. Somnerati*, or of the former and *G. varians*, give rise, as is well known, to a partly fertile and partly sterile progeny, so that, if our domestic fowl have really arisen from crosses of these wild species, their inter-racial fertility was not primitive, but "acquired" by elimination of the sterile stock.

Thus, according to the views here stated, the starting-point in the formation of domestic races as well as of natural species was the same, to wit, a cross. In those cases in which the product of such a cross was a sterile hybrid, the attempt to originate new races or species was smothered in its birth. Such crosses as gave perfectly interfertile progeny were most acceptable to man, and the cause of the fact that only a very small percentage of the wild species in existence has taken part in the formation of our domestic products may very well be man's partiality for such *ab initio* fertile crosses.

In those cases in which intersterile and interfertile forms arose from a first cross, man selected the interfertile forms, and so obtained the same kind of starting-point for his further efforts as when the first cross had been perfectly fertile from the beginning.

The obtaining of well-defined races from such an interfertile crowd could be attained in one way only, namely, by isolation, and we know that isolation is the alpha and omega of successful breeding.

"Species"-formation in Nature also started from a cross, and Nature's only means of obtaining well-defined form-groups, for example species, also consisted in isolation. Ready-made isolation was presented to Nature by the intersterile forms arisen from a cross; hence these were favoured, and this accounts for the great percentage of intersterile species in Nature.

To summarise: The starting-point in the formation of races by man and in the formation of species by Nature is the same, namely, a mixed stock of interfertile and intersterile forms arising from a cross.

Man selected the interfertile, Nature the intersterile forms, hence the difference in mutual fertility between domestic races and natural species.

Sterility between species, according to this view, therefore, did not arise from fertility but is the direct result of crossing.

J. P. LOTSY.

Velp, November 28.

### Occult Phenomena and After-images.

If the hand be held against a dark background in a very subdued light, coming from behind the observer and falling on the hand, a diffuse glow will be observed round thumb and fingers, frequently uniting the finger tips. A little patience and a moderately clean hand are all that is required to observe the phenomenon.

Further, however, if a hand be cut out of white cardboard (which is easily done by placing the hand, with thumb and fingers moderately spread, on the cardboard, tracing the outline in pencil, and cutting round with scissors) and feebly illuminated in the way described, a similar but somewhat stronger glow will be observed. In the case of both the flesh and the cardboard the shape of the glow can be modified by slow movement of the hand.

Such radiations are frequently described by writers on the occult sciences as being emitted by the human body. For example, in the chapter on magnetism in M. de Dubor's recently published "Mysteries of Hypnosis," I read of a doctor who was making magnetic passes over a lady. "The subject was wearing a black dress, and the doctor had his back to the light. Suddenly, in the semi-darkness which surrounded him, he observed a greyish vapour, like the fumes of a cigarette, issuing from the tips of his fingers, and, with especial clearness, from the index and the middle fingers. Moreover, the index fingers of the two hands seemed to be united by a luminous arc or semicircle. . . . Other persons, on the doctor's invitation, drew near and observed the same phenomenon. . . . Then the room was darkened. . . . In the darkness, twelve of the witnesses perceived nothing at all, and the remaining six perceived only very little."

M. de Dubor and the whole occult school explain the glow, or aura, seen round the hand as being due to magnetic emanations from the body (using the word magnetic in a superphysical sense). They appear to think that the phenomenon is more rare than it actually is, and do not treat the case of cardboard hands. For the phenomenon as observed with these, there would seem to be two possible alternative explanations. One is, that the cardboard is occult cardboard, and the scissors hypermagnetic scissors, and that I have unwittingly impregnated everything with induced ectoplasmic activity. The other is that the phenomenon is a retinal (and rational) one, which can be observed whenever a white, or whitish, surface is seen in a feeble light, the visual purple from the actual retinal image diffusing into the neighbouring parts of the retina. Accepting, for argument's sake, the latter explanation (which accounts at once for the fact that nothing is seen in the dark), the effect will be intensified by the restless movement of the eye, which undoubtedly takes place when objects are viewed in unfavourable circumstances.<sup>1</sup> The eye shifts the image into an unfatigued part of the retina, and the after image persists as a feeble glow. Such phenomena have been frequently described by Dr. Edridge-Green in a variety of forms, and I do not claim any particular originality for this prosaic explanation.

But a further very interesting phenomenon can be observed with the cardboard hand, which has not, I believe, been described. If it be looked at fixedly, the ends of the fingers will be seen to vanish intermittently, now one, now the other, while the extended thumb and little finger appear to move up and down, producing somewhat the appearance of a hand opening and shutting. The effect is very striking, and is pleasantly diversified by the complete disappearance of the hand at intervals. This is due either to retinal fatigue, combined with eye movement, or else to the ferro-forticatory magnetism of the scissors, permeated as they must be with psychic influences and what not. I must leave it to the readers of NATURE to repeat the experiments, and judge for themselves.

Seeing that the festive season (I understand that this is the correct way to refer to Christmas) is upon us, I venture to describe a third occult phenomenon, somewhat analogous to that quoted by Dr. Edridge-Green in NATURE of December 9, p. 772. Two heads, facing one another, are cut out of white cardboard in profile, and observed in a very subdued light against a black background as before. (My heads are about two and a half inches in diameter, and the noses about half an inch apart.) By a delicate manipulation of the scissors one of the heads may be given a feminine character, largely by providing it with

back hair. On careful observation the heads will be seen to approach and kiss repeatedly, separating with rapturous amaze after each contact. Like the other phenomena, including M. de Dubor's magnetic fluid, this cannot be observed in the dark, nor, I may add, even heard, in the case of the cardboard heads.

All the phenomena seem to be observed even more easily by myopic people than by myself. A morning's experiment has convinced me that with suitable illumination and white cardboard a very creditable *séance* can be arranged, including auras, movements and levitations, magnetic emanations, and ectoplasm. This method involves no expense and no hymn singing. Even an atmosphere of reverence is not necessary for the production of the phenomena, although, I admit, the morning of my essay in the occult art was a Sunday morning, which may have had some favourable effect.

E. N. DA C. ANDRADE,  
Artillery College, Woolwich,  
December 11.

### A Relativity Paradox.

It is with great diffidence that I enter the relativity controversy, since I know little or nothing of the subject. Ignorance, however, is seldom a bar to the expression of opinions. I understand that the fundamental idea underlying the theory of relativity is that no signal can be transmitted through

space at a greater speed than the velocity of light. There appears to me, however, to be a method by which, in theory, it might be done, and since we have trains running past embankments with half the speed of light, and shells with observers inside travelling at even higher velocities, perhaps my observer at A (Fig. 1) may be allowed to have two immensely long triangles made of any suitable material; A signals to B by sliding the two triangles together, one over the other, in the direction of the arrows; the point X, where the two sides intersect, moves towards the observer B, who receives the signal when he observes the point of intersection pass over him. If the angle at X is  $10^\circ$  and the triangles are moved together at a speed of ten miles a second (an absurdly small speed for a relativist), the signal will be transmitted to B with more than twice the speed of light.

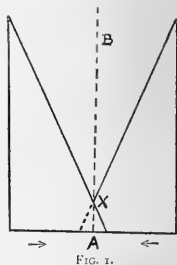

FIG. 1.

Is not "C. C." assuming that when A shifts his triangles by tugging at their bases the apices instantaneously start to move? But the impulse would travel from base to apex at a speed far less than that of light, namely, the speed of elastic waves in the material. After the lapse of sufficient time the two triangles would move uniformly and as a whole; and the mechanism provides a good illustration of a recognisable point moving much faster than light. The relativist does not object to this, since the motion of X does not then correspond to anything coming within the definition of a signal. The time of signalling from A to B must be reckoned from the moment that A gives the impulse to the mechanism.

A. S. EDDINGTON.

Observatory, Cambridge.

<sup>1</sup> See, e.g., Edridge-Green's "Physiology of Vision." (G. Bell and Sons.)

### The Track of a Flat Solid falling through Water.

By using a small crystal of silver nitrate as the "flat solid" and acidulating the water with HCl the track becomes visible, as seen in the reproduction (Fig. 1).

It was by no means easy to "catch" the effect, and I have to thank two members of the Chemical Society of this College, G. R. Ellis and C. P. Sayles, for all the patience and care taken in obtaining so successful a result.

E. W. WETHERELL.

Liverpool College, Liverpool.

### Water Snails and Liver Flukes.

DR. MONICA TAYLOR states in NATURE of November 25, p. 701, that further inquiry is desirable in respect to the intermediate hosts of the fluke, as in some districts where water snails are rare or altogether absent, yet in these districts sheep are subject to liver-rot disease. May I add another point? In the Swansea valley, county of Glamorgan, farmers state very definitely, as the result of years of experience, that liming the land increases the liver fluke, for sheep can be run on the rough pastures in the area with slight loss from liver-rot disease, before it is limed; but after it has been so treated the loss from liver-rot disease becomes heavy, sometimes serious. Theories regarding this are many and varied, but the fact remains that the loss from liver-rot in any given area of land is definitely increased after liming. Does liming a wet sour pasture make it more congenial to the water snail? R. HEDGER WALLACE.

November 28, 1922.

### The Cause of Anticyclones.

THE steady and persistently high barometric pressure that has prevailed over southern England during most of the autumn naturally causes the desire to know how an anticyclone is produced and maintained in such a situation, but the explanations current in meteorological literature are not for the most part efficacious. It is commonly stated that the high pressure is due to a mass of cold and therefore heavy air above it, but for Europe at least this is in direct opposition to observational results, which show that some three-quarters of the whole mass of air over an anticyclonic area is unduly warm. It is the mass of air over the area that is important; its temperature is quite immaterial, and the real difficulty is to explain why the excess of air does not roll off.

A lecturer demonstrating the gaseous laws must provide himself with a closed vessel in which to confine his gas, and if by any means he spills a pound of mercury on his table he will not expect to find it there in a convenient heap the next day or the next week. The meteorologist, on the other hand, having provided his "polar" air does not proceed to explain why it remains *in situ* and does not rather follow the ordinary law of a fluid finding its own level. The difficulty should be faced and not ignored. Doubtless the equivalent of the lecturer's closed vessel is the geostrophic wind surrounding the anticyclone, but one would like to know how the wind is produced and why and how it is maintained.

W. H. DINES.

Benson, Wallingford, December 1.

### German Book Prices.

THERE has been much comment recently in England and America on the above subject: see particularly an article by Prof. Noyes (*J. Ind. Eng. Chem.*, 1922, 99), and editorial comments in the same journal, 1922, 475.

The following prices are examples:

	Beilstein, bound.			Stelzner, unbound.		
	Vol. 1.	Vol. 2.	Vol. 3.	Vol. 1.	Vol. 2.	Vol. 3.
England, shillings.	40	38	102	110	24	38
Germany, marks.	110	110	280	330	70	104
						325

The prices charged to members of the German Chemical Society seem so peculiar that I recently wrote to the society pointing out that much dissatisfaction had been expressed at this state of affairs, and received an answer, from which, as it is too long to insert in full, the following curious passages have been extracted: "... Reckoned on the number of pages the prices are much smaller than those of the publications of almost all foreign chemical societies. *The justice of our fixed prices was confirmed a few days ago from Switzerland.* [The italics are mine.] There can be no thought of making foreign and German prices equal so long as we Germans are compelled to spend unnumbered thousands of our depreciated marks to obtain English books..."

It is amusing to note the proud reference to the bulk of the journal, which enhances its value so much in German eyes. The diffuseness of their publications is considered in most countries to be a disadvantage; recent complaints were about the quality, not quantity. As to the remark about Germans having to spend many marks to purchase foreign books, the obvious comment is that they need not have printed such a lot of paper money.

Was there not an article in the Treaty of Versailles by which Germany undertook not to impose on British subjects any other or any higher direct or indirect fees, dues, or tax, than are imposed on German citizens?

In the circumstances, I am sure most chemists will agree that until treaties with Germany are something more than scraps of paper, money expended in subscriptions to the German Chemical Society is not much better spent than in buying paper marks.

It is to be hoped that the English and American Chemical Societies will soon be in a position to publish a Dictionary of Organic Chemistry at a fixed reasonable price and in a reasonably terse language.

K. C. BROWNING.

16 Bridge Avenue Mansions,  
Hammersmith, W.6, December 1.

### Medical Education.

IN NATURE for December 9, p. 769, Sir Archdall Reid asks the following question: "But can any one tell us of what utility, practical or intellectual, is the biology which medical students learn—facts about the classification of plants, the vascular system of the sea urchin, the digestive system of the leech, the bones in the cod's head, and so on?"

I am not quite clear whether this question has been propounded to invite answers, or to introduce another of Sir Archdall Reid's favourite discussions on mutations and fluctuations, etc. There is, however, scarcely any need to answer the question. So far as I am aware, the biology offered to medical students *to-day* is very different from that suggested by Sir Archdall Reid in the lines from his letter quoted above.

W. J. DAKIN.

Zoology Department, University of Liverpool,  
December 11.



FIG. 1.

SIR ARCHDALL REID in his letter to *NATURE* of December 9, p. 769, tells us that medical students in their biology course learn "facts about . . . the vascular system of the sea-urchin, the digestive system of the leech, the bones in the cod's head, and so on."

Now at this university we have nearly finished the three months' course of zoology for medical students held under Prof. Graham Kerr, and not one of our medical students could answer a question on the subjects named by Sir Archdall Reid. It is a pity, as they are interesting subjects, but there is no room for them in a zoology course for medical students. There is none too much time for the students to learn what they really are taught, namely those parts of zoology which will be, or should be, directly useful to them either as anatomists or medical men.

The point which seems clear is that in the first part of his letter Sir Archdall Reid is asking us for information about "facts" which are not facts, as King Charles II. is said to have done with the Royal Society. What then is the value of his comments based upon these "facts"? J. S. DUNKERLY.

The University, Glasgow.

I HAVE no desire to enter into a discussion with Sir Archdall Reid of the value of the "biology of their own" which medical men "are in a position to construct, and for all practical purposes have already constructed," but it is necessary to point out that his description of the "biology which medical students learn" is not correct. He describes the latter biology as consisting of facts about the classification of plants, the vascular system of the sea-urchin, the digestive system of the leech, the bones in the cod's head, and so on.

Whatever may have been the case when Sir Archdall Reid was a medical student at Edinburgh, not one of the animal types he mentions is now included in the syllabus of elementary practical zoology of the medical curriculum in that university, nor are they included, so far as I know, in the corresponding syllabus in any English university. It is surprising that a member of the medical profession, which is not yet emancipated entirely from the empiricism of earlier times, should write so contemptuously of the leech, once so closely associated with that profession. J. T. CUNNINGHAM.

East London College, Mile End Road, E.,

December 13.

#### Scientific and Industrial Pioneers.

THROUGHOUT the past year it has been my privilege to contribute week by week to these columns a Calendar of Industrial Pioneers. This now comes to an end. This Calendar and the Calendar of Scientific Pioneers, which appeared last year, contain some 930 names, and the lists are believed to be thoroughly representative of that great and ever-increasing army of workers by whom the secrets of Nature are unravelled and natural riches are made available for the benefit of mankind. In selecting the names to be included this year I was assisted by Dr. W. C. Unwin, Professors Eccles, H. C. H. Carpenter and Abell, Mr. F. S. Marvin, and others, and to them I am indebted for suggestions of which I have been glad to make use. EDGAR C. SMITH.

5 Cotehele Terrace, Devonport.

#### W. H. Hudson Memorial.

At a meeting of friends and admirers of W. H. Hudson, held at Messrs. Dent's on November 28, it was agreed that a fitting memorial in stone should be placed in or near one of the sanctuaries in the London

parks which should be dedicated to his memory, subject to the consent of H.M. Office of Works.

It was also decided that Prof. Rothenstein's portrait in oils of Hudson should be presented to the National Portrait Gallery subject to the permission of the trustees, and that all monies over and above those spent upon these works should be devoted to the preservation of wild bird life. An executive committee was appointed to carry these proposals into effect.

Hudson's works are imperishable, but we need a national memorial to the great Englishman whose Nature writings are inspired by that change of heart towards wild life which is replacing the old indifference and spirit of destruction. There were two sides to his genius, that of the man of letters and that of the naturalist. Both these elements are, we feel, properly represented in the suggestions outlined, and we earnestly appeal to the public to make it possible for them to be finely executed. Donations should be sent to the hon. treasurer, Mr. Hugh R. Dent, Aldine House, Bedford Street, W.C.2.

K. B. CUNNINGHAME GRAHAM.

#### Human Blood Relationships and Sterility.

IT is not, I think, generally known that the late Alphonse Milne-Edwards made curious and interesting investigations and suggestions with regard to these matters, but did not live to publish them. A record will be found in Sir Ray Lankester's "Secrets of Earth and Sea" (p. 141). Briefly, his view was that the serums of separated species are toxic to one another—as in the tables given by von Dungen and Hirschfeld and in this country by Back and Edwards, and thus prevent the fertilisation of the ovum of one species by the spermatozoon of another. "He proposed to inject one species by 'serums' extracted from the other, in such a way as seemed most likely to bring the chemical state of their reproductive elements into harmony, that is to say, into a condition in which they should not be actively antagonistic, but admit of fusion and union" (E. R. L.). I would suggest that the perplexing sterility of many normal, healthy young married couples is closely linked up with this question, and it may be that a great future is in store for the surgeon who would boldly adopt the suggestion of Milne-Edwards with the view of harmonising the serums of married persons whose relative sterility would appear to be capable of tabulation after the manner of the hæmolytic charts given by Back and Edwards and by the writer of the article in *NATURE* of December 2. CHRISTOPHER BLAYRE.

So far as I know, the blood groups dealt with in the article on "Human Blood Relationships" in *NATURE* of December 2 concern only the agglutination (and sometimes lysis) of red corpuscles and not any other of the obscure differences which determine incompatibility between species and subspecies. These no doubt include the qualities of tissues other than blood, and the project to alter them by transferring blood or serum from one species or individual to another seems very unlikely to succeed: the blood is only one tissue among many and its qualities certainly do not dominate those of the body as a whole. In the course of working out the inheritance of the agglutination groups a great deal of germane information has been obtained, but there is no indication that one combination of groups in parents is more likely to be sterile than another. The failure of many normal healthy young married couples to produce children is probably capable of a much simpler explanation.

THE WRITER OF THE ARTICLE.



Emission of Cathode and X-rays by Celestial Bodies.<sup>1</sup>

By Dr. HENRI DESLANDRES.

THE emission by the stars of X- and cathode rays and similar radiations has already been considered and investigated by various writers.<sup>2</sup> The two kinds of radiation, however—X- and cathodic—are not separable, for each, when it meets an obstacle, gives rise to the other; this interdependence having been clearly pointed out by de Broglie. But their properties are different: X-rays move in straight lines, and are much the more penetrating, while cathode rays are easily deflected into helical paths by a magnetic field—or, again, by an electric field. The paths of the electrified particles forming cathode rays, under the influence of a magnetic field like that of the earth, have been revealed by the detailed calculations of Störmer: they are very interesting, and much more varied than the trajectories due to gravitation.

I. In several notes, from 1896 to 1922,<sup>3</sup> I have suggested the emission of cathode and X-rays by the sun, and also by the nuclei of nebulae. The rays of the solar corona can thus be explained, and also the aurora borealis and the magnetic disturbances of the earth, their connexion with sunspots, and even the lag of these disturbances behind the passage of a spot across the central meridian of the sun's disc—a lag due to the deviation imposed by the outer solar magnetic field. The same idea was put forward also in 1896 by Birkeland, who carried the investigation further: he was able to reproduce, in the laboratory, some of the phenomena of the aurora borealis by means of a small sphere placed in a vacuum, magnetised like the earth, and bombarded by cathode rays. Later, the researches, both theoretical and experimental, of Störmer made a great advance in the investigation, and placed almost completely beyond doubt the emission by the sun of ordinary cathode rays. In terms of these rays, Störmer explains the smallest details of the aurora borealis, so rich in singular phenomena. He has even been able to locate the origin of the rays in the sun, and to determine the value of the external solar magnetic field. This value, which is very small and equal to  $10^{-7}$  gauss, is exactly that which I found in 1911 by another method depending on the radial velocities of the solar prominences recorded at Meudon.

The earth also emits these special radiations. The radio-active bodies in its solid crust and in its atmosphere emit  $\alpha$ -,  $\beta$ -, and  $\gamma$ -rays, which ionise the atmospheric gases and explain partly the permanence of the terrestrial electric field. To explain the whole field, it must be assumed that there enter, from the outside, rays which are very penetrating—even more penetrating than any known X-rays. Further, if one ascends in the atmosphere—as did Kohlhörster, who reached a height of 9000 metres—the number of ions formed per

second in a closed chamber is found to increase rapidly; at 9000 metres it is eight times as great as at the surface of the earth. The amount of this penetrating radiation therefore increases rapidly with altitude. It proceeds probably from the sun, directly or indirectly, or even from cosmic space,<sup>4</sup> but its exact origin has yet to be determined.

Such are the first results; they are extremely interesting, but still very incomplete. The investigation thus begun should be pursued with every means at our disposal.

II. Researches connected with the atmospheres of yellow stars, carried on at Meudon during 1922 with Burson, have led me to conclude that in these stars there is an extremely penetrating X-radiation, emitted by the interior strata or the nuclei of the stars. These results, which have been stated very briefly in former communications,<sup>5</sup> are now given in detail.

The sun, which is a yellow dwarf star, shows, as is known, in its integrated spectrum,<sup>6</sup> three groups of calcium lines— $H_1$ ,  $K_1$ ;  $H_2$ ,  $K_2$ ;  $H_3$ ,  $K_3$ —weak, but very distinct—which represent, respectively, the lower, middle, and upper strata of its gaseous atmosphere or chromosphere. Burson and I have discovered these lines—in particular, the lines  $H_2$ ,  $K_2$ ,  $H_3$ ,  $K_3$  in several giant stars which are equally yellow. They have the peculiarity that the lines, when compared with the neighbouring continuous spectrum, are stronger and wider than in the spectrum of the sun. The middle and upper strata of the chromosphere are more luminous and important than the corresponding solar strata.

Stars of the two types, giant and dwarf, have at the surface, however, the same chemical composition, the same temperature, and the same surface brightness. How is the difference in the luminosities of their atmospheres to be explained?

The atmospheric strata are represented by the radiations H and K, which, as is now known with certainty, are emitted by the ionised atom of calcium. If, therefore, we consider, in each type of star, a tube normal to the surface, having unit cross-section and extending from the surface to the outer limits of the atmosphere, the brightness of each stratum in the tube will be proportional, or at least closely related, to the number of ions formed in it per second. The number of ions formed must therefore be greater in the giant stars. Now one of the principal causes of ionisation already pointed out is the intense emission of electrons by the

<sup>1</sup> The earth also probably emits a very penetrating X-radiation—more penetrating than the  $\gamma$ -rays of radium: this has been suggested by some writers. But, if it exists, it is relatively weak, and it has not yet been clearly separated from the very penetrating X-radiation coming from external sources.

<sup>2</sup> Sur la reconnaissance dans les étoiles de couches successives de leur atmosphère et des variations périodiques de ces couches (*Comptes rendus*, 171, p. 451, 1920, by Deslandres). Recherches sur l'atmosphère des étoiles, Reconnaissance d'étoiles qui ont les mêmes brillantes de l'atmosphère que le soleil (*Comptes rendus*, 172, p. 405, 1921); Recherches sur l'atmosphère des étoiles, Reconnaissance de la couche supérieure dans quelques étoiles et comparaison avec le soleil (*Comptes rendus*, 173, p. 479, 1921); Recherches sur l'atmosphère des étoiles, Propriétés des étoiles qui ont les mêmes radiations et les mêmes couches de la chromosphère que le soleil (*Comptes rendus*, 175, p. 122, 1922, by Deslandres and Burson).

<sup>3</sup> Burson and I intend to publish shortly some new results. In particular, we have discovered that, in certain giant stars, the lines  $H_2$ ,  $K_2$  of the upper stratum are displaced towards the red, and the lines  $H_3$ ,  $K_3$  of the middle stratum are displaced towards the violet, as in the case of the sun.

<sup>4</sup> The integrated spectrum is that which the sun would give if it were as far from us as the stars.

<sup>1</sup> Translation of a paper read before the Paris Academy of Sciences on October 2, 1922.

<sup>2</sup> X-rays are constituted like the  $\gamma$ -rays of radium, except that the latter have a greater frequency. The ultra X-rays, discussed in this note, have a still greater frequency. In the same way,  $\beta$ -rays resemble cathode rays. As for  $\alpha$ - (positive or anode) rays, which play an important part in ionisation in general, they are absorbed very quickly, and move only a short distance from their origin.

<sup>3</sup> *Comptes rendus*, 126, p. 1323, 1898; 134, pp. 1134 and 1486, 1902; 150, p. 65, 1910; 152, p. 1453, 1911; 155, p. 1573, 1912; 157, p. 517, 1913; 171, p. 451, 1920; 172, pp. 405 and 709, 1921; 175, p. 122, 1922. See also <sup>4</sup> Observations de l'Eclipse totale de 1893 (Gauthier-Villars, 1899).

surface, produced, in the yellow stars, at a temperature of about  $6000^{\circ}\text{C}$ .; but the ionisation from this cause is the same in the two types of star. In order to explain the greater brightness of the giant stars, it is necessary to suppose that they contain another source of ionisation which is peculiar to them, or more important than it is in the dwarf stars. The principal supplementary cause appears to me to be a penetrating radiation emitted by the interior layers of the star; this radiation would be stronger in giant stars, which have greater masses, and therefore higher internal temperatures. In an example cited by Eddington<sup>7</sup> the temperature at the centre reaches  $4,650,000^{\circ}\text{C}$ ., the mass being only one and a half times that of the sun. The wavelength of maximum energy for a black body at this temperature is  $6\text{ \AA}$ .—corresponding to an X-ray near the ultra-violet, and not very penetrating; but, according to the theory, the radiation extends much further towards the very short wave-lengths, the penetration of which is much greater; and the intensity of these extreme radiations increases with the temperature of the star. The emission of exceptionally penetrating radiations by giant stars is therefore admissible. Further, in the case of giant stars which are in the phase of increasing temperature, the atoms are dissociated, and their breaking-up is accompanied by an intense emission of  $\alpha$ -,  $\beta$ -, and  $\gamma$ -rays. It should be remarked that recently certain rays of radium have been observed, much more penetrating than any previously known, the source of which must be in the very nucleus of the atom.

In the yellow stars, all these radiations, of very high frequency and of great penetrating power, form, in reality, only a very small part of the total radiation; but their remarkable electrical properties assign to them an important rôle in the electrical phenomena of stellar atmospheres. It is not, however, intended to assert that the existence of the radiations is proved, but it is very probable. As a matter of fact, we have a very imperfect knowledge of the properties of the material in the interior of a star near the surface and in the atmosphere; and, as often happens in astronomy, the deductions rest on wide extrapolations. In forming conclusions, great care must be exercised.

There has been a great deal of discussion on the nature of the solar surface. In my opinion, setting aside every theory and every explanation, the solar surface is a simple fact of experience; it is a surface of discontinuity, with a clear-cut boundary, such that the light emitted by the interior is much more intense than that given by the exterior. I give the name "atmosphere" to all that is outside this surface. The word "surface," however, should not be understood strictly in its geometrical sense: it implies, actually, a relatively thin luminous stratum which, at our distance from it, appears to have no thickness. The solar surface has often been described as a cloud, made up of incandescent liquid or solid particles. If this were so, in all the yellow stars having the same temperature, whether giant or dwarf, the pressure of the gases at the surface should be the same; but it has been objected that we have no knowledge of any matter which remains liquid at a temperature of  $6000^{\circ}\text{C}$ . The attractive optical theory of Schmidt also

has been advocated: when thoroughly examined, however, it is found not to be applicable to the sun. Let us say simply that, from a cause still imperfectly understood, solar matter, probably gaseous, acquires suddenly, in a stratum called the *surface*, the emissive power of a solid body, and there are good reasons for believing that the pressure of the gas in this stratum varies little from one yellow star to another, so long as the temperature of the strata is the same.<sup>8</sup> These considerations support the idea of the very penetrating emission postulated in the giant stars.

III. These special rays, remarkable for their penetration and their electrical action, have been known or suspected only for a few years; but their importance is already declaring itself, and I think that they will furnish the key to several of the still numerous enigmas presented by the celestial bodies.

The matter of the sun, then, probably emits X-, ultra-X-, and corpuscular rays, with an intensity which increases from the surface to the centre. In the spots, which are in general cavities, the emission is strongest in the centre, and, because of its greater penetration, is able to persist in spite of local absorption and the diminution of the ordinary light. Similarly, if the earth gives rise to a radiation of this kind, its intensity should be greater at the poles than at the equator.

These radiations should be borne in mind especially in considering the nebulae—in particular, the gaseous and planetary nebulae. A nebula with a stellar nucleus may be considered as a star the atmosphere of which is extraordinarily developed and contains special gases, such as nebulum. The conditions are then, on a very large scale, those of the yellow giant stars examined above, the atmospheres of which are particularly bright; and the same causes may be held to account for the luminosity in the nebulous atmosphere. Moreover, the nucleus, being of the Wolf-Rayet type, is one of the hottest stars: it is conceivable that the maximum emission takes place, for the nucleus in the X-region, and for the nebula, properly so called, in the visible region. The luminosity is produced by radiations of very short wave-length, but with a habitual tendency towards longer wave-lengths. Lastly, the nucleus may contain a large proportion of radio-active bodies. These ideas were put forward in 1902, and Russell has recently developed similar hypotheses.<sup>9</sup>

If a nebula has no nucleus, we may suppose that there are radio-active bodies disseminated in the space which it occupies. Similarly, in the lower part of our atmosphere, a considerable fraction of the ions formed per second is due to the gaseous emanations of radium and rhodium spread abroad in the air. If there were a greater proportion of radio-active bodies, the gas might become luminous.

To sum up, the penetrating radiations are interesting in the highest degree, and it is important that we

<sup>7</sup> If the pressure at the surface is less in the giant stars, the average density of which is smaller, we can explain partly the stronger ionisation in these stars by the very interesting theory of M. N. Saha. This theory deals with effects due to temperature alone, and the point of view is different. In a giant star the pressure gradient is evidently less steep, but the average pressure in the middle stratum, and especially in the upper stratum, may be very nearly the same as in a dwarf star. It should be noted that the greater proportion of the positive ions of calcium in the upper atmosphere may also be explained simply by the repulsion due to the positive charge on the star.

<sup>8</sup> Deslandres, *Comptes rendus*, 134, pp. 1134 and 1486, 1902; Russell, *Proceedings of the U.S. National Academy of Sciences*, 5, No. 10, p. 470.

<sup>9</sup> *Astrophysical Journal*, 48, pp. 205-214, 1918.

should study, immediately and as thoroughly as possible, those which are within our reach and are disclosed by Köhlhörster's experiment. The ionisation of gases in a sealed vessel has been measured in our atmosphere up to an altitude of 9000 metres; but it is necessary to repeat the experiment at several places on the earth, and to extend it up to the greatest altitudes reached in exploring balloons. The undertaking, it is true, will be costly; it involves especially on the

countries which have the greatest resources. I proposed, at the International Astronomical Congress, which met at Rome in May last, that there should be international co-operation for the complete study of the electrical phenomena of our atmosphere at great altitudes. The determination of the exact origin of these penetrating radiations is one of the most important problems confronting physical astronomy at the present time.

### The Desensitising of Silver Bromide-Gelatin Plates.

By DR. T. SLATER PRICE.

IT is well known that the more sensitive a photographic plate is, the greater the care that has to be taken with respect to the actinic value of the light used in the dark room during the operation of development. The less the amount of light used, the more difficult it becomes to control the result; and it is therefore not to be wondered at that attempts have been made to modify the course of procedure in such a way that the exposed plate could be developed in a fairly good light. During the last few years various so-called "desensitisers" have been put on the market; when the exposed plate is either treated with a solution of these before development, or when some of the desensitiser is added to the developer, the plate can safely be developed in a light which would otherwise give rise to very bad fogging.

At the recent Deuxième Congrès de la Chimie Industrielle, M. A. Seyewetz gave an interesting account of the subject, and his paper has been published in *Chimie et Industrie*, 1922, 8, 308-311.

A. and L. Lumière and Seyewetz, in 1907, were the first to notice that a silver bromide-gelatin plate becomes less sensitive when bathed in a solution of a developer such as diaminophenol, quinol, or pyrogallol. The loss in sensitivity varied slightly in different regions of the spectrum, but was most marked in the yellow and green. At a much later date, in 1920, Lüppo-Cramer noticed that the desensitising action was much increased when sulphite was omitted from the developing solution, that is, when the developer was used in such a condition that it readily oxidised in the air. After immersion for a minute in a 0.05 per cent. solution of the developer the plate could be developed in yellow light without fogging. Such a method of desensitisation was insufficient, however, for orthochromatic and panchromatic plates, and moreover, the solutions underwent rapid alteration in the absence of sulphite.

Desensitisation only became a practical proposition when Lüppo-Cramer, in 1921, discovered the pronounced desensitising action of the azine dye, Phenosafranine, and also of other dyes belonging to the same class, on ordinary and panchromatic plates. Contrary to what one would at first suppose to be the case, these dyes do not owe their action to functioning as colour screens; solutions of Phenosafranine transmit red and violet light, and yet they desensitise plates for these regions of the spectrum. Also, the violet safranines desensitise just as do the red safranines, although their absorption spectra are very different. These facts are very similar to those observed with sensitisers, and

Lüppo-Cramer has shown that certain optical sensitisers for one haloid salt of silver may act as desensitisers for other salts. For example, Erythrosin, Rhodamine B, Pinachrome, and Pinacyanol, which are the best sensitisers for chloride and bromide of silver, when used in very dilute solutions (1:20000) diminish the sensitivity of silver iodide-gelatin plates from 6 to 16 times; Phenosafranine gives a reduction in sensitivity of about 40 times.

Lumière and Seyewetz have made investigations to see if there is any relation between the desensitising power of a substance and its chemical constitution. They have found, with the safranines, that the presence of the characteristic phenazine grouping,

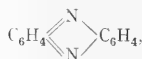

is insufficient in itself, and that amino-groups substituted in the benzene nuclei must also be present. Thus Neutral Red, which is a Eurhoidine having the formula

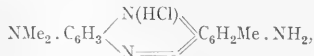

has desensitising properties approximating to those of Phenosafranine, which is

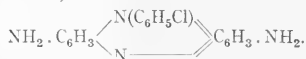

Safranines in which one of the amino-groups has been eliminated, as in aposafranine, or in which this group is replaced by oxygen, as in the safranones, are notably less active as desensitisers. If both of the amino-groups are replaced by O or OH, as in safranol, there is no longer any desensitising action. The acetylation of the amino-group, or its diazotisation and copulation with a phenol, destroys the desensitising properties of the safranine, while the replacement by ethyl of the phenyl group attached to the nitrogen has no effect. The Indulines, which are near cousins to the safranines, as also the thiazines and the oxazines, do not act as desensitisers. On the other hand, other colouring matters which have very different constitutions from that of safranine as, for example, picric acid, Indian Yellow, Chrysoidine, etc., are weak desensitisers; Aurantia (1:1000) desensitises as actively as safranine for the blue rays, but is noticeably less active towards other parts of the spectrum.

It follows from the above that there does not seem

to be a definite relation between the constitution of the dye and its desensitising properties. The conditions are thus very similar to those which hold in the case of sensitizers.

The great drawback to the use of Phenosafranine is its pronounced staining properties; it can only be removed from the gelatin film by prolonged washing. König has recently put on the market a desensitizer, Pinakryptol, which is claimed to be as active as Phenosafranine, but which neither stains gelatin, celluloid, nor the skin, although it gives a deep green solution.

A satisfactory explanation of the desensitising action

of these substances is still wanting. Lüppo-Cramer claims that the phenomenon is connected with the formation of an oxidation product of the dye. Lumière and Seyewetz have shown, however, that if an unexposed plate is bathed in a solution of Phenosafranine it recovers its original sensitivity after being washed sufficiently long to remove the colouring matter. It is probable, according to Lumière and Seyewetz, that any oxidation product of the dye would be adsorbed by the silver bromide and not be removed by washing, so that the recovery in sensitivity would not be explicable on Lüppo-Cramer's theory.

### Obituary.

PROF. GEORGES LEMOINE.

**M.** GEORGES LEMOINE, professor of chemistry at the Polytechnic School, Paris, whose death at the age of eighty-one has just been announced, was born at Tonnerre in 1841. He entered the Polytechnic School in 1858, and two years later became *Elève ingénieur* at the École des Ponts-et-Chaussées. He early devoted himself to the study of chemistry, and investigated the compounds of sulphur and phosphorus, one of which, the sesquisulphide of phosphorus, is now largely employed in the igniting composition of the lucifer match in place of ordinary phosphorus. The substitution of this compound for phosphorus—now compulsory in most countries where matches are made—has been attended with the most beneficial results in the industry, the "phossy jaw" of the match-worker, or necrosis of the facial bones, being practically a thing of the past.

Lemoine also studied the reciprocal transformation of the two best-known allotropes of phosphorus. By heating known weights of phosphorus in closed flasks at 440°, the temperature of boiling sulphur, for varying lengths of time, and separating the products by carbon disulphide, he was able to determine the influence of time and pressure on the direction and extent of the change. He showed that the extent of the transformation is determined by the tension of the vapour, as in the case of other phenomena of volatilisation and dissociation. *In vacuo*, the conversion of ordinary into red phosphorus becomes more and more rapid as the temperature is raised. The rapidity of the transformation varies with the amount of phosphorus used. At any given moment the rapidity depends not only upon the quantity of ordinary phosphorus remaining, but also upon the quantity of red phosphorus already formed. The phenomenon is pre-eminently one of vapour tension and depends upon the capacity of the vessel in which the transformation—which is never complete—is effected. These facts are now well known and are uniformly acted upon in the phosphorus industry.

Questions of chemical dynamics had always a certain measure of attraction for Lemoine, and although he was not a particularly prolific contributor to chemical literature, much of his published work is concerned with their investigation. One of the most important of these inquiries relates to the conditions of chemical equilibrium of hydriodic acid. This substance was chosen as suitable for the study of the general phenomena of chemical equilibrium for the reason that the

constituent elements are monatomic; they combine, or dissociate, without change of volume (at the temperature of the experiment), and the thermal effects of combination are very slight. The aim of the investigation was to show that under given conditions of temperature and pressure, a mixture of the two constituent gases in given proportions will attain sooner or later a definite state of chemical equilibrium in which only a certain proportion of the hydriodic acid possible is actually formed, varying with the temperature, pressure, and proportions of the gases present, but always the same for the same conditions. The conditions studied were heat, pressure, mass, the action of porous bodies, of oxygen and of light. The main results have long since been incorporated into the general theory of chemical change, and call for no detailed account. At the time of their publication they constituted a notable and novel contribution to chemical dynamics.

It has long been known that mixed solutions of ferric chloride and oxalic acid are decomposed by light with the evolution of carbonic acid (Marchand, Jodin), and that the rate of decomposition depends on the intensity of the light. Lemoine studied this change with a view of determining how far it may be made the basis of an actinometric method. He found that for a given intensity, the evolution of gas is at first uniform, but that when about half the total quantity of carbon dioxide has been evolved, the rate of decomposition gradually diminishes. The greater the volume of the liquid, the longer is the time before decomposition slackens. When the two solutions are separately exposed to light for several hours and then mixed, decomposition takes place more rapidly than if the solutions had not been previously insulated. Dilution with water increases the change, due probably to hydrolysis of the ferric chloride. At ordinary temperatures the mixed solutions are practically unaffected in the dark. On heating, gas begins to be evolved at 50° and increases rapidly in amount as the temperature rises. The general course of the change is, however, very similar to the influence exercised by light and is affected apparently by the same conditions.

Lemoine occasionally worked at subjects of organic chemistry, such as the nature of the paraffin hydrocarbons and the dissociation of haloid compounds of olefines under the influence of heat and pressure, but organic chemistry had evidently few attractions for him, and his work in this special field was very limited and calls for no special comment.

Lemoine, having served the Polytechnic School, in various capacities, from 1871, was elected professor in 1897. He succeeded Friedel as a member of the chemistry section of the Academy of Sciences in 1899.

T. E. THORPE.

HOWARD FOX.

MR. HOWARD FOX, of Falmouth, died on November 15, in his eighty-sixth year. In the intervals of a busy commercial and consular career—the firm to which he belonged were appointed American Consuls by George Washington—he contributed very largely to our knowledge of the natural history of his native county, Cornwall, especially in the domain of geology. The record of his work is to be found in many papers published by the Royal Geological Society of Cornwall, of which he was president during the years 1893 and 1894, the Geological Society of London, the *Geological Magazine*, and other scientific institutions and journals. We can only refer to a few of his more important discoveries.

Mr. Fox traced the distribution of the Radiolarian (Coddan Hill) Beds of the Lower Culm Series throughout the west of England; and, in collaboration with the late Dr. G. J. Hinde, studied the characters of these rocks and of their radiolaria. He also discovered the radiolarian cherts of Mullion Island, which belong to a much lower geological horizon. Among other fossils found by him is the notable *Pterocoon miris*, probably allied to the pteropods, occurring in the supposed Lower Devonian rocks of Bedruthan Steps, north of Newquay, the younger stages of which are sometimes preserved in such a way as closely to resemble graptolites. He also published accounts of other Cornish fossils, relying on the help of specialists for their determination and description.

But Mr. Fox's interest was by no means confined to the fossiliferous rocks. He studied the igneous and metamorphic rocks of the Lizard peninsula and made himself familiar with every nook and corner of that rock-bound coast. By mapping a small portion of the sloping face of a cliff, on a scale much larger than that of any published map, he proved conclusively that the serpentine and hornblende-schist had been intimately interfolded; and, by observations on another portion of the coast, established the fact that certain rocks, apparently belonging to the "Granulitic Series," were intrusive in the surrounding schists. He also made the important discovery that the Man of War rocks, off Lizard Head, are mainly formed of a corrugated igneous gneiss, quite different from any rock occurring on the mainland.

In petrology and mineralogy, as in palæontology, Mr. Fox availed himself of the help of specialists, and all those who were thus brought into personal contact with him were captivated by his geniality and stimulated by his enthusiasm.

LORD SUDELEY, F.R.S.

CHARLES DOUGLAS RICHARD HANBURY-TRACY, fourth Baron Sudeley, whose death on December 9, in his eighty-third year, will be regretted in many circles, was elected a fellow of the Royal Society in

1888, in recognition of his services to science as chairman of the British Commission to the Electrical Exhibition at Vienna in 1883. Of late years, Lord Sudeley persistently advocated in the House of Lords and in the Press the increased use of our museums and picture-galleries for the education and recreation (in the highest sense) of the public. In 1910, struck by the value of a demonstrator engaged by the Science Committee at the Japano-British Exhibition, he urged that similar guide-lecturers should be attached to our national museums. The Natural History Museum was the first to adopt the suggestion, and now, thanks to Lord Sudeley's untiring efforts, all the larger public museums have one or more of these popular adjuncts. Next he actively promoted the production and sale of picture postcards by Government museums. Lastly, as shown by his article in the *Nineteenth Century* for October, he was preparing to move for the appointment of a Royal Commission to consider the better working of the museums of this country.

MR. HERBERT WOODVILLE MILLER, who died on December 4, was one of the pioneers of electric lighting in this country. In 1886 he was appointed to assist Crompton and Co. in working out the system of electric light distribution in the West End of London which they had successfully installed in Vienna. By 1899 it was evident that stations centrally situated in populous districts were unsuitable to meet a growing demand, and Miller therefore designed and carried out the power station at Wood-lane which supplies the Kensington and Knightsbridge Company and the Notting Hill Co. He was engineer and manager of the Kensington Co.; the station beneath the Albert Hall is an excellent example of an accumulator station. He served on several committees of the International Electrotechnical Commission, and his thorough knowledge of electrotechnical subjects made him a most useful member of the editing committee of the British Engineering Standards Association.

THE *Chemiker Zeitung* of November 23 announces the death on November 20 of Prof. August Horstmann, at the age of eighty. Prof. Horstmann was the first to show the applicability of the laws of thermodynamics to chemical problems, his first paper on this subject being published in the *Berichte* in 1869. His other work was mainly in this direction, and was concerned with problems of dissociation, the determination of vapour densities and vapour pressures, specific heats, and heats of reaction. He was therefore the pioneer in a branch of physical chemistry which has since been developed particularly by Van't Hoff and Nernst. For some years Horstmann was professor emeritus of theoretical chemistry in the University of Heidelberg.

We learn from *Science* with much regret of the death, on November 1, of Dr. R. W. Willson, emeritus professor of astronomy at Harvard University, at the age of sixty-nine years.

## Current Topics and Events.

BROADCASTING has now been carried on for some time at the Trafford Park works of the Metropolitan-Vickers Electrical Co., Ltd., on behalf of the British Broadcasting Company, and on December 15, representatives of the Press were invited to inspect the equipment of the station and to listen to a short, typical broadcasting programme. The present arrangements are of a somewhat temporary nature, made with the view of gaining experience, and it is expected in course of time to improve both the technique of transmission and reception, and the quality of the programmes. In a short address, Mr. A. P. M. Fleming expressed his view that wireless telephony has an important future as an educational and social feature of daily life, and he hoped that the public would not take the present transmissions as the best the Broadcasting Company expected to be able to give them. Research is being carried on actively to improve the faithfulness of reproduction of music and speech. It has been found necessary to select carefully the kind of voice which is best suited to the vagaries of the microphone, and it was foreshadowed that a special wireless studio technique will have to be developed, for which special training of the performers will be required. There is no doubt that the transmission of some items leaves much to be desired, but if a microphone or a substitute for it could be developed, having no prejudice for any particular sound, a considerable improvement would be effected. The simplest sounds, such as in solo pieces, give the best results, and it would seem that when a number of voices or instruments are operating simultaneously, the microphone is not able to deal faithfully with the various sounds.

THE annual exhibition of scientific apparatus organised by the Physical Society of London and the Optical Society will be held on Wednesday and Thursday, January 3 and 4, from 3 to 6 P.M. and from 7 to 10 P.M., at the Imperial College of Science, South Kensington. Mr. W. Gamble will lecture on "Reproduction of Colour by Photographic Processes" at 4 P.M. on January 3 and at 8 P.M. on January 4; Prof. E. G. Coker will lecture on "Recent Photo-Elastic Researches on Engineering Problems" at 8 P.M. on January 3 and at 4 P.M. on January 4. All the lectures will be illustrated by experiments. More than fifty firms are exhibiting apparatus and a number of experimental demonstrations have been arranged. Invitations to attend the exhibition have been given to the Institution of Electrical Engineers, the Institution of Mechanical Engineers, the Chemical Society, the Faraday Society, the Wireless Society of London, and the Röntgen Society. Members of these societies should apply to the secretary of the society to which they belong for admission tickets. Others interested should apply direct to Mr. F. E. Smith, hon. secretary of the Physical Society, Admiralty Research Laboratory, Teddington, Middlesex.

A JOURNEY of more than seven thousand miles from Peking to India was completed early in December when General Sir George Pereira arrived at Calcutta.

The *Times* gives some details of his route. Leaving Peking nearly two years ago, Sir G. Pereira went by rail to Taiyuen. From there he made for Hoyang, crossing the Hoang-ho, and reached Sianfu, the ancient Chinese capital in the Wei valley. The route was thence across the Tsinling mountains to Chengtu, in the Szechwan basin, and up the valley of the Min into the Kansu province. Passing through Siningfu and Tenkar, Sir G. Pereira entered Tibet on a little known route. The track lay at an altitude of about 12,000 ft. through an arid country in which supplies were scanty and the weather conditions somewhat trying. The Yangtze was crossed at Giergundo and eventually Lhasa was reached in October. From Lhasa to Darjeeling a fairly well known route was followed. One of the most interesting facts mentioned in the *Times* article relates to the so-called Amnemachin range in the bend of the Hoang river in north-eastern Tibet. This is a solitary snow-capped mountain and not a range. Its height has not been measured, but Sir G. Pereira suggests that it may prove to be the highest mountain in the world. About half the entire journey was done on foot, and even in the most brigand-infested regions the travellers were never attacked.

THE Munro lectures in anthropology and prehistoric archaeology for 1922 in the University of Edinburgh have been delivered in November and December by Prof. R. A. S. Macalister, of University College, Dublin, on the subject of "Rock Carvings and Inscribed Symbols of the Neolithic and Bronze Ages." Starting with certain Spanish stones presenting linear devices that could be proved to degenerate copies of the human figure and other concrete objects, Prof. Macalister developed the thesis that an explanation of this kind would account for the enigmatical devices, such as concentric rings, found so often in Great Britain and Ireland on exposed rock faces, standing stones, and slabs built into dolmens and chambered cairns. British monuments were brought into relation with similar objects in wider archaeological areas; by the extended use of the comparative method, much light has been thrown on symbols and devices the meanings of which have been the subject of much vague conjecture. The female figure carved in some French neolithic tomb chambers is a goddess of death, and representations of her, which might degenerate till only two eyes or even a single one remained, can be recognised on stones forming part of funereal structures in our own islands. Such structures, as Irish folk-lore bears witness, were visited for superstitious purposes by the living, and the cup marks common on the stones forming them were intended for real or simulated libations offered to the spirits of the place. Such cup marks on exposed rock faces in the open might be explained on the hypothesis that religious sanctuaries of perishable materials had once existed in their vicinity. The same system of interpretation was applied to other marks and devices of a similar kind.

THE application of eugenic principles to the improvement of the human race is discussed by Dr. J. G. Adami in an address before the International Eugenics Congress in New York, published in the *Eugenics Review* for October 1922. Dr. Adami points out that eugenic measures hitherto suggested or adopted have been chiefly negative in character, aiming at preventing a progressive increase in the number of defectives in the population. He advocates an important measure of practical positive eugenic value, which the Eugenics Education Society would do well to consider seriously. Dr. Adami's suggestion arises out of his experience as a member of the scientific committee of the Advisory Council of the Ministry of National Service during the war—a committee which analysed the physical state of the manhood of Britain during the last year of the war, examining the records of nearly two and a half million men. That a high percentage in many industrial areas were found to be physically unfit is well known. The eminent services of American psychologists in applying intelligence tests successfully to American recruits are now also widely recognised. Dr. Adami's suggestion is based upon these two results. It is, that eugenicists organise centres throughout the country where young persons of eighteen could be given voluntary tests of physical fitness and intelligence, the lists of those who attain standard A being published. In this way a true aristocracy of mental and physical fitness would arise which would be of the utmost value to the nation.

IN the second of his Chadwick public lectures on "Relative Values in Public Health," delivered on December 14, Sir Arthur Newsholme referred to the relative weight of mortality of different diseases in relation to their degree of preventibility. He stated that tuberculosis caused ten deaths for every three due to the acute notifiable diseases. Tuberculosis is a too little recognised cause of death in childhood, and its prevention is an essential part of child welfare work, the foundation of all public health work. The amount spent on public health in large English and American towns averages about 5s. *per capita* per annum, or in England, from 4 to 8 per cent. of the total rates collected *per capita*. Sir Arthur Newsholme is of opinion that the greatest and quickest return in health for money expended—outside the ordinary sanitation of a city—is in respect of work on maternity and child welfare, and on the prevention and treatment of tuberculosis and venereal diseases.

A CONFERENCE on Industrial Fuel will be held next spring in Paris under the patronage of M. Le Trocquer, Minister of Public Works, and with the support of the Société d'Encouragement pour l'Industrie Nationale. The proposed agenda include discussions on the assay of various fuels, rules for testing boilers, producers, and furnaces, standard methods of making measurements required in controlling the use of fuel, construction of furnaces, use of pulverised fuel and of low-grade fuels. Any communications concerning the conference should be addressed to the Président de la Commission

d'Utilisation du Combustible, Ministère des Travaux Publics, 246 boulevard Saint-Germain, Paris. Notices and reports concerning the conference will be published in *Chaleur et Industrie*.

ACCORDING to a statement in the *Meteorological Magazine* for November, daily weather charts of the Northern Hemisphere are now being prepared by the Meteorological Office each day. The charts are exhibited in a ground-floor window in the Air Ministry, Kingsway, and show barometric pressure and wind for an area covering roughly the temperate zone from the Pacific coast of America in the west to the western borders of Asia in the east. In an adjoining position, at the Air Ministry, a large black-board map of weather conditions in north-west Europe is shown. These maps giving the existing weather conditions over such a large area of the earth's surface will doubtless aid in the improvement of weather forecasting.

NO. 24 of the Reprint and Circular Series of the National Research Council, Washington, which has been received, is a pamphlet by C. J. West and H. Gilman dealing with "Organomagnesium Compounds in Synthetic Chemistry." It contains a bibliography of 1485 papers, as well as an exhaustive index. Monographs of this type are very useful to investigators, and the National Research Council in America is doing valuable work in arranging for their publication. The Research Information Service of the Council is prepared to supply information about scientific methods and results, and their applications in engineering, industry, and education. No charge is made for replies to inquiries which do not necessitate a special search for information (there are extensive files already assembled); those requests for data which would necessitate the expenditure of a considerable time for accumulation are acknowledged, with an estimate of the cost. The Service has a staff of specialists, and is in touch with current scientific work of all kinds. It is clear that such an organisation must be of very great service to investigators in the United States, and the Scientific and Industrial Research Department in this country might consider the formation of a similar organisation in this country.

THE Mann Juvenile Lectures of the Royal Society of Arts will be delivered on Wednesdays, January 3 and 10, by Mr. C. R. Darling, who will take as his subject "The Spectrum, its Colours, Lines, and Invisible Parts, and some of its Industrial Applications." Admission is by ticket only.

THE Dorset Field Club is offering the Cecil medal and prize of 10*l.* for the best paper on "Recent Advances in Chemistry as applied to Agriculture, with special reference to Dorset Conditions." The competition is open to persons aged between 17 and 35, either born in Dorset, or resident in that county for one year between May 1, 1921 and 1923. Further particulars may be obtained from Mr. H. Pouncey, Midland Bank Chambers, Dorchester.

DR. R. A. HOUSTON, of the University of Glasgow, has in the press, for publication by Messrs. Longmans

and Co., "Light and Colour," a book intended for the general public, and dealing in a popular way with the discovery of the spectrum, the nature of light, the Einstein deflection of light, the quantum, invisible rays, spectroscopy and the constitution of the atom, the primary colours, colour blindness, colour photography, artificial illumination, photochemistry, phototherapy, and the psychology of colour. Another book in the same publishers' announcement list is "Gas Manufacture," by Dr. W. B. Davidson, in which the subjects of gas engineering and gas supply are fully dealt with from the chemical standpoint. The book aims at meeting the demand of the gas engineer for a more intimate acquaintance with the chemistry and physical chemistry of gases than he may already possess, and is intended as a textbook for the young student of gas engineering.

THE first part of Messrs. Wheldon and Wesley's illustrated catalogue of recent purchases of rare

books now offered for sale, which is issued this month, is remarkable for the number of rare and interesting books on herbal and garden literature which it contains. There are also books on early medicine, birds, shells, and other subjects, which are, in many cases, fully illustrated. The transcription of the titles has been very carefully done and the bibliographic details will be of value to lovers of books. The collection contains a first edition of Peregrinus "De Magnete" published in 1558 and also the first English edition of Harvey's account of his discovery of the circulation of the blood, with the title "Anatomical exercises concerning the motion of the heart and blood." In addition, the collection contains first editions of Jenner's accounts of his discovery of vaccination, in regard to which it is said that he was advised not to publish them in the Philosophical Transactions lest they should injure his reputation as author of a paper, already published therein, on the cuckoo.

### Our Astronomical Column.

RELATIVITY AND SPACE.—The *Irish Ecclesiastical Record* of November 22 contains an article on the subject by Rev. H. V. Gill, S.J. It is intended for general readers, and opens with an explanation of the reasons for the introduction of time as a fourth dimension. From this the author goes on to consider the nature of space, and comments on the difficulty of conceiving that a mere vacuum can be modified by adjacent matter, and also how matter could exert its influence over remote matter across a vacuum without involving "action at a distance" which Einstein rejects. He then quotes Einstein's "Side-lights on Relativity," an English translation of two lectures delivered in 1920 and 1921. Many of Einstein's followers in England have been inclined to abandon the conception of the æther, but he himself states "according to the general theory of relativity, space is endowed with physical qualities; in this sense, therefore, there exists an ether . . . space without ether is unthinkable . . . there would be no propagation of light. . . . But it may not be thought of as . . . consisting of parts which may be tracked through time." It is useful to direct attention to this clear statement of Einstein's view, and it would help matters if those who reject the æther conception were to indicate how they surmount the difficulties that are pointed out.

THE MASS AND PROPER MOTION OF 40 ERIDANI.—This interesting triple system was discovered by Sir W. Herschel in 1783. A is of magnitude 4.5, B 9.4, C 10.8. The distance AB is 83' and BC is 3". All three have the great proper motion of 4" per annum in position-angle 213°. Prof. G. Abetti makes a study of the system in vol. 30 of the Proceedings of the *Accademia dei Lincei*. He adopts the parallax 0".219, which makes the absolute magnitudes 6.2, 11.1, 12.5. Using Doolittle's elements, which give a period 180 years to be BC, the masses in terms of the Sun are found to be B=0.20, C=0.12. C is the least massive star yet measured; this position was previously held by the companion of Krüger 60, mass 0.19. B is a very anomalous star, since it appears to be of spectral type A in spite of its small

luminosity; recent photographs at the Lick Observatory indicate that C is of type M<sub>d</sub>, with the H<sub>β</sub> line bright.

The velocity of the system at right angles to the line of sight is 88 km./sec.

It is of interest to compare this system with  $\sigma$  Coronæ, also investigated by Prof. Abetti. The combined mass is here 5.57 times that of the Sun. The evidence as to relative masses is contradictory; he provisionally assigns equal masses, and deduces for the densities 0.34 and 0.99 in terms of the Sun. The spectral types of both are F<sub>9</sub>.

DISTRIBUTION OF STARS OF SAME SPECTRAL CLASS.—The study of the distribution of stars of similar spectra is very important, especially if it leads to some definite law regarding their grouping with regard to the Galaxy. The special case of the B-type stars is discussed in a recent circular (No. 239) of the Harvard College Observatory, by Dr. H. Shapley and Miss A. J. Cannon. It was thought at first that very few B-type stars, fainter than the seventh magnitude, existed, and that these formed quite a local system. The authors find that, while the former does not now hold good, the bright B stars do indicate the existence of a local star cloud. The results of the discussion are plotted in four figures showing the galactic distribution of the stars, the figures being confined to stars brighter than 5.26 magnitude, stars between magnitudes 5.26 and 6.25, between magnitudes 6.26 and 7.25, and finally between magnitudes 7.25 and 8.25. The result of the investigation clearly shows that the fainter the B stars are the more they are situated along the galactic equator. Quite a considerable number of stars are used for each figure, namely 346, 367, 564, and 719. Forming median galactic latitudes for each thirty degrees of longitude the highest values in each figure are  $-15^{\circ}.5$ ,  $-15^{\circ}.0$ ,  $-11^{\circ}.5$ , and  $-3^{\circ}.5$ . More than 90 per cent. of the fainter B stars are within ten degrees of the galactic equator. A table is given showing all known B stars to the apparent magnitude 8.25 which are in higher galactic latitude than  $50^{\circ}$ .



## Research Items.

**MAMMALS AND BIRDS FROM HAITIAN CAVES.**—A small collection of bones of mammals and birds were obtained in 1921 by Mr. J. S. Brown and Mr. W. S. Burbank during geological studies under the U.S. Geological Survey for the Republic of Haiti, from two caves situated between 3 and 4 kilometres N.E. of St. Michel and 600 metres above sea-level. These bones have now been described respectively by Mr. G. S. Miller, junr., and Mr. A. Wetmore (Smithsonian Miscell. Coll. vol. lxxiv. Nos. 3 and 4). Rodents were the more plentiful among the mammals, the most abundant being *Isolobodon portoricensis*, Allen, which also occurs in Porto Rico and the Virgin Islands. Two new genera are established: *Alphatreus*, with *A. montanus*, n.sp., as genotype, which is allied to *Plagiodontia* and *Isolobodon*; and *Ithyodontia*, genotype *I. levir*, n.sp., allied to *Isolobodon*. *Brotomys voratus*, Miller, was also present as well as a ground sloth, doubtfully referred to the genus *Megalococcus*, and a few unidentified mammals, while man was represented by the head of a femur and an implement made of chert. Early man, however, though known to have used these rodents as food, does not appear in this case to have been responsible for the presence of their remains in the caves. Their importation would seem to be due to a huge extinct barn owl, which Mr. Wetmore names *Tyto oxtolca*, n.sp. Possibly the *Chempelia passerina*, *Crotophaga ani*, and *Tolnachus gabbi*, also present in the caves, were further victims of the owl.

**AN INDIAN POND-SNAIL.**—Dr. N. Annandale and Maj. R. B. Seymour Sewell have published (Rec. Ind. Mus. xxiii. pp. 215-292) a memoir on the banded pond-snail of India (*Vivipara bengalensis*). The latter author contributes an account of the anatomy and bionomics; Dr. Annandale deals with the systematic features and with the histology of the edge of the mantle and the external ornamentation of the shell. Spiral rows of horny chæte and fine spiral ridges on the periostracum are present, and, indeed, best developed in the fully formed embryo, and disappear, as a rule, in the full-grown shell. In those shells ornamented with bands of dark pigment, the latter are periostracal in origin and, with the test sculpture, correspond in position with the rows of chæte and the spiral ridges. The free edge of the mantle bears at least three digitiform processes,—other secondary ones may be present,—and the processes correspond in position with and are concerned in moulding the periostracal sculpture, the colour pattern and the sculpture of the test. In the systematic account eleven races of the species are recognised. The parasites and incoleæ met with are recorded and include spirochaetes and ciliates in the alimentary canal, rarely spirocysts and developing cercariae, but frequently encysted cercariae of two species.

**MEADOW GRASSES.**—In an article on the comparative morphology and development of *Poa pratensis*, *Phleum pratense* and *Setaria italica*, in the *Japanese Journal of Botany*, vol. i. No. 2, pp. 53-85 (1922), Makoto Nishimura has devoted special attention to the phenomena attending the germination of these grasses in comparison with *Agrostis alba*. In *Poa pratensis* the percentage of germination was lowest, 50 per cent., and the process extended over the longest time, while in *Setaria* 95 per cent. of the seeds were viable, and started into growth very rapidly. Absorbing hairs were developed on the coleorhiza at an early stage, and continued functioning until long after the elongation of the roots; similar hairs were also produced from the epiblast. The various stages of development during the first two seasons of growth have been followed out, being characteristic in each case. *Setaria* shows the greatest

depth and spread of roots, but the other species exhibit more branching of a larger number of extra nodal roots, thus attaining the same end. Each bud derived from the stool is usually associated with two crown roots, in which case the bud development is normal, but when only one crown root is present the bud fails to grow out. In all three species the inflorescence is a spike, and the embryos are of the usual type. In *Poa pratensis*, however, polyembryony is frequent, and arises in various ways, the various types of abnormality apparently being due to the sting of an insect. A useful bibliography and a series of clear plates add to the value of this communication.

**BRAZILIAN METEOROLOGICAL SERVICE.**—Yearly volumes of meteorological observations at Rio de Janeiro and at numerous stations in Brazil for the three years 1912, 1913, and 1914, under the superintendence of Señor Sampaio Ferraz, have recently been received. Each volume contains about 100 pages of tabular matter. The observations at Rio de Janeiro are similar in detail to those made at European observatories, hourly values being published of rainfall and sunshine, and detailed monthly results of general meteorological phenomena. In many cases the results are compared with the mean results for more than thirty years. The observations for the provinces are on a uniform scale and the monthly and yearly results can be combined or compared with others in different parts of the world. Wind frequency is regularly recorded and also the mean velocity, so that knowledge of surface winds is readily available for aircraft; the results are in every way a valuable addition to the world's meteorology. Each volume contains tables and maps showing the rainfall for the first six months and second six months of the year, and for the year as a whole, at stations covering Brazil, the various falls being shown in the maps by degrees of shading. Generally the two halves of the year have very different rainfalls. In each of the three years the total rainfall reached 118 inches at one or more stations; in 1914 there were four stations with a rainfall exceeding 118 in., the maximum being 3596 mm., or 142 in., at Remate de Males, Amazonas; this place had the heaviest rainfall in two of the three years. The total annual rainfall at Rio de Janeiro ranged from 36 to 38 inches in the three years.

**HEAT CONDUCTIVITIES OF METALS UNDER PRESSURE.**—Volume 15 of Contributions from the Jefferson and the Cruft Laboratories of Harvard University is dedicated to Prof. E. H. Hall, who for more than forty years has been a member of the Harvard faculty. The volume is a reprint of 31 papers by the staff and students which have appeared in scientific and technical journals and proceedings of societies during 1921 and 1922. Eight of these papers are by Prof. Duane and his pupils and deal with various properties of X-rays. Six are by Prof. Bridgman, and one of these deals with high-pressure experiments. The heat conductivities of eleven metals have been measured up to pressures of about 12,000 atmospheres by the bar or by the cylinder method. The rate of change with increase of pressure is fairly uniform for each metal, the total change for the maximum pressure being an increase for lead of 21 per cent., tin 15 per cent., zinc 2.5 per cent., and a decrease for iron of 0.3 per cent., copper 9 per cent., silver 4 per cent., nickel 1.4 per cent., platinum 2 per cent., bismuth 38 per cent., and antimony 25 per cent. Between these results and those obtained previously by Lussana there are serious differences. The ratio of the thermal to the electrical conductivity is considerably changed by pressure, a result not in accord with the electron theory of conduction.

## Photosynthesis.

GR<sup>E</sup>AT interest was taken in the joint discussion on photosynthesis between the sections of Chemistry and Botany during the British Association meeting at Hull. The discussion was presided over by Prof. H. H. Dixon, who was supported by Principal J. C. Irvine.

The discussion was opened by Dr. F. F. Blackman with a paper entitled "The biochemical problems of chloroplastic photosynthesis." Dr. Blackman said that as the next two speakers were to take up the special aspects of photochemistry and energetics he would restrict his remarks to certain other aspects. He would deal with the active system of photosynthesis and its organisation in the living cell and bring together the evidence which supported the thesis that here we have to do, not with a simple photochemical reaction, but with a complex system in which other components, that might be described provisionally as protoplasmic components, play an essential part.

The first point developed was that there are numerous lower plants which obtain all their carbon by the reduction of  $\text{CO}_2$  in the dark without the intervention of radiation, and synthesise all their organic compounds from this source. Here there is utilised the chemical energy of the oxidation of nitrogen, sulphur, or their compounds. In these chemosynthetic organisms there is not a gain of energy, but only an exchange of oxidation potential; the gain to the organism is substance for growth. It may be asked whether this power is entirely absent in the higher plants and what connexion the chemical machinery of it has with the chemistry of photoreduction of  $\text{CO}_2$ .

The second point was the fact, now thoroughly investigated, that the seedlings of many plants at a stage when they have developed chlorophyll to a full green colour may be quite incapable of reducing  $\text{CO}_2$  in light, and give out as much  $\text{CO}_2$  from respiration in light as in darkness. Some other component or property lags behind the chlorophyll in its development, and the slow, steady rate of its development is the same in darkness or light.

A third point of interest is the efficiency of photosynthesis in the golden-leaved varieties of certain shrubs. Here the amount of chlorophyll may be as low as 4 per cent. of the normal green form and yet under medium conditions the reduction of  $\text{CO}_2$  may be as great as in green leaves. The fact has been established that the golden leaf needs more light than the green to carry out the same rate of reduction of  $\text{CO}_2$ . It looks as if with these extreme variations of chlorophyll what counted was the cube root of the amount of chlorophyll present—a single dimension of the colloid micellæ and not the total mass—which may be taken as an indication of the organisation of the system.

A fourth point considered was the relation of photosynthesis to temperature. It is established that for a high rate of photosynthesis it is not sufficient to have intense radiation and concentrated  $\text{CO}_2$ , but a high temperature is also essential. For each temperature there is a specific maximum of activity which cannot be exceeded unless the temperature is raised. The specific maximal values increase rapidly for rising temperature, having a temperature coefficient of about 2 for a rise of  $10^\circ \text{C}$ . This temperature relation is quite different from that of a pure photochemical reaction, and it provides a further indication that we have to deal with a complex system in which dark reactions may play a controlling part.

The fifth point to be raised had to do with the organisation of the active system. Warburg in investigating the action of the narcotic phenylurethane upon the rate of photosynthesis finds that the process undergoes great depression of rate with perfect recovery on removal of the narcotic. The relation of the depression to the external concentration of the drug gives a typical adsorption isotherm, indicating that the narcotic acts by adsorption on a surface from which it displaces temporarily some reactant substance of the active photosynthetic system.

Taking all these pieces of evidence together, Dr. Blackman considered that we are forced to conclude that the chloroplast contains an active system of several components related together in a complex organisation.

Prof. E. C. C. Baly then presented the results of experimental work on photosynthesis carried out at Liverpool. The conversion of a substance A into substance B might, he said, be represented as the sum of the three equations:

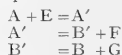

where E, F, and G are quantities of energy and A' and B' represent the reactive forms of A and B. The reaction is exo- or endo-thermic according as  $F + G - E$  is positive or negative. In any case a quantity of energy, E, must be supplied in order to start the reaction, and this may be done by means of (1) heat, (2) light, or (3) a material catalyst. Now the energy can only be supplied in "quanta," and if E is large, only the use of radiation of short wave-length makes the number of "quanta" to be introduced sufficiently small to be practicable. For the conversion of a molecule of carbonic acid into formaldehyde and oxygen 150,000 calories are necessary, and this can be supplied in a single quantum by radiation at wave-length  $200\mu$ . Carbonic acid has an absorption band at this frequency and formaldehyde ought therefore to be produced when a solution of  $\text{CO}_2$  in water is exposed to ultra-violet light. This has now been shown to take place.

In order to bring about the reaction by means of visible light it is necessary to have present a coloured substance with basic properties, and Malachite Green has been found to fulfil the conditions. There seems little doubt that the formation of formaldehyde in the leaf takes the following course:

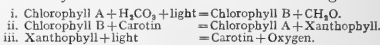

The photosynthesised formaldehyde is extraordinarily reactive and is best represented by the formula  $\text{CHOH}$ . It is polymerised rapidly to a mixture of carbohydrates, in which are found hexoses (20 per cent.), cellulose, and cane-sugar. In the presence of nitrite it is converted into form-hydroxamic acid and hence into amino-acids and a mixture of cyclic bases in which pyrrole, pyrrolidine, pyridine, conine and glyoxaline have been detected. The active (energised) forms of the aminoacids are the immediate source of proteins.

Mr. G. E. Briggs described some experiments to determine the relation between the radiant energy absorbed and the carbon dioxide assimilated by the green leaf (*Phaseolus vulgaris*) in different parts of the visible spectrum. For three different parts of the spectrum the carbon dioxide assimilated was measured, and the energy absorbed by chlorophyll a

and chlorophyll *b* was estimated from data obtained, due allowance being made for the energy diffusely reflected by the leaf. The results were of the following order: for the yellow-red (570-640 $\mu$ ), 15 calories per c.c. of carbon dioxide, for the green (510-560 $\mu$ ), 7, and for the blue (430-510 $\mu$ ), 22+, these being maximal values.

Mr. Briggs pointed out that since the heat of formation of the most probable products of assimilation ranges from five to six and more calories per c.c. of carbon dioxide, the indications are that both chlorophyll *a* and chlorophyll *b* take part in the photochemical reaction. Referring to Prof. Baly's suggestions as to the part played by the different pigments in the photosynthetic process, he said that since the quantity of each pigment underwent relatively little change during prolonged assimilation no energy was supplied from this source, and, further, that since as much oxygen was evolved as carbon dioxide absorbed in the red and the green parts of the spectrum—regions where no energy is absorbed by the xanthophyll—as well as in the blue, it was not necessary to postulate a photochemical reaction involving xanthophyll in order that oxygen might be liberated.

Prof. I. M. Heilbron and Mr. C. Hollins put forward some speculations on photosynthesis. The large number of plant products in which the predominant carbon nucleus is  $C_5$  or a multiple of this suggests that this unit has a special significance. The photosynthesised reactive hexose may be supposed, in addition to its further condensation to sugars, cellulose, glucosides, etc., to furnish by dehydration  $\omega$ -hydroxymethylfurfural. This by oxidation and decarboxylation can give a stabilised  $C_5$  compound, which, either as the furan derivative or (by opening

of the ring) as dihydroxyglutaconic dialdehyde, may be a source of pentoses and of condensation products of these. Simple schemes were suggested showing how two, or three, molecules of a "pentose" can give rise by ordinary condensation reactions to anthocyanins ( $C_{15}$ ), terpenes ( $C_5$ ,  $C_{10}$ ,  $C_{15}$ , etc.), coniferyl alcohol ( $C_9$ ), and the numerous related compounds, coniine ( $C_8$ ) and the phenopyrrolecarboxylic acids ( $C_8$ , etc.). The degradation of hexose into "pentose" represents the respiration of the plant. Against the suggestion of Robinson (British Assoc., 1921) that anthocyanins result from the condensation of two hexose and one triose molecule are to be set the absence of nonoses in Nature and the failure of all attempts to obtain benzene derivatives from hexoses.

Papers were also contributed by Dr. F. C. Eve and Prof. M. C. Potter.

Prof. R. Robinson thought that the accumulation of active formaldehyde and formhydroxamic acid scarcely accounted for the almost inexhaustible variety of plant products. The alkaloids were probably produced from hexoses rather than built up atom by atom from formaldehyde. He was unable to accept the suggestions of Prof. Heilbron and Mr. Hollins as to the significance of the  $C_5$  unit. The anthocyanins he preferred to consider as  $C_6 + C_3 + C_6$  rather than  $C_5 + C_5 + C_5$ . Although nonoses had not been found in Nature, E. Fischer had obtained a nonose which was fermentable.

Dr. E. F. Armstrong emphasised the importance of cane-sugar in the carbohydrate metabolism of green leaves.

Prof. Baly briefly replied to some of the points which had been raised, and the discussion was then closed by a few remarks from the chairman, Prof. Dixon.

### Progress in Engineering.

THE James Forrest lecture delivered in 1903 by Dr. W. H. Maw dealt with some unsolved problems of engineering; his presidential address, read before the Institution of Civil Engineers on November 7, directs attention to the progress which has been made towards the solution of certain of these problems. In ordinary researches the conclusions arrived at often remain untested for more or less long periods, and when they are tested it is not unusual for such tests to develop facts which, if known earlier, would have decidedly affected the character of the research carried out. During the war, especially in aeronautical researches, immediate results were wanted, and reasonable suggestions arising from research were, as a rule, tested without delay. As a result conclusions were arrived at and advances made much more promptly than would have been possible under other conditions.

For many years past there has been steady growth in the demands for larger structures and machines. In the case of bridges there are three ways in which increases of span may be made commercially attainable: First, by improvements in the structural designs; second, by the reduction of the so-called factors of safety now adopted; third, by the use of improved structural materials and constructive details. Dr. Maw does not think that there is much chance of obtaining material aid by the first of these methods; it does not appear likely that any new type of design will be evolved possessing striking advantages as compared with those already known and investigated. The prospects from the second method are better; there are two classes of allowances, namely, (a) stresses due to wind pressures, changes of temperature, and so on, which depend upon local circumstances

and other matters of individual judgment, so that a reduction cannot be calculated upon, and (b) allowances which depend upon the quality of all the materials used and the soundness of the workmanship. The allowances under the latter head might be materially reduced as compared with those considered necessary even ten years ago. During that period, vast improvements have been made in our steel manufacturing processes, especially in the direction of ensuring uniformity of quality, while the facilities for thorough testing and inspection have been enormously increased.

In reference to the third way, there are no indications that we have reached the limits of progress in the use of improved structural materials. In long span bridges, the importance of the "specific tenacity" of the material (*i.e.* the ultimate strength in tons per sq. inch divided by the weight in pounds of one cubic inch) is exceedingly great, since the weight of the structure itself forms the larger portion of the total load supported. The successful manufacture, on a commercial scale, during recent years, of various high-quality alloy steels has quite changed the aspect of affairs and has materially enlarged the limits of the practically permissible spans of different types of bridges. At present, the most hopeful line of progress appears to lie in still further improvements in alloy steels and their treatment. Research work bearing on this subject is being vigorously prosecuted by our leading steel makers and affords every ground for expecting substantial advances.

Improvements in metallic alloys have been rendered possible by the revelations of microscopical research. Prior to the development of this type of analysis,

we knew that steel subjected to a certain heat treatment had its mechanical qualities altered. Microscopic investigation, aided by improvements in the preparation and treatment of the samples to be examined, has enabled us now to trace out, step by step, the changes which take place at various stages of the treatment, as well as the effect—in the case of alloys—of modifications in the proportions of the constituents. Microscopic research also promises to be of value in providing definite information as to the changes of structure in different metals when injured by fatigue, or are just on the point of fracture, and Sir Robert Hadfield has made some valuable experiments in this direction.

During the last few years a most important addition has been made to our methods of discovering defects in materials or workmanship by the application of the X-rays. Great progress has been made, and there is every promise of further developments in the early future. At present steel or iron can be searched to depths of about 3 inches, aluminium and its alloys to about 6 inches, and timbers of various kinds from about 15 to 20 inches.

Researches on the thermal efficiency of the steam engine during the last few years have related chiefly to the development of the steam turbine. Prior to 1903 the best economical result obtained with a steam turbine was that of a 1500-kilowatt alternator built by Messrs. Parson in 1902; this machine had a steam consumption corresponding to about 13.5 lb. per indicated horse-power per hour. A test carried out in 1918 on a 10,000-kilowatt unit by the same makers gave a consumption of 7.75 lb. per horse-power per hour—a reduction of about 43 per cent. on the 1902 performance. The corresponding thermal efficiency is nearly 27.7 per cent. Bearing in mind certain points in the design of this turbine and making allowance for them, it appears that a thermal efficiency of 30 per cent. for a steam motor is within our reach.

Mechanical gearing in turbines has proved in a number of cases to be unsatisfactory. The question of how to prevent the defects which have occurred forms probably the most important problem which has demanded the attention of mechanical engineers for many years past. The failures have been variously

attributed to the use of unsuitable metal for the gears, to irregularity in the gear cutting, to disturbance in the alignment of the shafts and to other causes. The whole subject deserves more systematic and thorough investigation than it has received hitherto.

The development of the steam turbine has been the result of an enormous amount of strenuous and original work, both theoretical and constructional. On the theoretical side, the determination of the laws controlling the discharge of steam through orifices of various shapes is yet very far from being complete, and there are many other problems, such as the critical speeds of shafts, the best number of stages to be adopted under different conditions, and so on. On the constructional side may be mentioned the selection of suitable materials for the blades and the mode of fixing the latter, devices for preventing steam leakage, securing efficient lubrication, and methods of governing and of obtaining the high vacua so essential for securing economic performance.

The pistons of reciprocating engines have speeds ranging from 600 to 800 feet per minute. In steam turbines the blades are being run successfully at 600 feet per second. A small turbine (150 horse-power), made recently by Messrs. Ljungström of Stockholm, runs at 40,000 revolutions per minute and has a blade speed of 952 feet per second—more than 11 miles per minute.

In conclusion, Dr. Maw directed attention to one fact which appeared to him of far greater importance than all the others: in none of the researches referred to, varied and extensive as they have been, is there the slightest trace of finality. Much as has been discovered and great as has been the progress made, it is most certain that we have at present effected only the preliminary opening up of the mine of knowledge and that the real wealth of its contents is as yet unknown to us. We can only say that the "impossible" of yesterday has become the "possible" of to-day, and in the early future many of these possibilities bid fair to become accomplished facts. Surely this is a great inheritance, which should invite our coming generations of engineers to make most strenuous efforts to secure greater—and still greater—developments, so that they may in their turn leave behind them a heritage more glorious still.

## Radio-Telephony and Broadcasting.<sup>1</sup>

By A. P. M. FLEMING, C.B.E.

IN considering the development of radio-telephony, it is frequently overlooked that the earliest methods of communication, such as by sound and light, do not involve the use of wires; the negative and non-descriptive term "wireless" has, therefore, been displaced by the term "radio." Radio waves are electro-magnetic in character, being pulsations in the æther of space, and they differ among themselves and from radiant heat, light, and X-rays, only in their amplitude and wave-length. Some waves change and diminish gradually in amplitude, and are said to be "damped"; others maintain their amplitude and are "continuous." Radio waves exist and are used which vary in wave-length from a few yards to ten or twelve miles; they are the longest electro-magnetic waves.

Given the means whereby electrical waves can be produced and detected, it is comparatively simple to arrange to send signals by the morse code, and this is done every day in ordinary radio-telegraphy.

Radio-telephony is in some respects analogous to ordinary telephony. The ordinary telephone circuit of microphone transmitter, line, and receiver contains a battery which sends a continuous current round the circuit and through the telephone receiver. If speech is made in the microphone, the vibration of the microphone diaphragm varies the pressure on carbon grains in the microphone. This varies the resistance in the battery circuit, and the current, instead of flowing steadily, rises and falls according to the sound waves impinging on the transmitter diaphragm. The fluctuating current varies the pull on the diaphragm in the telephone receiver, and this sets up sound waves similar in character to those originally spoken into the transmitter. In radio-telephony there is a generator capable of producing very high-frequency oscillating current which can be radiated from an aerial, just as heat and light are radiated from a fire or lamp. This radiated oscillation is known as a "carrier wave." Near the generator is a modulator receiving the speech and modifying the amplitude of the high-frequency oscillation, and imparting changes in the carrier waves in

<sup>1</sup> Substance of a lecture delivered at a meeting of the North-east Coast Institution of Engineers and Shipbuilders, Newcastle-on-Tyne, on Friday, December 15.

accordance with the speech vibrations, which result in a fluctuating current radiated to the receiver.

At the receiving end the oscillating current is changed into a uni-directional current, and made suitable for reception for hearing in an ordinary telephone receiver. It is an essential condition of reception that the receiving set be "tuned" to respond to the wave-length of the station it is desired to hear. Electrical waves emanating from a transmitter travel in all directions through space, and can be picked up by any number of receivers, provided these are tuned to receive the particular wave-length used.

Broadcasting stations comprise transmitting-room, studio, green-room, offices, listening-in room, and workshop. Programmes are designed to operate throughout the whole evening, and all tastes and ages are catered for. It is usual for artistes to operate at the station, but by means of ordinary telephone transmission it is possible to transmit a political speech or entertainment from a central hall in a city to the broadcasting studio, and to radiate it from the station to listeners.

The pioneer work in broadcasting as a means of public entertainment and instruction was undertaken by the Westinghouse Co. of Pittsburgh, U.S.A., in December 1920. The Metropolitan-Vickers Co. of Great Britain has close technical association with this company and has the advantage of this pioneer experience. There are now more than 500 broadcasting stations in the United States, and their growth without proper co-ordination has caused some confusion.

To avoid this confusion in Great Britain, the Government insisted that manufacturers of radio apparatus should co-operate in forming a Broadcasting Company to control broadcasting. Three stations of the eight contemplated are in operation, London, Manchester, and Birmingham, and it is intended that Newcastle shall have a station. The revenue of the Broadcasting Company for maintaining stations is provided by the manufacturers, but the Government assists by remitting a proportion of the licence fee.

Care should be taken in selecting a set suitable to the local conditions. A good crystal set costing about four or five pounds will receive satisfactorily over ten or fifteen miles. A two-valve set would pick up over fifty or one hundred miles, and in addition to this, a further two-valve amplifier could be arranged to increase the distance to 300 miles, or would permit the use of a loud speaker up to fifty miles. Sets sold by reputable manufacturers are very efficient and simple to operate.

The development of radio-telephony will have a very profound influence upon social life. It will overcome the isolation of the rural worker, the invalid, and those who are confined indoors, and it has unique potentialities for entertainment, instruction, and the development of public taste.

### Excavations at Borg en Nadur, Malta.

AT a meeting of the Royal Anthropological Institute held on November 21, Prof. F. G. Parsons, vice-president, in the chair, Miss Murray gave an account of some excavations carried out by her at Borg en Nadur, Malta, during the past summer. The excavation was purposely limited to a small area to the west of the so-called "dolmen" of Borg en Nadur in a terraced field which had been made over this site, as high as the cap-stone of the dolmen, and completely covering the remains of the ancient buildings. The principal building found was an apsidal structure of the type peculiar to Malta. From the small size of the stones and the primitive

style of the building, Miss Murray is of the opinion that Borg en Nadur is considerably older than Mnaidra and Tarxien. The principal results of the excavation are (1) the discovery of types of pottery transitional between the neolithic and bronze age; (2) the finding of painted pottery showing Cretan influence, perhaps of the Middle Minoan era, thus connecting prehistoric Malta with another ancient civilisation.

In the discussion which followed the reading of the paper, Prof. J. L. Myres said the pottery of Malta presents a puzzling problem. Evidence is needed as to which of the large number of types are contemporary. The pottery from the "window tombs" of the lower levels of the ravines with flat alluvial bottoms, which form the characteristic watercourses of Malta, presents certain affinities with the "Sikel" pottery of Sicily. Miss Murray distinguished between "neolithic" and "bronze age" pottery; but, whereas she found the latter at ground level in the apsidal building, at Hal Tarxien the lower occupation layer, resting on ground level, contained no metal, and the bronze age interment had been found over a sterile layer of some thickness imposed upon the neolithic stratum and at a considerable height up the great stones of the temple. The painted pottery, for which a Cretan affinity had been suggested, is of the type found in Sicily and Southern Italy for which Prof. Peet had traced a Thessalian rather than an Ægean relationship. Prof. Myres also expressed his opinion that the Borg en Nadur building was of late and degenerate type rather than early and primitive. Mr. H. J. E. Peake said that Miss Murray's suggestion of a type of pottery transitional between the neolithic and bronze age types was new and needed substantiation. The restricted distribution of the "bronze age" type suggested that it might be an intrusion, of which Miss Murray's transitional type was an attempted copy.

### University and Educational Intelligence.

BIRMINGHAM.—Dr. Dorothy Margaret Patrick has been appointed assistant lecturer in physiology, Grade III.

Mr. T. V. Barker, of the department of mineralogy at Oxford, has been invited to deliver a course of lectures, during the spring term, on chemical crystallography.

The annual meeting of the Court of Governors will be held on Thursday, February 8.

The vice-chancellor (Sir Gilbert Barling, Bart.) is to represent the University at the celebration of the 500th anniversary of the foundation of St. Bartholomew's Hospital in June next.

The new hall of residence for men students is to be known in future as Chancellor's Hall.

GLASGOW.—The University has received a gift of 25,000*l.* from Mr. Henry Mechan, of Mechans, Limited, engineers and contractors, Glasgow, for the foundation of a new chair of public health.

LONDON.—At a meeting of the Senate on December 13, a resolution was adopted accepting a bequest of 3000*l.* made by the late Sir William Meyer, fellow of University College and High Commissioner for India, to be applied at the discretion of the Senate "with special reference to the encouragement of proficiency in European History, and in the History and Geography of India." An offer from the council of the Society of Antiquaries to continue the Franks studentship in archaeology, of the value of 100*l.* per annum, for a further period of five years was accepted with thanks.

A grant of 15*l.* from the publication fund of the University has been made to the hon. editor for zoology of the *Annals of Applied Biology* in aid of the publication in that journal of the M.Sc. thesis entitled "The Life-History and Bionomics of the Turnip-Gall Weevil," by Mr. P. V. Isaac.

The degree of D.Lit. has been conferred on the Rev. G. H. Dix, an internal student, of King's College, for a thesis entitled "'The Angel of Jahweh': A Study in the Origin and Development of a Religious Folk-Legend, with special reference to the Messianic Expectation of the Hebrew Race."

THE general meeting of the Association of Women Science Teachers will be held at University College, Gower Street, on Saturday, January 6, 1923. The programme includes an address by the retiring president and a lecture on relativity by Dr. Dorothy Wrinch. The hon. secretary of the association is Miss E. M. Ridley, 10 Gresley Road, N. 19.

THE annual meeting of the Geographical Association will be held in Birkbeck College, London, E.C.4, on Thursday and Friday, January 4 and 5, 1923, Sir John Russell will deliver his presidential address on the subject of "The Influence of Geographical Factors in the Agricultural Activities of a Population" on the opening day of the meeting. Among lectures to be given during the meeting are: "Types and Materials of Houses in England," Mr. H. Batsford; "The Place of Geography in the Education of the Adolescent," Dr. Olive Wheeler; "Geography and Business Life," Prof. W. S. Tower; "The Coming Industrialisation of China," Prof. P. M. Roxby.

THE second annual general meeting of the Association of Heads of Departments in Pure and Applied Science was held on Saturday, December 9, at the Woolwich Polytechnic. The members were welcomed by the chairman of the Governors, Mr. C. H. Grinling, who delivered an address upon the desirability of "association" in all branches of society, whether trade or professional, commercial or political. He emphasised the importance of a new association taking a long view of the range of their activities and of developing into a body of national, or better still, of international, rather than of merely parochial importance. The meeting decided later to extend the activities of the association by the admission of members from the provinces. Mr. C. E. Larard, of the Northampton Polytechnic, was elected as chairman, and Dr. W. A. Scoble and Mr. R. T. Smith, of Woolwich Polytechnic, as joint secretaries for the ensuing year.

THE report for 1921-22 by Dr. Cranage on the Cambridge University Local Lectures shows that the revival which took place in 1919-21 has been maintained as regards the number of courses (62, of which 15 were on scientific subjects), but that the average attendance per lecture dropped from 142 in 1920-21 to 127, and per class from 38 to 33. The Summer Meeting (July 29 to Aug. 18) was attended by 544 students of whom 444 were women and 46 from foreign (chiefly Scandinavian) countries. The corresponding figures for 1912 are 565, 377, and 226. Considering that board and lodging were about twice and rail fares about three times as expensive as before the war, the popularity of the Summer Meeting is remarkable. Next July there will be held at Cambridge in connexion with the jubilee of the local lectures a conference on extra-mural teaching, the Chancellor presiding at the first meeting.

FROM the annual report for the year 1921-22 issued by the Rhodes Trust, it appears that the number of

Rhodes scholars in residence during the year was 300, of whom 156 came from the British Empire and the remainder from the United States. Of the total, 66—more than one-fifth—took natural science, a term which includes those studying medicine; in addition, forestry and mathematics each had five scholars, agriculture three and anthropology one. During the year, 72 took up their scholarships for the first time. The current academic year commenced with 262 scholars in residence. The value of the Rhodes scholarship has been temporarily increased by an annual bonus of 50*l.*, but applicants are warned that even thus, they must be prepared to find another 50*l.* a year. Appointments to the 1924 scholarships will be made during the year 1923; further information can be obtained from the offices of the Rhodes Trust, Seymour House, Waterloo Place, London, S.W.1.

THE Universities Bureau of the British Empire has published an abridged report of the proceedings of the annual conference of the universities of Great Britain and Ireland held last May. Four subjects were discussed: (1) the urgent need for enlarged opportunities for advanced study and research in the British universities; (2) the increase of residential accommodation for students; (3) specialisation in certain subjects of study by certain universities; (4) the organisation of adult education as an integral part of the work of the universities. Mr. H. A. L. Fisher, then president of the Board of Education, attended the conference and took part in the discussion of subject (3), which he considered to be pre-eminently a subject for conference and co-operation among the universities, especially in regard to the financial requirements of new specialised departments, the application to the best advantage of existing trust funds in universities, and the migration of research students. The Report (pp. 32, price 1*s.*) is obtainable from the Universities Bureau, 50 Russell Square, W.C.1.

THE eleventh annual conference of Educational Associations will be held at University College, Gower Street, W.C.1, on December 28-January 6, under the presidency of Sir Michael Sadler, Vice-Chancellor of the University of Leeds. The inaugural meeting will be held at Bedford College for Women, Regent's Park, on the afternoon of December 28, when Sir Michael Sadler will deliver his presidential address. There will be two joint conferences of all the societies during the meeting—one on the methods of carrying out in schools the recommendations of the reports on the Teaching of Classics, Modern Languages, English and Science, on December 30, and the other, "How can the Links in the Chain of Education be strengthened?" on January 5. The College of Preceptors will also hold a discussion, opened by Sir Michael Sadler, on the growth of bureaucracy in education. Among the papers which have been promised are: four to be delivered to the National League for Health, Maternity and Child Welfare—on physical development and its food requirements, by Dr. E. Pritchard, on physique and growth, by Dr. James Kerr, on child psychology and psychotherapy, by Dr. William Brown, and on health education, by Prof. H. Kenwood; three lectures on reform and tradition in education, by Mr. Frank Roscoe, and the College of Preceptors; a paper on the child and the cinema, by Dr. C. W. Kimmins, at the British Psychological Society (Education); another on the co-ordination of the teaching of mathematics with handicraft, by Mr. A. Romney Green, at the Society for Experiment and Research in Education; one on hygiene as applied to physical training, by Prof. M. E. Delafield, at the Incorporated British Association for Physical Training; and one on relativity, by Dr. Dorothy Wrinch, at the Association of Women Science Teachers.

## Calendar of Industrial Pioneers.

**December 24, 1872.** William John Macqueen Rankine died.—The author of a series of valuable engineering text-books, Rankine was a distinguished engineer and physicist, and with Clausius and Kelvin helped to found the modern science of thermodynamics. A student first at Glasgow Academy and then of the University of Edinburgh, he gained practical experience in railway engineering under M'Neill and Locke, and in 1855 succeeded Gordon in the chair of civil engineering in Glasgow University.

**December 25, 1868.** Linus Yale, Junior, died.—The son of Linus Yale, senior (1797–1857), a successful inventor of locks, Yale was born in 1831 and began life as a portrait painter. Joining his father in 1849 he contributed much to the success of the firm, and during 1860–64, by the adoption of an old Egyptian device, worked out his well-known pin-and-tumbler lock for the production of which the Yale Manufacturing Company was organised at Stamford, Connecticut.

**December 27, 1883.** Andrew Atkinson Humphreys died.—Humphreys graduated from the United States Military Academy, served in the Bureau of Topographical Engineers and the United States Coast Survey, and made a long study of the problem of controlling the waters of the Mississippi, his work on which raised him high among hydraulic engineers.

**December 27, 1890.** William John died.—Trained as a naval constructor under the Admiralty, John was regarded as one of the ablest and most original constructors of his day. He wrote on stability, the strength of iron ships, and other subjects, and from 1881 to 1888 was manager of the Barrow Shipbuilding Works.

**December 27, 1896.** Sir John Brown died.—One of the first to develop successfully the Bessemer process, Brown introduced into Sheffield the manufacture of steel rails, and at the Atlas Works, in 1863, rolled an iron armour plate twelve inches thick and fifteen to twenty feet long.

**December 27, 1900.** Sir William George Armstrong, Baron Armstrong of Cragston, died.—A solicitor, who became a great engineer, Armstrong was a pioneer in the use of hydraulic machinery, the rival of Krupp as an improver of artillery, and an organiser of outstanding ability. Born in Newcastle in 1810 he practised as a solicitor there; in 1846, he invented his hydraulic crane, and the following year became the first manager of the Elswick Engineering Works. In 1854 he brought out a breech-loading rifled gun, in 1859 founded the Elswick Ordnance Works, and in 1880 built a six-inch wire-wound gun. He was assisted by Rendel, Noble, Vavasseur, and others, and the Elswick Works were afterwards amalgamated with those of Mitchell and Swan and of Whitworth.

**December 28, 1907.** Coleman Sellers died.—A distinguished American mechanical engineer, Sellers was for many years connected with the firm of William Sellers and Co., of Philadelphia. Retiring in 1887 he became a consultant, and was actively engaged in the pioneering schemes for the utilisation of the power of the Niagara Falls.

**December 30, 1910.** Fredrik Adolf Kjellin died.—Known for his original work on electric smelting, Kjellin was trained at the Technical High School of Stockholm and became metallurgical chemist at the Gysinge works of the Aktiebolaget G. Benedicks, where, in 1899, he constructed the first induction furnace. E. C. S.

## Societies and Academies.

LONDON.

**Geological Society,** December 6.—Prof. A. C. Seward, president, and afterwards Mr. R. D. Oldham, vice-president, in the chair.—H. A. Baker: Geological investigations in the Falkland Islands. The stratigraphical succession comprises rocks of Archæan, Devonian-Carboniferous, and Permo-Carboniferous age. There is only one exposure of Archæan rocks, namely, in the cliffs of Cape Meredith, the southernmost point of West Falkland. Overlying these old rocks, and separated from them by a strong unconformity, are coarse sandstones and quartzitic rocks, nearly horizontal. This unfossiliferous series is of great thickness, probably about 5000 feet. It occupies the southern part of West Falkland and the islands lying to the west of this area. It is regarded as of Devonian age. The succeeding series of rocks, of Devonian-Carboniferous age, occupy the remainder of West Falkland (except for small areas of Permo-Carboniferous rocks) and the northern half of East Falkland. The Middle and Upper Series each include about 2500 feet of strata. Terrestrial deposits of Permo-Carboniferous age follow. They occupy a synclinalorium extending over the whole of the southern half of East Falkland (Lafonia) and Falkland Sound. They include a thickness of strata exceeding 9000 feet. A sandstone formation (Lafonian Sandstone) of no great thickness follows, and is, in turn, succeeded by more than 6000 feet of terrestrial deposits. Several thousand feet of these Upper Lafonian Beds consist of a monotonous alternation of thin sandstones and shaly beds. Doleritic dykes are of frequent occurrence; their age is post-Upper Lafonian. The marine fauna will probably prove to be of Upper Devonian age. The Falkland Islands appear to owe their existence to the fact that they occur at the crossing-place of two sets of folding movements.—A. C. Seward and J. Walton: On a collection of fossil plants from the Falkland Islands. A Devonian age is suggested for the oldest plant-bearing beds. Numerous examples of *Glossopteris* leaves were collected, especially in Lafonia, of species which are not confined to one geological series in the Gondwana System. Many specimens of *Equisetaceae* stems were also obtained from the *Glossopteris* Beds: of these several are identical with Falkland examples described by A. G. Nathorst and by T. G. Halle, while others are compared with an Upper Triassic or Rhætic species *Neocalamites carrerei* (Zeiller). A comparison of petrified wood, most of which has been assigned by various writers to the genus *Dadoxylon*, from different parts of Gondwanaland, points to the prevalence, in the southern botanical province, of trees differing in anatomical characters from contemporary plants in the northern province. The Permo-Carboniferous flora seems to agree most nearly with the Madaga and Beaufort Series of India and South Africa respectively. The stems compared with *Neocalamites* favour a reference of the beds at Cygnet Harbour and Egg Harbour to a somewhat higher position; and, on the other hand, the leaves described as *Glossopteris indica* Schimper (cf. *G. decipiens* Feistmantel) from North Arm, although they represent a type which has a wide range both in space and in time, suggest a possible correlation with the Ecra Series of South Africa and the Talchir Series of India.

CAMBRIDGE.

**Philosophical Society,** November 27.—Mr. C. T. Heycock, president, in the chair.—C. T. R. Wilson: On some  $\alpha$ -ray tracks. (1) The track of an  $\alpha$ -particle from an atom of thorium emanation, together with

that of the  $\alpha$ -particle emitted immediately afterwards by the resulting thorium-A atom. Some remarkable features on these tracks were explained as due to the action of previously formed tracks in robbing the air of its excess of water vapour. (2) Photographs of  $\alpha$ -ray tracks showing short-range  $\beta$ -rays radiating from them—Bumstead's  $\delta$ -rays, of which photographs were obtained by him in hydrogen. From the range of the longest  $\delta$ -rays their velocity reaches values twice that of the  $\alpha$ -particle. The  $\delta$ -rays do not appear on the last two centimetres of the  $\alpha$ -ray tracks. In the neighbourhood of the initial portions of the  $\alpha$ -tracks minute detached cloudlets are visible—probably the tracks of  $\beta$ -particles produced by soft X-rays (K-radiations from atoms traversed by the  $\alpha$ -particle).—A. B. Appleton: The interpretation of the pelvic region and thigh of Monotremata. An extensive comparison of thigh musculature forms an essential preliminary to the tracing of changes in the form of the femur and pelvis among Tetrapoda. The destination of nerve-fibres and their course in regard to pelvic-girdle and muscles provide the best guide to the identification of muscles. The myology and nerve-distribution of various mammalian and other tetrapod groups has been carried out as a preliminary to the identification of Monotreme muscles. Monotremata exhibit most of the characteristics of the mammalian thigh. A somewhat divergent evolution has taken place with retention of certain reptilian features. The lesser trochanter of mammalia is a different structure from the internal trochanter of reptilia.—A. B. Appleton and F. Goldby: Observations on the innervation of the pubi-tibialis (sartorius) muscle of Reptilia. In some species of Lacertilia it is innervated from two nerve-trunks, as in *Sphenodon*. This is regarded as due to fusion of two muscle-elements. Certain Mammalia, Monotremata and certain Carnivora almost reproduce this form. In most other Mammalia, the pubi-tibialis muscle is represented only by the sartorius muscle (possibly also by the gracilis muscle), and the function has changed.—W. Burnside: The axioms of elliptic geometry.—W. M. H. Greaves: The periodic solutions of the differential equation for the triode oscillator.—C. G. F. James: Complexes of cubics in ordinary space.

## EDINBURGH.

Royal Society, December 4.—Prof. J. W. Gregory, vice-president, in the chair.—Sir J. A. Ewing: The atomic process in magnetisation: further notes. A modified form of atomic model has been made which reproduces the distinctive features of both ferro- and paramagnetism. Taken in conjunction with Langevin's theory of diamagnetism, the new model appears to offer a general clue to the process of magnetisation in any solid body, whether ferromagnetic, paramagnetic, or diamagnetic. It is now generally recognised that the electrons, in consequence of orbital motion or otherwise, are in some way magnetic di-poles. If their grouping is not rigid and allows individual electrons to have their magnetic axes reversibly deflected against a strong controlling force, we find the phenomena of paramagnetism. As regards ferromagnetism, the group might be initially unsymmetrical, having a resultant moment, so that it could serve as the Weber element in a ferromagnetic process. In that case the phenomena of hysteresis are found when the group as a whole turns from one position of stability to another. The control under which such irreversible turning takes place is probably partly in the mutual action between the outer shell of electrons of any one atom and those of its next neighbours in the space-lattice,

as well as in the mutual action from atom to atom of the groups which constituted the Weber elements. The magnetic axes of the groups tend to orient themselves in rows. At first, the group of electrons in each atom is deflected reversibly through a small range, after which there is a break away, and new rows are formed with a more favourable orientation. The control which causes the range of reversible deflection to be very narrow (as, for example, in iron) is ascribed to the forces (not exclusively magnetic) between electrons in juxtaposition in the outer shells of atoms. The contiguous atoms are regarded as turning simultaneously under the influence of the applied field, first reversibly through a small angle, and then irreversibly into new lines, which, in an iron crystal, are inclined at  $90^\circ$  or  $180^\circ$  to the old ones. When all the groups are turned in one direction, the magnetism is what is called saturated, but there may be a further increase of the magnetism through the reversible turning of the individual electron axes within any group.—A. P. Laurie: Experiments with a model to illustrate the combination of two atoms consisting of magnetons round a positive nucleus. If two atoms composed of rings of magnetons placed radially round a positive nucleus approach each other, then the magnetic lines of force between the two atoms are such that there must be two places of equilibrium for the two nearest magnetons—one in which they are when the atoms approach, and the other the position at right angles to this holding the two atoms together by means of the outer electrons. A model to illustrate this (Figs. 1 and 2) was constructed with four fixed coils to represent two of the outer magnetons of two separate atoms

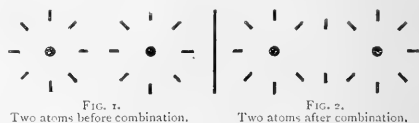

FIG. 1. Two atoms before combination.

FIG. 2. Two atoms after combination.

and with two moving coils, each able to turn on its own centre and on a common centre between them. On passing an electric current through the system the moving coils always arranged themselves in one position or another at right angles according to the placing of the four fixed coils. This suggests a new theory of valency—a valency not depending on the number of magnetons in the outer shell, but on the number of groups of three magnetons. There would be primary, secondary, and tertiary valencies, the combination of two atoms at once producing fresh groups of three electrons which lead to new valencies. An explanation of chemical combination is offered.—A. E. M. Geddes: Observations on the structure of the hydrogen lines  $H_\alpha$  and  $H_\beta$ . Sommerfeld's theory demands a constant frequency separation of the components of spectral lines. The results obtained tend to indicate a gradual decrease in the separation. This appears to support M'Lennan's idea that the frequency separation gradually diminishes and vanishes at the limit of the Balmer series.—D. M. Y. Sommerville: Division of space by congruent triangles and tetrahedra. The various ways in which it is possible to divide the plane into congruent triangles, and space of three dimensions into congruent tetrahedra, is discussed.—Sir Thomas Muir: The theory of alternants from 1896 to 1917.—H. W. Turnbull: Double binary forms. The  $(m, n)$  form  $\sum \binom{m}{i} \binom{n}{j} a_{ij} z_1^m z_2^{n-i-j}$ ,  $\alpha^i h^i m$ ,  $\alpha^i h^i n$  is binary in both independent variables  $z_1, z_2$ . Relative to the independent linear transformations from  $z$  to  $z_1$ ,



$w, w_1$  an invariant theory can be constructed. This theory has been studied principally by Peano, Kasner, and Forsyth, but only for values of  $m, n$ , not exceeding 2. The present paper is preparatory to a proof of Gordan's theorem—that the complete invariant system of the  $(m, n)$  form is finite. It is the algebraic theory answering to geometrical inversion.

## PARIS.

Academy of Sciences, November 27.—M. Emile Bertin in the chair.—**Marcel Brillouin**: Einsteinian gravitation. Statics. Singular points. The material point. Various remarks.—**E. Fournier**: Experiments on the guidance of dirigible balloons through fog by the method of W. A. Loth: their consequences. The electrical method of M. Loth, originally designed for the guidance of ships into port in foggy weather, is equally applicable to aeroplanes and balloons. The guiding cable may be either aerial or buried in the earth. The latter method might be employed in establishing aerial communications across the Sahara.—**L. Guignard**: The existence of certain proteid bodies in the pollen of various Asclepiadaceae.—**Charles Richet** and **Mme. A. G. Le Ber**: Studies on lactic fermentation. The action of very small doses of substances apparently inoffensive. Substances such as urea or milk, not considered poisonous, can exercise, even at very great dilutions, a distinct influence on the activity of the lactic ferment. It follows that bacteria, since they react to such slight influences, are never found under identical conditions of development.—**A. de Gramont**: Ultimate lines and spectral series.—**P. Fatou**: Certain uniform functions of two variables.—**Spyridon Sarantopoulos**: The number of roots of holomorphic functions in a given curve.—**Alf. Guldberg**: Mean values.—**Jacques Rueff**: Theory of the phenomena of exchange. Two principles are enunciated giving the relations between rates of exchange and purchasing power of money in different countries, excluding countries practising continuous inflation. The principles are verified by constructing curves of the purchasing power of the franc in England, the United States, Italy, and Spain, over a series of years.—**A. Buhl**: The secular movement of the perihelion of Mercury.—**Rodolphe Soreau**: The laws of variation with altitude, in the troposphere, of the characteristics of standard air.—**Henri Fabre**: Hovering flight in the Mediterranean. The flight of a bird (probably the puffin) has been studied; it rarely flies in calm weather, and when forced to do so its flight resembles that of a duck. But as soon as the wind velocity and height of the waves reach certain definite values, the bird flies with motionless wings. The explanation of this flight is based on the hypothesis that vertical air-currents are produced by the wind striking the waves. There must be both ascending and descending air-currents, but the bird utilises only those ascending currents the direction of which is controlled by the direction of the crests of the waves.—**W. D. MacMillan**: Can the mean density of the Universe be finite?—**Emile Borel**: Remarks on the preceding communication.—**Ch. Maurain** and **Mme. de Madinéc**: Evaluation of the intensity of the vertical electric currents traversing the soil in France.—**R. Boulouch**: The aplanatic telescope.—**R. Jouaust**: The application of pyrometers to high frequency measurements. The Féry pyrometer can be utilised in some measurements necessary in radiotelegraphic installations. Two examples are given, the calibration of high frequency ammeters and the measurement under working conditions of the resistance of the oscillating circuit of a lamp generating station.—**L. Gaumont**: A new sound amplifier. The vibrating part of this apparatus consists of a silk cone on which is coiled

a spiral of fine aluminium wire; the cone is fitted between the poles of an electromagnet, similarly shaped. The telephone currents pass round the spiral wire on the cone, which is set in vibration by the action of the magnetic field. The sound is magnified without distortion, and one apparatus had a range of hearing of 300 metres.—**P. Lemay** and **L. Jalouste**: Some microbiological consequences of the oxidising properties of thorium-X. Earlier researches showed that the radioactive elements behave as oxidising catalysts. This suggested that thorium-X should favour the growth of aerobic organisms and slow down the development of anaerobic organisms. Experimental proof of the correctness of this view has been obtained, using *B. lacticus* and *B. butyricus* as the test organisms.—**P. Loisel** and **Michalesco**: The radioactivity of the springs of the Baths of Hercules in Roumania. The waters from four of seven springs examined show marked radioactivity, in amounts varying with date of collection.—**Léon Guillet** and **Marcel Ballay**: The vapour pressure of some copper-zinc alloys in the solid state. The vapour pressure of zinc in brass (zinc 44.8 per cent.) varied between 3.0 mm. at 535° C. and 19.32 mm. at 630° C. In the presence of air, the loss of zinc was smaller than in nitrogen, hydrogen, or carbon monoxide.—**MM. Dervin** and **Olmer**: Ammoniacal silver fluoride. This compound has the composition  $\text{AgF} \cdot 2\text{NH}_3 \cdot 2\text{H}_2\text{O}$ . On careful heating it loses water, ammonia, and ammonium fluoride, leaving an explosive nitride,  $\text{Ag}_3\text{N}$ .—**J. Valentin**: The solidification of the system  $\text{MgCl}_2 \cdot \text{KCl} \cdot \text{BaCl}_2$ .—**Paul Pascal**: Magnetic analysis of the stannic acids. Measurements of the magnetic susceptibility of stannic oxide in various states of hydration give no evidence of the formation of any definite stannic acids.—**F. W. Klingstedt**: The ultraviolet absorption spectra of toluene and the xylenes. The three xylenes possess very different absorption spectra.—**Louis Grenet**: A possible modification of the iron-cementite diagram.—**L. J. Simon**: The influence of the structure of organic compounds on their oxidation by chromic and sulphuric acids. The combustion of organic compounds by the chromic-sulphuric acid mixture is not always complete, and from the data given, there would appear to be a relation between the amount of carbon escaping combustion and the molecular structure of the compound.—**André Brochet**: Some properties of the active nickel employed as catalyst in organic chemistry.—**Marcel Delépine**: The iridio-dipyridino-tetrachlorides  $\text{M}[\text{Ir}(\text{C}_5\text{H}_5\text{N})_2\text{Cl}_4]$ .—**M. Faillébin**: The hydrogenation of aldehydes and ketones in the presence of pure and impure platinum black. The reduction of aldehydes and ketones to the corresponding alcohols by hydrogen with pure platinum black as a catalyst gives bad yields: there is a tendency for the formation of hydrocarbons, and the catalyst becomes rapidly fatigued. If the platinum black is made from a solution of chlorplatinic acid containing ferric chloride, the impure catalyst gives excellent yields of alcohols.—**G. Delépine** and **V. Milon**: The presence of Waulsortian reefs in the carboniferous limestone of the Laval basin.—**L. Barrabé**: The presence of transferred strata in the eastern Corbières.—**F. Roman**: The quaternary terraces of the upper valley of the Tagus.—**Albert Nodon**: Researches on solar action at a distance.—**V. Schaffers**: Lightning and trees.—**E. Roger**: The periodic return of severe winters. In 1860 Renou noted that severe winters recur periodically. The author gives additional data in support of this, and puts the period as 41 years.—**E. Fichot**: The constitution of oceanic areas in basins of resonance, originating from continental masses under the action of the tides.—**G. Hamel**: Some peculiarities

of the algologic flora of Saint Malo.—P. Mazé: The practical conditions for using calcium cyanamide as a manure. The best way to apply calcium cyanamide to the soil is to mix it with peat.—Ch. Brioux: The comparative assimilability of calcium phosphate and the phosphates of iron and alumina. Plants can assimilate phosphorus from the phosphates of aluminium and iron, and from the experiments described the facility of assimilation of phosphorus from the phosphates of aluminium, calcium, and iron is in the order given. From this it follows that in determining the useful phosphorus in manures the solvent employed should attack not only the phosphates of the alkalis, lime and magnesia, but also phosphates of iron and alumina.—A. Pézard and F. Caridroit: The action of the testicular hormone on the relative valency of the allelomorphous factors in sheep (Dorset and Suffolk).—H. Barthélemy: Maturation *in vitro* and activation of the eggs in the general cavity and conduits in *Rana fusca*.—Paul Portier and Marcel Duval: Osmotic pressure of the blood of the "wiped" eel as a function of modifications of the salinity of the external medium. The mucus abundantly secreted at the surface of the skin of the eel has a marked influence on the isolation of the internal medium. The partial or complete removal (by wiping the surface) of this protective medium causes an increase in the osmotic pressure of the blood serum when the salinity of the external medium is increased.—Ed. Le Danois: The prediction of the value of the herring catch in winter. The prediction is based on the study of the 14° C. isotherm at 50 metres depth in August, and the assumption that the movements of the herring are governed by the temperature of the water. The fishing results this winter have confirmed this view.—Louis Roule: The ecology of the sturgeon (*Acipenser sturio*) in the Atlantic regions of France.—H. Hérissey: The biochemical synthesis of *D*-mannoside starting from mannanes.—Emile F. Terroine, E. Brenckmann, and A. Feuerbach: The identity of composition of organisms of the same species after death by starvation.—G. Marinresco: The rôle of oxidising ferments in the production of fevers and inflammations.

## BRUSSELS.

Royal Academy of Sciences, October 14.—M. A. Lamcere in the chair.—C. Cesáro: The blue crystals of disthene found at Katanga. Facility of the  $g_1$  cleavage. The angle of extinction on  $g_1$  and in the other faces of the vertical zone. Corresponding faces. The results of a detailed crystallographic examination of small crystals of disthene, collected in Katanga sands. The same sand contained a single crystal of euclase, a mineral not hitherto found in the Congo.—Leon Fredericq: New Belgium. The colony of arctic-alpine animals and plants found on the Baraque Michel plateau is exceptional and is not found to the same extent on the other high plateaux of New Belgium, notably at Losheimergraben. This phenomenon appears to be connected with the local anomaly of temperature which characterises the climate of the Baraque Michel.—Maurice Nuyens: The trajectory of an electrified point in the field due to an electron.—H. Buttenbach: Note on kasolite. The results of a crystallographic examination of kasolite, found along with pitchblende in the Katanga copper mines.—Charles Fraipont: Observations on the large Pleistocene Felidae.  
November 4.—J. Neuberg: Geometry and mechanics.—N. Saltykow: The development of the theory of partial equations of the first order of a single unknown function.—Paul Brien: Researches on the embryogeny of *Salpa maxima*.

## SYDNEY.

Linnean Society of New South Wales, October 25.—Mr. G. A. Waterhouse, president, in the chair.—R. J. Tillyard: Mesozoic insects of Queensland. No. 9. In the Protorthoptera a large number of fragments of the peculiar *Mesorthopteron locustoides* Till. enables a full restoration of the wing to be made. Two new genera and species are described in the Orthoptera, one related to mantids, the other a very elongated locustoid type. In the Odonata a practically complete wing of an Archizygopteron forming the type of a new family is discussed. In the Hemiptera a large number of new types are dealt with, including the first Triassic record of representatives of the Cryptocerata or water-bugs, and several new Homoptera belonging to the Scytinopteridae, Tropiduchidae, Cixiidae, and Ipsviciidae.—A. J. Turner: Some Australian moths from Lord Howe Island. Ship traffic plays an important part in the introduction of Australian species of Lepidoptera into Lord Howe Is., Norfolk Is., and New Zealand.—Vera Irwin-Smith: Notes on nematodes of the genus *Physaloptera*. Pt. iv. The Physaloptera of Australian Lizards (contd.). Two new species and a larva found encysted in the body cavity of *Himulia tenuiolatum* are described. The cyst-forming habit was not known before in the genus, and Physaloptera have never been recorded, hitherto, outside the alimentary canal.—G. D. Osborne: The geology and petrography of the Clarence town-Paterson district. Pt. ii. The larger faults are connected with the folding movements which produced asymmetric plunging folds as the outcome of thrusting due to the subsidence of the sub-oceanic segment of the Pacific. The age of the faulting and folding is probably post-Upper Marine and pre-Triassic. A comparison between the plan of the outcrop of the Bolwarra conglomerate in the Permian Series and that of the Paterson toscanite in the Kuttung Series gives evidence of differential crumpling of these two series.

## Official Publications Received.

British Astronomical Association. Handbook for 1923. Pp. 38. (London: Eyre and Spottiswoode, Ltd.) 2s.  
Dove Marine Laboratory, Cullercoats, Northumberland. Report for the Year ending June 30th, 1922. Edited by Prof. Alexander Meek. Pp. 105. (Cullercoats.) 5s.  
Madras Fisheries Experiment. Bulletin No. 13: Administration Report, 1919-20, by the Hon. Mr. A. Y. G. Campbell; Remarks on Canning and Manufacture of Fish Oil and Gumbo, by Sir F. A. Nicholson. (Reports Nos. 1, 2 and 3 of 1921.) Pp. 266. (Madras: Government Press.) 3.2 rupees.

## Diary of Societies.

## THURSDAY, DECEMBER 28.

ANNUAL CONFERENCE OF EDUCATIONAL ASSOCIATIONS (at Bedford College for Women), at 3.—Sir Michael Sadler: Presidential Address.  
ROYAL INSTITUTION OF GREAT BRITAIN, at 3.—Prof. H. H. Turner: Six Steps up the Ladder to the Stars. (1) The Distance of the Stars. (Juvenile Lectures.)

## FRIDAY, DECEMBER 29.

EUGENICS EDUCATION SOCIETY (at University College), at 3.  
Y.M.C.A. (at University College), at 3.—Sir Arthur Yapp and others: The Y.M.C.A. and Adult Education.  
NATIONAL LEAGUE FOR HEALTH, MATERNITY, AND CHILD WELFARE (at University College), at 5.30.—Dr. E. Pritchard: Physical Development and its Food Requirements.  
JUNIOR INSTITUTION OF ENGINEERS, at 7.30.—C. F. Morgan: Brewery Engineering.

## SATURDAY, DECEMBER 30.

ROYAL INSTITUTION OF GREAT BRITAIN, at 3.—Prof. H. H. Turner: Six Steps up the Ladder to the Stars. (2) The Discovery of the Planet Neptune. (Juvenile Lectures.)

# NATURE



A WEEKLY ILLUSTRATED JOURNAL OF SCIENCE.

*"To the solid ground  
Of Nature trusts the mind which builds for aye."*—WORDSWORTH.

No. 2774, VOL. 110] SATURDAY, DECEMBER 30, 1922 [PRICE ONE SHILLING

Registered as a Newspaper at the General Post Office.

[All Rights Reserved.]

## NEWTON'S (New Model) "DEMONSTRATOR'S" LANTERN

For all classes of  
Projection Work.

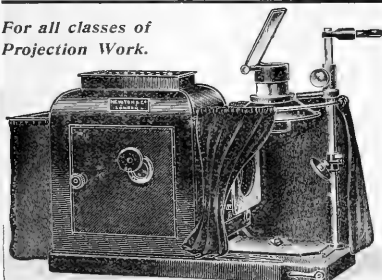

Price List sent on application.

NEWTON & Co., 72 Wigmore St., London, W.1.  
(Specialists in Optical Projection Apparatus.)

## CHEMICALS

Analytical, Technical and A.R.

REGD. TRADE MARK **APPARATUS**



Balances  
**BENCHES**

Fume Chambers, etc.,

for

Chemical, Physical, and  
Technical Laboratories.

Price Lists and Estimates on Application.

Wireless Apparatus and Accessories supplied.

Also New Catalogues of Chemical Apparatus and Chemicals.

**REYNOLDS & BRANSON, LTD.,**

Contractors to the War Office, Admiralty and  
Egyptian Government, &c.

14 COMMERCIAL STREET, LEEDS.

## BAIRD & TATLOCK (LONDON) LTD.

SCIENTIFIC INSTRUMENT MANUFACTURERS  
and LABORATORY FURNISHERS.

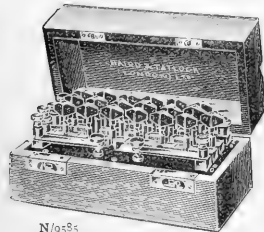

N/9585  
RESISTANCE BOX

Physical  
Apparatus  
for  
Schools  
and  
Colleges.

14-15 CROSS STREET, HATTON GARDEN, LONDON E.C.1

## WIRELESS APPARATUS

Complete sets in stock  
also———components

Call or write

**NEGRETTI & ZAMBRA**  
38, HOLBORN VIADUCT, E.C.1.  
LONDON.

**NOTICE.**—In consequence of the Holidays the issue of NATURE for the week ending January 6 may not be in the hands of Subscribers and others until Saturday, instead of Friday, as usual.

The number will begin a new volume and contain, in the series of SCIENTIFIC WORTHIES, an article on Prof. H. A. Lorentz, For.Mem.R.S., accompanied by a separate photogravure plate portrait, proofs of which, on India paper, will be published at 5s. net.

ST. MARTIN'S STREET, LONDON, W.C.2.

### UNIVERSITY OF LONDON.

The Senate invite applications for the UNIVERSITY CHAIR of ZOOLOGY (tenable at Bedford College. Salary £800 a year. Applications (12 copies) must be received not later than first post on April 16, 1923, by the ACADEMIC REGISTRAR, University of London, South Kensington, London, S.W.7, from whom further particulars may be obtained.

### THE QUEEN'S UNIVERSITY OF BELFAST.

#### DEPARTMENT OF PHYSICS.

APPLICATIONS are invited for the LECTURESHIP in PHYSICS. Salary £450 per annum. Particulars of the appointment may be had from

J. M. FINNEGAN, Secretary.

### EAST LONDON COLLEGE (UNIVERSITY OF LONDON).

#### CHEMICAL DEPARTMENT.

Professor—J. K. PARTINGTON, M.B.E., D.Sc.

DEMONSTRATOR required for January 15. Special qualifications in Organic Chemistry. Appointment for two terms in the first instance. Salary £125-£150 a term, according to qualifications. Applications should be forwarded at once.

E. J. WIGNALL, Registrar.

### APPRENTICES.—The Firm of C. BAKER

(Established 1765), Scientific and Optical Instrument Manufacturers, have vacancies on their staff for 2 Apprentices. A unique opportunity is presented for a thorough training, both technical and commercial. Premium required. C. BAKER, 244 High Holborn, London.

The Misses FARRAN  
10 Bell Yard, Temple Bar, W.C.2,  
HAVE CONSIDERABLE EXPERIENCE IN  
**COPYING SCIENTIFIC MS.**  
AND ARE PREPARED TO  
UNDERTAKE ANY QUANTITY.

### DUSTLESS ROOMS

On all Laboratory, Library, Museum, School, &c.,  
Floors and Linoleums of every description

## USE FLORIGENE (Regd.)

DURING the VACATION for BEST RESULTS

It is **IMPORTANT to NOTE** that **ONE APPLICATION** of "Florigene" **ALLAYS** the **DUST** and **DIRT** for 2 to 12 months, according to traffic, not only during each Sweeping (without Sprinkling of any kind, but also throughout all the intervening periods—which is of greater hygienic importance. Easily applied.

These sanitary and labour-saving advantages are **NOT** attained by sweeping-powders or any other method.

Send for Particulars, Medical Reports, and Testimonials to the Sole Makers

The "DUST-ALLAYER" Co.

4 VERNON PLACE, BLOOMSBURY, LONDON, W.C.1.  
*Contractors to Admiralty, H.M. Office of Works, Colonial Govts., L.C.C., etc.*

### THE HANDBOOK OF PATENT LAW OF ALL COUNTRIES

By W. P. THOMPSON, F.C.S., M.I. Mech.E., Etc.,

Chartered Patent Agent of Liverpool.

Entirely revised and rewritten 1920. 157 pages. Crown Octavo.

All Countries, 6s. British Law only, 1s.

"Should prove a very valuable and trustworthy guide to would-be patentees."—*Nature*.

LONDON: STEVENS AND SONS, LIMITED.

### MESSRS. SOTHERAN

have now opened a Scientific Department on the first floor of their Strand House, where a selection of their large stock in modern, as well as old and rare, works on Exact and Applied Science may be seen on the shelves.

They would also call attention to their facilities in getting sets or runs of periodicals on scientific subjects, as well as rare or out-of-print books they may not have in stock already.

HENRY SOTHERAN & CO., 140 STRAND, W.C.2, & 43 PICCADILLY, W.1, LONDON.

# LEWIS'S CIRCULATING LIBRARY

of Scientific, Technical,  
and Medical Books

covering the widest range of subjects, pure and applied.



NEW BOOKS and EDITIONS are added in UNLIMITED SUPPLIES, as long as the demand requires, delay or disappointment thus being prevented.

ANNUAL SUBSCRIPTION (Town or Country) FROM ONE GUINEA according to the number of books required at one time.

Subscriptions may commence from any date.

Books may be retained as long or exchanged as frequently as desired.

The READING AND WRITING ROOM (first floor) is open daily.

Prospectus, with Quarterly List of Additions, post free.

H. K. LEWIS & CO. Ltd.,

136 Gower Street, and 24  
Gower Place, London, W.C.1.

District Railway: Easton Square Station. All Tube Railways: Warren Street.



SATURDAY, DECEMBER 30, 1922.

## CONTENTS.

	PAGE
The Development Commission . . . . .	865
The Petroleum Industry . . . . .	866
Unified Human History. By F. S. Marvin . . . . .	867
Naturalisation of Animals and Plants. By Dr. James Ritchie . . . . .	868
Boscovich and Modern Science . . . . .	870
Our Bookshelf . . . . .	871
Letters to the Editor:—	
A Type of Ideal Electric Atoms.—J. L. . . . .	873
Cambridge and the Royal Commission.—Sir William Ridgeway; The Writer of the Article . . . . .	873
Gravity Variations.—Sir G. P. Lenox-Conyngham, F.R.S.; C. S. Wright . . . . .	874
Action of Cutting Tools. (With diagrams).—Prof. Alan Pollard; Prof. E. N. da C. Andrade . . . . .	875
The Secondary Spectrum of Hydrogen.—A. C. Menzies . . . . .	876
Science and the Empire.—Maj. A. G. Church . . . . .	876
The Hermit-crab ( <i>E. bernhardus</i> ) and the Anemone ( <i>C. (Sagartia) parasitica</i> ).—Dr. J. H. Orton . . . . .	877
Winter Thunderstorms.—Capt. C. J. P. Cave . . . . .	877
The Corrosion of Ferrous Metals. (Illustrated.) By J. N. F. . . . .	878
The American Museum of Natural History. (Illustrated) . . . . .	880
Presentation to Sir Edward Sharpey Schafer, F.R.S. (Illustrated) . . . . .	882
Obituary:—	
F. B. Bryant . . . . .	882
Current Topics and Events . . . . .	883
Our Astronomical Column . . . . .	886
Research Items . . . . .	887
Weather Cycles in Relation to Agriculture and Industrial Fluctuations . . . . .	889
Geology of the North Sea Basin . . . . .	890
New Japanese Botanical Serials . . . . .	891
Colloid Chemistry. By Prof. W. C. McC. Lewis . . . . .	891
Early History of the Sussex Iron Industry . . . . .	893
University and Educational Intelligence . . . . .	893
Societies and Academies . . . . .	894
Official Publications Received . . . . .	896
Diary of Societies . . . . .	896

Editorial and Publishing Offices:

MACMILLAN &amp; CO., LTD.,

ST. MARTIN'S STREET, LONDON, W.C.2.

Advertisements and business letters should be addressed to the Publishers.

Editorial communications to the Editor.

Telegraphic Address: PHUSIS, LONDON.

Telephone Number: GERRARD 8830.

NO. 2774, VOL. 110]

The Development Commission.<sup>1</sup>

THE Development Commissioners have just issued a report on their operations during the year ended in March last. For a Blue-book it is an unusually interesting document, containing as it does many verbatim reports from Directors of Research who do not disdain, on occasion, the aid of the poets in describing their labours. We may instance Mr. W. B. Hardy on fishery research:

"The frontal attack," he says, "usually called, 'taking a practical view' of the problem, often fails, and rarely gives more than a partial and incomplete solution.

"Scientific history shows that the solution of a problem more often than not comes from a direction totally unexpected—

"For while the tired waves, vainly breaking,  
Seem here no painful inch to gain,  
Far back, through creeks and inlets making,  
Comes, silent, flooding in, the main."

And the corollary is well expressed:

"The search for the fundamentals of knowledge must remain the business of specialists trained to the use of the test tube and microscope. But it is one of the gravest fallacies responsible for the suspicion with which the 'practical' man often views science, which represents the work of the specialist as something different from that of the man engaged in the day-to-day employment of industry."

No man has a wider contact with research in its practical outcomes than has Mr. Hardy, and no one is entitled to speak with greater authority on the State organisation of research.

In the year under report the Development Commissioners recommended the expenditure of 368,450*l.*, of which 41,372*l.* was by way of loan. The grants to agriculture amounted to 226,253*l.* Under the head of fisheries the grants recommended totalled 71,218*l.* Fishery research workers appear to be in the happy position of explorers of a new and rich country, and the Commissioners were well advised in devoting a large section of their report to a detailed review of the progress made in the solution of fishery problems. As the British sea fisheries alone provide about 13 million tons of fish annually, it is clear that even the wide seas about our coasts cannot continue to furnish such a quantity unless the increased control which increased knowledge alone will bring comes to the rescue. Of this knowledge and the need for its extension, here is an example:

"The study of the edible crab," says Mr. Hardy, "now in progress at Aberdeen, has revealed the fact that there is a steady migration from the East Coast to the Moray Firth. One marked crab was found to

<sup>1</sup> Twelfth Report of the Development Commissioners for the year ended March 31, 1922. H.M. Stationery Office. 3*s.* 6*d.*

have covered over 100 miles of coast in just about as many days. All the lines of migration meet at a point in the Moray Firth. Why? We do not know, but it is something gained to have established the fact of the migration."

Another interesting discovery is a method of purifying mussels (and, probably, oysters too) by treating them with chlorinated water and thereby inducing them to cleanse themselves of sewage bacteria. Researches in plankton are proceeding vigorously at many research stations. This, of course, provides the most fundamental problem of all. Just as the harvest of the land depends, ultimately, on the activities of certain microscopic organisms in the soil, so the harvest of the sea depends, in the long run, on the microscopic organisms it contains. It is interesting to learn that, equally with the soil workers, fishery investigators are giving much attention to hydrogen ion concentration. In sea water, this measure of acidity appears to be correlated with the content of organic matter. Perhaps the most important fishery problem is connected with the herring. The mysterious movements of this fish, affecting as they do the livelihood of thousands of persons, have been celebrated in song and story. Shoals may suddenly desert waters which they have frequented for centuries. The Hanseatic League (a German domination of England) was terminated in the fifteenth century largely by the failure of the herring fishery in the Baltic; within living memory, the herring has deserted Loch Fyne in Scotland. As the Scottish song, "Caller Herrin'" runs:

"You may ca' them vulgar farin',  
Wives and mithers, maist despairin',  
Ca' them lives o' men."

The problem is as yet unsolved, but it is the business—and the certain hope—of science to solve it.

Of the many forms of State organisation of research, that under which fishery investigations are regulated appears to be one of the best. In outline there is provision for (1) "free" and (2) "directed" research. The latter is devoted to the solution of definite economic problems, whereas the former is concerned with the study of fundamental problems which lie at the root of any advance in the practical sphere. But no attempt has been made to lay down a definite border line. Controlling both there is an Advisory Committee of scientific men, the advice of which the Commissioners appear to accept unhesitatingly.

We notice that the various Agricultural Research Institutes continue to produce much valuable work, though the section of the report devoted to agricultural research does not include much new matter of interest.

The report does not contain, as in the past, an account of the present finances of the Fund. In an

article published in NATURE for April 8 (vol. 109, p. 433) some apprehension was expressed on the score of the low ebb which last year's report showed the Fund had reached. Having survived the attack of the Geddes Committees, it would be indeed unfortunate if the future of fishery research should prove to be still uncertain, while it is equally necessary that the valuable researches of such institutions as the Plant Breeding Stations should be continued and placed on a permanent basis.

### The Petroleum Industry.

*The Petroleum and Allied Industries: Petroleum, Natural Gas, Natural Waxes, Asphalts and Allied Substances, and Shale Oils.* By James Kewley. (The Industrial Chemistry Series.) Pp. xi + 302. (London: Baillière, Tindall, and Cox, 1922.) 12s. 6d. net.

THE literature concerned with petroleum and its products is becoming almost as extensive as that which relates to coal. But whereas that of coal is the growth of some centuries, the literature of petroleum has been accumulated within living memory. This is due, of course, to the extraordinary development of the use of petroleum as a source of light and heat. The growth of motor transport has been remarkable, due in no small measure to the influence of the Great War, directly and indirectly. Aviation has arisen wholly within our own time, and is one of the most striking of the new departures which the twentieth century has witnessed. The exploitation of our oil-fields has become a question of national importance, and, it may be added, of international difficulty. The growth in the use of petroleum is well illustrated by the subjoined table, taken from the recently published Report of Lloyd's Register of Shipping for the year 1921-1922, showing the progressive demand for oil-carrying vessels:

		Oil-tankers.	
July 1914	. .	1,478,988	gross tons.
July 1919	. .	2,929,113	"
July 1920	. .	3,354,314	"
July 1921	. .	4,418,688	"
July 1922	. .	5,062,699	"

It is further shown by the increase in gross tonnage of vessels either originally fitted to burn oil fuel or subsequently converted for that purpose:

		Vessels fitted for burning oil fuel.	
July 1914	. .	1,310,209	gross tons.
July 1919	. .	5,336,678	"
July 1920	. .	9,359,334	"
July 1921	. .	12,796,635	"
July 1922	. .	14,464,162	"

Additional evidence is furnished by the large increase

in the number of motor vessels during the same interval :

	Motor Vessels.	
	Number.	Gross tons.
July 1914 . . .	297	234,287
July 1919 . . .	912	752,606
July 1920 . . .	1178	955,810
July 1921 . . .	1473	1,248,800
July 1922 . . .	1620	1,542,160

These statistics, it must be understood, are those recorded in the Register books of the society, and are probably an underestimate of the growth which has actually occurred throughout the world. They are, nevertheless, highly significant and instructive, and serve to illustrate what is a great factor in world-wide progress, and eminently characteristic of our own age.

The book under review may be recommended as a concise and well-informed account of the rise and growth of this important industry. It is well arranged and well written, and considering its limitation as to space, deals in sufficient detail with its more important phases. It is divided into nine main sections, or parts, each of which is further subdivided into several subsections. The classification is rational, and conduces to a logical treatment of the subject-matter.

Part I. is introductory, and treats of the terminology of petroleum products and of the history of the petroleum industry; of the chemistry, geology, and mode of origin of natural petroleum. Part II. is concerned with natural gas, its occurrence, distribution, composition, and applications. Part III. treats of crude petroleum, its occurrence, distribution, and character; of drilling and mining operations, and of the storage and transport of crude oil and its liquid products. Part IV. describes the manufacture of shale oils and of the various tars obtained as by-products. Part V. deals with asphalts. Part VI. with the natural mineral waxes. Part VII. with the working up of crude oils, their distillation, fractionation, and chemical treatment; the manufacture of paraffin wax and lubricating oil; "cracking" and hydrogenation processes; and refinery waste products. Part VIII. describes the characters and uses of petroleum products, and Part IX. gives some account of the methods of testing and standardising them.

As regards the origin of petroleum, in spite of much discussion and the voluminous literature to which the subject has given rise, we know nothing with certainty. The volcanic or inorganic theory, although advocated by such authorities as Humboldt, Berthelot, and Mendeléeff, is inconclusive, and there is an increasing body of evidence against it. On the other hand there are many objections to the assumption that petroleum has been produced from organic remains, although the geological evidence, at least in the case of certain oil-bearing districts, lends a certain measure of support to it. The question is fairly discussed by the author in the light

of the most recent contributions to it, and, on the whole, he is inclined to consider that the majority of crude oils are probably of vegetable origin, although he advances no surmise as to the mechanism of their formation.

One of the most important developments connected with the petroleum industry is the utilisation of the natural gas which is evolved in enormous quantities in certain oil-bearing regions. This utilisation has mainly occurred on the American continent owing to the circumstance that certain of the oil wells are not too remote from centres of population. Many towns in America are supplied with this gas at a very low cost. Much of the gas is consumed in the manufacture of so-called carbon-black, an extremely fine form of soot far superior to ordinary lamp black as a pigment and for the manufacture of printing-ink. It is calculated that one pound of carbon black suffices to print 2250 copies of a sixteen-page newspaper. Upwards of fifty million pounds of this material were produced in the United States in 1920, from thirty-nine operating plants in various States, mainly in West Virginia and Louisiana. Considerable quantities are used in the rubber tyre industry, for the manufacture of stove polishes, Chinese and Indian ink, paper manufacture, tarpaulins, etc. But even when the gas cannot be immediately utilised it is now liquefied and stored under pressure by modern compression and refrigerating plant, and can be transported.

Mr. Kewley is to be congratulated on the production of a valuable contribution to the literature of an industry which is pre-eminently characteristic of our own epoch.

### Unified Human History.

*A Short History of the World.* By H. G. Wells. Pp. xvi + 432. (London: Cassell and Co., Ltd., 1922.) 15s. net.

THIS is a new work covering the same ground as the "Outline of History" and in the same spirit, but re-written and better written, and correcting many of the faults of judgment and proportion which disfigured the earlier book. Mr. Wells has digested his material in the interval and writes now with ease and mastery. The arrangement and general division of the space is quite satisfactory, and the production and illustrations are excellent. It is a great feat, following so quickly on the labours of the "Outline," and all who are interested either in history, in education or in the social progress of the world as a whole, are under a deep debt of gratitude to Mr. Wells for carrying it out. Nothing has done so much to awaken the public to the social importance of history, and the readers of history to the unity of their subject. The books are a prodigy of industry and skill and in the realm of literature the

best thing we owe to the war. It was at a gathering of thinkers and social workers during the war that the idea of teaching world-history to all nations on a common plan was first mooted, and Mr. Wells responded to the appeal. His "Outline" has sold in hundreds of thousands, especially in the United States. It has provoked demands among working men to be taught history in that spirit; it has changed the outlook and the syllabuses of scores of teachers; it has helped to success other similar books such as the fascinating "Story of Mankind" by Van Loon, which has come over to us from America this autumn.

In view of all this, it is paltry and unworthy to dwell on minor defects or on differences of judgments, and still worse to condemn Mr. Wells because not being a "historian," he has done a work which "historians" ought to have done over and over again before.

It was probably this fact, that he was not a historian in that sense, immersed in the details of some special period or aspect of history, which, added to his own incomparable powers of reception, production, and imagination, enabled Mr. Wells to accomplish the feat. The freshness of his mind prompts him constantly to some interesting new view, some comparison especially of ancient and modern times, some wholesome challenge to accepted judgments; e.g. "It was not so much the Jews that made the Bible, as the Bible that made the Jews." "How important a century this sixth B.C. was in the history of humanity. For not only were these Greek philosophers beginning the research for clear ideas about the universe and man's place in it, and Isaiah carrying Jewish prophecy to its sublimest levels, but, as we shall tell later, Gautama Buddha was then teaching in India and Confucius and Lao Tse in China. From Athens to the Pacific the human mind was astir."

Even in the case of Rome, to which Mr. Wells still does less than justice, it is enlightening to have the comparison with our modern empire. "The Roman empire after all was a very primitive organisation; it did not educate, did not explain itself to its increasing multitudes of citizens, did not invite their co-operation in its decisions. There was no network of schools to ensure a common understanding, no distribution of news to sustain collective activity."

All such comparisons, whether of contemporary happenings or of earlier and later social states, are useful and inspiring and arise from the synoptic frame of mind which qualifies a man for such work as this. It is an antidote to the excessive criticism and tendency to pessimism which mark so much of our literature at the present time. But it needs to be based on a sound knowledge and appreciation of the historical fact, and it is naturally on this latter side that Mr. Wells is weaker. He does not estimate duly what Rome did for the world,

the greatness of her legal work, its continued progress, its permanence in the modern world. Nor does he allow for the constructive value of the medieval Church and Catholic doctrine. No word of Dante (or of Descartes) with a whole chapter for Charles V.! That is a blemish impossible to pass over. It goes with a general tendency in the book to lay stress rather on the externals and the picturesque figures in history than on the deeper, spiritual, or intellectual factors. Thus Archimedes and Hero appear but not Pythagoras, Stephenson and Watt but not Descartes and Leibniz, or even Newton. Science appears as the transformer of industry, the generator of steam-engines and steamships, but not as the knitter-up of men's minds, the new universal doctrine which replaces theological dogma. Even science as the healer and preventer of disease seems to find no place: there is no word of Hippocrates or Pasteur.

We know well how easy it is in reviewing such a book to draw up lists of inexcusable omissions. It would be ungrateful in this case, for Mr. Wells has given us so useful and attractive a gift and has worked so valiantly for the cause both of history and of science, and especially of science as coming into and modifying history. His answer, no doubt, to the last criticism would be that this was an introductory volume, and that therefore he avoided such matters as philosophy. But can one properly treat of religion without philosophy? And there are sympathetic chapters about Christ and Buddha. It would help his general cause, which is the salvation of mankind by education and unity, to lay more stress on the spiritual or intellectually constructive aspect of science and less on its mechanical applications. It is not the difficulties of posts and tariffs which will ultimately bring mankind together in harmonious progress: it will be a spiritual union of which knowledge and sympathy, science and law are co-operating factors, and may be traced growing, sometimes fitfully, and at various times and places, but never quite extinguished from the beginning of history till now. These should be the leading threads in any short sketch of human history as a whole, and it is because of their decisive contributions to those elements that Greece, Rome, Christianity, and modern times deserve a special place.

F. S. MARVIN.

### Naturalisation of Animals and Plants.

*The Naturalisation of Animals and Plants in New Zealand.* By the Hon. George M. Thomson. Pp. x + 607. (Cambridge: At the University Press, 1922.) 42s. net.

FROM those early days in the neolithic age when the nomad tribesman drove his domestic stock from the region of its creation to new areas, naturalisa-



tion of plants and animals has been a fact to be reckoned with in the evolution of faunas and of humanity. Even in countries where the introduced creatures belonged to groups identical with, or closely related to, members of the indigenous fauna, and where, on that account, a simple speeding-up of a process already in force might have been expected, the influence of naturalisation on fauna and flora has been profound. It is easy to imagine how much more intense that influence might be in countries where the new-comers belonged to orders of animal and plant life unrepresented in the native fauna and flora, and entered a free field unhampered by the checks which, in the course of ages, had created in the old country a tolerably stable balance of Nature. It is this unusual mingling of the faunas of distinct and widely different zoo-geographical regions that gives special significance to the events in Australia and New Zealand, and has made the attempts of the settlers there a by-word in the history of acclimatisation.

Another special interest attaches to these areas, however, and adds enormously to the value of this book. In the old countries, lying in the way of the migrations of palæolithic and neolithic man and his successors, introductions of plants and animals have taken place from time immemorial, with the result that, since the beginnings are lost to view, results can be only dimly envisaged; but in New Zealand, apart from a few prehistoric Polynesian introductions, almost every beginning has a date, and almost every stage of progress can be measured in terms of years.

Mr. Thomson has dealt with the unique opportunity that lay to his hand in the scientific spirit; he has been chary of broad generalisations, and he has been at endless pains to collect and verify information, much of which in a few years would otherwise have slipped from ken. Consequently his work must be regarded as a standard contribution to the history of acclimatisation.

The plan of the book is of the simplest: after a short introduction and historical review, it proceeds to consider each animal and plant introduced to New Zealand, whether or not it has become established, in its order in systematic classification. (The author has overlooked the fact that all his rodents are grouped under the heading "Carnivora.") The mass of material handled can be only roughly gauged by the fact that of mammals and birds alone, 48 of the former have been introduced, of which 25 have become truly feral, and of the latter, 24 out of 150 introduced species are now thoroughly established; while of plants, more than *six hundred species* have become "more or less truly wild."

It is impossible here to follow Mr. Thomson's cata-

logue of events; even the familiar stories of the ill-starred introductions of the rabbit and its enemies, and of the introduction of humble-bees to fertilise the introduced red clover, are filled with new and significant detail; but let us turn to some of the broad results of this century and a half's intense interference with Nature.

Great expectations were formed of the probability of seeing the development of new variations and of incipient new species; but fifty years of close observation lead the author to state that he is "aware of no definite permanent change in any introduced species" (p. 513). The statement does not exhaust the possibilities, however; first, because the time is short—the first animals were introduced in 1773, and most have been in the country for scarcely more than half a century; secondly, because changes are noticeable—red deer introduced from Forfarshire only fifty years ago, now carry, instead of a former limit of 12, up to 20 points on their antlers; and, thirdly, because the progeny of introduced animals has not been submitted to that minute examination and comparison of cranial and other characters on which racial distinctions are now based. Again, Darwin and Wallace both expected that the wholesale naturalisation of European plants would ultimately exterminate part of the native flora. The author sees no evidence of such a process: "The native vegetation can always hold its own against the introduced" (p. 528); "the struggle . . . will result in a limitation of the range of the native species rather than in their actual extermination" (p. 533). But is the conclusion not doubtful, or at any rate premature? In long-civilised countries, for example, Scotland, it has been shown that there are no bounds to the cumulative effect of man's influence, and that limitation of range is too often but a first step to ultimate, even if long-delayed, extinction.

Yet many changes have been observed. Introduced trout established new records in size, water-cress grew to a length of twelve to fourteen feet, "with stems as thick as a man's wrist," the common spear thistle formed thickets six to seven feet in height; even since 1868 nine species of birds have disappeared to a great extent or altogether, and many have been driven to the wildernesses; several species of fish have been exterminated by established introductions; habits have changed—many species have adopted introduced food plants, the Kea parrot supplements its fruit diet with the flesh of living sheep. On the whole, the introductions have done much more harm than good. Of all the birds introduced, the only one against which no complaint has ever been made is the hedge sparrow; but there must often be difficulty in assessing the balance of good and evil. In one place we are told

that "the evidence regarding the destruction of the native avifauna by stoats and weasels is very inconclusive" (p. 73), and in another that "these animals [weasels and other vermin] are largely responsible for the decrease in the numbers of native birds" (p. 89).

One conclusion, however, is manifest, that neither in New Zealand nor elsewhere should naturalisation of exotic animals be permitted, except with the consent of a properly constituted advisory committee containing a strong representation of biological science. Perhaps we can afford to smile at the enthusiasm of men who endeavoured to establish migratory birds, or brought from Britain the humble-bee, *Bombus terrestris* (now the commonest species in New Zealand), to fertilise the red clover, not knowing that its trunk was too short to reach the bottom of the clover flower; but we should not be subject to the vagaries of such as the New Zealand legislator who, when it was proposed to introduce half a dozen Venetian gondolas, to be placed on a lake in the public gardens of Nelson, protested against the extravagance and desired to import only a pair, "and then let Nature take its course."

JAMES RITCHIE.

### Boscovich and Modern Science.

*A Theory of Natural Philosophy.* Put forward and explained by Roger Joseph Boscovich. Latin-English edition. From the Text of the First Venetian edition published under the personal superintendence of the Author in 1763. With a short Life of Boscovich. Pp. xix+470. (Chicago and London: Open Court Publishing Co., 1922.) 63s. net.

IN the time of Boscovich the line of demarcation between the philosopher and the physicist or mathematician was much less clearly marked than it is to-day—perhaps it is better to say than it was a few years ago. It is therefore to be expected of a man of Boscovich's energy and versatility, living in the eighteenth century, that he should have explored the borderland of philosophy and science. The book before us contains the contribution of Boscovich to this domain—for us the most important work of his life. In it he appears to a modern as a philosopher rather than a man of science, interested largely in the search for and use of *a priori* arguments, but in close touch with the scientific theories and explanations of his day.

Whether this classification is right or wrong, the book is full of interest. Boscovich is sometimes claimed as the father of modern atomic theory, and this volume provides at any rate partial justification for the claim. For Boscovich shows with admirable clearness how many diverse phenomena in mechanics

and even in other branches of physics can be explained in a natural qualitative way on his hypothesis that matter consists of discrete points accelerated towards each other by a perfect definite law of suitable form. But from the modern point of view his work in this connexion is scarcely more interesting than the earlier work of Daniel Bernoulli, or the still earlier ideas of Hooke. To a mathematician perhaps the most interesting sections of the book are those in which Boscovich expounds the law of continuity, the doctrine of impenetrability, and their consequences. It is at once evident that his ideas of the properties of a continuum and of a progression, though of course not extensive, are invariably clear and accurate.

Other interesting passages are those in which Boscovich makes use of proofs by induction or criticises the inductive reasoning of others—for example, attempts to establish thus that matter must have continuous extension. He is always careful to explain why he believes his own inductive arguments to be valid when he makes them. In fact one may strongly suspect that his first instinct in all such cases is to take up a sound sceptical point of view, with perhaps a slight weakness for his own favourites. In this he is by no means unique, and in full agreement with a certain distinguished man of science of to-day who is reported to have defined scientific truth in conversation with a friend as "the theories which you and I believe, and I include you for courtesy."

Boscovich is firmly convinced of the underlying simplicity of all natural phenomena. The main thesis of his book is to show that it is conceivable that all the properties of matter might be explainable on the basis of his unique acceleration law. In a delightful passage (pp. 105-7) he attacks the multiplicity of forces used by the physicists of his day and the danger of concluding that Nature is complicated when it may only be that the mathematics is inadequate.

Both as a final example of the depth and range of his ideas and for its latter-day interest we must quote the following passage, in which he is discussing the form of his acceleration law. He has just assumed that the mutual acceleration of two of his points is always bounded except when the distance between them actually tends to zero. He proceeds: "In this case it is evident that, if a sufficiently great velocity can be given to any mass, it would pass through any other mass without any perturbation of its own parts, or of the parts of the other. For the forces have no continuous time in which to act and produce any finite sensible motion; since if this time is diminished immensely . . . the effect of the forces is also diminished immensely. We can illustrate the idea by the example of an iron ball, which is required to pass

across a plane, in which lie scattered in all positions a great number of magnetic masses possessed of considerable force. If the ball is not projected with a certain very great velocity . . . its motion will be checked by their attractions. But if the velocity is great enough, so that the actions of the magnetic forces only last for a sufficiently short interval of time, then it will certainly get through and beyond them, without suffering any sensible loss of velocity." Further evidence of his clarity of thought need scarcely be given.

In conclusion let us admit the great debt of gratitude which we owe for the production of this book to the translator, Mr. J. M. Child, and to the Government of the Kingdom of Serbs, Croats, and Slovenes who generously financed its publication.

### Our Bookshelf.

*Chelsea Porcelain.* By William King. Pp. xv + 135 + 70 plates. (London: Benn Bros., Ltd., 1922.) 75s. 6d. net.

It seems appropriate that this elaborate and sumptuously illustrated volume should proceed from an official of the ceramic department of the Victoria and Albert Museum, where an extensive and thoroughly representative collection of Chelsea porcelain is permanently displayed for the delectation of the public. Such a handbook of one section of the treasures housed in the museum, setting forth the story of their manufacture and the reasons or sentiments which inspired the decorations they bear, should bring many fresh visitors to the collections. It should stimulate the interest which each succeeding generation manifests in the doings of the potters and porcelain-makers of a past age, for they have proved themselves the unconscious historians of its social customs. It is impossible for any one, however limited his purview, to linger among these brilliant and fascinating objects without feeling a desire to know more of their history and how they came to be decorated as they are. Even to those who know little of historic styles in decorative art it must be obvious that whatever is native and English in these porcelains is interwoven with motives caught from the work of other countries than ours, Oriental as well as European, so that they provide even a casual observer with endless food for thought and research.

To-day, after a century and a half of change, it stirs our blood to examine such masterpieces of patient skill and elaboration, wrought in a beautiful but difficult material with an insufficient regard to time and cost, when an English factory tried conclusions with the state-aided establishments of Europe and won a well-deserved reputation for its courage and skill.

The gradual development of the Chelsea enterprise from its modest beginnings to the heyday of its success is traced with a wealth of detail drawn from the patient labours of many previous investigators, but its story is enriched by the knowledge which is only to be acquired from the constant handling and critical examination of

fine and authentic examples; so that, for many a long day, this volume is likely to remain a standard authority on its subject.

The numerous illustrations are remarkable for their variety and excellence. They cover the whole field of the porcelains made at the Chelsea factory, and, whether in colour or in half-tone, convey an excellent idea of the range and quality of the productions of that famous factory.

WILLIAM BURTON.

*Blood Transfusion.* By Dr. Geoffrey Keynes. (Oxford Medical Publications.) Pp. vii + 166. (London: Henry Frowde and Hodder and Stoughton, 1922.) 8s. 6d. net.

THE transference of blood from healthy persons to make up for deficiencies of quantity or quality in the sick has been proposed and occasionally practised for 300 years or more, but it is only within the last decade, and especially since the experience of the war, that this valuable therapeutic procedure has been put on a firm foundation and has come into common use. Dr. Keynes gives here an admirable account of our present knowledge of the theory and practice of transfusion. There is a most interesting historical account of the work of the pioneers, and it is curious to note that Higginson, in the middle of the nineteenth century, invented and used his syringe for this rather than its present purpose. The selection of blood donors is fully considered and a good description given of the different "blood groups" found in human beings—a topic of much wider importance than its immediate application to human therapy. In technique, the author's experience has led him to prefer the method of withdrawing the blood into a solution of sodium citrate to prevent clotting and then injecting a known amount at leisure into the recipient: anastomosis of the blood vessels of the two parties is difficult and uncertain.

In practice, the main usefulness of transfusion has been found in cases of hemorrhage and shock, in which, as might be expected, blood has proved of more value than salt solution or Bayliss's gum. It has given good, if generally transitory, results in pernicious anæmia and a few cases of severe bacterial infections, but there is no very clear evidence of its utility unless the patient has the definite indication of too small a blood volume or too little hæmoglobin.

There is a bibliography of more than 300 items and a good index. Complete as is the account from the point of view of the practical surgeon, some further consideration of the experimental work of Worm Müller and his successors would have been welcome. There is, too, no adequate discussion of what happens to the red cells in their new home, how long they last, and how they are destroyed.

A. E. B.

*The Voice Beautiful in Speech and Song: A Consideration of the Capabilities of the Vocal Cords and their Work in the Art of Tone Production.* By Ernest G. White. Third edition. Pp. viii + 166. (London: J. M. Dent and Sons, Ltd., 1922.) 7s. 6d. net.

THE author's devastating thesis, that the human voice is produced by the frontal sinuses and other cavities in the bones of the head, while "the vocal cords," which he regards as strings, "are not the seat of sound," is not supported by a particle of evidence. That so

misleading a book should not only find a publisher but also reach a third edition, is disquieting. A teacher should be teachable, and the serious student of phonation will find sound information as to the parts played by the sinuses and the glottal lips in the production of vocal tone in Mueshold's "Akustik und Mechanik des menschlichen Stimmorgans," 1913, which gives excellent laryngo-stroboscopic photographs of the mis-called "vocal cords" in action, confirming and supplementing Manuel Garcia's famous communication to the Royal Society in 1855 on the differing laryngeal mechanism for chest and falsetto registers. The kinematograph might do good service here.

The exhibition of a slow-motion film, such as that prepared by Prof. Panconcelli-Calzia and Dr. Hegener, of Hamburg, showing the lips of the glottis producing a definite note of chest register by periodically parting and meeting, parting and meeting, letting out as many tiny puffs of compressed air per second as there are double vibrations in the note sung (quite in agreement with what R. Willis, of Cambridge, wrote in 1828), and finally opening very wide for the singer to draw breath, would give in one minute a clearer idea of their double-reef action than pages of careful description may convey. Few misnomers, surely, have wrought so much pseudo-scientific havoc as Ferrein's *chordæ vocales* (1741). W. P.

*An Introduction to Psychology.* By S. S. Brierley. Pp. viii+152. (London: Methuen and Co., Ltd., 1921.) 5s. net.

UNLIKE many writers for non-professional students of psychology, the author of this work does not attempt to minimise the difficulty of the subject, nor does she seek to evade problematical conclusions by specious dogmatism. The book consists of two parts, the first dealing with the scope and method of psychology, and the second with some of the general problems of the subject. This latter part brings before the reader the fascinating but bewildering array of problems with which the modern psychologist is confronted. The reader is not left with the idea that having perused this book he knows everything about psychology, but he will feel that he has an excellent basis for continued study. The general plan is original, and while incorporating much of the work of such writers as James, McDougall, Freud, and Jung, yet it is much more than a mere compilation of the work of others. It will be of the greatest value not only to the beginner but also to any reader who wishes to get a clear survey of the state of psychology at the present time.

*Physiology and Biochemistry in Modern Medicine.* By Prof. J. J. R. MacLeod, assisted by Roy G. Pearce, A. C. Redfield, and N. B. Taylor, and by others. Fourth edition. Pp. xxxii+992. (London: H. Kimpton, 1922.) 42s. net.

THE first edition of this valuable text-book was reviewed at some length in NATURE of December 18, 1919 (vol. 104, p. 389), so that little remains to be said except to congratulate the author on the rapid appearance of successive editions. This fact is good evidence that the work fulfils a want. It will be remembered that it is especially directed to satisfy the requirements of the student and the practitioner of

medicine, so that it is natural to find certain branches of physiology more fully discussed than others. It is perhaps open to question whether, for the class of reader contemplated, the common practice of treating such questions as osmotic pressure and the colloidal state apart from that of the physiological processes in which they play an important part, is to be recommended. Prof. MacLeod has kept the book well up-to-date, and it has received valuable improvements and additions since the appearance of the first edition in 1919.

*The Conquest of the New Zealand Alps.* By Samuel Turner. Pp. 291. (London: T. Fisher Unwin, Ltd., 1922.) 21s. net.

MR. TURNER is a mountaineer of varied experience extending over a quarter of a century. His latest book describes six seasons' climbing in the New Zealand Alps, including ascents of Mounts Cook and Tasman, the two summits of the group. It is mainly a climber's record of difficulties and triumphs, but incidentally it contains much description of the peculiarities of the New Zealand Alps and the ice conditions encountered there. On the whole, the climbs in most cases were not of exceptional difficulty, but there seems to be a tendency for the snow slopes to hang steeper than in most countries. This is due possibly to the nature of the rock, but more likely is the outcome of the snow falling frequently and at relatively high temperatures, which gives it greater binding power. The snowfall at low altitudes even in midsummer is an additional difficulty.

*La Séparation Industrielle des Solides en Milieu Liquide.* Par Prof. Léonce Fabre. Pp. v+227. (Paris: G. Doin, 1922.) 16 francs.

THE treatment of filtration from the point of view of chemical engineering forms the principal subject of this book. The various types of apparatus, including immersion and rotary filters, are fully dealt with, and the auxiliary apparatus, including pumps, thickeners, and classifiers, are also described, and methods of decantation are considered. The book is up-to-date, and the numerous illustrations add considerably to its interest and value: it is a most useful contribution to the literature of chemical engineering. As is usual in French books, the absence of an index takes away practically half the value of a work of this kind. This may seem a small point to the author, but English and American readers of technical books will consider it a very serious defect.

*Seven Ages of Childhood.* By Ella L. Cabot. Pp. xxxiv+321. (London: Kegan Paul and Co., Ltd., 1921.) 12s. 6d. net.

MRS. CABOT divides the period from coming into the world to coming of age into seven sub-periods which she names the dependent age (0-3), the dramatic age (3-7), the angular age (7-11), the paradoxical age (12-14), the age of the gang or team (11-16), the age of romance (15-18), the age of problems (16-21). On all these she writes pleasantly and sympathetically. There may be little of striking originality in her pages; but there is a touch of serene wisdom which may perhaps be found more helpful.

### Letters to the Editor.

[The Editor does not hold himself responsible for opinions expressed by his correspondents. Neither can he undertake to return, or to correspond with the writers of, rejected manuscripts intended for this or any other part of NATURE. No notice is taken of anonymous communications.]

#### A Type of Ideal Electric Atoms.

THE *Philosophical Magazine* for December contains a long and interesting mathematical paper by R. Hargreaves, in which he explores possibilities of constructing self-sustaining orbital systems out of free massive positive ions combined with free negative electrons, held together by a rotation common to all. The solutions at which he arrives give a possible structure for an ideal atomic nucleus of the Rutherford type, namely, a revolving ring of alternate positive ions and negative electrons, with or without a positive ion at the centre or a number of ions lying along the central axis of the ring transverse to its plane. It is found that a limited number of structures of this type can subsist, stability requiring that the central charge shall be positive.

Analysis of the deformation of such a free ring by a field of electric or magnetic force yields striking results as regards the polarisations thereby produced, recalling cognate classical results obtained by Lord Kelvin and others long ago, relating to vortex rings in fluid. Around such a ring-nucleus outer electrons can describe orbits as satellites, either a few of them or many arranged in rings in the manner now familiar in illustrations of the outlying structure of atoms: their reactions on the ring-nucleus are analysed. So also are the reactions on the whole system of stray electrons or ions coming within its range from without, which may even combine with it in definite ways: interesting analogies to phenomena of ionisation and of emission of electrons come to light. The scale of magnitude of the system remains open to satisfy other conditions.

The author modestly disclaims authority to judge whether the properties he discovers have any substantial analogy with the radio-active and spectroscopic phenomena of actual atoms. But, apart from the mathematical interest, there can be no question that the result of such a systematic rigorous analysis of the dynamical behaviour of a definite group of free systems, proved to be possible and stable, is calculated to expand the range of ideas in this field of physical speculation, and so is well worth the labour it has entailed. The alternating arrangement of ions and electrons in the nuclear ring calls to mind recent theories in the very different domain of crystalline structure and conductance in metals, based on space-lattices in which metallic ions and electrons occur alternately.

J. L.

#### Cambridge and the Royal Commission.

KINDLY permit me to reply to the criticisms in NATURE of November 25, p. 689, on my article in the *Quarterly Review*. (1) I note with satisfaction that my critic admits that "many of those who do not share [my] fears will agree with [me]" on the importance of having the proposed grants "charged on the Consolidated Fund." My fears arise from (a) the declaration made to the Commission by the Labour Party that the "control of the Universities merely by statute assisted by occasional Royal Commissions has now definitely failed and that something in the nature of a continuous administrative control by the State must be undertaken," and (b) from the imperious demand that this control should be exercised "by

representatives of Trades Unions, Elementary School Teachers, Women's Organisations, County Councils, the Board of Education, etc." (Report, p. 72, *Q.R.*, pp. 350-351). Are my fears groundless in view of the fate which has befallen the Universities of France, Germany, and Holland, under State control?

(2) My critic tries to defend the proposal to hand over the control of all teaching and research to the Council, a political body, largely composed of men whose interests are in administration rather than in the advancement of knowledge, and seeks to justify this by the vague statement that "the electorate which chooses both bodies is the same," leaving out of sight the fact that the elections to the Council are almost wholly on very clearly defined party lines with little regard to educational questions. It is proposed to supersede the General Board of Studies (composed of representatives of the 14 Special Boards of Studies and 8 nominated by the Council chiefly from their own members) by a new Board of Studies and Research subordinate to the Council, to consist of 12: 6 appointed by the Council and 6 only by the whole body of University and College teachers. As the General Board has on it representatives of all the Special Boards the co-ordination of the various studies and a proper standard for the higher Doctorates can thus be, and is, well maintained. The bureaucrats hate the General Board because they cannot prevent the Special Boards from placing on it their leading men, no matter what their politics may be. The General Board is charged with being "unwieldy," and at the same time not wholly representative of all branches of study, and that "its co-ordinating functions seem to be impeded to some extent by the fact that it is largely composed of specialists." The animus shown against "specialists" gives the key.

My critic does not attempt to meet my statements that it is not "unwieldy" since it has the same number as the Oxford Council (23), that it does its work excellently, while the Council, when it interferes with education, deals badly with it and is slovenly in its routine business. If the General Board is "not wholly representative of all branches of study," then the new Board of 12 will be much less so, and the evil effects of such a Board are already felt in the new Board of Research set up by the Council to deal with applicants for the Ph.D.

(3) With regard to the disfranchisement of the Senate, my critic says that "In his criticism of detail Sir William Ridgeway is not happy. When he says 'The Cambridge Commissioners know perfectly well that it would not be easy to get fifty signatures to any appeal within a week,' the obvious answer is that Sir William Ridgeway knows perfectly well that in any issue of importance where an appeal to the Senate is likely, fifty signatures could be collected in the Senate-House from the defeated minority," etc. Here are my actual words: "It would not be easy to get fifty signatures to any appeal within a week, and to get those of one-third of the House of Residents within 14 days would be impossible in view of the further proposal that if a Grace passed by the House of Residents were rejected by the Senate, that Grace could be re-affirmed within two terms and become final." No one would think of getting up, or signing, an appeal to the Non-Residents to waste their time and money in coming to oppose a measure (nor if asked would they come) which even if defeated by the Senate would become law in two terms. As my critic has not dared to challenge any of my facts, his only resort was to impugn my honesty by garbling my statement, an attempt as futile as disingenuous. He repeats the charge that the control of the Senate is "capricious," because "its interven-

tion is made at the capricious decision of a body of resident conservatives who, through the Senate, wield a wholly disproportionate power on matters vitally affecting the well-being of the University." Yet he had just admitted that only thrice in twenty-five years has the Senate come up in force, and that only once did it outvote the resident majority. His picture of wicked conservatives "constantly" calling up non-residents to oppose progressive Radicals is just as devoid of fact as the assumption that Radicals are always progressive.

When, in 1910, a like charge was made against the Senate, I recited in the Senate-House a list of much-needed reforms and progressive measures (in all of which I was concerned), e.g. a proper audit and control of Departmental funds, the reform of the Press, the reform of the Fitzwilliam Museum, the founding of the Departments of Anthropology and of Architecture, etc., etc. (all of which had later to be carried out), and I charged to their faces the Radical leaders who then controlled the Council, with heading the obstruction to all these reforms. No one then or since has disputed my allegations. The suggestion that resident conservatives are an insignificant body is disproved by our important gains in the late elections to the Council (even without the much-needed secret ballot). My critic does not deny that the proposals of the Report respecting the powers of the Senate, the constitution of the Council and of the Board of Studies and Research go much further than the proposals made by the committee of younger graduates (men under 40) who represent the most advanced opinion among residents. They wish that the ultimate decision on statutes should rest with the Senate, and that the professoriate should keep its representation on the Council, and have some of the proposed new Board of Studies.

WILLIAM RIDGEWAY.

Flendyshe, Fen Ditton, Cambridge,  
December 2.

LEAVING on one side the more personal aspects of Sir William Ridgeway's letter—his zeal for progressive reforms and the disingenuousness of his critic—a reply may be made to one or two of the points raised by him. He is mistaken in saying that the committee of younger graduates (men under 40) represent the most advanced opinion among residents. They have not unfairly been nicknamed "The Cambridge Whigs." Even this body, however, has suggested that members of the General Board (or Board of Studies and Research) should be nominated by the Council and that the Board should be reduced in size by abandoning the direct representation of the Special Boards of Study. It is held by many, who are equally keen with Sir William Ridgeway on the independent development of educational policy in the University, that the best solution lies in a small Board akin to the present Board of Research Studies, well balanced between the different faculties and working in close co-operation with the Special Boards. As to the question whether an appeal against the House of Residents would ever be made under the Commission's scheme, the writer differs absolutely from Sir William Ridgeway. Differences of opinion are too acute, and the fighting spirit of both sides too strong, to allow certain proposals to pass without a stern contest at every possible point.

THE WRITER OF THE ARTICLE.

#### Gravity Variations.

MR. R. D. OLDHAM'S letter in NATURE of November 18, p. 665, makes the disquieting suggestion that the force of gravity at Dehra Dun may be subject to

fluctuations. The changes that he points out in the times of oscillation of the Indian pendulums can, however, be quite reasonably attributed to alterations in the lengths of the pendulums and errors of observation, and are not, in my opinion, so grave as to warrant a belief in anything more fundamental. As Mr. Oldham says, there is neither proof nor disproof of a change in gravity. But the discussion undoubtedly indicates a weak spot in the Indian operations, namely the connexion of Dehra Dun with Kew Observatory, which is the base station for this country. It rests on the results obtained with four pendulums swung at Kew and then transported to Dehra Dun and swung there. The pendulums have never been brought back to this country, so if they suffered any changes of length on the journey from Kew to Dehra Dun the value of  $g$  found at the latter place will be erroneous.

It would, of course, have been necessary to undertake a return journey long ago if no corroboration of the result of the first journey had been available. There was, however, the strong corroboration afforded by Hecker's observations in 1905, as mentioned by Mr. Oldham, and the valuable though less powerful evidence obtained by Alessio in 1906. Hecker's result was of special value because at Jalpaiguri his apparatus was set up alongside the Indian one and simultaneous observations were made using the same clock. Thus there was good reason to believe that the effects of fluctuations of temperature and variations in the clock's rate—the chief sources of uncertainty—would be the same on both sets of observations, and that therefore the check on the Dehra Dun value of  $g$  would be nearly as satisfactory as if Dr. Hecker's pendulums had been swung at Dehra Dun itself.

The links forming the connexion of Dehra Dun with the value of  $g$  determined at Potsdam are as follows:

Result.

Potsdam—Kew (Putnam, 1900)	
Kew—Dehra Dun (Indian operations, 1904)	979.063
Potsdam—Jalpaiguri (Hecker, 1905)	
Jalpaiguri—Dehra Dun (Indian, 1905)	979.065
Potsdam—Genoa	
Genoa—Bombay (Alessio, 1906)	
Bombay—Dehra Dun (Indian, 1904)	979.059

The probable error of each of these results may be estimated to be between  $\pm 0.003$  and  $\pm 0.005$ . The agreement between them is therefore better than the probable errors would have allowed us to anticipate.

Commander Alessio's observations in 1913-14, however, give a value of 979.079 for  $g$  at Dehra Dun, which differs from the above by nearly four times the probable error.

Alessio's observations were most carefully made with a strong equipment of eight pendulums, and carry great weight. They have not, so far as I am aware, been published in detail as yet, and it is not possible to form a final judgment on them; but in the article in the *Rivista Marittima* quoted by Mr. Oldham, there is a remark which may perhaps indicate a weak point. Commander Alessio says that the comparison of the times of oscillation of the pendulums at Genoa before and after the journey show that certain changes had taken place in the lengths of the individual pendulums, but that fortunately the length of the mean of the eight pendulums had remained absolutely unchanged. If the changes in the individual pendulums were large, and if they, or any of them, took place before the pendulums reached Dehra Dun, then the deduced value of  $g$  at Dehra Dun may be burdened with a considerable error.

Whatever opinion may be formed when the whole of the details of Commander Alessio's work are avail-

able for examination, it is clear that the Dehra Dun value of  $g$  should be strengthened by a new direct determination of the difference Kew—Dehra Dun.

This could be made by sending the Indian pendulums back to Kew for a further set of observations to be made there, or, if the use of Invar pendulums is contemplated, then the new set of pendulums could be employed for this purpose. It is imperative that the value of  $g$  at Dehra Dun should be established so thoroughly as to be unimpeachable.

G. P. LENOX-CONYNGHAM.

Trinity College, Cambridge,  
November 29.

THE remarks by Mr. Oldham in NATURE of November 18, p. 665, relating to a suggested variation in gravity, are of great interest. As a result of measurements of  $g$  at Melbourne in 1913, a doubt as to the invariability of  $g$  relative to that at Potsdam was forcibly borne to mind. The report (Gravity Observations, British Antarctic Expedition, 1910-1913) which gives the results of the Melbourne measurements, has been delayed in the press, but it is felt that there is some evidence in this case of a lack of constancy in the value of  $g$  relative to Potsdam.

The problem is discussed in greater detail from another point of view in the Glaciological Report (Wright and Priestley), which is due to appear shortly.

C. S. WRIGHT.

Wey Lodge, Portmore Park, Weybridge,  
November 20.

### Action of Cutting Tools.

IN the interesting letters by Mr. Mallock and Prof. Coker which have recently appeared in NATURE, some points of importance to the elucidation of the action of a tool when operating on materials have been raised.

Mr. Mallock appears to adhere to the view expressed in his paper of 1881 that the action is simply a phenomenon of shear. H. Tresca, however, two years after Mr. Mallock's paper showed in his classical and extensive "Mémoire sur le rabotage des métaux" (*Mémoires présentés par divers savants à l'Académie des Sciences de l'Institut de France*. Tome 27, No. 1,

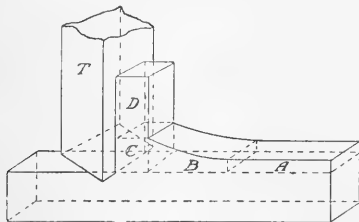

FIG. 1.

1883) that the phenomenon was primarily one of plastic flow. The periodic rupture of the chip which takes place is subsequent to the plastic flow stage and depends upon the nature of the material being operated upon, the angle the tool face presents to the advancing stream of material, and the velocity with which the material moves relative to the tool.

This stage of the action is complex and does not appear to be understood fully. The plastic flow stage, however, is comparatively simple.

In the diagram (Fig. 1) suppose that the tool T presents a plane face square to the advancing material. The portion A, which will ultimately form the chip

D, as it approaches the tool begins to flow in region B, which is Tresca's *zone d'activité*. The flow reaches a maximum in the region C from which the chip or jet of metal D emerges, and Tresca in the light of the results of his remarkable and historical investigations on the flow and deformation of solids likens the action to the flow of the metal through a tube of shape ABC with its orifice open horizontally at the top part of C. Since no change in the density takes place the product of the co-ordinates  $xy$  (where the origin is at the tool edge) of a point on any surface in B and C continuous with a horizontal plane in A must be constant, so that the traces of these surfaces in the sides and also the free edges of B are hyperbolas.

This zone B can be seen in some of the beautiful photographs of cutting tools published by Mr. J. F. Brooks (Proc. Inst. Mech. Engrs., 1905, p. 365) and more especially in the last photograph of Plate 10. If now vertical lines be scribed upon the sides, the state of affairs during flow of a material which does not rupture for large body-shifts, such as lead, is represented by Tresca in Fig. 2.

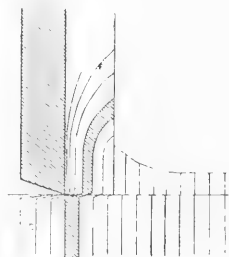

FIG. 2.

Here the maximum slide velocity is at the edge of the tool and in the horizontal plane through the edge. But one of the two important principles enunciated by Tresca is that during flow the maximum shear and maximum slide velocity are co-directional. We should therefore expect the material to rupture along this horizontal plane, and I think this can clearly be seen in Plate 11 of Brooks's photographs of the tool in action on mild steel.

Turning now to Prof. J. T. Nicolson's and Dempster Smith's experiments (*Engineer*, 1905, p. 358) and their diagram of the formation of a chip (Fig. 9), it may be seen that though the diagram is complicated by rupture phenomena and by the fact that the tool is acting on a wedge-shaped part of the forging, Tresca's representation of the plastic phenomena is well substantiated and the maximum shear is clearly seen in the initial stages.

The start of rupture along the horizontal plane is also clearly shown by Frederick Taylor in his presidential address before the American Society of Mechanical Engineers in 1906 (vol. 28), which is a monumental work on "The Art of Cutting Metals."

The same views are expressed by C. Codron in his extensive series of "Expériences sur le travail des machines-outils pour les métaux," published in the "Bulletin de la Société d'Encouragement pour l'Industrie Nationale," 1903-1905.

The second important principle enunciated by Tresca, namely, the maximum shear across any face of a small right six face is a constant =  $K$  (Tresca's plastic modulus), together with the one already mentioned, enabled Saint Venant to develop the general equations of plastico-dynamics. If the mathematicians

could concentrate on this subject, they would do industry a real service, for nearly all industrial operations such as punching, shearing, forging, milling, spinning, and, of course, the turning of metals, are plastic flow phenomena.

During experiments I carried out with heavy lathes in 1908 for the purpose of finding the most economical high-speed steel to use, I encountered some chips which were not only straight but actually presented concavity to the tool face, and I have one of these chips now. They were produced at very high speed on steel, and are mentioned in the discussion of a paper read before the Siemens' Stafford Engineering Society in 1908 (Proc., vol. 1, p. 93), on "The Plastic Deformation of Solids."

Brewster's beautiful photo-elastic method and Professor Coker's important applications of it enable the stresses during elastic strain of the tool and material in the region A to be computed, but Taylor, in the work cited, has shown how a tool should be forged and supported on the saddle to give it maximum life and maximum strength.

Unfortunately for engineering industry in this country, nearly all lathes are built with the vertical space between the upper surface of the tool rest and the line of centres far too small to enable Taylor's important conclusions to be put into practice.

ALAN POLLARD.

Imperial College of Science and Technology,  
November 29.

I GATHER from Mr. H. S. Rowell's letter published in NATURE for December 9 that, while interested in the subject of the flow of metals in shavings, he is not altogether familiar with the work that has already been done on the subject. In a comprehensive "Mémoire sur le rabotage des métaux" (which cannot be so well known as I have hitherto believed) published more than forty years ago, M. H. Tresca investigated the question of the curling of shavings, both experimentally and mathematically, the actual flow of the metal (expressed by a coefficient of *réduction*) being especially selected for study under very varied conditions. The following quotation indicates only part of the scope of the work: "Ces phénomènes sont aussi ceux dans lesquels, pour la première fois, les métaux les plus durs, tels que l'acier, le fer, se comportent en réalité comme le plomb, comme le savon, comme le cire, nous dirions presque comme les liquides, tant est complet le rapprochement que l'on doit faire entre les rides de nos différents copeaux et de véritables vagues de métal."

The memoir is published as one of the "Mémoires présentés par divers savants à l'Académie des Sciences de l'Institut de France," tome xxvii., 1883. Those familiar already with the beauty of the results obtained will pardon this effort to direct the attention of others to the work.

E. N. DA C. ANDRADE.

Artillery College, Woolwich,  
December 11.

### The Secondary Spectrum of Hydrogen.

SINCE the negatively charged hydrogen atom is known to exist, from work on positive rays, it seemed likely that Silberstein's particular solution of the three-body problem, applied by him to the case of neutral helium (*Astrophys. Jour.*, September 1922) should also be applicable in this case. Consequently the formula used by him was modified so as to apply to hydrogen (charge E instead of 2E, and hence N instead of  $\frac{1}{2}N$ ), and also a small but important correc-

tion was made to the value of N so as to take account of the fact that with two electrons instead of one, the correction to the mass of the electron for the finite mass of the nucleus is no longer the same.

It was assumed as a first approximation that the electrons would be arranged antipodally, and consequently the forces would be again central. So Curtis's value of N for hydrogen was corrected so as to apply to a nucleus of infinite mass:

$$N_{\infty} = N_{11} \left( 1 + \frac{m_1}{M} \right).$$

Frequencies were then calculated from the formula

$$\nu = N_{\infty} \left( \frac{1}{n_1^2} + \frac{1}{n_2^2} - \frac{1}{m_1^2} - \frac{1}{m_2^2} \right).$$

These frequencies were then sought for in the secondary spectrum of hydrogen; it is known that negatively charged atoms are to be found in hydrogen at fairly high pressures with intensity quite comparable with that of the positively charged atom ("Rays of Positive Electricity," p. 39). As a result it was found that 47 lines in the secondary spectrum agreed with the calculated values within an absolute error of one unit of frequency, taking integral values of  $n_2$  and  $m_1$  from 1 up to 10, and values of  $m_2$  from 1 to 15, while  $n_1$  was taken as 2 and 3.

This means that the frequencies can be looked on as a kind of "summation tone," being the sums of a Balmer or a Paschen frequency and a frequency in the infra-red.

It was also found that in several cases a physical similarity of behaviour was common to "series" of the lines grouped according to the  $m$ 's and  $n$ 's concerned, though this was not exclusively true. As a standard of reference for the observed frequencies the values obtained by Merton and Barratt (*Phil. Trans. A*, 1922, pp. 388-400) were employed.

As typical may be given the following:—

Formula.	Calculated.	Observed.	Error $\Delta\nu$ .	Character.
$\frac{3}{2}9$				
$\frac{3}{2}9$	16934.9	16934.51	+0.39	2 + CD
$\frac{3}{1}10$				
$\frac{3}{1}10$	17192.3	17192.14	+0.16	6 + CD + HP + He
$\frac{3}{1}12$				
$\frac{3}{1}12$	17527.6	17527.47	+0.13	3 + CD + HP ++ He
$\frac{3}{1}13$				
$\frac{3}{1}13$	17638.8	17639.89	-1.09	0 + CD ++ He
$\frac{6}{6}$				
$\frac{6}{6}$	18289.8	18288.26	+0.54	0
$\frac{6}{3}$				
$\frac{6}{3}$	19623.4	19622.74	+0.66	0 + He
$\frac{6}{10}$				
$\frac{6}{10}$	20240.7	20240.71	-0.01	3 + LP

In the foregoing table, the figures in the last column refer to intensity and the symbols to the physical properties of the lines as given by Merton and Barratt (*loc. cit.*).

It is hoped to complete these and similar calculations shortly and also to investigate the conditions under which these lines should be enhanced.

A. C. MENZIES.

Physics Laboratory, The University, Leeds,  
December 8.

### Science and the Empire.

THE admirable sentiments expressed in the leading article in NATURE of December 16 will undoubtedly be re-echoed by every scientific worker in the country. In stating, however, that the British Science Guild is the only organisation which exists to undertake the propaganda work "for the extension of an understanding of the influence of scientific research and its results," the very effective propaganda which is being carried out by scientific workers themselves under the



egis of the National Union of Scientific Workers is overlooked.

Of this body you say "it is a Trade Union affiliated, we believe, to the Labour Party, and it exists to secure suitable conditions of work and payment for its members rather than for the extension of natural knowledge." In that statement truth and error are intermingled. The National Union of Scientific Workers is a registered Trade Union; it registered as such when industrial and Civil Service joint councils on the Whitley plan were being set up and when it was announced that none but members of Trade Unions would be given representation on those bodies. The Employers' Federations registered as Trade Unions also and for the same reasons. But the National Union of Scientific Workers is not affiliated to the Labour Party or to any political party; it has no political funds, and it imposes no restraints upon the political activities of its members, three of whom stood for Parliament at the recent election, one in the Conservative interest and the other two as Labour candidates.

Again, while it is true that the National Union of Scientific Workers exists to secure suitable conditions of work and payment for its members—and all other scientific workers incidentally—it considers that the best way to do this is by raising the professional standard of scientific workers by improved training and education, and making them aware of their importance as citizens on one hand, and on the other, by pointing out to employers and captains of industry that it is an economy to employ the best scientific workers, to encourage research, and to assist the universities. In order to persuade private employers, corporations and governing bodies to deal justly with scientific staffs, it is true that the Union would be prepared to follow the methods employed by such bodies as the British Medical Association; but it believes with the British Science Guild that the attitude of the general public towards science is due to ignorance or apathy. Accordingly, it puts propaganda efforts, designed to cure these diseases, in the forefront of its programme, hoping thereby to increase the demand from industry and the State for the best scientific knowledge. It is ready to co-operate with any other body for this purpose, and to assist any political party with its advice on matters appertaining to science and scientific workers. It believes, however, that scientific workers themselves must be their own propagandists, and that the first step towards really effective action is unity in the profession of science.

A. G. CHURCH,  
General Secretary.

National Union of Scientific Workers,  
25 Victoria Street,  
Westminster, London, S.W.1,  
December 18.

[THE National Union of Scientific Workers is an occupational organisation; therefore its propaganda efforts, useful as they are, are naturally regarded by the public as arising from self-interest. The British Science Guild, on the other hand, requires no technical or other qualification for membership; and, as was pointed out in our article, it bears the same relation to scientific workers that the Navy League does to the Royal Navy. It seems to us that a body of this type, in which citizens engaged in many and diverse departments of national life are concerned, can afford much more effective and disinterested support of science than is possible by any group consisting of members of the profession alone. That was the main point of the article to which Major Church refers, and we see no reason to depart from it.—  
EDITOR, NATURE.]

### The Hermit-crab (*E. bernhardus*) and the Anemone (*C. (Sagartia) parasitica*).

NATURE of December 2, p. 735. I described observations and experiments on the common hermit-crab (*E. bernhardus*) with its messmates, the anemone (*C. (Sagartia) parasitica*) and the polychaete worm *Nereis fucata*. By the kindness of Mr. Hugh Main, it has been pointed out that the observations mentioned above with regard to the natural position of the anemone confirm those of J. Sinel (p. 39, "An Outline of the Natural History of our Shores," 1906). Sinel states that "the woodcuts that appear in many text-books—even our high-class ones—which represent this anemone and its congener, are in one respect incorrect. The anemone is always represented as upright—palm-tree like—on the top of its equipage, as if its chief object were display—or a ride. . . . I have invariably found the anemone affixed to the rear of the shell and in such a position that when the hermit is at a meal or even moving about, the margin of the tentacles just touch the ground, like some patent sweeping-machine. It, no doubt, finds this position a paying one."

Sinel's unique and fascinating book contains a fund of information hidden away in a popular description of natural history on the shore. It is plain that, owing probably to the popular character of the book, many naturalists have passed over important original observations described therein by Sinel, whose knowledge of the biology of the shore has probably never been equalled.

Sinel's observations were previously unknown to me, but the agreement in the two sets of independent observations is valuable in opposing a traditional error, and will be sufficient to establish the correctness of the interpretations; the natural position of the anemone on the hermit-crab was clearly first shown by Sinel.

J. H. ORTON.

Marine Biological Laboratory,  
Plymouth, December 13.

### Winter Thunderstorms.

MAY I through your columns again ask for reports of thunderstorms occurring in the British Islands between January 1 and March 31? With the help of your readers and of observers of the British Rainfall Organization I was able to collect a mass of information on winter thunderstorms for 1916, 1917, 1918, and 1920, from which it appears that on more than 40 per cent. of the days in question, thunderstorms occurred somewhere in the British Islands. In collaboration with the Meteorological Office I propose to collect information again. The chief points to be noticed are the times at which the storms occur, and especially the times of passage of such storms as pass overhead; whether a severe storm or whether there are only one or two flashes of lightning or only one or two claps of thunder; whether there is a change of wind or a drop of temperature with the storm; whether there is rain, hail, or snow; in the case of lightning seen at night the direction in which it occurs; and any other information the observer thinks of interest. Reports are wanted especially from the west and north of Scotland, and from the south-west, west, and north-west of Ireland, but any information however slight from any district in the British Islands will be of great use to the investigation. Reports should be sent by postcard or letter to my address (not to the Meteorological Office).

C. J. P. CAVE.

Stoner Hill, Petersfield, December 20.

### The Corrosion of Ferrous Metals.

IN 1916 a committee was formed by the Institution of Civil Engineers under the chairmanship of the late Sir William Matthews, with sixteen members to investigate the "Deterioration of Structures exposed to Sea Action." The project was, in the first instance, submitted to the Department of Scientific and Industrial Research, which gave it every encouragement and promised the committee substantial financial assistance which has already amounted to several thousand pounds.

An important part of the committee's investigations is that connected with the corrosion of iron and steel structures exposed to sea action. In an exceptionally well-illustrated paper, read before the Institution of Civil Engineers on April 4, 1922, Sir Robert Hadfield

work. In general the specimens were allowed to retain their outer skin of oxide, normally present on the rolled or cast metals; in two cases, however, additional specimens were prepared from which the skin was removed by grinding, in order to obtain information as to the effect of oxide layers upon the corrodibility of the metal.

Specimens of all the metals were subjected to various mechanical tests, such as the Izod and Frémont shock tests, and the Brinell hardness test. Tensile tests were carried out on bars cut in the longitudinal direction. Save in the case of the cast irons the bars were marked at regular intervals along their lengths, and, after pulling, their elongations from point to point were carefully determined. This was done in

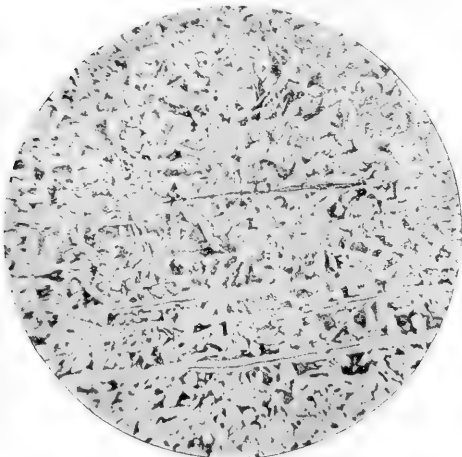

FIG. 1.—Mild steel (with 0.7 per cent. manganese).  
Longitudinal section  $\times 100$  (untreated).

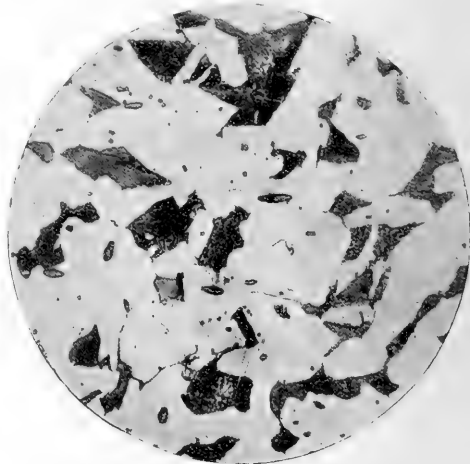

FIG. 2.—Mild steel (with 0.7 per cent. manganese).  
Transverse section  $\times 600$  (untreated).

gives a detailed account of the progress of the work down to that date.

The committee decided to expose fourteen types of ferrous material to sea action in various parts of the world and to determine by quantitative measurement their relative powers of resistance towards corrosion. The metals comprised "Armco" iron, Swedish charcoal and wrought irons, four types of carbon steel, cupriferos, nickel and stainless steels, and two samples of cast iron, cold and hot blast respectively. With the exception of the cast irons, the various metals were prepared in the form of rolled plates measuring 24 inches in length, 3 inches in breadth and 0.5 inch in thickness. The cast irons were of like dimensions, and were prepared by casting in the ordinary way. No further heat treatment was accorded the metals, for the committee considered that the tests would be of a more practical character if carried out with the metals in a condition resembling as closely as possible that obtaining in constructive

order to ascertain the effect of strain upon the corrodibility of the metal, the intention being to cut small test pieces from different parts of the strained bars and subject them to laboratory corrosion.

A duplicate set of tensile test bars, machined ready for testing, was prepared for immersion in that condition in the sea at Plymouth. After a prolonged exposure they will be removed and examined with the view of determining whether or not the mechanical qualities of the material are impaired. Very little work has been carried out on this aspect of the subject and the results obtained should prove of particular interest and value.

In addition to the foregoing, one bar of each material, excepting the cast-iron specimens, was suitably heat-treated in order to obtain test-data representing the physical properties of the materials under optimum conditions. The results obtained are detailed in the Appendix to Sir Robert Hadfield's paper and illustrate in a striking manner the enormous superiority in every

way of the heat-treated over the untreated metal. One illustration will suffice. In the case of mild steel, containing 0.25 per cent. carbon and 0.7 per cent. manganese, the yield point was raised by the heat treatment from 22.2 to 30.5 tons per square inch; the maximum stress from 33.5 to 42.8 tons; while the Brinell Ball Hardness Numbers rose from 145 to 197.

Needless to say, all the metals have been subjected to careful chemical analysis, and both the treated and untreated specimens have been studied photomicrographically, horizontal and longitudinal sections having been prepared of all the metals save the cast irons. This was rendered desirable in view of the fact that all the wrought irons and steels had been rolled. The longitudinal sections were taken at 100 diameters magnification, this being regarded as par-

better shock test results obtained with the treated material. It is calculated that in one of the mild steel specimens the number of grains per square inch is 820,000, while, when heat-treated, including quenching, the ferrite grains number about 5 million per square inch. This gives an idea of the closeness of the structure and the greater homogeneity produced by suitable heat treatment.

The necessary bars having been prepared, the committee were now faced with numerous problems connected with their despatch to various parts of the world, namely to Plymouth, Auckland, Colombo, and Halifax (Canada). One of the most difficult of these was the method of marking the bars. In view of the possibility in some instances of very severe corrosion, there was a distinct probability that any ordinary marking would be obliterated.



FIG. 3.—Mild steel (with 0.7 per cent. manganese). Longitudinal section  $\times 100$  (treated 900° water : 700° water).



FIG. 4.—Mild Steel (with 0.7 per cent. manganese). Transverse section  $\times 600$  (treated 900° water : 700° water).

ticularly suitable for examining the elongation of crystal grains due to rolling; the transverse sections were photographed at 600 diameters. Fifty-four beautiful reproductions of the photomicrographs are given in the paper, and four of these are reproduced in these columns through the courtesy of the Institution of Civil Engineers.

It is to be anticipated that the microstructure of the metals will play an important part in their powers of resistance to corrosion. Correlation of the micrographs and mechanical tests reveals several interesting features. In so far as the wrought irons are concerned, the heat treatment, by reducing the grain size, distinctly improves the shock test figures. The effect of heat treatment on the carbon steels has been, in the main, in the direction of preventing the marked separation of ferrite and pearlite, such as exists in the bars as rolled, and thus to produce a more homogeneous structure. This is well illustrated in the accompanying photographs.

This serves, in a large measure, to account for the

ated. It was intended that, when exposed to corroding influences, the two ends of the bars should be firmly embedded in concrete in a special frame erected for the purpose. Although a precise record would be kept of the position of each specimen in the frame, which would serve as some protection against mixing, there was the further danger that badly corroded bars might fall out of place and their identity be lost. The difficulty was eventually overcome by an ingenious system suggested by Mr. Maurice F. Wilson, a member of the committee, and now the chairman. The method consists in having one, two, or three holes drilled through the plates at both ends where they will be preserved by the enveloping layers of concrete. The holes are drilled in different positions; those at one end give what is termed the "classification letter" and indicate the type of metal, whether, for example, it is Swedish iron or cupriferous steel. At the opposite end the holes indicate the number of the bar.

In order to determine the effect of strain and of contact of dissimilar metals a few bars were bent at

right angles, others were fitted with ordinary rivets and bolts, while others were bolted one to the other. When all the bars had been carefully weighed they were packed in tin-lined cases and despatched to their respective destinations. The committee arranged that, at each place, one set of bars should be completely immersed in sea water; one immersed at half tide level, thereby becoming alternately wet and dry; and one set should be exposed to the sea air only.

When this comprehensive piece of research work is completed, the results should be of the greatest value not only to engineers but to all concerned in the use of ferrous metals.

Sir Robert Hadfield also gives an interesting account of the employment by the Admiralty of stainless steel during the war. Considerable difficulty had been experienced in consequence of the rapid corrosion of the diaphragms used in connexion with submarine hydrophones, which were put out of service in a comparatively short time. Messrs. Hadfield submitted experimental diaphragms of steel containing about 36 per cent. of nickel, and others of steel with a 12 to 14 per cent. chromium content. The latter alloy, the so-called "stainless steel," quickly proved its superiority, and was finally employed for the hydrophones. Although the nickel steel was very resistant to corrosion, its acoustic properties were not so good. These depend not only on the hardness of the metal but also upon its elastic limit, in both of which points the chromium steel was the superior. The diaphragms were placed in the hull of the submarine several feet below the water line, and it was noticed that although the surrounding plates of ordinary steel were soon covered with barnacles the chromium steel was entirely free. One of the diaphragms, after having been immersed in sea water under service conditions for

six months was found to have undergone practically no alteration. A small film of a dark-brown deposit was noticed patchwise here and there on the surface, but this was easily rubbed away with the finger, revealing the bright metal beneath.

One diaphragm did manifest local corrosion, and a photomicrographic examination revealed a coarse grain due, in all probability, to over-heating. A portion was suitably heat-treated and restored to a normal condition, after which it showed the usual full resistance to corrosion.

As this chromium steel is one of the metals employed by the Corrosion Committee in their programme of tests, it will be particularly interesting, in view of the foregoing results, to see how this metal behaves.

In conclusion Sir Robert Hadfield very rightly directs attention to the economic importance of the problems of corrosion. Accurate statistics on the subject are, for obvious reasons, unobtainable, but Sir Robert estimates that the annual cost of wastage due to rusting is probably well over 700 million pounds sterling, this sum including an estimate for the cost of galvanising the metal, and allowance being made for painting, sheathing, etc., all of which processes would usually be unnecessary if the metal were not so prone to oxidise.

One feature of this estimate deserves special attention. The amount of the annual production of iron and steel by no means represents an equal increase in the world's stock of these materials. The quantity swallowed up merely in replacing wastage is enormous. We unite with the author in the hope that his memoir "will arouse still more attention than the subject has received in the past, and will create greater interest in the production of alloy steels, which have the capacity of resisting corrosion, if not entirely, at any rate to a much greater extent." J. N. F.

### The American Museum of Natural History.

THANKS to the ideals of its president, the enthusiasm of its staff, and the abundant illustrations, the reports of the American Museum of Natural History are always interesting reading, and that for 1921 forms no exception. Indeed the president, Prof. H. F. Osborn, lays particular stress on this report, and he has reissued certain pages of it in a neatly bound booklet under the title of "The American Museum Ideal." That ideal he expresses in the words of Francis Bacon: "a model of universal nature made private. . . . A goodly huge cabinet, wherein whatsoever the hand of man by exquisite art or engine hath made rare in stuff, form, or motion; whatsoever singularity, chance, and the shuffle of things hath produced; whatsoever nature hath wrought in things that want life and may be kept, shall be sorted and included."

In short, the American Museum is become a world museum, and to that end it is sending out its explorers all over the world to gather and compare both for the benefit of Americans and for the benefit of every country which they may visit. Acknowledgment is made of the cordial co-operation which the American Museum receives from the Governments and scientific institutions of all those countries, while at home,

thanks to the large development of the educational side of its work, the museum continues to enjoy strong support from the city government. By the latter at the end of last year the sum of 1,500,000 dollars was unanimously voted for the erection of two new sections of the building as originally planned in 1875. There is also under consideration, as previously noticed in NATURE, a special school service building to be devoted exclusively to school education in all its grades.

Prof. Osborn's ideal, however, goes far beyond this. He says, "It is evident that astronomy will be the central feature of our plans, because all the processes of earth's history and all the processes of life centre around original astronomic causes." Plans for an astronomical hall have already been drawn up and published, and have been confirmed by the trustees. All that is wanted is the money. It is estimated that the buildings when finished will cost not less than 9,000,000 dollars, and Prof. Osborn calls for a new general endowment of 2,000,000 dollars. This latter, he says, will not only restore the museum to its full-time efficiency, but will enable it to prepare to keep its promise to the city government; and when its Asiatic and Oceanic sections are completed the museum will be able to fill them with the specimens now in store, including many

large groups already prepared and others awaiting preparation.

The large amount of space, and consequently money, that is required is partly due to the plan on which the American Museum of Natural History is arranged. Our own Natural History Museum has its exhibited collections arranged on a systematic or classificatory basis, but in the American Museum the basis is faunistic or geographical, and an even more serious attempt is made to display the animals in associated groups and under their natural conditions. One of the most striking exhibits illustrated in the present report is an African elephant group (Fig. 1) opened to the public during the past year. This includes a male, a female,

nearly five months, while studies were conducted upon them. The extinct vertebrates form an important section of the American Museum, and reference is made to many new reconstructions and exhibits. A complete series illustrating the evolution of the horse is being prepared. This section of the report is illustrated by a photograph of Erwin S. Christman at work upon the model of *Brontotherium*. We regret to read that Mr. Christman, who had been connected with the department from boyhood as draughtsman, artist, and sculptor, died on November 27, 1921. Another illustration represents a vigorous wall-painting, by Charles R. Knight, of the vertebrates found in the asphalt deposit at Rancho La Brea, and includes the

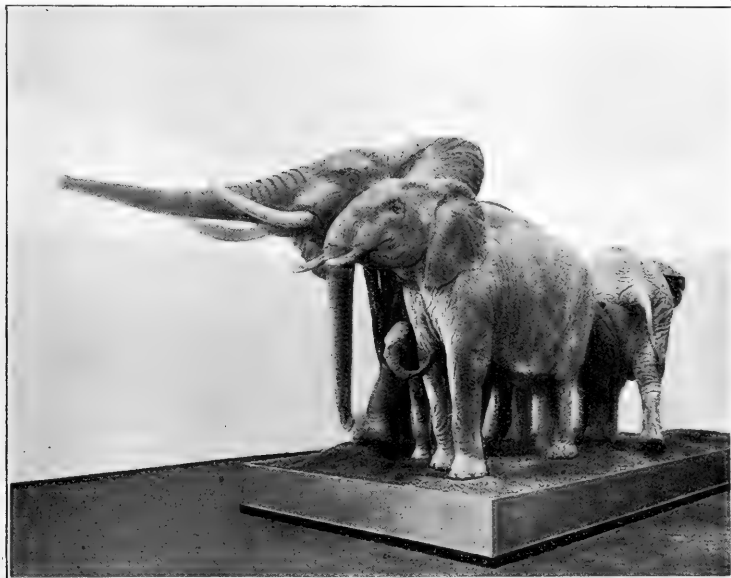

FIG. 1.—African elephant group in the American Museum of Natural History.  
(From a photograph kindly supplied by the Director.)

a young one, and a baby elephant, each in a different and characteristic position, and all together forming an impressive assemblage. This is the result of eleven years work by Mr. Carl E. Akeley, who went to Africa in 1909 to collect the material, and has since been developing and putting into effect a new method of mounting. No sooner was this finished than Mr. Akeley again left for Africa, where he has secured five fine specimens of the gorilla from the Lake Kivu District of the Belgian Congo. Another interesting exhibit consists of models of the marsupial frog of North America, *Ascaphus*, a primitive member of the *Discoglossidae*. This frog lives only at high altitudes among the Olympics and other western mountains. A number of specimens were sent alive to the museum by shipping them in a device allowing water to drip continually upon them. They were thus kept alive

sabre-tooth tiger, ground sloth, Columbian mammoth, and an extinct vulture.

Space does not allow us to comment on the very interesting reports from all the other sections of the museum, but we may remind our readers that the building serves as a centre for a large number of societies. So many as forty-three are mentioned as having held meetings, exhibits, or lectures at the museum during 1921. In addition to these the museum was the headquarters of the second International Congress on Eugenics, which Prof. Osborn considers to be the most important scientific meeting ever held in the museum. It was attended by leading eugenists from all parts of the world, and a special exhibit of genetics and racial heredity was prepared for it. Many members of the congress visited the museum to study this exhibit, and it is satisfactory to learn that

the newspaper press of the United States ended by according to the work of the meeting serious and satisfactory treatment. We commend this report to any one who wishes to learn in a pleasant and easy

manner of the extensive and varied work that is carried out by a modern museum, and to those museum curators who may desire inspiration in their daily labours.

### Presentation to Sir Edward Sharpey Schafer, F.R.S.

RATHER more than a year ago the suggestion was made that the Edinburgh meeting of the British Association would form a fitting occasion for the presentation to Sir Edward Sharpey Schafer of some token of their esteem from his present and past demonstrators and fellow research workers in London and Edinburgh. As so many of those who had been trained under Sir Edward now occupy posts in distant lands it was found impossible to make the necessary arrangements for the presentation at that early date.

Prof. Halliburton, however, made a statement at one of the largely-attended meetings of the Physiology Section of the Association, expressing the desire of all who had been associated with their old master in the prosecution of physiological research to present him with some mark of their esteem and affection, and indicated the form it would probably take.

Finally, it was arranged that the presentation should take the form of a full-sized plaque (Fig. 1), and that a medal replica should be presented to each of the many subscribers. The medal shows in bold relief the head and shoulders of Sir Edward, and bears on the reverse the inscription:—

Sodali bene merito  
Sodales bene volentes  
MCMXXII

The work was entrusted to Mr. C. d'O. Pilkington Jackson, A.R.B.A., sculptor, and has been carried out in an eminently satisfactory way. It is most artistic

and, moreover, an excellent portrait. The large bronze plaque from which the medal was reduced has been mounted on stone, with the inscription underneath it (Fig. 1). Sir Edward feels that it should eventually come to the University of Edinburgh, but at present it remains in the sculptor's studio as he wishes to exhibit it at the Royal Scottish Academy.

The large list of subscribers includes many of the leaders in physiology and other branches of medical science in this and other lands, a few of whom may be named—Bayliss, Rose Bradford, Halliburton, L. Hill, MacWilliam, Mott, Starling, in this country; and Hunter and Tait (Canada), Jolly (S. Africa), Malcolm and Mackenzie (New Zealand), Addis and S. Simpson (U.S.A.), Row (India), Itagaki and others (Japan). Among the original subscribers were two of great distinction who have unfortunately passed away—A. D. Waller and Benjamin Moore.

The recognition of Sir Edward Sharpey Schafer's invaluable services to physiology by those who have worked with him in the laboratory is a matter for sincere congratulation in which all who have the interests of the development of medical science at heart will join. All

will unite in expressing the hope that he has still before him many years in which he will continue his life-work.



FIG. 1. [Photo by Drummond Young.]

### Obituary.

F. B. BRYANT.

WE regret to record the death, on November 28, at the age of sixty-three, of Mr. Frederick Beadon Bryant, formerly Inspector-General of Forests to the Government of India. Mr. Bryant received his professional training at Nancy, joined the Indian Forest

Service in 1881, and was posted to the North-West Provinces and Oudh. Some of the earlier years of his service were spent in the preparation of working plans for the important sub-Himalayan forests lying between the Ganges and the Sarda rivers. This early training, together with some years of successful executive work in his province, marked him out subsequently for the

post of Assistant Inspector-General of Forests and Superintendent of Forest Working Plans, which he held for three years from 1896. After holding successively the posts of Conservator of Forests in the Punjab and Burma and Chief Conservator of Forests in Burma, he became Inspector-General of Forests to the Government of India, an appointment which he held from 1908 till 1913, when he retired from the service of Government. Mr. Bryant succeeded to this post at an important period in the history of his department. The Forest Research Institute at Dehra Dun had been established two years previously on the initiative of his predecessor, Mr. (now Sir Sainthill) Eardley-Wilmot. It fell to Mr. Bryant to guide the destinies of the Institute in its earlier years, and his handling of this task was marked by sound common sense and careful judgment. A man of cheerful personality, he made a popular chief, and enjoyed to an unusual extent the goodwill of his department. In recognition of his services to Government he was awarded the C.S.I. in 1911. He is survived by a widow and grown-up family, to whom we extend our sympathy. He had the misfortune to lose one of his sons on active service during the war.

M. E. BOUTY, professor of experimental physics at the Sorbonne and member of the Academy of Sciences,

died in Paris on November 5 in his seventy-seventh year. To the present generation of physicists in this country he was probably best known as the editor of the *Journal de Physique* and of the *Annales de Physique*, but to those of thirty or forty years ago he was the joint author of a text-book on physics much appreciated by all who wished to keep themselves up-to-date—the “Cours de physique de l'École Polytechnique” and its supplements. His principal published researches deal with problems connected with the passage of electricity through liquids and gases, but these memoirs by no means represent the whole of his work in the field of research. He succeeded in building up a school of research at the Sorbonne, and much work published by his pupils owed its inspiration to Prof. Bouty.

THE death, on December 10, is announced of Mr. Edward Degen, sometime of the staff of the British Museum and the Melbourne Museum. Mr. Degen was born in Basle in March 1852, and was educated in Basle and Paris. He travelled extensively and collected zoological material in West Africa, Uganda, Abyssinia, and Sakhalin. He was an expert taxidermist and had paid considerable attention to the moulting of birds, and to vertebrates generally. He was a Swiss and a citizen of Basle.

### Current Topics and Events.

IT is stated by the Paris correspondent of the *Times* that the centenary of Pasteur was celebrated officially during the afternoon of December 26 at the Academy of Medicine. The French Minister for Health, M. Paul Strauss, was present, and a number of eminent medical men spoke on Pasteur's life and work. The Under-Secretary of Posts and Telegraphs has approved a design, showing a profile of Pasteur's head, for a special fifty-centimes postage stamp to be issued during the coming centenary celebrations.

It may be remembered that, early in the present year, a proposal to prohibit the teaching of evolution in the schools of the State of Kentucky failed to pass the State legislature by one vote. In an article which appeared in *NATURE* of May 27 (vol. 109, p. 669), the opinion was expressed that further agitation with the same object might be looked for in the near future. That this apprehension was but too well founded appears by the fact that a “State-wide meeting of protestant ministers” in Minnesota has lately passed resolutions demanding that “the State shall prove its impartiality toward its citizens by dispensing with a subject (*i.e.* evolution) that is utterly divisive [*sic*]; and is, in the judgment of thousands of its taxpayers, utterly false.” A reason given for this remarkable action is that “this hypothesis . . . has increasingly shown itself to be a foe to the Christian faith, denying as it does the veracity of the Scriptures.” Such attempts at suppression are completely out-of-date, and the importation of religious intolerance into the question cannot but make the judicious grieve. The Minnesota meeting was perhaps not aware that the Catholic University of Louvain sent a special representative to the Darwin celebration at Cambridge.

YET another appeal has reached us on behalf of the famine-stricken people of Russia, this time from Dr. Nansen's committee by way of the Medical Aid Committee for Sufferers from the Russian Famine. It is addressed primarily to medical men, and, following out, apparently, the principle we have suggested in previous comments on these appeals, of approaching each group or profession on behalf of its co-workers in Russia, it is mainly for the assistance of medical men in Russia. It is stated that the latter, amid thousands of sick and starving people, are helpless for the lack of drugs and medical stores, and medical men here are asked to press for the formation of an international committee on medical relief to fight the effects of the famine. Men of science are needed to attack the sanitary and biological problems with which Russia and, through her, the whole of Europe are confronted. In the meanwhile supplies of medical and other stores will enable Russian doctors to struggle on with their task. Gifts in kind should be forwarded to the Secretary, Medical Aid Committee, 68 Lincoln's Inn Fields, W.C.2; contributions in money to the committee's treasurer at the London Joint City and Midland Bank, 6 Chancery Lane, W.C.2.

THE *Library Journal* for November 1 contains an article by Mr. E. C. Richardson, director of Princeton University Library, entitled “International Co-operation in Intellectual Work.” Mr. Richardson refers to the recent appointment by the League of Nations of a Committee on Intellectual Co-operation, and writes with appreciation of the practical utility of three enterprises which this committee will necessarily take into consideration. Mr. Richardson

was present, as an observer, at the Brussels meeting of August 20-22 to consider the future of the great bibliographical undertaking carried on for so many years by M. Lafontaine and M. Paul Otlet. He gives an outline of what he saw at the Palais Mondial at Brussels, where a portion of the former exhibition building is devoted to international co-operation. The building contains not only libraries and card catalogues, but also a permanent exhibition of the activities of all nations and an International Summer University. MM. Lafontaine and Otlet have for years superintended this work, sustained by their zeal, without drawing salaries. Mr. Richardson also attended the Convention of the International Catalogue of Scientific Literature held at Brussels on July 22 and 24. Of this meeting he writes: "Not only were there nine or ten nations represented by official representatives, but several of these showed a very vigorous interest and a disposition to continue contributions and to assist in paying the accumulated debt." Mr. Richardson also visited the Concilium Bibliographicum at Zurich. With the aid of funds secured for the purpose by the American Research Bureau, the work of the Concilium, which had been in abeyance since the death of Dr. Field, has been taken up again vigorously by Dr. Kellogg and the new director, Dr. Strohl. It is expected that printing will be resumed next July. Mr. Richardson believes that, with these enterprises in bibliography in existence, a "Committee on Intellectual Co-operation" should be able to secure that, by a proper division of labour, the bibliography of science should be well and completely executed.

DR. SALAMAN'S address to the Potato Conference at Ormskirk on November 2, which is published in the *Gardeners' Chronicle* for November 25, should prove of permanent value to horticulture, as while pointing out a present abuse it indicates at the same time that the remedy is ready to hand. Dr. Salaman dealt in vigorous language with the habit of seedsmen of listing the same variety of potato under different synonyms, frequently giving different descriptions to the variety upon its successive appearances, and often quoting it at different prices! The horticultural world is obviously concerned with the effect of the practice in commercial horticulture, but the scientific student of horticulture has to remember this ever-present source of error when he has to rely upon commercial firms for the supply of material in the form of cultivated plants for study or experiment. Fortunately the careful work now in progress at various plant-breeding stations throughout Great Britain, a work which is entirely disinterested from the commercial side of horticulture, is making it continually more possible to check the accuracy of popularly named varieties, not only of potatoes, but also of fruit stocks and scions, cereals, etc. Such work must precede any careful study of such a problem as the behaviour of a variety under continuous vegetative propagation, and bodies like the Synonym Committee of the National Institute of Agricultural Botany, of which Dr. Salaman is chairman, are rendering considerable service to science as well as to horticulture.

In the Journal of the Washington Academy of Sciences (vol. 12, No. 15), Mr. T. A. Jagger makes a plea for geophysical and geochemical observatories. Instruments of precise measurement need to be applied to the problems of geology. A record of the changes, for example, in a river system or mountain range, is essential if the processes involved are to be understood and given their due weight in the evolution of the earth's surface features. Geological science is lacking in measured facts of change within human time. The nature of changes may be gauged from temporary expeditions to different localities, but quantitative data can be obtained only by permanent observatories. The expedition method of study is never free from the reconnaissance element, and unexpected phenomena call for special instruments not included in the equipment. Moreover, there are seasonal and cyclic variations which an expedition misses. Mr. Jagger cites his own experiences at the Hawaiian volcanic observatory as an illustration of how continuous measurement may reveal rhythmic recurrences. He dwells on the nature of the work which might be done by river and mountain observatories. A glacier observatory would be equally valuable.

It is probable that the most important development of the cinematograph lies in its application to natural phenomena. To be able to make a leisured scrutiny of occurrences so momentary that the eye fails to hold them, is an inestimable gain. Appreciating the importance of such moving pictures, the Selborne Society has recently issued a list of cinematograph lectures ("Cinologues") and films which, under arrangements made with leading film companies, can be hired on application to the society's Extension Secretary, Mr. P. J. Ashton, 72 High Street, Bromley. The topics dealt with are very varied, including the life-histories and habits of insects, birds, and other animals, both terrestrial and aquatic, the rites and customs of Australian aborigines, the physical properties of water and of air, the solar system, and others in the realm of science, besides a number illustrative of history, English literature, travel, and topography. The selection offered is admirable, and can be unreservedly commended to the notice of schools, societies, and other educational bodies.

WE have already referred in these columns (December 2, p. 743) to the film record of this year's Mount Everest Expedition, which was taken by the official photographer of the expedition, Capt. J. B. L. Noel. The film is now being exhibited at the Philharmonic Hall, Great Portland Street, W., so that all may have an opportunity of seeing this wonderful picture-story; the proceeds are to be devoted to the cost of a third expedition. It is a wonderful and inspiring entertainment. The first part shows the country through which the expedition passed on its way to Mount Everest, and it is ably described by Capt. Noel. The second section deals with monastic life in Tibet, and records the curious ritual dances which the party was so fortunate to see at the Rongbuk monastery at the very foot of Mount Everest. The



dances are performed by Lamas, attired in fantastic costumes and wearing huge masks, who represent the good and bad spirits the devout will meet in the next world; devil dances, dances in which ghouls carry a small dummy representing a dead body, and a procession of the gods, are among the scenes depicted. The whole scene is accompanied by music recorded by Mr. T. Howard Somervell, who has endeavoured to reproduce the actual sound of a Tibetan band. As may be expected, it consists largely of drum and trumpet, but there is a well-marked rhythm, and Mr. Somervell, who conducts the music himself, manages to keep his orchestra fairly well in time with the dancing figures on the screen, producing a most realistic effect. Anthropologists will welcome this record of Tibetan dances and music. The third section of the film shows the actual assault on Mount Everest. The film is described by Mr. Somervell, who formed one of the high climbing parties. Scene after scene of indescribable grandeur is shown. Many portions of the film, such as those showing the final attempts on the summit from the highest camp, at about 25,000 feet, were taken with a telephoto lens. The music played in the interval and during the exhibition of the film by Mr. Somervell is based on Nepalese and Tibetan airs and pastoral music, and some of the tunes provide very beautiful though simple subjects. "Climbing Mount Everest" is more than an entertainment; it is a story of high adventure, of great endeavour, which was robbed of success chiefly by the bad weather encountered in the last stage of the journey.

THE College Board of the London Hospital is offering for competition the Liddle Triennial Prize of 12*l.* for the best essay on "Rheumatic Fever: its Cause and Prevention." The last day for the receipt of essays is June 30, 1923. They should be sent to the Dean of the College, Turner Street, E.1.

THE Foulerton Award of the Geologists' Association for the year 1923 has been given by the Council to Mr. A. S. Kennard, F.G.S. Mr. Kennard was associated with Mr. M. A. C. Hinton in the paper on "The Relative Ages of the Stone Implements of the Lower Thames Valley," and with Mr. B. B. Woodward in the production of several important papers on the Post-Pliocene non-marine mollusca of England and Ireland.

THE international review *Scientia* promises its readers next year "a great international inquiry into the Einstein theories." It proposes as the fundamental purpose, first, to make the theory itself accessible to all philosophically minded persons, whether or not they are mathematicians; second, to submit the theory to an objective, unprejudiced, exhaustive criticism, which, by making clear the weak points in need of revision, shall give them their true value as objections; and third, to endeavour to appreciate the value and importance of the theory and the part it has played in the general progress of science.

THE following awards have been made by the Society of Engineers (Inc.) for papers read or published during 1922:—President's gold medal to Dr. C. V. Drysdale, for his papers "The Testing of Small Electrical Plant"; Bessemer premium to Mr. E. E. Turner for his paper "The Atlantic Cruise of H.M. Airship R 34"; Nursey premium to Dr. Herbert Chatley for his paper "The Physical Properties of Clay-Mud"; Society premiums to A. S. E. Ackermann for his paper "The Physical Properties of Clay" (fourth paper), and to C. H. J. Clayton for his paper "The Economics of Arterial Land Drainage"; W. Dinwoodie for his paper on "Wave Power Transmission"; Clarke premium to R. C. Hill for his paper on "The Submersible Pump"; and Geen premium to A. G. Short for his paper on "Heating."

A SERIES of new charts of the currents of the North Sea is contained in a paper by Dr. G. Böhnecke (Veröfentlich. Inst. f. Meereskunde, Berlin, N.F. Ser. A, Heft 10, 1922). The charts are based mainly on a study of the data representing the variations in the salinity of the area in question.

THE Library Press, Ltd., 26 Portugal Street, W.C.2, will shortly publish a work entitled "Fur Dressing and Fur Dyeing," by W. Austin, consulting chemist to the fur industry, which is intended to cover very completely the subjects treated of, and to supply a want felt by workers in the industry.

DR. C. DAVISON has in preparation (for publication in June next if enough copies are subscribed for) "A History of British Earthquakes," in which about 1200 earthquakes in the British Isles from 974 to 1921 will be dealt with. The work will be illustrated by 91 maps and 9 diagrams, and it will cost 32*s.* net. Orders should be sent, with remittance, as soon as possible to the author, 70 Cavendish Avenue, Cambridge.

A BIBLIOGRAPHY of meteorological literature, prepared by the Royal Meteorological Society with the collaboration of the Meteorological Office, is now given as a separate publication for each half-year. No. 2 of the series, which deals with literature received from July to December 1921, has just reached us. This half-yearly issue takes the place of the bibliography previously given in the Quarterly Journal of the Society. The publication has become of considerable value to a small body of workers actively engaged on meteorological research and to others who desire to keep abreast of advances in meteorology. Meteorological science is, without doubt, making considerable advance at the present time, and increased activity is given to the subject by such publications, especially with regard to the many intricacies of the upper air, not only in this country but by most countries the world over.

DR. T. F. WALL thinks that the comment of our engineering contributor, appended to his letter in NATURE of December 16, p. 810, may lead to a possible misapprehension as to wherein lies the novelty of the condenser formed by inserting in

dilute sulphuric acid two lead plates pasted with an oxide of lead—that is to say, using plates of the same nature as are used in secondary cells. The aluminium electrolytic condenser is an electrostatic type of condenser, whereas in the arrangement of pasted lead plates in dilute sulphuric acid the energy is stored in the form of chemical energy, and it is in this respect that the novelty of the new type of condenser appears. "For this reason," Dr. Wall adds, "the term 'electro-chemical condenser' more correctly describes the action of the pasted lead plate arrangement than the term 'electrolytic condenser.'"

The third edition, recently issued, of the General Catalogue of the Oxford University Press is a volume of 480 pages. Supplementary to the catalogue itself is an alphabetical list of authors and editors extending to no less than 128 pages. A preface gives some

interesting statistics, and the activity of the press is illustrated by the fact there stated, that it publishes, in one way and another, more than two books every day. The fifth section of the catalogue deals with books on natural science, including mathematics, physics and chemistry, astronomy, geology, biology, and the history and methods of the sciences. The present volume is more than a mere catalogue; besides giving many bibliographical details—including size in inches, number of pages, and date of publication—it sets out the full contents of books in several volumes and of joint works by several authors. It describes not only all Clarendon Press books, but also all books published by the press for learned societies other than the University of Oxford. The fact that many of these books are in their nature unremunerative affords good evidence of the service rendered by the press to the cause of education and learning.

### Our Astronomical Column.

GREAT METEOR OF DECEMBER 6.—This brilliant object passed over Lincolnshire at 11<sup>h</sup> 40<sup>m</sup> and illuminated the north-east part of England with remarkable intensity. It was seen so far away as Armagh in Ireland, where the observer considered that its refulgence overpowered the light of the moon. A number of observations have been received, and they indicate that the radiant point was in Taurus at about 56° +8°, and that the luminous flight of the object commenced in the neighbourhood of Grantham; its direction was north-north-west. It passed nearly over Lincoln and Grimsby, and at the latter place its height appears to have been 24 miles. Continuing its course, it fell to about 2 miles in height when a short distance south-east of Hedon, near Hull, and about 2 miles further on probably fell to the ground. No meteorite has, however, been reported as having been discovered up to the time of writing, but such an object might very easily escape detection.

The meteor appeared so late at night that, in spite of its great lustre, it was noticed by comparatively few observers.

STELLAR TEMPERATURES AND PLANETARY RADIATION.—In an earlier communication, Dr. W. W. Coblentz gave estimates of the temperatures of sixteen stars as determined from their spectral energy distribution, which was obtained by means of a new spectral radiometer, consisting of a series of transmission screens and a vacuum couple. By means of these screens, which, either singly or in combination, had a uniformly high transmission over a fairly narrow region of the spectrum and terminated abruptly to complete opacity in the rest of the spectrum, it was possible to obtain the radiation intensity in the complete stellar spectrum as transmitted by our atmosphere. The standard used for comparison was a solar type star  $\alpha$  Aurigæ, type G<sub>0</sub>. Being now equipped for making radiometric measurements of the sun, the effective temperature of which is known with a considerable degree of accuracy, Dr. Coblentz communicates the results of this comparison in the Proc. of the U.S. National Academy of Sciences, Vol. 8, No. 11, Nov. 1922. In this he describes the apparatus and method of procedure. He finds the agreement between the observed temperatures of  $\alpha$  Aurigæ and the sun satisfactory, and thus verifies the previous measures of stellar temperatures, which

range from 3000° K for red, class M stars, to 12000° K for blue, class B stars. In the case of the planets, Dr. Coblentz differentiates between the thermal radiation as a result of warming by exposure to solar radiation and the heat radiated by virtue of a possible high internal temperature of the planet itself. The planetary radiation he finds increases with decrease in the density of the surrounding atmosphere, and as a percentage of the total radiation emitted he gives the following values: Jupiter 0, Venus 5, Saturn 15, Mars 30, and the Moon 80.

SPECTROSCOPIC PARALLAXES OF B STARS.—Mr. D. L. Edwards read a paper at the meeting of the Royal Astronomical Society in November on the pioneer work on these stars that has been carried out at the Norman Lockyer Observatory, Sidmouth, where 200 negatives have been studied and the intensities of various lines correlated with respect to type and absolute magnitude.

The helium lines at 4472 and 4026 were found to be good indexes of spectral type, and by their aid some gaps in the Harvard series were filled. Line 4472 was found to vary also with absolute magnitude. The measures of the intensities of lines could be made very accurately by noting the point of disappearance in a darkened wedge.

The difficulty in getting absolute magnitudes was that very few trigonometrical parallaxes of B stars had been obtained. It was necessary to use also parallaxes derived from proper motions, and the hypothetical parallaxes already published for many binary stars. In the discussion it was noted that the assumed mass used in getting the latter was twice that of the sun, but that this is probably too small for B stars. The use of a larger mass would reduce the hypothetical parallax. For this and other reasons it was felt that, while there was every reason to believe the method would prove a very useful one, it was advisable to look on the calibration of the curves as provisional. Mr. Edwards used Kapteyn's value, 0".04, for the parallax of  $\eta$  Tauri (in the Pleiades), but some recent determinations give 0".01.

It is of particular importance to extend our knowledge of the limits of absolute magnitude of the B stars, since the results will have important bearing on the distances of the globular clusters.

## Research Items.

SCIENCE AND PHILOSOPHY.—An article by Sir Oliver Lodge appears in the December number of *Scientia* on "The Philosophy of Science or the Principles of Scientific Procedure." Sir Oliver endeavours to draw a clear distinction between questions which definitely and legitimately belong to science, and those which, though of interest to science, belong to philosophy and cannot be answered by the ordinary methods and procedure of science. The size of an atom is an example of one, the infinity of space of the other. Sir Oliver is quite ready to admit that we can make no sharp separation between our philosophic, artistic, and scientific interests, which are an integral part of human nature and inextricably combined, but he seems to think that on the objective plane we can separate out the different realms and clearly demarcate their frontiers. No one is likely to dispute that there are certain kinds of fact which admit of being investigated with an isolation which is practically complete. What we want to know is whether any fact enjoys its isolation by right and not in consequence of a practical interest on the part of the investigator who contrives it? Some points in the article illustrate how doubtful this is. Sir Oliver attaches prime importance to the æther of space as a scientific explanation; would he class it as a scientific or as a philosophic problem? How can it be discussed without reference to the infinity of space, which is a question the man of science is to leave to the philosopher? Again, as an example of scientific deduction and prediction we are given the discovery of Neptune, but we are not told where to place or how to explain the failure to discover Vulcan.

OAT STRAW AS A CATTLE FOOD.—S. H. Collins and B. Thomas have an interesting paper in the *Journal of Agricultural Science*, vol. xii, pp. 280-286, 1922, upon "The Sugars and Albuminoids of Oat Straw." The authors set out to answer a question that first occupied the attention of one of them twenty-two years ago. "Why can cattle be fattened on roots and straw in Scotland and not in England?" Limitations of time apparently prevented the prosecution of experimental work then, and in the last twenty years there has been considerable development in our knowledge of animal nutrition, so that the authors can now attack with considerable precision the question as to whether the nutrients available in the straw will supplement the deficiencies of grain feeding. The answer appears to be that good oat straw, mainly owing to its relatively high percentage of albuminoids, may well do this, but oat straw has been found to vary in this percentage between 1.12 and 8.05. The low percentages are usually for the straw from the south of England, the high from Scotland; this may be, in part, a question of latitude, but the high figures for Cumberland and Westmoreland, and the values for differently-manured crops, lead the authors to think that good husbandry and suitable supplies of organic nitrogen are even more important. These investigations certainly seem to bring the original question appreciably nearer solution. An interesting point in the sugar estimations reported is the fact that the main sugar of the straw appears to be levulose, while the main digestible carbohydrate constituent of the grain is the dextran starch. If the ideal carbohydrate for nutrition be cane sugar, then this is an additional argument for the good straw proving a valuable supplement to the grain ration.

DEEP ROOT SYSTEMS OF CROP PLANTS.—The difficulties attending the study of the root systems *in situ* has led to a comparative neglect of this important branch of research until recent years. Prof. J. E. Weaver, F. C. Jean, and J. W. Crist, in the "Development and Activities of Roots of Crop Plants" (Carnegie Institution of Washington, 1922), are to be congratulated on realising the urgency of this problem. The value of this work is much enhanced by the numerous sketches of actual root systems made during excavation, together with full details of environmental conditions and experimental results. Repeated investigations at various stations indicate that all cereals possess two distinct groups of roots, one spreading in a more or less horizontal direction in the upper layers of soil, and the other penetrating deeply into the subsoil to a depth of six or seven feet. The lower roots are often much branched and appear to be of the normal absorbing type. In potatoes, on the other hand, the original shallow roots turn vertically downwards and form the deeper portion of the system. As a general rule, only the first six or eight inches of soil are regarded as being of much value in plant nutrition, but controlled experiments indicate that these deep roots play a great part in water absorption, as much or more water often being removed from a depth of three feet as from the surface layers. Maize was proved to absorb large quantities of water from the fifth foot. It was similarly shown that such fertilisers as nitrates were freely removed from the lower soil depths, to five feet in the case of maize, and at least two and a half feet with barley and potatoes. Furthermore, when roots came into contact with a fertilised layer they developed more strongly and branched more profusely, and at the same time normal penetration into the soil below was apparently retarded. The depth at which manures are placed in farm practice must therefore have a considerable effect on root development, and surface applications during times of drought may be very detrimental by keeping the roots from penetrating into the deeper layers with greater water supply. The authors conclude that "the deeper soils are not only suited to plant-life, but that they play an exceedingly important part in the life of the plant, and deserve careful consideration in a study of crop production."

BOTTOM-LIVING COMMUNITIES IN THE SEA.—A very full account of the biology of the Danish crustacea, *Gammarus locusta*, and *Mysis inermis*, *flexuosa* and *neglecta*, is given by H. Blegrad in the twenty-eighth Report of the Danish Biological Station (Copenhagen, 1922). The work has interest in connexion with Dr. Petersen's studies of bottom-living communities in the sea. It is not nearly enough that the numbers of animals inhabiting a unit area should be known; some good estimates of the rates of reproduction and the number of generations that occur throughout a year, for example, are necessary if we have to attempt a measure of the productivity of a sea-bottom area. The object of the memoir under notice is to supply some information on these subjects.

MOLLUSCS OF THE COLORADO DESERT.—Dr. S. S. Berry's notes (Proc. Acad. Nat. Sci. Philadelphia, lxxiv, 1922, pp. 69-100) on the molluscs of the Colorado Desert include short descriptions of specimens belonging to eight genera, most of them represented by a single species, but one genus (*Micrarionta*) is represented by five species, two of which are new. This land snail fauna is confined to the steep mountain slopes, while the fresh-water mollusca are centred

around the relict-covered bed of the ancient lake Cahuilla—i.e. the Colorado Desert in the exact original sense of this term. The enormous numbers of shells present in many parts of the valley and the discovery of many of the same species still flourishing in certain of the outlying springs and rivulets have long ago attracted attention to this section of the fauna. A list of papers on the mollusca of the Colorado Desert is given.

ANIMAL ASSOCIATIONS OF SOME CRUSTACEA.—A memoir on the Pontoniinae—a sub-family of the decapod Crustacea—based chiefly on material in the collection of the Zoological Survey of India, is contributed by Dr. Stanley Kemp to the Records of the Indian Museum (xxiv. 1922, pp. 113-288, 9 pls.). A detailed systematic account of and keys to the genera and species are given, and Dr. Kemp directs attention to the ability shown by members of the sub-family to form associations with other animals. Some are found on sponges, others on actinians, on Alcyonaria, or on corals, a few on starfishes and sea-urchins, many live on crinoids, a considerable number of species live in the mantle cavity of bivalve molluscs, and some are known from the branchial sac of ascidians. In the case of those which live in the mantle cavity of bivalve molluscs, in practically every example a male and female prawn are found together in the same mollusc, and Dr. Kemp infers that after the prawns are once established in their host they never leave it. A list of the animal associations recorded in the Pontoniinae is given.

AMERICAN OLIGOCENE MAMMALS.—Mr. W. J. Sinclair has two papers on American fossil vertebrates in a recent number of the Proceedings of the American Philosophical Society (vol. lxi. 1922, with text figs.). The first, treating of "The Small Entelodonts of the White River Oligocene," discusses the relationships of *Archaotherium coarctatum*, Cope, and *A. mortoni*, Leidy, in the light of fresh specimens acquired by one of the Princeton Expeditions. After a careful analysis it is suggested that, so far as the assumed primitiveness of *A. coarctatum* is concerned, every one of its characters which might be regarded as primitive is possessed in some degree by specimens which differ from it in other respects, so that it would be necessary either to name every variant or to refer all to one species for which the name *A. mortoni* would have priority. The other paper, on "Hydracodons from the Big Badlands of South Dakota," distinguishes four specific types:—*H. arcidens*, Cope, *H. nebrascensis*, Leidy, *H. apertus*, sp.n., and *H. leidyani*, Troxell; and their range in time is shown in tabular form. The distinctions between these species, or possibly subspecies, are based primarily upon structural differences in the upper posterior premolars. No intermediate stages have been observed.

THE LAVAS OF SNOWDONIA.—A marked gap in our detailed knowledge of the igneous rocks of the Snowdon area has been filled by Howell Williams in a recent paper in the Proceedings of the Liverpool Geological Society (vol. 13, part 3, p. 166, 1922). The author deals with the country near and mainly east of Capel Curig, tracing the devitrified rhyolitic lava-flows of Snowdon across the district. Considerable attention is given to alterations due to solfataric action, and the puzzling "bird's-eye slates," with their strings of small ellipsoids of calcite arranged across their bedding, are compared with those of the Lake District, and are attributed to an epoch when carbon dioxide was the principal escaping gas. These unusual rocks are limited to an horizon between the middle and uppermost rhyolites of the Capel Curig suite.

EARTH CURRENTS IN FRANCE.—In *La Nature* (November 25, p. 339, and December 2, p. 355) Dr. Albert Nodon has described a new series of researches upon the electric currents flowing in the earth. An observing station for this purpose was set up in the summer of 1921 near Sauveterre in the Basses Pyrénées; the district is far removed from any industrial electric circuits, being in a wide, well-watered prairie on clay soil, the humidity of which is probably fairly constant; it is therefore well suited in many important respects for such observations. Four overhead wires (the lengths of which are not stated) branch out in directions north-south, east-west, south-east to north-west, and south-west to north-east, from a small observatory. The earth-contacts at the ends of the wires were made by large zinc plates; the contact electro-motive forces from these plates annul one another and appear to have given no trouble. The currents were measured by a milliampere-meter, eye-readings being taken with a lamp and scale; no continuous photographic registration is arranged. The conductivity of the soil in various directions is measured from time to time by applying a known E.M.F. to the wires. Other observations include the earth's horizontal magnetic force, and the intensity of penetrating radiation, the latter being measured by a delicate electrometer in a closed metal case. The currents which flow along the direction of latitude appear to be small and invariable in direction, namely, from east to west; those from north to south are very variable both in direction and magnitude; the currents in the intermediate directions agree with the resultant of the east-west and north-south currents along these directions. The conductivity of the soil appears to vary in parallel with the intensity of penetrating radiation, and also to be augmented when the earth currents are large. Various other correlations, with meteorological and solar phenomena, are indicated, but the results can only be regarded as provisional in view of the short period over which the observations extend.

STREET LIGHTING.—A meeting of the Illuminating Engineering Society, on December 12, was devoted to a discussion on street-lighting. Mr. Haydn T. Harrison, in an introductory paper, pointed out the importance of correct distribution of light and described several devices for improving the natural distribution of illuminants, notably the holophane lantern and the "longitudinal system" for which he himself was responsible. He pointed out that the classification of streets in terms of minimum illumination adopted in the United States agreed closely with that recommended in this country, and urged that "minimum horizontal illumination" was the best basis of specification for public lighting. A contribution by Mr. L. Gaster dealt mainly with street lighting in relation to traffic, and some figures were quoted showing how the diminished lighting in war time had contributed to the increase in street accidents. Experiments in 32 American cities indicated that 17.6 per cent. of accidents occurring at night were due to inadequate illumination. Dr. Clayton Sharp gave an interesting survey of methods adopted in American cities. A feature of such tests has been the utilisation of a length of road for actual experiments with different forms of lamps. Another point, mentioned by Mr. Thomson, chairman of the Street Lighting Committee of the Westminster City Council, is the desirability of arranging lights so as to illuminate the exteriors of important buildings, so as to render them visible by night as well as by day. The advice of architects in considering this aspect of public lighting would be of value.

Weather Cycles in Relation to Agriculture and Industrial Fluctuations.<sup>1</sup>

TWO years ago Sir William Beveridge was led to investigate the problem of weather periodicity from a new point of view, or at least with materials hitherto unused—using wheat prices in past centuries as evidence of harvest yields and so of the weather. The investigation falls into three stages, namely:

(1) Construction of an index of wheat price fluctuation in Western Europe from 1550 to 1869, the index showing the price in each of those 370 years as a percentage of the average price for 31 years of which it is the centre.

(2) Harmonic analysis of this index for about 300 years to 1850 in order to discover periodicity. In this analysis all possible trial periods between 2½ and 84 years in length have been examined and every apparent periodicity has been tested by analysing separately the two halves of the sequence. The result of the analysis is remarkable; not one or two but many distinct periodicities—thirteen or more—are suggested, and the suggestions are confirmed in varying degrees by the discovery of similar periodicities in meteorological records. In view of all the evidence, two of the periods—of 5·1 years (found independently by Capt. Brunt and Mr. J. Baxendell), and 35·5 years (found by Dr. Brückner in 1890)—may be regarded as "certain," though not necessarily the most important. Seven others, with lengths 5·67, 9·75, 12·84, 15·23, 19·90, 54·0, and 68·0 years, are classed as "nearly certain"; all of these show more strongly than the Brückner and many of them more strongly than the Brunt-Baxendell cycle. Four more periods of 3·41, 4·41, 5·96, and 8·05 years are "probable." There are six other "possibilities" including an 11-year period, corresponding in phase and in instability as well as length to the sun-spot period.

(3) Comparison of deductions from this analysis of wheat prices before 1850 with the actual rainfall from 1851 to 1921 on the assumption that the meteorological factor most uniformly adverse to wheat in Western Europe is rain.

For this purpose eleven out of the thirteen "certain," "nearly certain," and "probable" cycles, with the lengths and phases given by harmonic analysis, have been drawn for the years 1851 to 1921 and combined by a simple graphic method. The resulting "synthetic curve" shows a large measure of agreement with the actual rainfall for those years; for the 55 years to 1905 the coefficient of correlation is 0·38 or about five times its probable error. The principal droughts of the last seventy years, including that of 1921, are particularly well shown and so foretold by the "synthetic curve."

This investigation, it is submitted, establishes the existence, importance, and persistence over more than 300 years, of definite periodicities in the yield of European harvests, some or all of which must be attributed to cycles in the weather. It opens up the possibility of valuable forecasts of general conditions. But no such forecasts either as to the year 1923 or any other year are now possible, and Sir William Beveridge makes none. He claims for his investigation nothing more than that it affords a starting-point for more detailed studies; his hope is that competent meteorologists may be encouraged once again and more hopefully to take up these studies.

Mr. R. A. Fisher suggested that a periodicity in

yields is not necessarily an indication of a periodicity in weather since it may indicate merely a periodicity of economic conditions. For example, the amount of a farmer's crop is affected by the state of the labour market and the state of his own bank account. Nevertheless, if any considerable and persistent periodicity really exists in the weather, it would be likely to affect the crops and hence their prices with a similar periodicity. The crop data suitable for an investigation of this kind should be obtained, however, not under commercial but under experimental conditions. The figures obtained at Rothamsted differ from those of the Ministry of Agriculture. Detailed examination of these figures and comparison with rainfall records, indicates that rainfall apparently accounts for 30-50 per cent. of the total variation in crop.

Examination of the distribution of the rainfall in each year shows that slow changes in yields seem to be affected only by (a) the total rainfall in the year, and (b) the excess of summer and winter rain over that in spring and autumn. Between the two latter there is a striking difference. In total rainfall there have been spells of wet and dry years, two wet spells about 35 years apart. But these spells can scarcely account for more than 10 per cent. of the changes in the yields, though they may account indirectly for a larger percentage, e.g. by favouring weed infestation. A period of 70 years is not enough, however, to determine periodicity; in any case the quantitative value of the spells is not great, probably less than 7 per cent. of the variation in crop: the remaining 93 per cent. appears to be quite fortuitous. It is here that the weak point occurs in any argument which would make the yield of farm crops to be dependent on the weather.

The change which variation in excess of winter and summer rain over that of spring and autumn causes is more interesting than that caused by total rainfall. Examination of ten-year means reveals a steady increase for the last 70 years with no sign of slackening. The effect of an increase in December rain on the wheat yield is rather striking; on duned plots, for example, a loss of more than 1½ bushels per acre occurred.

The general result of examining these weather records is that in most features the succession of seasons appears to be wholly fortuitous, and in all features by far the larger part appears to be fortuitous. The two cases in which distinct changes are noticeable account for a very small proportion of the variation in yield. It is of course not denied that any series of values, however arbitrary, may be expressed by Fourier's expansion as a number of harmonic cycles; but in the case of the weather, these cycles will be for the most part of short duration, and cannot be expected to reproduce themselves in the series of crop yields. For given weather the crop may be predicted with some accuracy, but Mr. Fisher is of opinion that the crop cannot be predicted even approximately without a detailed prediction of the weather.

Dr. Simpson remarked that meteorologists might be divided into two classes, those who had discovered a period and those who had not. The latter as a rule did not believe in periodicity, while the former generally believed only in the period they had themselves discovered. He exhibited on the screen a table showing 83 periods discovered by various investigators in solar and meteorological phenomena. These ranged from 1800 years to 2 hours, and he directed attention to the fact that from such a large

<sup>1</sup> Joint discussion of Section A (Mathematical and Physical Science), F (Economic Science and Statistics), and M (Agriculture) of the British Association at Hull on September 7.

number of periods—no attempt had been made to make the table complete—it would not be difficult to find a period near any specified period, especially if one were allowed to consider multiples and sub-multiples. He then discussed the two chief meteorological cycles, the Brückner cycle and the sunspot cycle. The hundred-year record of London rainfall has been analysed for a 35-year period, and a curve added to a diagram of monthly totals to show on the same scale the contribution of the cycle to the total rainfall. The amplitude of the cycle is absolutely insignificant in comparison with the monthly variations. Dr. Simpson admitted that there is an appreciable correlation between sunspots and meteorological factors, but as sunspots have no true periodicity they cannot introduce a periodic term into meteorological phenomena.

Turning to Sir William Beveridge's results Dr. Simpson regretted that he had not seen Sir William's recent paper in the *Journal of the Statistical Society* but only his papers in the *Economic Journal*, because the periods on which Sir William appears now to rely are different. He was prepared to admit that Sir William Beveridge had discovered certain periodicities in his curve of prices of wheat which were many times greater than one would expect by chance, but he strongly contended that these were meteorological periodicities. Sir William Beveridge laid great stress on a periodicity discovered by Capt. Brunt in Greenwich temperature, 5.1 years, which coincided with one of his cycles, but it was pointed out that Capt. Brunt discovered 9 cycles, four of which had greater and four smaller amplitudes than this particular cycle. Also Capt. Brunt's cycle of 5.1 years reduced the standard deviation of mean monthly temperatures at Greenwich only from 2.80 to 2.77, an insignificant change.

Dr. Simpson also criticised Sir William Beveridge's synthetic curve and asked why that curve should be compared with rainfall. There appeared to him no more reason why it should apply to rainfall than to any other meteorological or economic or even biological factor which might conceivably affect a harvest. In conclusion, admitting all that Sir William claimed to have done, he did not think that a prediction which gave a correlation coefficient with actuality of only 0.38 had any practical value. When Sir William had increased his correlation coefficient to about 0.83 he would be a valuable forecaster, but not until then.

Mr. Udny Yule said that the comments of Dr. Simpson seemed to him unfair. It must certainly

be recognised that mere inspection of data was wholly inadequate and might lead to unfounded ideas as to the existence of periodicities, but this criticism had no bearing on work carried out by the periodogram method. He felt a good deal more doubt than some previous speakers on the question whether crop cycles were or were not a vital factor in the general economic cycle, which required far more study. From the statistical side the most important work now to be done is the determination of the crop cycles in areas other than Western Europe, e.g. South America and India; in so far as crop cycles are an important factor in the economic cycle, the resultant in any one country must be a complex effect dependent on the sources of its raw materials. On the side of economic theory it seemed to him there is also work to be done. The treatment of economics is in general static. The economist is too apt to tell us that "in the long run" a pendulum will hang vertically, whereas the whole interest of the pendulum is that it swings, and the problem is why it swings and how it swings. The treatment of economics should be dynamic. The question might be asked, for example, whether there is not an equation relating production not merely to price but to price and its time differentials, an equation which might (or in given circumstances might not) have a periodic solution.

Prof. H. H. Turner considered that we should be grateful to Sir William Beveridge, first, for producing a long series of annual values, going back much further than our longest rainfall record; secondly, for having himself analysed them completely by the periodogram method, so that others can profit by his analysis; and thirdly, for two considerable successes in the outcome. One of these is remarkable. He had succeeded in forecasting the weather in some sort—a rare, if not unique, achievement up to the present. The other success consisted in isolating several periods which must be further investigated. The periodogram gives us only the beginning, not the end of an investigation. Having obtained, for example, the definite suggestion of a 15-day period we must then see how it behaves throughout the series; the maximum phase seems to oscillate in this case. Such oscillations frequently occur in manifestations of periodicity which may itself be quite regular; thus, the rotation of the earth is quite regular, but one of its manifestations is sunrise, which swings to and fro. Sir William Beveridge had given us a good start, which it is to be hoped will be followed up.

### Geology of the North Sea Basin.

THE long-standing custom of devoting at least part of a session of the Geological Section of the British Association to matters pertaining to the geology of the district in which the meeting is being held, was extended this year to the consideration of the wider question of the geological history of the North Sea basin, the discussion on this subject being the first of a series held in different sections on various aspects of the North Sea.

The discussion was opened by Prof. P. F. Kendall, president of the section, and was continued by Mr. J. O. Borley, of the Fisheries Research Laboratory, Lowestoft, who described the nature and distribution of the deposits now being laid down. Mr. Thomas Sheppard dealt with the geology of the Hull district, and Mr. C. Thompson contributed an interesting paper on the present rate of erosion of the coast of Holderness.

The main tectonic lines of the British Isles and of

the neighbouring area, the North Sea, were produced prior to the formation of the Permian rocks, the three main axes of folding being the Caledonian (N.E. and S.W.), the Pennine (N. and S.), and the Armorican (W. and E. approximately). Later movements, for the most part along these old lines, were responsible for the changes in the distribution of land and water which have taken place.

The region now occupied by the North Sea appears to have been an area of depression since a very remote period. Thus it is found that movements which took place during late Carboniferous times and during the period, unrepresented by any deposits in Europe, that elapsed before the deposition of the Permian rocks, caused the coal measures to dip into the basin in Holland and Belgium, in Northumberland and Durham, and probably also in Lincolnshire, to emerge at Ibbenbüren.

The sinking of the basin thus formed appears to have continued intermittently in Permian, Jurassic, and Cretaceous times, the Permian and Jurassic deposits in the Durham-Yorkshire area being thicker than in almost any other part of Britain, and the Lower Cretaceous beds (the Speeton clay), being of a deep water type, contrasting strongly with the shallow water and estuarine deposits of that age to be found in parts of Britain more remote from the basin. The chalk also reaches its maximum British development on the East Coast.

After the formation of the chalk, the area was uplifted and much denudation took place prior to the deposition of the Woolwich and Reading beds and London Clay, which marks the commencement of a further downward movement. These Lower Tertiary beds still occupy the London and Hampshire basins and extend below the southern part of the North Sea. Prior to the great denudation which followed the uplift in Miocene and early Pliocene times, they doubtless occupied a much wider area—the then basin of the North Sea with its embayments and estuaries.

Then followed intermittent movements of the Armorican folds in the south of England, Northern France and Belgium extending into Pliocene (Diastian) times.

From this time onwards it is possible to trace the southern and western shores of the North Sea with some degree of accuracy. In Diastian times, Harmer suggests that the coast-line ran from the neighbourhood of Dover across the straits into Belgium, the shore deposits being represented by the Lenham beds and the Diastian of Belgium. The later Pliocene deposits indicate a gradual retreat of the sea to the northwards, the fossils of the Red Crag and Norwich Crag showing a gradual increase in the number of living as compared with extinct species as they are traced from Essex to the Wash.

At the close of Pliocene time much of the southern portion of the North Sea Basin must have been low-lying land, and across this meandered the great rivers of Northern Europe. The estuary of the Rhine, according to Harmer, crossed Norfolk; and in it were laid down the Chillesford beds.

To the north of the Humber the coast-line of this period has been traced by a line of buried cliff with accompanying beach deposits running from Hessele on the Humber, inland to the west of Beverley, and emerging on the line of the existing coast at Sewerby, between Bridlington and Flamborough Head. The plain of marine denudation in front of this old coast-line has been charted and contoured by means of information obtained from numerous borings which have been put down in search of water in the Plain of Holderness.

The next phase was a retreat of the sea and the formation of sand dunes along the foot of the cliff. The geological date is indicated by the occurrence of *Elephas antiquus*, *Rhinoceros leptorhinus*, and hippopotamus in the deposits, a fauna which accompanies implements of Chellean type in the south of England.

Throughout Pliocene times, a gradual refrigeration of the climate was in progress, as is shown by the molluscan fossils and also by the land flora, where remains of this have been preserved; and the next episode was the formation of a great ice-sheet having its radiant point in the neighbourhood of the Gulf of Bothnia. This appears to have displaced the waters of the North Sea at least as far south as the coast of Essex. Retreats and readvances took place, but the final retreat of the ice can be traced with great detail and precision by the drainage phenomena developed along its margin up to its last contact with British shores on the Ord of Caithness.

Oscillations of level accompanied the retreat of the ice and raised beaches were left, but on the completion of the withdrawal the land stood about 80 feet higher than at present. The southern part of the North Sea became a marshy plain, peat bogs covered much of its surface and forests clothed its margins, while great rivers such as the Rhine, Thames, and Weser meandered through it.

A depression to the present level then ensued and the great shallow bay of the North Sea south of the Dogger Bank was formed. The sea ran up the estuaries, and thus the Humber itself and its tributary the Hull came into being.

The work now being carried out by the officers of the Fisheries Board is throwing much light on the distribution of the various grades of material accumulating on the floor of the North Sea at the present time. Both the mineralogical character and the size of grain of the material are being investigated, though, of course, the latter is of more importance from the immediate point of view of fisheries, since it controls to a large extent the distribution of life.

By means of experiments with floats the direction of the main surface currents has been determined, and the maps exhibited by Mr. Borley showed that the floor deposits were spread out under the influence of the same movements. Several different types of material exist on the coast, but in each the grading of the deposits, coarse to fine, is in the general direction of the currents already determined by other means.

Along a great part of the east coast of Britain the North Sea is at present eroding the cliffs at a fairly rapid rate, and this has been measured by Mr. Thompson in the case of the coast of Holderness, which consists of glacial deposits. His method was to take the six-inch Ordnance Survey map published in 1852 and to measure thereon the lengths of all easily identifiable lines running at right angles to the coast, and then to measure up the remains of these lines on the ground. In this manner it was possible to draw the coast-line as it is to-day on the map of 1852 and thus to indicate the strip of land lost to the sea in the last seventy years. This strip varies considerably in width in different parts of the coast, there being a few points at which erosion is practically nil while at others it has caused serious loss.

### New Japanese Botanical Serials.

DURING the last few decades the universities and colleges of Japan have produced a large number of scientific investigators, many of whom have continued postgraduate training for several years in Europe or America. The result is that in Eastern Asia a large number of well-equipped scientific investigators are now actively prosecuting research and there is a danger that, working in a field still

far distant as regards practicable modes of communication, their work may not be sufficiently known in Europe, with corresponding loss of efficiency to the workers in both continents. Japanese scientific leaders are evidently alive to the danger, and the reopening of extensive scientific contact following the gradual cessation of war conditions has been followed by the organisation and issue of a number

of scientific publications, containing communications in European languages, mainly German and English.

Thus there have recently reached this country the first issues of two such new serial publications, the *Japanese Journal of Botany* and the *Acta Phytoclimica*.

The *Japanese Journal of Botany* is only one such publication of nine which are being issued by the National Research Council, Department of Education, Japan. Besides a long communication (53 pp.) by Saito upon the fungi (yeast) occurring naturally in the atmosphere at Tokio, in which a connexion is traced between the number of these organisms present and the meteorological conditions, a series of abstracts follow which summarise the more important papers on botany and allied subjects which have appeared in Japan during January-June 1921. No fewer than thirty-nine papers are thus reviewed, many of economic importance and some of very general interest.

The first number of the *Acta Phytoclimica*, dated March 1922, contains two papers. In the first Asahina and Fujita summarise the researches published by them so far only in the Japanese Journal of the Pharmaceutical Society of Japan. These investigations enable them to assign a constitutional formula to anemonin and to the most important acid derivatives so far obtained from it.

Anemonin is a crystalline product obtained from the acrid ranunculus oil distilled from fresh plants of various species of the Ranunculaceæ and extraction

of the distillate with ether, benzol, or chloroform, but anemonin itself is not the acrid principle. The Japanese workers have a very large phytochemical field in the many interesting natural products of Eastern Asia, and the second paper, by Majima and Kuroda, deals with the pigment extracted by cold benzene from the dried outer portion of the root of *Lithospermum erythrorhizon*. The main constituent of this pigment has been isolated in pure crystalline form and is described as the monoacetyl derivative of the compound,  $C_{14}H_{14}O_5$ , which the authors have named shikonin (from the Japanese name for the plant "shikon.")

It is proposed to issue one volume of *Acta Phytoclimica* a year, each volume to consist of about 350 pages. The editor is Prof. K. Shibata, Botanical Garden, Koishikawa, Tokyo.

The two papers now published are written, one in German and one in English; communications in French are also acceptable for publication. The journal states that it aims at ensuring a closer correlation between chemical and physiological studies of plant constituents, but these first papers are essentially chemical in outlook. Both journals are well printed, in clear type on good paper, with curves and tables adequately reproduced. In the *Japanese Journal of Botany* three plates are included. Curves and drawings are very well reproduced in these; a lack of contrast in a series of photographs of yeast colonies on agar may be the fault of the original photographs.

## Colloid Chemistry.

By Prof. W. C. McC. LEWIS.

THAT increasing attention is being paid to the subject of colloid chemistry is becoming manifest in various directions. Already the subject has taken its place in the chemical instruction of some if not of all our universities, while the technological literature shows (though as yet to a rather limited extent) that the significance of colloidal behaviour is no longer overlooked in a number of technical operations. The subject is one of comparatively recent growth, for, although originating with Graham more than sixty years ago, its importance has begun to be realised only within the last twenty-five years.

It is not altogether surprising, therefore, that there are still a number of people engaged in chemical work to whom colloid chemistry has not as yet made an effective appeal. To a large extent the further recognition of the subject will depend not only upon the measure of success attending the publication of works such as text-books and memoirs which aim at bringing the subject within the scope of ordered presentation, but also upon the efforts of agencies the aim of which is to correlate the scientific principles and generalisations (in so far as they exist at present) with technical problems and practice, and to demonstrate how numerous and varied are the industrial operations in which colloid considerations are fundamentally involved. In the latter connexion a very useful service has been performed during the past few years by a committee of the British Association in publishing a series of reports on Colloid Chemistry and its General and Industrial Applications. The fourth of these reports,<sup>1</sup> a compilation of more than 380 pages, has been issued, and in view of its undoubted importance a brief indication of its general nature will not be without interest.

<sup>1</sup> Department of Scientific and Industrial Research: British Association for the Advancement of Science. Fourth Report on Colloid Chemistry and its General and Industrial Applications. Pp. 382. (London: H.M. Stationery Office, 1922.) 5s. 6d. net.

As in previous reports the subject matter is considered so far as possible under two heads, namely, subjects mainly academic in nature, and subjects mainly technical. Under the first head we find the following sections: Colloids in analytical problems, cataphoresis, colloid systems in solid crystalline media, molecular attraction, membrane equilibria, disperse systems in gases, the theory of lubrication, and the application of colloid chemistry to mineralogy and petrology. Under the second head are grouped: Colloid chemistry of soap boiling, flotation processes, catalytic hydrogenation, the rôle of colloids in metal deposition, rubber, and colloidal fuels. Each section has been written by a man who is specially conversant with the subject which he treats, and it may be added that the entire work here represented—and it amounts in the aggregate to much—has been given gratuitously.

Among subjects of such a divergent kind it is not easy to discriminate. Some readers will be attracted by the comparative novelty of the idea of introducing colloidal considerations at all into such problems as metallic alloys, mineralogy, and petrology, or the subject of lubrication. Others will be specially interested in obtaining some definite and clear information on subjects which possess a certain degree of familiarity, but about which most of us have, it is to be feared, somewhat confused ideas, subjects such as soap boiling, or ore-flotation, or catalytic hydrogenation. The fact that the latter two subjects are dealt with at all indicates the wide view which the committee quite rightly takes of the nature and range of its activities. The enormously wide scope of certain of the subjects themselves is well demonstrated by the article on disperse systems in gases, which ranges from the pollution of the atmosphere, metallurgical smokes, and problems of chemical warfare to Millikan's work on the charge of the electron. By way of contrast we find in the section on molecular attraction a minute and searching



account of a single problem which is fundamental not only to colloid chemistry but to molecular physics as well. The variety of the subjects here indicated should strengthen the appeal which the report makes to readers possessing widely different individual interests.

Finally, it may not be out of place to direct attention to the valuable assistance which the committee has received from the Department of Scientific and Industrial Research, without which the report could not have been published. To any one appreciating the value of these publications for the advancement of chemical science and industry, it will be apparent that the assistance thus rendered has been wisely as well as generously given.

### • Early History of the Sussex Iron Industry.

MR. RHYS JENKINS, vice-president of the Newcomen Society, formed recently for the study of the history of engineering and technology, who has contributed two papers on the early history of the iron industry in Sussex, has followed this up by some notes on the early history of steel-making in England. His paper deals with the history of the production of steel before Huntsman's invention of cast steel.

That steel was produced in the time of Queen Elizabeth is well known, but very little, if any, research has been done on the history of the industry between that period and about 1750. The earliest mention of a works for the production of steel found by the author is in 1573. He finds that John Glande held a tenement called "A forge of steel" in Ashdown Forest, Sussex. This forge came into the hands of John Bowley in 1525, who still held it in 1548. It appears that Sir Henry Sidney of Penshurst, Kent, the father of Sir Philip Sidney, was a steel maker of that period. Steel was manufactured at Robertsbridge in Sussex with the aid of Dutch labour obtained from the neighbourhood of Delft. The method used was the so-called "finery" process, in which the iron from the blast-furnaces, instead of being cast into sows or pigs, was cast into thin flat bars. Another site of steel forges in Sussex was Warbleton.

An important landmark in the development of the industry was the invention of the cementation process. The earliest mention of this is in 1614, when William Ellyott and Mathias Meysey obtained a patent for converting iron into steel "by means of a reverberatory furnace with potts louted or closed to be put therein containing in them certain quantities of iron with other substances, mixtures and ingredients, which being in the said furnace brought to a proportion of heate doth make and convert the same iron into steel, which steel with other heate temperatures and hammerings to be afterwards given to the same doth make good and fit for the use before mentioned." Ellyott and Meysey were both natives of this country, and there is no suggestion that they employed foreign workmen. The author thinks that this invention may have been a development of the case-hardening process, possibly in the light of knowledge acquired from the manufacture of brass. The works of Ellyott and Meysey were probably situated in London, and in 1616 they obtained another patent for carrying out the main invention with pit coal instead of wood.

Later developments of the industry appear to have taken place to some extent in the Forest of Dean, and also in Yorkshire. Prince Rupert was an inventor of the period, about 1650. On the whole, the best steel seems to have been made in the Forest of Dean. The records of that period indicate that it made good edge-tools, files, and punches.

### University and Educational Intelligence.

CAMBRIDGE.—Dr. A. P. Maudslay has been elected an honorary fellow of Trinity Hall.

GLASGOW.—The University Court has accepted the generous offer, already referred to in this column, of a gift of 25,000*l.* from Mr. Henry Mechan for the establishment of a Henry Mechan chair of public health. In making the gift, in recognition of "the great and important work which is being done by the University of Glasgow," Mr. Mechan made no conditions, preferring that "the accomplishment of my purpose should be left to the University authorities." The department of public health to which the new chair is given has hitherto been joined with that of medical jurisprudence under Prof. Glaister.

LEEDS.—At the meeting of the Court of the University on December 20, the Pro-Chancellor stated that there are now 1535 full-time students as compared with 1646 in the year 1921-22. The local education authorities of Yorkshire are increasing their help to the University. In addition to subsidies from the City of Leeds, the West Riding and the East Riding County Councils and the City of Wakefield, the University now receives financial aid from the North Riding County Council and from the City of York.

The laboratory of the British Silk Research Association has been established in temporary quarters, and the National Bensole Association has instituted researches in the department of fuel and metallurgy. The premises used as a Marine Biological Laboratory at Robin Hood's Bay have been purchased by the University. With the help of a grant from the Government the funds required for the new building of the department of agriculture (the headquarters of agricultural education in Yorkshire) have been secured, and an early start will be made with the work.

The Clothworkers' Company has recently made to the University a gift of 2250*l.* in addition to its earlier munificent endowments.

The Court, on hearing of Prof. Smithells' decision to resign the professorship of chemistry in order to devote himself to scientific investigation in London, "records its profound gratitude to him for service of immeasurable value to the University during the thirty-seven years in which he has held his Professorship. He is one of the founders of the University, which owes more than it can ever express to his unselfish devotion to the public interest, to his untiring labours in the application of science to industry, to his strenuous and at last victorious defence of the recognition of scientific technology as an element in the highest type of university education, and to his undeviating adherence to a high and exacting standard in university studies. The Court rejoices to think that he now hopes to escape from some of the administrative cares which have eaten into the leisure which otherwise he would have devoted to scientific research, and assures him that his name and work will be inseparably connected in future with the history of the rise of the University of Leeds."

The title of Emeritus Professor was conferred upon the following: Percy Fry Kendall, professor of geology, 1904-1922, who retired after reaching the age limit in September; John Goodman, professor of civil and mechanical engineering, 1890-1922, who resigned his chair in September.

Dr. W. H. Pearsall, lecturer in the department of botany, was appointed reader in botany in recognition of his contributions to learning and research, especially in ecology.

A COURSE of eight lectures on "Changing Geographical Values" will be delivered by Sir Halford

Mackinder on Wednesdays at 5 P.M., beginning January 24, at the London School of Economics and Political Science, Houghton Street, W.C.2.

PART I, consisting of ten lectures, of a course on Oil Well and Refinery Technology and Geology of Petroleum, will be given at the Sir John Cass Technical Institute, Jewry Street, Aldgate, E.C.3., during the coming term. The opening lecture, on Monday, January 15, at 7 P.M., will be by Sir John Cadman on "Imperial Aspects of the Petroleum Question."

THE Bureau of Education of the Government of India has just issued a second volume of "Selections from Educational Records," edited by J. A. Richey (Calcutta, Superintendent of Government Printing, India, pp. 504, rupees 63). The period covered by these selections, 1839-59, was one of great educational activity in India, during which provincial systems of education were gradually evolved, and many of the documents reproduced in this volume are of great interest, as are likewise the accompanying series of portraits of statesmen, administrators, missionaries, and unofficial patrons of education. The frontispiece is, appropriately, a portrait of James Thomason, Lieutenant-Governor of the North-western Provinces, 1843-53, who of all the administrators of those times rendered the greatest services to the cause of education in India. Among these not the least was the establishment of the Engineering College at Roorkee which bears his name. Had his appreciation of the needs of the time in regard to the teaching of applied science been more fully shared by the court of directors and their successors, there might have been in India developments comparable with those which in the United States of America followed the adoption by the Federal Government of the policy of endowing colleges of agriculture and mechanical arts. A number of interesting documents are grouped together under the heading: the beginning of professional education—medical, engineering, and legal—and a useful bibliography is given at the end of the volume.

STRIKING testimony of the excellent morale of the students of the University of Hong-Kong was given in the course of an address delivered on November 14 at the Royal Colonial Institute by Sir Frederick Lugard, to whose initiative the inception of the University was primarily due. After speaking of the need for training character in African dependencies, he said: "A university was founded in Hong Kong in 1912 mainly for Chinese students. In the forefront of its declared objects the principles of co-operation and discipline were laid down. This year the community was disorganised by a series of strikes of a political nature. Trade and social life were alike paralysed. It seemed inevitable that the students—as in Egypt and India—would espouse the cause of reaction. But the Vice-Chancellor reports that though it would have been entirely in accord with Chinese student practice elsewhere that the undergraduates should demonstrate on the same side, what actually occurred was a very striking testimony to the success obtained in inculcating the lessons of co-operation and discipline. When the whole of the servants joined the strikers the students devoted themselves with the utmost cheeriness to cooking and to menial household duties. Sir W. Urungate adds that the hostels had never been cleaner. When the staff of mechanics went out the students manned the power station and the medical students unanimously resolved to carry out hospital duties, which are regarded by Chinese as especially derogatory." On the re-establishment of stable government in China the potential usefulness of this university will be vastly increased and it is to be hoped that it will be enabled to rise to the height of its great opportunities.

## Societies and Academies.

LONDON.

**Aristotelian Society**, December 4.—Prof. Wildon Carr, vice-president, in the chair.—Gerald Cator: The one and the many. Contents of monadic type, which seem to occur in experience, prove on examination to be "convergence illusion effects." To admit this, however, is fatal to the claims of logic. The question, "How are synthetic judgments possible?" can only be answered by the denial that there can be genuine judgments, as contrasted with psychological compositions of representations. The writ of logic, we should have to say, does not run in our world. To this dilemma the intellectualist metaphysics of St. Thomas Aquinas offers a legitimate though not dialectically-necessary way of escape. According to its every character of the world, correlative to an intelligence of any grade, is a function of the position of that intelligence in the scale of beings, and the human intelligence is intelligence at threshold value. It follows that the form of the human universal will be the unification of a multiplicity by reference to a *point de repère*. But this is precisely the structure of a "convergence illusion effect." Convergence illusion effects may, therefore, be genuine universals at threshold value, and consequently our world may be continuous with the intelligible world.

**Society of Public Analysts**, December 6.—Mr. P. A. Ellis Richards, president, in the chair.—E. W. Blair and T. Shirlock Wheeler: A note on the estimation of form- and acet-aldehydes. In investigations of the action of oxygen and ozone on various hydrocarbons, the formaldehyde and acetaldehyde present were estimated by finding the total aldehydes by Ripper's bisulphite method (*Monat. für Chem.*, 21, 1079), and formaldehyde alone by the cyanide method. In solutions containing formaldehyde, formic acid, hydrogen peroxide, and a trace of ozone these substances were estimated serially, formic acid with N/100 alkali, ozone with neutral potassium iodide, hydrogen peroxide by Kingzett's method (*Analyst*, 9, 6), and formaldehyde by Romija's method.—H. A. Peacock: Note on the presence of sulphur dioxide in cattle foods after fumigation. Sulphur dioxide may be absorbed by cattle cakes and meals during fumigation, but after about a week the sulphur dioxide disappears. The amount absorbed depends on the variety of cake—the harder cakes absorbing less than the softer—and the condition of the feeding stuff, *i.e.* whether in block or powder form.—C. H. Douglas Clark: A sliding scale for the convenient titration of strong liquids by dilution and use with aliquot parts. The device enables the operator to see at once what alternative dilutions are available in any particular case in order to obtain a convenient burette reading at the end of titration, and it assists in choosing the most suitable dilution.—D. W. Stewart: Some notes on the unsaponifiable matter of fats. The proportion of sterol in the unsaponifiable matter varies from 48 per cent. in maize oil to 7 per cent. in palm oil; and from 38 per cent. in lard to 9 per cent. in hardened whale oil. Highly hardened fats still contain sterol. The cholesterol acetate of animal fats melts at 114 to 114.5° C.; the phytosterol acetate of vegetable fats is a mixture, a fraction of which melts at 125° or above, but some pure vegetable oils yield a fraction melting about 114° C. These facts are utilised in analysing margarines.—Norman Evers and H. J. Foster: Note on the sulphuric acid test for fish liver oils. The addition of natural oils increases the sensitiveness of the test to

a remarkable extent. The brown colour produced by sulphuric acid with liver oils after oxidation, behaves in exactly the same manner as the violet colour with the fresh oils, being similarly increased by the addition of natural oils. Oxidation of the natural oils destroys this power, but it is unaffected by hydrogenation.

The Optical Society, December 14.—Sir F. W. Dyson, president, in the chair.—T. Smith: A large aperture aplanatic lens not corrected for colour. A lens suitable for spectroscopic work with aplanatic corrections for all zones may have as large an aperture as  $f/1$  or still greater, all the surfaces being strictly spherical. An actual lens made by Messrs. Ross, Ltd., of 3 inches focal length and 3 inches aperture possesses corrections comparable with those given by the theoretical investigation. With a slightly reduced aperture, correction for colour may be obtained without prejudice to the quality of the spherical corrections. The production of suitable glass discs is the outstanding difficulty in the way of great increases in the relative apertures of telescope objectives.—T. Smith: The optical cosine law. The law of refraction, the sine law relating to coma, and other exact laws of optical instruments are particular cases of a very general law which assumes the form of a cosine relation. As an example of the application of the law, the principles which should govern the construction of a variable power telescope yielding aplanatic correction at all magnifications are investigated.—S. Weston: A constant bubble. The alteration in the length of the air bubble in a spirit level due to variation of temperature is avoided in the new type of level produced by Messrs. E. R. Watts and Son, Ltd., known as a "constant" bubble. The first consideration is to obtain the exact proportion of air and spirit. The cross section of the tube containing the liquid is so shaped that as the temperature is raised and the surface tension gradually decreased, only the cross sectional area of the bubble is affected, its length remaining unaltered.

## PARIS.

Academy of Sciences, December 4.—M. Emile Bertin in the chair.—M. Guillaume Bigourdan was elected vice-president for the year 1923.—G. Bigourdan: The Observatory of Paris, on the 20th anniversary of its construction. An historical synopsis of the work done at the Observatory from its completion in 1672 to 1699.—Maurice Hamy: The measurement of small diameters by interference. A development of Michelson's formula, without the restriction  $a=0$  ( $a$  being the ratio of the width of the slits to the distance between their centres).—A. de Gramont: Quantitative researches on the line spectrum of vanadium in fused salts. Two tables are given showing the persistence of the chief vanadium lines by ocular and photographic observations. In the visible spectrum the sensibility is 1 in 1000, and this is increased by the use of photography to 1 in 100,000. The method can usefully be employed in the examination of minerals.—Sir William H. Bragg was elected correspondant for the section of physics, in the place of the late M. René Benoit, and J. B. Senderens correspondant for the section of chemistry, in the place of the late M. Barbier.—A. Schuermasse: Observations of the Skjellerup comet (1922d) made with the equatorial of Nice Observatory. Positions of the comet and comparison stars are given for November 29 and 30. The comet is of the 11th magnitude.—J. Le Roux: The gravitation of the systems. Reply to some criticisms by

M. Brillouin.—J. Haag: The constancy of the homogeneity of the fluid representative of the different possible states of a gaseous mass.—Maurice and Louis de Broglie: Remarks on corpuscular spectra and the photo-electric effect.—Pierre Salet: The law of dispersion of prismatic spectra in the ultra-violet. In an earlier paper the author has given a formula which represents exactly the observed relation between the wave-length and the position of a line in the spectrum, and this was verified for wave-lengths between  $\lambda 3800$  and  $4900$ . Proof is now given of the validity of the formula in the ultra-violet to  $\lambda 2250$ .—F. Croze: The place of the ultimate lines of the elements in the spectrum series and their relations with the resonance lines.—Pierre Steiner: The ultra-violet absorption spectra of the alkaloids of the isoquinoline group. Papaverine and its hydrochloride. The absorption curve of papaverine is not that obtained by the addition of the absorption curves of its constituents: the effect of the isoquinoline nucleus preponderates.—Marcel Sommelet: Tertiary amines derived from benz-hydrilamine.—Raymond Delaby: The alkyl-glycerols. The conversion of the vinyl-alkyl-carbinols into alkyl-glycerols. The ethylenic alcohol is treated with bromine in acetic acid solution, these converted into acetins by prolonged boiling with sodium acetate, and the products separated by fractional distillation. The acetins are hydrolysed by a solution of hydrochloric acid in methyl alcohol.—P. W. Stuart-Menteath: The San Narciso mine in Guipuzcoa.—P. Viennot: The tectonic of the region of Bagnères-de-Bigorre and of Lourdes.—Louis Dangard: Contribution to the geological study of the bottom of the English Channel, based on recent dredgings by the *Pourquoi-Pas?* (August-September, 1922). The results are given on a chart, with special reference to outcrops of the Lias and Eocene.—M. Lecoindre: The stratigraphy of the north of Chaouia (Western Morocco).—J. Cluzet and A. Chevallier: The radioactivity of the springs of Echailon. The deposits forming these springs are rich in radiothorium. This is the only spa in France admitting the therapeutic utilisation of thorium emanation.—G. Reboul: The determination, in cloudy weather, of the vertical movements of the atmosphere: the influence of clouds on the velocity of displacement of depressions.—M. Bridel and G. Charoux: Centaureidine, a product obtained from centaureine, a glucoside from the roots of *Centaurea Jacea*. This substance, which has the composition of  $C_{16}H_{16}O_8$ , is probably a derivative of flavone.—M. Aynaud: Botrymycosis of sheep.

## SYDNEY.

Royal Society of New South Wales, November 1.—Mr. C. A. Sussmilch, president, in the chair.—R. S. Hughesdon, H. G. Smith, and J. Read: The stereo-isomeric forms of menthone. The ten stereoisomeric forms of  $\beta$ -menthan-3-one stated to be theoretically possible, and certain menthones and menthols derived by reduction from the optically active and inactive forms of piperitone are discussed.—E. Hurst, H. G. Smith, and J. Read: A contribution to the chemistry of the phellandrenes. Muta-rotation and optical inversion on the part of *l*-phellandrene  $\alpha$ -nitrite occurs when it is dissolved in chloroform, benzene, or acetone, and maintained at  $20^\circ C$ .—H. G. Smith: Notes on the chemistry of certain Australian plant products. Pt. i. A resin coating the leaves and stems of *Acacia verniciflua*, the essential oil of the small leaved *Beechia Gunniana*, and the rubber and gum from *Sarcostemma australe*, are discussed. The milky latex of *Sarcostemma australe* contains about 7 per

cent. of rubber, together with resin.—E. H. Booth: Notes on the photographic work of the Sydney University Eclipse Expedition, Goondiwindi, Queensland. The principle adopted was to give full exposures to ensure recording all required material on the plate, to develop to the point of general chemical fog, and to take from each plate a series of prints of different exposures, thus enabling a complete analysis of every degree of density in each plate to be made. This has the same value as a large number of individual exposures. The process appears to have been quite successful, giving a full range of prints showing detail from the extreme photographic limit of the outer corona into the prominences. An outline of exposures and subsequent photographic treatment is given. Photographs showing inner corona and prominences were displayed.—A. R. Penfold: The essential oils of two Myrtaceous shrubs, *Homoranthus virgatus* and *H. flavescens*. The shrubs are common to various parts of Northern New South Wales and Queensland. *H. virgatus* contains as principal constituent up to 80 per cent. dextro alpha pinene, sesquiterpene, amyl alcohol, and esters, and a paraffin of M.P. 65-66° C. *H. flavescens* contains 80 per cent. of the olefinic terpene "Ocimene," together with dextro alpha pinene, sesquiterpene, amyl alcohol, etc. This hydrocarbon is recorded for the first time in an Australian essential oil.—F. R. Morrison: The essential oil of *Kunzea coriifolia*. This dark green bushy shrub, which is one of the commonest growing in the Port Jackson district, yields a light brown mobile oil of fragrant odour. The oil consists principally of dextro alpha pinene, a sesquiterpene closely resembling cadinene, an unidentified alcohol (the odoriferous constituent), and small quantities of acetic and butyric acid esters.—W. M. Doherty: A note on the food value of the snapper (*Pagrosomus auratus*). The percentage of fat in the snapper is very small, but it gave indication of the presence of the fat-soluble, growth-promoting factor, vitamin A.

### Official Publications Received.

Report of the Department of Naval Service for the Year ended March 31, 1922. (Sessional Paper No. 17a—A. 1923.) Pp. 54. (Ottawa.)

Ministerio da Agricultura, Industria e Commercio: Directoria de Meteorologia. Boletim Meteorologico: Anno de 1916. Pp. vi+130. (Rio de Janeiro.)

The Indian Forest Records. Vol. 9, Part 4. The Constituents of some Indian Essential Oils. Parts 1-7. By J. L. Simonsen and Madyar Gokul Rau. Pp. 36. (Calcutta: Government Printing Office.) 6 annas.

Forest Bulletin, No. 49: Note on Thinzaon (*Hopca olerata*, Roxb.). By A. Rodger. Pp. 15. 7 annas. Forest Bulletin, No. 50: Note on Gurjun or Kanyin. Compiled by W. Robertson. Pp. 7. 4 annas. (Calcutta: Government Printing Office.)

Union of South Africa. Fisheries and Marine Biological Survey. Report No. 2 for the Year 1921, by Dr. J. D. F. Gilchrist: with Introduction by H. Warington Smyth; and Special Reports 1: Heterosomata (Flat Fishes), by C. Von Bonde; 2: Physical and Chemical Observations, by Dr. C. Juritz; 3: Deep-sea Fishes (Part 1), by Dr. J. D. F. Gilchrist. Pp. iv+84+79+12 plates. (Cape Town.)

Transactions of the Leicester Literary and Philosophical Society, together with the Report of the Council for 1921-22, and Annual Reports of the Sections. Vol. 23, 1922. Pp. 74. (Leicester.)

The Annual Report of the Gresham's School Natural History Society, 1922. Pp. 12. (Holt, Norfolk.)

Department of Agriculture and Natural Resources: Weather Bureau, Annual Report of the Weather Bureau. Part 1: Work of the Weather Bureau during the Calendar Year 1919; Part 2: Meteorological Observations made at the Central Observatory of Manila during the Calendar Year 1919. Pp. 143. (Manila: Bureau of Printing.)

### Diary of Societies.

SATURDAY, DECEMBER 30.

ROYAL INSTITUTION OF GREAT BRITAIN, at 3.—Prof. H. H. Turner: Six Steps up the Ladder to the Stars (2). The Discovery of the Planet Neptune (Juvenile Lectures).

NO. 2774, VOL. 110]

MONDAY, JANUARY 1.

BRITISH PSYCHOLOGICAL SOCIETY (Education Section) (at University College), at 2.30.—Dr. C. W. Kimmins: The Child and the Cinema. ROYAL GEOGRAPHICAL SOCIETY (at Eolian Hall), at 3.30.—Lt.-Comm. A. S. Elwell-Sutton: Up the Tigris (Christmas Lecture to Young People).

CHILD-STUDY SOCIETY (at Royal Sanitary Institute), at 5.—Miss M. Drummond: Children's Drawings.

MATHEMATICAL ASSOCIATION (at London Day Training College), at 5.30.—Dr. S. Brodetsky: Gliding.

NATIONAL LEAGUE FOR HEALTH, MATERNITY, AND CHILD WELFARE (at University College), at 5.30.—Health Problems of Adolescence.

TUESDAY, JANUARY 2.

MATHEMATICAL ASSOCIATION (at London Day Training College), at 10.—Prof. E. H. Neville: A Statement respecting the forthcoming Report of the Sub-Committee on the teaching of Geometry.—At 11.—W. C. Fletcher: The Uses of Non-Euclidean Geometry to Teachers.—At 12.—Prof. K. W. Gense: Simple Geometrical and Kinematical Illustrations of the Plane Complex.—J. Brill: A certain Dissection Problem.—At 2.30.—Sir Thomas L. Heath: Greek Geometry, with special reference to Infinitesimals (President's Address).—Prof. A. Lodge: Differentials as the basis for teaching the Calculus.

ROYAL INSTITUTION OF GREAT BRITAIN, at 3.—Prof. H. H. Turner: Six Steps up the Ladder to the Stars (3). Photographing the Stars (Juvenile Lectures).

NATIONAL LEAGUE FOR HEALTH, MATERNITY, AND CHILD WELFARE (at University College), at 5.30.—Dr. J. Kerr: Physique and Growth.

ROYAL PHOTOGRAPHIC SOCIETY OF GREAT BRITAIN (Scientific and Technical Group), at 7.—H. Lamplough: The Lamplough Flash Lamp.—A. C. Hanfield: A Demonstration of the German Aeroplane Projector now in the Society's Museum.

RÖNTGEN SOCIETY (at Institution of Electrical Engineers), at 8.15.—Dr. A. E. Barclay: The Organisation and Equipment of a Modern X-Ray Department with special reference to the New Department at the Manchester Royal Infirmary.—Major C. E. S. Phillips: An Electroscope of New Design.

WEDNESDAY, JANUARY 3.

ROYAL SOCIETY OF ARTS, at 3.—C. R. Darling: The Spectrum, its Colours, Lines, and Invisible Parts, and some of its Industrial Applications (Dr. Mann Juvenile Lecture).

PHYSICAL SOCIETY OF LONDON AND OPTICAL SOCIETY (at Imperial College of Science and Technology), at 3-6, and 7-10.—Annual Exhibition of Scientific Apparatus.—At 4.—W. Gamble: Reproduction of Colour by Photographic Processes.—At 8.—Prof. E. G. Coker: Recent Researches on Engineering Problems. ROYAL MICROSCOPICAL SOCIETY (Biological Section), at 7.30.

THURSDAY, JANUARY 4.

GEOGRAPHICAL ASSOCIATION (at Birkbeck College), at 12.—Sir John Russell: The Influence of Geographical Factors in the Agricultural Activities of a Population (Presidential Address).—At 2.30.—J. Fairgrieve: Report on his Recent Visit to the United States.—At 5.—H. Batsford: Types and Materials of Houses in England.

ROYAL INSTITUTION OF GREAT BRITAIN, at 3.—Prof. H. H. Turner: Six Steps up the Ladder to the Stars (4). The Spectroscope and its Revelations (Juvenile Lectures).

PHYSICAL SOCIETY OF LONDON AND OPTICAL SOCIETY (at Imperial College of Science and Technology), at 3-6, and 7-10.—Annual Exhibition of Scientific Apparatus.—At 4.—Prof. E. G. Coker: Recent Photo-Elastic Researches on Engineering Problems.—At 8.—W. Gamble: Reproduction of Colour by Photographic Processes.

INCORPORATED BRITISH ASSOCIATION FOR PHYSICAL TRAINING (at University College), at 5.—Prof. M. E. DeLafield: Hygiene as applied to Physical Training.

ROYAL AERONAUTICAL SOCIETY (at Royal Society of Arts), at 5.30.—H. Junkers: Metal Aeroplanes.

NATIONAL LEAGUE FOR HEALTH, MATERNITY, AND CHILD WELFARE (at University College), at 5.30.—Dr. W. Brown: Child Psychology and Psychotherapy.

INSTITUTION OF ELECTRICAL ENGINEERS, at 6.—F. Creedy: Variable-speed A.C. Motors without Converters. CAMBRIDGE CLUB, at 8.15.—W. L. F. Wastell: The Evolution of the Lantern Slide.

FRIDAY, JANUARY 5.

GEOGRAPHICAL ASSOCIATION (at Birkbeck College), at 10.—Dr. Olive Wheeler: The Place of Geography in the Education of the Adolescent.—At 11.45.—Maj.-Gen. Lord Edwin Gleichen: Permanent Committee on Geographical Names.—At 12.15.—Prof. W. S. Tower: Geography and Business Life.—At 2.30.—E. E. Lupton and others: Discussion on ways of increasing the Usefulness of Branches of the Association.—At 5.—Prof. P. M. Roxby: The Coming Industrialisation of China.

ROYAL GEOGRAPHICAL SOCIETY (at Eolian Hall), at 3.30.—R. E. Priestley: Antarctic Adventures (Christmas Lecture to Young People).

NATIONAL LEAGUE FOR HEALTH, MATERNITY, AND CHILD WELFARE (at University College), at 5.30.—Prof. H. R. Kenwood: Health Education.

JUNIOR INSTITUTION OF ENGINEERS, at 7.30.—W. Dinwoodey: Wave Power Transmission.

SATURDAY, JANUARY 6.

ASSOCIATION OF WOMEN SCIENCE TEACHERS (at University College), at 2.30.—Dr. Dorothy Which: Relativity.

ROYAL INSTITUTION OF GREAT BRITAIN, at 3.—Prof. H. H. Turner: Six Steps up the Ladder to the Stars (5). Two Great Streams of Stars (Juvenile Lectures).

GILBERT WHITE FELLOWSHIP (at 6 Queen Square, W.C.1), at 3.—G. J. B. Fox: A Visit to Pompeii.

## Recent Scientific and Technical Books

Volumes marked with an asterisk have been received at "NATURE" Office.

## Mathematics

- Beckett, T. A., and Robinson, F. E.** Plane Geometry for Schools. Gl. 8vo. Part 2. Pp. viii+241+453+V. (London: Kingivtons, 1922.) 5s.
- Burns, P. F.** Reason-Why Arithmetic Course. Large Cr. 8vo. Book 1. Pp. 64. Paper, 6d.; Cloth, 8d. Book 2. Pp. 80. Paper, 7d.; Cloth, 9d. Book 3. Pp. 80. Paper, 7d.; Cloth, 9d. (London and Glasgow: W. Collins, Sons and Co., 1922.)
- Few, H. P.** Elementary Determinants for Electrical Engineers. Cr. 8vo. Pp. vi+98. (London: S. Rentell and Co., Ltd.; New York: D. Van Nostrand Co., 1922.) 4s. net.\*
- Griffin, F. L.** An Introduction to Mathematical Analysis. Cr. 8vo. Pp. 535. (London: G. G. Harrap and Co., Ltd., 1922.) 10s. 6d. net.
- London Mathematical Society.** Proceedings of the Second Series. Vol. 20. Sup. Roy. 8vo. Pp. liv+502. (London: F. Hodgson, 1922.)\*
- Murdoch, W. H. F.** Mathematical Synopsis: Algebra, Logarithms, Trigonometry and Spherical Trigonometry. 32mo. Pp. 42. (London: Bowman and Murdoch, 1922.) 2s. 6d. net.
- Phillips, H. B.** Differential Equations. Cr. 8vo. Pp. 78. (New York: J. Wiley and Sons, Inc.; London: Chapman and Hall, Ltd., 1922.) 6s. 6d. net.
- Shireby, R. M.** The Slide Rule applied to Commercial Calculations. Cr. 8vo. Pp. 72. (London: Sir I. Pitman and Sons, Ltd., 1922.) 2s. 6d. net.
- Turner, J.** Practical Mathematics: Problems and Questions. Gl. 8vo. Pp. 80+x. (London and Edinburgh: McDougall's Educational Co., Ltd., 1922.) 1s. 9d.
- Youngson, P., and Shaw, J. H.** Practical Mathematics. Cr. 8vo. Pp. 500. (Glasgow: J. Munro and Co., Ltd., 1922.) 10s. 6d. net.

## Mechanics: Mechanical Engineering

- Brownlie, D.** Boiler Plant Testing: A Criticism of the Present Boiler Testing Code and Suggestions for an Improved International Code. Demy 8vo. Pp. xi+168. (London: Chapman and Hall, Ltd., 1922.) 10s. 6d. net.\*
- Burgess, G. K., and Woodward, R. W.** Thermal Stresses in Chilled Iron Car Wheels. (Department of Commerce. Technologic Papers of the Bureau of Standards, No. 209.) Sup. Roy. 8vo. Pp. 193-232. (Washington: Government Printing Office, 1922.) 5 cents.\*
- Croft, T.** Steam Power Plant Auxiliaries and Accessories. Demy 8vo. Pp. xv+447. (New York and London: McGraw-Hill Book Co., Inc., 1922.) 15s. net.\*
- Goldingham, A. H.** The Design and Construction of Oil Engines. Fifth edition. Cr. 8vo. Pp. 426. (London: E. and F. N. Spon, Ltd., 1922.) 20s. net.
- Goudie, Prof. W. J.** Steam Turbines. Second edition, rewritten and enlarged. Demy 8vo. Pp. xviii+804. (London: Longmans, Green and Co., 1922.) 30s. net.\*
- Snodgrass, J. M., and Guldner, F. H.** An Investigation of the Properties of Chilled Iron Car Wheels. Part I: Wheel Fit and Static Load Strains and Stresses. Conducted by the Engineering Experiment Station, University of Illinois, in co-operation with the Association of Manufacturers of Chilled Iron Car Wheels. (University of Illinois Engineering Experiment Station. Bulletin No. 129.) Med. 8vo. Pp. 103. (Urbana: University of Illinois; London: Chapman and Hall, Ltd., 1922.) 5s. cents.\*
- Viall, E.** Les Broches à mandriner et le mandrinage à la Broche. Traduit de l'Américain par Maurice Varioin. Roy. 8vo. Pp. xii+218. (Paris: Libr. Dunod, 1922.) 28 francs.

## Physics: Electrical Engineering

- Avery, A. H.** Dynamo Design and Construction. (Cassell's Workshop Series.) Ex. Cr. 8vo. Pp. 264. (London: Cassell and Co., Ltd., 1922.) 6s. net.

- Bloch, Dr. L.** Le Principe de la relativité et la théorie d'Einstein. (Bibliothèque des Annales des Postes, Télégraphes et Téléphones.) Demy 8vo. Pp. iii+42. (Paris: Gauthier-Villars et Cie, 1922.) 3-50 francs.\*
- Chauveau, B.** Électricité atmosphérique. Premier fascicule: Introduction historique. Roy. 8vo. Pp. xi+90. (Paris: G. Doin, 1922.) 10 francs.\*
- Claude, G.** L'Électricité à la portée de tout le monde. 8e édition. Nouveau tirage. Roy. 8vo. Pp. 519. (Paris: Libr. Dunod, 1922.) 19-50 francs.
- Coursey, P. R.** The Radio Experimenter's Handbook. Roy. 8vo. Pp. vi+113. (London: Wireless Press, Ltd., 1922.) 3s. 6d. net.
- Cross, H. H. U.** Automobile Batteries. New impression. Cr. 8vo. Pp. 109. (London: E. and F. N. Spon, Ltd., 1922.) 2s. 6d. net.
- Curchod, A.** Installations électriques de force et lumière: Schémas de connexions. 4e édition. Nouveau tirage. Roy. 8vo. Pp. viii+278. (Paris: Libr. Dunod, 1922.) 18-50 francs.
- Douglas, A. L. M.** The Construction of Amateur Valve Stations. Cr. 8vo. Pp. 81. (London: Wireless Press, Ltd., 1922.) 1s. 6d. net.
- Dover, A. T.** Industrial Motor Control: Direct Current. Dealing with the Principles involved in the Starting and Speed Control of D.C. Motors for Industrial Services, and with the Applications of these Principles to Typical Control Apparatus, with many Examples from Practice. (Pitman's Technical Primer Series.) Pott 8vo. Pp. xi+116. (London: Sir I. Pitman and Sons, Ltd., 1922.) 2s. 6d. net.\*
- Du Pasquier, Prof. L.-G.** Le Principe de la relativité et les théories d'Einstein. Cr. 8vo. Pp. xvi+511. (Paris: G. Doin, 1922.) 18 francs net.\*
- Eddington, Prof. A. S.** The Romanes Lecture, 1922. The Theory of Relativity and its Influence on Scientific Thought. Delivered in the Sheldonian Theatre, May 24, 1922. Demy 8vo. Pp. 32. (Oxford: Clarendon Press, 1922.) 2s. net.\*
- Eichhorn, Dr. G.** Drahtloser Übersee-Verkehr. 4to. Pp. 49+xx. (Zürich: Beer et Cie, 1921.) 7 francs.\*
- Einstein, Prof. A.** Sidelights on Relativity. I. Ether and Relativity. II. Geometry and Experience. Translated by Dr. G. B. Jeffery and Dr. W. Perrett. Cr. 8vo. Pp. iv+56. (London: Methuen and Co., Ltd., 1922.) 3s. 6d. net.\*
- Gillon, Prof. G.** Cours de constructions électromécaniques. Album de plans et croquis de machines électriques. Album de 38 grandes planches 27x40, 4e édition. (Paris: Libr. Dunod, 1922.) 40 francs.
- Johnson, V. E.** Modern High-speed Influence Machines. New impression. 8vo. Pp. 285. (London: E. and F. N. Spon, Ltd., 1922.) 12s. 6d. net.
- Kemp, P.** Alternating Current Electrical Engineering. Demy 8vo. Pp. xi+515. (London: Macmillan and Co., Ltd., 1922.) 17s. net.\*
- Michaud, F.** Rayonnement et Gravitation. Roy. 8vo. Pp. viii+62. (Paris: Gauthier-Villars et Cie, 1922.) 6 francs.\*
- Mills, J.** Within the Atom: A Popular View of Electrons and Quanta. Cr. 8vo. Pp. xiii+215. (London: G. Routledge and Sons, Ltd., 1922.) 6s. net.\*
- Neumann, Prof. E. R.** Vorlesungen zur Einführung in die Relativitätstheorie. (Jena: G. Fischer, 1922.) 90 marks.
- Ollivier, Prof. H.** Cours de physique générale à l'usage des candidats au certificat de physique générale, au diplôme d'ingénieur-électricien et à l'agrégation des sciences physiques. Tome Second: Thermodynamique et étude de l'énergie rayonnante. Deuxième édition, entièrement refondue. Roy. 8vo. Pp. 415. (Paris: J. Hermann, 1922.) 28 francs net.\*
- Poole, H. E.** Switching and Switchgear: An Introductory Treatment of the Principles of Switching in Electric Circuits; The Design of Switchgear, Switchboards, and Auxiliary Apparatus, with Notes on Practical Applications. (Pitman's Technical Primer Series.) Pott 8vo.

Pp. ix+118. (London: Sir I. Pitman and Sons, Ltd., 1922.) 2s. 6d. net.\*

**Smith, Dr. C. F.** The Testing of Transformers and Alternating Current Machines: the Main Principles and Practice of Efficiency and Output Tests on A.C. Transformers, Alternators, and Motors, with Examples from Practice, for Students and Engineers. (Pitman's Technical Primer Series.) Pott 8vo. Pp. xi+91. (London: Sir I. Pitman and Sons, Ltd., 1922.) 2s. 6d. net.\*

**Soubrier, Prof. M.** Précis d'électricité industrielle; les appareils à courant alternatif: Leçons professées à l'École supérieure de Mécanique. Ex. Cr. 8vo. Pp. iv+152. (Paris: Libr. Dunod, 1922.) 12 francs.

**Sternberg, L.-A.** Manuel pratique de l'ouvrier électricien-mécanicien. Nouvelle traduction et adaptation française de l'ouvrage d'E. Schulz. Ex. Cr. 8vo. Pp. xiv+306. (Paris: Libr. Dunod, 1922.) 12 francs.

**Taggart, J. S.** Wireless for All: a Simple Explanation of Wireless for the General Public. 8vo. Pp. 76. (London: *The Daily Express*, 1922.) 6d. net.

**Timbie, Prof. W. H., and Bush, Prof. V.** Principles of Electrical Engineering. Ex. Cr. 8vo. Pp. viii+513. (New York: J. Wiley and Sons, Inc.; London: Chapman and Hall, Ltd., 1922.) 20s. net.\*

**Verrill, A. H.** The Home Radio: How to Make and Use It. 18mo. Pp. 113. (London: Harper Bros., 1922.) 3s. 6d. net.

## Chemistry

**Arendt, R.** Leitfaden für den Unterricht in der Chemie und Mineralogie. 15 Auflage. Bearbeitet von Prof. Dr. L. Doermmer. Pp. vi+154. (Leipzig: L. Voss, 1922.) 30 marks.

**Bernthsen, Dr. A.** A Textbook of Organic Chemistry. New edition, revised to date by Prof. J. J. Sudborough. Cr. 8vo. Pp. xvi+908. (London and Glasgow: Blackie and Son, Ltd., 1922.) 12s. 6d. net.\*

**Chamberlain, Prof. J. S.** A Textbook of Organic Chemistry. Cr. 8vo. Pp. xliii+959. (London: G. Routledge and Sons, Ltd., 1922.) 16s. net.\*

**Fenton, Dr. H. J. H.** Notes on Qualitative Analysis; Concise and Explanatory. Supplement. Cr. 4to. Pp. v+155-202. (Cambridge: At the University Press, 1922.) 3s. 6d. net.\*

**Friend, Dr. J. N.** The Corrosion of Iron. (Iron and Steel Institute. Carnegie Scholarship Memoirs, Vol. xi.) Edited by George C. Lloyd. Demy 8vo. Pp. vi+161. (London: The Institute; E. and F. N. Spon, Ltd.; New York: Spon and Chamberlain, 1922.) 10s. net.\*

**Ibbotson, F., and Aitchison, L.** The Analysis of Non-Ferrous Alloys. Second edition. Demy 8vo. Pp. ix+246. (London: Longmans, Green and Co., 1922.) 12s. 6d. net.\*

**Johnston, G. L.** Photography in Colours. Fourth edition, revised and enlarged. Cr. 8vo. Pp. xv+318. (London: G. Routledge and Sons, Ltd., 1922.) 7s. 6d. net.

**Kempton, P. H. S.** Industrial Nitrogen: The Principles and Methods of Nitrogen Fixation and the Industrial Applications of Nitrogen Products in the Manufacture of Explosives, Fertilisers, Dyes, etc. (Pitman's Technical Primer Series.) Pott 8vo. Pp. xii+104. (London: Sir I. Pitman and Sons, Ltd., 1922.) 2s. 6d. net.\*

**Russell, Dr. A. S.** An Introduction to the Chemistry of Radio-active Substances. Cr. 8vo. Pp. xi+173. (London: J. Murray, 1922.) 6s. net.\*

## Technology

**Arms, R. W.** The Ignition Temperature of Coal. (University of Illinois Engineering Experiment Station Bulletin No. 128.) Med. 8vo. Pp. 69. (Urbana: University of Illinois; London: Chapman and Hall, Ltd., 1922.) 3s. 6d. net.\*

**Barker, A. F.** Textiles. With chapters on the Mercerized and Artificial Fibres, and the Dyeing of Textile Materials, by W. M. Gardner; Silk Throwing and Spinning,

by R. Snow; The Cotton Industry, by W. H. Cook; The Linen Industry, by F. Bradbury. (Westminster Series.) Revised edition. Demy 8vo. Pp. xii+386. (London: Constable and Co., Ltd., 1922.) 15s.\*

**Best, W. N.** Burning Liquid Fuel. New edition, revised and enlarged. Roy. 8vo. Pp. 341. (London: E. and F. N. Spon, Ltd., 1922.) 25s. net.

**Clarke, A.** Coal-Tar Colours in the Decorative Industries. Cr. 8vo. Pp. xiii+166. (London: Constable and Co., Ltd., 1922.) 6s.\*

**Davis, W. E.** Quantities and Quantity Taking. Fifth edition, revised. Cr. 8vo. Pp. vii+168. (London: Sir I. Pitman and Sons, Ltd., 1922.) 6s. net.

**Desch, Prof. C. H.** Metallography. (Text-Books of Physical Chemistry.) Third edition. Cr. 8vo. Pp. xi+440. (London: Longmans, Green and Co., 1922.) 16s. net.\*

**Fabre, Prof. L.** La Séparation industrielle des isolés en milieu liquide. Roy. 8vo. Pp. v+227. (Paris: G. Doin, 1922.) 16 francs.\*

**Fay, P.** Guide du traceur-mécanicien à l'usage des ouvriers, contremaîtres, chefs d'ateliers, dessinateurs, etc. 11e édition. Demy 8vo. Pp. vii+325+22 planches. (Paris: Libr. Dunod, 1922.) 16 francs.

**Hadfield, Sir R. A.** The Metallurgy of Iron and Steel: An Outline of the Development of Modern Practice in the Metallurgy of Iron and Steel, and its Bearing on the Conservation of Metal and Fuel. Based mainly on the Work and Papers of Sir Robert A. Hadfield. Compiled by the Editor of Pitman's Technical Primers. (Pitman's Technical Primer Series.) Pott 8vo. Pp. xv+122. (London: Sir I. Pitman and Sons, Ltd., 1922.) 2s. 6d. net.\*

**Hurst, G. H.** A Manual of Painters' Colours, Oils, and Varnishes: for Students and Practical Men. Sixth edition, revised by Noel Heaton. Cr. 8vo. Pp. 540. (London: C. Griffin and Co., Ltd., 1922.) 12s. 6d. net.

**Keghel, M. de.** Les Encres, les cirages, les colles et leur préparation. (Bibliothèque Professionnelle.) Pott 8vo. Pp. 384. (Paris: J.-B. Baillière et Fils, 1922.) 10 francs.\*

**Macey, F. W.** Specifications in Detail. Third edition, revised and enlarged by J. P. Allen. Roy. 8vo. Pp. 642. (London: C. Lockwood and Son, 1922.) 30s. net.

**Peel, R.** An Elementary Text-Book of Coal Mining: A Class-Book for Elementary Students preparing for the Board of Education Examination in "Principles of Mining" and for Colliery Managers' Examinations. Revised and enlarged by Prof. D. Burns. Twentieth edition. Fcap. 8vo. Pp. viii+420. (London and Glasgow: Blackie and Son, Ltd., 1921.) 6s. net.\*

**Rubigny, F.** Manuel de filature. (Bibliothèque Professionnelle.) Pott 8vo. Pp. 366. (Paris: J.-B. Baillière et Fils, 1922.) 10 francs.\*

**Scientific and Industrial Research.** Department of: Building Research Board. Special Report No. 5. Building in Cob and Pisé de Terre: A Collection of Notes from various Sources on the Construction of Earth Walls. Med. 8vo. Pp. iv+40. (London: H.M. Stationery Office, 1922.) 2s. net.\*

**Scientific and Industrial Research.** Department of: Report of the Fuel Research Board for the Years 1920, 1921. Second Section: Low Temperature Carbonisation. Med. 8vo. Pp. iv+73+8 plates. (London: H.M. Stationery Office, 1922.) 2s. net.\*

**Wainwright, W. H.** A Graphical Cost Analysis of Cottage-Building. (Department of Scientific and Industrial Research: Building Research Board. Special Report No. 6.) Med. 8vo. Pp. iv+8+20 diagrams. (London: H.M. Stationery Office, 1922.) 2s. 6d. net.\*

**Williams, G. B.** Elementary Sanitary Engineering in India. Second edition. 8vo. Pp. 124. (London: W. Thacker and Co., 1922.) 9s. net.

## Astronomy

**Bigelow, Prof. F. H.** Supplement No. 3 to the *Tyccatases on the Atmospheres of the Sun and the Earth: The Vacuum-Pyreheliometer and the Solar-Radiation.* Med. 8vo. Pp. vi+40. (Printed in Vienna, 1922.)\*

- Doublet, E.** Histoire de l'astronomie. (Encyclopédie scientifique.) Gl. 8vo. Pp. 572. (Paris: G. Doin, 1922.) 17 francs.\*
- Hawkins, Mrs. H. P.** Astronomy for Busy People. 18mo. Pp. 135. (London: Simpkin, Marshall and Co., Ltd., 1922.) 3s. 6d. net.
- Mallik, Prof. D. N.** The Elements of Astronomy. Demy 8vo. Pp. viii + 233. (Cambridge: At the University Press, 1921.) 14s. net.\*

### Geology

- Cadell, H. M.** The Geology of the Blackness District, as disclosed by Recent Borings. (Transactions of the Royal Society of Edinburgh, Vol. 53, Part 1, No. 9.) Roy. 4to. Pp. 189-207. (Edinburgh: R. Grant and Son; London: Williams and Norgate, 1922.) 3s.\*
- Mitchell, G. J.** Scientific Survey of Porto Rico and the Virgin Islands. Vol. 1, Part 3: Geology of the Ponce District. Med. 8vo. Pp. 229-300. (New York: Academy of Sciences, 1922.)\*
- Pascoe, Dr. E. H.** Geological Notes on Mesopotamia, with special reference to Occurrences of Petroleum. (Memoirs of the Geological Survey of India, Vol. 48.) Sup. Roy. 8vo. Pp. vii + 90 + 10 plates. (Calcutta: Geological Survey, 1922.) 5 rupees.\*
- Stiny, Prof. Dr. J.** Technische Geologie. 8vo. Pp. xii + 789. (Stuttgart: F. Enke, 1922.) 270 marks.
- Wilson, R. C.** The Geology of the Western Railway. Section 1: Iddo to Okuku. (Geological Survey of Nigeria. Bulletin No. 2.) With Notes by A. D. N. Bain and W. Russ. Post 4to. Pp. 63 + 9 plates + 1 map. (London: Crown Agents for the Colonies, 4 Millbank, 1922.) 17s. 6d.\*

### Geography: Travel

- Andrews, A. W.** A Text-Book of Geography. Second edition, revised. Cr. 8vo. Pp. xiii + 655. (London: E. Arnold and Co., 1922.) 7s. 6d. net.
- Barclay, W.** Banfshire. (Cambridge County Geographies.) Gl. 8vo. Pp. viii + 139. (Cambridge: At the University Press, 1922.) 3s. 6d.\*
- Bartholomew's** Chart of the World. Six feet by four feet. (Edinburgh: J. Bartholomew and Sons, 1922.) Rollers. 2l. 2s.; dissected on cloth, 30s.
- Bell, A. F. G.** Spanish Galicia. Cr. 8vo. Pp. ix + 200. (London: J. Lane, 1922.) 7s. 6d. net.
- Blacker, L. V. S.** On Secret Patrol in High Asia. 8vo. Pp. xiv + 302. (London: J. Murray, 1922.) 18s. net.
- Bosworth, G. F.** Cambridge Geographical Text-Books: Senior. Cr. 8vo. Pp. xiv + 507. (Cambridge: At the University Press, 1922.) 7s. 6d.\*
- Chambers's** Geographical Readers of the Continents. Africa. New edition, revised to date. Cr. 8vo. Pp. 224. (London: W. and R. Chambers, Ltd., 1922.) 2s.
- Chauvelot, R.** Mysterious India: its Rajahs, its Brahmins, its Fakirs. Translated by Eleanor S. Brooks. 8vo. Pp. x + 277. (London: T. Werner Laurie, Ltd., 1922.) 16s. net.
- Fletcher, G.,** Edited by. Connaught. (The Provinces of Ireland.) Cr. 8vo. Pp. xi + 171. (Cambridge: At the University Press, 1922.) 6s. 6d. net.
- Fletcher, G.,** Edited by. Leinster: East and West. (The Provinces of Ireland.) Cr. 8vo. Pp. xiv + 256. (Cambridge: At the University Press, 1922.) 7s. 6d. net.
- Fletcher, J. S.** Nooks and Corners of Yorkshire. Cheaper edition. Fcap. 8vo. Pp. 304. (London: Eveleigh Nash and Grayson, Ltd., 1922.) 3s. 6d. net.
- Goldring, D.** Nooks and Corners of Sussex and Hampshire. Cheaper edition. Fcap. 8vo. Pp. 253. (London: Eveleigh Nash and Grayson, Ltd., 1922.) 3s. 6d. net.
- Graham, S.** Tramping with a Poet in the Rockies. Ex. Cr. 8vo. Pp. xii + 279. (London: Macmillan and Co., Ltd., 1922.) 8s. 6d. net.\*
- Howarth, E. K.** A Geography of the Bible. Edited by O. J. R. Howarth. Cr. 8vo. Pp. 96. (London: Oxford University Press, 1922.) 2s. net.

- Kermack, W. R.** The Expansion of Britain from the Age of the Discoveries: A Geographical History. Gl. 8vo. Pp. 112. (London: Oxford University Press, 1922.) 2s. 6d. net.\*
- Khoori, A. R.** Cyprus: How to See It. Gl. 8vo. Pp. 67. (Alexandria: Anglo-Egyptian Supply Association, 1922.) 3s.
- MacMunn, N. E., and Coster, G.** Europe: A Regional Geography. Cr. 8vo. Pp. 351. (London: Oxford University Press, 1922.) 4s. 6d. net.
- Moore, P. H.** With Gun and Rod in Canada. 8vo. Pp. xi + 261. (London: J. Cape, 1922.) 12s. 6d. net.
- St.-Johnston, T. R.** South Sea Reminiscences. 8vo. Pp. 213. (London: T. Fisher Unwin, Ltd., 1922.) 16s. net.
- Swiss Travel Almanac:** Summer Season, 1922. Edited by the Swiss Tourist Information Office. Cr. 8vo. Pp. 112. (Olten, Switzerland: Otto Walter, Ltd., 1922.)\*
- Thoulet, Prof. J.** L'Océanographie. (Science et Civilisation. Collection d'exposés synthétiques du savoir humain.) Cr. 8vo. Pp. ix + 287. (Paris: Gauthier-Villars et Cie, 1922.) 9 francs.\*
- Treves, Sir F.** The Lake of Geneva. Roy. 8vo. Pp. xii + 347. (London: Cassell and Co., Ltd., 1922.) 25s. net.
- Van Dyke, J. G.** The Open Spaces: Incidents of Nights and Days under the Blue Sky. Cr. 8vo. Pp. ix + 272. (New York and London: C. Scribner's Sons, 1922.) 9s. net.

### General Biology: Natural History

- Aberhelden, Prof. Dr. E.,** Herausgegeben von. Handbuch der biologischen Arbeitsmethoden. Lieferung 55. Abt. V: Methoden zum Studium der Funktionen der einzelnen Organe des tierischen Organismus, Teil 6, Heft 3. Sinnesorgane: Lichtsinn und Auge. Sup. Roy. 8vo. Pp. 365-462. (Berlin und Wien: Urban und Schwarzenberg, 1922.) 117 marks.\*
- Brunner, J.** Tracks and Tracking. (Outing Hand-Books.) Gl. 8vo. Pp. xii + 219. (New York: The Macmillan Co.; London: Macmillan and Co., Ltd., 1922.) 6s. net.
- Dawson, Major A. J.** Everybody's Dog Book. 8vo. Pp. x + 293. (London: W. Collins, Sons and Co., 1922.) 10s. 6d. net.
- Dunning, E. R.** A Naturalist in the Great Lakes Region. (University of Chicago Nature-Study Series.) Large Cr. 8vo. Pp. xxv + 328. (Chicago, Ill.: University of Chicago Press, 1922.) 3.50 dollars.\*
- Elms, E. F. M.** Our Migrant Birds and How to Know Them. Cr. 8vo. (London: T. Butterworth, Ltd., 1922.) 6s. net.
- Haynes, W.** The Airedale. (Outing Hand-Books.) Gl. 8vo. Pp. 102. (New York: The Macmillan Co.; London: Macmillan and Co., Ltd., 1922.) 4s. 6d. net.
- Haynes, W.** The Bull Terrier. (Outing Hand-Books.) Gl. 8vo. Pp. 113. (New York: The Macmillan Co.; London: Macmillan and Co., Ltd., 1922.) 4s. 6d. net.
- Haynes, W.** Practical Dog-keeping. (Outing Hand-Books.) Gl. 8vo. Pp. 160. (New York: The Macmillan Co.; London: Macmillan and Co., Ltd., 1922.) 6s. net.
- Haynes, W.** Scottish and Irish Terriers. (Outing Hand-Books.) Gl. 8vo. Pp. 142. (New York: The Macmillan Co.; London: Macmillan and Co., Ltd., 1922.) 6s. net.
- Hertwig, Prof. Dr. O.** Das Werden der Organismen. Zur Widerlegung von Darwins Zufallstheorie durch das Gesetz in der Entwicklung. Dritte Auflage. (Jena: G. Fischer, 1922.) 200 marks.
- Hodges, R. H. W.** Sea and Shore Birds and How to Identify Them. (How to Identify Series, No. 16.) Pott 8vo. Pp. 64. (London: The Epworth Press, 1922.) 1s. 6d. net.\*
- Osborn, Prof. H. F.** L'Origine et l'évolution de la vie. Édition française par F. Sartiaux. Pp. 304. (Paris: Masson et Cie, 1922.) 25 francs net.
- Pitt, Frances.** Woodland Creatures: Being some Wild Life Studies. Demy 8vo. Pp. 255. (London: G. Allen and Unwin, Ltd., 1922.) 12s. 6d. net.\*

- Russell, Dr. D.** The Evolution of Continuity in the Natural World. Demy 8vo. Pp. 278. (London: G. Allen and Unwin, Ltd., 1922.) 16s. net.\*
- Seers, H. W.** Nature Stories. Cr. 8vo. Pp. 116. (London: G. G. Harrap and Co., Ltd., 1922.) 1s.
- Swann, H. K.** A Synopsis of the Accipitres (Diurnal Birds of Prey). Part 4. (Alciphierax to Pandion) Comprising Species and Subspecies described up to 1920, with their Characters and Distribution. Second edition, revised and corrected throughout. Med. 8vo. Pp. viii+179-233. (London: Wheldon and Wesley, Ltd., 1922.) 6s.\*

### Botany: Horticulture: Forestry

- Ames, O.** Illustrations and Studies of the Family Orchidaceae, issued from the Ames Botanical Laboratory. Fascicule 6: The Orchids of Mount Kinanulu, British North Borneo; Notes on Philippine Orchids, VII. Roy. 8vo. Pp. 335+22 plates. (London: Wheldon and Wesley, Ltd., 1922.) 50s. net.
- Cook, E. T.,** Edited by. Gardening made Easy. Eighth edition. 8vo. Pp. 215. (London: "Country Life" and G. Newnes, Ltd., 1922.) 2s. 6d.
- Fortey, Isabel C.** Plant Studies in the Tropics. Gl. 8vo. Pp. vi+223. (London and Glasgow: Blackie and Son, Ltd., 1922.) 2s. net.
- Karsten, Prof. Dr. G., and Schenck, Prof. Dr. H.,** Herausgegeben von. Vegetationsbilder. 14 Reihe, Heft 2/3: Mittel-China, von Dr. Heinrich Handel-Mazzetti. (Jena: G. Fischer, 1922.) 80 marks.
- Macself, A. J.** Hardy Perennials. (Home Garden Books.) 8vo. Pp. 219. (London: T. Butterworth, Ltd., 1922.) 7s. 6d.
- Nicolle, M., et Magrou, J.** Les Maladies parasitaires des plantes (Infestation—Infection). Cr. 8vo. Pp. 199. (Paris: Masson et Cie, 1922.) 8 francs.\*
- Pratt, A.** Wild Flowers. 2 vols. Cr. 8vo. Pp. 196; 231. (London: S.P.C.K., 1922.) 10s. net.

### Zoology

- Borley, J. O., and Russell, Dr. E. S.** Report on Herring Trawling, (Fisheries—England and Wales. Ministry of Agriculture and Fisheries. Fishery Investigations: Series 2, Sea Fisheries. Vol. 4, No. 4.) Fcap. folio. Pp. 57. (London: H.M. Stationery Office, 1922.) 7s. 6d. net.\*
- Brachet, Prof. A.** Traité d'embryologie des vertébrés. Pp. 602. (Paris: Masson et Cie, 1922.) 60 francs net.
- Chun, Prof. C.,** Herausgegeben von, und nach seinem Tode fortgesetzt von **A. Brauer, E. Vanhöffen, und C. Apstein.** Wissenschaftliche Ergebnisse der deutschen Tiefsee-Expedition auf dem Dampfer "Valdivia," 1898-1899. XXIII Band, Heft 2: Cirripedia der deutschen Tiefsee-Expedition. Von **Prof. Dr. W. Weltner.** (Jena: G. Fischer, 1922.) 60 marks.
- Fishery Board for Scotland.** Scientific Investigations, 1921. No. 3: Report of the Cephalopoda collected by the "Goldseeker," 1903-1908. (London: H.M. Stationery Office, 1922.) 3s. 6d. net.
- Johansen, F.** Insect Life on the Western Arctic Coast of America. (Report of the Canadian Arctic Expedition, 1913-18. Vol. 3: Insects. Part K.) Roy. 8vo. Pp. 61k. (Ottawa: Department of the Naval Service, 1921.)\*
- Moulton, Major J. C.** Raffles Museum Guide. Mammals of Malaysia. Part 1: Malaysian Ungulates. Demy 8vo. Pp. vi+31+10 plates. (Singapore: Raffles Museum, 1922.) 1 dollar.\*
- Sars, G. O.** An Account of the Crustacea of Norway: with short Descriptions and Figures of all the Species. Vol. 8: Copepoda, Monstrilloida and Notodelphyoidea. Parts 5 and 6: Botryllophoridae, Enterocolidae, Supplement. Imp. 8vo. Pp. 60-91+plates 33-37. (Christiania: Alb. Cammermeyers Forlag, 1921.)\*
- Selbie, C. M.** The Decapoda Reptantia of the Coasts of Ireland. Part 2: Paguridea. (Department of Agriculture and Technical Instruction for Ireland: Fisheries

Branch. Scientific Investigations, 1921, No. 1.) Med. 8vo. Pp. 68+9 plates. (Dublin and London: H.M. Stationery Office, 1921.) 3s. net.\*

### Agriculture

- McCandlish, A. G.** Feeding of Dairy Cattle. 8vo. Pp. 281. (New York: J. Wiley and Sons, Inc.; London: Chapman and Hall, Ltd., 1922.) 12s. 6d. net.
- MacGarr, L.** The Rural Community. Cr. 8vo. Pp. xv+239. (New York: The Macmillan Co.; London: Macmillan and Co., Ltd., 1922.) 8s. net.\*
- Marquand, C. V. B.** Varieties of Oats in Cultivation. (University College of Wales, Aberystwyth. Welsh Plant Breeding Station. Series C, No. 2.) 4to. Pp. 44+7 plates. (Aberystwyth: Agricultural Buildings, 1922.) 5s. 6d.\*
- Pearse, A. S.** Brazilian Cotton: Being the Report of the Journey of the International Cotton Mission through the Cotton States of São Paulo, Minas Geraes, Bahia, Alagoas, Sergipe, Pernambuco, Parahyba, Rio Grande do Norte. Roy. 8vo. Pp. 231. (Manchester: International Federation of Master Cotton Spinners, 525 Royal Exchange, 1922.) 21s.
- Sanders, T. W.** Vegetable Foes. Cr. 8vo. Pp. 109. (London: W. H. and L. Collingridge, 1922.) 4s. net.
- Sanders, T. W.** Fruit Foes. Cr. 8vo. Pp. 106. (London: W. H. and L. Collingridge, 1922.) 4s. net.

### Philosophy: Psychology

- Appleton, R. B.** The Elements of Greek Philosophy: from Thales to Aristotle. Cr. 8vo. Pp. 184. (London: Methuen and Co., Ltd., 1922.) 6s. net.
- Brown, Dr. W.** Suggestion and Mental Analysis: An Outline of the Theory and Practice of the Cure. Cr. 8vo. Pp. 165. (London: University of London Press, Ltd., 1922.) 3s. 6d. net.\*
- Heymans, G.** Einführung in die Ethik auf Grundlage der Erfahrung. 2 Auflage. Pp. viii+322. (Leipzig: J. A. Barth, 1922.) 90 marks.
- Moore, Dr. G. E.** Philosophical Studies. (International Library of Psychology, Philosophy, and Scientific Method.) Demy 8vo. Pp. viii+342. (London: Kegan Paul and Co., Ltd.; New York: Harcourt, Brace and Co., Inc., 1922.) 15s. net.\*
- Prescott, F. C.** The Poetic Mind. Ex. Cr. 8vo. Pp. xx+308. (New York: The Macmillan Co.; London: Macmillan and Co., Ltd., 1922.) 9s. net.\*
- Santayana, G.** Soliloquies in England and Later Soliloquies. Demy 8vo. Pp. viii+264. (London: Constable and Co., Ltd., 1922.) 12s.\*
- Schumann, F.** Psychologische Studien. I Abteilung: Beiträge zur Analyse der Gesichtswahrnehmungen. Heft 6: Untersuchungen über d. Erkennungsvorgang. Pp. iv+292. (Leipzig: J. A. Barth, 1922.) 40 marks.
- Stephen, K.** The Misuse of Mind: A Study of Bergson's Attack on Intellectualism. (International Library of Psychology, Philosophy, and Scientific Method.) Demy 8vo. Pp. 107. (London: Kegan Paul and Co., Ltd.; New York: Harcourt, Brace and Co., Inc., 1922.) 6s. 6d. net.\*
- Walston (Waldstein), Sir C.** Harmonism and Conscious Evolution. Demy 8vo. Pp. xvi+463. (London: J. Murray, 1922.) 21s. net.\*
- Welton, Dr. J.** Groundwork of Ethics. Cr. 8vo. Pp. xv+155. (London: University Tutorial Press, Ltd., 1922.) 3s. 6d.
- Winkler, Dr. H.** Die Monotonie der Arbeit. Pp. 45. (Leipzig: J. A. Barth, 1922.) 12 marks.
- Wulf, M. de.** Philosophy and Civilization in the Middle Ages. Demy 8vo. Pp. x+313. (Princeton: University Press; London: Oxford University Press, 1922.) 12s. 6d. net.

### Bacteriology

- d'Hérelle, F.** Le Bactériophage; son rôle dans l'immunité. Pp. 227. (Paris: Masson et Cie, 1922.) 12 francs net.



## Recent Scientific and Technical Books

Volumes marked with an asterisk have been received at "NATURE" Office.

## Mathematics

**Levy, Prof. P.** Leçons d'Analyse Fonctionnelle Professeurs au Collège de France. (Collection de Monographies sur la Théorie des Fonctions.) Roy. 8vo. Pp. vi+442. (Paris: Gauthier-Villars et Cie, 1922.) 35 francs.\*

**Lister, S.** A First Book of Arithmetic: Answers. Gl. 8vo. Pp. 223-258. (London: Macmillan and Co., Ltd., 1922.) 6d.

**MacLeod, Dr. A.** Introduction à la Géométrie Non-Euclidienne. Demy 8vo. Pp. 433. (Paris: J. Hermann, 1922.) 20 francs.\*

**Manning, Prof. W. A.** Primitive Groups. Part I. (Mathematics and Astronomy, Vol. I., No. 1.) Sup. Roy. 8vo. Pp. 108. (California: Stanford University, 1921.) 1.25 dollars.\*

**Moreux, l'Abbé Th.** Pour comprendre Einstein. Cr. 8vo. Pp. 245. (Paris: G. Doin, 1922.) 7 francs.\*

**Murdock, W. H. F.** Mathematical Synopsis—Algebra, Logarithms, Trigonometry and Spherical Trigonometry. 32mo. Pp. 42. (London: Bowman and Murdock, 1922.) 2s. 6d. net.

**Rugg, H. O., and Clark, J. R.** Fundamentals of High School Mathematics. Cr. 8vo. Pp. 368. (London: G. G. Harrap and Co., Ltd., 1922.) 6s. net.

**Thomas, Dr. T.** Outlines of the Calculus for Science and Engineering Students. Cr. 8vo. Pp. 127. (London: Mills and Boon, Ltd., 1922.) 3s. 6d. net.\*

## Mechanics: Mechanical Engineering

**Aeronautical Research Committee:** Internal Combustion Engine Sub-Committee. Report No. 19: Relationship between Air Temperature and the Power of a Petrol Engine. (London: H.M. Stationery Office, 1922.) 4d. net.

**Aeronautical Research Committee.** Reports and Memoranda. No. 692: French and Italian Aeronautical Practice with particular regard to Airships, 25. 6d. net; No. 761: Experimental Determination of Tailplane Characteristics. 9d. net. (London: H.M. Stationery Office, 1922.)

**Boltzmann, Prof. L.** Vorlesungen über die Prinzipie der Mechanik. I Teil: Enthaltend die Prinzipie, bei denen nicht Ausdrücke nach der Zeit integriert werden, welche Variationen der Koordinaten oder ihrer Ableitungen nach der Zeit enthalten. Dritter Abdruck. Pp. x+241. 7 francs. II Teil: Enthaltend die Wirkungsprinzipie, die Lagrangeschen Gleichungen und deren Anwendungen. Zweite unveränderter Abdruck. Pp. ix+336. II francs. (Leipzig: J. A. Barth, 1922.)

**Fyfe, W. W.** Automatic Pumping and Notes on Water Analysis and Filtration. Edited by J. W. Fyfe. Cr. 8vo. Pp. xii+112. (London: C. Griffin and Co., Ltd., 1922.) 7s. 6d. net.\*

**Gates, P.** Capstan and Automatic Lathes: a Practical Guide to Tool and Machine Setting, and the Manipulation of Jobs. With examples from practice. (Pitman's Technical Primers.) Pott 8vo. Pp. 96. (London: Sir I. Pitman and Son, Ltd., 1922.) 2s. 6d. net.

**Gates, P.** Jigs, Tools, and Fixtures: their Drawing and Design. (Lockwood's Technical Manuals.) Cr. 8vo. Pp. xvi+195. (London: C. Lockwood and Son, 1922.) 8s. 6d. net.

**Goudie, Prof. W. J.** Total Heat Entropy Diagrams and Nomograms for Calculation of Total Heat and Specific Volume of Superheated and Supersaturated Steam from Steam Turbines. Second edition. 8vo. (London: Longmans, Green and Co., 1922.) 2s. 6d. net.

**Jenkins, R. E.** Engineering Notes: the Steam Engine. Fcap. 8vo. Pp. 60. (London: J. M. Ouseley and Son, 1922.) 2s. net.

**Lea, Prof. F. C.** Elementary Hydraulics for Technical Students. Cr. 8vo. Pp. viii+224. (London: E. Arnold and Co., 1922.) 7s. 6d. net.\*

**Lefort, R.** Le Bréviaire de l'Aviateur. Ex. Cr. 8vo. Pp. xi+763+4 planches. (Paris: Libr. Dunod, 1922.) 48 francs.

**Marks, L. S.** The Airplane Engine. Pp. ix+454. (New York and London: McGraw-Hill Book Co., Inc., 1922.) 30s. net.

**Roberts, H. E.** Practical Refrigeration for Marine Engineers. Cr. 8vo. Pp. 87. (Glasgow: J. Munro and Co., Ltd., 1922.) 4s. 6d. net.

**Sothern, J. W. M.** Notes and Sketches on Marine Diesel Oil Engines: A Manual of Marine Oil Engine Practice. Med. 8vo. Pp. ix+382. (Glasgow: J. Munro and Co., Ltd., 1922.) 25s. net.

## Physics: Electrical Engineering

**A Wireless Expert.** Home Radio: a Clear, Concise, and Non-technical Explanation of Wireless Telegraphy and Telephony for the Novice. Cr. 8vo. Pp. 61. (London: The Daily News, 1922.) 6d. net.

**Aeronautical Research Committee:** Internal Combustion Engine Sub-Committee. Report No. 14: Investigations of Certain Spark Gaps for Magnetos. 6d. net; No. 21: Synchronism of the Spark of a Magneto as affected by the Method of Coupling. 6d. net. (London: H.M. Stationery Office, 1922.)

**Bayliss, Sir W. M.** Life and the Laws of Thermodynamics: Being the Twenty-fourth Robert Boyle Lecture delivered before the Junior Scientific Club of the University of Oxford on 7th June, 1922. Med. 8vo. Pp. 12. (London: Oxford University Press, 1922.) 1s. net.\*

**Bell, Dr. L.** The Telescope. Med. 8vo. Pp. ix+287. (London: McGraw-Hill Publishing Co., Ltd., 1922.) 15s. net.\*

**Bingham, Prof. E. C.** Fluidity and Plasticity. Pp. xi+440. (New York and London: McGraw-Hill Book Co., Inc., 1922.) 20s. net.

**Cabaud, R.** Installations Electriques Industrielles: Installation—Entretien—Contrôle. (Bibliothèque Professionnelle.) Pott 8vo. Pp. 333. (Paris: J. B. Baillière et Fils, 1922.) 10 francs net.\*

**Capstick, Dr. J. W.** Sound: An Elementary Text-book for Schools and Colleges. (Cambridge Physical Series.) Second edition. Cr. 8vo. Pp. viii+303. (Cambridge: At the University Press, 1922.) 7s. 6d.\*

**Carter, F. W.** Railway Electric Traction. Demy 8vo. Pp. viii+412. (London: E. Arnold and Co., 1922.) 25s. net.\*

**Chapel, General.** Éther—Électricité—Relativisme. Conférence du 22 Mars 1922 à Paris. (Conservatoire des Arts et Métiers.) Ex. Cr. 8vo. Pp. 40. (Paris: Gauthier-Villars et Cie, 1922.) 2.50 francs.\*

**Dingler, Dr. H.** Relativitätstheorie und Oekonomieprinzip. 8vo. Pp. 70. (Leipzig: S. Hirzel, 1922.) 3s. 6d.

**Donisthorpe, Capt. H. de A.** Wireless at Home: Everybody's Guide to Receiving Wireless News, Concerts, and Messages. Pott 8vo. Pp. 46. (London: P. Marshall and Co., 1922.) 6d. net.

**Greenly, H.** Model Electric Locomotives and Railways: their Details and Practical Construction. (Cassell's "Model" Series.) 8vo. Pp. 312. (London: Cassell and Co., Ltd., 1922.) 6s. net.

**Harris, P. W.** The A.B.C. of Wireless: A Popular Explanation. Gl. 8vo. Pp. 64. (London: Wireless Press Ltd., 1922.) 6d. net.

**Helmholtz, H. von.** Vorlesungen über theoretische Physik. Band I, 1. Abt.: Einleitung zu den Vorlesungen über theoretische Physik. Herausgegeben von Prof. Dr. A. König und Prof. Dr. C. Runge. Zweiter unveränderter Abdruck. Pp. viii+50. 45 marks. Band VI: Vorlesungen über Theorie der Wärme. Herausgegeben von Prof. Dr. F. Richarz. Zweiter, durchgesehener Abdruck. Pp. xii+418. 240 marks. (Leipzig: J. A. Barth, 1922.)

**Hinton, N. P.** Wireless for the Home. Cr. 8vo. Pp. 100. (London: Sir I. Pitman and Sons, Ltd., 1922.) 2s. net.

**Ibbetson, W. S.** Electrical Installation Rules and Tables for Rapid Reference; specially written for the use of Practical Wiremen, Contractors, Engineers, and Architects. Waistcoat Pocket Size. Pp. 66. (London: E. and F. N. Spon, Ltd., 1922.) 1s. 6d. net.

**Mahnkopf, Dr. H.** Die Auflösung der funktentelegraphischen Neuere Zeitsignale durch die Deutsche Seewarte. (Aus dem Archiv der Deutschen Seewarte, XXXIX, Jahrgang 1921, Nr. 2.) Med. 4to. Pp. 38. (Hamburg: Deutsche Seewarte, 1921.)\*

**Main, F. W.** Electric Cables. (Technical Primers.) Pott 8vo. Pp. 111. (London: Sir I. Pitman and Sons, Ltd., 1922.) 2s. 6d. net.

**Page, Prof. L.** An Introduction to Electrodynamics: from the Standpoint of the Electron Theory. Ex. Cr. 8vo. Pp. vi+134. (Boston and London: Ginn and Co., 1922.) 10s. net.\*

**Peters, C. G., and Boyd, H. S.** Interference Methods for Standardizing and Testing Precision Gage Blocks. (Scientific Papers of the Bureau of Standards, No. 436.) Sup. Roy. 8vo. Pp. 677-713. (Washington: Government Printing Office, 1922.) 10 cents.\*

**Spiegelhalter, E. K.** Wireless Valve Receiver Set: How to Make It. A Book for Amateurs on the Actual Construction and Operation of a Practical Valve Receiver Set. Cr. 8vo. Pp. 88. (London: E. and F. N. Spon, Ltd., 1922.) 3s. 6d. net.

**Strasser, Prof. Dr. H.** Die Grundlagen der Einsteinschen Relativitätstheorie: Eine kritische Untersuchung. Med. 8vo. Pp. 110. (Bern: Paul Haupt, 1922.)\*

**Strobel, W.** Beiblätter zu den Annalen der Physik, Register zu Band 31-43 (1907-1919). Pp. viii+653. (Leipzig: J. A. Barth, 1922.) 200 marks.

**Todd, V.** Protective Relays: their Theory, Design, and Practical Operation. Pp. xii+274. (New York and London: McGraw-Hill Book Co., Inc., 1922.) 12s. 6d. net.

**Vinal, G. W., and Altrup, F. W.** Electromotive Force of Cells at Low Temperatures. (Scientific Papers of the Bureau of Standards, No. 434.) Sup. Roy. 8vo. Pp. 627-634. (Washington: Government Printing Office, 1922.) 5 cents.\*

**Whittaker, Prof. E. T.** On the Quantum Mechanism in the Atom. (Proceedings of the Royal Society of Edinburgh, Session 1921-1922. Vol. 42, Part 2, No. 10.) Sup. Roy. 8vo. Pp. 129-142. (Edinburgh: R. Grant and Son; London: Williams and Norgate, 1922.) 1s. 8d.\*

**Whyte, A. G.** The All-Electric Age. Demy 8vo. Pp. xiii+242. (London: Constable and Co., Ltd., 1922.) 7s. 6d. net.\*

## Chemistry

**Boll, Prof. M., et Allard, G.** Cours de Chimie (Métaux et Cations). Ex. Cr. 8vo. Pp. xxiv+352. (Paris: Libr. Dunod, 1922.) 26 francs.

**Gain, Dr. J. G., et Thorpe, Prof. J. F.** Les Matières Colorantes de Synthèse et les Produits Intermédiaires servant à leur Fabrication. Traduit d'après la quatrième édition anglaise par Prof. G. Delmarcel et Dr. M. Drapier. Roy. 8vo. Pp. xxiv+640. (Paris: Libr. Dunod, 1922.) 58 francs.

**Comey, Dr. A. M.** A Dictionary of Chemical Solubilities: Inorganic. Second edition, enlarged and revised by Dr. A. M. Comey and Dr. Dorothy A. Hahn. Demy 8vo. Pp. xix+1141. (New York: The Macmillan Co.; London: Macmillan and Co., Ltd., 1921.) 63s. net.

**Denham, Prof. H. G.** An Inorganic Chemistry. Cr. 8vo. Pp. viii+683. (London: E. Arnold and Co., 1922.) 12s. 6d. net.\*

**Falk, H. G.** Catalytic Action. Med. 8vo. Pp. 172. (New York: Chemical Catalog Co., Inc., 1922.) 2.50 dollars.\*

**Faraday Society.** Catalysis with Special Reference to Newer Theories of Chemical Action: a General Discussion held by the Faraday Society. Med. 8vo. Pp. 545-675. (London: The Faraday Society, 1922.) 9s. net.\*

**Fourneau, E.** Préparation des Médicaments organiques. Med. 8vo. Pp. viii+350. (Paris: J.-B. Baillière et Fils, 1921.) 25 francs.\*

**Jackson, R. F., and Silsbee, Clara G.** The Solubility of Dextrose in Water. (Scientific Papers of the Bureau of Standards, No. 437.) Sup. Roy. 8vo. Pp. 715-724. (Washington: Government Printing Office, 1922.) 5 cents.\*

**Knight, J.** Chemistry. Edited by J. Adams. Cr. 8vo. Pp. 186. (London: Hodder and Stoughton, Ltd., 1922.) 2s. 6d. net.

**Loeb, J.** Proteins and the Theory of Colloidal Behavior. (International Chemical Series.) Ex. Cr. 8vo. Pp. xi+292. (London: McGraw-Hill Publishing Co., Ltd., 1922.) 15s. net.\*

**Martin, Dr. G.,** assisted by **Dickson, J. M., and Christelow, Major J. W.** Modern Chemical Lecture Diagrams, with Uses and Applications fully described. Cr. 8vo. Pp. 88. (London: Sampson Low, Marston and Co., Ltd., 1922.) 3s. 6d. net.\*

**Miller, Prof. E. H.** The Calculations of Analytical Chemistry. Third edition, revised and enlarged. Demy 8vo. Pp. x+201. (New York: The Macmillan Co.; London: Macmillan and Co., Ltd., 1921.) 9s. net.\*

**Parry, E. J.** The Chemistry of Essential Oils and Artificial Perfumes. Vol. 2. Fourth edition, revised and enlarged. Roy. 8vo. Pp. 374. (London: Scott, Greenwood and Son, 1922.) 21s. net.

**Robinson, C. S.** The Elements of Fractional Distillation. Pp. ix+205. (New York and London: McGraw-Hill Book Co., Inc., 1922.) 12s. 6d. net.

**Stark, Dr. J.** Natur der chemischen Valenzkräfte. Large 8vo. Pp. 27. (Leipzig: S. Hirzel, 1922.) 1s. 2d.

## Technology

**Argles, G.,** Edited by. Chemicals and Industrial Materials, with their Commercial Uses. 8vo. (Birmingham: C. Argles, 39 Corporation St., 1922.) 10s. 6d. net.

**Barker, A. H.** Tests on Ranges and Cooking Appliances. (Department of Scientific and Industrial Research. Fuel Research Board: Special Report No. 4.) An Extract from the Report of the Building Materials Research Committee. Cr. 4to. Pp. vi+55+15 figs. (London: H.M. Stationery Office, 1922.) 2s. 6d. net.\*

**Broquetel, A.** Manuel du Fabricant de Jouets. (Bibliothèque Professionnelle.) Pott 8vo. Pp. 298. (Paris: J.-B. Baillière et Fils, 1922.) 10 francs net.\*

**Colpitts, W. H.** A Practical Treatise on the Metals used in Marine Engineering. 8vo. Pp. 211. (Glasgow: J. Munro and Co., Ltd., 1922.) 10s. 6d. net.

**Hofman, Dr. H. O.** Metallurgy of Zinc and Cadmium. Pp. xii+341. (New York and London: McGraw-Hill Book Co., Inc., 1922.) 20s. net.

**Hudson, R. J. H.** Reinforced Concrete: A Practical Handbook for Use in Design and Construction. Demy 8vo. Pp. xxiv+318. (London: Chapman and Hall, Ltd., 1922.) 16s. net.\*

**Lee, H. N.,** and others. The Manufacture of Pulp and Paper: a Text-book of Modern Pulp and Paper Mill Practice. Vol. III. Pp. xii+60. (New York and London: McGraw-Hill Book Co., Inc., 1922.) 25s. net.

**Moore, A. S.** Linen. (Staple Trades and Industries Series.) Demy 8vo. Pp. viii+205. (London: Constable and Co., Ltd., 1922.) 10s. 6d. net.

**Petites Maisons Pittoresques.** Deuxième série. Façades—Intérieurs—Coupes—Plans. Album de 50 Planches (34x26). (Paris: Libr. Dunod, 1922.) 45 francs.

**Pilsworth, E. S.** Process Engraving: Formulas, Equipment and Methods of Working. Cr. 8vo. Pp. xii+168. (New York: The Macmillan Co.; London: Macmillan and Co., Ltd., 1922.) 9s. net.

**Rambaud, P.** Notice Pratique sur les Instruments de Pesage-types (construction, ajustage, vérification) suivie des Modes de Rajustage des Poids en Fonte et en Cuivre et des Lois et Règlements concernant la Fabrication des Instruments de Pesage. 3e édition (revue et corrigée). Roy. 8vo. Pp. viii+182. (Paris: Libr. Dunod, 1922.) 10 francs.

**Rawdon, H. S., and Lorentz, Marjorie G.** Metallographic Etching Reagents. II: For Copper Alloys, Nickel, and the Alpha Alloys of Nickel. (Scientific Papers of the Bureau of Standards, No. 435.) Sup. Roy. 8vo. Pp. 635-676. (Washington: Government Printing Office, 1922.) 15 cents.\*

**Rogers, Dr. A.** Practical Tanning: A Handbook of Modern Practice and Processes as applied in the Manufacture of Leather and Applied Products. Partly based on the Third edition of "Practical Tanning," by Louis A. Fleming. Med. 8vo. Pp. xxv+699. (London: C. Lockwood and Son, 1922.) 45s. net.\*

**Roux-Brahic, J.** Technologie des Minerais complexes. Ateliers modernes de Préparation Mécanique des Minerais. Roy. 8vo. Pp. xii+896. (Paris: Libr. Dunod, 1922.) 90 francs.

**Rudd, J. H.** Practical Cabinet Making and Draughting. Roy. 8vo. Pp. 180. (London: Benn Bros., Ltd., 1922.) 10s. 6d. net.

**Schimpke, Prof. Dr. P.** Technologie der Maschinenbaustoffe. 4. Auflage. 8vo. Pp. 344. (Leipzig: S. Hirzel, 1922.) 7s. 2d.

**Sexton, A. H.** An Elementary Text-book of Metallurgy. (Griffin's Scientific Text-books.) Sixth edition, revised and enlarged by C. O. Bannister. Cr. 8vo. Pp. 319. (London: C. Griffin and Co., Ltd., 1922.) 8s. 6d. net.

**Skinner, W. R.,** Edited by. The Oil and Petroleum Manual, 1922. 8vo. Pp. 360. (London: Oil and Petroleum Manual Office, 1922.) 7s. 6d. net.

**Worker, J. G., and Peebles, T. A.** Mechanical Stokers: including the Theory of Combustion of Coal. Pp. xiii+258. (New York and London: McGraw-Hill Book Co., Inc., 1922.) 15s. net.

### Astronomy

**Bigourdan, G.** Union Astronomique Internationale. Corrections des Signaux Horaires déterminées au Bureau International de l'Heure en 1921. (2e année.) Roy. 8vo. Pp. 80. (Paris: Gauthier-Villars et Cie. 1922.) 3 francs.\*

**Esclangon, E.** Les Preuves Astronomiques de la Relativité. Med. 8vo. Pp. 27. (Paris: Gauthier-Villars et Cie, 1922.) 1s. 3d.\*

**Mulder, Prof. Dr. M. E.** The "Green Ray" or "Green Flash" (*Rayon Vert*) at Rising and Setting of the Sun. Roy. 8vo. Pp. 141. (London: T. Fisher Unwin, Ltd., 1922.) 6s. net.\*

**Størmer, G.** Notes Relatives aux Aurores Boreales. (Geofysiske Publicationer, Vol. 2, No. 8.) Med. 4to. Pp. 15+8 planches. (Kristiania: Grøndahl and Sons, 1922.) 3.00 Kr.\*

**Wolf, Prof. M.** Stereoskopbilder vom Sternhimmel. 2 Serie. 3. Auflage. 12 Bilder (hochglänzend) mit Text in Mappe. (Leipzig: J. A. Barth, 1922.) 10 frs.

### Meteorology

**Dijk, Dr. G. van.** Activity of the Earth's Magnetism and Magnetic Characterisation of Days. (Koninklijk Nederlandsch Meteorologisch Instituut. No. 102. Mededeelingen en Verhandelingen, 27.) Roy. 8vo. Pp. 28+23 tables. (Utrecht: Kemink en Zoon, 1922.) 0.90 F.\*

**Hazard, D. L.** Results of Observations made at the United States Coast and Geodetic Survey Magnetic Observatory at Cheltenham, Md., 1917 and 1918. (Serial No. 170.) Med. 4to. Pp. 117+13 plates. (Washington: Government Printing Office, 1922.) 25 cents.\*

**Hazard, D. L.** Results of Observations made at the United States Coast and Geodetic Survey Magnetic Observatory at Vieques, P.R., 1917 and 1918. (Serial No. 168.) Med. 4to. Pp. 104+15 plates. (Washington: Government Printing Office, 1922.) 25 cents.\*

**Kendrew, W. G.** The Climates of the Continents. Demy 8vo. Pp. xvi+387. (Oxford: Clarendon Press, 1922.) 21s. net.\*

**Meteorological Office.** British Meteorological and Magnetical Year-Book, 1918. Part 4: Hourly Figures for Autograph Records, 1918. (London: H.M. Stationery Office, 1922.) 17s. net.

**Peppler, Dr. W.** Die Beobachtungen der Marine-drachenstationen Bredene/Meer und St. Michel bei Brügge in den Jahren 1915-1918. C. See- und Landbrise an der flandrischen Küste. D. Beobachtungen über die Turbulenz der Windes, besonders in der freien Atmosphäre. E. Die Temperaturverhältnisse mit einem Anhang: Feuchtigkeit und Wolkenhöhen. (Aerologische und Hydrographische Beobachtungen der Deutschen Marine-Stationen während der Kriegszeit 1914-1918, Heft 4.) Med. 4to. Pp. 60. (Hamburg: Deutsche Seewarte, 1922.) 4s.\*

**Schroute, Dr. C.** Ein Registrier-theodolit für Pilotballone: A Recording Theodolite for Pilot-balloons. (Koninklijk Nederlandsch Meteorologisch Instituut. No. 102. Mededeelingen en Verhandelingen, 26.) Roy. 8vo. Pp. 41. (Utrecht: Kemink en Zoon, 1921.) 0.80 F.\*

### Mineralogy

**Andree, Dr. J.** Bergbau in der Vorzeit. I: Bergbau auf Feuerstein, Kupfer, Zinn und Salz in Europa. Mit einem Anhang: Bergmännische Gewinnung von Kalkspat, Ocker und Bergkristall. Pp. iv+72. (Leipzig: C. Kabitzsch, 1922.) 50 marks.

**Imperial Mineral Resources Bureau.** Iron Ore. Part II: British Africa. (London: H.M. Stationery Office, 1922.) 3s. net.

**Jones, Dr. O. T.** Lead and Zinc. The Mining District of North Cardiganshire and West Montgomeryshire. (Memoirs of the Geological Survey. Special Reports on the Mineral Resources of Great Britain, Vol. 20.) Med. 8vo. Pp. vi+207. (London: H.M. Stationery Office, 1922.) 7s. net.\*

**Merrill, G. P.,** assisted by **Moodey, Margaret W., and Wherry, E. T.** Handbook and Descriptive Catalogue of the Collections of Gems and Precious Stones in the United States National Museum. (Smithsonian Institution: U.S. National Museum, Bulletin 118.) Roy. 8vo. Pp. viii+225. (Washington: Government Printing Office, 1922.) 50 cents.\*

### Geology

**Hecker, Prof. Dr. O.,** Herausgegeben von. Veröffentlichungen der Hauptstation für Erdbenenforschung in Jena (früher in Strassburg i. E.). Heft 1: Die Verbreitung der Erdbenen auf Grund neuerer makro- und mikroseismischer Beobachtungen und ihre Bedeutung für Fragen der Tektonik. Von Dr. A. Sieberg. 50 marks. Heft 2: Die Explosionskatastrophe von Oppau am 21. September 1921 nach den Aufzeichnungen der Erdbenenwarten. Von Prof. Dr. O. Hecker. 12 marks. (Jena: G. Fischer, 1922.)

### Geography: Travel

**A Manual of Belgium and the Adjoining Territories.** Demy 8vo. Pp. 595. (London: H.M. Stationery Office, 1922.) 11s. 6d.

**Baedeker, K.** The Dominion of Canada: Handbook for Travellers. Fourth revised and augmented edition. Fcap. 8vo. Pp. 500. (London: T. Fisher Unwin, Ltd., 1922.) 16s. net.

**Barnard, H. C.** India in Pictures. (Pictorial Geography Series.) Cr. 4to. Pp. 64. (London: A. and C. Black, Ltd., 1922.) 3s. 6d. net.

**Bartholomew's World Survey Series.** 8vo. South Eastern Australia. Mounted on cloth, 5s. net; sewed, 2s. 6d. net. Italy. Mounted on cloth, 3s. net; sewed, 1s. 6d. net. Spain and Portugal. Mounted on cloth, 3s. net; sewed, 1s. 6d. net. (Edinburgh: J. Bartholomew and Son, Ltd., 1922.)

**Bartholomew's Physical Wall Map of South Africa.** Large 1:1,400,000, or 22 miles to 1 inch. Printed in two large sheets, size when joined, about 4 feet by 6 feet. (Edinburgh: J. Bartholomew and Son, Ltd., 1922.) Sheets unmounted, 10s. 6d. net; dissected, mounted on cloth, folded to size 11 by 9 inches, and eyeleted for hanging on wall, 11s. net; joined, mounted on cloth, rollers and varnished, 11. 10s. net.

- Brunhes, Prof. J.** Human Geography: An Attempt at a Positive Classification; Principles and Examples. Translated by Prof. T. C. Le Comte. Edited by I. Bowman and Prof. R. E. Dodge. Pott 4to. Pp. xvi+648. (Chicago and New York: Rand McNally and Co.; London: G. G. Harrap and Co., Ltd., 1922.) 25s. net.
- Caddy, W. and C.** Switzerland in Summer; Discursive Information for Visitors. Part I: The Bernese Oberland. Cr. 8vo. Pp. 124. (London: Mills and Boon, Ltd., 1922.) 5s. net.
- Chisholm, G. G.** Handbook of Commercial Geography. New edition. Demy 8vo. Pp. xvi+824. (London: Longmans, Green and Co., 1922.) 25s. net.\*
- Close, Col. Sir C.** Note on Two Double, or Two-point, Map Projections. (Ordnance Survey; Professional Papers, New Series, No. 5.) Roy. 4to. Pp. 8+5 plates. (London: H.M. Stationery Office, 1922.) 1s. 6d. net.\*
- Conseil Permanent International pour l'Exploration de la Mer.** Bulletin Hydrographique. Variations de la Température de l'Eau de Surface de la Mer du Nord pendant les Années 1905-1914. Roy. 4to. Pp. v+41+4 plates. (Copenhagen: A. F. Host et Fils, 1922.)\*
- Cook's Guide to Paris.** New and revised edition. Cr. 8vo. Pp. 185. (London: T. Cook and Son; Simpkin, Marshall and Co., Ltd., 1922.) 2s. 6d. net.
- Coolidge, W. A. B.** The Bernese Oberland. (Conway and Coolidge's Climbers' Guides.) Vol. 1, Part 2. New edition. 18mo. Pp. 214. (London: T. Fisher Unwin, Ltd., 1922.) 5s. net.
- Fleure, Prof. H. J.** The Peoples of Europe. Cr. 8vo. Pp. 110. (London: Oxford University Press, 1922.) 2s. 6d. net.\*
- Garstin, C.** The Coasts of Romance. Cr. 8vo. Pp. 258. (London: W. Heinemann, 1922.) 7s. 6d. net.
- Geddie, J.** Described by Edinburgh. Painted by E. W. Haslehurst. Fcap. 4to. Pp. 68+12 plates. (London and Glasgow: Blackie and Son, Ltd., 1922.) 3s. net.
- Hall, J. N., and Nordhoff, C. B.** Faery Lands of the South Seas. 8vo. Pp. 355. (London: Harper and Bros., 1922.) 16s. net.
- Heaton, E. W.** South America. (A Regional Geography of the Six Continents. Book 6.) Cr. 8vo. Pp. v+85. (London: H. Russell, 1922.) 1s. 4d. net.
- Howarth, O. J. R.** The World About Us: A Study in Geographical Environment. Cr. 8vo. Pp. 94. (London: Oxford University Press, 1922.) 2s. 6d. net.\*
- Langenbeck, Prof. Dr. R.** Physische Erdkunde. 1: Die Erde als Ganzes und die Erdoberfläche. (Sammlung Goschen 849.) Pott 8vo. Pp. 110. (Berlin and Leipzig: W. de Gruyter and Co., 1922.) 1s. 6d.\*
- Mackintosh, C. W.** The New Zambesi Trail: A Record of Two Journeys to North-western Rhodesia, 1903 and 1920. 8vo. Pp. 370. (London: Marshall Bros., Ltd., 1922.) 10s. 6d. net.
- Newbigin, Dr. M. I.** Frequented Ways: A General Survey of the Land Forms, Climates, and Vegetation of Western Europe, considered in their Relation to the Life of Man; including a Detailed Study of Some Typical Regions. Demy 8vo. Pp. xi+321. (London: Constable and Co., Ltd., 1922.) 15s. net.\*
- Nightingale, Agnes.** Children of the World. (Visual Geography: A Practical Pictorial Method of Teaching Introductory Geography.) Fcap. 4to. Pp. 48. (London: A. and C. Black, Ltd., 1922.) 1s.
- Piggott, Dr. H., and Finch, R. J.** Great Britain and Ireland. (Dent's Historical and Economic Geographies.) Cr. 8vo. Pp. xi+351. (London: J. M. Dent and Sons, Ltd., 1922.) 4s. 6d.
- Price, E. S.** A Graded Course of Geography. Book 2: Second Year. Roy. 8vo. Pp. 64. (London: G. Philip and Son, Ltd., 1922.) 2s. net.
- Radford, A.** Industrial and Commercial Geography: with Special Reference to the British Empire. Cr. 8vo. Pp. 296. (London: W. Collins, Sons and Co., Ltd., 1922.) 3s. 6d. net.
- Rouch, J.** Le Pôle Sud: Histoire des voyages antarctiques. Gl. 8vo. Pp. 249. (Paris: E. Flammarion, 1921.) 7 francs net.\*
- Rutter, F.** Guide to Cambridge. Cr. 8vo. Pp. 80. (Cambridge: W. Heffer and Sons, Ltd., 1922.) 1s. net.
- Smith, Sir Ross.** 14,000 Miles through the Air. Ex. Cr. 8vo. Pp. xii+136. (London: Macmillan and Co., Ltd., 1922.) 10s. 6d. net.\*
- Turner, S.** The Conquest of the New Zealand Alps. Demy 8vo. Pp. 291. (London: T. Fisher Unwin, Ltd., 1922.) 21s. net.\*
- Warren, Lady.** Through Algeria and Tunisia on a Motor-bicycle. 8vo. Pp. 160. (London: J. Cape, 1922.) 10s. 6d. net.
- Wood, Prof. G. A.** The Discovery of Australia. Demy 8vo. Pp. xvi+541. (London: Macmillan and Co., Ltd., 1922.) 25s. net.\*

## Palæontology

- Deecke, Prof. Dr. W.** Phytalpaläontologie und Geologie. Roy. 8vo. Pp. iii+97. (Berlin: Gebrüder Borntraeger, 1922.) 6s. 3d.\*
- Hayasaka, I.** Paleozoic Brachiopoda from Japan, Korea and China. Part I: Middle and Southern China; Part 2: Upper Carboniferous Brachiopoda from the Honkei-ko Coal Mines, Manchuria. (Science Reports of the Tōhoku Imperial University, Sendai, Japan. Second series (Geology), Vol. 6, No. 1.) Imp. 4to. Pp. 137+6 plates. (Tokyo: Maruzen Co., Ltd., 1922.)\*
- Jordan, D. S.** The Fish Fauna of the California Tertiary. (Biological Sciences, Vol. 1, No. 4.) Sup. Roy. 8vo. Pp. 233-300+57 plates. (California: Stanford University, 1921.) 1 dollar.\*
- Newton, R. B.** Eocene Mollusca from Nigeria. With an Appendix on the Foraminifera from the same Deposits, by E. Heron-Allen and A. Earland. (Geological Survey of Nigeria, Bulletin No. 3.) 4to. Pp. 148+12 plates. (London: Crown Agents for the Colonies, 4 Millbank, 1922.) 17s. 6d. net.\*

## General Biology: Natural History

- Bouvier, Prof. E. L.** The Psychic Life of Insects. Translated by Dr. L. O. Howard. Cr. 8vo. Pp. xvii+377. (London: T. Fisher Unwin, Ltd., 1922.) 8s. 6d. net.\*
- Bullen, F. T.** Stories of Deep Sea Fish. Cr. 8vo. Pp. 194. (London: Religious Tract Society, 1922.) 5s. net.
- Bullen, F. T.** Stories of Whales and other Sea Creatures. Cr. 8vo. Pp. 148. (London: Religious Tract Society, 1922.) 3s. net.
- Castle, W. E.** Genetic Studies of Rabbits and Rats. (Publication No. 320.) Sup. Roy. 8vo. Pp. 55. (Washington: Carnegie Institution, 1922.) 1 dollar.\*
- Cross, M. I., and Cole, M. J.** Modern Microscopy: A Handbook for Beginners and Students. Fifth edition, revised and rearranged by H. F. Angus. With chapters on special subjects by various writers. Demy 8vo. Pp. x+315. (London: Baillière, Tindall and Cox, 1922.) 10s. 6d. net.\*
- Fabre, J. H.** Social Life in the Insect World. Translated by B. Miall. 8vo. Pp. 335. (London: T. Fisher Unwin, Ltd., 1922.) 8s. 6d. net.
- Garstang, Prof. W.** Songs of the Birds. Cr. 8vo. Pp. 101. (London: John Lane The Bodley Head Ltd., 1922.) 6s. net.\*
- Hornaday, W. T.** The Minds and Manners of Wild Animals: A Book of Personal Observations. Demy 8vo. Pp. x+328. (New York and London: C. Scribner's Sons, 1922.) 12s. 6d. net.
- Kerr, R.** Nature's Curiosity Shop; or, Recreations in Nature Study. 8vo. Pp. 190. (London: Religious Tract Society, 1922.) 6s. net.
- London County Council.** The Horniman Museum and Library, Forest Hill, S.E. A Handbook to the Collections illustrating a Survey of the Animal Kingdom. Second edition. Gl. 8vo. Pp. 66. (London: P. S. King and Son, Ltd., 1922.) 6d.\*
- Much, Prof. Dr. H.,** Herausgegeben von. Moderne Biologie. IV und V Vortrag: Zur Biologie der Lipode. Mit besonderer Berücksichtigung ihrer Antigenwirkung. Von Dr. H. Schmidt. Pp. 91. (Leipzig: C. Kabitzsch, 1922.) 3 francs.

- Seers, H. W.** More Nature Stories. (The Story-Teller's Series.) Cr. 8vo. Pp. 256. (London: G. G. Harrap and Co., Ltd., 1922.) 4s. 6d. net.\*
- Shann, Prof. E. W.** First Lessons in Practical Biology. Cr. 8vo. Pp. xv+256. (London: G. Bell and Sons, Ltd., 1922.) 5s.\*
- Westell, W. P.** Nature Photography and Some British Mammals and Birds. (From "Every Boy's Book of British Natural History.") Cr. 8vo. Pp. 174. (London: Religious Tract Society, 1922.) 3s. net.
- Westell, W. P.** British Natural History Studies: Reptiles, Amphibians, Fishes, etc. Cr. 8vo. Pp. 118. (London: Religious Tract Society, 1922.) 3s. net.
- Westell, W. P.** British Natural History. Cr. 8vo. Pp. 174. (London: Religious Tract Society, 1922.) 3s. net.

### Botany: Horticulture: Forestry

- Babington, C. C.** Manual of British Botany: containing the Flowering Plants and Ferns arranged according to the Natural Orders. Tenth edition, with amended Nomenclature and an Appendix, edited by A. J. Wilmott. Gl. 8vo. Pp. lvi+612. (London: Gurney and Jackson, 1922.) 16s. net.\*
- Gardiner, V. R., Bradford, F. C., and Hooker, junr., H. D.** The Fundamentals of Fruit Production. Pp. xvi+686. (New York and London: McGraw-Hill Book Co., Inc., 1922.) 22s. 6d. net.
- Hiley, W. E., and Cunliffe, N.** An Investigation into the Relation between Height Growth of Trees and Meteorological Conditions. Imp. 8vo. Pp. 19+3 plates. (Oxford: Clarendon Press, 1922.) 3s. 6d. net.\*
- Karsten, Prof. Dr. G., and Schenck, Prof. Dr. H.,** Herausgegeben von. Vegetationsbilder. 14 Reihe, Heft 4: Die Halophyten im Marschgebiete der Jade. Von Dr. H. Nitzschke. (Jena: G. Fischer, 1922.) 60 marks.
- Kolkwitz, Prof. Dr. R.** Pflanzenforschung. I Heft: Phanerogamen (Blümpflanzen). (Jena: G. Fischer, 1922.) 30 marks.
- Maiden, J. H.** A Critical Revision of the Genus *Eucalyptus*. Roy. 4to. Vol. 6, Part 2. (Part 52 of the Complete Work.) Pp. iii+61-107+plates 212-215. Vol. 6, Part 3. (Part 53 of the Complete Work.) Pp. iv+108-165+plates 216-219. (Sydney: W. A. Gullick, 1922.) 3s. 6d. each.\*
- Salt, H. S.** The Call of the Wildflower. Cr. 8vo. Pp. 192. (London: G. Allen and Unwin, Ltd., 1922.) 6s. net.\*
- Schlich, Sir W.** Schlich's Manual of Forestry. Vol. 1: Forest Policy in the British Empire. Fourth edition, revised and enlarged. Demy 8vo. Pp. xi+342. (London: Bradbury, Agnew and Co., Ltd., 1922.) 15s. net.\*
- Smith, K. M., and Gardner, J. C. M.** Insect Pests of the Horticulturalist: Their Nature and Control. Vol. 1: Onion, Carrot, and Celery Flies. Cr. 4to. Pp. vi+76+plates. (London: Benn Bros. Ltd., 1922.) 7s. 6d. net.\*

- Stone, H., and Cox, H. A.** School of Forestry, University, Cambridge. A Guide to the Identification of the More Useful Timbers of Nigeria. Demy 8vo. Pp. 111. (London: Crown Agents for the Colonies, 4 Millbank, 1922.) 5s. net.\*
- Storey, F. W., and Wright, K. M.** South African Botany. Second edition. Cr. 8vo. Pp. viii+220. (London: Longmans, Green and Co., 1922.) 6s. 6d. net.
- Vanderlinden, Dr. E.** Observations phénologiques sur des végétaux. Sup. Roy. 8vo. Pp. 14+4 tables+15 plates. (Bruxelles: Imprimerie Médicale et Scientifique, 1922.)\*

### Zoology

- Alverdes, Dr. F.** Studien an Infusorien über Flimmerbewegung, Lokomotion und Reizbeantwortung. (Arbeiten aus dem Gebeir der experimentellen Biologie, Heft 3.) Sup. Roy. 8vo. Pp. iv+130. (Berlin: Gebrüder Borntraeger, 1922.) 12s.\*
- Blaissid, Prof. F. E.** New Species of Melyridae, Chrysomelidae and Tenebrionidae (Coleoptera) from the Pacific Coast, with Notes on other Species. (Biological Sciences, Vol. 1, No. 3.) Sup. Roy. 8vo. Pp. 133-231. (California: Stanford University, 1921.) 1 dollar.\*

- Chun, Prof. C.,** Herausgegeben von, und nach seinem Tode fortgesetzt von **A. Brauer, E. Vanhöffen, und C. Apstein.** Wissenschaftliche Ergebnisse der Deutschen Tiefsee-Expedition auf dem Dampfer "Valdivia" 1898-1899. XIX Band, Heft 6: Die Antipatharien (Nachtrag) der Deutschen Tiefsee-Expedition. Von Prof. Dr. F. Pax; und XXII Band, Heft 1: Gephyreen der Deutschen Tiefsee-Expedition. Von Prof. Dr. W. Fischer. (Jena: G. Fischer, 1922.) 50 marks.

- Ferris, Prof. G. F.** Contributions toward a Monograph on the Sucking Lice. Part 2. (Biological Sciences, Vol. 2, No. 2.) Sup. Roy. 8vo. Pp. 53-133. (California: Stanford University, 1921.) 1 dollar.\*

- Gilchrist, J. D. F., and Bonde, C. von.** Practical Zoology: for Medical and Junior Students. Roy. 8vo. Pp. 340. (Edinburgh: E. and S. Livingstone, 1922.) 15s. net.\*

- Lundbeck, W.** Diptera Danica: Genera and Species of Flies hitherto found in Denmark. Part 6: Pipunculidae, Phoridae. Roy. 8vo. Pp. 455. (Copenhagen: G. E. C. Gad; London: Wheldon and Wesley, Ltd., 1922.)\*

- Morrison, H., and Morrison, Emily.** A Redescription of the Type Species of the Genera of Coccidae based on Species originally described by Maskell. (No. 207. From the Proceedings of the U.S. National Museum, Vol. 60, Art. 12.) Med. 8vo. Pp. 120+6 plates. (Washington: Government Printing Office, 1922.)\*

### Agriculture

- Gehrs, J. H.** Live Stock and Farm Mechanics. Cr. 8vo. Pp. viii+393. (New York: The Macmillan Co.; London: Macmillan and Co., Ltd., 1922.) 6s. net.

- McCandlish, Prof. A. C.** The Feeding of Dairy Cattle. Ex. Cr. 8vo. Pp. xix+281. (New York: J. Wiley and Sons, Inc.; London: Chapman and Hall, Ltd., 1922.) 12s. 6d. net.\*

- Rew, Sir H.** The Story of the Agricultural Club, 1918-1921. Demy 8vo. (London: P. S. King and Son, Ltd., 1922.) 10s. 6d. net.

- Weaver, J. E., Jean, F. C., and Crist, J. W.** Development and Activities of Roots of Crop Plants: A Study in Crop Ecology. (Publication No. 316.) Sup. Roy. 8vo. Pp. vi+117+14 plates. (Washington: Carnegie Institution, 1922.) 2 dollars.\*

### Anatomy: Physiology

- Arthus, Prof. M.** Précis de Physiologie Microbienne. Pp. 408. (Paris: Masson et Cie, 1921.) 17 francs net.

- Bradley, O. C.** The Topographical Anatomy of the Thorax and Abdomen of the Horse. Roy. 8vo. Pp. 216. (Edinburgh: W. Green and Son, Ltd., 1922.) 21s. net.

- Gérard, G.** Manuel d'anatomie humaine. 2e édition revue et augmentée. 8vo. Pp. 1275+4 planches. (Paris: Masson et Cie, 1922.) 75 francs net.

- Landouzy, L., et Bernard, L.** Eléments d'Anatomie et de Physiologie Médicales. 2e édition entièrement refondue. Pp. 867+4 planches. (Paris: Masson et Cie, 1921.) 50 francs net.

- Lüdke, Prof. Dr. H., and Schlayer, Prof. Dr. C. R.** Lehrbuch der pathologischen Physiologie für Studierende und Ärzte. Unter Mitarbeit von H. Eppinger, F. Fischer, J. Forsbach, E. Forster, H. Hirschfeld, E. Leschke, L. Lichtwitz, O. Loewi, H. Lüdke, C. J. Rothberger, C. R. Schlayer, J. Strasburger, R. van den Velden. Pp. xii+819. (Leipzig: J. A. Barth, 1922.) 540 marks.

- McKillop, Margaret.** Food Values: What they are, and How to Calculate Them. Second edition (revised and enlarged). Cr. 8vo. Pp. viii+171. (London: G. Routledge and Sons, Ltd.; New York: E. P. Dutton and Co., 1922.) 3s. 6d. net.\*

- Plimmer, Violet G., and Plimmer, Prof. R. H. A.** Vitamins and the Choice of Food. Demy 8vo. Pp. xii+164. (London: Longmans, Green and Co., 1922.) 7s. 6d. net.\*

**Smith, H. M.** Gaseous Exchange and Physiological Requirements for Level and Grade Walking. (Publication No. 309.) Sup. Roy. 8vo. Pp. viii+310. (Washington: Carnegie Institution, 1922.) 6 dollars.\*

**Underwood, A. S.** Aids to Dental Anatomy and Physiology. (Students' Aids Series.) Fourth edition, revised by B. Underwood. Pott 8vo. Pp. 176. (London: Baillière, Tindall and Cox, 1922.) 3s. 6d. net.

**Vernon, Dr. H. M.**, assisted by **Bedford, T.** Two Investigations in Potters' Shops. (Medical Research Council. Reports of the Industrial Fatigue Research Board, No. 18.) (Potteries Series, No. 1.) Med. 8vo. Pp. 74. (London: H.M. Stationery Office, 1922.) 2s. 6d. net.\*

### Anthropology: Ethnography

**Bender, Prof. H. H.** The Home of the Indo-Europeans. Ex. Cr. 8vo. Pp. 58. (Princeton: University Press; London: Oxford University Press, 1922.) 4s. 6d. net.\*

**Corrêa, Prof. A. A. Mendes.** Homo (Os Modernos Estudos sobre a Origem do Homem). Post 8vo. Pp. 318. (Lisboa, Porto, Coimbra: Lumen Empresa Internacional Editora, 1921.)\*

**Giddings, Prof. F. H.** Studies in the Theory of Human Society. Demy 8vo. Pp. vii+308. (New York: The Macmillan Co.; London: Macmillan and Co., Ltd., 1922.) 14s. net.\*

**Giuffrida-Ruggeri, V.** The First Outlines of a Systematic Anthropology of Asia: with Tables of Stature, Cephalic Index, and Nasal Index of Living Subjects. (University of Calcutta Anthropological Papers.) Translated from the Italian by Haranchandra Chakladar. 8vo. Pp. 110. (London: Luzac and Co., Ltd., 1922.) 2s. 6d. net.

**Hartland, Dr. E. S.** The Frazer Lecture, 1922. The Evolution of Kinship: An African Study. Med. 8vo. Pp. 31. (Oxford: Clarendon Press, 1922.) 2s. net.\*

**Mahalanobis, P. C.** Anthropological Observations on the Anglo-Indians of Calcutta. Part I: Analysis of Male Stature. (Records of the Indian Museum, Vol. 23.) Sup. Roy. 8vo. Pp. 96+4 plates. (Calcutta: Zoological Survey of India, 1922.) 2 rupees.\*

**Narasu, P. Lakshmi.** A Study of Caste. Cr. 8vo. Pp. viii+160. (Madras: K. V. Raghavulu, 1922.) 1.8 rupees.\*

**Peake, H.** The English Village: The Origin and Decay of its Community. An Anthropological Interpretation. Demy 8vo. Pp. 251. (London: Benn Bros. Ltd., 1922.) 15s. net.\*

**Wissler, C.** The American Indian: An Introduction to the Anthropology of the New World. Second edition. Med. 8vo. Pp. xxi+474. (London: Oxford University Press, 1922.) 24s. net.

### Philosophy: Psychology

**A Student of Psychology.** Auto-suggestion: What it is and How to Practise it. Fcap. 8vo. Pp. 26. (London: Jarrolds Ltd., 1922.) 1s. net.

**Baines, A. E.** The Origin and Problem of Life: A Psycho-Physiological Study. Cr. 8vo. Pp. xii+97. (London: G. Routledge and Sons, Ltd., 1922.)

**Bonar, J.** Philosophy and Political Economy in Some of their Historical Relations. (Library of Philosophy.) 8vo. Pp. 441. (London: G. Allen and Unwin, Ltd., 1922.) 16s. net.

**Brill, Dr. A. A.** Fundamental Conceptions of Psycho-analysis. Demy 8vo. Pp. vii+344. (London: G. Allen and Unwin, Ltd., 1922.) 12s. 6d. net.\*

**Carr, Prof. H. W.** A Theory of Monads: Outlines of the Philosophy of the Principle of Relativity. Med. 8vo. Pp. viii+351. (London: Macmillan and Co., Ltd., 1922.) 15s. net.

**Dewey, J.** Human Nature and Conduct: An Introduction to Social Psychology. Ex. Cr. 8vo. Pp. vii+336. (London: G. Allen and Unwin, Ltd., 1922.) 10s. 6d. net.

**Driesch, Prof. Dr. H.** Geschichte des Vitalismus. Zweite verbesserte und erweiterte Auflage des ersten Hauptteiles des Werkes "Der Vitalismus als Geschichte und als Lehre." (Natur- und kulturphilosophische Bibliothek, Band III.) Pp. x+213. (Leipzig: J. A. Barth, 1922.) 90 marks.

**Eyre, Mary B.** Psychology and Mental Hygiene for Nurses. Cr. 8vo. Pp. xi+208. (New York: The Macmillan Co.; London: Macmillan and Co., Ltd., 1922.) 7s. net.

**Haldane, Viscount.** The Philosophy of Humanism and of other Subjects. Demy 8vo. Pp. xiv+302. (London: J. Murray, 1922.) 12s. net.\*

**Hall, G. S.** Senescence: The Last Half of Life. Med. 8vo. Pp. xxvii+518. (London: D. Appleton and Co., 1922.) 21s.

**Jackson, Dr. J. A.**, and **Salisbury, H. M.** Outwitting our Nerves: A Primer of Psychotherapy. Cr. 8vo. Pp. viii+403. (London: Kegan Paul and Co., Ltd., 1922.) 7s. 6d. net.\*

**Lange, C. G.**, and **James, W.** The Emotions. (Psychology Classics, Vol. 1.) Med. 8vo. Pp. 135. (Baltimore, Md.: Williams and Wilkins Co., 1922.) 4 dollars.\*

**Lindworsky, Dr. J.** Umrisskizze zu einer theoretischen Psychologie. (Sonderabdruck aus Zeitschrift für Psychologie, Band 89, Heft 1-3.) Pp. 47. (Leipzig: J. A. Barth, 1922.) 30 marks.

**Lipmann, O.**, and **Stern, W.** Herausgegeben von. Schriften zur Psychologie der Berufseignung und des Wirtschaftslebens. Heft 20: Bibliographie zur psychologischen Berufsberatung, Berufseignungsforschung und Berufkunde. Unter Mitwirkung von F. Baumgarten zusammengestellt von O. Lipmann. Pp. 60. 40 marks. Heft 21: Die Münchener Eignungsprüfung für Buchdrucker und Schriftsetzer. Von A. Huth. Pp. 28. 15 marks. Heft 22: Die Fakultätsdifferenzen als psychologische Gruppenunterschiede bei den Universitätsstudenten. Von Annie Wisse. Pp. 85. 36 marks. (Leipzig: J. A. Barth, 1922.)

**Lotze, H.** Grundzüge der Logik und Enzyklopaedie der Philosophie. Large 8vo. Pp. 128. (Leipzig: S. Hirzel, 1922.) 6s.

**McCall, Prof. W. A.** How to Measure in Education. Ex. Cr. 8vo. Pp. xiii+416. (New York: The Macmillan Co.; London: Macmillan and Co., Ltd., 1922.) 15s. net.\*

**Nys, Prof. D.** La Notion d'Espace. (Fondation Universitaire de Belgique.) Med. 8vo. Pp. 446. (Bruxelles: Robert Sand; London: Oxford University Press, 1922.) 15s. net.\*

**Peucesco, Dr. M. Gr.** Le Mécanisme du Courant de la Conscience. Roy. 8vo. Pp. 191. (Paris: F. Alcan, 1922.) 10 francs.\*

**Rivers, Dr. W. H. R.** Instinct and the Unconscious: A Contribution to a Biological Theory of the Psycho-neuroses. (Cambridge Medical Series.) Second edition. Demy 8vo. Pp. viii+278. (Cambridge: At the University Press, 1922.) 15s. net.

**Shann, G.** The Evolution of Knowledge. Cr. 8vo. Pp. vii+100. (London: Longmans, Green and Co., 1922.) 4s. 6d. net.\*

**Sinclair, May.** The New Idealism. Med. 8vo. Pp. xvi+333. (London: Macmillan and Co., Ltd., 1922.) 14s. net.

**Solly, J. R.** Freewill and Determinism: An Old Controversy and its Present Position. Cr. 8vo. Pp. 27. (London: Constable and Co., Ltd., 1922.) Paper, 2s. 6d. net; boards, 3s. 6d. net.

**Zeller, Dr. E.** Outlines of the History of Greek Philosophy. Translated with Author's sanction by Sarah F. Alleyne and Evelyn Abbott. New impression. Cr. 8vo. Pp. 378. (London: Longmans, Green and Co., Ltd., 1922.) 6s. net.

### Bacteriology

**Partridge, W.** Aids to Bacteriology. (Students' Aids Series.) Fourth edition. Pott 8vo. Pp. 284. (London: Baillière, Tindall and Cox, 1922.) 5s. net.

## Medicine: Surgery

- Bandelier, Dr. B., and Roepke, Prof. Dr. O.** Lehrbuch der spezifischen Diagnostik und Therapie der Tuberkulose: Für Aerzte und Studierende. 11-13 Auflagen. Pp. xiv+631. (Leipzig: C. Kabitzsch, 1922.) 20 francs.
- Bardswell, N. D.,** Edited by. The Tuberculosis Clinic. (Modern Clinic Manuals.) Ex. Cr. 8vo. Pp. v+111. (London: Bale, Sons, and Danielsson, Ltd., 1922.) 6s. net.
- Bianchi, Prof. L.** The Mechanism of the Brain and the Function of the Frontal Lobes. Authorised translation from the Italian by J. H. Macdonald. Roy. 8vo. Pp. 348. (Edinburgh: E. and S. Livingstone, 1922.) 21s. net.
- Black, N.** Local Anaesthesia: Its Theory and Practice in Dental Surgery. Second edition. Cr. 8vo. Pp. 79. (London: Bale, Sons, and Danielsson, Ltd., 1922.) 5s. net.
- Borntraeger, Dr. J.** Preussische Gebühren-Ordnung für Ärzte und Zahnärzte vom 15 März 1922, mit eingehenden Erläuterungen und den für das Erwerbleben der Medizinalpersonen gültigen Bestimmungen sowie mit dem Gesetz über die Gebühren der Medizinalbeamten. Sechste Auflage. Pp. vi+101. (Leipzig: C. Kabitzsch, 1922.) 3 francs.
- Breitensteins Repetitorien.** Nr. 65: Repetitorium der medizinischen Terminologie (Medizinisches Taschenwörterbuch). Von Dr. J. Mahler. 4. Auflage. Pp. iv+208. (Leipzig: J. A. Barth, 1922.) 60 marks.
- Caillé, A.** Postgraduate Medicine: Prevention and Treatment of Disease. Roy. 8vo. Pp. 1,023. (London: D. Appleton and Co., 1922.) 40s. net.
- Clement, A.** Everyman his own Minister of Health. Cr. 8vo. Pp. 94. (London: Quality Press Co., 1922.) 2s. 6d. net.\*
- Crookshank, F. G.** Influenza: Essays by Several Authors. Med. 8vo. Pp. xii+529. (London: W. Heinemann (Medical Books) Ltd., 1922.) 30s. net.\*
- Cummer, Prof. C. L.** A Manual of Clinical Laboratory Methods. Med. 8vo. Pp. 484. (London: H. Kimpton, 1922.) 28s. net.\*
- Delf, Dr. E. M.** Studies in Experimental Scurvy: with Special Reference to the Antiscorbutic Properties of some South African Foodstuffs. (Publication No. 14.) Sup. Roy. 8vo. Pp. 105. (Johannesburg: South African Institute for Medical Research, 1921.) 5s.\*
- Dick, J. L.** Rickets: A Study of Economic Conditions and their Effects on the Health of the Nation. (In two parts, combined in one volume.) 8vo. Pp. xiii+488. (London: W. Heinemann (Medical Books) Ltd., 1922.) 25s. net.
- Dornblüth.** Arzneimittel der heutigen Medizin mit therapeutischen Notizen zusammengestellt für prakt. Aerzte und Studierende der Medizin. 13. Auflage bearbeitet von Prof. Dr. C. Bachem. Pp. vii+507. (Leipzig: C. Kabitzsch, 1922.) 8 francs.
- Flatau, Dr. S.** Leitfaden der weiblichen Gesundheitspflege. 4. Auflage. Pp. viii+160. (Leipzig: C. Kabitzsch, 1922.) 2.50 francs.
- Gaifami, Dott. P.** Le Indicazioni Attuali alla Provocazione dell'Aborto. (Collezione Bardi di Attualità della Medicina.) Cr. 8vo. Pp. 156. (Roma: Libreria di Scienze e Lettere, 1922.)\*
- Goddard, H. H.** School Training of Defective Children. (School Efficiency Series.) 8vo. Pp. 97. (London: G. G. Harrap and Co., Ltd., 1922.) 7s. 6d. net.
- Gould, E. P.** Surgical Pathology. (Students' Synopsis Series.) Cr. 8vo. Pp. 175. (London: J. and A. Churchill, 1922.) 6s. net.
- Hare, H. A.** A Text Book of Practical Therapeutics. Eighteenth edition, enlarged. Roy. 8vo. Pp. 1038. (London: H. Kimpton, 1922.) 36s. net.
- Harrow, Dr. B.** Glands in Health and Disease. Cr. 8vo. Pp. xv+218. (New York: E. P. Dutton and Co., 1922.)\*
- Holt, L. E., and Howland, J.** The Diseases of Infancy and Childhood: For the Use of Students and Practitioners of Medicine. Eighth edition, fully revised. Med. 8vo. Pp. xix+1127. (London: D. Appleton and Co., 1922.) 35s. net.
- Howard, R.** The Practice of Surgery. Third edition. Roy. 8vo. Pp. 1287. (London: E. Arnold and Co., 1922.) 30s. net.
- Katz, Dr. L., and Blumenfeld, Prof. Dr. F.** Handbuch der speziellen Chirurgie des Ohres und der oberen Luftwege. 3. Auflage. 5 Teile in 4 Bänden. Band I, 1. Hälfte. Pp. vi+318+151 Tafeln. 40 francs. Band IV. Pp. iv+831+63 Tafeln. 50 francs. (Leipzig: C. Kabitzsch, 1922.)
- Kempster, C.** Dental Radiology. Cr. 8vo. Pp. 200. (London: The Scientific Press, Ltd., 1922.) 10s. 6d. net.
- Keynes, G.** Blood Transfusion. (Oxford Medical Publications.) Demy 8vo. Pp. 166. (London: H. Frowde and Hodder and Stoughton, 1922.) 8s. 6d. net.
- Kroenig, Prof. Dr. B., and Friedrich, Dr. W.** The Principles of Physics and Biology of Radiation Therapy. Sup. Roy. 8vo. Pp. 271+20 plates. (London: W. Heinemann (Medical Books) Ltd., 1922.) 42s. net.
- Labbe, M.** A Clinical Treatise on Diabetes Mellitus. 8vo. Pp. 382. (London: W. Heinemann (Medical Books) Ltd., 1922.) 18s. net.
- Levy, A. G.** Chloroform Anaesthesia. 8vo. Pp. 159. (London: J. Bale, Sons, and Danielsson, Ltd., 1922.) 7s. 6d. net.
- Liebreich, Dr. É.** Le Sang in vitro: Eosinophilie-Fibrinogenese Phagocytose des hématies. Pp. 128+2 planches. (Paris: Masson et Cie, 1922.) 10 francs net.
- Lister, Sir F. S., and Thompson, H. O. F.** Tropical Ulcer in Native Mine Labourers on the Witwatersrand. (Publication No. 13.) Sup. Roy. 8vo. Pp. 8. (Johannesburg: South African Institute for Medical Research, 1921.) 5s.\*
- Mavrogordato, A.** Studies in Experimental Silicosis and other Pneumonokonioses. (Publication No. 15.) Sup. Roy. 8vo. Pp. 58+29 plates. (Johannesburg: South African Institute for Medical Research, 1922.) 5s.\*
- Ministry of Health.** Reports on Public Health and Medical Subjects. No. 12: Enteric Fever Epidemic at Bolton-upon-Dearne. (London: H.M. Stationery Office, 1922.) 2s. net.
- Moore, R. F.** Medical Ophthalmology. 8vo. Pp. 329. (London: J. and A. Churchill, 1922.) 15s. net.
- Much, Prof. Dr. H.** Moderne Biologie. 2 und 3 Vortrag: Spezifische und unspezifische Reiztherapie. Pp. 66. (Leipzig: C. Kabitzsch, 1922.) 1.50 francs.
- Oppenheim, Prof. Dr. M., Rille, Prof. Dr. J. H., and Ullmann, Dr. K.,** Herausgegeben von. Die Schädigungen der Haut durch Beruf und gewerbliche Arbeit. Band I, Lieferung 2-8 (Schluss von Band I). Pp. viii+73-336+7 Tafeln. (Leipzig: L. Voss, 1922.) 400 marks.
- Orlowski, Dr. P.** Die Impotenz des Mannes. Für Aerzte dargestellt. 3. Auflage. Pp. vii+160+3 Tafeln. (Leipzig: C. Kabitzsch, 1922.) 5 francs.
- Fanse, Dr. R.** Der praktische Hals-, Nasen- und Ohrenarzt. Pp. 160. (Leipzig: C. Kabitzsch, 1922.) 6 francs.
- Parsons, Dr. H. F.** Isolation Hospitals. Second edition, revised and partly rewritten by Dr. R. Bruce Low. (Cambridge Public Health Series.) Demy 8vo. Pp. xiv+281. (Cambridge: At the University Press, 1922.) 25s. net.
- Polano, Prof. Dr. O.** Geburtshilflich-gynäkologische Präpödeutik. Eine theoretische und praktische Einführung in die Klinik und in die Untersuchungskurse. 3 und 4. Auflage. Pp. xiii+195. (Leipzig: C. Kabitzsch, 1922.) 5 francs.
- Pottenger, F. M.** Clinical Tuberculosis. 2 vols. Second edition. Roy. 8vo. Pp. 707; 725. (London: H. Kimpton, 1922.) 75s. net.
- Poulsson, Dr. E.** Lehrbuch der Pharmakologie. 6. Auflage. 4to. Pp. 580. (Leipzig: S. Hirzel, 1922.) 10s. 8d.
- Rabinowitsch, Prof. Dr. L.,** Herausgegeben von. Tuberkulose-Bibliothek. Nr. 8: Biologische Vorfragen der experimentellen Tuberkuloseforschung von dermatologischen Standpunkte aus. Von Prof. Dr. A. Jesionek. Pp. 44. (Leipzig: J. A. Barth, 1922.) 2 francs.

**Robertson, W. G. A.** The Students' Guide to Vaccination. (Black's Medical Series.) Cr. 8vo. Pp. viii+88. (London: A. and C. Black, Ltd., 1922.) 3s. 6d. net.

**Rubner, Gruber, Ficker.** Handbuch der Hygiene. Band V: Nahrungsmittel. Large 8vo. Pp. 320. (Leipzig: S. Hirzel, 1922.) 18s.

**Savill, T. D.** A System of Clinical Medicine: the Diagnosis, Prognosis, and Treatment of Disease for Students and Practitioners. Sixth edition. Roy. 8vo. Pp. 980. (London: E. Arnold and Co., 1922.) 28s. net.

**Schjerner, Prof. Dr. O. von,** Herausgegeben von. Handbuch der ärztlichen Erfahrungen im Weltkriege 1914-18. In 9 Bänden. Band 1/2: Chirurgie. Herausgegeben von Dr. E. Payr und Dr. C. Franz. Pp. xxxii+810+vi+3 Tafeln. 100 francs. Band V: Augenheilkunde. Herausgegeben von Prof. Dr. T. Axenfeld. Pp. viii+560+3 Tafeln. 60 francs. Band VII: Hygiene. Herausgegeben von Prof. Dr. W. Hoffmann. Pp. viii+618+3 Tafeln. 40 francs. Band IX: Röntgenologie. Herausgegeben von Prof. Dr. R. Grashey. Pp. vi+384. 25 francs. (Leipzig: J. A. Barth, 1922.)

**Scott, T. B.** Endocrine Therapeutics: Practical Suggestions. Cr. 8vo. Pp. 127. (London: H. K. Lewis and Co., Ltd., 1922.) 5s. net.

**Simpson, F. E.** Radium Therapy. 4to. Pp. 391. (London: H. Kimpton, 1922.) 36s. net.

**Sopp, Dr. A.** Die Gicht, ihre Ursachen, Wesen und Bekämpfung. Gemeinverständlich dargestellt. Pp. iv+50. (Leipzig: C. Kabitzsch, 1922.) 2 francs.

**Sudhoff, K.** Herausgegeben von. Klassiker der Medizin. Band 2: Des Meisters Arnald von Villanova Parabeln der Heilkunst. Aus dem Lateinischen übersetzt, erklärt und eingeleitet von Prof. Dr. P. Diepgen. Pp. 68. 60 marks. Band 27: Albrecht Haller. Von den empfindlichen und reizbaren Teilen des menschlichen Körpers. Deutsch herausgegeben und eingeleitet von K. Sudhoff. Pp. 58. 54 marks. (Leipzig: J. A. Barth, 1922.)

**Ten Post-Graduate Lectures** delivered before the Fellowship of Medicine at the House of the Royal Society of Medicine, 1919-1920. With a preface by the Right Hon. Sir Clifford Allbutt. Demy 8vo. Pp. xvi+216. (London: J. Bale, Sons, and Danielsson, Ltd., 1922.) 10s. 6d. net.

**Tropical Hygiene** for African Schools. Pott 8vo. Pp. 64. (London: S.P.C.K., 1922.) 8d. net.

**Turner, A. L., and Porter, W. G.** The Skiagraphy of the Accessory Nasal Sinuses. Folio. (Edinburgh: W. Green and Son, Ltd., 1922.) 16s. net.

**Voltz, Prof. F.** Dosage Tables and Deep-Theory. Edited by R. Morton. Cr. 8vo. Pp. xii+98. (London: W. Heinemann (Medical Books) Ltd., 1922.) 10s. 6d. net.

**Wallich, Prof. V.** Éléments d'Obstétrique. Quatrième édition refondue. Pp. 709. (Paris: Masson et Cie, 1922.) 26 francs net.

**Webster, A.** Cardiac Arrhythmia and the Neocardiology. Folio. Pp. vii+195. (London: Watts and Co., 1922.) 21s. net.

**Williams, Dr. E. H.** Opiate Addiction: Its Handling and Treatment. Cr. 8vo. Pp. xxv+194. (New York: The Macmillan Co.; London: Macmillan and Co., Ltd., 1922.) 8s. net.

### Miscellaneous

**Aristotle,** The Works of. Translated into English. De Caelo, by J. L. Stocks: De Generatione et Corruptione, by Harold H. Joachim. Demy 8vo. (Oxford: Clarendon Press, 1922.) 10s. net.\*

**British Scientific Instrument Research Association.** Durability of Optical Glasses: Report of an Investigation on the Determination of the Durability of Optical Glasses, carried out by T. Haigh. Med. 8vo. Pp. 51+10 plates. (London: British Scientific Instrument Research Association, 26 Russell Square, 1921.) 7s. 6d.\*

**Department of the Interior:** Bureau of Education. Bulletin, 1921, No. 48: Educational Directory 1921-22. Med. 8vo. Pp. iii+142. (Washington: Government Printing Office, 1922.) 10 cents.\*

**Eikenberry, Prof. W. L.** The Teaching of General Science. (University of Chicago Nature-Study Series.) Cr. 8vo. Pp. xiii+169. (Chicago: University of Chicago Press; London: Cambridge University Press, 1922.) 2 dollars.\*

**Epps, W. Anderson Stuart, M.D.,** Physiologist, Teacher, Builder, Organizer, Citizen. Demy 8vo. Pp. xv+177. (Sydney: Angus and Robertson, Ltd., 1922.)\*

**Fleming, A. P. M., and Brocklehurst, H. J.:** An Introduction to the Principles of Industrial Administration. Ex. Cr. 8vo. Pp. vii+140. (London: Sir I. Pitman and Sons, Ltd., 1922.) 3s. 6d. net.\*

**Foster, Sir G.** The University of London (History, Present Resources, and Future Possibilities). Fcap. 4to. Pp. 48. (London: University of London Press, Ltd., 1922.) 1s. 6d. net.\*

**Garnett, Dr. W.** A Little Book on Water Supply. Med. 8vo. Pp. xv+144. (Cambridge: At the University Press, 1922.) 6s. 6d. net.\*

**Goddard, H. H.** Juvenile Delinquency. Cr. 8vo. Pp. vi+120. (London: Kegan Paul and Co., Ltd., 1922.) 3s. 6d. net.\*

**Howarth, O. J. R.** The British Association for the Advancement of Science: A Retrospect, 1831-1921. Med. 8vo. Pp. vii+318. (London: British Association, Burlington House, 1922.) 7s. 6d.\*

**Keltie, Sir J. S., and Epstein, Dr. M.,** Edited by. The Statesman's Year-Book: Statistical and Historical Annual of the States of the World for the Year 1922. Fifty-ninth Annual Publication, revised after Official Returns. Gl. 8vo. Pp. xlvii+1568. (London: Macmillan and Co., Ltd., 1922.) 20s. net.\*

**Lescarboura, A. C.** The Cinema Handbook. Pott 8vo. Pp. 507. (London: Sampson Low and Co., Ltd., 1922.) 14s. net.

**Luke, F., and Saunders, R. J.** Experimental Science in School. Gl. 8vo. Book I. Pp. viii+215, Book II. Pp. viii+216. (London: Sidgwick and Jackson, Ltd., 1922.) 2s. 6d. net each.

**Overton, G. L.** Clocks and Watches. (Pitman's Common Commodities and Industries.) Gl. 8vo. Pp. ix+127. (London: Sir I. Pitman and Sons, Ltd., 1922.) 3s. net.\*

**Paul, E., and C.,** Translated from the Russian by. The Restoration of Agriculture in the Famine Area of Russia. Demy 8vo. Pp. 167. (London: Labour Publishing Co., 1922.) 5s.

**Picard, E.** Discours et Mélanges. Demy 8vo. Pp. v+292. (Paris: Gauthier-Villars, 1922.) 10 francs.\*

**Prout, Dr. H. G.** A Life of George Westinghouse. (For a Committee of the American Society of Mechanical Engineers.) Med. 8vo. Pp. xiii+375. (London: Benn Bros. Ltd., 1922.) 18s. net.\*

**Rueff, J.** Des Sciences physiques aux Sciences morales: Introduction a l'Étude de la Morale et de l'Économie Politique Rationnelles. (Les Questions du Temps présent.) Cr. 8vo. Pp. xx+202. (Paris: F. Alcan, 1922.) 8 francs.\*

**Savage, Dr. W. G.** The Methods used for the Inspection of Canned Goods. Part 2: Canned Marine Products. (Department of Scientific and Industrial Research: Food Investigation Board. Special Report No. 10.) Roy. 8vo. Pp. iv+32. (London: H. M. Stationery Office, 1922.) 1s. 6d. net.\*

**Sydenham, Dr. Thomas,** Selected Works of. With a Short Biography and Explanatory Notes by J. D. Comrie. Cr. 8vo. Pp. viii+153. (London: Bale, Sons, and Danielsson, Ltd., 1922.) 8s. 6d. net.

**Sykes, Maj.-Gen. Sir F. H.** Aviation in Peace and War. 8vo. Pp. 140. (London: E. Arnold and Co., 1922.) 8s. 6d. net.

**"The Gas World"** Analyses of Municipal Gas Accounts, 1920-21. 4to. 2 Sheets, 20 in. x 21 in., folded in case. (London: Benn Bros., Ltd., 1922.) 21s. net.\*

**Thomson, Prof. J. A.,** Edited by. The Outline of Science: A Plain Story Simply Told. Vol. 1. 4to. Pp. iv+400. (London: G. Newnes, Ltd., 1922.) 31s. 6d. net.\*

**Trevelyan, G. M.** British History in the Nineteenth Century (1782-1901). Demy 8vo. Pp. xvi+445. (London: Longmans, Green and Co., 1922.) 12s. 6d. net.\*

**Wilson, Marjorie.** Klipper-Klopper and other Verses for Children. Cr. 8vo. Pp. 60. (London: G. G. Harrap and Co., Ltd., 1922.) 2s. 6d. net.\*



## Recent Scientific and Technical Books

*Volumes marked with an asterisk have been received at "NATURE" Office.*

## Mathematics

**Forsyth, Prof. A. R.** The Concomitants (including Differential Invariants) of Quadratic Differential Forms in Four Variables. (Proceedings of the Royal Society of Edinburgh, Session 1921-1922, Vol. 42, Part 2, No. 12.) Sup. Roy. 8vo. Pp. 147-212. (Edinburgh: R. Grant and Son; London: Williams and Norgate, 1922.) 7s. 4d.\*

**Gunther, R. T.** Early Science in Oxford. Part 2: Mathematics. Demy 8vo. Pp. 101. (London: Oxford University Press, 1922.) 10s. 6d. net.\*

**Juvert, Prof. G.** Introduction au Calcul tensoriel et au Calcul différentiel absolu. Roy. 8vo. Pp. iv+101. (Paris: A. Blanchard, 1922.) 12 francs.\*

**Pearson, Karl**, Edited by. Tables of the Incomplete  $\Gamma$ -Function. Computed by the Staff of the Department of Applied Statistics, University of London, University College. (Published for the Department of Scientific and Industrial Research.) 4to. Pp. xxxii+164. (London: H.M. Stationery Office, 1922.) 2l. 2s. net.\*

**Pryde, J.** Chambers's Seven Figure Logarithms of Numbers up to 100,000. Cr. 8vo. Pp. 200. (London and Edinburgh: W. and R. Chambers, Ltd., 1922.) 2s. 6d.

**Salmon-Fiedler.** Analytische Geometrie des Raumes. I Teil: Elemente und Theorie der Flächen. 2 Ordnung 5 Auflage, neubearbeitet von K. Kommerell. 1 Lieferung. (Leipzig: B. G. Teubner, 1922.) 16s.

**Simon, P.** La Recherche des lieux géométriques en géométrie analytique, à l'usage des élèves des classes de Mathématiques spéciales et des Étudiants des Instituts scientifiques des Facultés des Sciences. Pp. viii+232. (Paris: A. Colin, 1922.)

## Mechanics: Mechanical Engineering

**Aeronautical Research Committee.** Reports and Memoranda. No. 246: Experiments on Model Airships. 6s. 6d. net. No. 661: Consideration of Aircrew Theory in the Light of Data derived from an Experimental Investigation of the Distribution of Pressure over the Entire Surface of an Aircrew Blade, and also over Aerofoils of Appropriate Shapes. 3s. net. No. 689: Canonical Forms of the Equations of Motion of an Aeroplane in Still and Gusty Air. 9d. No. 752: Some Applications of the Vortex Theory of Aerofoils. 9d. No. 767: Calculation of the Characteristics of Tapered Wings. 3d. No. 776: Load Factors for Commercial Heavier-than-air Craft. 3d. net. (London: H.M. Stationery Office, 1922.)

**Allcutt, Prof. E. A., and King, G. J.** Engineering Inspection. Roy. 8vo. Pp. xv+187. (London: G. Routledge and Sons, Ltd., 1922.) 15s. net.\*

**Challéat, Général J., and Thomas, A.** Mécanique des affûts. (Encyclopédie scientifique.) 2<sup>e</sup> édition. Tome I. Gl. 8vo. Pp. 356. (Paris: G. Doin, 1922.)

**Granzer, Prof. R.** Schnellaufende Verbrennungsmaschinen, ihr Wesen und Verhalten. 4to. Pp. xii+398. (Berlin: R. C. Schmidt and Co., 1922.) 150 marks.

**Heap, F.** Petrol Cars and Lorries: Describing clearly and concisely the Construction and Operation of Modern Petrol Vehicles for carrying Passengers, Merchandise, etc. (Pitman's Technical Primers.) Pott 8vo. Pp. xii+111. (London: Sir I. Pitman and Sons, Ltd., 1922.) 2s. 6d. net.

**Hirschauer, Capt. L., and Dollfus, Ch.** L'Année aéronautique. 3<sup>e</sup> année (1921-1922). Imp. 8vo. Pp. viii+128. (Paris: Libr. Dunod, 1922.) 12 francs.

**Leask, A. R.** Marine Engines. Demy 8vo. Pp. xvi+424. (London: Simpkin, Marshall and Co., Ltd., 1922.) 21s. net.

**Moore, Capt. S. B.** Gears and Gearing. Roy. 8vo. Pp. 152. (London: P. Lund, Humphries and Co., 1922.) 12s. 6d. net.

**Ocagne, M. d'.** Vue d'ensemble sur les machines à calculer. Ex. Cr. 8vo. Pp. 69. (Paris: Gauthier-Villars et Cie, 1922.)

**Roesler, E.** Föbränningsmaskiner. Med särskild hänsyn till användningen av flytande bränsle. 8vo. Pp. viii+254. (Stockholm: H. Lindstahl, 1922.) 15 kr.

**Thompson, G., and Leslie, G. H.** Mechanics. Part I. Cr. 8vo. Pp. 160. (London: Cassell and Co., Ltd., 1922.) 2s. net.

**Wegmann, E.** The Design and Construction of Dams: Including Masonry, Earth, Rock-fill, Timber, and Steel Structures, also the Principal Types of Movable Dams. Seventh edition, revised and enlarged. Med. 4to. Pp. xvii+555+plates A-Z+plates AA-VV+plates I-III. (New York: J. Wiley and Sons, Inc.; London: Chapman and Hall, Ltd., 1922.) 50s. net.\*

**Zimmer, G. F.** The Mechanical Handling and Storing of Material: Being a Treatise on the Automatic and Semi-automatic Handling and Storing of Commercial Products. Third edition, thoroughly revised. Imp. 8vo. Pp. xx+804. (London: C. Lockwood and Son, 1922.) 63s. net.

## Physics: Electrical Engineering

**Air Ministry: Meteorological Office.** The Wireless Weather Manual: Being a Guide to the Reception and Interpretation of Weather Reports and Forecasts distributed by Wireless Telegraphy in Great Britain. (M.O. 255.) Med. 8vo. Pp. 24. (London: H.M. Stationery Office, 1922.) 9d. net.\*

**Allen, Dr. H. S.; Houstoun, Dr. R. A.; Peddie, Prof. W.** The Magnetic Character of the Quantum; Note on Professor Whittaker's Quantum Mechanism in the Atom; The Importance of Professor Whittaker's Atomic Model and of other Atomic Models. (Proceedings of the Royal Society of Edinburgh, Session 1921-1922, Vol. 42, Part 2, Nos. 13, 14, 15.) Sup. Roy. 8vo. Pp. 213-224. (Edinburgh: R. Grant and Son; London: Williams and Norgate, 1922.) 1s. 4d.\*

**Berthoud, A.** La Constitution des atomes. (Collection Payot.) Pp. 158. (Paris: Payot et Cie, 1922.) 4 francs.

**Brown, the late W. G.** On the Faraday-Tube Theory of Electro-Magnetism. (Proceedings of the Royal Society of Edinburgh, Session 1921-1922, Vol. 42, Part 2, No. 16.) Sup. Roy. 8vo. Pp. 225-246. (Edinburgh: R. Grant and Son; London: Williams and Norgate, 1922.) 2s. 8d.\*

**Chwolson, Prof. O. D.** Die Lehre von der strahlenden Energie. (Lehrbuch der Physik. Band 2, Abt. 2.) 2 Auflage. Herausgegeben von Prof. G. Schmidt. Large 8vo. Pp. xv+895+3 Tafeln. (Braunschweig: F. Vieweg und Sohn, 1922.) 240 marks.

**Davidge, H. T., and Hutchinson, R. W.** Technical Electricity. Fourth edition. Demy 8vo. Pp. xii+514. (London: University Tutorial Press, Ltd., 1922.) 10s. 6d.\*

**Dubroca, M.** L'Erreur de M. Einstein l'inacceptable théorie, L'Éther et le principe de relativité. 8vo. Pp. 49. (Paris: Gauthier-Villars et Cie, 1922.) 4 francs.

**Exner, Prof. F.** Vorlesungen über die physikalischen Grundlagen der Naturwissenschaften. 2 Auflage. 4to. Pp. xx+734. (Leipzig und Wien: F. Deuticke, 1922.) 320 marks.

**Fajans, Prof. Dr. K.** Radioaktivität und die neueste Entwicklung der Lehre von den chemischen Elementen. 4 erweiterte und zum Teil umgearbeitete Auflage. (Sammlung Vieweg, Heft 45.) Pp. 137+14 Tabellen. (Braunschweig: F. Vieweg und Sohn, 1922.) 72 marks.

**Fischer, L.** Die Wärme ein Gas! Eine neue Theorie der Wärme und der übrigen feinen Stoffe. Pp. 61. (Leipzig: H. A. Ludwig Degener, 1922.)

**Graetz, Prof. Dr. L.** Die Atomtheorie in ihrer neuesten Entwicklung. 6 Vorträge. Vierte Auflage. Large 8vo. Pp. viii+100. (Stuttgart: J. Engelhorn, 1922.) 20 marks.

**Graffigny, H. de.** Les Électro-aimants et les bobines d'induction: leurs principes, pièces constitutives, construction et applications des appareils. Gl. 8vo. Pp. viii+199. (Paris: Libr. Desforges, 1922.)

**Grube, Prof. Dr. G.** Grundzüge der angewandten Elektrochemie. 8vo. Band I: Elektrochemie der Lösungen. Pp. xii+270. (Dresden und Leipzig: T. Steinkopff, 1922.) 70 marks.

**Haldane, Vicomte.** Le Règne de la relativité. Traduction française par H. de Varigny. Pp. xxvi+590. (Paris: Gauthier-Villars et Cie, 1922.)

**Heaviside, O.** Electromagnetic Theory. Reissue in 3 vols. Demy 8vo. Vol. I: pp. xxii+466. Vol. 2: pp. xvi+547. Vol. 3: pp. 519. (London: Benn Bros., Ltd., 1922.) 3 vols., 5l. 5s. net.\*

**Holweck, M. F.** Recherches expérimentales sur les rayons X de grande longueur d'onde. 8vo. Pp. 59. (Paris: Masson et Cie, 1922.)

**Kirchberger, P.** La Théorie de la relativité exposée sans mathématiques. Traduction française de M. Thiers. Pp. 218. (Paris: Payot et Cie, 1922.) 5 francs.

**Kornerup, T.** Musical Acoustics based on the Pure Third-System. Translated by Phyllis A. Petersen. Cr. 4to. Pp. 56. (Copenhagen and Leipzig: W. Hansen, 1922.) 2s. 6d.\*

**Kraus, Prof. C. A.** The Properties of Electrically Conducting Systems: Including Electrolytes and Metals. (American Chemical Society Monograph Series.) Med. 8vo. Pp. 415. (New York: Chemical Catalog Co., Inc., 1922.) 4.50 dollars.\*

**Marshall, Dr. J.** The Quantum Theory of the Secondary Spectrum of Hydrogen. (Proceedings of the Royal Society of Edinburgh, Session 1921-1922, Vol. 42, Part 2, No. 17.) Sup. Roy. 8vo. Pp. 247-256. (Edinburgh: R. Grant and Son; London: Williams and Norgate, 1922.) 1s. 4d.\*

**Martens, F.** Die Welt als Wirkung strahlender Energien. Heft 3: Die Wirkung als Masse und Kraft. Die Welt der Zellenliebe. Über Instinkt, Bewusstsein und Seele. Das Leben als Stoffwechsel und Rhythmus. Schlaf und Tod. Zahl, Zeit und einiges andere. (Spengler und Einstein.) Large 8vo. Pp. 64. (Elberfeld: Selbstverlag; Hofbauer'sche Buchhandlung in Komm., 1922.) 14.40 marks.

**Mauduit, Prof. A.** Machines électriques. (Théorie, essais et construction.) Troisième édition. Roy. 8vo. Pp. xxviii+1180. (Paris: Libr. Dunod, 1922.) 80 francs.

**Moszkowski, A.** Einstein. Einblicke in seine Gedankenwelt. Gemeinverständliche Betrachtungen über die Relativitätstheorie und ein neues Weltssystem. Entwickelt aus Gesprächen mit Einstein. 8vo. Pp. 240. (Berlin: F. Fontane und Co., 1922.) 30 marks.

**National Physical Laboratory, The.** Collected Researches. Vol. 16, 1921. Med. 4to. Pp. iv+359. (London: H.M. Stationery Office, 1921.) 20s. net.\*

**Pécheux, Dr. H.** Traité d'électricité industrielle. 8vo. Tome I: Étude des courants électriques continus. Pp. 834. 58 francs. Tome II: Étude des courants électriques alternatifs. Pp. 376. 25 francs. (Paris: Libr. Delagrave, 1922.)

**Pohl, H.** Der Betrieb elektrischer Licht- und Kraftanlagen. Ein Handbuch für Ingenieure, Elektromonteur, Installateure, Betriebsführer, Schalttafelwärter, Kesselwärter, Maschinisten, sowie die Besitzer elektrischer Anlagen. (Bibliothek der gesamten Technik, Band 100.) 5. Auflage. Small 8vo. Pp. viii+133. (Berlin: Dr. M. Jänecke, 1922.) 40 marks.

**Raman, Prof. C. V.** Molecular Diffraction of Light. Demy 8vo. Pp. x+103. (Calcutta: The University, 1922.)\*

**Schlick, M.** Raum und Zeit in der gegenwärtigen Physik. Zur Einführung in das Verständnis der Relativitäts- und Gravitationstheorie. 4 vermehrte und verbesserte Auflage. Pp. vi+108. (Berlin: J. Springer, 1922.) 48 marks.

**Siebel, K.** Die Elektrizität in Metallen. (Sammlung Vieweg 62.) Large 8vo. Pp. v+97. (Braunschweig: F. Vieweg und Sohn, 1922.) 12 marks.

**Silbermann, H.** Elektrische Behandlung von Gasen. 8vo. Pp. vii+348. (Leipzig: Dr. M. Jänecke, 1922.) 320 marks.

**Snodgrass, R. T., and Camp, V. F.** Radio Receiving for Beginners. Cr. 8vo. Pp. 99. (London: Macmillan and Co., Ltd., 1922.) 3s. 6d. net.\*

**Sommerfeld, Prof. Dr. A.** Atombau und Spektrallinien. 3. Auflage. Large 8vo. Pp. xi+764. (Braunschweig: F. Vieweg und Sohn, 1922.) 60 marks.

**Tillieux, J.** Leçons élémentaires de physique expérimentale selon les théories modernes. Fasc. I. Pp. viii+219. (Louvain: Libr. Ceuterick, 1922.)

**Verschoye, W. D.** The Evolution of Atoms and Isotopes. Med. 8vo. Pp. 40. (London: J. J. Keliher and Co., Ltd., Craven House, Kingsway, 1922.) 1s. 9d.\*

**Yorke, J. P.** Magnetism and Electricity. New edition, completely rewritten. Cr. 8vo. Pp. viii+248. (London: E. Arnold and Co., 1922.) 5s. net.\*

## Chemistry

**Barnett, E. de B., and Thorne, P. C. L.** Organic Analysis: Qualitative and Quantitative. (London: University of London Press, Ltd., 1922.) 7s. 6d.

**Basin, J.** Chimie (métalloïdes) à l'usage des élèves des classes de seconde C. et D. Pott 8vo. Pp. 218. (Paris: Libr. Vuibert, 1922.)

**Berman, St.** Składniki powietrza oraz ich zastosowanie. 8vo. Pp. viii+103. (Warschau: Nkł. księż. K. Treptego, 1922.) 260 mkp.

**Berthsen, A.** Trattato di chimica organica. 3 edizione. Puntata I. 8vo. Pp. 280. (Milano: F. Vallardi, 1922.) 50 lire.

**Brooks, B. T.** The Chemistry of the Non-benzenoid Hydrocarbons and their Simple Derivatives. 8vo. Pp. 612. (New York: Chemical Catalog Co., Inc., 1922.) 7 dollars.

**Bruni, G.** Chimica inorganica. Lezioni tenute nel R. Politecnico di Milano. 8vo. Pp. xii+276. (Milano: Libreria C. Tamburini, 1922.) 5 lire.

**Byers, H. G.** An Outline of Qualitative Analysis of Inorganic Substances, including the Rare Elements. Pp. xi+216. (New York: D. Van Nostrand Co., 1922.) 2 dollars.

**Chazel, Dr. A.** Lehrbuch der Chemie und chemischen Technologie für Handelsakademien. Teil 1. 3. Auflage. Large 8vo. Pp. iv+223. (Wien und Leipzig: C. Fromme, 1922.) 100 marks.

**Chrzyszcz, T.** Gorzelnictwo. Teorja i praktyka. Tom II, z 80 rycinami. 4to. Pp. xii+117. (Warschau: Gebethner und Wolff, 1921.) 2200 mkp.

**Cluss, Prof. Dr. A.** Brennerlei. 2. Auflage. Small 8vo. Pp. ix+160. (Leipzig: Dr. M. Jänecke, 1922.) 50 marks.

**Coindet, E.** Où en est la photographie? (Collection des Mises au point.) 8vo. Pp. 282. (Paris: Gauthier-Villars et Cie, 1922.) 13 francs.

**Delaucx, J.** Les Colloïdes. 2<sup>e</sup> édition. Small 8vo. Pp. x+306. (Paris: Gauthier-Villars et Cie, 1922.) 10 francs.

**Ehrenstein, Dr. R.** Der praktische Chemiker. (Sammlung belehrender Unterhaltungsschriften, Band 77.) 8vo. Pp. vii+76. (Berlin-Wilmersdorf: Herm. Paetel, 1921.) 10 marks.

**Ephraïm, Prof. Dr. F.** Anorganische Chemie: Ein Lehrbuch zum Weiterstudium und zum Handgebrauch. Large 8vo. Pp. viii+728. (Dresden und Leipzig: T. Steinkopff, 1922.) 180 marks.

**Fuchs, W.** Der gegenwärtige Stand des Gärungsproblems. (Sammlung chemischer und chemisch-technischer Vorträge, Band 27.) 4to. Pp. 48. (Stuttgart: F. Enke, 1922.) 12.50 marks.

**Hackspill, L.** La Fixation de l'azote atmosphérique et son avenir industriel. (Encyclopédie Léauté, 2<sup>e</sup> série.) 8vo. Pp. 272. (Paris: Masson et Cie; Gauthier-Villars et Cie, 1922.) 14 francs.

**Hahn, Dr. F.** Leitfaden der quantitativen Analyse. Large 8vo. Pp. viii+230+7 Tafeln. (Dresden und Leipzig: T. Steinkopff, 1922.) 50 marks.

**Harabaszewski, J.** Ćwiczenia laboratoryjne z chemji. 8vo. Pp. 118. (Warschau: E. Wende und Ko., 1922.) 700 mkp.

**Hofmann, Prof. Dr. K. A.** Lehrbuch der anorganischen Chemie. Vierte Auflage. Demy 8vo. Pp. xx+751+7 Tafeln. (Braunschweig: F. Vieweg und Sohn, 1922.) 300 marks; 24s.\*

**Hoimes, Prof. H. N.** Laboratory Manual of Colloid Chemistry. Med. 8vo. Pp. xii+127. (New York: J. Wiley and Sons, Inc.; London: Chapman and Hall, Ltd., 1922.) 10s. net.\*

- Kingzett, G. T.** Chemistry for Beginners and Schools. (With Glossary.) Fourth edition. Gl. 8vo. Pp. vii + 237. (London: Baillière, Tindall and Cox, 1922.) 5s. net.\*
- Lefebure, V.** L'Énigme du Rhin. La stratégie chimique en temps de paix et en temps de guerre. Traduction de l'anglais par M. Thiers. (Collection de mémoires, études et documents pour servir à l'histoire de la guerre mondiale.) 8vo. (Paris: Payot et Cie, 1922.) 7.50 francs.
- Levene, Dr. P. A.** Hexosamines: Their Derivatives, and Mucins and Mucoids. (Monographs of the Rockefeller Institute for Medical Research, No. 18.) Sup. Roy. 8vo. Pp. ii + 104. (New York: Rockefeller Institute for Medical Research, 1922.) 1.25 dollars.\*
- Levin, Prof. Dr. W.** Methodisches Lehrbuch der Chemie und Mineralogie für Realgymnasien und Oberrealschulen. Teil 1. Large 8vo. 4. Auflage. Pp. 115. (Berlin: O. Salle, 1922.) 14 marks.
- Levin, Prof. Dr. W.** Methodischer Leitfaden für den Anfangsunterricht in der Chemie unter Berücksichtigung der Mineralogie. 8. Auflage. 8vo. Pp. iv + 168. (Berlin: O. Salle, 1922.) 16 marks.
- Levin, Prof. Dr. W., and Briecke, Prof. W.** Methodischer Leitfaden der Chemie und Mineralogie für Lyzeen und höhere Mädchenschulen sowie für den Anfangsunterricht in Studienanstalten. 5. Auflage. 8vo. Pp. vii + 160. (Berlin: O. Salle, 1922.) 18 marks.
- Maxwell, T. B.** Étude sur quelques dérivés de la Fenchone. 8vo. Pp. 57. (Paris: Masson et Cie, 1922.)
- Ministry of Munitions and Department of Scientific and Industrial Research.** Technical Records of Explosives Supply, 1915-1918. No. 7: Manufacture of Nitric Acid from Nitre and Sulphuric Acid. Imp. 8vo. Pp. vi + 86. (London: H.M. Stationery Office, 1922.) 10s. 6d. net.\*
- Molinari, Prof. E.** Trattato di chimica generale ed applicata all'industria. Vol. 2: Chimica organica. Parte seconda. Terza edizione riveduta ed ampliata. Med. 8vo. Pp. xv + 625-1406. (Milano: U. Hoepli, 1922.) 48 lire.\*
- Norris, Prof. J. F., and Mark, Prof. K. L.** Laboratory Exercises in Inorganic Chemistry. (International Chemical Series.) Ex. Cr. 8vo. Pp. x + 548 (every second page blank). (London: McGraw-Hill Publishing Co., Ltd., 1922.) 10s. net.\*
- Péchar, E.** Chimie élémentaire. 8vo. Pp. 472. (Paris: Masson et Cie, 1922.)
- Peters, Dr. F. N.** Applied Chemistry. Cr. 8vo. Pp. 461. (St. Louis, Mo.: C. V. Mosby Co., 1922.) 3.50 dollars.
- Quartaroli, A.** Trattato di chimica generale e inorganica. Pp. viii + 640. (Florence: G. C. Sansoni, 1922.) 50 lire.
- Regents** Questions and Answers in Chemistry covering the requirements of High Schools and College Entrance. Pott 8vo. Pp. 94. (New York: Regents Publishing Co., 1922.) 0.60 dollar.
- Rippel, Prof. J.** Grundlinien der Chemie für Oberrealschulen. Teil 2: Organische Chemie. 4. Auflage. 8vo. Pp. viii + 212. (Wien: F. Deuticke, 1921.) 40 marks.
- Schmatolla, O.** Neue Beobachtungen über die anorganischen Nährmittel: Die hauptsächlichsten anorganischen Stützen der menschlichen und tierischen Zell- und Gefäßbildung. Kali-Phosphorsäure-Magnesia-Kalk-Natron. Large 8vo. Pp. 32. (Bad Elmen/Gross Salze: Selbstverlag, 1922.) 8 marks.
- Sears, Prof. G. W.** A Systematic Qualitative Chemical Analysis: A Theoretical and Practical Study of Analytical Reactions of the more common Ions of Inorganic Substances. Med. 8vo. Pp. vi + 119. (New York: J. Wiley and Sons, Inc.; London: Chapman and Hall, Ltd., 1922.) 8s. 6d. net.\*
- Shreve, R. N.,** in collaboration with **Watson, W. N.,** and **Willis, A. R.** Dyes Classified by Intermediates. 8vo. Pp. 631. (New York: Chemical Catalog Co., Inc., 1922.) 10 dollars net.
- Toporescu, E.** Les Entraînements des corps solubles par certains précipités. Pp. 63. (Paris: Editions de 'La Vie universitaire,' 1922.)

- Treadwell, Prof. Dr. F. P.** Kurzes Lehrbuch der analytischen Chemie. In 2 Bänden. Herausgegeben von Prof. W. D. Treadwell. Band 1: Qualitative Analyse. 12. Auflage. 8vo. Pp. xiii + 540 + 3 Tafeln. (Leipzig und Wien: F. Deuticke, 1922.) 192 marks.
- Utermark, Jr., W. L.** Vanille, vanilline, vanille-extracten. (Mededelingen [van het] Koloniaal Instituut te Amsterdam, XXVII.) 8vo. Pp. iii + 116. (Amsterdam: Koloniaal Instituut, 1922.) 2.50 fl.
- Villavecchia, Prof. Dr. G. V.** Trattato di chimica analitica applicata. Metodi e norme per l'esame chimico dei principali prodotti industriali ed alimentari. Seconda edizione riveduta e aumentata. Vol. 2. Pp. 844. (Milano: U. Hoepli, 1922.)
- Vortmann, Prof. Dr. G.** Übungsaufgaben aus der quantitativen chemischen Analyse durch Massanalyse. 3. Auflage. Large 8vo. Pp. 64. (Leipzig und Wien: F. Deuticke, 1922.) 15 marks.
- Wollaston, T. R.** Filtration: An Elementary Treatise on Industrial Methods and Equipment for the Filtration of Liquids and Gases, for those Concerned with Water Supply, Ventilation, and Public Health; Chemists, Mechanical Engineers, and Others. (Pitman's Technical Primers.) Pott 8vo. Pp. x + 102. (London: Sir I. Pitman and Sons, Ltd., 1922.) 2s. 6d. net.\*
- Zieliński, W. J.** Chemie organiczna. 12 rysunek w tekście. 8vo. Pp. 81. (Warschau: Nakł. Trzaski, Everta i Michalskiego, 1922.) 180 mkp.

## Technology

- Blum, A.** Petroleum: Where and How to Find It. Cr. 8vo. Pp. 367. (Chicago: Modern Mining Books Publishing Company; London: D. Appleton and Co., 1922.) 6s. net.
- Broniewski, W.** Zasady metalografji. 8vo. Pp. 724. (Lwów: Księgizna Polska Towarzystwa Nauczyciel Szkół Wyższych, 1922.)
- Conduché, A.** Les Progrés de la métallurgie du cuivre. (Encyclopédie Léauté, 2<sup>e</sup> série.) 8vo. Pp. 266. (Paris: Masson et Cie; Gauthier-Villars et Cie, 1922.) 14 francs.
- Dansaert, G.** Les Anciennes Faïences de Bruxelles: Histoire, fabrication, produits. 4to. Pp. xi + 314. (Bruxelles: G. van Oest et Cie, 1922.) 180 francs.
- Day, Dr. D. T.,** Editor-in-Chief. A Handbook of the Petroleum Industry. In 2 vols. Med. 8vo. Vol. 1: pp. x + 964. Vol. 2: pp. vi + 1006. (New York: J. Wiley and Sons, Inc.; London: Chapman and Hall, Ltd., 1922.) 2 vols., 3l. 15s. net.\*
- Department of Scientific and Industrial Research.** First Report of the Adhesives Research Committee. Med. 8vo. Pp. iv + 129. (London: H.M. Stationery Office, 1922.) 4s. net.\*
- Dosch, A.** Handbuch zur Berechnung der Feuerungen, Dampfkessel, Vorwärmer, Überhitzer, Warmwasser-erzeuger, Kalorifer, Reservoirs usw. 5. Auflage des Handbuches zur Berechnung der Feuerungen usw. Von E. Brauss. (Bibliothek der gesamten Technik, Band 282.) 8vo. Pp. vii + 111. (Leipzig: Dr. M. Jänecke, 1922.) 40 marks.
- Ficher, M. A.** Le Gazogène à fusion des cendres. 8vo. Pp. 46. (Paris: Société des ingénieurs civils de France, 1922.)
- Fischer, Prof. Dr. F.,** Herausgegeben von. Gesammelte Abhandlungen zur Kenntnis der Kohle. Fünfter Band, das Jahr 1920 umfassend. Aus den Arbeiten des Kaiser-Wilhelm-Instituts für Kohlenforschung in Mülheim-Ruhr. Pp. viii + 696. (Berlin: Gebrüder Borntraeger, 1922.) 310 marks.
- Fritsch, J.** Fabrication et raffinage des huiles végétales: Manuel à l'usage des fabricants, raffineurs, courtiers et négociants en huiles. 3<sup>e</sup> édition. Roy. 8vo. Pp. xiii + 723. (Paris: Libr. Desjournes, 1922.)
- Hauge, B.** Materiallaere og materialbehandling. Utarbeidet for teknologisk instituts kursus for smeder. (Statens teknologiske institut.) Pp. 144. (Kristiania: H. Aschehoug, 1922.) 4 kr.
- Hebing, C.** Olfarbe und Olfarbanstriche. 2. Auflage. 8vo. Pp. iii + 155. (München: G. D. W. Callwey, 1922.) 30 marks.

**Hebing, C.** Praktische Anleitung zur Ausführung der Glasätzung in ihren verschiedenen Arten. 3. Auflage. Large 8vo. Pp. 30. (München: G. D. W. Callwey, 1922.) 6 marks.

**Howe, H. M.** La Métallographie de l'acier et de la fonte. Traduit par Octave Hock. 8vo. Pp. 706+45 planches. (Paris et Liège: Ch. Béranger, 1922.) 120 francs.

**Huc, Prof. P.** Manuel du tanneur, mégissier, corroyeur. (Bibliothèque Professionnelle.) Pott 8vo. Pp. 402. (Paris: J.-B. Baillière et Fils, 1922.) 12 francs.\*

**Imperial Institute.** Indian Trade Enquiry: Drugs and Tanning Materials. Reports on Cinchona Bark and Myrobalans. Roy. 8vo. Pp. ix + 59. (London: J. Murray, 1922.) 4s. net.\*

**Kautny, T.** Leitfaden für Acetylschweisser. (Verschmelzen u. Durchbrennen von Metallen.) 6 verb. Auflage. Small 8vo. Pp. vi+246. (Halle a. S.: C. Marhold, 1922.) 26 marks.

**Kirchner, Prof. E.** Die Ganzstoffe der Papierfabrikation. 4to. Pp. iv+342. (Biberach-Riss: Dorn'sche Buchhandlung, 1922.) 150 marks.

**Klenner's** Ziegelhütte. Taschenkalender für die Tonindustrie. Small 8vo. Pp. 240. (München: Verlag der "Süddeutschen Tonindustrie," 1922.) 10 marks.

**Loewer, Prof. E.** Einführung in die Eisenhüttenkunde. (Brief 1.) Large 8vo. Pp. 24. (Potsdam und Leipzig: Bonness und Hachfeld, 1922.) 8 marks.

**Łubkowski, K.** Jedyńie racjonalne określenie ceny torfów opałowych zależnie od procentu wyzyskanego z nich ciepła w praktyce. 8vo. Pp. 54. (Warschau: Wyd. "Polskie Torfy," 1922.) 320 mkp.

**Ludin, Dr. A.** Die Wasserkräfte, ihr Ausbau und ihre wirtschaftliche Ausnutzung. Ein technisch-wirtschaftliches Lehr- und Handbuch. 2 Bänden. 4to. Pp. xvi+1405+11 Tafeln. (Berlin: J. Springer, 1922.) 600 marks.

**Ministère de l'Agriculture.** Direction Générale des Eaux et Forêts. (2<sup>e</sup> Partie.) Service des Grandes Forces Hydrauliques (Région du Sud-Ouest). Résultats obtenus pour le bassin de la Garonne pendant les années 1917-1918. Tome 7, Fascicule C. Sup. Roy. 8vo. Pp. 49+65 Charts. Résultats obtenus pour le bassin de la Garonne. Tome 2 bis, Fascicule C. Sup. Roy. 8vo. Pp. iii+44 Charts. (Paris: Ministère de l'Agriculture, n.d.)\*

**Oortgijsen, M. F.** Mortels en beton. 2 druk. (De technische School, 11.) 8vo. Pp. 128. (Goes: Oosterbaan en Le Coindre, 1922.) 2.25 fl.

**Parnicke, A.** Die maschinellen Hilfsmittel der chemischen Technik. 4. Auflage. Large 8vo. Pp. viii+487. (Berlin: P. Parey, 1922.) 250 marks.

**Paszkowski, K.** Krótki zarys odlewnictwa żeliwa. 101 rysów w tekście. 8vo. Pp. 127. (Warschau: Nakł. Trzaski, Everta i Michalskiego, 1922.) 1200 mkp.

**Pull, E.** The Engineering Workshop Handbook. Fifth edition, revised and enlarged. Pott 8vo. Pp. 175. (London: C. Lockwood and Son, 1922.) 3s. 6d. net.

**Rothschild, Dr. H.** Die süddeutsche Baumwoll-Industrie. 8vo. Pp. 77. (Stuttgart: E. H. Moritz, 1922.) 25 marks.

**Rustproofing Processes:** A Treatise on the Application of Protective Paints and various Zinc-coating and Chemical Processes for Resisting or Preventing the Corrosion of Iron and Steel. (Machinery's Blue Books.) 12mo. Pp. 59. (New York: The Industrial Press, 1921.) 0.50 dollar.

**Sargent, A. J.** Coal in International Trade. Gl. 8vo. Pp. 73. (London: P. S. King and Son, Ltd., 1922.) 2s. 6d. net.

**Scharro, P. W.** Technisch Wordenboek in 4 talen. Nederlandsch — Duitsch — Engelsch — Fransch. Small 8vo. 1: Beton en gewapend beton. Pp. 250. (Amsterdam: Van Mantgen en De Does, 1922.) 3.00 fl.

**Schou, E.** Braendselfproblemet i Danmark under og efter Verdenskrigen med saerligt Henblik paa Torv. . . Large 8vo. Pp. 49. (Stockholm: Gunnar Tisell, 1922.) 2 kr.

**Schramm, H. W.** Praktische Anleitung zur Prüfung aller Malerfarben. (Technische Flugblätter der Deutschen Malerzeitung Die Mappe, No. 7.) 2. Auflage. Large 8vo. Pp. 39. (München: G. D. W. Callwey, 1922.) 10 marks.

**Simmons, Prof. H. E.** Rubber Manufacture: The Cultivation, Chemistry, Testing, and Manufacture of Rubber, with Sections on Reclamation of Rubber and the Manufacture of Rubber Substitutes. 4to. Pp. 146. (London: The Library Press, Ltd., 1922.) 25s. net.

**Simon, E. D., and Fitzgerald, Marion.** The Smokeless City. Demy 8vo. Pp. xi+82. (London: Longmans, Green and Co., 1922.) 1s. 6d.\*

**Stadt Müller, Prof. H.** Die Schmelzöfen der Eisen-, Stahl- und Metallgiesserei. Unter besonderer Berücksichtigung der Bedürfnisse des Maschinenbaues und der gewerblichen Praxis bearbeitet. 2. Auflage. Large 8vo. Pp. xi+325. (Karlsruhe und Leipzig: F. Gutsch, 1922.) 200 marks.

**Strobino, G.** Elementi di tessitura. 8vo. Pp. 295. (Turin: S. Lattes e C., 1922.) 15 lire.

**Urquhart, J. W.** Steel Thermal Treatment. Demy 8vo. Pp. xv+336. (London: C. Lockwood and Son, 1922.) 35s. net.\*

**Virgin, R. Z.** Mine Management: A Practical Handbook for Use in Vocational Schools, Mining Colleges and Universities. 8vo. Pp. 120. (New York: D. Van Nostrand Co., 1922.) 2 dollars.

**Wadleigh, F. R.** Coal Manual. Pp. 184. (Cincinnati: National Coal Mining News, 1922.) 2.50 dollars.

**Walter, G. A.** Die geschichtliche Entwicklung der rheinischen Mineralfarben-Industrie vom Beginn des 19. Jahrhunderts bis zum Ausbruch des Weltkrieges. Ein Beitrag zur rheinischen Industrie-geschichte. (Veröffentlichungen des Archivs für Rheinisch-Westfälische Wirtschaftsgeschichte, Band 6.) 4to. Pp. xx+204. (Essen: G. D. Baedeker, 1922.) 40 marks.

## Meteorology

**Richardson, L. F.** Forms whereon to Write the Numerical Calculations described in "Weather Prediction by Numerical Process." Demy 4to. 23 forms. (Cambridge: At the University Press, 1922.) 2s.\*

## Mineralogy

**Alling, H. L.** The Mineralogy of the Feldspars. 8vo. (Rochester, N.Y.: The Author, 901 East Avenue, 1921.) 1 dollar.

**Berje, F.** Di unterirdiske oerrot: Zalc und naft. 8vo. Pp. 32. (Warschau: Verlag "Kultur-Liga," 1922.) 150 mkp.

**Johannsen, A.** Essentials for the Microscopical Determination of Rock-forming Minerals and Rocks. In thin sections. 4to. Pp. 53. (Cambridge: At the University Press, 1922.) 11s. net.

**Klockmann, F.** Lehrbuch der Mineralogie. 7. und 8. Auflage. Med. 8vo. Pp. xi+667. (Stuttgart: F. Enke, 1922.) 144 marks.

**Weibull, M.** Kortfattad lärobok i mineralogi och geologi. 5 uppl. 8vo. Pp. 42. (Stockholm: Nordstedt och Söner, 1922.) 1.20 kr.

**Zeitschrift für Kristallographie.** Band 57, Heft 1. Large 8vo. Pp. 128. (Leipzig: W. Engelmann, 1922.) 136 marks.

## Geology

**Cole, Prof. G. A. J.** Rocks and their Origins. (Cambridge Manuals of Science and Literature.) Second edition. Fcap. 8vo. Pp. viii+175. (Cambridge: At the University Press, 1922.) 4s. net.\*

**Gregory, Prof. J. W.** Evolution of the Essex Rivers and of the Lower Thames. Demy 8vo. Pp. 68. (Colchester: Benham and Co., Ltd., 1922.) 2s. 6d. net.\*

**Schaffer, Prof. Dr. F. X.** Lehrbuch der Geologie. I Teil: Allgemeine Geologie. Zweite und dritte erweiterte Auflage. Pp. x+504. (Wien und Leipzig: F. Deuticke, 1922.) 250 marks.

**Tyrrell, G. W.** The Pre-Devonian Basement Complex of Central Spitzbergen. (Transactions of the Royal Society of Edinburgh, Vol. 53, Part 1, No. 10.) Med. 4to. Pp. 209-229 + 2 plates. (Edinburgh: R. Grant and Son; London: Williams and Norgate, 1922.) 4s. 6d.\*

**Zimmermann, A.** Die Kalkkögel bei Innsbruck. Ein Führer durch ihr Gebiet. Small 8vo. Pp. 159. (Innsbruck: Universitäts-Verlag Wagner, 1922.) 30 marks.

### Geography: Travel

**Abraham, G. D.** Swiss Mountain Climbs. Cheaper edition. Cr. 8vo. Pp. 447. (London: Mills and Boon, Ltd., 1922.) 7s. 6d. net.

**Barczewski, W.** Rzędne sferycznej geograficznej w geodezji. 8vo. Pp. 35. (Warschau: J. Czerniecki, 1922.) 350 mkp.

**Barns, T. A.** The Wonderland of the Eastern Congo: The Region of the Snow-crowned Volcanoes, the Pygmies, the Giant Gorilla, and the Okapi. Sup. Roy. 8vo. Pp. xxxv+288+plates. (London and New York: G. P. Putnam's Sons, 1922.) 31s. 6d. net.\*

**Brown, W. C.** The Home of Man. Part 5: Australasia. (New Outlook Geography Series.) Cr. 8vo. Pp. 122. (London: G. G. Harrap and Co., Ltd., 1922.) 2s.

**Chambers's Concise Geography of the World.** New edition. Cr. 8vo. Pp. 160. (London and Edinburgh: W. and R. Chambers, Ltd., 1922.) 2s. 6d.

**Chambers's New Geography of the World.** New edition. Cr. 8vo. Pp. 216. (London and Edinburgh: W. and R. Chambers, Ltd., 1922.) 2s.

**Dyott, G. M.** Silent Highways of the Jungle: Being the Record of an Adventurous Journey across Peru to the Amazon. Med. 8vo. Pp. 320. (London: Chapman and Dodd, 1922.) 25s. net.

**Jäggi, Dr. M.** Il Delta della Maggia e la sua vegetazione. (Commissione fitogeografica della Società Elvetica di Scienze Naturali. Contributi allo Studio Geobotanico della Svizzera ro.) Med. 8vo. Pp. 174. (Zurigo, Switzerland: Rascher and Co., 1922.) 7 francs.\*

**Koninklijk Nederlandsch Aardrijkskundig Genootschap.** De Zeeën van Nederlandsch Oost-Indië. Imp. 8vo. Pp. ix+507. (Leiden: E. J. Brill, 1922.)\*

**Muirhead, F.,** Edited by. Wales. (The Blue Guides.) Fcap. 8vo. Pp. lvi+260+22 maps and plans. (London: Macmillan and Co., Ltd.; Paris: Hachette et Cie, 1922.) 7s. 6d. net.

**Regelsperger, G., Pelleray, E., Froment-Guieysse, G.** Notre Domaine Colonial, X: L'Océanie française. 4to. Pp. 158. (Paris: Édition Notre Domaine Colonial, 1922.) 7.50 francs.

### Palaeontology

**Reed, Dr. F. R. C.** Devonian Fossils from Chitral and the Pamirs. (Memoirs of the Geological Survey of India. Palaeontologia Indica, New Series, Vol. 6, Memoir No. 2.) Sup. Roy. 4to. Pp. vii+167+16 plates. (Calcutta: Geological Survey of India, 1922.) 4 rupees.\*

### General Biology: Natural History

**A Woodman.** Wild Nature and Country Life. Cr. 8vo. Pp. 159. (London: T. Fisher Unwin, Ltd., 1922.) 6s. net.\*

**Anglade, M. G.** Le Rôle biologique du chlorure de sodium dans l'organisme. 8vo. Pp. 66. (Thiers: Impr. Favry, 1922.)

**Dunbar of Mochrum, Lady.** The Chow-Chow. Second edition. Pp. xi+78. (London: The Field Press, 1922.) 4s. 6d.

**Galippe et Souffland.** La vie de la matière. Recherches expérimentales. Biologie générale. 8vo. (Paris: A. Maloine et fils, 1922.) 10 francs.

**Goldschmidt, R. A.** Eine Einführung in die Wissenschaft vom Leben für jedermann. Pp. 296. (Leipzig: T. Thomas, 1922.) 60 marks.

**Haecker, Prof. Dr. V.** Über umkehrbare Prozesse in der organischen Welt. (Abhandlungen zur theoretischen Biologie, Heft 15.) Large 8vo. Pp. 39. (Berlin: Gebrüder Borntraeger, 1922.) 21 marks.

**Hewitt, E. R.** Secrets of the Salmon. Roy. 8vo. Pp. 172. (New York and London: C. Scribner's Sons, 1922.) 42s. net.

**Jackmann, Dr. O.** Über die Vorstellbarkeit der direkt bewirkten Anpassungen und der Vererbung erworbener Eigenschaften durch das Prinzip der virtuellen Verschiebungen. Ein Beitrag zur theoretischen Biologie. Pp. iv+124. (Berlin: J. Springer, 1922.) 66 marks.

**Job, H. K.** The Sport of Bird-Study. Demy 8vo. Pp. xiv+312+iv+plates. (New York: The Macmillan Co.; London: Macmillan and Co., Ltd., 1922.) 12s. net.

**Job, H. K.** How to Study Birds: A Practical Guide for Amateur Bird-Lovers and Camera-Hunters. Cr. 8vo. Pp. 272. (New York: The Macmillan Co.; London: Macmillan and Co., Ltd., 1922.) 7s. net.

**Kranichfeld, H.** Die Geltung der von W. Roux und seiner Schule für die ontogenetische Entwicklung nachgewiesenen Gesetzmäßigkeiten auf dem Gebiete der phylogenetischen Entwicklung. Ein Beitrag zur Theorie der Stammesentwicklung (Theorie des phylogenetischen Wachstums). Pp. iv+92. (Berlin: J. Springer, 1922.) 57 marks.

**Lamont, A.** On the Development of the Feathers of the Duck during the Incubation Period. (Transactions of the Royal Society of Edinburgh, Vol. 53, Part 1, No. 11.) Med. 4to. Pp. 231-240+1 plate. (Edinburgh: R. Grant and Son; London: Williams and Norgate, 1922.) 2s.\*

**Lydekker, R.,** Edited by. Royal Natural History. Reissue. 6 vols. Roy. 8vo. (London: F. Warne and Co., 1922.) Half morocco, 147s. net; cloth, 105s. net.

**Ružicka, Prof. Dr. V.** Die allgemeine Biologie als Lehrgegenstand des medizinischen Studiums. Ein Gutachten vorgelegt den Regierungen Mitteleuropas. Pp. ii+30. (Berlin: J. Springer, 1922.) 11s. marks.

**Williamson, H.** The Lone Swallows. Demy 8vo. Pp. ix+245. (London: W. Collins, Sons and Co., Ltd., 1922.) 7s. 6d. net.\*

**Willis, Dr. J. C.** Age and Area: A Study in Geographical Distribution and Origin of Species. With Chapters by Hugo de Vries, H. B. Guppy, Mrs. E. M. Reid, Dr. James Small. Demy 8vo. Pp. x+259. (Cambridge: At the University Press, 1922.) 14s. net.\*

### Botany: Horticulture: Forestry

**Board of Education.** The Botany Gardens of the James Allen's Girls' School, Dulwich: Their History and Organisation. (Educational Pamphlets, No. 41: Educational Experiments in Secondary Schools, No. 5.) Demy 8vo. Pp. 52. (London: H.M. Stationery Office, 1922.) 2s. net.\*

**Hooker, Sir W. J.** Icones Plantarum: Figures, with brief descriptive Characters and Remarks, of New and Rare Plants. Fifth series. Vol. 1, Part 4. 8vo. (London: Dulau and Co., Ltd., 1922.) 10s. net.

**Löhnis, M. P.** Onderzoek over Phytophthora Infestans (Mont.) de by. Op de Aardappelplant. Med. 8vo. Pp. 96+6 plates. (Wageningen: H. Veenman, 1922.)\*

**Ministry of Agriculture and Fisheries.** Sectional Volume No. 1: Collected Leaflets on Fungus Pests and Allied Diseases of Fruit Trees. Demy 8vo. Pp. 60+plate. 8d. net. Sectional Volume No. 2: Collected Leaflets on Insect Pests of Fruit Trees. Demy 8vo. Pp. 100+plates. 10d. net. (London: Ministry of Agriculture and Fisheries, 10 Whitehall Place, 1921.)\*

**Pescott, E. E.** The Dahlia in Australia. Gl. 8vo. Pp. 122. (London: Whitcombe and Tombs, Ltd., 1922.) 3s. 6d. net.

**Rea, C.** British Basidiomycetæ: A Handbook to the Larger British Fungi. (Published under the auspices of the British Mycological Society.) Demy 8vo. Pp. xii+799. (Cambridge: At the University Press, 1922.) 30s. net.\*

**Ridley, H. N.** The Flora of the Malay Peninsula, Vol. 1: Polypetalae. Demy 8vo. Pp. xxxv+918. (London: L. Reeve and Co., Ltd., 1922.) 3l. 3s. net.\*

**Sargent, C. S.** Manual of the Trees of North America (exclusive of Mexico). Second edition. Demy 8vo. Pp. xxvii+910. (London: Constable and Co., Ltd., 1922.) 45s. net.

**Schönlund, Prof. S.** Introduction to South African Cyperaceae. (Botanical Survey of South Africa, Memoir No. 3.) Med. 8vo. Pp. 72+80 plates. (Pretoria: Department of Agriculture, 1922.) 10s. 6d.\*

**Stout, Mrs. G. H.** The Amateur's Book of the Dahlia. Demy 8vo. Pp. xx+314. (London: W. Heinemann, 1922.) 10s. 6d. net.

**Troup, Prof. R. S.** Report on Forestry in Kenya Colony. Fcap. folio. Pp. 47. (London: Crown Agents for the Colonies, 1922.) 5s.\*

**Troup, Prof. R. S.** Report on Forestry in Uganda. Fcap. folio. Pp. 39. (London: Crown Agents for the Colonies, 1922.) 5s.\*

**Wright, H. J.** Plant Pests and Parasites: Preventives and Remedies. ("Country Life" Booklets.) Gl. 8vo. Pp. 32. (London: "Country Life," Ltd.; G. Newnes, Ltd., 1922.) 9d. net.\*

## Zoology

**Abel, O.** Lebensbilder aus der Tierwelt der Vorzeit. Pp. vii+639. (Jena: G. Fischer, 1922.) 120 marks.

**Ditmars, R. L.** Reptiles of the World; Tortoises and Turtles, Crocodilians, Lizards and Snakes of the Eastern and Western Hemispheres. Med. 8vo. Pp. xviii+373+89 plates. (New York: The Macmillan Co.; London: Macmillan and Co., Ltd., 1922.) 18s. net.\*

**Houlbert, C.** Les Coléoptères d'Europe: France et régions voisines. (Encyclopédie scientifique.) Tome 2. Pp. 340+30 plates. Tome 3. Pp. 297+30 plates. (Paris: G. Doin, 1922.) 12 francs le vol.

**Krieg, Dr. H.** Die Prinzipien der Streifenzeichnung bei den Säugetieren. Abgeleitet aus Untersuchungen an den Einhufern. Pp. iv+102. (Berlin: J. Springer, 1922.) 75 marks.

## Agriculture

**Bailey, L. H.**, Edited by. Cyclopedia of Farm Animals. Imp. 8vo. Pp. xvi+708+25 plates. (New York: The Macmillan Company; London: Macmillan and Co., Ltd., 1922.) 25s. net.\*

**Bailey, L. H.**, Edited by. Cyclopedia of Farm Crops: A Popular Survey of Crops and Crop-making Methods in the United States and Canada. Imp. 8vo. Pp. xvi+609+25 plates. (New York: The Macmillan Company; London: Macmillan and Co., Ltd., 1922.) 25s. net.\*

**Barthel, Chr.** Den II Thule Ekspedition til Grønlands Nordkyst 1916-18. Nr. 1: Recherches bactériologiques sur le sol et sur les matières fécales des animaux polaires du Groenland septentrional. Sup. Roy. 8vo. Pp. 75. (Kjøbenhavn: Bianco Lunos Bogtrykkeri, 1922.)\*

**Dmochowski, R.** Podręcznik nauki o nawożeniu. Tom I. Wyd. 2. 8vo. Pp. 401. (Warschau: Selbstverlag des Verfassers, 1922.) 1300 mkp.

**Girard, A.-Ch.** Les Engrais. Emploi raisonné et lucratif. (Nouvelle Bibliothèque du cultivateur.) 8vo. Pp. 164. (Paris: Librairie agricole de la "Maison rustique," 1922.) 4.50 francs.

**Greaves, J. E.** Agricultural Bacteriology. 8vo. Pp. 437. (Philadelphia: Lea and Febiger, 1922.) 4 dollars.

**Heinrich, Prof. Dr. R.** Dünger und Düngen. Anleitung zur praktischen Verwendung von Stall- und Kunstdünger. 8 Auflage. Herausgegeben von Dr. O. Nolte und Dr. M. Heinrich. 8vo. Pp. viii+174. (Berlin: P. Parey, 1922.) 38 marks.

**McKay, Dr. G. L., and Larsen, Prof. G.** Principles and Practice of Butter-making. Third edition, largely rewritten. Med. 8vo. Pp. xiv+405. (New York: J. Wiley and Sons, Inc.; London: Chapman and Hall, Ltd., 1922.) 15s. net.\*

**Ministry of Agriculture and Fisheries.** Sectional Volume No. 3: Collected Leaflets on Cultivation and Diseases of Potatoes. Demy 8vo. Pp. 69+plates. 8d. net. Sectional Volume No. 4: Collected Leaflets on Fruit: Its Cultivation, Marketing and Preservation. Demy 8vo. Pp. 155+plates. 1s. 6d. net. Sectional Volume No. 5. Collected Leaflets on Diseases of Animals. Demy 8vo. Pp. 101+plates. 1s. net. Sectional Volume

No. 6: Collected Leaflets on Weeds. Demy 8vo. Pp. 86+plates. 8d. net. (London: Ministry of Agriculture and Fisheries, 10 Whitehall Place, 1922.)\*

**Pouget, I., Amaric and Léonard.** Esquisse agronomique et agricole de la région de Sétif. 4to. Pp. 73. (Alger: J. Carbonel, 1922.)

**Risler, E., et Wery, G.** Drainage et assainissement des terres. (Encyclopédie agricole.) 4<sup>e</sup> édition. Gl. 8vo. Pp. 384. (Paris: J.-B. Baillière et fils, 1922.)

**Rommel, Lars-Gunnar.** Luftväxlingen i Marken som Ekologisk Faktor: Die Bodenventilation als Ökologischer Faktor. (Meddelanden från Statens Skogsförsöksanstalt, Hälften 19, Nr. 2.) Sup. Roy. 8vo. Pp. 125-359. (Stockholm: Centraltryckeriet, 1922.)\*

**Rouest, L.** Le Soja et son lait végétal: Applications agricoles et industrielles. (Bibliothèque de technique agricole moderne.) 8vo. Pp. iv+157. (Paris: C. Amat, 1921.) 10 francs.

**Scheffer, Dr. F. A.** Leitfaden der Chemie für Landwirte. 2 Auflage. Large 8vo. Pp. 189. (Hannover: M. und H. Schaper, 1921.) 31 marks.

**Wright, D., jr.** Equilibrium Studies with certain Acids and Minerals and their probable relation to the Decomposition of Minerals by Bacteria. (Publications in Agricultural Science, vol. 4, No. 10.) 4to. (Berkeley, Cal.: University of California Press, 1922.) 1.25 dollars.

**Wygoda, B.** Nawozy naturalne. 8vo. Pp. 64. (Lwów: Spółka nakł. "Odrodzenie," 1922.)

## Anatomy: Physiology

**Docker, F. E. M.** The Diet Essential to Health: The value of vitamins. Demy 8vo. Pp. 20. (London: Research and Information Bureau, 1922.) 6d.

**Forster, Prof. A.** La Voûte tarsienne transversale: sa formation et son mécanisme. (6<sup>e</sup> fascicule des "Archives de Morphologie générale et expérimentale.") 8vo. Pp. 188. (Paris: G. Doin, 1922.) 20 francs.

**Haviland, Mary S.** The Most Wonderful House in the World: the Mechanics and Hygiene of the Body. Cr. 8vo. Pp. 204. (London: J. B. Lippincott Co., 1922.) 4s. 6d. net.

**Morton, Dr. W. C.** The Language of Anatomy. Edited, with an Introduction, by Robert Bridges. Correspondence, etc. (S.P.E. Tract No. 9.) Demy 8vo. Pp. 27. (Oxford: Clarendon Press, 1922.) 2s. 6d. net.\*

**Nageotte, Prof. J.** L'Organisation de la matière dans ses rapports avec la vie: Études d'anatomie générale et de morphologie expérimentale sur le tissu conjonctif et le nerf. Roy. 8vo. Pp. vi+560+4 planches. (Paris: F. Alcan, 1922.) 50 francs.\*

**Waller, Dr. A. D.** The Electrical Action of the Human Heart. Edited by A. M. Waller. 8vo. Pp. 111. (London: University of London Press, Ltd., 1922.) 7s. 6d. net.

## Anthropology: Ethnography

**Ameghino, F.** Obras completas y correspondencia Científica. Vol. 3: La Antiquidad del hombre en El Plata. Dirigida por A. J. Torcelli. Sup. Roy. 8vo. Pp. 821. (La Plata: Taller de Impresiones Oficiales, 1915.)\*

**Bouchié de Belle, E.** La Macédoine et les Macédoniens. Pp. 303. (Paris: A. Colin, 1922.) 7 francs.

**MacMichael, H. A.** A History of the Arabs in the Sudan: and some Account of the People who preceded them and of the Tribes inhabiting Darfūr. Med. 8vo. Vol. 1: pp. xxii+347. Vol. 2: pp. viii+488. (Cambridge: At the University Press, 1922.) 2 vols., 4l. 10s. net.\*

**Malinowski, Dr. B.** Argonauts of the Western Pacific: An Account of Native Enterprise and Adventure in the Archipelagoes of Melanesian New Guinea. Roy. 8vo. Pp. xxxii+527+plates. (London: G. Routledge and Sons, Ltd.; New York: E. P. Dutton and Co., 1922.) 21s. net.\*

**Rivers, Dr. W. H. R.,** Edited by. Essays on the Depopulation of Melanesia. Ex. Cr. 8vo. Pp. xx+116. (Cambridge: At the University Press, 1922.) 6s. net.\*

## Philosophy: Psychology

**Achille-Delmas, F., et Boll, M.** La Personnalité humaine: son analyse. (Bibliothèque de Philosophie scientifique.) Pott 8vo. Pp. 284. (Paris: E. Flammarion, 1922.) 7.50 francs.

**Aristotele.** On Coming-to-be and Passing-away. (De Generatione et Corruptione.) A Revised Text. With an Introduction and Commentary by H. H. Joachim. Med. 8vo. Pp. xxxviii+296. (Oxford: Clarendon Press; London: Oxford University Press, 1922.) 32s. net.

**Bergson, H.** Durée et simultanéité: à propos de la théorie d'Einstein. Cr. 8vo. Pp. viii+245. (Paris: F. Alcan, 1922.) 8 francs net.\*

**Bingham, H. C.** Visual Perception of the Chick. (Behavior Monographs, Vol. 4, No. 4, Serial No. 20.) Sup. Roy. 8vo. Pp. vi+104. (Baltimore, Md.: Williams and Wilkins Co., 1922.) 1 dollar.\*

**Brunschvicg, Prof. L.** L'Expérience humaine et la causalité physique. (Bibliothèque de Philosophie contemporaine.) Demy 8vo. Pp. xvi+625. (Paris: F. Alcan, 1922.) 30 francs.\*

**Cody, S.** How to Deal with Human Nature in Business. Fourth edition. Cr. 8vo. Pp. 488. (London: Funk and Wagnalls Co., 1922.) 8s. 6d. net.

**Coupin, H.** Les Petites Idées des grosses bêtes. Pott 8vo. Pp. 320. (Paris: A. Fayard et Cie, 1922.) 6.50 francs.

**Datziell, F. G.** The Truth of Life and Professor Einstein's Theory. Demy 8vo. Pp. 21. (London: Whitcombe and Tombs, Ltd., 1922.) 9d.

**Drennan, C. M.** The Spirit of Modern Criticism: An Essay on Judicial Pragmatism. Demy 8vo. Pp. viii+112. (London: University Tutorial Press, Ltd., 1922.) 2s. 6d.

**Endara, J.** José Ingenieros y el porvenir de la filosofía. 2<sup>a</sup> edición. Pott 8vo. Pp. 100. (Buenos-Aires: Agencia general de Librería, 1922.)

**Freud, S.** Wit and its Relation to the Unconscious. Authorised English edition, with Introduction by A. A. Brill. 8vo. Pp. 397. (London: Kegan Paul and Co., Ltd., 1922.) 12s. 6d. net.

**Hoffmann, Dr. H.** Vererbung und Seelenleben. Einführung in die psychiatrische Konstitutions- und Vererbungslehre. Pp. vi+258. (Berlin: J. Springer, 1922.) 186 marks.

**Homo, L.** Problèmes sociaux de jadis et d'à présent. (Bibliothèque de Philosophie scientifique.) Pott 8vo. Pp. 285. (Paris: E. Flammarion, 1922.) 7.50 francs.

**Kingsland, W.** Our Infinite Life. Cr. 8vo. Pp. 200. (London: G. Allen and Unwin, Ltd., 1922.) 6s. 6d. net.

**Kretschmer, Dr. E.** Körperbau und Charakter. Untersuchungen zum Konstitutionsproblem und zur Lehre von den Temperamenten. Zweite, vermehrte und verbesserte Auflage. Pp. viii+196. (Berlin: J. Springer, 1922.) 84 marks.

**Luce, A. A.** Bergson's Doctrine of Intuition: The Donnellan Lectures for 1921. Cr. 8vo. Pp. 122. (London: S.P.C.K., 1922.) 4s. 6d.

**Munson, E. L.** The Management of Men: A Handbook on the Systematic Development of Morale and the Control of Human Behaviour. Prepared with the literary assistance of Arthur H. Miller. 8vo. Pp. 814. (London: G. G. Harrap and Co., Ltd., 1922.) 21s. net.

**Paton, S.** Human Behaviour in Relation to the Study of Educational, Social, and Ethical Problems. Roy. 8vo. Pp. 465. (London: G. Allen and Unwin, Ltd., 1922.) 21s. net.

**Roloff.** Vergleichend psychologische Untersuchungen über kindliche Definitionsleistungen. Pp. vi+164+2 Tafeln. (Leipzig: J. A. Barth, 1922.) 10 francs.

**Rougier, Prof. L.** Philosophy and the New Physics: An Essay on the Relativity Theory and the Theory of Quanta. Authorised translation from the Author's Corrected Text of "La Matérialisation de l'Énergie" by Prof. M. Masius. Cr. 8vo. Pp. xv+159. (London: G. Routledge and Sons, Ltd., 1922.) 6s. net.\*

**Russell, B.** The Mysticisms and la logique. Traduit de l'anglais par J. de Menascé. Pott 8vo. Pp. 160. (Paris: Payot et Cie, 1922.) 4.50 francs.

**Sopp, Dr. A.** Suggestion und Hypnose. Ihr Wesen, ihre Wirkungen und ihre Bedeutung als Heilmittel. 3. Auflage. Pp. viii+75. (Leipzig: C. Kabitzsch, 1922.) 2 francs.

**Stern, W., and Wiegmann, O.** Methodensammlung zur Intelligenzprüfung von Kindern und Jugendlichen. 2. Auflage. Pp. xii+316. (Leipzig: J. A. Barth, 1922.) 7.50 francs.

**Woods, Charlotte E.** The Self and its Problems: The Blavatsky Lecture for 1919. Cr. 8vo. Pp. 183. (London: Theosophical Publishing House, 1922.) 3s. 6d.

## Bacteriology: Hygiene

**Broeke, A. L. van den.** Het drinkwateronderzoek. (Polytechnische Bibliotheek 43.) 8vo. Pp. 26. (Amsterdam: Van Mantgen en De Does, 1922.) 0.60 fl.

**Klut, Prof. Dr. H.** Untersuchung des Wassers an Ort und Stelle. 4. Auflage. 8vo. Pp. vii+189. (Berlin: J. Springer, 1922.) 45 marks.

**League of Nations.** European Health Conference held at Warsaw from March 20th to 28th, 1922. Fcap. folio. Pp. 41. (London: Constable and Co., Ltd., 1922.) 2s. 6d. net.\*

## Medicine: Surgery

**Arderne, Master John,** Surgeon of Newark. De Arte Phisicali et de Cirurgia. Dated 1412. Translated by Sir D'Arcy Power from a Transcript made by Eric Millar. From the Replica of the Stockholm Manuscript in the Wellcome Historical Medical Museum. Cr. 4to. Pp. xii+60. (London: J. Bale, Sons, and Danielsson, Ltd., 1922.) 10s. 6d. net.

**Ashby, Dr. H. T.** Infant Mortality. (Cambridge Public Health Series.) Second edition. Demy 8vo. Pp. xii+224. (Cambridge: At the University Press, 1922.) 15s. net.\*

**Ashby, H., and Wright, G. A.** Diseases of Children. Revised by H. T. Ashby and C. Roberts. Sixth edition. 8vo. Pp. 769. (London: Oxford University Press, 1922.) 42s. net.

**Ballance, Sir G. A.** A Glimpse into the History of the Surgery of the Brain: The Thomas Vicary Lecture delivered before the Royal College of Surgeons of England on December 8th, 1921. Demy 8vo. Pp. iv+110. (London: Macmillan and Co., Ltd., 1922.) 10s. 6d. net.

**Barker, L. F.,** Edited by. Endocrinology and Metabolism. 4 vols. Roy. 8vo. (London: D. Appleton and Co., 1922.) 240s. net.

**Biesalski, K.** Leitfaden der Krüppelfürsorge. 2. Auflage. Pp. 112. (Leipzig: L. Voss, 1922.) 4.40 francs.

**Brauer, Prof. Dr. L., Schröder, Dr. G., and Blumenfeld, Prof. Dr. F.,** Herausgegeben von. Handbuch der Tuberkulose. In 5 Bänden. Band 4. Pp. iii+780+14 Tafeln. (Leipzig: J. A. Barth, 1922.) 35 francs.

**Brinkley, J. R.** The Brinkley Operation. Cr. 8vo. (Chicago: Sydney B. Flower, 1922.)

**Crocket, J.** Physical Examination of the Chest: with special reference to Pulmonary Tuberculosis. Including a chapter on Tuberculosis of the Larynx. Cr. 8vo. Pp. 259. (London: H. K. Lewis and Co., Ltd., 1922.) 9s. net.

**Friesicke, Dr. G., Capeller, Dr. W., Tschirch, Dr. A.** Rezeptaschenbuch. 4. Auflage. 8vo. Pp. vii+108. (Jena: G. Fischer, 1922.) 18 marks.

**Fulmer, H. C.** The Story of Drugs: A Popular Exposition of their Origin, Preparation, and Commercial Importance. 8vo. Pp. 358. (New York: The Century Co., 1922.) 3 dollars.

**Glässner, Dr. G.** General-Katalog für Apotheken, Drogerien und Grossdrogenhandlungen. 18. Auflage. 4to. Pp. ii+133. (Berlin: Dr. G. Glässner; Wittenberg: A. Ziemson, 1921.) 80 marks.

**Goldberg, Dr.** Kleine Urologie: Leitfaden zur Erkennung und Behandlung der Krankheiten der Harnwege. Pp. vii+140+3 Tafeln. (Leipzig: C. Kabitzsch, 1922.) 7 francs.

**Greimer, Dr. K.** Handbuch des praktischen Desinfektors. Ein Leitfaden für den Unterricht und ein

Nachschlagebuch für die Praxis. 2 Auflage. 8vo. Pp. xxii+197+8 Tafeln. (Dresden und Leipzig: Th. Steinkopff, 1922.) 45 marks.

**Haldane, Dr. J. S.** Respiration. (Silliman Memorial Lectures.) Med. 8vo. Pp. xviii+427. (New Haven: Yale University Press; London: Oxford University Press, 1922.) 28s. net.\*

**Hepburn, M. L.** The Ophthalmology of General Practice. 8vo. Pp. 195. (London: Cassell and Co., Ltd., 1922.) 12s. 6d. net.\*

**Hilton-Simpson, M. W.** Arab Medicine and Surgery: A Study of the Healing Art in Algeria. Demy 8vo. Pp. viii+96+8 plates. (London: Oxford University Press, 1922.) 10s. 6d. net.\*

**Kelly, H. A., and Burnam, C. F.** Diseases of the Kidneys, Ureters, and Bladder. 2 vols. Roy. 8vo. (London: D. Appleton and Co., 1922.) 63s. net.

**Kerr, J. M. M.** Clinical and Operative Gynaecology. (Oxford Medical Publications.) Roy. 8vo. Pp. 832. (London: H. Frowde and Hodder and Stoughton, 1922.) 50s. net.

**Koskowski, B.** Receptura czyli prawida przepisywania i przyrządzania leków. Z 46 rysunkami w tekście. 2 Wyd. 8vo. Pp. v+288. (Warschau: Nakł. Trzaski, Everta i Michalskiego, 1922.) 1500 mkp.

**Laurens, Dr. G.** Oto-rhino-laryngology for the Student and Practitioner. Originally English translation of the fourth revised French edition, by H. Clayton Fox. Second English edition. 8vo. Pp. 352. (Bristol: J. Wright and Sons, Ltd., 1922.) 17s. 6d. net.

**Lemoine, G. H.** Les Services d'hygiène, 1914-18. (Les Questions du temps présent.) Gl 8vo. Pp. iii+280. (Paris: F. Alcan, 1922.) 10 francs.\*

**Leszczynski, R.** Zarys farmakologii. 8vo. Pp. 209. (Lwów: Księgarnia Polska Towarzystwa Nauczyciel Szkół Wyzszych, 1922.) 960 mkp.

**Luchs, Dr. G.** A Text-book on Gonorrhoea and its Complications. Translated and edited by A. Foerster. Third revised edition. Roy. 8vo. Pp. 380. (London: Baillière, Tindall and Cox, 1922.) 21s. net.

**Macdonald, D. M.** The Students' Pocket Prescriber and Guide to Prescription Writing. Seventh edition. 32mo. Pp. 200. (Edinburgh: E. and S. Livingstone, 1922.) 3s. net.

**Mackenzie, Sir J.** L'Avenir de la médecine. Traduit par le Dr. F. Françon. 8vo. Pp. viii+272. (Paris: F. Alcan, 1922.) 12 francs.

**Martius, Dr. H.** Das röntgentherapeutische Instrumentarium. (Handbuch der gesamten medizinischen Anwendungen der Elektrizität einschliesslich der Röntgenlehre. Band 3, Teil 2, Lieferung 1. 4to. Pp. 62. (Leipzig: Dr. W. Klinkhardt, 1922.) 30 marks.

**Pottenger, F. M.** Symptoms of Visceral Disease. Second edition. Roy. 8vo. Pp. 357. (London: H. Kimpton, 1922.) 28s. net.

**Rodenhuis, J.** Handleiding bij het onderzoek naar protozoën in de menschelijke faeces voorkomend. (Mede-deelingen [van het] Koloniaal Instituut, XVI.) 8vo. Pp. iv+68+8 Tafeln. (Amsterdam: Koloniaal Instituut, 1922.) 3 fl.

**Rosenthaler, Prof. Dr. L.** Qualitative pharmazeutische Analyse. Eine Anleitung für Studierende der Pharmazie und Apotheker. 8vo. Pp. viii+192. (Stuttgart: F. Enke, 1922.) 54 marks.

**Salés, G.** Études chimiques et expérimentales sur l'étiologie du choléra infantile et de l'athrepsie, rôle de l'entérocoque. 8vo. Pp. 194. (Paris: Libr. Ollier-Henry, 1922.) 7 francs.

**Schreus, Dr. H. Th.** Grundlagen der Dosimetrie der Röntgenstrahlen. (Handbuch der gesamten medizinischen Anwendungen der Elektrizität einschliesslich der Röntgenlehre. Band 3, Teil 2, Lieferung 2.) 4to. Pp. 4+63-156. (Leipzig: Dr. W. Klinkhardt, 1922.) 45 marks.

**Seifert, Prof. Dr. O.** Die Nebenwirkungen der modernen Arzneimittel. Neuere Arzneimittel in ihrer Zusammensetzung mit besonderer Berücksichtigung ihrer Nebenwirkungen. Teil 2. 4to. Pp. iii+137. (Leipzig: C. Kabitzsch, 1922.) 5 francs.

**Signeux, H.** Contribution à l'étude de l'intoxication carnée. 8vo. Pp. 50. (Paris: Libr. Ollier-Henry, 1922.) 3 francs.

**Singer, C.** Greek Biology and Greek Medicine. (Chapters in the History of Science, I.) Cr. 8vo. Pp. 128. (Oxford: Clarendon Press, 1922.) 2s. 6d. net.\*

**Singer, Dr. C.** The Discovery of the Circulation of the Blood. (Classics of Scientific Method.) Cr. 8vo. Pp. x+80. (London: G. Bell and Sons, Ltd., 1922.) 1s. 6d. net.\*

**Spielmeier, Prof. Dr. W.** Histopathologie des Nervensystems. Erster Band, Allgemeiner Teil. Pp. viii+494. (Berlin: J. Springer, 1922.) 648 marks.

**Tappeiner, Prof. Dr. H. v.** Lehrbuch der Arzneimittel- und Arzneiverordnungslehre. Unter besonderer Berücksichtigung der deutschen und österreichischen Pharmakopie. 15 Auflage. Large 8vo. Pp. viii+576. (Leipzig: F. C. W. Vogel, 1922.) 90 marks.

**Taylor, F. W.** The Practice of Medicine. Twelfth edition, by E. P. Poulton and others. Roy. 8vo. Pp. 995. (London: J. and A. Churchill, 1922.) 30s. net.

**Thoma, K. H.** Oral Roentgenology. Second edition, revised. 4to. Pp. 341. (London: H. Kimpton, 1922.) 30s. net.

**Vincent, Prof. S.** Internal Secretion and the Ductless Glands. Second edition. Demy 8vo. Pp. xx+422. (London: E. Arnold and Co., 1922.) 25s. net.\*

**Wolbach, Prof. S. B.** New Growths and Cancer. (Harvard Health Talks.) Fcap. 8vo. Pp. 53. (Cambridge, Mass.: Harvard University Press; London: Oxford University Press, 1922.) 4s. 6d. net.\*

**Wold, W.** Supplement til Farmakopien. (Rezepturboken II. del.) Pp. 126. (Kristiania: Utgiveren, 1922.) 6 kr.

**Zumbusch, L. V.** Atlas of Syphilis. 4to. (London: J. Bale, Sons, and Danielsson, Ltd., 1922.) 30s. net.

### Miscellaneous

**Annuaire Général de la France et de l'Étranger, 1922.** (Société d'Études et d'Informations économiques.) Cr. 8vo. Pp. xxxii+1118. (Paris: Libr. Larousse, 1922.)\*

**Clarke, W. G.** Our Homeland Prehistoric Antiquities, and How to Study Them. (The Homeland Pocket-Books, No. 13.) Pott 8vo. Pp. 139+plates. (London: The Homeland Association, Ltd., 1922.) 4s. 6d. net.\*

**Dannemann, Dr. F.** Aus der Werkstatt grosser Forscher. Allgemeinverständliche, erl. Abschnitte aus den Werken hervorragender Naturforscher aller Völker und Zeiten. 4 Auflage. Large 8vo. Pp. xii+443. (Leipzig: W. Engelmann, 1922.) 115 marks.

**Department of Scientific and Industrial Research.** Current Meters for Use in River Gauging. Prepared for the Committee on Gauging Rivers and Tidal Currents by Dr. M. A. Hogan. Med. 8vo. Pp. vi+33. (London: H.M. Stationery Office, 1922.) 1s. 6d. net.\*

**Eastman Kodak Company.** Abridged Scientific Publications from the Research Laboratory of the Eastman Kodak Company. Vol. 4, 1919-1920. Pp. 319+xxii. (Rochester, N.Y.: Eastman Kodak Company, 1922.)\*

**Gordon, Mary.** Penal Discipline. Demy 8vo. Pp. xiii+238. (London: G. Routledge and Sons, Ltd.; New York: E. P. Dutton and Co., 1922.) 7s. 6d. net.\*

**Greek Atrocities in Asia Minor.** Published by the Second Section of the General Staff of the Western Front. Cr. 8vo. Pp. 63. (Constantinople: Printing House Husn-I-Tabiat, 1922.)\*

**Günther, H. (W. de Haas).** Technische Träume. Ex. Cr. 8vo. Pp. 83. (Zurich: Rascher et Cie, 1922.) 50 marks.\*

**Kenneth, J. H.** Osmics: The Science of Smell. Demy 8vo. Pp. 42. (Edinburgh: Oliver and Boyd, 1922.) 2s. net.\*

**League of Nations.** Report on the Problem of Raw Materials and Foodstuffs. By Prof. Gini. With Annexes prepared under his direction. Fcap. folio. Pp. 251. (London: Constable and Co., Ltd., 1922.) 10s. net.\*

**Lupton, A.** Happy India as it Might Be if Guided by Modern Science. Cr. 8vo. Pp. 188. (London: G. Allen and Unwin, Ltd., 1922.) 6s. net.\*

**Tomes, B. A.** The Secret Doctrine and Modern Science: The Blavatsky Lecture, 1922. Fcap. 8vo. Pp. 36. (London: Theosophical Publishing House, Ltd., 1922.) 1s.\*



## Recent Scientific and Technical Books

Volumes marked with an asterisk have been received at "NATURE" Office.

## Mathematics

- Charlier, G. V. L.** Vorlesungen über die Grundzüge der mathematischen Statistik. Pp. 125. (Lund: Verlag Scientia, 1922.)
- Hall, H. S., and Stevens, F. H.** A School Geometry. Parts 5-6. Cr. 8vo. Pp. xi+247-442+iv. (London: Macmillan and Co., Ltd., 1922.) 2s. 6d.
- Küster, F. W.** Logarithmische Rechentafeln für Chemiker, Pharmazeuten, Mediziner und Physiker. Nach den gegenwärtigen Stande d. Forschung bearbeitet von Prof. Dr. A. Thiel. 24-26 verbesserte und vermehrte Auflage. 8vo. Pp. 126. (Berlin und Leipzig: W. de Gruyter und Co., 1922.) 40 marks.
- Siceloff, L. P., Wentworth, G., and Smith, D. E.** Analytic Geometry. (Wentworth-Smith Mathematical Series.) Demy 8vo. Pp. vi+290. (Boston and London: Ginn and Co., 1922.) 11s. 6d. net.\*
- Soper, H. E.** Frequency Arrays: Illustrating the Use of Logical Symbols in the Study of Statistical and other Distributions. Demy 8vo. Pp. 48. (Cambridge: At the University Press, 1922.) 3s. 6d. net.\*
- Wentworth, G., Smith, D. E., and Harper, H. D.** Fundamentals of Practical Mathematics. (Wentworth-Smith Mathematical Series.) Cr. 8vo. Pp. vi+202. (Boston and London: Ginn and Co., 1922.) 5s. 6d. net.\*
- Wentworth, G., Smith, D. E., and Harper, H. D.** Machine-Shop Mathematics. (Wentworth-Smith Mathematical Series.) Cr. 8vo. Pp. v+162. (Boston and London: Ginn and Co., 1922.) 5s. 6d. net.\*

## Mechanics: Mechanical Engineering

- Adams, H. C.** Waterworks: for Urban and Rural Districts, with Notes on the Supply for Mansions and Isolated Buildings. Demy 8vo. Pp. x+230. (London: Sir I. Pitman and Sons, Ltd., 1922.) 15s. net.
- Champly, R.** Gazogènes et moteurs à gaz pauvre à la portée de tous. Théorie et pratique du gaz pauvre. Installation et conduite des gazogènes et des moteurs. 2<sup>e</sup> édition. Roy. 8vo. Pp. 232. (Paris: Libr. Desforges, 1922.) 15 francs.
- Devillers, R.** La Dynamique de l'Avion. Pp. 291. (Paris: Libr. Aéronautique, 1922.) 32 francs.
- Dye, F. W.** Steam Heating: A Practical Treatise describing the different Methods or Systems adopted in Warming Buildings by Steam, Low-pressure, Vapour, Vacuum, High-pressure, Reduced pressure, Exhaust Steam, etc., and embracing the available means of Heating Water, and Cooking by Steam. Cr. 8vo. Pp. 212. (London: E. and F. N. Spon, Ltd., 1922.) 8s. 6d. net.
- Jackson, P. G.** Boiler Feed Water: A Concise Handbook for Boiler Feeding Purposes. (Its Effects, Treatment, and Analysis.) Second edition, revised and enlarged. Cr. 8vo. Pp. xi+143. (London: C. Griffin and Co., Ltd., 1922.) 5s. net.
- Painlevé, P.** Les Axiomes de la mécanique (examen critique). (Collection des Maîtres de la Pensée scientifique.) Pp. 112. (Paris: Gauthier-Villars et Cie., 1922.) 3 francs.
- Petit, H.** Les Moteurs. Pp. 190. (Paris: Hachette et Cie., 1922.) 6 francs.
- Smith, L. R.** Industrial Physics: Mechanics. Cr. 8vo. Pp. xi+226. (New York and London: McGraw-Hill Book Co., Inc., 1922.) 8s. 9d.\*
- Stodola, Prof. Dr. A.** Dampf- und Gasturbinen. Mit einem Anhang über die Aussichten der Wärmekraftmaschinen. 5 umgearbeitete und erweiterte Auflage. 4to. Pp. xiv+1111+12 Tafeln. (Berlin: J. Springer, 1922.) 600 marks.
- Swindin, N.** The Flow of Liquids in Pipes. (Chemical Engineering Library.) Gl. 8vo. Pp. 64. (London: Benn Bros., Ltd., 1922.) 3s. net.\*
- Swindin, N.** Pumping in the Chemical Works. (Chemical Engineering Library.) Gl. 8vo. Pp. 80. (London: Benn Bros., Ltd., 1922.) 3s. net.\*

## Physics: Electrical Engineering

- Ballhatchet, A. V.,** Edited by. Wireless Circuits and Connections. Pott 8vo. Pp. 60. (London: P. Marshall and Co., 1922.) 6d. net.
- Born, M.** Der Aufbau der Materie. Drei Aufsätze über moderne Atomistik und Elektronentheorie. Zweite verbesserte Auflage. Pp. vi+86. (Berlin: J. Springer, 1922.) 36 marks.
- Bowker, W. R.** Electrical Circuits and Connections: A Technical, Practical, and Operative Treatise on Direct, Alternating, Polyphase, and Hydro-Electrical Engineering Circuits. Third enlarged edition. Med. 8vo. Pp. xii+211. (London: C. Lockwood and Son, 1922.) 15s. net.
- Broughton, H. H.** The Electrical Handling of Materials: A Manual, in Four Volumes, on the Design, Construction and Application of Cranes, Conveyors, Hoists and Elevators. Vol. 3: Electric Cranes. Ex. Cr. 4to. Pp. xvi+336. (London: Benn Bros., Ltd., 1922.) 50s. net.\*
- Calvert, W. J. R.** Heat. Cr. 8vo. Pp. viii+336. (London: E. Arnold and Co., 1922.) 6s.\*
- Civita, Prof. T. L.** Questions de Mécanica Clássica i Relativista: Conferències donades el Gener de 1921. (Publicacions de l'Institut de Ciències i Col·lecció de Cursos de Física i Matemàtica.) Roy. 8vo. Pp. viii+151. (Barcelona: Institut d'Estudis Catalans.) \*
- Daval, M.** Construction des réseaux d'énergie. (Bibliothèque Professionnelle.) Pott 8vo. Pp. viii+275. (Paris: J.-B. Baillière et Fils, 1922.) 8 francs net.\*
- Gandillot, M.** Véritable interprétation des théories relativistes. Cr. 8vo. Pp. 17. (Paris: Gauthier-Villars et Cie., 1922.)
- Glazebrook, Sir R.,** Edited by. A Dictionary of Physics. Vol. 2: Electricity. Med. 8vo. Pp. vii+1104. (London: Macmillan and Co., Ltd., 1922.) 63s. net.\*
- Häger, H., y Mer, C.** El Microscopio y sus aplicaciones: Manual de microscopía práctica e introducción a las investigaciones microscópicas. Trad. de la 12<sup>a</sup> edición alemana por el Dr. F. Pardoillo. 4to. Pp. 352. (Barcelona: G. Gili, 1922.) 20 pesetas.
- Harris, P. W.** The ABC of Wireless: A Popular Explanation. Gl. 8vo. Pp. 64. (London: The Wireless Press, Ltd., 1922.) 6d. net.\*
- Klaus, Dr. A.** Atome, Elektronen, Quanten. Die Entwicklung der Molekularphysik in elementarer Darstellung. 2 durchgesehene Auflage. 8vo. Pp. 104. (Berlin: Winkelmann und Söhne, 1922.) 47 marks.
- Kraus, Prof. Dr. R., and Uhlenhuth, Prof. Dr. P.,** Herausgegeben von. Handbuch der mikrobiologischen Technik. Band I, Hälfte I. Large 8vo. Pp. 532. (Berlin und Wien: Urban und Schwarzenberg, 1922.) 240 marks.
- Landé, Dr. A.** Fortschritte der Quantentheorie. (Wissenschaftliche Forschungsberichte. Naturwissenschaftliche Reihe, Band 5.) 8vo. Pp. xi+91. (Dresden und Leipzig: Th. Steinkopff, 1922.) 30 marks.
- Schmidt, Dr. H.** Das Weltbild der Relativitätstheorie. Allgemeinverständige Einführung. 3 Auflage. Large 8vo. Pp. viii+139. (Hamburg: P. Hartung, 1922.) 22 marks.
- Scott-Taggart, J.** Wireless Valves Simply Explained. Cr. 8vo. Pp. 134. (London: Sir I. Pitman and Sons, Ltd., 1922.) 3s. net.
- Tumlirz, O.** Die Zustandsausgleichung des flüssigen und dampfförmigen Wassers. Large 8vo. Pp. 93-133. (Wien: A. Hölder, 1921.) 12 marks.
- Tyers, P. D.** The Construction of Wireless Receiving Apparatus. Cr. 8vo. Pp. 76. (London: Sir I. Pitman and Sons, Ltd., 1922.) 1s. 6d. net.
- Verrill, A. H.** Radio for Amateurs: How to Use, Make and Install Wireless Telephone and Telephone Instruments. Cr. 8vo. Pp. xxv+228. (London: W. Heinemann, 1922.) 7s. 6d. net.
- Weiser, M.** Das Atom: eine gemeinverständige Darstellung der neueren Ergebnisse der physikalischen Strahlenforschung. 8vo. Pp. 64. (Dresden: E. Pahl, 1922.) 5 marks.

**Wright, L.** The Microscope: A Practical Handbook. Enlarged and rewritten by A. H. Drew. Cr. 8vo. Pp. 287. (London: Religious Tract Society, 1922.) 5s. net.

### Chemistry

**Andersen, O.** Ildfaste oksydens fysikalske kemi. Oversigt over nyere præcisions-undersøkelser. (Norges geologiske Undersøkelse, Nr. 101.) Pp. 54. (Kristiania: H. Aschehoug and Co., 1922.) 1.50 kr.

**Cohn, Dr. R.** Organische Chemie. (Technische Unterrichtsbücher des Systems Karnack-Hachfeld.) Large 8vo. Pp. 26. (Potsdam and Leipzig: Bonness and Hachfeld, 1922.) 12 marks.

**Davis, R., and Walters, Jr., F. M.** Sensitometry of Photographic Emulsions and a Survey of the Characteristics of Plates and Films of American Manufacture. (Scientific Papers of the Bureau of Standards, No. 439.) Sup. Roy. 8vo. Pp. 120. (Washington: Government Printing Office, 1922.) 35 cents.\*

**Estalalla, J.** Curso de química. 8vo. Pp. 382. (Barcelona: G. Gili, 1921.) 6 pesetas.

**Fehle, Prof. K.** Über die Darstellung des periodischen Systems der chemischen Elemente mittels harmonischer Schwingungen. Large 8vo. Pp. 45. (Freiburg: H. M. Muth, 1922.) 15 marks.

**Francé, R. H.** Streifzüge im Wasserstoff. 18 Auflage. 8vo. Pp. 95. (Stuttgart: Franck'sche Verlag, 1921.) 25.50 marks.

**Freundlich, Prof. Dr. H.** Kapillarchemie. Eine Darstellung der Chemie der Kolloide und verwandter Gebiete. 2 völlig umgearbeitete Auflage. Large 8vo. Pp. xvi+1181. (Leipzig: Akademische Verlagsgesellschaft, 1922.) 400 marks.

**Gruber, M. von.** Über einige Grundregeln des Stoffwechsels. 8vo. Pp. 341-454. (München: G. Franz'scher Verlag, 1922.) 3 marks.

**Guérin, M.** Les Brevets d'invention dans l'industrie chimique. Législation, jurisprudence. 8vo. (Paris: Libr. Dalloz, 1922.) 12 francs.

**Hahn, Dr. H.** Grundriss der Chemie für Techniker. Zugleich einem Repetitorium der Chemie für Studierende der Ingenieur-Wissenschaften. Teil I: Anorganische Chemie. (Bibliothek der gesamten Technik, Band 117.) 2 Auflage. Small 8vo. Pp. 193. (Leipzig: Dr. M. Jänecke, 1922.) 50 marks.

**Haller, A.** Les Actualités de chimie contemporaine. 1<sup>re</sup> série. Cr. 8vo. Pp. 324. (Paris: G. Doin, 1922.)

**Heide, Prof. Dr. C. von der, and Schmitthöner, Dr. F.** Der Wein. Weinbau und Weinbereitung, Chemie und Untersuchung des Weines. 4to. Pp. vi+350. (Braunschweig: F. Vieweg und Sohn, 1922.) 70 marks.

**Lugol, P.** Cours élémentaire de chimie à l'usage de l'enseignement primaire supérieur et des cours complémentaires. Quatrième édition, entièrement refondue. Pp. 392. (Paris: Belin frères.)

**Lunge-Berl.** Chemisch-technische Untersuchungsmethoden. Unter Mitwirkung zahlreicher Fachmänner herausgegeben von Prof. Dr. E. Berl. 2 Band. 7 vollständig umgearbeitete und vermehrte Auflage. Pp. 1411. (Berlin: J. Springer, 1922.) 750 marks.

**McPherson, W., and Henderson, W. E.** Chemistry and its Uses: A Textbook for Secondary Schools. Cr. 8vo. Pp. viii+447. (Boston and London: Ginn and Co., 1922.) 75. 6d. net.\*

**Meyer, Prof. Dr. R.** Vorlesungen über die Geschichte der Chemie. 4to. Pp. viii+167. (Leipzig: Akademische Verlagsgesellschaft, 1922.) 200 marks.

**Ohlmüller, W., and Spitta, O.** Die Untersuchung und Beurteilung des Wassers und des Abwassers. 4 Auflage. Pp. 381. (Berlin: J. Springer, 1922.)

**Ost, Prof. Dr. H.** Lehrbuch der chemischen Technologie. 12 Auflage. Large 8vo. Pp. viii+815+11 Tafeln. (Leipzig: Dr. M. Jänecke, 1922.) 300 marks.

**Ostwald, W.** Prinzipien der Chemie. Eine Einleitung in alle chemischen Lehrbücher. Small 8vo. Pp. xv+540. (Leipzig: Akademische Verlagsgesellschaft, 1922.) 150 marks.

**Pacottet, P., y Guittonneau, L.** Aguardientes y ymagres. 8vo. Pp. 535. (Barcelona: P. Salvat, 1922.) 10 pesetas.

**Pickworth, A.** Corrosion: With special reference to the Ferrous Metals and the Deterioration of Ships. Roy. 8vo. (London: E. and F. N. Spon, Ltd., 1922.) 3s. 6d. net.

**Rohm, Dr. O.** Massanalyse. (Sammlung Göschen, 221.) 2 verbesserte Auflage. Small 8vo. Pp. 96. (Berlin und Leipzig: W. de Gruyter und Co., 1922.) 12 marks.

**Schmidt, E.** Anleitung zur qualitativen Analyse. 9 verbesserte Auflage. Herausgegeben und bearbeitet von Prof. Dr. J. Gadamer. Pp. vi+114. (Berlin: J. Springer, 1922.) 45 marks.

**Schmidt, Prof. Dr. O.** Chemie für Techniker. Leitf. 11. 14 Auflage. Large 8vo. Pp. viii+174. (Stuttgart: K. Wittwer, 1922.) 36 marks.

**Trautz, M.** Lehrbuch der Chemie. Zu eigenem Studium und zum Gebrauch bei Vorlesungen. Erster Band: Stoffe. Pp. xxviii+534. (Berlin und Leipzig: W. de Gruyter und Co., 1922.) 150 marks.

**Ulbrich, O.** Kosmische Chemie. 2 durchgesehene und vermehrte Auflage. 8vo. Pp. 102. (Leipzig: Xenien-Verlag, 1922.) 15 marks.

**Venable, F. P.** Zirconium and its Compounds. (American Chemical Society Monograph Series.) Pp. 173. (New York: Chemical Catalog Co., Inc., 1922.)

### Technology

**Adressbuch der deutschen Gummi-, Asbest- und Cellulose-Industrie und verwandter Geschäftsweize wie Kabel- und Treibriemen-Industrie u.s.w.** Ausgabe 14. 8vo. Pp. 102+662. (Berlin: Union Zweigniederlassung, 1922.) 120 marks.

**Andés, L. E.** Praktisches Rezeptbuch für die gesamte Lack- und Farben-Industrie. Praktische erprobte, aus-erwählte Vorschriften für die Herstellung und Anwendung aller Lacke, Firnisse, Polituren, Anstrichfarben u.s.w. Unentbehrliches Hand- und Hilfsbuch für alle Lack- und Farbenfabriken und Lacke und Farben verarbeitenden Gewerbe. (Chemisch-technische Bibliothek, Band 271.) 3 Auflage. 8vo. Pp. vii+374. (Wien und Leipzig: A. Hartleben, 1922.) 60 marks.

**Bonnaux, H.** La Menuiserie pratique. Tome I: L'outillage. Pott 8vo. Pp. 217. (Paris: E. Flammarion, 1922.)

**Böttner, J.** Obstverarbeitung. Anleitung. 13 Auflage. Bearbeitet von J. Böttner d. J. unter Mitarb. von Obstgutsbesitzer A. Grosch. 8vo. Pp. iv+119. (Frankfurt: Trowitzsch und Sohn, 1922.) 35 marks.

**Cavallier, C.** Notes économiques d'un métallurgiste. Pp. 155. (Paris: Gauthier-Villars et Cie, 1922.) 3.50 francs.

**Desalme, J., et Pierron, L.** Couleurs, peintures et vernis. 2<sup>e</sup> édition. Pott 8vo. Pp. 455. (Paris: J.-B. Baillière et Fils, 1922.) 15 francs.

**Durville, J. P.** Nuevo formulario de perfumes y cosméticos. 8vo. Pp. 534. (Barcelona: G. Gili, 1921.) 14 pesetas.

**Fahion, Dr. W.** Die Fabrikation der Margarine, des Glycerins und Stearins. (Sammlung Göschen, Nr. 829.) (Berlin und Leipzig: W. de Gruyter und Co., 1922.)

**Fierz-David, Prof. Dr. H. E.** Grundlegende Operationen der Farbenchemie. Zweite verbesserte Auflage. Med. 8vo. Pp. xiv+266. (Berlin: J. Springer, 1922.) 300 marks; 12s.\*

**Grey, G. W.** Building Supervision. Second edition. Fcap. 8vo. Pp. 186. (London: E. and F. N. Spon, Ltd., 1922.) 3s. 6d. net.

**Griffiths, H.** The General Principles of Chemical Engineering Design. (Chemical Engineering Library.) Gl. 8vo. Pp. 63. (London: Benn Bros., Ltd., 1922.) 3s. net.\*

**Griffiths, H.** Materials of Chemical Plant Construction—Non-Metals. (Chemical Engineering Library.) Gl. 8vo. Pp. 64. (London: Benn Bros., Ltd., 1922.) 3s. net.\*

**Horner, J. G.** Brassfounding: A Practical Treatise. ("Mechanical World" Series.) Second edition. 8vo. Pp. 220. (London: Emmott and Co., Ltd., 1922.) 7s. 6d. net.

**Isendahl, W., and Kollatz, G. W.** Technisches Taschenwörterbuch in drei Sprachen. Teil 2: Deutsch-englisch-französisch. 2 durchgesehene und verbesserte Auflage. Small 8vo. Pp. 160. (Berlin: G. Siemens, 1922.) 20 marks.

**Jettmar, J.** Pflanzliche Gerbmittel und deren Extrakte. Ein unentbehrlicher Leitfaden für alle Lohgerber und Lederfabrikanten. (Chemisch-technische Bibliothek, Band 370.) 8vo. Pp. viii + 216. (Wien und Leipzig: A. Hartleben, 1922.) 48 marks.

**Kewley, J.** The Petroleum and Allied Industries: Petroleum, Natural Gas, Natural Waxes, Asphalts and Allied Substances, and Shale Oils. (The Industrial Chemistry Series.) Demy 8vo. Pp. xi + 302. (London: Baillière, Tindall and Cox, 1922.) 12s. 6d. net.\*

**Levainville, J. L.** L'Industrie du fer en France. (Collection Armand Colin, No. 19, Section de chimie.) Fcap. 8vo. Pp. vi + 211. (Paris: A. Colin, 1922.) 6 francs.

**Löbel, L.** La technique cinématographique: projection, fabrication des films. Deuxième édition, revue et augmentée. Roy. 8vo. Pp. xvi + 362. (Paris: Libr. Dunod, 1922.) 32 francs.

**Malan, H. L., and Robinson, A. I.** The Weighing and Measuring of Chemical Substances. (Chemical Engineering Library.) Gl. 8vo. Pp. 63. (London: Benn Bros., Ltd., 1922.) 3s. net.\*

**Margival, F.** Les Cirages: Encaustiques, cires à froter, modèler, cacheter, crèmes pour chaussures, mélanges pour entretien des cuirs. (Nouvelle collection des recueils et recettes rationnelles.) Pp. xiv + 275. (Paris: Libr. Desforges, 1922.) 9 francs.

**Martin, A.** Le Pétrole: son origine, sa composition, sa recherche. Adapté de l'anglais. Pott 8vo. (Paris: F. Alcan, 1922.) 6 francs.

**Pfanhauser, Dr. W.** Die elektrolytischen Metallniederschläge. Lehrbuch der Galvanotechnik. 6 wesentlich erweiterte und neubearbeitete Auflage. Large 8vo. Pp. xvi + 832. (Berlin: J. Springer, 1922.) 420 marks.

**Piérard, E.** Principes d'électrotechnie. Tome 3. 3<sup>e</sup> édition. Med. 8vo. Pp. 330. (Paris: Libr. Dunod, 1922.) 26 francs.

**Preger, E.** Die Bearbeitung der Metalle in Maschinenfabriken durch Giessen, Schmieden, Schweißen, Härten und Tempern. (Bibliothek der gesamten Technik, 218.) 6 unveränderte Auflage. 8vo. Pp. viii + 378. (Leipzig: Dr. M. Jänecke, 1922.) 112.50 marks.

**Rouelle, Col. J. L.** L'Acier (élaboration et travail). (Collection Armand Colin, No. 20, Section de chimie.) Fcap. 8vo. Pp. vi + 200. (Paris: A. Colin, 1922.) 6 francs.

**Schäfer, Dr. R.** Die Werkzeugstähle und ihre Wärmebehandlung. Berechtigte deutsche Bearbeitung der Schrift, "The Heat Treatment of Tool Steel," von H. Brearley. 3 verbesserte Auflage. Pp. 324. (Berlin: J. Springer, 1922.) 210 marks.

**Schidrowitz, Dr. P.** Recent Progress in Rubber Chemistry and Technology. Gl. 8vo. Pp. 64. (London: Benn Bros., Ltd., 1922.) 3s. 6d. net.\*

**Summers, A. L.** Anthracite and the Anthracite Industry. (Pitman's Common Commodities and Industries.) Gl. 8vo. Pp. x + 126. (London: Sir I. Pitman and Sons, Ltd., 1922.) 3s. net.\*

**Verstone, P. E.** The Manufacture of Paper Containers: A Textbook on Paper Box and Bag Making. Demy 8vo. Pp. vi + 223 + xlv. (London: Verstone and Co., 1922.) 10s. 6d. net.\*

**Wachter, P.** Die wärmewirtschaftliche und wärmetechnische Literatur. Eine Übersicht. (Das Fachbuch, Band 2.) 8vo. Pp. viii + 212. (München: J. A. Mahr, 1922.) 30 marks.

**Weyrauch, R.** Die Technik. Ihr Wesen und ihre Beziehungen zu anderen Lebensgebieten. Large 8vo. Pp. x + 280. (Stuttgart und Berlin: Deutsche Verlagsanstalt, 1922.) 120 marks.

**World's Directory of Glassworks.** Complete List of all Glass Manufacturers, Glass Refiners, Silverers, Cutters, Exporters, Importers, Dealers, etc. 8vo. Pp. 482. (Leipzig: S. Schnurpfeil Verlagshandlung, 1922.) 500 marks.

**Zerr, G., and Rübenkamp, Dr. R.** Handbuch der Farbenfabrikation. Lehrbuch der Fabrikation, Untersuchung und Verwendung aller in die Praxis vorkommenden Körperfarben. 3 neubearbeitete und vermehrte Auflage. Large 8vo. Pp. xv + 908. (Berlin: Union Zweigniederl., 1922.) 200 marks.

## Astronomy

**Coblentz, W. W.** Tests of Stellar Radiometers and Measurements of the Energy Distribution in the Spectra of 16 Stars. (Scientific Papers of the Bureau of Standards, No. 438.) Sup. Roy. 8vo. Pp. 725-750. (Washington: Government Printing Office, 1922.) 10 cents.\*

## Meteorology

**Elgie, J. H.** How to Forecast the Weather. (Nature Lovers' Library, Vol. 16.) 16mo. Pp. 144. (London: Holden and Hardingham, Ltd., 1922.) 1s. net.\*

**Guilbert, G.** La Prévision scientifique du temps. Pp. 438. (Paris: A. Challamel, 1922.) 22 francs.

## Mineralogy

**Forker, G.** Chemie und Mineralogie: ein Handbuch für Lehrer. (Lebensvoller Unterricht, Band 7.) Large 8vo. Pp. xvi + 432. (Leipzig: Dürrsche Buchhandlung, 1922.) 90 marks.

**Johannsen, Dr. A.** Essentials for the Microscopical Determination of Rock-Forming Minerals and Rocks in Thin Sections. 4to. Pp. vi + 53. (Chicago: University of Chicago Press; London: Cambridge University Press, 1922.) 11s. net.\*

**Rinne, Prof. Dr. F.** Das feinfühlerische Wesen der Materie nach dem Vorbilde der Kristalle. Demy 8vo. 2 und 3 erweiterte Auflage. Pp. viii + 168. (Berlin: Gebrüder Borntraeger, 1922.) 10s. 4d.\*

**Rinne, Prof. Dr. F.** Einführung in die kristallographische Formenlehre und elementare Anleitung zu kristallographisch-optischen sowie röntgenographischen Untersuchungen. 4 und 5 Auflage. Pp. vii + 250 + 3 Tafeln. (Leipzig: Dr. Jänecke, 1922.)

**Wolff, Prof. Dr. F. von.** Einführung in die allgemeine Mineralogie. Kristallographie, Kristallphysik, Mineralchemie. (Wissenschaft und Bildung, 175.) Small 8vo. Pp. viii + 135. (Leipzig: Quelle und Meyer, 1922.) 24 marks.

## Geology

**Agamenone, G.** I Fenomeni Sismici al Vesuvio dal 1892 al 1906. Med. 8vo. Pp. 64. (Modena: Societa Tipografica Modenese, 1922.) \*

**Fenner, E. G.** Everybody's Book of Geology. (Nature Lovers' Library, Vol. 15.) 16mo. Pp. 144. (London: Holden and Hardingham, Ltd., 1922.) 1s. net.\*

**Hall, A. L.** A Bibliography of South African Geology to the End of 1920: Authors' Index. (Geological Survey; Memoir No. 18.) Med. 8vo. Pp. 376. (Pretoria: Government Printing and Stationery Office, 1922.) 10s. 6d.\*

**Hughes, Rev. J. C.** The Geological Story of the Isle of Wight. Cr. 8vo. Pp. ix + 115. (London: E. Stanford, Ltd., 1922.) 5s. net.\*

**Pietzsch, K.** Die geologische Literatur über den Freistaat Sachsen aus der Zeit 1870-1920. Large 8vo. Pp. xii + 232. (Leipzig: G. A. Kaufmann, 1922.) 75 marks.

**Sherlock, Dr. R. L.** Man as a Geological Agent: An Account of his Action on Inanimate Nature. Demy 8vo. Pp. 372. (London: H. F. and G. Witherby, 1922.) 20s. net.\*

## Geography: Travel

**Alder, W. F.** The Isle of Vanishing Men: A Narrative of Adventure in Cannibal-land. Ex. Cr. 8vo. Pp. x + 184. (London: Leonard Parsons, Ltd., 1922.) 8s. 6d. net.

**Berger, P.** Géographie économique générale. Pp. x + 119. (Brussels: Falk fils, 1922.) 5 francs.

**Bourgeois, Général R., and Noirel, Lieut.-Col. H.** Géodésie élémentaire. 2<sup>e</sup> édition revue, corrigée et augmentée. Pp. 460. (Paris: G. Doin, 1922.) 17 francs.

**Bredon, J.** Peking: A Historical and Intimate Description of its Chief Places of Interest. Second edition, revised and enlarged. Demy 8vo. (London: Kegan Paul and Co., Ltd., 1922.) 32s. 6d.

**Cisaf, J., and Pokorný, F.** The Czechoslovak Republic: A Survey of its History and Geography, its Political and Cultural Organisation, and its Economic

Resources. Sup. Roy. 8vo. Pp. vi+218. (London: T. Fisher Unwin, Ltd.; Prague: Orbis Publishing Co., 1922.) 9s. net.\*

**Cresswell, Beatrix F.** The Quantock Hills: Their Combes and Villages. (Homeland Handbooks.) Fourth edition. Cr. 8vo. Pp. 118. (London: Homeland Association, 1922.) 2s. 6d. net.

**Cunningham, E.** Gypsying through Central America. Med. 8vo. Pp. 259. (London: T. Fisher Unwin, Ltd., 1922.) 21s. net.

**Eyre-Todd, G., and Haslehurst, E. W.** Loch Lomond, Loch Katrine and the Trossachs. Described by G. Eyre-Todd; painted by E. W. Haslehurst. 8vo. Pp. 67. (London: Blackie and Co., Ltd., 1922.) 3s. net.

**Gribaudo, P.** Geografia del lavoro. Pp. viii+287. (Turin: Società Editrice Internazionale, 1922.) 15 lire.

**Muirhead, F., and Monmarché, M.,** Edited by North-Eastern France. (The Blue Guides.) Fcap. 8vo. Pp. lxxvi+351+55 maps and plans. (London: Macmillan and Co., Ltd.; Paris: Hachette et Cie., 1922.) 5s. net.

**Ordnance Survey.** The Second Geodetic Survey of England and Wales, 1912-1921. Published by Order of the Ministry of Agriculture and Fisheries, by Col. Sir Charles Close, Director General of the Ordnance Survey, Southampton, 1921. Sup. Roy. 8vo. Pp. 62+46 plates. (London: H.M. Stationery Office, 1922.) 17s. 6d. net.\*

**Swedish Traffic Association.** A Book about Sweden. Cr. 8vo. Pp. 183. (Stockholm: A.-B. Nordiska Bokhandeln, 1922.)\*

**Unstead, Dr. J. F.** The British Isles of To-day. (Citizen of the World Geographies.) Cr. 8vo. Pp. viii+184. (London: Sidgwick and Jackson, Ltd., 1922.) 3s. net.

**Vassal, Gabrielle M.** In and Around Yunnan Fou. Med. 8vo. Pp. x+187. (London: W. Heinemann, 1922.) 10s. 6d. net.

**Wegener, Dr. A.** Die Entstehung der Kontinente und Ozeane. Dritte gänzlich umgearbeitete Auflage. Pp. viii+144. (Braunschweig: F. Vieweg und Sohn, 1922.) 9s.\*

### General Biology: Natural History

**Gordon, S.** Amid Snowy Wastes: Wild Life on the Spitsbergen Archipelago. Med. 8vo. Pp. xiv+206. (London: Cassell and Co., Ltd., 1922.) 15s. net.\*

**Kearton, R.** The Fairy-land of Living Things. New edition. Cr. 8vo. Pp. 182. (London: Cassell and Co., Ltd., 1922.) 5s. net.

**Kearton, R.** Strange Adventures in Dicky-Bird Land. New edition. Cr. 8vo. Pp. 195. (London: Cassell and Co., Ltd., 1922.) 5s. net.

**Kearton, R.** Wild Nature's Ways. With 200 illustrations from photographs by C. and R. Kearton. New edition. 8vo. Pp. 312. (London: Cassell and Co., Ltd., 1922.) 7s. 6d. net.

**Parker, Prof. G. H.** Smell, Taste, and Allied Senses in the Vertebrates. (Monographs on Experimental Biology.) Ex. Cr. 8vo. Pp. 192. (Philadelphia and London: J. B. Lippincott Co., 1922.) 10s. 6d. net.\*

**Reinke, Prof. Dr. J.** Grundlagen einer Biodynamik. (Abhandlungen zur theoretischen Biologie, herausgegeben von Prof. Dr. J. Schaxel, Heft 16.) Roy. 8vo. Pp. v+160. (Berlin: Gebrüder Borntraeger, 1922.) 12s.\*

**Selous, E.** Tommy Smith's Birds. Fcap. 8vo. Pp. x+173. (London: Methuen and Co., Ltd., 1922.) 2s. 6d.

**Sorenson, E. S.** Spotty, the Power Bird, and other Nature Stories: Life Histories of Australian Birds and Animals. Cr. 8vo. Pp. 104. (London: Whitcombe and Tombs, Ltd., 1922.) 5s.

### Botany: Horticulture: Forestry

**Engler, Prof. A., and Prue, Prof. O.,** Herausgegeben von. Die Vegetation der Erde. Sammlung pflanzengeographischer Monographien. XIV. The Vegetation of New Zealand. By Dr. L. Cockayne. Roy. 8vo. Pp. xxiii+304+2 maps+65 plates. (Leipzig: W. Engelmann; New York: G. E. Stechert and Co., 1921.) 1200 marks.\*

**Johnson, Dr. S. G.** Flowering Shrubs and How to Know Them. ("Nature Lovers' Library, Vol. 14.) 16mo. Pp. 128. (London: Holden and Hardingham, Ltd., 1922.) 1s. net.\*

**Linsbauer, Prof. K.,** Herausgegeben von. Handbuch der Pflanzenanatomie unter Mitwirkung zahlreicher Fachmänner. 1 Abteilung, 1 Teil: Cytologie. Band 1: Zelle und Cytoplasma. Von H. Lundegårdh. Sup. Roy. 8vo. Pp. xii+193+102. (Berlin: Gebrüder Borntraeger, 1922.) 24s.\*

**Royal Botanic Gardens, Kew.** Bulletin of Miscellaneous Information. Additional Series IX. The Useful Plants of Nigeria: Part 4. Med. 8vo. Pp. 537-963+vi. (London: H.M. Stationery Office, 1922.) 20s. net.\*

**Schneider, Dr. H.** Die botanische Mikrotechnik. Ein Handbuch des mikroskopischen Arbeitsverfahrens. Von Prof. Dr. A. Zimmermann. 2. Auflage. Large 8vo. Pp. xii+458. (Jena: G. Fischer, 1922.) 120 marks.

**Tansley, A. G.** Elements of Plant Biology. Ex. Cr. 8vo. Pp. 410. (London: G. Allen and Unwin, Ltd.; New York: Dodd, Mead and Co., 1922.) 10s. 6d. net.\*

**Wright, W. P.** A Book About Sweet Peas. 8vo. Pp. 150. (London: Headley Bros., 1922.) 1s. 6d. net.

### Medicine: Surgery

**Audoy, H. J. M.** Les données actuelles de l'étude sur le fonctionnement rénal par l'épreuve de la phénol-sulfonaphthaléine. 8vo. Pp. 42. (Bordeaux: Y. Cadoret, 1922.)

**Ballantyne, J. W.,** Edited by. Encyclopaedia Medica. Second edition. Vol. 8: Labyrinth to Mammary Gland. Folio. Pp. 714. (Edinburgh: W. Green and Son, Ltd., 1922.) 30s. net.

**Blackham, Col. R. J.** Aids to Tropical Hygiene. (Students' Aids series.) Second edition. Pott 8vo. Pp. 247. (London: Baillière, Tindall and Cox, 1922.) 4s. 6d. net.

**Bruck, Prof. Dr. G.** Rezepttaschenbuch für Dermatologen. Small 8vo. Pp. iv+156. (Berlin: J. Springer, 1922.) 48 marks.

**Collet, N.** De l'emploi des injections sous-cutanées de sels arsénicaux dans le traitement de la syphilis nerveuse. 8vo. Pp. 32. (Paris: Libr. Le François, 1922.)

**Démelin, L.** Traitement de la syphilis par le bismuth. 8vo. Pp. 62. (Paris: J. Vanderperre, 1922.)

**History of the Great War:** Based on Official Documents. Medical Services. Diseases of the War. Vol. I. Edited by Major-General Sir W. G. MacPherson, Major-General Sir W. P. Herringham, Col. T. R. Elliott, and Lt.-Col. A. Balfour. Med. 8vo. Pp. viii+550. (London: H.M. Stationery Office, 1922.) 21s. net.\*

**Hugel, Delater et Zoeller.** Comment interpréter en clinique les réponses du laboratoire. 8vo. Pp. 143. (Paris: A. Maloine et fils, 1922.)

**Lacombe, J.** Sérothérapie intrarachéale des infections associées dans la tuberculose pulmonaire. 8vo. Pp. 119. (Nancy: A. Colin, 1922.)

**Leclerc, Dr. H.** Précis de phytothérapie. Pp. 297. (Paris: Masson et Cie, 1922.) 12 francs.

**Lewin, Prof. Dr. L.** Die Fruchtabtreibung durch Gifte und andere Mittel. Ein Handbuch für Ärzte und Juristen. 3 neugestaltete und vermehrte Auflage. Large 8vo. Pp. viii+450. (Berlin: J. Springer, 1922.) 196 marks.

**Paret, J.** Traitement des ulcérations tuberculeuses de la peau et des muqueuses par les rayons X. 8vo. Pp. 17. (Trévoux: J. Jeannin, 1922.)

**Platz, H.** Über Kapillaranalyse und ihre Anwendung im pharmazeutischen Laboratorium. Pp. 42+8 Tafeln. (Leipzig: Dr. W. Schwabe, 1922.) 60 marks.

**Popovitch, V.** Vaccino-thérapie dans l'ostéomyélite. 8vo. Pp. 63. (Trévoux: J. Jeannin, 1922.)

**Schmidt, Dr. H.** Das Antimon in der neueren Medizin. Die Literatur 1906-1921 in Referaten. (Archiv für Schiffs- und Tropen-Hygiene, Pathologie und Therapie exot. Krankheiten, Beiheft 1922, Beih. I.) Large 8vo. Pp. 68. (Leipzig: J. A. Barth, 1922.) 30 marks.

**Stockert, Dr. K.,** Herausgegeben von. Lehrbuch für Drogisten. 4to. Pp. viii+432. (Wien und Leipzig: C. Fromme, 1922.) 80 marks.

**Weil, A.** Die innere Sekretion. Eine Einführung für Studierende und Ärzte. 2 verbesserte Auflage. Large 8vo. Pp. v+146. (Berlin: J. Springer, 1922.) 36 marks.

## Recent Scientific and Technical Books

Volumes marked with an asterisk have been received at "NATURE" Office.

## Mathematics

**Aliotta, A.** Teoria di Einstein: Le mutevoli prospettive del mondo. Fcap. 8vo. Pp. 130. (Palermo: R. Sandron, 1922.) 6 lire.

**Aquino, L. d'.** Il fondamento, il contenuto, le conseguenze della nuova teoria della relatività: esposizione critica elementare. 8vo. Pp. 18. (Napoli: Detken e Rocholl, 1922.) 3.50 lire.

**Beer, Dr. F.** Die Einsteinsche Relativitätstheorie und ihr historisches Fundament. 7 Auflage. 8vo. Pp. 80. (Wien und Leipzig: M. Perles, 1922.) 17 marks.

**Borel, E.** Méthodes et problèmes de la théorie des fonctions. (Collection de Monographies sur la théorie des fonctions.) Roy. 8vo. Pp. x+148. (Paris: Gauthier-Villars et Cie, 1922.) 12 francs.\*

**Boucharde, J.** Tables centésimales pour le tracé des courbes, chemins de fer, routes, canaux, etc. 8vo. Pp. xii+204. (Paris: Gauthier-Villars et Cie, 1922.) 15 francs.

**Brahm, Dr. Ed.** Exercices méthodiques du calcul intégral. 4<sup>e</sup> édition. 8vo. Pp. viii+302. (Paris: Gauthier-Villars et Cie, 1922.) 12.50 francs.

**Breitensteiner Repetitorium.** Nr. 57: Repetitorium der höheren Mathematik. Erster Teil: Differentialrechnung. Von F. Hüneke, 2 neuverfasste Auflage. Pp. vi+160. (Leipzig: J. A. Barth, 1922.) 110 marks.

**Carson, G. St. L., and Smith, Prof. D. E.** First Ideas of Geometry. Being Part I. Section 1 of the authors' "Plane Geometry." Gl. 8vo. Pp. vi+90. (London and Boston: Ginn and Co., 1922.) 1s. 6d. net.

**Christesco, S.** Systèmes cellulaires des mondes: Explorations dans l'ultra-éther de l'univers et les anomalies des théories d'Einstein. Précédé d'un Atlas de cosmologie scientifique. 8vo. Pp. 440. (Paris: F. Alcan, 1922.) 30 francs net.

**Comrie, P., and Woodburn, W.** Chambers's New Commercial Arithmetic. Gl. 8vo. Part 2. Pp. 176. (London and Edinburgh: W. and R. Chambers, Ltd., 1922.) 2s.

**Curzon, Dr. H. E. J.** A Course in Elementary Mathematics for Schools. (Organised Mathematics Series.) Cr. 8vo. Book 3. Pp. 88. 2s. 6d. net; with Answers, 3s. net. Book 4. Pp. 111. 2s. 9d. net; with Answers, 3s. 3d. net. (London, Bombay, and Sydney: Constable and Co., Ltd., 1922.)\*

**Dakin, A.** Examples in Practical Mathematics for Technical and Secondary Schools. Cr. 8vo. Pp. viii+143+xxi. (London: G. Bell and Sons, Ltd., 1922.) 2s. 6d.\*

**Dingler, Prof. Dr. H.** Relativitätstheorie und Ökonomieprinzip. Ex. Cr. 8vo. Pp. 77. (Leipzig: S. Hirzel, 1922.) 12 marks.\*

**Einstein, A.** Vier Vorlesungen über Relativitätstheorie, gehalten im Mai 1922 an der Universität Princeton. Large 8vo. Pp. iii+70. (Braunschweig: F. Vieweg und Sohn, 1922.) 12 marks.

**Foster, V. Le Neve.** Geometry Practical and Theoretical. *Pari Passu.* In 3 vols. Vol. 3: Solid Geometry. (Bell's Mathematical Series for Schools and Colleges.) Cr. 8vo. Pp. xiv+423-585+vi. (London: G. Bell and Sons., Ltd., 1922.) 3s. 6d.\*

**Hall, H. S., and Stevens, F. H.** An Elementary Course of Mathematics: comprising Arithmetic, Algebra, and Geometry. A new edition, including a Full Treatment of Easy Graphs. Gl. 8vo. Pp. xv+98+150+136+64. (London: Macmillan and Co., Ltd., 1922.) 3s. 6d.

**Hirschfeld, Dr.** Hauptbuch zur ärztlichen Buchführung. Dritte unveränderte Auflage. 4to. Pp. 208. (Leipzig: C. Kabitzsch, 1923.) 320 marks.

**Hurwitz, Prof. A.** Vorlesungen über allgemeine Funktionentheorie und elliptische Funktionen. Herausgegeben und ergänzt durch einen Abschnitt über: Geometrische Funktionentheorie von Prof. C. Courant. (Die

Grundlehren der mathematischen Wissenschaften in Einzeldarstellungen, Band 3.) Pp. xii+400. (Berlin: J. Springer, 1922.) 318 marks.

**Innes, R. T. A.** Elliptic Expansions. (Proceedings of the Royal Society of Edinburgh, Session 1921-1922. Vol. 42, Part 3, No. 19.) Sup. Roy. 8vo. (Edinburgh: R. Grant and Son; London: Williams and Norgate, 1922.) 6d.\*

**Keal, H. M., and others.** Tables for Technical Mathematics. Cr. 8vo. Pp. 85. (London: Chapman and Hall, Ltd., 1922.) 4s. net.

**Kirkwood, J.** Farm Book-keeping: the Principles and Practice of Book-keeping applied to Agriculture, for Agricultural Classes, Evening Classes and Practical Farmers. Gl. 8vo. Pp. 224. (Edinburgh: W. Green and Son, Ltd., 1922.) 6s. net.\*

**Phillips, Prof. H. B.** Differential Equations. Cr. 8vo. Pp. vi+78. (New York: J. Wiley and Sons, Inc.; London: Chapman and Hall, Ltd., 1922.) 6s. 6d. net.\*

**Riley, E., and Riley, J.** An Arithmetic of Citizenship. Gl. 8vo. Pp. iv+124+30. (London: Sidgwick and Jackson, Ltd., 1922.) 2s. 6d. net.

**Sauger, M.** Einstein ou Euclide. Gl. 8vo. Pp. 21. (Paris: Les Presses Universitaires de France, 1922.) 2.50 francs.\*

**Silberstein, Dr. L.** Bell's Mathematical Tables: Together with a Collection of Mathematical Formulae, Definitions, and Theorems. Demy 8vo. Pp. xi+250. (London: G. Bell and Sons, Ltd., 1922.) 16s. net.\*

**Stoffaës, Prof. l'abbé.** Cours de mathématiques supérieures, à l'usage des candidats à la Licence ès sciences physiques. 4<sup>e</sup> édition entièrement refondue. 4to. Pp. 489. (Paris: Gauthier-Villars et Cie, 1922.) 45 francs.

**Yule, G. Udny.** An Introduction to the Theory of Statistics. (Griffin's Scientific Textbooks.) Sixth edition, enlarged. Cr. 8vo. Pp. 430. (London: C. Griffin and Co., Ltd., 1922.) 12s. 6d. net.

## Mechanics: Mechanical Engineering

**Autenrieth, Ed.** Technische Mechanik: Ein Lehrbuch der Statik und Dynamik für Ingenieure, neu bearbeitet von Dr. Max Ensslin. Dritte verbesserte Auflage. Med. 8vo. Pp. xv+564. (Berlin: J. Springer, 1922.) 300 marks.

**Chalkley, A. P.** The Diesel Engine for Land and Marine Purposes. Fifth edition, revised and enlarged. Demy 8vo. Pp. xxvii+330. (London: Constable and Co., Ltd., 1922.) 21s. net.

**Chapman, Prof. L. B.** The Marine Power Plant. Med. 8vo. Pp. viii+320. (New York and London: McGraw-Hill Book Co. Inc., 1922.) 20s.\*

**Croft, T.** Steam-Engine Principles and Practice. Ex. Cr. 8vo. Pp. xiii+513. (New York and London: McGraw-Hill Book Co. Inc., 1922.) 17s. 6d.\*

**Duval, Lieut. A.-B., et Hébrard, Capt. L.** Traité pratique de navigation aérienne. 4to. Pp. 60. (Paris: Gauthier-Villars et Cie, 1922.) 6 francs.

**Frache, G.** Manuel de l'ouvrier mécanicien. 10 volumes. Tome I: Mécanique générale. Carnet du mécanicien. 5<sup>e</sup> édition, revue et considérablement augmentée. Fcap. 8vo. Pp. 250. (Paris: Gauthier-Villars et Cie, 1922.) 9 francs.

**Frémont, Ch.** Causes de ruptures accidentelles des rails. 4to. Pp. 32. (Paris: Libr. Dunod, 1922.) 10 francs.

**Good, F. F.** Automobile Laboratory Manual: Projects for the Study of Engines, Carburetors, Electrical Systems and Mechanisms, their Construction, Operation, Adjustment, and Repair. Cr. 8vo. Pp. xiii+186. (New York and London: McGraw-Hill Book Co., Inc., 1922.) 7s. 6d.\*

- Gouard, Prof. E., et Herniaux, Prof. G.** Cours élémentaire de mécanique industrielle. Tome I, 2<sup>e</sup> édition. Nouveau tirage. Ex. Cr. 8vo. Pp. 386. (Paris: Libr. Dunod, 1922.) 12 francs.
- Haler, P. J., and Stuart, A. H.** A Second Course in Engineering Science. Gl. 8vo. Pp. vii + 250. (London: University Tutorial Press, Ltd., 1922.) 55.\*
- Lamotte, Prof. M.** Cours de mécanique appliquée. Roy. 8vo. Pp. 282. (Paris: Gauthier-Villars et Cie, 1922.) 25 francs.
- Magnel, G.** Calcul pratique des poutres continues en béton armé, en tenant compte de la raideur des colonnes. Roy. 8vo. Pp. 62 + 11 planches. (Paris: Gauthier-Villars et Cie, 1922.) 30 francs.
- Pacoret, E.** Appareils de levage de manutention et de transports mécaniques industriels. Roy. 8vo. Tome I: Technique et données de construction et de fonctionnement. Pp. xii + 808. 65 francs. Tome II: Applications aux industries diverses. Pp. 235. 20 francs. (Paris: Libr. Dunod, 1922.)
- Planck, Prof. Dr. M.** Einführung in die Mechanik deformierbarer Körper. Large 8vo. Pp. v + 193. (Leipzig: S. Hirzel, 1922.) 42 marks.
- Ricardo, H. R.** The Internal-Combustion Engine. Vol. I: Slow-speed Engines. Roy. 8vo. Pp. vii + 488. (London and Glasgow: Blackie and Son, Ltd., 1922.) 30s. net.\*
- "Road Rider."** Tracing Motor-cycle Troubles. Fifth edition. Including Special Sections on the Two-stroke Engine and Dynamo Lighting Sets. Cr. 8vo. (London: Iliffe and Sons, Ltd., 1922.) 2s. net.
- Seufert, F.** Dampfkessel und Dampfmaschinen: Ein Lehrbuch, 9 verbesserte Auflage. Large 8vo. Pp. x + 285. (Leipzig: J. J. Weber, 1922.) 145 marks.
- Steuer, Dr. C.** Die Wärmekraftmaschinen: Ein Lehrbuch, 3. Auflage. Large 8vo. Pp. viii + 320 + 7 Tafeln. (Leipzig: O. Leiner, 1922.) 84 marks.
- Vacuum Automatic Brake, The.** With a note on "Shipping Carriages." 8vo. Pp. 116. (London: Locomotive Publishing Co., Ltd., 1922.) 2s. 6d. net.
- Westinghouse Air Brake, The:** a Description of the System and its Working. Cr. 8vo. Pp. 80. (London: Locomotive Publishing Co., Ltd., 1922.) 2s. 6d. net.

### Physics: Electrical Engineering

- Aigner, F.** Unterwasserschalltechnik. Grundlagen, Ziele und Grenzen. (Submarine Akustik in Theorie und Praxis.) Large 8vo. Pp. 322. (Berlin: M. Krayn, 1922.) 100 marks.
- Alliata, G.** Die Radioaktivität im Weltbild der Äthermechanik. Large 8vo. Pp. 14. (Leipzig: O. Hillmann, 1922.) 6 marks.
- Alliata, G.** Das Weltbild der Äthermechanik. (Skizze zum Weltbild.) 8vo. Pp. 57. (Leipzig: O. Hillmann, 1922.) 15 marks.
- Arnold, Prof. Dr. E.,** Herausgegeben von. Die Wechselstromtechnik. Erster Band: Theorie der Wechselströme. Von J. L. la Cour und Prof. O. S. Bragstad. Zweite vollständig umgearbeitete Auflage. Unveränderter Neudruck. Pp. xiv + 922. 720 marks. Zweiter Band: Die Transformatoren: Ihre Theorie, Konstruktion, Berechnung und Arbeitsweise. Von E. Arnold und J. L. la Cour. Zweite vollständig umgearbeitete Auflage. Unveränderter Neudruck. Pp. xii + 450 + 6 Tafeln. 360 marks. Dritter Band: Die Wicklungen der Wechselstrommaschinen. Von E. Arnold. Zweite vollständig umgearbeitete Auflage. Unveränderter Neudruck. Pp. xiii + 372 + 5 Tafeln. 300 marks. Vierter Band: Die synchronen Wechselstrommaschinen, Generatoren, Motoren und Umformer: Ihre Theorie, Konstruktion, Berechnung und Arbeitsweise. Von E. Arnold und J. L. la Cour. Zweite vollständig umgearbeitete Auflage. Unveränderter Neudruck. Pp. xx + 896 + 18 Tafeln. 720 marks. Fünfter Band: Die asynchronen Wechselstrommaschinen. 1 Teil: Die Induktionsmaschinen: Ihre Theorie, Berechnung, Konstruktion und Arbeitsweise. Von E. Arnold und J. L. la Cour, unter Mitarbeit von A. Fraenckel. Unveränderter Neudruck. Pp. xvi + 614 + 10 Tafeln. 480 marks. 2 Teil: Die Wechselstromkommutatormaschinen: Ihre Theorie, Berechnung, Konstruktion und Arbeitsweise. Von E. Arnold, J. L. la Cour und A. Fraenckel. Unveränderter Neudruck. Pp. xvi + 660 + 6 Tafeln. 480 marks. (Berlin: J. Springer, 1922.)
- Bangert, Prof. Dr. K.** Masse und Masssysteme mit besonderer Berücksichtigung der Elektrotechnik. 8vo. Pp. viii + 110. (Leipzig: Kesselring'sche Hofbuchhandlung, 1922.) 22.50 marks.
- Bohr, N.** Drei Aufsätze über Spektren und Atombau. (Sammlung Vieweg, Heft 56.) 8vo. Pp. vii + 148. (Braunschweig: F. Vieweg und Sohn, 1922.) 24 marks.
- Born, M.** Die Relativitätstheorie Einsteins und ihre physikalischen Grundlagen. ("Naturwissenschaftliche Monographien und Lehrbücher," Band III.) Dritte verbesserte Auflage. Pp. xii + 268. (Berlin: J. Springer, 1922.) 159 marks.
- Brown, H. G.** The Lead Storage Battery. 8vo. Pp. 162. (London: Locomotive Publishing Co., Ltd., 1922.) 5s. net.
- Bull, J.** Elektrisk metalsmelting. Forsök og undersökelse utförd ved marinsens torpedo-og minefabrik i samarbeide med statens raastofkomité. (Norges geologiske Undersökelse, Nr. 104.) Pp. 28. (Kristiania: H. Aschehug and Co., 1922.) 0.75 kr.
- Caillault, R., et Baud, C.** La Technique du métier d'électricien. Deuxième édition. Ex. Cr. 8vo. Pp. viii + 256. (Paris: Libr. Dunod, 1922.) 9 francs.
- Collins, A. F.** The Book of the Wireless Telegraph and Telephone: Being a Clear Description of Wireless Telegraph and Telephone Sets and how to Make and Operate them; together with a Simple Explanation of how Wireless works. Cr. 8vo. Pp. xv + 227. (London: D. Appleton and Co., 1922.) 6s. net.
- Duport, Prof. L.** La Loi de l'attraction universelle. Roy. 8vo. Pp. 36. (Paris: Gauthier-Villars et Cie, 1922.) 6 francs.
- Eversmann, G. D. C., en Hammes, J.** Galvaniseeren: Handleiding ten gebruike bij de verwaardiging en bewerking van electrolytische (galvanische) metaalbeslagen, als vernikkeling, verkoperen, verzilveren, enz. 8vo. Pp. vii + 288. (Amsterdam: N. V. Wed. J. Ahrend en Zoon, 1922.) 0.75 fl.
- Fison, Dr. A. H.** A First Year's Course in Practical Physics. Cr. 8vo. Pp. 156. (London: E. Arnold and Co., 1922.) 5s.\*
- Foote, P. D., and Mohler, F. L.** The Origin of Spectra. (American Chemical Society Monograph Series.) Med. 8vo. Pp. 250. (New York: Chemical Catalog Co., Inc., 1922.) 4.50 dollars net.\*
- Fowle, F. F.,** Editor-in-chief. Standard Handbook for Electrical Engineers. Prepared by a Staff of Specialists. Fifth edition, thoroughly revised. Fcap. 8vo. Pp. xviii + 2137. (New York and London: McGraw-Hill Book Co., Inc., 1922.) 30s.\*
- Fuchs, L.** Grundriss der Funkentelegraphie in gemeinverständlicher Darstellung. 12. Auflage. Med. 8vo. Pp. 94. (München und Berlin: R. Oldenbourg, 1922.) 40 marks.
- Grassi, G.** Corso di elettrotecnica. 6 edizione. 8vo. Pp. 271. (Turin: Società Tipografico-Editrice Nazionale, 1922.) 30 lire.
- Gray, Dr. J. G., and Gray, Capt. J.** On the Application of the Gyroscope to the Solution of the "Vertical" Problem on Aircraft. Part I. (Proceedings of the Royal Society of Edinburgh, Session 1921-1922, Vol. 42, Part 3, No. 18.) Sup. Roy. 8vo. Pp. 257-317. (Edinburgh: R. Grant and Son; London: Williams and Norgate, 1922.) 6s. 6d.\*
- Guye, Ch. E.** L'Évolution physico-chimique: La relativité d'Einstein dans la classification des sciences: L'évolution physico-chimique et les probabilités: Le principe de Carnot envisagé dans les organismes vivants. (Bibliothèque de synthèse scientifique.) 8vo. Pp. 116. (Paris: Et. Chiron, 1922.) 5 francs.
- Hoppe, F.** Elektrotechnische Messinstrumente und Messmethoden. 8vo. Pp. 75. (Berlin: R. C. Schmidt und Co., 1922.) 20 marks.
- Janet, Prof. P.** Leçons d'électrotechnique générale. Trois volumes. Roy. 8vo. Tome II: Courants alternatifs sinusoidaux et non sinusoidaux; Alternateurs; Transformateurs. 5<sup>e</sup> édition, revue et augmentée. Pp. 452. (Paris: Gauthier-Villars et Cie, 1922.) 40 francs.

**Kirchberger, Prof. Dr. P.** Die Entwicklung der Atomtheorie. 8vo. Pp. x+260. (Karlsruhe: C. F. Müller, 1922.) 60 marks.

**Kossel, W.** Les Forces de valence et les spectres de Röntgen. Traduit par M. Golay. Large 8vo. Pp. 70. (Paris: A. Blanchard, 1922.) 4.50 francs.

**Kretzschmar, F. E.** Die Krankheiten des Blei-Akkumulators: ihre Entstehung, Feststellung, Beseitigung, Verhütung. 2 verbesserte Auflage. 8vo. Pp. viii+176. (München und Berlin: R. Oldenbourg, 1922.) 40 marks.

**Laffargue, J., et Jumau, L.** Manuel pratique du montage électrique. 1<sup>re</sup> édition entièrement refondue et mise à jour. 8vo. Pp. 1030+5 planches. (Paris: Gauthier-Villars et Cie, 1922.) 30 francs.

**Lescarboura, A. G.** Radio for Everybody. Edited by R. L. Smith-Rose. Cr. 8vo. Pp. xii+308. (London: Methuen and Co., Ltd., 1922.) 7s. 6d. net.\*

**Loisel, P.** Recherches sur la radio-activité des eaux des Bagnols-de-l'Orne. 8vo. Pp. 116. (Paris: Impr. édition de l'Expansion scientifique française, 1922.)

**Lombardi, L.** Corso teorico-pratico di elettrotecnica. Vol. I. 3 edizione. 8vo. Pp. xii+624. (Milano: F. Vallardi, 1922.)

**Mottelay, Dr. P. F.**, Compiled by. Bibliographical History of Electricity and Magnetism: Chronologically arranged. Researches into the Domain of the Early Sciences, especially from the period of the Revival of Scholasticism; with Biographical and other Accounts of the most Distinguished Natural Philosophers throughout the Middle Ages. Roy. 8vo. Pp. xx+673. (London: C. Griffin and Co., Ltd., 1922.) 42s. net.\*

**Piérand, Prof. E.** Principes d'électrotechnie. Roy. 8vo. Tome III. Pp. 330. 3<sup>e</sup> édition. (Paris: Libr. Dunod, 1922.) 26 francs.

**Planck, Prof. Dr. M.** Die Entstehung und bisherige Entwicklung der Quantentheorie. Nobelvortrag, gehalten vor der Kgl. Schwed. Akademie der Wissenschaften zu Stockholm am 2. Juni 1920. 2 unveränderter Abdruck. Pp. 32. (Leipzig: J. A. Barth, 1922.) 20 marks.

**Richards, C. R., and Vedder, J. N.** The Reheating of Compressed Air. (University of Illinois Engineering Experiment Station, Bulletin No. 130.) Med. 8vo. Pp. 95. (Urbana: University of Illinois; London: Chapman and Hall, Ltd., 1922.) 50 cents.\*

**Satterly, Dr. J.** Junior Heat. Second edition. Cr. 8vo. Pp. viii+188. (London: University Tutorial Press, Ltd., 1922.) 3s.

**Seiliger, M.** Graphische Thermodynamik und Berechnen der Verbrennungsmaschinen und Turbinen. Pp. viii+250. (Berlin: J. Springer, 1922.) 160 marks.

**Serralunga, E.** L'elettricità nelle miniere. 8vo. Pp. xvi+276. (Milano: Tamburini C. fu C., 1922.) 38 lire.

**Silberstein, Dr. L.** The Theory of General Relativity and Gravitation: Based on a Course of Lectures delivered at the Conference on Recent Advances in Physics held at the University of Toronto, in January, 1921. Demy 8vo. Pp. vi+141. (Toronto: University of Toronto Press, 1922.) 2.50 dollars.\*

**Sleeper, M. B.** Construction of Radio Phone and Telegraph Receivers for Beginners. Cr. 8vo. Pp. 142. (London: The Wireless Press, Ltd., 1922.) 4s. net.

**Sleeper, M. B.** How to make Commercial Type Radio Apparatus. Cr. 8vo. Pp. 160. (London: The Wireless Press, Ltd., 1922.) 4s. net.

**Sleeper, M. B.** The Radio Experimenter's Handbook. Fcap. 8vo. Pp. 143. (London: The Wireless Press, Ltd., 1922.) 5s. net.

**Stark, Prof. Dr. J.** Die elektrischen Quanten. 2 umgearbeitete Auflage. Large 8vo. Pp. vii+95. (Leipzig: S. Hirzel, 1922.) 55 marks.

**Stark, Prof. Dr. J.** Die gegenwärtige Krisis in der deutschen Physik. Pp. vi+32. (Leipzig: J. A. Barth, 1922.) 40 marks.

**Sticklers, J.** Die wahre Relativitätstheorie der Physik und die Missgriffe Einstein's. Large 8vo. Pp. iv+57. (Bielefeld: Dr. W. Breitenbach, 1922.) 20 marks.

**Thomälen, Prof. Dr. A.** Kurzes Lehrbuch der Elektrotechnik. 9 verbesserte Auflage. Large 8vo. Pp. viii+396. (Berlin: J. Springer, 1922.) 80 marks.

**Werth, F.** Galvanizzazione: Politura verniciatura metalli. 4 edizione rifatta a cura dell' J. Ghersi. Pp. xxiii+658. (Milano: U. Hoepli, 1922.) 26 lire.

**Wright, L.** The Microscope: A Practical Handbook. Enlarged and rewritten by Dr. A. H. Drew. Cr. 8vo. Pp. 287. (London: Religious Tract Society, 1922.) 5s. net.\*

**Yates, R. F., and Pacent, L. G.** The Complete Radio Book. Cr. 8vo. Pp. xiii+330. (London: Eveleigh Nash and Grayson, Ltd., 1922.) 7s. 6d. net.

**Young, A. P., and Warren, H.** Sparking Plugs: An Original Treatment of Theory and Practice for Students, Designers, and Users of Ignition Devices. (Pitman's Technical Primers.) Fcap. 8vo. Pp. xiii+106. (London: Sir I. Pitman and Sons, Ltd., 1922.) 2s. 6d. net.

## Chemistry

**Alamelle, Dr. E., et Flamand, F.** Cours de physique et de chimie. Conforme au programme du 18 août 1920. Écoles primaires supérieures. Cours complémentaires. Fcap. 8vo. (Paris: F. Alcan, 1922.) 7.50 francs.

**Arrhenius, S.** Die Chemie und das moderne Leben. Autorisierte deutsche Ausgabe von Dr. B. Finkelstein. Pp. 373. (Leipzig: Akademische Verlagsgesellschaft m. b. H., 1922.)

**Beilstein, F. K.** Handbuch der organischen Chemie. Herausgegeben von B. Prager und P. Jacobson. 4. Auflage. Band 4: Acyclische Sulfinsäuren und Sulfonsäuren, Acyclische Amine, Hydroxylamine, Hydrazine und weitere Verbindungen mit Stickstoff-Funktionen. Acyclische C-Phosphor, C-Arsen-, C-Antimon-, C-Wismut-, C-Silicium-Verbindungen und metallorganische Verbindungen. Large 8vo. Pp. xv+734. (Berlin: J. Springer, 1922.) 352 marks.

**Benrath, Prof. Dr. A.** Physikalische Chemie. Small 8vo. Pp. 88. (Heidelberg: W. Ehrig, 1922.) 10 marks.

**Bitterli, E.** Recherches sur le mécanisme de la formation d'acide sulfurique dans le procédé des chambres. 8vo. Pp. 58. (Paris: Gauthier-Villars et Cie, 1922.)

**Böhlmann.** Code chimique. En combinaison avec le livre d'adresses de l'Industrie allemande des produits chimiques. 8vo. (Paris: G. Ficker, 1922.) 100 francs.

**Boutot.** Étude du dosage de sucres réducteurs au moyen des liqueurs cuproalkalines. 8vo. (Paris: E. Le François, 1922.) 8 francs.

**Brandstätter, Prof. F.** Chemische Schulversuche. Large 8vo. Pp. 356. (Wien: A. Pichlers Witwe und Sohn, 1922.) 50 marks.

**Bruyants, Prof. P.** Traité élémentaire de chimie. Tome II: Chimie organique. 1<sup>re</sup> partie. Roy. 8vo. Pp. 484. (Paris: Gauthier-Villars et Cie, 1922.) 36 francs.

**Bull, P. G.** Chemistry of To-day: the Mysteries of Chemistry lucidly explained in a Popular and Interesting Manner free from all Technicalities and Formulae. Cr. 8vo. Pp. 311. (London: Seeley, Service, and Co., Ltd., 1922.) 8s. 6d. net.\*

**Cain, Dr. J. C.** The Manufacture of Dyes. Demy 8vo. Pp. ix+274. (London: Macmillan and Co., Ltd., 1922.) 12s. 6d. net.\*

**Chapin, Prof. W. H.** Second Year College Chemistry. Med. 8vo. Pp. 311. (New York: J. Wiley and Sons, Inc., 1922.) 3 dollars.

**Cumming, Dr. A. C., and Kay, Dr. S. A.** A Text-Book of Quantitative Chemical Analysis. Fourth edition. Demy 8vo. Pp. xv+432. (London: Gurney and Jackson; Edinburgh: Oliver and Boyd, 1922.) 15s. net.\*

**Davidson, Prof. A. W., and Klooster, Prof. H. S. van.** Laboratory Manual of Physical Chemistry. Med. 8vo. Pp. 182. (New York: J. Wiley and Sons, Inc., 1922.) 2 dollars.

**Department of Scientific and Industrial Research.** British Association for the Advancement of Science: Fourth Report on Colloid Chemistry and its General and Industrial Applications. Demy 8vo. Pp. 382. (London: H.M. Stationery Office, 1922.) 5s. 6d. net.\*

**Errera, G.** Trattato di chimica organica. Vol. II. 8vo. Pp. 384. (Palermo: Remo Sandron, 1922.) 24 lire.

**Fodor, Prof. Dr. A.** Das Fermentproblem. Large 8vo. Pp. ix+280. (Dresden und Leipzig: Th. Steinkopff, 1922.) 65 marks.

- Georgievics, Prof. Dr. G.** Handbuch der Farbenchemie. 5 erweiterte Auflage. Pp. vii + 504. (Leipzig und Wien: F. Deuticke, 1922.) 250 marks.
- Getman, Dr. F. H.** Outlines of Theoretical Chemistry. Third edition, thoroughly revised. Ex. Cr. 8vo. Pp. 615. (New York: J. Wiley and Sons, Inc., 1922.) 3.75 dollars.
- Giosia, A.** Chimica farmaceutica inorganica. 2 vols. 8vo. Vol. I: Chimica dei metalloidi. Pp. 242. 17.50 lire. Vol. II: Chimica dei metalli. Pp. 242. 35 lire. (Padua: La Litotipo, 1922.)
- Guieth, J.** Sur une méthode de préparation d'amines tertiaires diméthylés à l'azote. Pp. 31. (Paris: Gauthier-Villars et Cie, 1922.)
- Handovsky, Dr. H.** Leitfaden der Kolloidchemie für Biologen und Mediziner. Large 8vo. Pp. xvi + 206. (Dresden und Leipzig: Th. Steinkopff, 1922.) 45 marks.
- Hari, Prof. Dr. P.** Kurzes Lehrbuch der physiologischen Chemie. 2 verbesserte Auflage. Large 8vo. Pp. x + 353. (Berlin: J. Springer, 1922.) 90 marks.
- Henrich, Prof. Dr. F.** Theories of Organic Chemistry. Translated and enlarged from the revised Fourth German edition of 1921 by Prof. T. B. Johnson and Prof. Dorothy A. Hahn. Med. 8vo. Pp. xvi + 603. (New York: J. Wiley and Sons, Inc.; London: Chapman and Hall, Ltd., 1922.) 30s. net.\*
- Hoffmann, Prof. Dr. F.** Chemie. Umgearbeitet von R. M. Paradies. Selbst-Unterrichts-Briefe: Methode Rustin. 10 vollständig umgearbeitete Auflage. 4to. Pp. 29. (Potsdam und Leipzig: Bonness und Hachfeld, 1922.) 5.40 marks.
- Kirchhoff, Dr. J.** Wiederholungs-Tafel der anorganischen Chemie für die oberen Klassen aller höheren Lehranstalten (insbes. Abiturienten), Tentamen physicum usw. usw. Roy. 4to. Pp. 2. (Köln: Kirchhoff und Co., 1922.) 6 marks.
- Klein, Dr. J.** Chemie. Anorganischer Teil. (Sammlung Götschen 37.) 7 verbesserte Auflage. Small 8vo. Pp. 170. (Berlin und Leipzig: W. de Gruyter und Co., 1922.) 12 marks.
- Krause, H.** Chemisches Auskunftsbuch für Fabrikanten, Gewerbetreibende und Landwirte. (Chemisch-technische Bibliothek, Band 321.) 2 verbesserte Auflage. 8vo. Pp. vii + 254. (Wien und Leipzig: A. Hartleben, 1922.) 72 marks.
- Lefebure, V.** The Riddle of the Rhine: Chemical Strategy in Peace and War. Third impression. Cr. 8vo. Pp. 292. (London: W. Collins, Sons, and Co., Ltd., 1922.) 2s. 6d. net.
- Lespieau, R., et Colin, Ch.** Cours et expériences de chimie. Nouvelle édition refondue conforme aux programmes de 1920. 3<sup>e</sup> année. Fcap. 8vo. Pp. 211. (Paris: Hachette et Cie, 1922.) 7.50 francs.
- Luppo-Cramer, Dr.** Negativ-Entwicklung bei hellem Lichte. Safranverfahren. (Photographischer Bücherschatz, Band 18.) 2 neubearbeitete und erweiterte Auflage. Pp. 170. (Leipzig: E. Liesegang Verlag, 1922.)
- Michaelis, L.** Die Wasserstoffionen-Konzentration, ihre Bedeutung für die Biologie und die Methoden ihrer Messung. (Monographien aus dem Gesamtgebiet der Physiologie der Pflanzen und der Tiere, Band 1.) 2 völlig umgearbeitete Auflage. 8vo. Teil I: Die theoretischen Grundlagen. Pp. xi + 262. (Berlin: J. Springer, 1922.) 69 marks.
- Müller, Dr. K.** Reibschädlinge und ihre neuzeitliche Bekämpfung. Zweite umgearbeitete Auflage. (Karlsruhe i. B.: G. Braunsche, 1922.)
- Nielsen, K.** Organisk Kemi. 8vo. Pp. 54. (Kopenhagen: Frimodt, 1922.) 1.75 kr.
- Nuova Enciclopedia di chimica scientifica, tecnologica e industriale, con le applicazioni a tutte le industrie chimiche e manifatturiere ecc., fondata e diretta da I. Guareschi e ultimata sotto la direzione del Dr. F. Garelli.** Vol. VI, Parte 2, Com-Feni. 4to. Pp. xii + 796. (Turin: Unione Tipografico-Editrice Torinese, 1922.) 60 lire.
- Perkin, Prof. W. H., and Kipping, Prof. F. S.** Organic Chemistry. Entirely new edition. Part I. Gl. 8vo. Pp. xi + 681 + xx. (London and Edinburgh: W. and R. Chambers, Ltd.; Philadelphia: J. B. Lippincott Co., 1922.) 8s. 6d. net.\*
- Scheid, K.** Anorganische Chemie. 3 Auflage. 8vo. Pp. viii + 243. (Leipzig: Quelle und Meyer, 1922.) 28 marks.
- Shettler, R., and Eppler, A.** Lehrbuch der Chemie mit Einführung in die Mineralogie und Geologie für Realschulen, Lyzeen, höhere Mädchenschulen und verwandte Anstalten, neu bearbeitete von R. Shettler. Ausgabe B. 3 Auflage. 8vo. Pp. 309. (Leipzig: Quelle und Meyer, 1922.) 44 marks.
- Simmonds, C.** Alcohol in Commerce and Industry. (Pitman's Common Commodities and Industries.) Cr. 8vo. Pp. xii + 119. (London: Sir I. Pitman and Sons, Ltd., 1922.) 3s. net.\*
- Spencer, Prof. J. F.** Les Métaux des terres rares. Traduit, revu et augmenté par Dr. J. Daniel. Roy. 8vo. Pp. x + 280. (Paris: Libr. Dunod, 1922.) 36 francs.
- Spica, P.** Chimica bromatologica. 2 edizione riveduta et accresciuta. Pp. 204. (Padua: La Litotipo, 1922.) 30 lire.
- Torre, G. del.** Trattato di chimica generale. 6 edizione. 8vo. Pp. 812. (Milano: Società editrice Dante Alighieri, 1922.) 12 lire.
- Üllmann, Prof. Dr. F.** Encyclopädie der technischen Chemie. Band 11: Stickstoff-Wassersuperoxyd. 4to. Pp. iv + 684. (Berlin und Wien: Urban und Schwarzenberg, 1922.) 500 marks.
- Widerlich, Prof. R.** Lehrbuch der Chemie für höhere Lehranstalten. Teil I: Unterstufe. Large 8vo. Pp. vi + 144. (Braunschweig: F. Vieweg und Sohn, 1922.) 16 marks.
- Wolff, H.** Die Lösungsmittel der Fette, Öle, Wachs und Harze. (Monographien aus dem Gebiete der Fettchemie, Band 1.) Large 8vo. Pp. viii + 118. (Stuttgart: Wissenschaftliche Verlagsgesellschaft, 1922.) 75 marks.

## Technology

- Ahrons, E. L.** Lubricating of Locomotives. 8vo. Pp. 192. (London: Locomotive Publishing Co., Ltd., 1922.) 5s. net.
- Andes, L. E.** Papier-Spezialitäten. (Chemisch-technische Bibliothek, Band 223.) 2 vermehrte und verbesserte Auflage. 8vo. Pp. xvi + 334. (Wien und Leipzig: A. Hartleben, 1922.) 90 marks.
- Andes, L. E.** Die Fabrikation der Papiermaché- und Papierstoff-Waren. (Chemisch-technische Bibliothek, Band 239.) 2 vermehrte Auflage. 8vo. Pp. xv + 395. (Wien und Leipzig: A. Hartleben, 1922.) 72 marks.
- Andes, L. E.** Praktisches Handbuch für Anstreicher und Lackierer. (Chemisch-technische Bibliothek, Band 115.) 5 vollständig umgearbeitete Auflage. 8vo. Pp. viii + 287. (Wien und Leipzig: A. Hartleben, 1922.) 80 marks.
- Andes, L. E.** Feuersicher-, Geruchlos- und Wasserdichtmachen aller Materialien, die zu technischen und sonstigen Zwecken verwendet werden, mit einem Anhang: Die Fabrikation des Linoleums. (Chemisch-technische Bibliothek, Band 222.) 8vo. Pp. viii + 296. (Wien und Leipzig: A. Hartleben, 1922.) 96 marks.
- Andree, J.** Bergbau in der Vorzeit. 1: Bergbau auf Feuerstein, Kupfer, Zinn und Salz in Europa. Nebst einem Anhang: Bergmännische Gewinnung von Kalkspat, Ocker und Bergkristall. 4to. Pp. iv + 72. (Leipzig: C. Kabitzsch, 1922.) 60 marks.
- Andres, E.** Die Fabrikation der Lacke, Firnisse, Buchdrucker-Firnisse und des Siegelackes. (Chemisch-technische Bibliothek, Band 9.) 7 vermehrte und neubearbeitete Auflage von E. Stock. 8vo. Pp. viii + 280. (Wien und Leipzig: A. Hartleben, 1922.) 90 marks.
- Ascher, Dr. R.** Die Schmiermittel, ihre Art, Prüfung und Verwendung. Ein Leitfaden für den Betriebsmann. 8vo. Pp. viii + 247. (Berlin: J. Springer, 1922.) 69 marks.
- Bacon, Dr. R. F., and Hamor, W. A.** American Fuels. (Mellon Institute Technochemical Series.) Med. 8vo. Vol. 1, Pp. ix + 628. Vol. 2, Pp. vi + 629-1257. (New York and London: McGraw-Hill Book Co., Inc., 1922.) 60s.\*
- Bataille, E.,** avec la collaboration de Chaptl, A., et Thellesme, J. de. Pour le Peintre-vitrier: origine, composition et propriétés, des matières premières, recettes, formules, procédés, "trucs" et tours de main du praticien. Gl. 8vo. Pp. viii + 164. (Paris: Libr. Dunod, 1922.) 7 francs.



- Baumann, R.** Die bisherigen Ergebnisse der Holzprüfungen in der Materialprüfungsanstalt an der Technischen Hochschule Stuttgart. (Forschungsarbeiten auf der Gebiete des Ingenieurwesens, Heft 231.) 4to. Pp. 139+13 Tafeln. (Berlin: J. Springer, 1922.) 85 marks.
- Bersch, Dr. J.** Zellulose, Zelluloseprodukte und Kautschuksurrogate. (Chemisch-technische Bibliothek, Band 269.) 2 völk. umgearbeitete und verbesserte Auflage von P. E. Altmann. 8vo. Pp. viii+239. (Wien und Leipzig: A. Hartleben, 1922.) 72 marks.
- Bertrand, L., et Lanquaine, A.** Sur la composition et la structure microscopique des argiles, leur fusibilité et les transformations qu'elles subissent à haute température. 8vo. Pp. 15. (Paris: L. Eyrolles, 1922.)
- Bogue, Dr. R. H.** The Chemistry and Technology of Gelatin and Glue. (Mellon Institute Technochemical Series.) Med. 8vo. Pp. xi+644. (New York and London: McGraw-Hill Book Co., Inc., 1922.) 30s.\*
- Brauer-Tuchorze, J. E.** Moderne Hefefabrikation. Handbuch nebst einem Anhang über Backpulverbereitung. (Die Werkstatt, Band 54.) 6 vollständig neubearbeitete Auflage von H. Marquard's "Pfund- und Presshefe." Large 8vo. Pp. xvi+168. (Leipzig: B. F. Voigt, 1922.) 60 marks.
- Breuil, P.** Contribution à l'étude des colles et collages pour bois. 8vo. Pp. 86. (Paris: L. Eyrolles, 1922.)
- Bruns, H.** Der Eisenwirtschaftsbund. (Beiträge zur Lehre von den industriellen, Handels- und Verkehrsunternehmen, Heft 6.) Large 8vo. Pp. vi+94. (Jena: G. Fischer, 1922.) 36 marks.
- Ciocca, G.** Gelati, dolci freddi, rinfreschi, bibite refrigeranti, conserve e composte di frutta e l'arte di presentarli. 2 edizione rifatta. Fcap. 8vo. Pp. xxxii+252. (Milano: U. Hoepli, 1922.) 12.50 lire.
- Collette, A.** Les Projections cinématographiques d'enseignement. Gl. 8vo. Pp. 40. (Paris: Gauthier-Villars et Cie, 1922.) 2 francs.
- Conques, J. Le** Charbon. Origine de la houille. Création d'une mine. Matériel d'extraction. Rôle économique et social du charbon. Accidents de mines. (Collection Monde et Science.) (Paris: A. Lemerre, 1922.) 7 francs.
- Cremser, F.** Die Fabrikation der Silber- und Quecksilber-Spiegel oder das Belegen der Spiegel auf chemischem und mechanischem Wege. (Chemisch-technische Bibliothek, Band 154.) 8vo. Pp. viii+224. (Wien und Leipzig: A. Hartleben, 1922.) 60 marks.
- Durville, J. P.** Nouveau Formulaire des parfums et des cosmétiques (Parfums naturels et parfums synthétiques). 2<sup>e</sup> édition revue et augmentée. Pp. xiii+597. (Paris: Libr. Desforges, 1922.) 35 francs.
- Fahr, Dr. O.** Die Einführung von Zeitstudien in einem Betrieb für Reihen- und Massenfertigung der Metallindustrie. Large 8vo. Pp. viii+149+16. (München und Berlin: R. Oldenbourg, 1922.) 38 marks.
- Farquhar, Prof. H. H.** Factory Storekeeping: The Control and Storage of Material. Med. 8vo. Pp. xi+182. (New York and London: McGraw-Hill Book Co., Inc., 1922.) 12s. 6d.\*
- Favier et Aribert.** Machines pour la fabrication du papier. (Bibliothèque de l'ingénieur-mécanicien.) 8vo. Pp. 248. (Paris: A. Michel, 1922.) 20 francs.
- Fraenkel, W.** Leitfaden der Metallurgie mit besonderer Berücksichtigung der physikalisch-chemischen Grundlagen. Pp. viii+223. (Dresden und Leipzig: T. Steinkopff, 1922.) 45 marks.
- Ganswindt, Dr. A.** Die Bastfasern und ihre technische Verarbeitung. Pp. 516. (Wien und Leipzig: A. Hartleben, 1922.) 180 marks.
- Ganswindt, A.** Die Riechstoffe. 8 völlig neubearbeitete Auflage von A. Mierzinski. 4to. Pp. xvi+362. (Leipzig: B. F. Voigt, 1922.) 150 marks.
- Gibson, C. R.** The Romance of Coal: A Popular Account of the Origin and Nature of Coal, the Forces and Qualities, Destructive or Beneficial, which lie latent in it, and the great variety of Uses to which they may be turned in Science, Art and Industry. (The Library of Romance.) Cr. 8vo. Pp. 310. (London: Seeley, Service, and Co., Ltd., 1923.) 6s. net.
- Gould, G. B.** Judging Coal Values: The Practical Problem of Selecting and Buying Eastern Coals. 8vo. Pp. 52. (New York: Fuel Engineering Co., 1922.) 3 dollars.
- Granjon, R., et Rosemberg, P.** Manuel pratique de soudure autogène. 8vo. Pp. vi+400. (Paris: Libr. Dunod, 1922.) 13 francs.
- Grasser, Dr. G.** Handbuch für gewerbereicherische Laboratorien. 2 vermehrte und verbesserte Auflage. Large 8vo. Pp. xiv+472. (Leipzig: P. Schulze, 1922.) 150 marks.
- Hammond, S. E. E.** Pasteless Paper Construction. 8vo. Pp. 47. (Milwaukee, Wis.: Bruce Publishing Co., 1922.) 0.60 dollars.
- Hendricks, J.** Notes spéciales sur la fabrication du ciment Portland artificiel. 8vo. Pp. 160. (Paris: Libr. Calmann-Lévy, 1922.) 7 francs net.
- Irresberger, G.** Kupolofenbetrieb. (Werkstattbücher für Betriebsbeamte, Vor- und Facharbeiter, Heft 10.) Large 8vo. Pp. 54. (Berlin: J. Springer, 1922.) 9 marks.
- Keppeler, G.** Die Brennstoffe und ihre Verbrennung. Large 8vo. Pp. iv+60. (Berlin: R. Oldenbourg, 1922.) 40 marks.
- Klamer, Th. H.** Het kleuren van metalen. Een beknopte handboekje voor metaalbewerkers en voor allen, die in de versieringstechniek van metalen werkzaam zijn. Pp. v+iv+138. (Deventer: Ae. E. Kluwer, 1922.) 2.50 fl.
- Knecht, E., and others.** A Manual of Dyeing. Seventh edition. In 2 vols. Med. 8vo. Pp. 383; 528. (London: C. Griffin and Co., Ltd., 1922.) 42s. net.
- Krämer, W.** Bandwalzwerke: Weissblech-Weissband. 4to. Pp. 33. (Bochum: G. Wilberg, 1922.)
- Krupp, A.** Die Legierungen. Handbuch für Praktiker. (Chemisch-technische Bibliothek, Band 52.) 4 erweiterte vermehrte und vollständig umgearbeitete Auflage. 8vo. Pp. viii+501. (Wien und Leipzig: A. Hartleben, 1922.) 120 marks.
- Lebrun, M.** Soudure et découpage des métaux par l'arc électrique. 8vo. Pp. 43. (Paris: Gauthier-Villars et Cie, 1922.) 3.50 francs.
- Ledebur, A.** Leitfaden für Eisenhütten-Laboratorien. 11 Auflage neu bearbeitet von H. Kinder und A. Stadler. Large 8vo. Pp. x+182. (Braunschweig: F. Vieweg und Sohn, 1922.) 21 marks.
- Loescher, F.** Vergrössern und Kopieren auf Bromsilber- und Gaslichtpapieren. (Photograph. Bibliothek, Band 15.) 5 Auflage neu bearbeitete und erweiterte von K. Weiss. 8vo. Pp. vi+106. (Berlin: Union, Zweigniederlassung, 1922.) 40 marks.
- Lombard, J.** Manuel de l'ouvrier tourneur et fileteur. 4<sup>e</sup> édition. Ex. Cr. 8vo. Pp. iv+232. (Paris: Libr. Dunod, 1922.) 9 francs.
- Luhmann, Dr. E.** Die Fabrikation der moussierenden Getränke. (Chemisch-technische Bibliothek, Band 84.) 5 neu bearbeitete und erweiterte Auflage des in 1 Auflage von O. Meitz verf. Werkes. 8vo. Pp. xiii+256. (Wien und Leipzig: A. Hartleben, 1922.) 48 marks.
- Lunge, G., und Berl, E.** Chemisch-technische Untersuchungsmethoden. Herausgegeben von E. Berl. Band 2. 7 vollständig umgearbeitete und vermehrte Auflage. Large 8vo. Pp. xlv+1411. (Berlin: J. Springer, 1922.) 600 marks.
- Marsh, C. F., and Dunn, W.** A Manual of Reinforced Concrete. Fourth edition, improved and enlarged. Fcap. 8vo. Pp. xvi+504. (London: Constable and Co., Ltd., 1922.) 21s. net.
- Menzel, J.** Automobilvergaser. (Autotechnische Bibliothek, Band 10.) 5 Auflage von A. König. Small 8vo. Pp. 330. (Berlin: R. C. Schmidt and Co., 1922.) 40 marks.
- Merritt, H. E., and Platt, M.** A Text Book of Machine Construction and Drawing. Fcap. 4to. Pp. x+197. (London: G. Bell and Sons, Ltd., 1922.) 7s. 6d. net.\*
- Michel, F.** Edelmetall-Probierkunde. 8vo. Pp. 77. (Pforzheim: C. W. Drais, 1922.) 75 marks.
- Naumann, E.** Södra od mellersta Sveriges sjö-och myrsmalmer, deras bildnings-historia, utbredning och praktiska betydelse. (Sveriges geologiska undersökning, Ser. C: Avhandlingar och uppsatser, aarsbok 13, nr. 6.) 8vo. Pp. iv+194. (Stockholm: Lars Hökerberg, 1922.) 2 kr.

**Oertens, R.** La zucca vernina nella sua più dolce trasformazione commestibile: La marmellata. 8vo. Pp. 64. (Catania: F. Battiato, 1922.) 4 lire.

**Petzholdt, H.** Kakao und Schokolade. Eine Übersichtstafel über die Herstellungsvorgänge. Large 8vo. (Dresden: A. Dressel, 1922.) 24 marks.

**Pfeiffer, K.** Über Erdöl, Bitumen, Ölschiefer und künstliche Schmieröle. Als Festschrift zum 80 Geburtstag C. Engler's im Zusammenhang dargest. 4to. Pp. ix+100. (Leipzig: S. Hirzel, 1922.) 50 marks.

**Pile, S., and Johnston, R.** Tested Methods of Metallurgical Analysis (Non-Ferrous). Gl. 8vo. Pp. 128. (London: H. F. and G. Witherby, 1922.) 7s. 6d. net.\*

**Ponte, M. da.** Distillazione. (Vino—Vino—Frutta fermentate—Amidacei—Erbe aromatiche—Fiori, ecc.—Estrazione del cremore di tartaro, dell'olio dai vinaccioli, dei succhi dolci fermentiscibili, ecc.—Sterilizzazione del succo d'uva, fabbricazione dei vini spumanti—Preparazione dell'acquazente, delle bibite alcoliche ed analcoliche.) 4 edizione interamente rifatta. Fcap. 8vo. Pp. xxx+847. (Milano: U. Hoepli, 1922.) 37.50 lire.

**Püringer, R.** Das Eisen. Seine Herkunft und Gewinnung. (Deutsche Hausbücherei, Band 21.) 8vo. Pp. 74. (Wien: Schulbuchverlag, 1922.) 280 kr.

**Reichenheim, P.** Die wirtschaftliche Bedeutung der flüssigen Treibstoffe. 8vo. Pp. iv+85. (Berlin: J. Springer, 1922.) 20 marks.

**Riedl, J.** Die Warmewirtschaft des Hausbrandes im Unterricht unserer Schulen. 4to. Pp. 100. (München: J. A. Mahr, 1922.) 60 marks.

**Rossi, A.** Il profumiere. 3 edizione. Pott 8vo. Pp. xii+605. (Milano: U. Hoepli, 1922.) 26 lire.

**Rottmann, W.** Einführung in den Bau von Gebläsen. 13 Auflage. Large 8vo. Pp. 24. (Potsdam und Leipzig: Bonness und Hächfeld, 1922.) 12 marks.

**Schlosser, E.** Das Löten und Schweißen. (Chemisch-technische Bibliothek, Band 73.) 5 neubearbeitete Auflage. 8vo. Pp. vii+257. (Wien und Leipzig: A. Hartleben, 1922.) 72 marks.

**Schonebaum, C. W.** Ozonisieren van fabrieksproducten der suikerindustrie. 8vo. Pp. v+87. (Amsterdam: A. H. Kruyt, 1922.) 3.50 fl.

**Schonebaum, C. W.** Methoden van berekening in de suikerfabriek. 8vo. Pp. vii+48. (Amsterdam: A. H. Kruyt, 1922.) 2.25 fl.

**Schwalbe, Prof. Dr. C. G., and Sieber, Dr. R.** Die chemische Betriebskontrolle in der Zellstoff- und Papierindustrie und anderen Zellstoff verarbeitenden Industrien. Large 8vo. 2 umgearbeitete und vermehrte Auflage. Pp. xiv+374. (Berlin: J. Springer, 1922.) 337.50 marks.

**Stark, Prof. Dr. J.** Die physikalisch-technische Untersuchung keramischer Kaoline. Pp. vi+145. (Leipzig: J. A. Barth, 1922.) 160 marks.

**Tarié, A. de.** La Préparation industrielle de la guerre en France et en Allemagne: La Métallurgie. 8vo. Pp. iv+56. (Paris: Libr. Chapelot, 1922.)

**Tranchina, D. Carollo.** Manualeetto di oleificio: Guida pratica per l'estrazione, manifattura e conservazione dell'olio d'oliva. (Monografie agrarie e zootecniche, n. 62.) 2 edizione. (Catania: F. Battiato, 1922.) 2.50 lire.

**Vita, A., and Massenze, C.** Chemische Untersuchungsmethoden für Eisenhütten und Nebenbetriebe. 2 neubearbeitete Auflage von A. Vita. 8vo. Pp. x+197. (Berlin: J. Springer, 1922.) 78 marks.

**Walter, E.** Die moderne Fruchtsaftindustrie und verwandte Zweige der Obstverwertung (Obstweine, Obstschäume und Obstbrennerei.) 2 Auflage. 8vo. Pp. 148. (Leipzig: O. Born, 1922.) 90 marks.

**Walter, E.** Moderne Destillierkunst. Ein Rezeptbuch für die Destillations-Branche. 6 Auflage. 8vo. Pp. 157. (Leipzig: O. Born, 1922.) 50 marks.

**Zeidler, H.** Die moderne Lederfabrikation. (Die Werkstatt, Band 16.) 2 Auflage von A. Matthies. Large 8vo. Pp. xii+205. (Leipzig: B. F. Voigt, 1922.) 75 marks.

### Astronomy

**Graff, K.** Astrophysik. Dritte völlig neubearbeitete Auflage von J. Scheiners "Populäre Astrophysik." Pp. viii+459+17 Tafeln. (Leipzig: B. G. Teubner, 1922.) 125 marks.

**Jones, H. S.** General Astronomy. Demy 8vo. Pp. viii+392+24 plates. (London: E. Arnold and Co., 1922.) 21s. net.\*

**Maillard, Prof. L.** Cosmogonie et gravitation. 2 Mémoires. 8vo. Pp. 40. (Paris: Gauthier-Villars et Cie, 1922.) 3 francs.

**Montméner, L.-P. de.** Nouvelle théorie sur l'évolution de la Terre et des Mondes compréhensible pour tous. 8vo. Pp. 142. (Paris: Libr. Perlican, 1922.)

**Proctor, Mary.** Legends of the Stars. Gl. 8vo. Pp. 128. (London: G. G. Harrap and Co., Ltd., 1922.) 1s.

### Meteorology

**Durward, Capt. J.** Diurnal Variation of Temperature as affected by Wind Velocity and Cloudiness: a Discussion of Observations on the Eiffel Tower. (Air Ministry: Meteorological Office. Professional Notes, No. 30.) (M.O. 245.) Med. 8vo. Pp. 83-91. (London: H.M. Stationery Office, 1922.) 4d. net.\*

**Johnson, N. K., and Sen, S. N.** A Comparison of the Anemometer Records for Shoeburyness and the Maplin Lighthouse. (Air Ministry: Meteorological Office. Professional Notes, No. 28.) (M.O. 245h.) Med. 8vo. Pp. 70-76. (London: H.M. Stationery Office, 1922.) 6d. net.\*

**Newnam, Mrs. E. V.** Hurricanes and Tropical Revolving Storms: A Memoir prepared in the Meteorological Office. With an Introduction on the Birth and Death of Cyclones: a Lecture given at a Conference of Meteorologists at Bergen on July 22, 1920, by Sir Napier Shaw. (Air Ministry: Meteorological Office. Geophysical Memoirs, No. 19.) (M.O. 220i.) Roy. 4to. Pp. viii+213-333+33 plates. (London: H.M. Stationery Office, 1922.) 12s. 6d. net.\*

**Zealley, P. R.** An Introduction to Forecasting Weather. Gl. 8vo. Pp. 32. (Cambridge: W. Heffer and Sons, Ltd.; London: Simpkin, Marshall, and Co., Ltd., 1922.) 1s. net.\*

### Mineralogy

**Barker, T. V.** Graphical and Tabular Methods in Crystallography as the Foundation of a New System of Practice: With a Multiple Tangent Table and a 5-figure Table of Natural Cotangents. Roy. 8vo. Pp. xvi+152. (London: T. Murby and Co., 1922.) 14s. net.\*

**Bellini, R., Segalini, L., and Carnevale, P.** Corso elementare di scienze fisiche e naturali, per gli istituti tecnici. Mineralogia, di R. Bellini. Fcap. 8vo. Pp. 188. (Turin: G. B. Paravia e C., 1922.) 10 lire.

**Brauns, Prof. Dr. R.** Die Mineralien der niederrheinischen Vulkangebiete. 4to. Pp. vii+225+40 Tafeln. (Stuttgart: E. Schweizerbart, 1922.) 400 marks.

**Carnot, A.** Traité d'analyse des substances minérales. Tome quatrième: Métaux (deuxième partie). Révisé et augmenté d'un appendice par E. Goutal. Roy. 8vo. Pp. 1050. (Paris: Libr. Dunod, 1922.) 65 francs.

**Carucci, P.** Fisica, chimica e mineralogia. 6 edizione. Fcap. 8vo. Pp. 320. (Napoli: G. Casella, 1922.) 10 lire.

**Fischer, F., and Schrader, H.** Entstehung und chemische Struktur der Kohle. 2 durch neue Ergebnisse Auflage. 8vo. Pp. 63. (Essen: W. Girardet, 1922.) 22 marks.

**Hoffmann, Prof. Dr. F.** Mineralogie. Selbst-Unterrichts-Briefe. Methode Rustin. 7 Auflage. 4to. Pp. 32. (Potsdam und Leipzig: Bonness und Hächfeld, 1922.) 5-40 marks.

**Moschen, L.** Nozioni di mineralogia e geologia, ad uso del liceo. Parte I: Mineralogia. 6 edizione. Pott 8vo. Pp. 188. (Milano: Società Editrice Dante Alighieri, 1922.) 5 lire.

**Olivier, Et.** Le Dosage des petites quantités de fluor particulièrement dans les blendes et autres minerais. 8vo. Pp. 27. (Paris: Libr. Calmann-Lévy, 1922.) 4 francs net.

### Geology

**Andrews, E. C.** The Geology of the Broken Hill District. (Memoirs of the Geological Survey of New South Wales: Geology, No. 8.) Med. 4to. Pp. xix+432+124 plates. (Sydney: Department of Mines, 1922.) 42s.\*

**Behme, Dr. F.** Geologischer Harzführer. 8vo. Teil 3: Das Okertal. 4 vollständig neubearbeitete Auflage. Pp. 64. 6 marks. Teil 4: Die jüngeren Gebirgsschichten in der Umgebung von Goslar am Harz. 4. Auflage. Pp. 64. 10 marks. (Hannover: Hahn'sche Buchhandlung, 1922.)

**Bosworth, Dr. T. O.** Geology of the Tertiary and Quaternary Periods in the North-West Part of Peru. With an Account of the Palaeontology, by H. Woods, Dr. T. W. Vaughan, Dr. J. A. Cushman, and others. Demy 8vo. Pp. xxii + 434. (London: Macmillan and Co., Ltd., 1922.) 45s. net.\*

**Dalloni, M.** La Géologie du pétrole et la recherche des gisements pétrolières en Algérie. 8vo. Pp. 340. (Alger: J. Carbonel, 1922.) 12 francs.

**Graf, G. E.** Entwicklungs-Geschichte der Erde. 2 verbesserte und erweiterte Auflage. 8vo. Pp. 111. (Berlin: Verlagsgenossenschaft Freiheit, 1922.) 24 marks.

**Haase, E.** Die Erdkrinde. Einführung in die Geologie. 4 verbesserte und vermehrte Auflage. 8vo. Pp. viii + 240. (Leipzig: Quelle und Meyer, 1922.) 42 marks.

**Handel, J. A.** Recherche et exploitation du pétrole. Large 8vo. Pp. 275. (Paris: Libr. Dunod, 1922.) 16 francs.

**Heritsch, F.** Geologie von Steiermark. 2. Auflage. Large 8vo. Pp. 224. (Graz: U. Moser, 1922.) 60 marks.

**Landenberger, E.** Die Geologie von Niederländisch-Indien nebst einem kurzen Anhang: Die Geologie der Philippinen. Ein Handbuch. Large 8vo. Pp. 216. (Stuttgart: E. Schweizerbart, 1922.) 150 marks.

**Milner, H. B.** An Introduction to Sedimentary Petrography: With special reference to Loose Detrital Deposits and their Correlation by Petrographic Methods. Cr. 8vo. Pp. 125. (London: T. Murby and Co., 1922.) 8s. 6d. net.\*

**Padey, B.** Les Secrets de la baguette et l'art du sourcier: Étude théorique et pratique. 8vo. Pp. 326. (Paris: C. Amat, 1922.)

**Royal Engineers.** The Work of the Royal Engineers in the European War, 1914-1919. Work in the Field under the Engineer-in-Chief, B.E.F. Geological Work at the Western Front. Roy. 8vo. Pp. 71 + 7 plates + 19 figs. (Chatham: W. and J. Mackay and Co., Ltd., 1922.)\*

**Royal Engineers.** The Work of the Royal Engineers in the European War, 1914-1919. Work in the Field in Other Theatres of War. Egypt and Palestine—Water Supply. Roy. 8vo. Pp. vi + 64 + 7 maps + 10 plates. (Chatham: W. and J. Mackay and Co., Ltd., 1921.)\*

**Thoms, G.** Einführung in die Geologie Nordwestdeutschlands. 8vo. Pp. 72. (Stuttgart: F. Enke, 1922.) 30 marks.

**Wagner, P.** Lehrbuch der Geologie und Mineralogie für höhere Schulen. 7 verbesserte Auflage. Large 8vo. Pp. viii + 176. (Leipzig und Berlin: B. G. Teubner, 1922.) 50 marks.

**Wilson, G. V.** The Ayrshire Bauxitic Clay. (Memoirs of the Geological Survey: Scotland.) Med. 8vo. Pp. vi + 28. (Southampton: Ordnance Survey Office; London: E. Stanford, Ltd., 1922.) 1s. 6d. net.\*

**Woodward, H. B.** The Geology of the London District. (Being the Area included in the Four Sheets of the Special Map of London.) Second edition, revised, by C. E. N. Bromehead; with Notes on the Palaeontology, by C. P. Chatwin. (Memoirs of the Geological Survey: England and Wales.) Med. 8vo. Pp. vi + 99. (Southampton: Ordnance Survey Office; London: E. Stanford, Ltd., 1922.) 1s. 6d. net.\*

## Geography: Travel

**Allen, Nellie B.** North America. (Geographical and Industrial Studies.) Gl. 8vo. Pp. xiv + 391. (Boston and London: Ginn and Co., 1922.) 4s. 6d. net.

**Allen, P. S.** Stewart's Handbook of the Pacific Islands: A Reliable Guide to all the Inhabited Islands of the Pacific Ocean for Traders, Tourists, and Settlers. With a Bibliography of Island Works. Demy 8vo. Pp. xxx + 566. (Australia: McCarron, Stewart, and Co.; London: Sifton, Praed, and Co., 1922.) 6s. 6d. net.

**Barker, W. H., and Brooks, L.** Junior Regional Geographies. Book I: The Peoples of the World. Cr. 8vo. Pp. 112. (London: University of London Press, Ltd., 1922.) 1s. 9d. net.

**Baud-Bovy, D., and Boissonnas, F.** In Greece: Journeys by Mountain and Valley. Translated from the French by C. F. Hardy. Imp. 4to. Pp. 132 + 40 plates. (H. W. Lewis, 40 Briarwood Road, S.W., 1922.) 42 net.

**Blache, P. Vidal de la.** Principes de géographie humaine. Publiés d'après les manuscrits de l'auteur par Emmanuel de Martonne. 8vo. Pp. viii + 328. (Paris: A. Colin, 1922.) 25 francs.

**Brandt, Dr. B.** Kulturgeographie von Brasilien. Med. 8vo. Pp. vi + 112 + 5 Tafeln. (Stuttgart: J. Engelhorns Nachf., 1922.) 6s.\*

**Dauzat, A.** La Géographie linguistique. (Bibliothèque de Culture générale.) Gl. 8vo. Pp. 200. (Paris: E. Flammarion, 1922.)

**Engeln, Prof. O. D. von.** Inheriting the Earth: or the Geographical Factor in National Development. Ex. Cr. 8vo. Pp. xvi + 379. (New York: The Macmillan Co.; London: Macmillan and Co., Ltd., 1922.) 9s. net.

**Erskine, Mrs. S.** Madrid: Past and Present. Cr. 8vo. Pp. 209. (London: J. Lane, 1922.) 7s. 6d. net.

**Forster, H. L.** The Adventures of a Tropical Travel. Demy 8vo. Pp. 359. (London: J. Lane, 1922.) 12s. 6d. net.

**Geddie, J.** The Scott Country. Painted by E. W. Haslehurst. Pp. 67 + 12 coloured plates. (London and Glasgow: Blackie and Son, Ltd., 1922.) 3s. net.

**Genep, A. van.** Traité comparatif des nationalités. Tome 1: Les éléments extérieurs de la nationalité. 8vo. Pp. xiv + 228. (Paris: Payot et Cie, 1922.)

**Guise, A. V. L.** Six Years in Bolivia: The Adventures of a Mining Engineer. Med. 8vo. Pp. 246. (London: T. Fisher Unwin, 1922.) 21s. net.

**Johnson, M.** Cannibal-land: Adventures with a Camera in the New Hebrides. Demy 8vo. Pp. viii + 191. (London: Constable and Co., Ltd., 1922.) 12s. 6d. net.

**Krebs, Prof. Dr. N.** Beiträge zur Geographie Serbiens und Rasciens. Med. 8vo. Pp. iv + 226 + 16 Tafeln. (Stuttgart: J. Engelhorns Nachf., 1922.) 12s.\*

**Laws, A. R., and Lance, P. A.** A Geography of the British Isles. Gl. 8vo. Pp. 320. (Oxford: Clarendon Press; London: Oxford University Press, 1922.) 3s. 6d.\*

**Leutenegger, Dr. A.** Begriff, Stellung und Einteilung der Geographie. Med. 8vo. Pp. v + 157. (Gotha: J. Perthes, 1922.) 3 goldmarks.\*

**MacBride, M.** Wild Lakeland. Painted by A. H. Cooper. 8vo. Pp. 237. (London: A. and C. Black, Ltd., 1922.) 7s. 6d. net.

**Megglé, A.** Le Domaine colonial de la France. Ses ressources et ses besoins. Guide pratique de l'Algérie, des Colonies, des pays de protectorat et territoires à mandat. (Bibliothèque d'histoire contemporaine.) Fcap. 8vo. Pp. viii + 344. (Paris: F. Alcan, 1922.)

**Moncrieff, A. R. H.** Surrey. Painted by S. Palmer. 8vo. Pp. 264. (London: A. and C. Black, Ltd., 1922.) 7s. 6d. net.

**Philly, H. St. J. B.** The Heart of Arabia: A Record of Travel and Exploration. In 2 vols. Demy 8vo. Vol. 1. Pp. xxiii + 386 + plates. Vol. 2. Pp. vii + 354 + plates. (London, Bombay, and Sydney: Constable and Co., Ltd., 1922.) 2 vols., 63s. net.\*

**Pickles, H.** The World and its Workers. (Elementary Commercial Geography.) Gl. 8vo. Pp. 293. (London: Oxford University Press, 1922.) 2s. 6d. net.

**Proders, C. H.** Adventures in Bolivia. Med. 8vo. Pp. xvi + 232. (London: J. Lane, 1922.) 12s. 6d. net.

**Resta, R.** L'educazione del geografo. (Biblioteca Pedagogica Antica e Moderna Italia e Straniera, vol. 42.) 8vo. Pp. iv + 412. (Milano: Società editrice Dante Alighieri di Albighi, Segati e C., 1922.)

**Rutter, O.** British North Borneo: an Account of its History, Resources, and Native Tribes. Demy 8vo. Pp. xvi + 404 + plates. (London, Bombay, and Sydney: Constable and Co., Ltd., 1922.) 21s. net.\*

**Vallerey, J.** Physique du globe. 5<sup>e</sup> édition. 8vo. Pp. iv + 174. (Paris: A. Challamel, 1922.)

**Winter, J. B.** From Switzerland to the Mediterranean on Foot. Cr. 8vo. Pp. 124. (London: T. Werner Laurie, Ltd., 1922.) 5s. net.

### Palaeontology

**Naef, A.** Die fossilen Tintenfische, eine paläozoologische Monographie. *Med. 8vo.* Pp. vi+322. (Jena: G. Fischer, 1922.) 100 marks.

### General Biology: Natural History

**Abderhalden, Prof. Dr. E.,** Herausgegeben von. Handbuch der biologischen Arbeitsmethoden. Abt. V: Methoden zum Studium der Funktionen der einzelnen Organe des tierischen Organismus. Teil 3A, Heft 3, Lieferung 69: Entwicklungsmechanik. *Sup. Roy. 8vo.* Pp. 441-538. (Berlin und Wien: Urban und Schwarzenberg, 1922.) 630 marks.\*

**Batten, H. M.** Romances of the Wild. *Cr. 4to.* Pp. 156. (London and Glasgow: Blackie and Son, Ltd., 1922.) 10s. 6d. net.

**Bull, G.** Realms of Green. *Cr. 8vo.* Pp. viii+260. (London: Simpkin, Marshall, and Co., Ltd., 1922.) 6s. net.\*

**Coburn, C. A.** Heredity of Wildness and Savageneity in Mice. (Behavior Monographs. Vol. 4, No. 5, Serial No. 21.) *Sup. Roy. 8vo.* Pp. iv+71. (Baltimore, Md.: Williams and Wilkins Co., 1922.) 1 dollar.\*

**Fabre, J. H.** More Beetles. Translated by A. Teixeira de Mattos. *Cr. 8vo.* Pp. viii+322. (London: Hodder and Stoughton, Ltd., 1922.) 8s. 6d. net.\*

**Fabre, J. H.** The Life of the Woevel. Translated by A. Teixeira de Mattos. *Cr. 8vo.* Pp. viii+278. (London: Hodder and Stoughton, Ltd., 1922.) 8s. 6d. net.\*

**Moon, T. J.** Zoology for Beginners. *Cr. 8vo.* Pp. 568. (London: G. G. Harrap and Co., Ltd., 1922.) 6s.

**Terhune, A. P.** His Dog. *Cr. 8vo.* Pp. vii+186. (London and Toronto: J. M. Dent and Sons, Ltd., 1922.) 4s. 6d. net.\*

**Tregarthen, J. C.** Wild Life at the Land's End: Observations of the Habits and Haunts of the Fox, Badger, Otter, Seal, Hare, and of their Pursuers in Cornwall. Cheaper edition. *Ex. Cr. 8vo.* Pp. xii+236+204 plates. (London: J. Murray, 1922.) 7s. 6d. net.\*

**Tschulok, S.** Deszendenzlehre (Entwicklungslehre). Ein Lehrbuch auf historisch-kritischer Grundlage. Pp. xii+324. (Jena: G. Fischer, 1922.) 48 marks.

**Witherby, H. F.,** Edited by. A Practical Handbook of British Birds. (In 18 parts.) Parts 14-15. *Demy 8vo.* Pp. 449-624. (London: H. F. and G. Witherby, 1922.) 4s. 6d. net.\*

### Botany: Horticulture: Forestry

**Altson, A. M.** Beetles Damaging Seasoned Timber: With an account of their Ravages and the Method of Treatment. *Roy. 8vo.* Pp. 24. (London: Wm. Rider and Sons, Ltd., 1922.) 2s. 6d. net.

**Blatter, Prof. E.,** and **d'Almeida, Prof. J. F.** The Ferns of Bombay. *Cr. 8vo.* Pp. viii+228. (Bombay: D. B. Taraporevala, Sons, and Co., 1922.) 7.8 rupees.

**Bub-Bodmar, F.,** and **Tilger, B.** Die Konservierung des Holzes in Theorie und Praxis: Ein Handbuch. *Large 8vo.* Pp. xx+1066. (Berlin: P. Parey, 1922.) 680 marks.

**Czapek, F.** Biochemie der Pflanzen. (3 Bände.) Band I. 3 unveränderte Auflage. Pp. xix+828. (Jena: G. Fischer, 1922.) 270 marks.

**Davidson, H. C.** The Culture of Pot Plants: In Rooms, Greenhouses, and Frames. (Lockwood's Garden Manuals.) *Cr. 8vo.* Pp. vii+154. (London: C. Lockwood and Son, 1922.) 5s. net.

**Fletcher, F. J.** Market Nursery Work: A Series of Six Books on the Cultivation of Crops for Market. Vol. 6: Decorative Plants, Trees and Shrubs. *Demy 8vo.* Pp. vi+68. (London: Benn Brothers, Ltd., 1922.) 4s. 6d. net.\*

**Haas, Dr. P.,** and **Hill, T. G.** An Introduction to the Chemistry of Plant Products. Vol. 2: Metabolic Processes. *Demy 8vo.* Pp. viii+140. (London: Longmans, Green, and Co., 1922.) 7s. 6d. net.\*

**Maiden, J. H.** A Critical Revision of the Genus *Eucalyptus*. *Med. 4to.* Index to Vol. 5, Parts 41-50 (1920-1921). Pp. xi. Vol. 6, Part 4. (Part 5 of the Complete Work.) Pp. iv+165-218+plates 220-223. Vol. 6, Part 5. (Part 55 of the Complete Work.) Pp. iii+219-254+plates 224-227. (Sydney: J. Spence, 1922.) 3s. 6d. each.\*

**Roussopoulos, N. B.** Sur une réaction microchimique des membranes lignifiées. La réaction de Mäule. *8vo.* Pp. 20. (Lons-le-Saunier: L. Declume, 1922.)

**Thompson, Prof. J. M'L.** Studies in Floral Morphology. III: The Flowering of *Napoleona Imperialis*, Beauv. (Transactions of the Royal Society of Edinburgh. Vol. 53, Part 1, No. 13.) *Med. 4to.* Pp. 265-275. (Edinburgh: R. Grant and Son; London: Williams and Norgate, 1922.) 2s. 6d.\*

**Wagner, M.** Der chemische Betrieb in der Pflanze. (Biologische Arbeit, Heft 16.) *Large 8vo.* Pp. 64. Freiburg i. Br.: Th. Fisher, 1922.) 12 marks.

**Wrangell, M. von.** Gesetzmäßigkeiten bei der Phosphorsäure-ernährung der Pflanze. *4to.* Pp. iii+78. (Berlin: P. Parey, 1922.) 25 marks.

### Zoology

**Abderhalden, Prof. Dr. E.,** Herausgegeben von. Handbuch der biologischen Arbeitsmethoden. Abt. IX: Methoden zur Erforschung der Leistung der tierischen Organismus. Teil 1, Heft 2, Lieferung 71: Allgemeine Methoden. Zoologische allgemeine Methoden. *Sup. Roy. 8vo.* Pp. 97-438. (Berlin und Wien: Urban und Schwarzenberg, 1922.) 2160 marks.\*

**Austen, Major E. E.,** and **Heigh, E.** Tsetse-Flies: Their Characteristics, Distribution, and Bionomics, with some Account of Possible Methods for their Control. *Med. 8vo.* Pp. ix+188+5 plates. (London: Imperial Bureau of Entomology, 1922.) 7s. 6d. net.\*

**Bonnier, G.** Technologie. Zoologie appliquée. Pp. 256. (Paris: Les fils d'Émile Deyrolle, 1922.) 6 francs.

**Cushman, J. A.** The Foraminifera of the Atlantic Ocean. Part 3: Textulariidae. (Smithsonian Institution. U.S. National Museum: Bulletin 104.) *Med. 8vo.* Pp. viii+149+26 plates. (Washington: Government Printing Office, 1922.)\*

**Friese, Prof. Dr. H.,** Bearbeitet von. Die europäischen Bienen (Apidae). Das Leben und Wirken unserer Blumenwespen. Eine Darstellung der Lebensweise unserer wilden wie gesellig lebenden Bienen nach eigenen Untersuchungen für Naturfreunde, Lehrer und Zoologen. 1 Lieferung. *Roy. 8vo.* Pp. 112+7 Tafeln. (Berlin und Leipzig: W. de Gruyter und Co., 1922.) 10s.\*

**McIntosh, Prof. W. C.** A Monograph of the British Marine Annelids. Vol. 4, Part 1: Polychæta—Hermilidae to Sabellidae. *Imp. 4to.* Pp. vii+250+plates 112-127. (London: Dulau and Co., Ltd., 1922.) 50s. net.\*

**Meek, Prof. A.** Essentials of Zoology: For Students of Medicine and First Year Students of Science. *Demy 8vo.* Pp. xii+325. (London: Longmans, Green, and Co., 1922.) 10s. 6d. net.\*

**Oort, Prof. Dr. E. D. van,** Onder Redactie van *Capita Zoologica: Verhandelingen op Systematisch-Zoologisch gebied.* Deel 1, Afl. 1. *6vo.* Pp. 112+7 tafelen aus dem Rijks Museum van Natuurlijke Historie zu Leiden. *Roy. 4to.* Pp. 72. ('s-Gravenhage: M. Nijhoff, 1922.) 6 gld.\*

**Shipley, Sir Arthur E.,** Edited by. The Fauna of British India, including Ceylon and Burma. Birds. Vol. 1. Second edition. By E. C. Stuart Baker. *Med. 8vo.* Pp. xxiii+479. (London: Taylor and Francis, 1922.) 30s.

**Stephenson, Dr. J.** On the Septal and Pharyngeal Glands of the Microdrilli (Oligochaeta). (Transactions of the Royal Society of Edinburgh. Vol. 53, Part 1, No. 12.) *Med. 4to.* Pp. 241-264. (Edinburgh: R. Grant and Son; London: Williams and Norgate, 1922.) 5s.\*

### Agriculture

**Aereboe, Prof. Dr. F.** Neue Düngewirtschaft ohne Auslandsphosphate. (Aereboe: Betriebswirtschaftliche Vorträge aus dem Gebiete der Landwirtschaft. Heft 6.) *Large 8vo.* Pp. 52. (Berlin: P. Parey, 1922.) 15 marks.

**Bennett, Mrs. F.,** and **Rohde, Eleanour S.** A Vegetable Grower's Handbook. *Cr. 8vo.* Pp. x+174. (London: Whittingham and Griggs, Ltd., 1922.) 6s. net.

**Birkett, E.** Zootic Abortion in Bovines and its Origin, True Cause, Prevention, and Cure. Based upon Practical and Scientific Cow Knowledge. With the original Formula to enable all Cattle Breeders to prevent and cure this most serious Scourge. Gl. 8vo. Pp. 31. (Author: Beddlestone Farm, Brook, Ashford, Kent, 1922.) 10s. 6d. net.

**Davidson, H. C.** Vegetable Culture: A Practical Manual. Cr. 8vo. Pp. viii+144. (London: C. Lockwood and Son, 1922.) 4s. 6d. net.

**Ehrenberg, Prof. Dr. P.** Die Bodenkolloide. Eine Ergebnis für die üblichen Lehrbücher der Bodenkunde, Düngerlehre und Ackerbaulehre. 3 vermehrte und verbesserte Auflage. 8vo. Pp. viii+717. (Dresden und Leipzig: Th. Steinkopff, 1922.) 150 marks.

**Fleischer, M.** Die Bodenkunde auf chemisch-physikalischer Grundlage. (Kulturtechnische Bücherei, Band 1.) 5 neubearbeitete Auflage. 8vo. Pp. x+248. (Berlin: P. Parey, 1922.) 160 marks.

**Fournier, L.** Les Stimulants radioactifs en agriculture: Leur rôle dans les engrais. (Paris: Librairie spéciale agricole, 1922.) 3.75 francs.

**Francé, R. H.** Das Leben im Ackerboden. 4. Auflage. 8vo. Pp. 77. (Stuttgart: Franckh'sche Verlag, 1922.) 28 marks.

**Gisevius, P.** Der Kalkhang der deutschen Böden. 8vo. Pp. 16. (Berlin: Verlag "Verein deutscher Kalkwerke," 1922.) 3 marks.

**Goldschmidt, V. M.,** og **Johnsen, E.** Glimmermineralems betydning som kalkkilde for planterne. (Norges geologiske Undersøkelser, Nr. 108.) Pp. 89. (Kristiania: H. Aschehoug and Co., 1922.) 2 kr.

**Johnsen, E.** Om tilgodejorelsen av kalkfeltspatens kallihold. Mit englischen Inhaltsangabe. (Norges geologiske Undersøkelser, Nr. 109.) Pp. 77. (Kristiania: H. Aschehoug and Co., 1922.) 2 kr.

**Kinross, Agnes.** Poultry Keeping. (Bulletin No. 100.) Demy 8vo. Pp. 89. (Glasgow: West of Scotland Agricultural College, 1922.) 1s.\*

**Kinsley, A. T.** Swine Practice. Roy. 8vo. Pp. 374. (London: Baillière, Tindall, and Cox, 1922.) 16s. net.

**Kockerols, J.** Praktisches Rezeptbüchlein für Tierbesitzer und Landwirte nebst Anleitung zur Einrichtung einer tierärztlichen Hausapotheke. 2 vermehrte und verbesserte Auflage. 8vo. Pp. 134. (Neudamm: J. Neumann, 1922.) 40 marks.

**Kreuzpointner, J.** Acht Jahre Gemüsebau ohne Stallmist. Praktische Erfahrungen in der Verwendung der Handelsdünger im Gartenbau. Large 8vo. Pp. 37. (München: Bayerische Gartenzeitung, 1922.) 20 marks.

**Lehnert, Dr. E.** Der Wert der Agglutinationsprüfung und Komplementbindungs-methode beim Paratyphusaborts des Pferdes. Large 8vo. Pp. 88. (Berlin: R. Schoetz, 1922.) 20 marks.

**McConnell, P.** Notebook of Agricultural Facts and Figures for Farmers and Farm Students. Tenth edition, revised and enlarged. Pott 8vo. Pp. 547. (London: C. Lockwood and Son, 1922.) 15s. net.

**Macklin, Prof. T.** Efficient Marketing for Agriculture: Its Services, Methods, and Agencies. Ex. Cr. 8vo. Pp. xviii+418. (London: Macmillan and Co., Ltd., 1922.) 12s. 6d. net.

**Meunier, J.** De la production de la graine de betterave sucrière dans le département des Basses-Pyrénées. 8vo. Pp. 212. (Paris: P. Renouard, 1922.)

**Meyer, Dr. L.** Neuzeitliche Stickstoffdüngung. 8vo. Pp. 51. (Neudamm: J. Neumann, 1922.) 10 marks.

**Otto, Prof. Dr. R.** Düngerlehre. 3 umgearbeitete und erweiterte Auflage. 8vo. Pp. vii+86. (Stuttgart: E. Ulmer, 1922.) 24 marks.

**Pourriau, La Laiterie**: art de traiter le lait, de fabriquer le beurre et les principaux fromages français et étrangers. 7<sup>e</sup> édition, complètement remaniée, mise au courant des progrès modernes, et augmentée, par Prof. L. Ammann. Cr. 8vo. Pp. 640. (Paris: Librairie agricole, 1922.) 15 francs.

**Scott, W.,** with the collaboration of various writers. An Indexed System of Veterinary Treatment: Modern Medical, Surgical, and Biological Therapy. Roy. 8vo. Pp. 647. (London: Baillière, Tindall, and Cox, 1922.) 31s. 6d. net.

**Senner, A.** Naturkunde auf Grundlage der heimischen Scholle. Experimentelle landwirtschaftliche gerichtete Naturlehre für Landschulen. 2 vermehrte und verbesserte Auflage. Large 8vo. Pp. xvi+172. (Heidelberg: W. Ehrig, 1922.) 28 marks.

## Anatomy: Physiology

**Gerwiener, F.** Alkohol und Lungentuberkulose. Large 8vo. Pp. 36. (München: Verlag der Aertztlichen Rundschau, 1922.) 7.50 marks.

**Gouin, R.** Les Aliments du bétail et les intoxications alimentaires. Pott 8vo. Pp. 400. (Paris: J.-B. Baillière et fils, 1922.) 10 francs.

**Gregory, Prof. W. K.** The Origin and Evolution of the Human Dentition. Sup. Roy. 8vo. Pp. xviii+548+15 plates. (Baltimore, Md.: Williams and Wilkins Co., 1922.)\*

**Höber, Prof. Dr. R.** Physikalische Chemie der Zelle und der Gewebe. Fünfte, neubearbeitete Auflage. 1 Hälfte. Med. 8vo. Pp. xv+544. (Leipzig: W. Engelmann, 1922.) 575 marks.\*

**Hopkins, Prof. F. G.** Newer Aspects of the Nutrition Problem. Pp. 19. (New York: Lecomte and Buechner, 1922.) 75 cents.

**Kling, A.** Méthodes actuelles d'expertises employées au laboratoire municipal de Paris et documents sur les matières relatives à l'alimentation. A l'usage de tous les laboratoires d'analyses et des experts-chimistes. Tome V: Eaux et air. Large 8vo. Pp. 181. (Paris: Libr. Dunod, 1922.) 14 francs.

**Schulz, Prof. F. N.** Praktikum der physiologischen Chemie. 6. Auflage. 8vo. Pp. iii+117. (Jena: G. Fischer, 1922.) 18 marks.

**Stiles, Prof. F. G.** Human Physiology: A Text-Book for High Schools and Colleges. Third edition, revised. Ex. Cr. 8vo. Pp. 425. (Philadelphia and London: W. B. Saunders Co., 1922.) 12s. net.

**Variot, Dr. G.** Les Laites condensés et leur utilisation dans l'alimentation humaine. (Monographies techniques.) 8vo. Pp. 30. (Paris: Editions médicales, 1922.) 2 francs.

**Waller, Dr. A. D.** The Electrical Action of the Human Heart. Edited by A. M. Waller. Demy 8vo. Pp. ix+103. (London: University of London Press, Ltd., 1922.) 7s. 6d. net.\*

**Walmley, Prof. T.** A Manual of Practical Anatomy: A Guide to the Dissection of the Human Body. In 3 parts. Part 3: The Head and Neck. Demy 8vo. Pp. viii+272. (London: Longmans, Green, and Co., 1922.) 10s. 6d. net.\*

**Wlassak, R.** Grundriss der Alkoholfrage. 4to. Pp. iv+108. (Leipzig: S. Hirzel, 1922.) 30 marks.

## Anthropology: Ethnology

**Brewster, A. B.** The Hill Tribes of Fiji: A Record of Forty Years' Intimate Connection with the Tribes of the Mountainous Interior of Fiji, with a Description of their Habits in War and Peace, Methods of Living, Characteristics Mental and Physical, from the Days of Cannibalism to the Present Time. Demy 8vo. Pp. 308. (London: Seeley, Service, and Co., Ltd., 1922.) 21s. net.

**Longnon, A.** Les Noms de lieu de la France: leur origine, leur signification, leurs transformations. Deuxième fascicule: Noms de lieu d'origine saxonne, burgonde, visigothique, franque, scandinave, bretonne et basque. 8vo. Pp. 177-336. (Paris: E. Champion, 1922.)

**Loon, H. van.** The Story of Mankind. Med. 8vo. Pp. xviii+492+17 plates. (London: G. G. Harrap and Co., Ltd., 1922.) 12s. 6d. net.

**Mills, J. P.** The Lhota Nagas. With an Introduction and Supplementary Notes by J. H. Hutton. (Published by direction of the Government of Assam.) Demy 8vo. Pp. xxxix+255. (London: Macmillan and Co., Ltd., 1922.) 25s. net.\*

**Springett, B. H.** Secret Sects of Syria and the Lebanon: A Consideration of their Origin, Creeds, and Religious Ceremonies, and their Connection with and Influence upon Modern Freemasonry. Demy 8vo. Pp. 351. (London: G. Allen and Unwin, Ltd., 1922.) 12s. 6d. net.\*

**White, W. G.** The Sea Gypsies of Malaya: An Account of the Nomadic Mawken People of the Mergui Archipelago; with a Description of their Ways of Living, Customs, Habits, Boats, Occupations, etc. Demy 8vo. Pp. 318. (London: Seeley, Service, and Co., Ltd., 1922.) 21s. net.\*

**Wigram, Rev. W. A., and Wigram, Sir Edgar T. A.** The Cradle of Mankind: Life in Eastern Kurdistan. Cheap edition. 8vo. Pp. xi+430. (London: A. and C. Black, Ltd., 1922.) 15s. net.

### Philosophy: Psychology

**Bennett, R. A.** Suggestion and Common Sense. Cr. 8vo. Pp. 105. (Bristol: J. Wright and Sons, Ltd.; London: Simpkin, Marshall, and Co., Ltd., 1922.) 6s. net.

**Drever, Dr. J.** An Introduction to the Psychology of Education. (Modern Educator's Library.) Cr. 8vo. Pp. viii+227. (London: E. Arnold and Co., 1922.) 6s. net.

**Dunlap, Prof. K.** Elements of Scientific Psychology. Roy. 8vo. Pp. 368. (St. Louis, Mo.: The C. V. Mosby Co., 1922.) 3.50 dollars.

**Henning, Prof. Dr. H.** Einsteins Relativitätslehre im Lichte der experimentellen Psychologie und des philosophischen Realismus. Pp. ii+48. (Leipzig: J. A. Barth, 1922.) 48 marks.

**Hollander, B.** The Psychology of Misconduct, Vice, and Crime. Cr. 8vo. Pp. 220. (London: G. Allen and Unwin, Ltd., 1922.) 7s. 6d. net.

**Laplace, P.-S.** Essai philosophique sur les probabilités. (Collection des Maîtres de la Pensée Scientifique, No. 10.) Deux volumes. Pp. xii+103; 108. (Paris: Gauthier-Villars et Cie, 1922.) 6 francs.

**Lindsay, J.** Great Philosophical Problems. Cr. 8vo. Pp. 288. (London: W. Blackwood and Sons, 1922.) 10s. 6d. net.

**Micklem, E. R.** Miracles and the New Psychology: A Study in the Healing Miracles of the New Testament. Cr. 8vo. Pp. 143. (London: Oxford University Press, 1922.) 7s. 6d. net.\*

**Mukerji, Prof. N. C.** The Ethical and Religious Philosophy of Idealism. Cr. 8vo. Pp. xix+115+149. (Allahabad: North India Christian Tract and Book Society, 1922.) 2.8 rupees.

**Peddie, Prof. W.** On Self Light, Fatigue, Inhibition and Recurrent Visual Images. (Proceedings of the Royal Society of Edinburgh, Session 1921-1922, Vol. 42, Part 3, No. 20.) Sup. Roy. 8vo. Pp. 319-320. (Edinburgh: R. Grant and Son; London: Williams and Norgate, 1922.) 6d.\*

**Pfister, Dr. O.** Expressionism in Art: Its Psychological and Biological Basis. Authorised Translation by Barbara Low and Dr. M. A. Mügge. Cr. 8vo. Pp. viii+272. (London: Kegan Paul and Co., Ltd., 1922.) 6s. 6d. net.\*

**Rignano, E.** Come funziona la nostra intelligenza. (Attualità Scientifiche, N. 30.) Med. 8vo. Pp. 47. (Bologna: N. Zanichelli, 1922.)\*

**Rogers, A. K.** English and American Philosophy since 1800: A Critical Survey. Med. 8vo. Pp. xv+468. (New York: The Macmillan Co.; London: Macmillan and Co., Ltd., 1922.) 10s. net.

**Shafer, R.** Progress and Science: Essays in Criticism. Ex. Cr. 8vo. Pp. xii+243. (New Haven: Yale University Press; London: Oxford University Press, 1922.) 12s. net.\*

**Smith, M. H.** The Psychology of the Criminal. Cr. 8vo. Pp. vii+182. (London: Methuen and Co., Ltd., 1922.) 6s. net.

**Steiner, R.** The Philosophy of Spiritual Activity: A Modern Philosophy of Life developed by Scientific Methods. Authorised translation by Prof. and Mrs. R. F. A. Hoernle. 8vo. Pp. 397. (London: G. P. Putnam's Sons, 1922.) 12s. 6d. net.

**Tassy, E., and Leris, P.** La Cohésion des formes intellectuelles. Gl. 8vo. Pp. 80. (Paris: Gauthier-Villars et Cie, 1922.) 2.50 francs.

**Taylor, A. E.** Plato. (Philosophies Ancient and Modern.) Gl. 8vo. Pp. vii+151. (London: Constable and Co., Ltd., 1922.) 2s. net.

**Underhill, Evelyn.** The Life of the Spirit and the Life of To-day. Cr. 8vo. Pp. xii+241. (London: Methuen and Co., Ltd., 1922.) 7s. 6d. net.

**Villey, P.** The World of the Blind: A Psychological Study. Cr. 8vo. Pp. 400. (London: Simpkin, Marshall, and Co., Ltd., 1922.) 5s. net.

**Wentscher, E.** Das Problem des Empirismus dargestellt an John Stuart Mill. Med. 8vo. Pp. viii+153. (Bonn: A. Marcus und E. Webers Verlag, 1922.) 4s.\*

**Werner, H.** Grundfragen der Intensitätspychologie. Pp. x+251. (Leipzig: J. A. Barth, 1922.) 210 marks.

### Bacteriology: Hygiene

**Bruynoghe, R.** Handboek der Bakteriologie. 8vo. Pp. vii+355. (Löwen: A. Uystpruyt; Amsterdam: Feikema, Caarelsen, and Co., 1922.) 25 francs.

**Department of Scientific and Industrial Research:** Food Investigation Board. Special Report No. 11: The Bacteriology of Canned Meat and Fish. By Dr. Wm. G. Savage, R. F. Hunwicke, and R. B. Calder. Roy. 8vo. Pp. iii+72. (London: H.M. Stationery Office, 1922.) 2s. 6d. net.\*

**Greaves, Prof. J. E.** Agricultural Bacteriology. Med. 8vo. Pp. 437. (London, Bombay, and Sydney: Constable and Co., Ltd., 1922.) 21s. net.\*

**Hardenburg, W. E.** Mosquito Eradication. Med. 8vo. Pp. ix+248. (New York and London: McGraw-Hill Book Co., Inc., 1922.) 15s.\*

**Steadman, F. St. J.** Notes on Bacteriology for Dental Students. Demy 8vo. Pp. 48. (London: J. Bale, Sons, and Danielsson, Ltd., 1922.) 3s. 6d. net.

**Walbum, L. E.** Studier over Dannelsen af de bakterielle Toxiner. (Stafylokok og Difteritoxin.) Large 8vo. Pp. 198. (Kopenhagen: Levin og Munksgaard, 1922.) 10 kr.

### Medicine: Surgery

**Apert.** Vaccins et sérums. (Bibliothèque des connaissances médicales.) Pott 8vo. Pp. iv+282. (Paris: E. Flammarion, 1922.) 7.50 francs.

**Bang, Prof. I.** Mikromethoden zur Blutuntersuchung. 3 Auflage. 4to. Pp. xi+48. (München und Wiesbaden: J. F. Bergmann, 1922.) 24 marks.

**Bertin, P.** L'Amio-arséno-phénol (132) dans le traitement de la syphilis par la voie intra-musculaire. 8vo. Pp. 107. (Paris: Editions médicales, 1922.)

**Bezancon, Prof. Fr.** Les Bases actuelles du problème de la tuberculose. (Sciences et Civilisation.) 8vo. Pp. vi+198. (Paris: Gauthier-Villars et Cie, 1922.) 7 francs.

**Bier, A., Braun, H., and Kummell, H.,** Herausgegeben von. Chirurgische Operationslehre. Vierte und fünfte vermehrte Auflage. In fünf Bänden. Band I: Allgemeine Operationslehre, Operationen an Kopf und Wirbelsäule. Pp. xx+681. (Leipzig: J. A. Barth, 1922.) 1500 marks.

**Boas, Dr. H.** Die Wassermannsche Reaktion mit besonderer Berücksichtigung ihrer klinischen Verwertbarkeit. 3 Auflage. Large 8vo. Pp. viii+176. (Berlin: S. Karger, 1922.) 36 marks.

**Boob, E.** Techniques pratiques d'examen du liquide céphalo-rachidien des syphilitiques. 8vo. Pp. 91. (Le Havre: Impr. R. Le Grand, 1922.)

**Brand, A. T.** Cancer: Its Cause, Treatment, and Prevention. Demy 8vo. Pp. viii+120. (London: J. Bale, Sons, and Danielsson, Ltd., 1922.) 8s. 6d. net

**Comrie, J. D.** Black's Medical Dictionary. Seventh edition. 8vo. Pp. 870. (London: A. and C. Black, Ltd., 1922.) 15s. net.

**Coniver, L.** Contribution à la recherche toxicologique des composés arsenicaux organiques. 8vo. Pp. 71. (Nancy: Impr. A. Golin, 1922.)

**Cotoni, L., Truche, G., and Raphael, A.** Pneumocoques et affections pneumococciques. (Monographies de l'Institut Pasteur.) 8vo. Pp. 224. (Paris: Masson et Cie, 1922.) 10 francs.

**Dreuw, H.** Das wahre Gesicht der Wassermannschen Blutprobe. Large 8vo. Pp. 6. (Berlin: Ritter-Verlag, 1922.) 5 marks.

- Ferré, L.** Traitement de la tuberculose irienne par les rayons X. 8vo. Pp. 63. (Trévoux: Impr. J. Jeannin, 1922.)
- Finsel, O.** Praktische Hamdiagnostik. 2. Auflage. Large 8vo. Pp. 40. (Leipzig: Krüger and Co., 1922.) 14 marks.
- Fishberg, M.** Pulmonary Tuberculosis. Third edition, revised. Roy. 8vo. Pp. 891. (London: H. Kimpton, 1922.) 42s. net.
- Gautier, L.** Histoire et évolution de l'enseignement de la pharmacie en France. 8vo. Pp. 40. (Mulhouse: Impr. J. Brinkmann, 1922.)
- Gendraud, F. J.** Le Traitement par la digitale des hypertendus décompensés. 8vo. Pp. 37. (Bordeaux: Impr. Y. Cadoret, 1922.)
- Gilbert, A., et Michel, Ch.** Formulaire pratique de thérapeutique et de pharmacologie. Ancien formulaire de Dujardin-Beaumetz et Yvon. 29 édition, entièrement refondue et conforme au supplément du Codex (1920). Fcap. 8vo. Pp. 934. (Paris: O. Doin, 1922.) 10 francs.
- Gourdeau, E. G. F.** Contribution à l'étude du traitement d'éprouve des états cachectiques du nouveau-né présumé syphilitique par les arsénobenzols. 8vo. Pp. 48. (Paris: Impr. Le François, 1922.)
- Guillain, G., Laroche, G., et Lechelle, P.** La Réaction du benjoin colloïdal et les réactions colloïdales du liquide céphalo-rachidien. Large 8vo. Pp. 146. (Paris: Masson et Cie, 1922.) 12 francs.
- Harington, Sir John.** The School of Salerno: Regimen Sanitatis Salernitanum. The English Version. History of the School of Salerno, by Dr. F. R. Packard; and a Note on the Prehistory of the Regimen Sanitatis, by Dr. F. H. Garrison. Ex. Cr. 8vo. Pp. 216. (London: Oxford University Press, 1922.) 14s. net.\*
- Heinigkes, C.** Handbuch der homöopathischen Arzneiwirkungslehre. 3 vermehrte Auflage bearbeitete von P. Klien. 8vo. Pp. xv + 758. (Leipzig: Dr. W. Schwabe, 1922.) 280 marks.
- Hertzler, Prof. A. E.** Diseases of the Thyroid Gland. Pp. 250. (London: H. Kimpton; St. Louis, Mo.: The C. V. Mosby Co., 1922.) 25s. net.
- Hézar, A.** Réflexions sur quelques sources sulfatées calciques des Pyrénées et de Capvern en particulier. 8vo. Pp. 46. (Paris: Jouve et Cie, 1922.)
- History of the Great War:** Based on Official Documents. Medical Services: Surgery of the War. Vol. 1. Edited by Maj.-General Sir W. G. Macpherson, Maj.-General Sir A. A. Bowlby, Maj.-General Sir C. Wallace, and Col. Sir C. English. Demy 8vo. Pp. vii + 618. (London: H.M. Stationery Office, 1922.) 25s. net.\*
- Jalenques, J.** Gangrène humide diabétique et sérothérapie antigangreneuse. 8vo. Pp. 40. (Paris: Jouve et Cie, 1922.)
- Lacapère.** Le Traitement de la syphilis par les composés arsenicaux. Avec la collaboration du Dr. Ch. Laurent. 3<sup>e</sup> édition, revue et augmentée. 8vo. Pp. 238. (Paris: Masson et Cie, 1922.) 8 francs.
- Larsonneau, A.** Recherches sur les alcaloïdes volatils des feuilles de belladone: Leur importance dans l'appréciation de la valeur pharmaco-dynamique de cette drogue. 8vo. Pp. 51. (Mayenne: Impr. J. Leclurel, 1922.)
- Laux, W.** Preussische Apothekerordnung auf Grund der zurzeit geltenden gesetzlichen Bestimmungen für Apotheker und Medizinal-Beamte zusammengesetzt. 5 völlig neu bearbeitete Auflage. 8vo. Pp. viii + 107. (Berlin und Wien: Urban und Schwarzenberg, 1922.) 30 marks.
- Lereboullet, P., Harvier, P., Carrion, H., and Guillaume, A. G.** Endocrine Glands and the Sympathetic System. Translated by F. R. Mason and D. E. Ayres. Roy. 8vo. Pp. 378. (London: J. B. Lippincott Co., 1922.) 25s. net.
- Lespinne et Wydooghe.** Étude de deux cas de purpura hémorragique consécutifs aux injections d'arsénobenzène. 8vo. Pp. 20. (Troyes: Grande Impr., 1922.)
- Levy-Bing, Gerbay, et Philippeau.** Premiers essais de thérapeutique bismuthique. 8vo. Pp. 19. (Troyes: Grande Imprimerie, 1922.)
- Lory, G.** La Radiumthérapie des fibro-myomes utérins. 8vo. Pp. 139. (Paris: Editions de "La Vie universitaire," 1922.)
- Macmichael, Dr. W.** The Gold-Headed Cane. New edition. Ex. Cr. 8vo. Pp. xxvii + 261. (London: Oxford University Press, 1922.) 16s. net.\*

**Meyer, H. H., and Gottlieb, R.** Die experimentelle Pharmakologie als Grundlage der Arzneibehandlung. 6 durchgesehene Auflage. Large 8vo. Pp. xx + 694. (Berlin und Wien: Urban und Schwarzenberg, 1922.) 366 marks.

**Meyniard, J. A. C. A.** Contribution à l'étude des accidents causés par les arsénobenzols envisagée au point de vue médico-légal. 8vo. Pp. 47. (Paris: Jouve et Cie, 1922.)

**Mills, G. P., and Humphreys, H.** A Text-book of Surgery for Dental Students. Third edition. 8vo. Pp. 356. (London: E. Arnold and Co., 1922.) 14s. net.

**Ministry of Health.** Reports on Public Health and Medical Subjects, No. 11: Report on Encephalitis Lethargica. Being an Account of further enquiries into the Epidemiology and Clinical Features of the Disease: including an Analysis of over 1250 Reports on Cases notified in England and Wales during 1919 and 1920, together with a comprehensive Bibliography of the Subject. By Allan C. Parsons; with Contributions by Dr. A. S. MacNalty and J. R. Perdrau. Roy. 8vo. Pp. x + 344. (London: H.M. Stationery Office, 1922.) 10s. net.\*

**Moulet, C.** Traitement de l'urétrite chronique par l'ionisation. 8vo. Pp. 39. (Paris: Impr. Le François, 1922.)

**Mourgues, J. B.** Contribution à l'étude du vaccin mixte de Delbet: Les idées modernes sur l'immunisation active. 8vo. Pp. 112. (Nancy: Impr. nancienne, 1922.)

**Muffat, R.** Du traitement des mérites par les sels de terres rares (Thorium et Didyme). 8vo. Pp. 32. (Paris: Vigot frères, 1922.)

**Orth, F. J.** Biochemische Behandlung der Krankheiten. Mit Symptomenangabe dargestellt in alphabetischer Ordnung nach der 3. Auflage des französischen Werkes "Description et emploi des douze médicaments biochimiques" mit vielen Zusätzen. 2. Auflage. 8vo. Pp. 78. (Leipzig: G. Engel, 1922.) 15 marks.

**Packard, Dr. F. R.** Life and Times of Ambroise Pare (1510-1590): with a New Translation of his Apology and an Account of his Journeys in Divers Places. Med. 8vo. Pp. xii + 297. (London: Oxford University Press, 1922.) 28s. net.\*

**Perès, M.** La Réaction du benjoin colloïdal dans le liquide céphalorachidien normal et pathologique. 8vo. Pp. 76. (Toulouse: Impr. E. H. Guitard, 1922.)

**Portmann, G., et Lachapèle, A. P.** La Koentgenographie des tumeurs malignes en oto-rhino-laryngologie. 8vo. Pp. 107. (Paris: A. Maloine et fils, 1922.) 5 francs.

**Pybus, F. C.** The Surgical Diseases of Children: A Handbook for Students and Practitioners. 8vo. Pp. 426. (London: H. K. Lewis and Co., 1922.) 18s. net.

**Rosenberg, H.** Pharmakopendium. 4to. Pp. vi + 666. (Berlin und Wien: Urban und Schwarzenberg, 1922.) 477 marks.

**Rousseau, J.** Les Diurétiques dans le traitement de l'ascite cirrhotique. Le chlorure de calcium. 8vo. Pp. 46. (Paris: Jouve et Cie, 1922.)

**Schilling, V.** Das Blutbild und seine klinische Verwertung. (Mit Einschluß der Tropenkrankheiten.) Anleitung zur mikroskop. Blutuntersuchung. 2. vermehrte Auflage. Large 8vo. Pp. viii + 172. (Jena: G. Fischer, 1922.) 110 marks.

**Schneider, J.** Biochemischer Hausarzt. Neubearb. und verm. von Paul Klien. 4. Auflage. 8vo. Pp. xvi + 348. (Leipzig: Dr. W. Schwabe, 1922.) 45 marks.

**Tappeiner, H.** Manuale di materia medica e farmacoterapia. 2. edizione sulla 10. edizione tedesca. Riordinata, accresciuta e adatta alla nuova Farmacopea ufficiale italiana dal Dr. G. M. Piccinini. Versione del Dr. C. Cavina. 8vo. Pp. xx + 548. (Turin: Unione Tipografico-Editrice Torinese, 1922.) 36 lire.

**Vincent.** Médications sulfurées. Fcap. 8vo. Pp. 120. (Paris: J.-B. Baillière et fils, 1922.) 4.50 francs.

#### Miscellaneous

**Advancement of Science: 1922.** The. Addresses delivered at the 90th Annual Meeting of the British Association for the Advancement of Science, Hull, September 1922. Demy 8vo. Pp. 15 + 9 + 24 + 30 + 15 + 12 + 27 + 17 + 14 + 15 + 14 + 11 + 15 + 34. (London: J. Murray, 1922.) 6s. net.\*

- Anderton, B.** Sketches from a Library Window. Med. 8vo. Pp. vi+182. (Cambridge: W. Heffer and Sons, Ltd.; London: Simpkin, Marshall, and Co., Ltd., 1922.) 10s. 6d. net.\*
- Angé, L.** La Technique moderne de la vente. Manuel de publicité à l'usage des commerçants et des industriels, des professionnels de la publicité et des écoles de commerce. (Bibliothèque Professionnelle.) Pott 8vo. Pp. 314. (Paris: J.-B. Baillière et Fils, 1922.) 10 francs net.\*
- Blänsdorf, E.** Bleiliteratur. Veröffentlichungen über Bleivergiftung, Spezialarbeiten und Merkblätter. Text-angabe den Bleiverordnungen für das Deutsche Reich, Deutschösterreich und ausserdeutsche Staaten. Large 8vo. Pp. iv+108. (Berlin: J. Springer, 1922.) 87 marks.
- Cescinsky, H.** With an Introduction by a Chinese Furniture: a Series of Examples from Collections in France. Roy. 4to. Pp. 20+54 plates. (London: Benn Bros., Ltd., 1922.) 50s. net.\*
- Crawford, O. G. S.** Notes on Archaeological Information incorporated in the Ordnance Survey Maps. Part I: The Long Barrows and Stone Circles in the Area covered by Sheet 8 of the  $\frac{1}{4}$ -inch Map (the Cotswolds and the Welsh Marches.) (Ordnance Survey. Professional Papers, New Series, No. 6.) Roy. 4to. Pp. 11+1 plate+1 map. (London: H.M. Stationery Office, 1922.) 4s. 6d. net.\*
- Dalton Plan Assignments. II:** Mathematics and Science. Compiled by the Staff of Streatham County Secondary School for Girls. With an Introduction by Rosa Bassett. Cr. 8vo. Pp. 71. (London: G. Bell and Sons, Ltd., 1922.) 2s. net.
- Dark, S.** The New Reading Public: a Lecture delivered under the Auspices of "The Society of Bookmen." Cr. 8vo. Pp. 22. (London: G. Allen and Unwin, Ltd., 1922.) 1s. net.\*
- Doke, C. M.** The Grammar of the Lamba Language. (Published under the Joint Auspices of the University of the Witwatersrand and the Council of Education, Witwatersrand.) Gl. 8vo. Pp. ix+157. (London: Kegan Paul and Co., Ltd., 1922.) 6s. net.\*
- Drury, A.,** Compiled by. World Metric Standardization: an Urgent Issue. A volume of Testimony urging World-wide Adoption of the Metric Units of Weights and Measures—Meter-Liter-Gram. Med. 8vo. Pp. 54. (San Francisco: World Metric Standardization Council, 1922.) 5 dollars.\*
- Fabbro e Marco.** Nozioni di fisica, chimica, storia naturale. (Biblioteca di Scienze fisiche, matematiche e naturali.) Vol. 2. Neudruck. Fcap. 8vo. Pp. 184. (Turin: G. B. Paravia, 1922.) 7,50 lire.
- Fournier d'Albe, Dr. E. E.** The Goligher Circle, May to August, 1921. With an Appendix containing Extracts from the Correspondence of the late Dr. W. J. Crawford and others. Demy 8vo. Pp. 81+plates. (London: J. M. Watkins, 21 Cecil Court, 1922.) 7s. 6d. net.\*
- Freysoeldt, G.** Die Tabakmärkte. Small 8vo. Pp. 63. (Dresden: Verlag der "Tabakwirtschaftlichen Rundschau," 1922.) 30 marks.
- Gibbs, Dr. W. E.** The Fishing Industry. (Pitman's Common Commodities and Industries.) Cr. 8vo. Pp. viii+135. (London: Sir I. Pitman and Sons, Ltd., 1922.) 3s. net.\*
- Grey, E.** Reminiscences, Tales, and Anecdotes of the Laboratories, Staff, and Fields, 1872-1922: Rothamsted Experimental Station. Demy 8vo. Pp. 155. (Harpden: Rothamsted Experimental Station, 1922.) 5s.
- Haehl, R.** Samuel Hahnemann. Sein Leben und Schaffen. Unter Mitwirkung von K. Schmidt-Buhl. 2 Bände. 4to. Band I. Pp. xvi+508. Band 2. Pp. xvi+527. (Leipzig: Dr. W. Schwabe, 1922.) 560 marks.
- Jackson, T. C., and Hustwick, W.** The Principles of Accounts. Cr. 8vo. Pp. viii+237. (London: University Tutorial Press, Ltd., 1922.) 3s.
- Lea, J. W.** Britain's Decline: Her Economic Disorder and its Only Remedy. Med. 8vo. Pp. xiv+79. (Birmingham: Cornish Bros., Ltd., 1922.) 1s. net.\*
- Lewin, K.** Der Begriff der Genese in Physik, Biologie und Entwicklungsgeschichte. Large 8vo. Pp. xiii+240. (Berlin: J. Springer, 1922.) 136 marks.
- Lodge, Sir O. J.** Raymond Revised. A new and abbreviated edition of "Raymond, or Life and Death," with an additional chapter. Cr. 8vo. Pp. xv+224. (London: Methuen and Co., Ltd., 1922.) 6s. net.\*
- McDougall, A. T.** Some of Nature's Giant Forces. (Science in Everyday Life.) Gl. 8vo. Pp. vii+131. (London: Sir I. Pitman and Sons, Ltd., 1922.) 2s. 6d.
- Maurain, Prof. C.** Répertoire des laboratoires français. Med. 8vo. Pp. 55. (Paris: Inst. Tech., 1922.) 2 francs.
- Maxwell, Sir H.** Memories of the Months. Seventh Series. Ex. Cr. 8vo. Pp. xiv+260. (London: E. Arnold and Co., 1922.) 10s. 6d. net.\*
- Milani, G.** Manuale di scienze naturali e delle loro principali applicazioni ad uso delle scuole normali e tecniche. Parte II: Fisica, chimica, mineralogia, meteorologia, geografia fisica. (Biblioteca di scienze fisiche, matematiche e naturali.) 17 edizione. Fcap. 8vo. Pp. 252. (Turin: G. B. Paravia e C., 1922.) 9 lire.
- Mitchell, C. A.** Documents and their Scientific Examination. (Griffin's Scientific Text-books.) Cr. 8vo. Pp. 227. (London: C. Griffin and Co., Ltd., 1922.) 10s. 6d. net.
- Palmer, A. R.** Finance. Vol. 1: Banking, Stock-broking, Currency, Exchange. (Bell's Handbooks of Commerce and Finance.) Cr. 8vo. Pp. xiii+189. (London: G. Bell and Sons, Ltd., 1922.) 5s. net.\*
- Pearson, K.** Francis Galton, 1822-1922: A Centenary Appreciation. (Department of Applied Statistics, University College, London: Questions of the Day and of the Fray, No. 11.) Demy 8vo. Pp. 23. (London: Cambridge University Press, 1922.) 2s. net.\*
- Petrovitch, M.** Notice sur les travaux scientifiques de M. Michel Pétróvitch, 1894-1921. (Académie Royale de Serbie.) 8vo. Pp. ix+152. (Paris: Gauthier-Villars et Cie, 1922.)
- Picard, E.** La Vie et l'œuvre de Pierre Duham. 4to. Pp. 58. (Paris: Gauthier-Villars et Cie, 1922.) 7 francs.
- Sheppard, T.** Edited by. Handbook to Hull and the East Riding of Yorkshire. Prepared for the Members of the British Association for the Advancement of Science on the Occasion of their Visit to Hull in September 1922. Cr. 8vo. Pp. viii+532. (London and Hull: A. Brown and Sons, Ltd., 1922.)\*
- Soddy, Prof. F.** Cartesian Economics: The Bearing of Physical Science upon State Stewardship. Two Lectures to the Students' Unions of Birkbeck College and the London School of Economics, November 10 and 17, 1921. Gl. 8vo. Pp. 32. (London: Hendersons, 66 Charing Cross Road, 1922.) 6d.\*
- Subject Index** to Periodicals, 1920, The. A: Theology and Philosophy (including Folk-Lore). Roy. 4to. Pp. 98. (London: Library Association, 33 Bloomsbury Square, 1922.) 6s. net.\*
- Sudhoff, K.** Hundert Jahre Deutscher Naturforscherversammlungen. Gedächtnisschrift zur Jahrdundert-Tagung der Gesellschaft Deutscher Naturforscher und Ärzte. Large 8vo. Pp. 80+8 Tafeln. (Leipzig: F. C. W. Vogel, 1922.) 100 marks.
- Walker, J. E., and Foster, R. B.** Patents for Inventions. Demy 8vo. Pp. xiii+377. (London: Sir I. Pitman and Sons, Ltd., 1922.) 21s. net.\*
- Water-Power** in the British Empire. The Reports of the Water-Power Committee of the Conjoint Board of Scientific Societies. Cr. 8vo. Pp. ix+54. (London, Bombay, and Sydney: Constable and Co., Ltd., 1922.) 3s. 6d. net.\*
- Waugh, F. A.** Textbook of Landscape Gardening: Designed especially for the Use of Non-professional Students. Roy. 8vo. Pp. xxi+344. (New York: J. Wiley and Sons, Inc.; London: Chapman and Hall, Ltd., 1922.) 25s. net.\*
- White, E. G.** The Voice Beautiful in Speech and Song: A Consideration of the Capabilities of the Vocal Cords and their Work in the Art of Tone Production. Third edition. Demy 8vo. Pp. viii+166. (London and Toronto: J. M. Dent and Sons, Ltd., 1922.) 7s. 6d. net.\*
- Williamson, H.** Dandelion Days. Cr. 8vo. Pp. xiii+299. (London: W. Collins, Sons, and Co., Ltd., 1922.) 7s. 6d. net.\*



## Recent Scientific and Technical Books

Volumes marked with an asterisk have been received at "NATURE" Office.

## Mathematics

- Bauer, H.** Mathematische Einführung in die Gravitationstheorie Einsteins nebst einer exakten Darstellung ihrer wichtigsten Ergebnisse. Med. 8vo. Pp. vii+97. (Leipzig und Wien: Franz Deuticke, 1922.) 40 marks.
- Borchardt, W. G.** Commercial Arithmetic. Cr. 8vo. Pp. viii+200+xxiv. (London: Rivingtons, 1922.) 3s. 6d.\*
- Edwards, J. A.** A Treatise on the Integral Calculus: with Applications, Examples and Problems. Vol. 2. Demy 8vo. Pp. xv+989. (London: Macmillan and Co., Ltd., 1922.) 50s. net.\*
- Einstein, A.** The Meaning of Relativity: Four Lectures delivered at Princeton University, May 1921. Translated by E. P. Adams. Cr. 8vo. Pp. v+123. (London: Methuen and Co., Ltd., 1922.) 5s. net.\*
- Kraitchik, M.** Théorie des nombres. Roy. 8vo. Pp. ix+229. (Paris: Gauthier-Villars et Cie, 1922.) 25 francs.\*
- Lorentz, H. A., Einstein, A., Minkowski, H.** Das Relativitätsprinzip. Eine Sammlung von Abhandlungen. Vierte, vermehrte Auflage. Med. 8vo. Pp. 159. (Leipzig: B. G. Teubner, 1922.) 40 marks.
- Mann, H. J., and Norman, J. S.** Algebra. Cr. 8vo. Pp. vii+262. (London: The Year Book Press, Ltd., 1922.) 4s. 6d. net; without Answers, 4s. net.
- Michel, F., et Potron, M.** La Composition de mathématiques dans l'examen d'admission à l'École Polytechnique de 1901 à 1921. Roy. 8vo. Pp. xii+452. (Paris: Gauthier-Villars et Cie, 1922.) 40 francs.\*
- Murnaghan, F. D.** Vector Analysis and the Theory of Relativity. Med. 8vo. Pp. x+125. (Baltimore: The Johns Hopkins Press, 1922.)\*
- Palmer, A. R.** Finance. Vol. 2: Logarithms; Compound Interest (Long Term); Progressions; Annuities (Certain and Contingent, Net Premiums); The Use of the Calculus. (Bell's Handbooks of Commerce and Finance.) Cr. 8vo. Pp. xi+128. (London: G. Bell and Sons, Ltd., 1922.) 4s. net.\*
- Papers set in the Mathematical Tripos, Part I, in the University of Cambridge, 1918-1922.** Cr. 8vo. Pp. 77. (Cambridge: At the University Press, 1922.) 3s. net.\*
- Pearson, E. S.** Table of the Logarithms of the Complete  $\Gamma$ -Function (for Arguments 2 to 1200, *i.e.* beyond Legendre's Range). (Department of Statistics (Computing Section), University of London, University College. Tracts for Computers, No. 8.) Med. 8vo. Pp. x+16. (London: Cambridge University Press, 1922.) 3s. 9d. net.\*
- Potter, F. F.** The Teaching of Arithmetic. Cr. 8vo. Pp. xiii+468. (London: Sir I. Pitman and Sons, Ltd., 1922.) 7s. 6d. net.
- Warnant, L.** Les Théories d'Einstein: Essai de réfutation; Examen critique. Gl. 8vo. Pp. 144. (Paris: F. Alcan, 1922.) 6 francs.

## Mechanics: Mechanical Engineering

- Bouzy, G.** L'Automobile. (Collection Caillard.) Cr. 8vo. Pp. 336. (Paris: Libr. Eyrolles, 1922.) 8 francs.
- Haag, J.** Cours complet de mathématiques spéciales. Tome 3: Mécanique. Roy. 8vo. Pp. viii+190. (Paris: Gauthier-Villars et Cie, 1922.) 12 francs.\*
- Jamieson, A.** A Text-book of Applied Mechanics. Vol. 2: Strength of Materials. Revised by E. S. Andrews. (Griffin's Scientific Text-books.) Tenth edition. Cr. 8vo. Pp. 297. (London: C. Griffin and Co., Ltd., 1922.) 6s. net.
- Kearton, W. J.** Steam Turbine Theory and Practice: a Text-Book for Engineering Students. (The Specialist's Series.) Demy 8vo. Pp. xvi+456. (London: Sir I. Pitman and Sons, Ltd., 1922.) 15s. net.\*
- King, H. W., and Wisler, C. O.** Hydraulics. Med. 8vo. Pp. vii+237. (New York: J. Wiley and Sons, Inc., 1922.) Chapman and Hall, Ltd., 1922.) 13s. 6d. net.

- Latham, E.** Marine Works: a Practical Treatise for Maritime Engineers, Landowners and Public Authorities. Demy 8vo. Pp. xii+174. (London: C. Lockwood and Son, 1922.) 16s. net.\*
- Lefèvre, A., Rousset, A., et Thellesme, J. de.** Pour l'ajusteur mécanicien. Gl. 8vo. Pp. viii+207. (Paris: Libr. Dunod, 1922.) 7 francs.
- Lefranc, J. A.** Les Avions. (Bibliothèque des Merveilles.) Fcap. 8vo. Pp. 192. (Paris: Hachette et Cie, 1922.) 6 francs.
- Ministère de l'Agriculture.** Direction générale des Eaux et Forêts (2<sup>e</sup> partie). Service des Grandes Forces Hydrauliques (Région du Sud-Ouest). Résultats obtenus pour le bassin du Salat pendant les années 1917 et 1918. Tome VII, Fascicule D. Sup. Roy. 8vo. Pp. 48+54 charts. Résultats obtenus pour le bassin du Salat. Tome II bis, Fascicule D. Sup. Roy. 8vo. Pp. iv+37 charts. (Paris: Ministère de l'Agriculture, 1922.)\*
- Münzinger, F.** Die Leistungssteigerung von Grossdampfesseln: Eine Untersuchung über die Verbesserung von Leistung und Wirtschaftlichkeit und über neuere Bestrebungen im Dampfkesselbau. (Berlin: J. Springer, 1922.) 240 marks.
- Norris, A. H. E.** Experimental Mechanics and Physics. With Chapters on Chemistry, by A. W. Anson. Seventh edition. Cr. 8vo. Pp. viii+204. (London: Mills and Boon, Ltd., 1922.) 2s. 6d. net.\*
- Wimperis, H. E.** The Internal Combustion Engine: a Text-Book for the Use of Students and Engineers. Fourth edition (revised and enlarged). Demy 8vo. Pp. xvi+320. (London, Bombay and Sydney: Constable and Co., Ltd., 1922.) 12s. 6d. net.\*

## Physics: Electrical Engineering

- Ainsley, F. J.** Mast and Aerial Construction for Amateurs; together with the Method of Erection and other Useful Information. Cr. 8vo. Pp. 82. (London: The Wireless Press, Ltd., New York: Wireless Press, Inc., 1922.) 1s. 6d.\*
- American Physical Society.** The Teaching of Physics, with Especial Reference to the Teaching of Physics to Students of Engineering: A Report by the Educational Committee of the American Physical Society. Med. 8vo. Pp. 55. (New York: American Physical Society, Columbia University, 1922.) 1 dollar.\*
- Born, M.** Der Aufbau der Materie: Drei Aufsätze über moderne Atomistik und Electronentheorie. Zweite, verbesserte Auflage. Demy 8vo. Pp. vi+86. (Berlin: J. Springer, 1922.) 3s.\*
- Born, M.** La Constitution de la matière. Traduit par H. Bellenot. (Collection de Monographies scientifiques étrangères, 2.) Sup. Roy. 8vo. Pp. iii+84. (Paris: A. Blanchard, 1922.) 6 francs.\*
- Bosch, M. ten.** Die Wärme-Übertragung: Auf Grund der neuesten Versuche für den praktischen Gebrauch zusammengestellt. (Berlin: J. Springer, 1922.) 240 marks.
- Chwolson, O. D.** Lehrbuch der Physik. Zweite verbesserte und vermehrte Auflage. Zweiter Band, zweite Abteilung: Die Lehre von der strahlenden Energie. Herausgegeben von G. Schmidt. Med. 8vo. Pp. xv+894. (Braunschweig: F. Vieweg und Sohn, 1922.) 80 marks.
- Cockaday, L. M.** Wireless Telephony for All: How to Construct and Maintain Modern Wireless Transmitting and Receiving Apparatus. Cr. 8vo. Pp. xii+209. (London: Herbert Jenkins, Ltd., 1922.) 5s. net.
- Coursey, P. R.** The Wireless Telephone: What it is, and How it Works. (Including Directions for Building a Simple Receiver for Wireless Telephone Broadcasts.) Cr. 8vo. Pp. vi+113. (London: The Wireless Press, Ltd.; New York: Wireless Press, Inc., 1922.) 2s. 6d.\*
- Crawley, C. G. C.** Wireless: Popular and Concise. Cr. 8vo. Pp. 92+8 plates. (London: Hutchinson and Co., 1922.) 1s. 6d. net.\*

- Crowther, J. A.** Molecular Physics. (Text-Books of Chemical Research and Engineering.) Third edition. Cr. 8vo. Pp. viii+189. (London: J. and A. Churchill, 1922.) 7s. 6d. net.\*
- Geisler, Dr.** Künstlicher Kautschuk für elektrische Isolierzwecke. (Heft 250 der Forschungsarbeiten auf dem Gebiete des Ingenieurwesens.) Pp. 89. (Berlin: Verlag des Vereins deutscher Ingenieure, 1922.)
- Gibson, A. H.** Edited by. Hydro-Electric Engineering. Vol. 2: Electrical. Roy. 8vo. Pp. viii+313. (London and Glasgow: Blackie and Son, Ltd., 1922.) 30s. net.\*
- Harris, P. W.** Crystal Receivers for Broadcast Reception. Cr. 8vo. Pp. 75. (London: The Wireless Press, Ltd.; New York: Wireless Press, Inc., 1922.) 1s. 6d.\*
- Hausmann, E.,** Edited by. Radio Phone Receiving: a Practical Book for Everybody. Cr. 8vo. Pp. viii+183+14 plates. (London, Bombay and Sydney: Constable and Co., Ltd., 1922.) 6s. net.\*
- Kaye, G. W. C.** The Practical Applications of X-rays. Demy 8vo. Pp. viii+135. (London: Chapman and Hall, Ltd., 1922.) 10s. 6d. net.\*
- Keen, R.** Direction and Position Finding by Wireless. Demy 8vo. Pp. xix+376. (London: The Wireless Press, Ltd.; New York: Wireless Press, Inc., 1922.) 9s.\*
- Kossel, W.** Les Forces de Valence et les Spectres de Röntgen: Deux mémoires sur la structure électronique de l'Atome. Traduit par M. Golay. (Collection de Monographies scientifiques étrangères, 3.) Sup. Roy. 8vo. Pp. iv+70. (Paris: A. Blanchard, 1922.) 4.50 francs.\*
- Marec, E.** La Force motrice électrique dans l'industrie. Roy. 8vo. Pp. viii+613. (Paris: Gauthier-Villars et Cie, 1922.) 55 francs.\*
- Mayer, P.** Einführung in die Mikroskopie. 2 verbesserte Auflage. Pp. 210. (Berlin: J. Springer, 1922.) 147 marks.
- Ministry of Munitions and Department of Scientific and Industrial Research.** Technical Records of Explosives Supply, 1915-1918. No. 9: Heat Transmission. Imp. 8vo. Pp. iv+48. (London: H.M. Stationery Office, 1922.) 5s. net.\*
- Mises, R. von.** Fluglehre: Vorträge über Theorie und Berechnung der Flugzeuge in elementarer Darstellung. Zweite durchgesehene Auflage. Pp. viii+210. (Berlin: J. Springer, 1922.) 300 marks.
- Morgan, A. P.** Wireless Telegraphy and Telephony: a Practical Treatise. Cr. 8vo. Pp. xvi+154. (London: Eveleigh Nash and Grayson, Ltd., 1922.) 6s. net.
- National Research Council.** Bulletin of the. Vol. 3, Part 3, No. 18: Theories of Magnetism. Report of the Committee on Theories of Magnetism of the National Research Council. By A. P. Wills, S. J. Barnett, L. R. Ingersoll, and others. Sup. Roy. 8vo. Pp. 261. (Washington: National Academy of Sciences, 1922.) 3 dollars.\*
- Painlevé, P.** Les Axiomes de la mécanique (examen critique): Note sur la propagation de la lumière. (Les Maîtres de la Pensée scientifique.) Cr. 8vo. Pp. xvii+112. (Paris: Gauthier-Villars et Cie, 1922.) 3 francs.\*
- Perry, F. W.** The Perry Auto-Time Morse System: an Aid to the Rapid Acquirement of Speed in the Transmission and Reception of the Morse Code. Cr. 8vo. Pp. 16. (London: The Wireless Press, Ltd.; New York: Wireless Press, Inc., 1922.) 6d.\*
- Ranger, R. H.** The Radio Pathfinder. Cr. 8vo. Pp. 155. (London: W. Heinemann, 1922.) 6s. net.
- Scott-Taggart, J.** Practical Wireless Valve Circuits. 8vo. Pp. 80. (London: Radio Press, Ltd., 1922.) 2s. 6d. net.
- Scott-Taggart, J.** Simplified Wireless. (Daily Express Series.) 8vo. Pp. 80. (London: Radio Press, Ltd., 1922.) 1s. net.
- Sleeper, M. B.** Wireless Design and Practice. Cr. 8vo. Pp. 246. (London: H. Frowde and Hodder and Stoughton, 1922.) 3s. 6d. net.
- Stokes, Sir G. G.** Mathematical and Physical Papers. Vol. 3. Reprint. 8vo. Pp. 415. (Cambridge: At the University Press, 1922.) 20s. net.
- Toché, C.** La Radiotéléphonie. Cr. 4to. Pp. vi+98. (Paris: Gauthier-Villars et Cie, 1922.) 10 francs.\*
- Watson, W. A.** Text-Book of Practical Physics. Third edition, revised by H. Moss. Ex. Cr. 8vo. Pp. xviii+635. (London: Longmans, Green and Co., 1922.) 12s. 6d. net.\*
- Whitehead, A. N.** The Principle of Relativity with Applications to Physical Science. Demy 8vo. Pp. xii+190. (Cambridge: At the University Press, 1922.) 10s. 6d. net.\*
- Winter, H.** Wärmelehre und Chemie für Kokerei- und Grubenbeamte. Pp. 209. (Berlin: J. Springer, 1922.) 288 marks.

## Chemistry

- Ascoli, A.** Die Thermopräzipitationsreaktion. Deutsche, verbesserte und vermehrte Ausgabe von R. S. Hoffmann. Pp. 124. (Wien und Leipzig: J. Sáfár, 1922.)
- Baly, E. C. G.** Inorganic Chemistry. (People's Books.) Revised edition. Pott 8vo. Pp. 125. (London: T. C. and E. C. Jack; T. Nelson and Sons, Ltd., 1922.) 1s. net.
- Bancroft, W. D.** First Report of the Committee on Contact Catalysis. (Reprint and Circular Series, No. 30.) Sup. Roy. 8vo. Pp. 43. (Washington: National Research Council, 1922.) 50 cents.\*
- Barrett, W. H.** Elementary Organic Chemistry. Cr. 8vo. Pp. 256. (Oxford: Clarendon Press; London: Oxford University Press, 1922.) 4s. 6d. net.\*
- Clark, W. M.** The Determination of Hydrogen Ions. Second edition, thoroughly revised and greatly enlarged. Pp. 480 and 2000 bibliographical references. (Baltimore, Md.: Williams and Wilkins Co., 1922.) 5 dollars.
- Clark, W. M.** Color Chart of Indicators. Reprinted from "The Determination of Hydrogen Ions." (Baltimore, Md.: Williams and Wilkins Co., 1922.) 1 dollar.
- Cross, C. F., and Doré, C.** Researches on Cellulose. IV. (1920-1921). (Vol. 4 of the Series "Cross and Bevan.") Cr. 8vo. Pp. x+253. (London: Longmans, Green and Co., 1922.) 15s. net.\*
- Galarza, R.** Química experimental. I: Mineral. Curso de química científica, con los principios recientes de la físico-química, para uso de las Escuelas Normales y Colegios Nacionales. Imp. 16mo. Pp. 128. (Córdoba: Angel Alvarez, 1922.)\*
- Gildemeister, E., and Hoffmann, Fr.** The Volatile Oils. Second edition by E. Gildemeister. Written under the Auspices of the firm of Schimmel and Co., Miltitz, near Leipzig. Authorised translation by E. Kremers. Third volume. Med. 8vo. Pp. xx+777. (London: Longmans, Green and Co., 1922.) 32s. net.\*
- Hackh, I. W. D.** Chemical Reactions and their Equations: a Guide and Reference Book for Students of Chemistry. Cr. 8vo. Pp. viii+138. (London: Chapman and Hall, Ltd., 1922.) 6s. net.\*
- Hammarsten, O.,** Herausgegeben von. Lehrbuch der physiologischen Chemie. Neunte, völlig ungearbeitete Auflage. Zwei Teile. Pp. viii+830. (München: J. F. Bergmann, 1922.) 2200 marks.
- Holmyard, E. J.** Inorganic Chemistry: a Textbook for Schools. Cr. 8vo. Pp. xi+560. (London: E. Arnold and Co., 1922.) 6s. 6d.\*
- Liesegang, R. E.,** Bearbeitet von. Kolloidchemie 1914-1922. (Wissenschaftliche Forschungsberichte. Naturwissenschaftliche Reihe, Band VI.) Pp. 100. (Dresden und Leipzig: T. Steinkopff, 1922.)
- Merck, E.** Prüfung der chemischen Reagenzien auf Reinheit. 3. Auflage. Pp. 378. (Darmstadt: E. Merck, 1922.)
- Olsen, J. C.,** Edited by. Van Nostrand's Chemical Annual. Fifth issue, 1922. Cr. 8vo. Pp. 900. (New York: D. Van Nostrand Co., 1922.) 4 dollars.
- Ostwald, W.** Grundriss der Kolloidchemie. 7. Auflage (unveränderter Abdruck der 6. Auflage). 1 Hälfte. Pp. 329. (Dresden und Leipzig: T. Steinkopff, 1922.) 160 marks.
- Partington, J. R., and Parker, L. H.** The Nitrogen Industry. Demy 8vo. Pp. xv+336. (London, Bombay and Sydney: Constable and Co., Ltd., 1922.) 21s. net.\*
- Platz, H.** Über Capillaranalyse und ihre Anwendung im pharmazeutischen Laboratorium. Pp. 42. (Leipzig: W. Schwabe, 1922.)

**Price, E. E.** Atomic Form: with Special Reference to the Configuration of the Carbon Atom. Gl. 8vo. Pp. iv + 140 + viii. (London: Longmans, Green and Co., 1922.) 5s. net.\*

**Smits, A.** The Theory of Allotropy. Translated from the German with the Author's sanction by J. S. Thomas. (Text-Books of Physical Chemistry.) Demy 8vo. Pp. xiii + 397. (London: Longmans, Green and Co., 1922.) 21s. net.\*

**Svedberg, T.** Die Methoden zur Herstellung kolloider Lösungen anorganischer Stoffe. 3. Auflage (unverändert Abdruck der 2. Auflage). Pp. 507 + 3 Tafeln. (Dresden und Leipzig: T. Steinkopff, 1922.) 240 marks.

**Tankard, A. R.** Chemistry in the Service of the Community. Demy 8vo. Pp. 19. (London: Benn Bros., Ltd., 1922.) 1s. net.\*

**Venable, F. P.** History of Chemistry. Cr. 8vo. Pp. vii + 169. (London and Sydney: D. C. Heath and Co., 1922.) 5s. net.\*

**West, C. J., and Gilman, H.** Organomagnesium Compounds in Synthetic Chemistry: a Bibliography of the Grignard Reaction, 1900-1921. (Reprint and Circular Series, No. 24.) Sup. Roy. 8vo. Pp. 103. (Washington: National Research Council, 1922.) 1.50 dollars.\*

## Technology

**Bagnall-Wild, R. K.,** and others. Aircraft Steels and Material. Med. 8vo. Pp. vii + 210. (London, Bombay and Sydney: Constable and Co., Ltd., 1922.) 16s. net.

**Belloni, A.** Manuel de l'ouvrier-fumiste en bâtiment. Pott 8vo. Pp. 400. (Paris: J.-B. Baillière et fils, 1922.) 10 francs.

**Bleibtreu, H.** Kohlenstaubfeuerungen. Bericht, dem Reichskohlenrat erstattet im Auftrage seines technisch-wirtschaftlichen Sachverständigen-Ausschusses für Brennstoffverwendung. (Berlin: J. Springer, 1922.) 300 marks.

**Bosc, A. du.** Le Camphre et sa synthèse; et **Trabut, L.** La Culture industrielle du camphrier. 8vo. Pp. 64 + 3 planches. (Lyon: P. Argençe, 1922.) 6 francs.

**Boswell, P. G. H.** A Comparison of British and American Foundry Practice, with special reference to the use of Refractory Sands. Demy 8vo. Pp. viii + 106. (Liverpool: University Press of Liverpool, Ltd.; London: Hodder and Stoughton, Ltd., 1922.) 4s. 6d. net.

**Braive, J.** Aide-mémoire de l'ingénieur-constructeur de béton armé. 3<sup>e</sup> édition. Ex. Cr. 8vo. Pp. xlii + 386. (Paris: Libr. Dunod, 1922.) 20 francs.

**Brock, A. St. H.** Pyrotechnics: The History and Art of Firework Making. Cr. 4to. Pp. xv + 197. (London: D. O'Connor, 1922.) 25s. net.

**Crabtree, J. H.** The Cotton Industry: from Raw Cotton to Woven Cloth. (Lockwood's Trade Manuals.) Cr. 8vo. Pp. 126. (London: C. Lockwood and Son, 1922.) 6s. net.

**Dolch, M.** Die rationelle Verwertung der niederwertigen Braunkohlen. (Sammlung Vieweg, Heft 63.) Pp. 80. (Braunschweig: F. Vieweg und Sohn, 1922.)

**Farnsworth, S.** Illumination, and its Development in the Present Day. Med. 8vo. Pp. 267. (London: Hutchinson and Co., 1922.) 24s. net.

**Fougnér, N. K.** Seagoing and other Concrete Ships. (Oxford Technical Publications.) Roy. 8vo. Pp. viii + 216. (London: H. Frowde and Hodder and Stoughton, 1922.) 21s. net.

**Fox, T. H.** The Mechanism of Weaving. Fifth edition. Cr. 8vo. Pp. xxii + 603. (London: Macmillan and Co., Ltd., 1922.) 12s. 6d. net.\*

**Guilvert, P.** Manuel du peintre en décors (filage-lettres). (Bibliothèque Professionnelle.) Pott 8vo. Pp. 232. (Paris: J.-B. Baillière et Fils, 1922.) 10 francs net.\*

**Herberg, G.** Handbuch der Feuerungstechnik und des Dampfkesselbetriebes mit einem Anhang über allgemeine Wärmetechnik. Dritte, verbesserte Auflage. (Berlin: J. Springer, 1922.) 480 marks.

**Illingworth, S. R.** Researches on the Constitution of Coal. Demy 8vo. Pp. 62. (London: The "Colliery Guardian" Co., Ltd., 1922.) 2s. 6d.

**Jaggard, W. R., and Drury, F. E.** Architectural Building Construction. (Cambridge Technical Series.) Vol. 2, Part 1. Demy 8vo. Pp. xviii + 387. (Cambridge: At the University Press, 1922.) 20s. net.

**Kerr, G. L.** Practical Coal-mining. (Griffin's Mining Series.) Eighth edition. Cr. 8vo. Pp. 789. (London: C. Griffin and Co., Ltd., 1922.) 16s. net.

**Liégeart, A.** Manuel du cordonnier: Technologie à l'usage des élèves des écoles pratiques, des cours professionnels et des apprentis. (Bibliothèque Professionnelle.) Pott 8vo. Pp. 298. (Paris: J.-B. Baillière et Fils, 1922.) 12 francs net.\*

**Mills, A. P.** Materials of Construction: Their Manufacture and Properties. Second edition, edited by H. W. Hayward. Med. 8vo. Pp. x + 404. (New York: J. Wiley and Sons, Inc.; London: Chapman and Hall, Ltd., 1922.) 20s. net.

**Mohs, K.** Neue Erkenntnis auf dem Gebiete der Müllerei und Bäckerei. 8vo. Pp. 68. (Dresden und Leipzig: T. Steinkopff, 1922.) 16 marks.

**Platt, W. H. H.** Aluminium Repairing. (Lockwood's Technical Manuals.) Cr. 8vo. Pp. 77. (London: C. Lockwood and Son, 1922.) 3s. net.

**Rousset, H.** Les Confitures. 2<sup>e</sup> édition, revue et augmentée. Fcap. 8vo. Pp. xii + 192. (Paris: Libr. Desforges, 1922.) 7.50 francs.

**Searle, A. B.** The Manufacture and Uses of Abrasive Materials. (Pitman's Technical Primers.) Pott 8vo. Pp. 127. (London: Sir I. Pitman and Sons, Ltd., 1922.) 2s. 6d. net.

**Sinnatt, F. S.** Coal and Allied Subjects: a Compendium of the First Ten Bulletins issued by the Lancashire and Cheshire Coal Research Association. Cr. 8vo. Pp. v + 205. (London: H. F. and G. Witherby, 1922.) 15s. net.\*

**University of Sheffield:** Department of Fuel Technology. Coal: a Series of Lectures on Coal and its Utilisation, by H. Chamberlain, J. W. Cobb, R. Lessing, F. S. Sinnatt, and M. C. Stopes. Med. 4to. Pp. iii + 41. (London: The "Colliery Guardian" Co., Ltd., 1922.) 5s.\*

**Vincent, M.** Manuel du mouleur. Construction des modèles de fonderie et dispositions de moulage. Pott 8vo. Pp. 334. (Paris: J.-B. Baillière et fils, 1922.) 12 francs.

**Wright, T.** The Romance of the Shoe: being the History of Shoemaking in all Ages, and especially in England and Scotland. Demy 8vo. Pp. xvi + 317. (London: C. J. Farncombe and Sons, Ltd., 1922.) 12s. 6d. net.

## Astronomy

**Dyson, Sir F. W.,** Under the Direction of. Astronomical and Magnetical and Meteorological Observations made at the Royal Observatory, Greenwich, in the year 1917. Roy. 4to. Pp. 8 + Axx + A54 + B21 + C3 + Dxiv + D163 + 7 + Exxii + E78 + 4 plates. (London: H.M. Stationery Office, 1922.) 50s. net.\*

**Frischauf, J.** Grundriss der theoretischen Astronomie und der Geschichte der Planetentheorien. Dritte vermehrte Auflage. Med. 8vo. Pp. xvi + 248. (Leipzig: W. Engelmann, 1922.) 270 marks.\*

**Gill, Sir D.,** Under the Direction of. Cape Astrographic Zones. Vol. 5: Catalogue of Rectangular Coordinates and Diameters of Star-Images derived from Photographs taken at the Royal Observatory, Cape of Good Hope. Completed and prepared for Press under the Supervision of S. S. Hough. Zone -45°. Roy. 4to. Pp. xxxvii + 596. (London: H.M. Stationery Office, 1922.) 50s. net.\*

**Gyllenberg, W.** Meridianbeobachtungen von 391 hauptsächlich farbigen Sternen. (Meddelanden från Lunds Astronomiska Observatorium, Serie 2, Nr. 27.) Demy 4to. Pp. 21. (Lund: C. W. K. Gleerup; Leipzig: O. Harrassowitz, 1922.)\*

**Hawks, E.** Astronomy. (Romance of Reality Series.) 8vo. Pp. 295. (London: T. C. and E. C. Jack; T. Nelson and Sons, Ltd., 1922.) 6s. net.

**Hough, S. S.,** Under the Direction of. Annals of the Cape Observatory. Vol. xi: Southern Circumpolar Researches. Part 4: Discussion of a Series of Meridian Observations of Circumpolar Stars made with the

Reversible Transit-Circle during the Year 1917. Roy. 4to. Pp. 315-350. 4s. net. Part 5: Ephemerides of 99 Southern Circumpolar Stars, derived from Observations 1830-1917. Prepared at the Cape by R. T. Pett. Pp. 351-412. 12s. 6d. net. (London: H.M. Stationery Office, 1922.)\*

Raab, S. A Research on Open Clusters. (Meddelanden från Lunds Astronomiska Observatorium, Serie 2, Nr. 28.) Demy 4to. Pp. 94+26 plates. (Lund: Scientia, 1922.)\*

## Meteorology

**Air Ministry:** Meteorological Office. Supplement No. 1 to Particulars of Meteorological Reports issued by Wireless Telegraphy in Great Britain and the Countries of Europe and North Africa. (Containing Amendments based on Information available up to 31st July 1922.) (M.O. 252.) Roy. 8vo. Pp. 12. (London: H.M. Stationery Office, 1922.) 6d. net.\*

**Air Ministry:** Meteorological Office. Forecast Code for the Abbreviation of Weather Forecasts transmitted by Telegraphy or Radiotelegraphy. (M.O. 244.) Roy. 8vo. Pp. 18. (London: H.M. Stationery Office, 1921.) 1s. net.\*

**Air Ministry:** Meteorological Office. British Meteorological and Magnetic Year-Book, 1920. Part 3, Section 2: Geophysical Journal, 1920, comprising Daily Values of the Meteorological and Geophysical Elements at Three Observatories of the Meteorological Office; Daily Values of Solar Radiation at South Kensington; Wind Components at Fixed Hours at Four Anemograph Stations; Tabulations of Occasional Soundings of the Upper Air; and Results of Observations of Cloud and Aurora; together with an Annual Supplement. (M.O. 238d.) Roy. 4to. Pp. xi+108. (London: H.M. Stationery Office, 1922.) 25s. net.\*

**Air Ministry:** Meteorological Office. Weather Forecasting in the Eastern North Atlantic and Home Waters for Seamen. By Comdr. L. A. Brooke Smith. (M.O. 216.) Roy. 8vo. Pp. 23. (London: H.M. Stationery Office, 1921.) 6d. net.\*

**Air Ministry:** Meteorological Office, London. A Short Course in Elementary Meteorology. By W. H. Pick. (M.O. 247.) Roy. 8vo. Pp. 118. (London: H.M. Stationery Office, 1921.) 1s. 6d. net.\*

**Air Ministry:** Meteorological Office. The Weather Map. Fifth issue (reprint of Fourth). An Introduction to Modern Meteorology. By Sir Napier Shaw. (M.O. 225i.) Roy. 16mo. Pp. 109+8 plates+8 charts. (London: H.M. Stationery Office, 1921.) 1s. 3d. net.\*

**Air Ministry:** Meteorological Office. The Observer's Handbook. Approved for the Use of Meteorological Observers by the Meteorological Office and the Royal Meteorological Society. 1921 edition. (M.O. 191.) Roy. 8vo. Pp. xxx+140+18 plates+10+17 plates+5. (London: H.M. Stationery Office, 1921.) 7s. 6d. net.\*

**Air Ministry:** Meteorological Office. Notes on Meteorological Corrections for the Use of Gunners. (M.O. 241.) Roy. 8vo. Pp. 17. (London: H.M. Stationery Office, 1921.) 3d. net.\*

**Air Ministry:** Meteorological Office. Cloud Forms according to the International Classification: The Definitions and Descriptions approved by the International Meteorological Committee in 1910; with an Atlas of Photographs of Clouds selected from the Collection of Mr. G. A. Clarke, of the Observatory, Aberdeen. (M.O. 233, second edition.) Roy. 8vo. Pp. 10+17 plates+5. (London: H.M. Stationery Office, 1921.) 1s. 6d. net.\*

**Air Ministry:** Meteorological Office. The New International Code for Meteorological Messages. (M.O. 253; Extract from M.O. 252.) Roy. 8vo. Pp. 65-84. (London: H.M. Stationery Office, 1922.) 4d. net.\*

**Board of Education.** Catalogue of the Collections in the Science Museum, South Kensington, with Descriptive and Historical Notes and Illustrations: Meteorology. Roy. 8vo. Pp. 107+6 plates. (London: H.M. Stationery Office, 1922.) 1s. 6d. net.\*

Drosne, P. Le beau, le mauvais temps et la relativité. Gl 8vo. Pp. 68. (Paris: G. Doin, 1922.) 3-50 francs.\*

Ekardt, W. R. Grundzüge einer Physioklimatologie des Festländer. Roy. 8vo. Pp. v+123. (Berlin: Gebrüder Borntraeger, 1922.) 4s. 6d.\*

Huntington, E., and Vishner, S. S. Climatic Changes: their Nature and Causes. Med. 8vo. Pp. xvi+329. (New Haven: Yale University Press; London: Oxford University Press, 1922.) 17s. 6d. net.\*

## Mineralogy

**Department of Scientific and Industrial Research.** Report of the Tin and Tungsten Research Board. Roy. 8vo. Pp. vi+100. (London: H.M. Stationery Office, 1922.) 3s. 6d. net.\*

Wybergh, W. J. The Coal Resources of Union of South Africa. Vol. 1: The Coalfields of Witbank, Springs, and Heidelberg, and of the Orange Free State. (Department of Mines and Industries: Geological Survey. Memoir No. 19.) Med. 8vo. Pp. 134+15 plates. (Pretoria: Government Printing and Stationery Office, 1922.) 10s.\*

## Geology

Arlt, T. Handbuch der Palaeogeographie. Band 1: Palaeaktologie. Band 2: Palaeogeographie. 2 Bände. Pp. xxii+1648. (Berlin: Gebrüder Borntraeger, 1922.) 1320 marks.

Coleman, A. P., and Parks, W. A. Elementary Geology: with special reference to Canada. Demy 8vo. Pp. xx+363. (London and Toronto: J. M. Dent and Sons, Ltd., 1922.) 15s. net.\*

Cotton, C. A. Geomorphology of New Zealand. Part 1. Systematic: An Introduction to the Study of Landforms. (New Zealand Board of Science and Art: Manual No. 3.) Demy 8vo. Pp. 450. (Wellington, N.Z.: Dominion Museum, 1922.) Paper, 18s.; cloth, 22s. 6d.\*

Dacqué, E. Geologie. I Teil: Allgemeine Geologie. (Sammlung Goschen, 13.) Zweite, verbesserte Auflage. Pott 8vo. Pp. 128. (Berlin und Leipzig: W. de Gruyter und Co., 1922.) 1s. 6d.\*

Waguet, P. Géologie agricole pratique. 8vo. Pp. 20+1 planche. (Beauvais: Libr. Prévot, 1922.)

## Geography: Travel

Arbos, P. La Vie pastorale dans les Alpes françaises: Étude de géographie humaine. 8vo. Pp. 720+16 planches. (Paris: A. Colin, 1922.) 28 francs.

Barker, W. H. The British Isles: a Descriptive Account on a Regional Basis. (The "Modern Outlook" Geographies, Book 1.) Large Cr. 8vo. Pp. 140. (London: "Geographia" Ltd., 1922.) 2s. 6d.

Bechhofer, C. E. A Wanderer's Log: Being some Memories of Travel in India, the Far East, Russia, the Mediterranean, and elsewhere. Med. 8vo. Pp. 246. (London: Mills and Boon, Ltd., 1922.) 8s. 6d. net.

Blackman, J. E. An Outline of the Geography of the West Indies. Cr. 8vo. Pp. 124. (Oxford: B. Blackwell, 1922.) 3s. 6d. net.

Böhnecke, G. Salzgehalt und Strömungen der Nordsee. (Veröffentlichungen des Instituts für Meereskunde. Neue Folge. A: Geographisch-naturwissenschaftliche Reihe. Heft 10.) Sup. Roy. 8vo. Pp. 34. (Berlin: E. S. Mittler und Sohn, 1922.)\*

Bosworth, G. F. A Geography of America. Ex. Cr. 8vo. Pp. v+376-471. (Cambridge: At the University Press, 1922.) 1s. 8d.

Bosworth, G. F. A Geography of Asia. Ex. Cr. 8vo. Pp. iv+209-280. (Cambridge: At the University Press, 1922.) 1s. 6d.

Bosworth, G. F. A Geography of Africa. Ex. Cr. 8vo. Pp. v+277-338. (Cambridge: At the University Press, 1922.) 1s. 6d.

Bosworth, G. F. A Geography of Australasia. Ex. Cr. 8vo. Pp. iv+336-377. (Cambridge: At the University Press, 1922.) 1s. 3d.

Bosworth, G. F. A Geography of Europe (excluding the British Isles). Ex. Cr. 8vo. Pp. iv+117-215. (Cambridge: At the University Press, 1922.) 1s. 8d.

**Braun, F.** Die Urbbevölkerung Europas und die Herkunft der Germanen. Pp. 91. (Berlin, Stuttgart und Leipzig: W. Kohlhammer, 1922.) 22 marks.

**Cornish, J. B., and Bridger, J. A. D.,** Edited by. Penzance and the Land's End district: a Handbook for Visitors and Residents. (Homeland Handbooks.) Cr. 8vo. Pp. 104. (London: Homeland Association, 1922.) 1s. 6d. net.

**Cresswell, B. F.** Bideford: a Handbook for Visitors and Residents. (Homeland Handbooks.) Eighth edition. Cr. 8vo. Pp. 66. (London: Homeland Association, 1922.) 1s. 6d. net.

**Geddie, J.,** Described by. The Shores of Fife. Painted by E. W. Haslehurst. 4to. Pp. 68. (London and Glasgow: Blackie and Son, Ltd., 1922.) 3s. net.

**Grenfell, W. T.,** and others. Labrador: The Country and the People. New edition, revised, and with a new introduction. Cr. 8vo. Pp. xxvi+529. (New York: The Macmillan Co.; London: Macmillan and Co., Ltd., 1922.) 10s. net.

**Hewitt, W.** The Wirral Peninsula: an Outline Regional Survey. Cr. 8vo. Pp. x+299. (Liverpool: University Press of Liverpool, Ltd.; London: Hodder and Stoughton, Ltd., 1922.) 7s. 6d. net.\*

**Hills, J. W., and Dunbar, I.** The Golden River: Sport and Travel in Paraguay. Med. 8vo. Pp. vi+187. (London: Philip Allan and Co., 1922.) 10s. 6d. net.

**Huntington, E., and Williams, F. E.** Business Geography. With the Coöperation of R. M. Brown and L. E. Chase. Demy 8vo. Pp. x+482. (New York: J. Wiley and Sons, Inc.; London: Chapman and Hall, Ltd., 1922.) 13s. 6d. net.\*

**Joerg, W. L. G.** Recent Geographical Work in Europe. (Reprint and Circular Series, No. 37.) Sup. Roy. 8vo. Pp. 431-484. (Washington: National Research Council, 1922.) 50 cents.\*

**Luke, H. C., and Keith-Roach, E.,** Edited by. The Handbook of Palestine. (Issued under the authority of the Government of Palestine.) Gl. 8vo. Pp. xii+295. (London: Macmillan and Co., Ltd., 1922.) 12s. net.\*

**Page, J. W.** An Elementary Geography of the World, Regional and Economic. With numerous Practical Exercises. Gl. 8vo. Part I: Africa. Pp. 64. 8d. net. Part 2: Australasia. Pp. 65-108. 8d. net. Part 3: America. Pp. 109-184. 8d. net. Part 4: Asia. Pp. 185-248. 9d. net. Part 5: Europe. Pp. 249-332. 9d. net. Part 6: British Islands. Pp. 333-416. 9d. net. (London: Macdonald and Evans, 1922.)

**Parkinson, T. W. F.** Asia: Monsoon Lands. ("Reason Why" Geography.) Revised edition. 8vo. Pp. 256. (London: W. Collins, Sons and Co., Ltd., 1922.) 3s.

**Parkinson, T. W. F.** The British Isles. ("Reason Why" Geography.) 8vo. Pp. 256. (London: W. Collins, Sons and Co., Ltd., 1922.) 3s.

**Parkinson, T. W. F.** The Empire Beyond the Seas. ("Reason Why" Geography.) 8vo. Pp. 271. (London: W. Collins, Sons and Co., Ltd., 1922.) 3s.

**Parkinson, T. W. F.** England and Wales. ("Reason Why" Geography.) 8vo. Pp. 204. (London: W. Collins, Sons and Co., Ltd., 1922.) 2s. 6d.

**Parkinson, T. W. F.** Europe. ("Reason Why" Geography.) 8vo. Pp. 220. (London: W. Collins, Sons and Co., Ltd., 1922.) 2s. 9d.

**Parkinson, T. W. F.** Round the World. ("Reason Why" Geography.) 8vo. Pp. 176. (London: W. Collins, Sons and Co., Ltd., 1922.) 2s. 3d.

**Parkinson, T. W. F.** The World. ("Reason Why" Geography.) 8vo. Pp. 256. (London: W. Collins, Sons and Co., Ltd., 1922.) 3s.

**Peixotto, E.** Through Spain and Portugal. Med. 8vo. Pp. 296. (London: C. Scribner's Sons, 1922.) 16s. net.

**Ponting, H. G.** In Lotus-Land: Japan. Cr. 4to. Pp. xii+306. (London and Toronto: J. M. Dent and Sons, Ltd., 1922.) 18s. net.

**Pringleau, J.** The Adventures of Imshi: a Two-seater in Search of the Sun. Med. 8vo. Pp. 358. (London: Jarrolds, Ltd., 1922.) 21s. net.

**Ragg, L. M.** Things Seen on the Italian Lakes. Demy 16mo. Pp. viii+150. (London: Seeley, Service and Co., Ltd., 1922.) 3s. 6d. net.

**Rostock, X.** Copenhagen: The Capital of Denmark and its Environs. Handbook for Tourists. Gl. 8vo. Pp. 89. (Copenhagen: G. E. C. Gad, 1922.)

**Rouch, J.** Manuel d'océanographie physique. Demy 8vo. Pp. 229. (Paris: Masson et Cie, 1922.) 15 francs.\*

**Schiffmann, K.** Das Land ob der Enns, eine alpbairische Landschaft in den Namen ihrer Siedlungen, Berge, Flüsse und Seen. Pp. xii+248. (München: R. Oldenbourg, 1922.) 68 marks.

**Shackleton, Sir E.** South: the Story of Shackleton's 1914-1917 Expedition. New and revised edition. Cr. 8vo. Pp. xv+205+32 plates. (London: W. Heinemann, 1922.) 5s. net.

**Shepherd, C. K.** Across America by Motor-cycle. Med. 8vo. Pp. 260. (London: E. Arnold and Co., 1922.) 12s. 6d. net.

**Sherwood, F. A.** Glimpses of South America. Roy. 8vo. Pp. 416. (London: Leonard Parsons, Ltd., 1922.) 18s. net.

**Smith, C. E.** From the Deep of the Sea: Being the Diary of the late Charles Edward Smith. Edited by his son, C. E. Smith Harris. Med. 8vo. Pp. xii+288. (London: A. and C. Black, Ltd., 1922.) 10s. 6d. net.

**Speakman, H.** Beyond Shanghai. Demy 8vo. Pp. 198. (London: T. Werner Laurie, Ltd., 1922.) 16s. net.

**Waldo, F. L.** With Grenfell on the Labrador. Ex. Cr. 8vo. Pp. 189. (London: Oliphants, Ltd., 1922.) 6s. net.

**Ward, E. M.** English Coastal Evolution. Cr. 8vo. Pp. xii+262+14 plates. (London: Methuen and Co., Ltd., 1922.) 8s. 6d. net.\*

## Biology: Natural History

**Berridge, W. S.** Wonders of Animal Life. New and cheaper edition. Cr. 8vo. Pp. 270. (London: Simpkin, Marshall and Co., Ltd., 1922.) 5s. net.

**Berridge, W. S.** Animal Curiosities. Med. 8vo. Pp. 252. (London: Thornton Butterworth, Ltd., 1922.) 7s. 6d. net.

**Bird Sanctuaries in Royal Parks:** Report of the Committee appointed by the Earl of Crawford and Balcarres to consider the establishment of Bird Sanctuaries in the Royal Parks. Demy 8vo. Pp. 10. (London: H.M. Stationery Office, 1922.) 6d. net.\*

**Curtis, W. C.** Science and Human Affairs: from the Viewpoint of Biology. Med. 8vo. Pp. vii+330. (London: G. Bell and Sons, Ltd., 1922.) 15s. net.\*

**Deegener, P.** Ein Lehrjahr in der Natur. Anregungen zu biologischen Spaziergängen für Wanderer und Naturfreunde. 2 Teile. (Jena: G. Fischer, 1922.) Teil I: 280 marks. Teil II: 320 marks.

**Duncan, F. M.** Animals of the Sea. (Romance of Reality Series.) Ex. Cr. 8vo. Pp. vii+292. (London: T. C. and E. C. Jack; T. Nelson and Sons, Ltd., 1922.) 6s. net.

**Ewald, C.** The Pond. Translated from the Danish by A. Teixeira de Mattos. Pott 4to. Pp. 127. (London: Thornton Butterworth, Ltd., 1922.) 6s. net.

**Fonks, H.** The Trail of the Elk. From the Norwegian. Ex. Cr. 8vo. Pp. 218. (London: Jonathan Cape, 1922.) 6s. net.

**Kearton, R.** At Home with Wild Nature. Ex. Cr. 8vo. Pp. xii+164+plates. (London: Cassell and Co., Ltd., 1922.) 7s. 6d. net.\*

**Kindermann, H.** Lola: or the Thought and Speech of Animals. Translated by Agnes Blake; with a Chapter on Thinking Animals by W. Mackenzie. Cr. 8vo. Pp. ix+188. (London: Methuen and Co., Ltd., 1922.) 6s. net.\*

**Kirkman, F. B.** British Birds. (People's Books.) Third edition, revised and reset. Pott 8vo. Pp. 140. (London: T. C. and E. C. Jack; T. Nelson and Sons, Ltd., 1922.) 1s. net.

**Leach, J. A.** Australian Nature Studies: a Book of Reference for those interested in Nature-Study. Demy 8vo. Pp. viii+501. (Melbourne: Critchley Parker, 1922.) 13s. 9d.\*

- Long, W. J.** How Animals Talk, and other pleasant Studies of Birds and Beasts. Cr. 8vo. Pp. 302. (London: Harper and Bros., 1922.) 6s. net.
- Massingham, H. J.** Poems about Birds: From the Middle Ages to the Present Day. Cr. 8vo. Pp. 415. (London: T. Fisher Unwin, 1922.) 10s. 6d. net.\*
- Mills, E. A.** Watched by Wild Animals. Demy 8vo. Pp. 351. (London: Eveleigh Nash and Grayson, Ltd., 1922.) 7s. 6d. net.
- Nüsslin, O.** Forstinssektenkunde. Dritte, neubearbeitete und vermehrte Auflage, herausgegeben von L. Rhumbler. Pp. xvi+568. (Berlin: P. Parey, 1922.) 120 marks.
- Pycraft, W. P.** Birds in Flight. Cr. 4to. Pp. x+133. (London: Gay and Hancock, Ltd., 1922.) 15s. net.
- Schoenichen, W.** Herausgegeben von. Der biologische Lehrausflug: Ein Handbuch für Studierende und Lehrer aller Schulgattungen. (Jena: G. Fischer, 1922.) 480 marks.
- Thompson, J. M.** Wild Kindred. Ex. Cr. 8vo. Pp. 251. (London: Jonathan Cape, 1922.) 6s. net.
- Thompson, J. M.** Forest Dwellers. Ex. Cr. 8vo. Pp. 252. (London: Jonathan Cape, 1922.) 6s. net.
- Thompson, J. M.** Wings and Pads. Ex. Cr. 8vo. Pp. 251. (London: Jonathan Cape, 1922.) 6s. net.
- Titschack, E.** Beiträge zu einer Monographie der Kleidermotte, *Tineola biselliella*. Sup. Roy. 8vo. Pp. 168+4 Tafeln. (Leipzig: Gebrüder Borntraeger, 1922.) 225 marks.
- ### Botany: Horticulture: Forestry
- Armstrong, D.** Winter Flowers: And how to Obtain Them. ("Country Life" Booklets.) Gl. 8vo. Pp. 32. (London: "Country Life"; G. Newnes, Ltd., 1922.) 9d. net.
- Berndl, R.** Das Pflanzenleben des Hochgebirges. Pp. vii+179. (Leipzig: Quelle und Meyer, 1922.) 26 marks.
- Britton, N. L., and Rose, J. N.** The Cactaceae: Descriptions and Illustrations of Plants of the Cactus Family. Vol. 3. (Publication 248.) Med. 4to. Pp. vii+255+24 plates. (Washington: Carnegie Institution, 1922.) \*
- Fritsch, K.** Exkursionsflora für Österreich und die ehemals österreichischen Nachbargebiete. 3. Auflage. Pp. lxxx+824. (Wien: C. Gerold, 1922.) 200 marks.
- Gilbert-Carter, H.** Guide to the University Botanic Garden, Cambridge. Cr. 8vo. Pp. xvi+117+24 plates. (Cambridge: At the University Press, 1922.) 3s. 6d. net.\*
- Guignard, L.** Le Jardin botanique de la Faculté de Pharmacie de Paris, avec un plan du jardin. Fcap. 8vo. Pp. 180. (Toulouse: Libr. Marquette, 1922.) 8 francs.
- Karsten, G., and Schenck, H.,** Herausgegeben von. Vegetationsbilder. 14 Reihe, Heft 5/6: Vegetationsbilder aus der Sierra de Mixteca, Mexiko. Von H. Schenck. 480 marks. 14 Reihe, Heft 7: Vegetationsbilder aus Kalifornien. Von J. C. T. Uphof. 240 marks. (Jena: G. Fischer, 1922.)
- Kolkwitz, R.** Pflanzenphysiologie: Versuche und Beobachtungen an höheren und niederen Pflanzen. 2 umgearbeitete Auflage. Pp. 304+12 Tafeln. (Jena: G. Fischer, 1922.) 130 marks.
- Linsbauer, K.,** Herausgegeben von. Handbuch der Pflanzenanatomie. II Abteilung, 1 Teil: Thalloyphyten. Band 6: Bakterien und Strahlenpilze. Von R. Lieske. Cr. 4to. Pp. iv+88. (Berlin: Gebrüder Borntraeger, 1922.) 4s. 6d.\*
- Lowson's Text Book of Botany** (Indian edition). Revised and adapted by B. Sahni and M. Willis. Third edition. Cr. 8vo. Pp. xii+640. (London: University Tutorial Press, Ltd., 1922.) 9s. 6d.\*
- Maiden, J. H.** A Critical Revision of the Genus *Eucalyptus*. Med. 4to. Vol. 6, Part 6 (Part 56 of the Complete Work). Pp. iv+255+340+plates 228-231. (Sydney: J. Spence, 1922.) 3s. 6d.\*
- Meniaud, J.** La forêt de la Côte d'Ivoire et son exploitation. 4to. Pp. xii+130+28 planches. (Paris: Publications africaines, 1922.)
- Methuen, A.,** Arranged by. An Alpine A B C and List of Easy Rock Plants. Pott 8vo. Pp. x+35. (London: Methuen and Co., Ltd., 1922.) 1s. 6d. net.\*
- Oltmanns, F.** Morphologie und Biologie der Algen. 2. Auflage. I Band: Chrysophyceae, Chlorophyceae, Pp. vi+459. (Jena: G. Fischer, 1922.) 100 marks.
- Putterill, V. A.** The Biology of *Schizosphyllum commune* Fries, with special reference to its Parasitism. (Department of Agriculture: Science Bulletin No. 25.) Med. 8vo. Pp. 35+5 plates. (Pretoria: Government Printing and Stationery Office, 1922.) 3d.\*
- Rohde, E. S.** The Old English Herbals. Cr. 4to. Pp. xii+243. (London: Longmans, Green and Co., 1922.) 21s. net.\*
- Woodward, K. W.** The Valuation of American Timberlands. Med. 8vo. Pp. vii+246. (New York: J. Wiley and Sons, Inc.; London: Chapman and Hall, Ltd., 1922.) 15s. net.\*
- Woolsey, Jr., T. S.** American Forest Regulation. Med. 8vo. Pp. xv+217. (London: Chapman and Hall, Ltd., 1922.) 18s. net.\*
- Wright, H. J., and Wright, W. P.** Beautiful Flowers, and How to Grow Them. Roy. 8vo. Pp. vii+402. (London: T. C. and E. C. Jack; T. Nelson and Sons, Ltd., 1922.) 10s. 6d. net.
- ### Zoology
- Australasian Antarctic Expedition, 1911-1914.** Scientific Reports. Series C: Zoology and Botany. Vol. 6, Part 4: Oligochaeta of Macquarie Island. By W. B. Benham. Pp. 38. 3s. Vol. 6, Part 5: Gephyrea Inermia. By W. B. Benham. Pp. 22+1 plate. 2s. (Sydney: J. Spence, 1922.) \*
- Australasian Antarctic Expedition, 1911-1914.** Scientific Reports. Series C: Zoology and Botany. Vol. 8, Part 2: Echinodermata Ophiuroidea. By René Köhler. Pp. 98+plates 76-90. (Sydney: J. Spence, 1922.) 10s. 8d.\*
- Bartsch, P.** A Monograph of the American Shipworms (Smithsonian Institution: United States National Museum, Bulletin 122.) Roy. 8vo. Pp. 51+37 plates. (Washington: Government Printing Office, 1922.) 30 cents.\*
- Chittenden, F. H., and Fink, D. E.** The Green June Beetle. (U.S. Department of Agriculture, Bulletin No. 891, Professional Paper.) Med. 8vo. Pp. 52+10 plates. (Washington: Government Printing Office, 1922.) \*
- Chopard, L.** Faune de France. 3: Orthoptères et Dermoptères. Roy. 8vo. Pp. vi+212. (Paris: P. Lechevalier, 1922.) 18 francs.\*
- Cuénot, L.** Faune de France. 4: Sipunculien, Échiuriens, Priapulien. Roy. 8vo. Pp. 31. (Paris: P. Lechevalier, 1922.) 3 francs.\*
- Hadwen, S., and Paimer, L. J.** Reindeer in Alaska. (U.S. Department of Agriculture, Bulletin No. 1089.) Med. 8vo. Pp. 74+24 plates. (Washington: Government Printing Office, 1922.) 25 cents.\*
- Komai, T.** Studies on Two Aberrant Ctenophores, *Cœloplana* and *Gradostes*. Cr. 4to. Pp. 102+9 plates. (Kyoto: The Author, College of Science, Imperial University, 1922.) \*
- MacBride, E. W.** Zoology: the Study of Animal Life. (People's Books.) Revised edition. Pott 8vo. Pp. 127. (London: T. C. and E. C. Jack; T. Nelson and Sons, Ltd., 1922.) 1s. net.
- ### Agriculture
- Foster, W. A., and Carter, D. G.** Farm Buildings. (Agricultural Engineering Series.) Ex. Cr. 8vo. Pp. xv+377. (New York: J. Wiley and Sons, Inc.; London: Chapman and Hall, Ltd., 1922.) 15s. net.\*
- Hatton, R. G., and Elgar, W. R.** Practical Fruit Farming. (Royal Agricultural Society of England.) 8vo. Pp. 87. (London: J. Murray, 1922.) 2s. net.
- McCconnell, P.** Notebook of Agricultural Facts and Figures for Farmers and Farm Students. Tenth edition, revised and enlarged. Pott 8vo. Pp. 547. (London: C. Lockwood and Son, 1922.) 15s. net.

## Anatomy: Physiology

**Aberhalden, E.** Physiologisches Praktikum: Chemische, physikalisch-chemische, physikalische und physiologische Methoden. Dritte, neubearbeitete und vermehrte Auflage. (Berlin: J. Springer, 1922.) 1210 marks.

**Anthony, R.** Archives de morphologie générale et expérimentale. Fascicule 14 (Morphologie expérimentale): Le déterminisme et l'adaptation morphologiques en biologie animale. Première partie: Déterminisme morphologique et morphogénie. Sup. Roy. 8vo. Pp. 374. (Paris: G. Doin, 1922.) 28 francs.\*

**Curzon-Miller, A. G.** Physiology for Dental Students. Med. 8vo. Pp. viii+206. (London: E. Arnold and Co., 1922.) 10s. 6d. net.

**Hoffmann, H.** Die individuelle Entwicklungskurve des Menschen: Ein Problem der medizinischen Konstitutions- und Vererbungslehre. (Berlin: J. Springer, 1922.) 192 marks.

**Hoffmann, P.** Untersuchungen über die Eigenreflexe (Sehnenreflexe) menschlicher Muskeln. Pp. iv+106. (Berlin: J. Springer, 1922.) 308 marks.

**MacLeod, J. J. R.,** assisted by Pearce, R. G., Redfield, A. C., Taylor, N. B., and by others. Physiology and Biochemistry in Modern Medicine. Fourth edition. Roy. 8vo. Pp. xxxii+992. (London: H. Kimpton, 1922.) 42s. net.\*

**Mangenor, G.** Archives de morphologie générale et expérimentale. Fascicule 9 (Histologie): Recherches sur les constituants morphologiques du cytoplasma des algues. Sup. Roy. 8vo. Pp. ix+330+16 planches. (Paris: G. Doin, 1922.) 30 francs.\*

**Policard, A.** Précis d'histologie physiologique. (Collection Testut.) Pott 8vo. Pp. 1130. (Paris: G. Doin, 1922.) 40 francs.

**Pritchard, E.** The Physiological Feeding of Infants and Children. Fourth edition, revised. Roy. 8vo. Pp. 500. (London: H. Kimpton, 1922.) 21s. net.

**Raiment, P. C., and Peskett, G. L.** A Laboratory Handbook of Bio-Chemistry. Cr. 8vo. Pp. 102. (London: E. Arnold and Co., 1922.) 5s. net.\*

**Stefanelli, A.** I microscopici dispositivi periferici dei nervi. (Sezione Scientifica Sonzogno, N. 2.) Pp. 114. (Milano: Casa Editrice Sonzogno, 1922.) 4 lire.

**Taylor, W. W.** Practical Chemical Physiology. Cr. 8vo. Pp. 71. (London: E. Arnold and Co., 1922.) 5s. net.\*

**Verworn, M.** Allgemeine Physiologie: Ein Grundriss der Lehre vom Leben. Siebente, neubearbeitete Auflage, herausgegeben von F. W. Fröhlich. (Jena: G. Fischer, 1922.) 960 marks.

## Anthropology: Ethnology

**Densmore, F.** Northern Ute Music. (Smithsonian Institution: Bureau of American Ethnology, Bulletin 75.) Med. 8vo. Pp. 213+16 plates. (Washington: Government Printing Office, 1922.)\*

**Fleming, R. M.** Stories from the Early World. Med. 8vo. Pp. 156+12 plates. (London: Benn Bros., Ltd., 1922.) 15s. net.\*

**Frazier, Sir J. G.** The Golden Bough: a Study in Magic and Religion. Abridged edition. Demy 8vo. Pp. xiv+756. (London: Macmillan and Co., Ltd., 1922.) 18s. net.\*

**McGovern, J. B. M.** Among the Head-Hunters of Formosa. Demy 8vo. Pp. 220. (London: T. Fisher Unwin, 1922.) 15s. net.\*

**Melville, H.** Typee: A Peep at Polynesian Life during a Four Months' Residence in a Valley of the Marquesas, with notices of the French Occupation of Tahiti, and the Provisional Cession of the Sandwich Islands to Lord Paulet, and a Sequel, The Story of Toby. Med. 8vo. Pp. xvii+366. (London, Bombay and Sydney: Constable and Co., Ltd., 1922.) 17s. 6d. net.

**Melville, H.** Omoo: a Narrative of Adventures in the South Seas. Med. 8vo. Pp. xiv+371. (London, Bombay and Sydney: Constable and Co., Ltd., 1922.) 17s. 6d. net.

**Swanton, J. R.** Early History of the Creek Indians and their Neighbors. (Smithsonian Institution: Bureau of American Ethnology, Bulletin 73.) Med. 8vo. Pp. 492+10 plates. (Washington: Government Printing Office, 1922.)\*

## Philosophy: Psychology

**Alexander, A. B. D.** A Short History of Philosophy. Third edition, revised and enlarged. Demy 8vo. Pp. xv+648. (Glasgow: MacLehose, Jackson and Co., Ltd., 1922.) 12s. 6d. net.

**Bauch, B.** Jena und die Philosophie des deutschen Idealismus. Rede, gehalten zur Feier der akademischen Preisverteilung am 17. Juni 1922 in der Stadtkirche zu Jena von dem derzeitigen Rektor der Universität Jena. (Jena: G. Fischer, 1922.) 36 marks.

**Baudouin, C.** Studies in Psychoanalysis: an Account of Twenty-seven Concrete Cases preceded by a Theoretical Exposition. Comprising Lectures delivered in Geneva at the Jean-Jacques Rousseau Institute and at the Faculty of Letters in the University. Translated from the French by E. and C. Paul. Demy 8vo. Pp. 352. (London: G. Allen and Unwin, Ltd., 1922.) 12s. 6d. net.\*

**Boscovich, R. J.** A Theory of Natural Philosophy put forward and explained by Roger Joseph Boscovich, S.J. Latin-English edition. From the text of the first Venetian edition published under the personal superintendence of the Author in 1763. With a short Life of Boscovich. Imp. 4to. Pp. xix+470. (Chicago and London: Open Court Publishing Co., 1922.) 63s. net.\*

**Boussinesq, J.** Cours de physique mathématique de la Faculté des Sciences. Compléments au tome 3: Conciliation du véritable déterminisme mécanique avec l'existence de la vie et de la liberté morale. Roy. 8vo. Pp. xlviii+217. (Paris: Gauthier-Villars et Cie, 1922.) 30 francs.\*

**Brooks, H. J.** Universal Problems. Demy 8vo. Pp. 123. (Braintree: The Author, The Limes, Shalford, 1922.)\*

**Brown, W.** Suggestion and Mental Analysis: an Outline of the Theory and Practice of Mind Cure. Second edition, revised and enlarged. Cr. 8vo. Pp. 172. (London: University of London Press, Ltd., 1922.) 3s. 6d. net.\*

**Call, A. P.** Power through Repose. New edition, with additions. Cr. 8vo. Pp. 201. (London: Gay and Hancock, Ltd., 1922.) 3s. 6d. net.

**Carr, H. W.** The General Principle of Relativity in its Philosophical and Historical Aspect. Second edition, revised and enlarged. Cr. 8vo. Pp. viii+200. (London: Macmillan and Co., Ltd., 1922.) 7s. 6d. net.\*

**Casey, F.** Thinking: an Introduction to its History and Science. Cr. 8vo. Pp. 192. (London: Labour Publishing Co., Ltd., 1922.) 4s. 6d.

**Crespigny, Mrs. P. C. de.** The Mind of a Woman. Cr. 8vo. Pp. xii+318. (London: E. Arnold and Co., 1922.) 7s. 6d. net.

**Freud, S.** Vorlesungen zur Einführung in die Psychoanalyse. Taschenausgabe. Pp. iv+496. (Leipzig, Wien und Zürich: Internationaler Psychoanalytischer Verlag, 1922.)\*

**Freud, S.** Beyond the Pleasure Principle. Authorised Translation from the second German edition by C. J. M. Hubback. (The International Psycho-Analytical Library, No. 4.) Med. 8vo. Pp. v+90. (London: G. Allen and Unwin, Ltd.; Vienna: International Psycho-Analytical Press, 1922.) 6s. net.\*

**Gunn, J. A.** Modern French Philosophy: a Study of the Development since Comte. Med. 8vo. Pp. 358. (London: T. Fisher Unwin, 1922.) 21s. net.

**Hazlitt, H.** The Way to Will Power. Cr. 8vo. Pp. 159. (London and Toronto: J. M. Dent and Sons, Ltd., 1922.) 4s. 6d. net.

**Hsi, Chu.** The Philosophy of Human Nature. Translated from the Chinese, with Notes, by J. Percy Bruce. (Probsthain's Oriental Series.) Ex. Cr. 8vo. Pp. xvi+44. (London: Probsthain and Co., 1922.) 36s. net.

**Jaspers, K.** Psychologie der Weltanschauungen. Zweite, durchgesehene Auflage. Pp. xii+488. (Berlin: J. Springer, 1922.) 1920 marks.

**Miller, H. C.** The New Psychology and the Parent. Cr. 8vo. Pp. 255. (London: Jarrolds, Ltd., 1922.) 6s. net.

**Mitchell, T. W.** Medical Psychology and Psychical Research. Cr. 8vo. Pp. vii+244. (London: Methuen and Co., Ltd., 1922.) 7s. 6d. net.\*

- Pear, T. H.** Remembering and Forgetting. Cr. 8vo. Pp. xii+242. (London: Methuen and Co., Ltd., 1922.) 7s. 6d. net.\*
- Piccoli, R.** Benedetto Croce: An Introduction to his Philosophy. Ex. Cr. 8vo. Pp. xi+315. (London: Jonathan Cape, 1922.) 6s. net.
- Piéron, H.** Publiée par. L'Année psychologique. Vingt-deuxième année (1920-1921). Med. 8vo. Pp. xii+608. (Paris: F. Alcan, 1922.) 40 francs net.\*
- Platt, C.** The Psychology of Social Life: a Materialistic Study with an Idealistic Conclusion. Demy 8vo. Pp. 284. (London: G. Allen and Unwin, Ltd., 1922.) 12s. 6d. net.
- Quetta.** Voice Magnetism: the Psychology of Voice. Cr. 8vo. Pp. 40. (London: Henslow Press, 1922.)
- Richardson, G. A.** The Supremacy of Spirit. Cr. 8vo. Pp. viii+159. (London: Kegan Paul and Co., Ltd., 1922.) 5s. net.\*
- Russell, B.** The Analysis of Mind. (Library of Philosophy Series.) Demy 8vo. Pp. 310. (London: G. Allen and Unwin, Ltd., 1922.) 16s. net.
- Smith, W. W.** The Measurement of Emotion. (International Library of Psychology, Philosophy, and Scientific Method.) Demy 8vo. Pp. 184. (London: Kegan Paul and Co., Ltd.; New York: Harcourt, Brace and Co., Inc., 1922.) 10s. 6d. net.\*
- Spalding, K. J.** Desire and Reason: being an Account of the Origin and Development of Intellectual Principles. Demy 8vo. Pp. iii+220. (London: Kegan Paul and Co., Ltd., 1922.) 8s. 6d. net.
- Wheeler, O. A.** Bergson and Education. Cr. 8vo. Pp. vii+131. (Manchester: University Press; London: Longmans, Green and Co., Ltd., 1922.) 6s. 6d. net.
- Wittgenstein, L.** Tractatus Logico-Philosophicus. (International Library of Psychology, Philosophy, and Scientific Method.) Demy 8vo. Pp. 189. (London: Kegan Paul and Co., Ltd.; New York: Harcourt, Brace and Co., Inc., 1922.) 10s. 6d. net.\*

### Bacteriology

**Chandler, A. G.** Animal Parasites and Human Disease. Second edition, revised. Med. 8vo. Pp. 572. (New York: J. Wiley and Sons, Inc., 1922.) 4-50 dollars.

### Medicine: Surgery

**Bainbridge, W. S.** Le Problème du cancer. Traduit de l'anglais par le Dr. Hertoghe. 8vo. Pp. xxiii+484. (Louvain: A. Uystpruyst; Paris: G. Doin, 1922.) 32 francs.

**Barbour, A. H. F.** Gynecological Treatment. Med. 8vo. Pp. 123. (Edinburgh: W. Green and Son, 1922.) 7s. 6d. net.

**Barrett, A. T.** Dental Surgery. Cr. 8vo. Pp. 177. (London: H. Kimpton, 1922.) 6s. net.

**Chalotow, S. S.** Die anisotrope Verfertigung im Lichte der Pathologie des Stoffwechsels. (Die Cholesterindiathe.) (Jena: G. Fischer, 1922.) 640 marks.

**Dayme, H.** Le Médecin devant l'assistance et l'enseignement psychiatrique. Gl. 8vo. Pp. 125. (Paris: A. Maloine et fils, 1922.)

**Greif, U.** Zur Frage der Geschlechtskrankheiten. (Leipzig: W. Hartung, 1922.) 75 marks.

**Hazen, H. H.** Diseases of the Skin. Second edition. Roy. 8vo. Pp. 608. (London: H. Kimpton, 1922.) 37s. 6d. net.

**Hewetson, W. M.** Environmental Influences affecting Blondes in Rhodesia and their Bearing on the Future: a Survey of the Situation from the Medical and Scientific Standpoints. Being a Paper delivered before the Rhodesia Scientific Association at Salisbury, May 15, 1922. Demy 8vo. Pp. 27. (Salisbury, Rhodesia: Rhodesia Independent Co., Ltd.; London: Simpkin, Marshall and Co., Ltd., 1922.) 2s. 6d. net.\*

**Hewlett, R. T.** Pathology, General and Special, for Students of Medicine. Fifth edition. Demy 8vo. Pp. 542. (London: J. and A. Churchill, 1922.) 18s. net.

**Küstner, O.** Herausgegeben von. Kurzes Lehrbuch der Gynäkologie. Neunte, neubearbeitete Auflage. (Jena: G. Fischer, 1922.) 960 marks.

**Myers, B.** Practical Handbook on the Diseases of Children: for the Use of Practitioners and Senior Students. (Lewis's Practical Series.) Demy 8vo. Pp. xvi+548. (London: H. K. Lewis and Co., Ltd., 1922.) 21s. net.\*

**Nesfield, V.** Ophthalmic Surgery. Demy 8vo. Pp. 183. (London: H. K. Lewis and Co., Ltd., 1922.) 9s. net.

**Price, F. W.,** Edited by. A Text-book of the Practice of Medicine. (Oxford Medical Publications.) Med. 8vo. Pp. xxxvii+1753. (London: Oxford University Press, 1922.) 35s. net.

**Stitt, E. R.** The Diagnostics and Treatment of Tropical Diseases. Fourth edition, revised. Cr. 8vo. Pp. 635. (London: H. K. Lewis and Co., Ltd., 1922.) 18s. net.

### Miscellaneous

**Aigner, E.** Die neuesten Ergebnisse der Wünschelrutenforschung in Praxis und Theorie. Zum zehnjährigen Bestehen des Verbands zur Klärung der Wünschelrutenfrage. (Heft 9 der Schriften des Verbands.) Pp. 32. (Stuttgart: K. Wittver, 1922.)

**Bruns, F.** Die Zeichenkunde im Dienst der beschreibenden Naturwissenschaften. Pp. vii+100+44 Tafeln. (Jena: G. Fischer, 1922.) 90 marks.

**Department of Industrial and Scientific Research.** The Therm: Reports of the Fuel Research Board on Gas Standards. Cr. 8vo. Pp. 30. (London: H.M. Stationery Office, 1922.) 3d. net.\*

**Department of Scientific and Industrial Research.** Report of the Food Investigation Board for the Year 1921. Roy. 8vo. Pp. ii+47+4 plates. (London: H.M. Stationery Office, 1922.) 2s. net.\*

**Design in Modern Industry.** The Year-Book of the Design and Industries Association, 1922. With an Introduction by C. H. Collins Baker. Demy 4to. Pp. 157. (London: Benn Bros., Ltd., 1922.) 15s. net.\*

**Fulcher, G. S.** Indexing of Scientific Articles. (Reprint and Circular Series, No. 34.) Sup. Roy. 8vo. Pp. 16. (Washington: National Research Council, 1922.) 20 cents.\*

**Jackson, T. G., and Hustwick, W.** Practical Lessons in Book-keeping. Fifth edition. Cr. 8vo. Pp. viii+402. (London: University Tutorial Press, Ltd., 1922.) 5s.

**King, W.** Chelsea Porcelain. Med. 4to. Pp. xv+135+70 plates. (London: Benn Bros., Ltd., 1922.) 73s. 6d. net.\*

**Langie, A.** Cryptography. Translated from the French by J. C. H. Macbeth. Cr. 8vo. Pp. viii+192. (London, Bombay and Sydney: Constable and Co., Ltd., 1922.) 9s. net.\*

**McKay, H.** Easy Experiments in Elementary Science. Gl. 8vo. Pp. 144. (London: Oxford University Press, 1922.) 2s. 6d. net.

**Morgan, A. P.** The Boy's Book of Science and Construction. Large Cr. 8vo. Pp. xii+458. (London: Jonathan Cape, 1922.) 9s. net.

**Park, J.** A Text-book of Theodolite Surveying and Levelling, for the use of Students in Engineering, Land and Mine Surveying. (Griffin's Scientific Text-books.) Fifth edition, revised and enlarged. Ex. Cr. 8vo. Pp. xvi+557. (London: C. Griffin and Co., Ltd., 1922.) 30s. net.

**Patrick, C. V., and Smith, W. W.** The Case against Spirit Photographs. Med. 8vo. Pp. 47. (London: Kegan Paul and Co., Ltd., 1921.) 2s. net.\*

**Price, H.** Cold Light on Spiritualistic "Phenomena": an Experiment with the Crewe Circle. Demy 8vo. Pp. 15. (London: Kegan Paul and Co., Ltd., 1922.) 6d. net.\*

**Seabrook, W. P.** Fruit-Packing for Market: a Practical Treatise on the Grading, Packing, and Marketing of Hardy Fruit. (Issued by the Worshiptul Company of Fruiters.) Cr. 8vo. Pp. 90. (London: G. Allen and Unwin, Ltd., 1922.) 2s. 6d. net.\*

**Subject Index to Periodicals, 1917-1919, The. K: Science and Technology.** Roy. 4to. Pp. 555. (London: Library Association, 33 Bloomsbury Square, 1922.) 35s. net.\*

**Thomson, J. A.,** Edited by. The Outline of Science: A Plain Story Simply Told. Vol. 2. Demy 4to. Pp. iv+401-812. (London: G. Newnes, Ltd., 1922.) 31s. 6d. net.

**Weston, W. J.** Banking and Currency. Cr. 8vo. Pp. viii+330. (London: University Tutorial Press, Ltd., 1922.) 5s. 6d.



## Pasteur.

By STEPHEN PAGET.

OF late years it has become the fashion to limit the name of preventive medicine to the immunisation of ourselves or of animals against infection. With the one exception of vaccination against smallpox, all methods of immunisation are founded on Pasteur's work. The contrast is remarkable between Jenner's discovery and Pasteur's many discoveries. Jenner, ages back,

made a great discovery: but there he stopped. Pasteur not only made discoveries: he made discoverers. We are so accustomed nowadays to the new learning which he brought into the world that we are in danger of forgetting the original wonder of it: the power to identify, isolate, cultivate, and handle, outside the living body, this or that disease: to hold in a test-tube the actual cause, the thing itself, the very stuff of disease, growing under our eyes. That is the tragedy of Semmelweis: he worked out the truth about puerperal fever, but he could not demonstrate the germs of it: therefore he was contradicted,

bullied, hounded down, driven mad, and died insane in 1865. Pasteur, in 1878, in a discussion at the Académie de Médecine on puerperal fever, when one of the speakers railed at Streptococcus as a non-reality, forthwith drew Streptococcus on the blackboard, saying, "Tenez, voici sa figure."

After all, it is impossible, in Pasteur's work and its influences, to separate preventive medicine from curative medicine. Long before Pasteur died every country was at work on his lines. We can take some

dates in his life: but he was always living in the work of lesser men whom he inspired. The dates in his life are as follows. In 1842, fortified by the virtues of home-love, and by the courage of youth, he went to Paris: entered the École Normale in 1843: worked under Dumas and Biot at chemistry, and at chemistry only: and in 1848 he solved the problem of the different

forms of tartaric acid. For this reason he has been called the founder of stereo-chemistry. His pursuit of the tartrates led him straight to the practical study of the processes of brewing, distilling, vinegar-making, and wine-making. By this work on fermentation, Huxley said of him that he saved France more than enough to pay the indemnity of the Franco-German War. In 1857 came his paper at the Lille Scientific Society on *Bacterium lactis*: he had isolated this ferment, had experimented with it: and this "inoculation" of milk with a culture of germs was the beginning of all bacteriology.

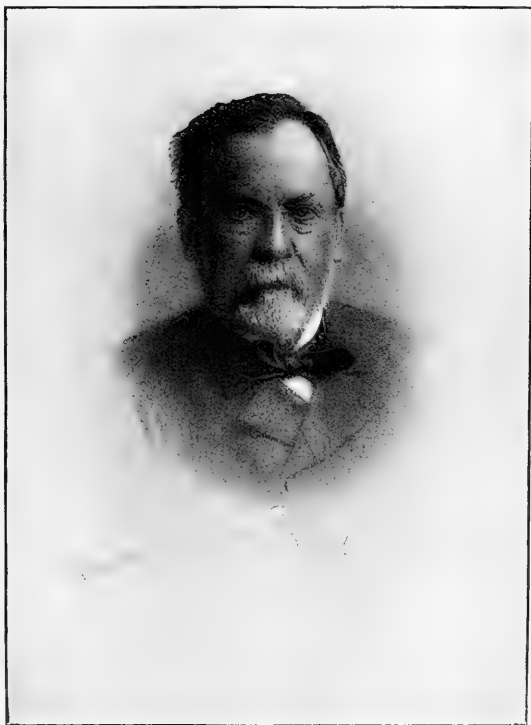

FIG. 1.—Pasteur. 1822-1895.

From 1865 to 1870, without giving up his work on ferments, Pasteur set himself, at Alais, to investigate the silkworm disease, which was wrecking the silk-industry of France and other countries. He found not one disease but two—*pêbrine* and *flacherie*. The story of his final triumph, after infinite difficulties, in this investigation is marvellous: it is told in his "Études sur les maladies des vers à soie." He used to commend this book to students to guide them in the principles of their work.

Meanwhile, in Paris, Pasteur was advancing from his knowledge of the putrefying of milk with *Bacterium lactis* to the general study of putrefaction as a state of fermentation caused by the living dust in the air. Liebig had thought of putrefaction as a chemical degeneration: Pasteur thought of it as a vital process. It was more than a result of death: it was the act of life. By 1859, the year of publication of "The Origin of Species," he was in the thick of the fight over the origin of life. He in France, and Tyndall in England, proclaimed and proved the truth of "the germ theory": that was our phrase for Pasteur sixty years ago, because the notion of putrefactive bacteria was new to us. This controversy, in scientific and non-scientific society, lasted long. In April 1864 Pasteur lectured at the Sorbonne to all Paris: he reviewed and demonstrated his work; he answered his critics: "I have excluded from my flasks of organic fluids, and am still excluding from them, the one thing which is past man's making: I have excluded from them the germs which float in the air, I have excluded from them life." Finally, he put in very short words the meaning of it all—"La vie c'est le germe, et le germe c'est la vie."

In 1862 Pasteur had noted the presence of germs in ammoniacal urine, such as occurs with cystitis. In 1863 he had told Napoleon III. that his one ambition was to get to know the causes of putrid and contagious diseases. In 1865, when the cholera was raging in Paris, he and Claude Bernard and Deville made many experiments, in vain, on the air of a cholera-ward. That year also, in Glasgow, Lister, sick to death of the old hospital-diseases, set himself, by the "flood of light" which came to him from Pasteur, to prevent wound-infection by dressing wounds with carbolic acid. He was, of course, hampered by the need of wider knowledge, and by undue fear of the "putrefactive bacteria" in the air. Besides, his first carbolic acid was fallible stuff: he would have done as well, or better, with iodine or spirit. But the point is, that he had got hold of principles that are infallible. He had abandoned the fatal notion that putrefaction was caused by the oxygen of the air. Under this notion he had worked hard, in vain, to prevent wound-infection. "But when Pasteur had shown that putrefaction was a fermentation caused by the growth of microbes, and that these could not arise *de novo* in the decomposable substance, the problem assumed a more hopeful aspect. If the wound could be treated with some substance which, without doing too serious mischief to the human tissues, would kill the microbes already contained in it and prevent the future access of others in the living state, putrefaction might be prevented, however freely the air with its oxygen might enter" (Lister's presidential address to the British Association, 1896). On these principles—with many

changes and improvements of the original method of "Listerism"—all that we call antiseptic and aseptic surgery was founded and built.

In the war of 1870-71, the French Army suffered heavily from wound-infection. After 1871, while Lister was practising Pasteurism in Edinburgh, Pasteur was teaching Listerism in the hospitals of Paris, and was defending it against the old school of practitioners. Thus he was one of the founders of modern surgery in France. During this phase of his work he identified Streptococcus alike in boils and in osteomyelitis, and properly said that osteomyelitis is "a boil in a bone."

In 1877 came the beginning of Pasteur's threefold work on anthrax, chicken-cholera, and swine-erysipelas. In this colossal work, between 1877 and 1881, Pasteur discovered and proved the use of standardised vaccines. By keeping pure cultures of chicken-cholera, he could bring down their virulence, slowly and steadily, from day to day. By passing this attenuated virus through a succession of small birds, such as sparrows or canaries, he could restore it, point by point, to its full strength. By keeping at a lowered temperature pure cultures of anthrax, he could hinder their springing, and bring down their virulence. By passing this attenuated virus through a succession of guinea-pigs, he could restore it, point by point, to its full strength. With such methods of attenuation and intensification, he was able to standardise diseases in flasks: able to make and to store vaccines, exactly graduated by a fixed scale of their strength. As Roux said of it all, "See how far we have come, from the old metaphysical ideas about virulence, to these microbes that we can turn this way and that way—stuff so plastic that a man can work on it, and fashion it as he likes."

Finally, in 1880-85, Pasteur discovered and established the preventive treatment against rabies. He could not isolate and identify the bacteria of the disease: but his work was on the lines of bacteriology. By a long series of experiments, he obtained his *virus fixe*, his standard of the disease, raised by intensification to such a point that the latent period in rabbits after inoculation with virulent spinal cord, lasted only for six or seven days, never more, never less. This *virus fixe* was even stronger than the virus of an ordinary case of rabies. Moreover, it retained its strength through any number of passages from animal to animal. In brief, he standardised rabies, not in flasks but in rabbits: he shortened its latent period to 6-7 days, and fixed it there. Last of all, as with chicken-cholera, so with rabies, he proved that the spinal cords of rabbits infected with his *virus fixe* lost virulence, slowly and steadily, point by point, by mere keeping. Thus he was able to preserve and

stock, in a complete set of cords, the dried virus of rabies, in every shade of strength, from non-virulence up to full virulence. [With a course of vaccines made from these cords, beginning at non-virulence, he could immunise his patients—each dose being made safe by the dose of the previous day. He could do this while the disease itself was latent in the scar of the bite, locked-up and inert. He could outwit the natural disease: could take advantage of its latent period, and deprive it of its one and only chance of flaring-up.

Long before 1885, Pasteur's teaching went all over the world. Between 1880 and 1890 came the discoveries of the germs of tubercle, cholera, diphtheria, tetanus, and Malta fever. In 1893, diphtheria antitoxin, and the protective treatment against cholera. In 1894, tetanus antitoxin. In 1896-97, the protective treatments against typhoid and plague. And so on.

There is no room here to try to guess how many

millions of animal lives have been saved or safeguarded by the protective treatments against anthrax, rinderpest, or pleuro-pneumonia: no room to say what has been gained by the mallein test for glanders. Whether we look at the animal creation or at our own, we find everywhere the following-out of the new learning which Pasteur made possible.

The War demonstrated, on a vast scale, the supreme importance of the methods of preventive medicine. They go back, all of them, to that original plan of isolating, cultivating, and finally standardising and grading, the agents of disease: that plan which Pasteur took in hand in 1877.

Happy are those of us who remember the joy of seeing him, hearing him, shaking hands with him. Let alone the wonder of his discoveries, there is the wonder of the beauty of his spiritual gifts. Our

admiration of what he did for us cannot hide from us what he was in himself.



FIG. 2.—Pasteur statue at the Sorbonne, Paris.

#### Pasteur Aphorisms.

SCIENCE has no nationality because knowledge is the patrimony of humanity, the torch which gives light to the world.

\* \* \*

If science has no country, the man of science should have one, and ascribe to it the influence which his works may have in this world.

\* \* \*

The cultivation of science in its highest expression is perhaps even more necessary to the moral condition than to the material prosperity of a nation.

\* \* \*

Science should be the highest personification of nationality because, of all the nations, that one will be foremost which shall be first to progress by the labours of thought and of intelligence.

\* \* \*

Nothing is more agreeable to a man who has made science his career than to increase the number of discoveries, but his cup of joy is full when the result of his observations is put to immediate practical use.

Blessed is he who carries within himself a God, an ideal, and who obeys it; ideal of art, ideal of science, ideal of the gospel virtues, therein lie the springs of great thoughts and great actions; they all reflect the light of the Infinite.

\* \* \*

... two contrary laws seem to be wrestling with each other nowadays; one, a law of blood and death, ever imaging new means of destruction and forcing nations to be constantly ready for the battlefield—the other, a law of peace, work and health, ever evolving new means of delivering man from the scourges which beset him.

\* \* \*

... the characteristic of erroneous theories is the impossibility of ever foreseeing new facts; whenever such a fact is discovered, those theories have to be grafted with further hypotheses in order to account for them. True theories, on the contrary, are the expression of actual facts and are characterised by being able to predict new facts, a natural consequence of those already known. In a word, the characteristic of a true theory is its fruitfulness.

## The Influence of Pasteur on the Development of Bacteriology and the Doctrines of Infection and Immunity.

By Prof. WILLIAM BULLOCH, F.R.S.

TO the ancients the cause of plagues and epidemics was a great mystery. Such visitations were regarded either as punishments administered by the Omnipotent to chastise his erring creatures, or as the foul work of a spirit or demon who possessed the powers of evil over men. It was natural that human beings who possessed the ability to ward off the avenging hand or to neutralise the deadly effects of a cacodemum should be esteemed or, indeed, venerated. This was, no doubt, the origin of the Æsculapian worship in ancient times, and was the source of charms, the use of which is not extinct even now. In any case, the cause of disease was believed to be something supernatural, and this was the current doctrine down to the Middle Ages, to be replaced by the view that the cause must be sought in some natural phenomenon rather than a vague supernatural element. Among natural causes of disease were reckoned deleterious changes in the air from miasms emanating from the soil, the effluvia given off from unburied bodies, and such like. Changes in weather were also believed to be effective, and a vague "epidemic constitution"—a "genius epidemicus"—was utilised to explain the repeated appearance of diseases like small-pox, measles, influenza, and scarlet fever. There were also those who believed that telluric influences like earthquakes and floods, or celestial phenomena like the conjunction of planets or eclipses, were responsible for the subsequent outbreaks of epidemic disease.

The idea that disease could be contracted by contact with the sick, although ancient, was never popular and played no important part in the evolution of medical doctrine until the sixteenth century, when its main elements were clearly formulated by Jerome Fracastori (1483-1553) whose work "De Contagione" (1546) constitutes a great landmark in medical history. He clearly differentiated (a) contagion by contact, (b) contagion by fomites, and (c) contagion at a distance. The starting point of his work was the appearance of syphilis, which spread over Europe as a great pandemic at the end of the fifteenth and the beginning of the sixteenth century. In addition to syphilis, small-pox, itch and hydrophobia were clearly recognised as syphilitic. Contagion, however, did not explain all epidemic diseases. For example, it was clear that, although malaria affected large numbers of people, it was not dangerous for the healthy to come even in remote contact with the sick. Such a disease was believed to be due to some pollution of the air—

a miasm, *mal aria*, emanating from marshes. In this way miasmatic were differentiated from contagious diseases, while later, a group of miasmatic-contagious diseases was included. In all cases the miasm, which was not believed to be transmissible directly, was regarded as undergoing some process of maturation in soil, air, or water. At this period, indeed, the influence of the soil and air was regarded as paramount.

By degrees, however, the doctrine of infection clearly emerged and passed through three phases. At first there was the idea that the disease cause was poison was not more nearly defined. The poison was then regarded as the action of a ferment, and the name zymotic still persists. Lastly, in the nineteenth century, the idea became prevalent that the disease cause is not a vague chemical ferment but a living fermenting agent—a *contagium vivum*. The foundation of this great advance is to be sought in the classical observations of Cagniard-Latour (1836) and Theodor Schwann (1837) that yeast—a substance known from time immemorial—is a living organism reproducing itself by a process of budding and producing chemical changes in certain substances termed fermentable. Schwann, in particular, showed that while no yeast cells are to be found in fresh grape juice, their addition to such grape juice is followed by the infallible signs of fermentation and the production of gas. This view, opposed as it was to the prevailing teaching of chemistry, was at first ardently opposed, but in due course was accepted as indicating the truth.

One of the earliest investigators to realise the possibilities of the work of Schwann was Henle the anatomist, and so long ago as 1840 he developed the idea, on theoretical grounds, that microscopic living beings might be the causes of disease; with a remarkable prescience he set forth the principles whereby this might be experimentally proved. Indeed, his suggestions constituted the nucleus on which, forty years later, the whole modern fabric of the etiology of infective diseases was erected. Even so far back as 1835, Agostino Bassi, of Lodi, showed that the muscardine disease of silkworms was due to infection by a fungus. In 1839, Schönlein demonstrated the existence of the Achiorion fungus in favus, and Gruby (1843) found the Trichophyton fungus in ringworm.

A new stream of discovery had set in, no longer characterised by vague philosophical speculation but by hard facts established by experiment. To this advancing current Louis Pasteur was the main con-

tributor, and it was chiefly his work that led to the so-called "germ theory" of disease, which by 1876 became an established fact. Pasteur's work on fermentations showed that different chemical products are the outcome of the activities of particular microbes, subsisting in and utilising the fermentible substances. His observations on the alcoholic, lactic, butyric, acetic, urea fermentations, and the abnormal fermentations of wines and beers, are classic and have remained the teaching of to-day. It was by an accident that he was dragged into the conflict on spontaneous generation and heterogenesis, and in a short time and by unsurpassed technique answered the question in the "not proven" sense. Of his principal paper on this subject published in 1862, Tyndall, himself a great experimenter, has said that "clearness, strength, and caution with consummate skill for their minister were rarely more strikingly displayed than in this imperishable essay." Pasteur's works on fermentation and on spontaneous generation acted like a leaven on medical thought, and was the principal cause of the immense advances which, shortly afterwards, took place in our ideas of disease causes. In particular his demonstration of "panspermia," the idea that germs abound everywhere, was the origin of the life work of Lister on the protection of wounds from extraneous contamination and his foundation of antiseptic surgery—the greatest advance ever made in medical art. While Lister throughout his life always referred modestly to his own share in the work, it is by no means to be supposed that he was a mere imitator of Pasteur. Lister was the first to visualise the enormous practical importance of Pasteur's work, and himself was the creator and the greatest exponent of the whole antiseptic advance.

It was also Pasteur's demonstration of specific fermentations that led Davaine (1863) to renew his observations on the bacteria seen years before by him with Rayer in anthrax blood, and by Pollender and Brauell. Pasteur himself followed all these advances with keen insight and appreciation, and was thereby brought into personal contact with disease processes although he had no medical training. In particular, he spent the later part of his life in elucidating infectious animal diseases like fowl cholera, swine erysipelas, anthrax, and hydrophobia. Not only did he show that these diseases are due to special microbes differing from each other and producing the specific disease, but he was enormously ahead of his time in discovering prophylactic measures by which these diseases can be prevented by inoculation. One of his greatest discoveries—and one which pervades all his later work—was the demonstration that an attenuated living virus, *i.e.* one no longer capable

of causing fatal disease—can by inoculation lead to the prevention of fatal disease. As Jennerian inoculation of calf lymph belongs essentially to this category, Pasteur proposed to designate the method by the name "vaccination," although, in so doing, the etymological significance of the word was lost. Pasteur was the discoverer of extraordinary forms of microbes which live without air—anaerobes—and himself discovered the first disease-producing microbe of this class, namely, *Vibrio septique*. Since his time the knowledge of pathogenic anaerobes has grown to a special department of bacteriology.

By degrees the fundamental doctrine of the specificity of disease became firmly established. The idea first emanated from the fertile mind of P. F. Bretonneau, the French clinician, who in the beginning of the nineteenth century overthrew the prevailing doctrines of Broussais, and showed that diseases vary from differences in *cause* rather than from the *intensity* of the cause or the *environment*. The actual demonstration of specificity in infective disease is one of the great achievements of modern pathology, and was shown in particular by Robert Koch, who in 1876 introduced simple methods for bacterial cultivation which have not been materially altered down to the present time. Koch's principle utilised media (*e.g.* gelatine) which were fluid at one temperature and solid at another. By disseminating the microbes in the fluid medium and suddenly solidifying it the bacteria were, so to speak, imprisoned and started to grow and in this way "pure cultures" were easily obtained. Viewing Koch's pure cultures in London in 1881 in Lister's laboratory at King's College, Pasteur, turning to Lister, said, "C'est une grande découverte." It was the application of Koch's method in his own hands and those of his assistants that, in the decade 1880-1890, revolutionised the subject of disease causation, and led to the discovery of more solid facts than had been possible since the dawn of civilisation.

The discovery of the microbes of tuberculosis, cholera, diphtheria, glanders, and enteric fever in this decade renders it one of the most fertile in the history of medicine, and was the classical period when the science of bacteriology was founded. Since 1890 the current has flowed in another direction, namely, towards the prevention and cure of specific infective disease by specific remedies, and it was here that Pasteur's main work on the effects of attenuated virus led and still leads the way. When one calmly surveys the immense progress of medical science in the last fifty years it will, we think, be admitted by future historians that its progress and success were due largely to the work initiated with so much imagination and carried out with such incomparable technical skill by Louis Pasteur.

## Pasteur and Preventive Medicine.

By Prof. J. C. G. LEDINGHAM, F.R.S.

PASTEUR'S life-work is a finished symphony, a science in miniature, and it is, perhaps, not generally appreciated that the Master was well advanced in years when he commenced the final chapter which witnessed that remarkable series of experiments in prophylactic immunisation which culminated in his dramatically successful attack on rabies. This crowning victory over a dreaded scourge was rendered possible by Pasteur's profound faith in the immunising powers of attenuated viruses—a faith which his previous experience with fowl cholera, swine erysipelas, and anthrax had but strengthened. It was in essence the faith of Jenner.

Pasteur commenced the final chapter of his life, which he devoted to preventive medicine, as the complete comparative pathologist and he remained one to the end. It is true that fowl cholera and anthrax were among the few infections of which the microbic agents were at least known, though meagrely studied. The great chain of discoveries in the causation of human infections dating from the early 'eighties, and inspired by the genius of Koch's pure culture studies, was yet unforged, and in that work Pasteur and his school took little share. To Pasteur the accurate knowledge of a virus was simply a stimulus to attack the disease on the preventive side, but neither to him nor to his great contemporary Lister was this stimulus an essential one. If a virus could be demonstrated and cultivated outside the body, so much the better. Attenuation was all the simpler. So when he came to rabies, ignorance of the actual virus did not deter him from the attempt to attenuate its virulence by an ingenious method of his own and to render it amenable for prophylactic use. His demonstration of the predilection of rabies virus for brain and spinal cord supplied the key that opened the secret door.

It is fortunate, perhaps, that Pasteur's activities in preventive medicine were solely concerned with veterinary disease. There he had full scope for animal experiment on the large scale and he could assess at will the value of a prophylactic measure under controlled experimental conditions. That day at the farm of Pouilly-le-Fort when he arrived to find the vaccinated sheep and cattle alive and well, while all the unvaccinated controls were dead or dying of anthrax, must have been a glorious date in a calendar that held many such. But all systems of immunisation, whether in man or animal, when brought to the test of the field experiment, reveal their relative value, and Pasteur's essays have been no exception to the rule. His guiding principles in immunisation have, however, easily stood the light of fifty years and never were they more keenly debated than to-day, when the factors that control the vagaries of bacterial virulence are just beginning to be understood. Pasteur was, perhaps unconsciously, the first exponent of bacterial variation, a field of work that exercises many minds to-day and bids fair to yield a rich harvest. Attenuation was secured by Pasteur in several different ways, in fowl cholera by prolonged incubation of the virus, in swine erysipelas by passage through another animal species, and in anthrax by altering the temperature of incubation.

What amount of success has been achieved since then in prophylaxis against human infections is due to the substitution of the killed for the attenuated live virus—certainly an expedient, but very possibly a retrograde, modification of Pasteur's principle. The solution of the mysteries of attenuation, to which renewed study is being devoted, may yet open up new vistas in prophylaxis and in serum-therapy, but to Pasteur's pioneer work in this field, preventive medicine must for ever pay homage.

## Pasteur in Crystallography.

By Dr. A. E. H. TUTTON, F.R.S.

IT is very rare indeed that a scientific man of our time is equally distinguished for his researches in both the great fields of natural science, the chemical and the biological, yet this is true of Louis Pasteur. His fame as a chemical crystallographer was assured for all time by his brilliant discovery, as a young man of twenty-six in the year 1848, of the true nature of tartaric acid, by his measurement of the crystals of the two optically active varieties, and by his revelation of the connexion between right- and left-handedness of crystalline form (enantiomorphism) and optical

activity. This particularly interesting property of rotating the plane of polarisation of a ray of polarised light has been said by Prof. Percy Frankland to be "the distinctive seal of nobleness exhibited by the aristocracy of chemical compounds." The distinction achieved by Pasteur in the biological world, great as it is, rendering his name a household word among us and one to be blessed by generations yet to come, is thus at least equalled by his pioneer services to crystallography.

It is somewhat remarkable that Mitscherlich in the

year 1819 should have made his celebrated discovery of isomorphism during his first research, that Scheele in 1769 should have isolated tartaric acid as the result of his first investigation, and that Pasteur in 1848 should have discovered the great principle of enantiomorphism and the generalisation connecting it with optical activity now known in crystallography as Pasteur's Law, as the result of his earliest research. Young post-graduates setting forth on their first steps in scientific research may find great encouragement from these interesting facts.

In the year 1819 an acidic substance greatly resembling the tartaric acid discovered by Scheele had been found in the grape-juice vats of Thann in Alsace, and in 1826 it was investigated by Gay Lussac, who was obliged, however, to confess himself puzzled as to the nature of the substance. Gmelin also examined it in 1829, with a similar result, but he at least gave it a name, Traubensäure—acid of grapes—which was translated as racemic acid in France and England. Subsequently Berzelius tackled it, and got so far as to prove that its empirical composition was  $C_4H_6O_6$ , the same as that of Scheele's tartaric acid, this observation being indeed the introduction of the principle of isomerism into chemistry. Shortly afterwards Biot, who subsequently became the close friend and admirer of Pasteur, in the course of his pioneer work on the rotation of the plane of polarisation of light by certain specific substances, examined for rotatory power both this racemic acid and tartaric acid. He found that the latter, both the crystals and their solution in water, rotated the plane of polarisation to the right, but that racemic acid was optically inactive.

It was at this juncture that Pasteur took up the study of the subject, concentrating his attention first on racemic acid and its salts. One of the most readily obtainable is sodium hydrogen racemate, and when to the solution of this salt in water ammonium hydrate is added, the salt sodium ammonium racemate crystallises out on standing, its composition being  $C_4H_4O_6 \cdot NaNH_4 \cdot 4H_2O$ . It was in examining these crystals that Pasteur made the initial discovery which led to all the rest. For he observed that in some of the crops obtained all the individual crystals were either right-handed or left-handed, the two varieties being, when analogously equally developed, the mirror-images of each other. Moreover, crystals of either kind at will could be obtained from a metastable (saturated at 28° C. and cooled to ordinary temperature) solution of the salt by touching the solution with a crystal of the desired variety. The crystals belong to the rhombic bisphenoidal class 6, the faces of complementary bisphenoids being present on opposite sides on the two kinds of crystals.

On collecting crystals of each variety apart, redissolving them and recrystallising, the fresh crystals proved to be of the same kind as those dissolved; and on precipitating a solution of each variety with a soluble lead salt and decomposing the precipitated lead salt by means of sulphuretted hydrogen, Scheele's ordinary dextro-tartaric acid was obtained in one case, while the other variety gave quite a new form of tartaric acid, the crystals and solution of which rotated the plane of polarisation to the left. This was, in fact, the isolation by Pasteur of lævo-tartaric acid. Further, on mixing the two separate acids thus derived, right-handed and left-handed, he noticed that heat was evolved, a molecular combination of the two varieties occurring, the product being racemic acid, which crystallised out with a molecule of water of crystallisation,  $C_4H_6O_6 \cdot H_2O$ . Thus he discovered the true nature of racemic acid, namely, that it is a molecular compound of the two optically active tartaric acids, the two varieties exactly neutralising each other and producing thereby optical inactivity.

Pasteur must have had some considerable crystallographic knowledge, for he measured crystals of dextro-tartaric acid and made observations with lævo-tartaric acid which were adequate to prove that its crystals were the mirror-images of those of the ordinary dextro acid. The crystals belong to the sphenoidal class 4 of the monoclinic system. Typical crystals of the two varieties are shown in the accompanying Figs. 1 and 2, and it will be clear that the dextro variety, Fig. 1,

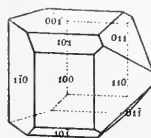

FIG. 1.  
Dextro-tartaric acid.

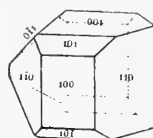

FIG. 2.  
Lævo-tartaric acid.

exhibits the right clino-prism  $\{011\}$ , while the lævo variety, Fig. 2, has only the left clino-prism  $\{0\bar{1}1\}$  developed, of the two possible sphenoids, the distinctive forms of this class of lower than holohedral symmetry.

These crystals of the two optically active tartaric acids are anhydrous, corresponding to the formula  $C_4H_6O_6$ . On the other hand, racemic acid, as already mentioned, crystallises with a molecule of water, and the crystals are quite different and of only one kind, belonging to the pinakoidal holohedral class 2 of the triclinic system, as subsequently established by De la Prevostaye. The combination of the two optically active varieties, however, is so loose that the separation into the two kinds already described is possible, under the specific conditions stated.

In the year 1850 Pasteur discovered yet a fourth variety of tartaric acid—meso-tartaric acid—which is truly and permanently without action on the plane of polarisation of light, and so is quite unresolvable into two optical antipodes. This further fact threw great light on the subject, and eventually Pasteur showed that the explanation of the whole matter is to be found in the symmetry or dissymmetry of the chemical molecules themselves. Not only is the empirical formula the same for all, but the constitutional formula written in one plane is also identical, namely,

$$\begin{array}{c} \text{CHOH-COOH} \\ | \\ \text{CHOH-COOH} \end{array};$$

but the atoms or groups are differently disposed in space in these different physical isomers.

Physical isomerism is possible when the substance possesses what has since been called an asymmetric carbon atom, an atom of carbon of which the four tetrahedrally disposed valency bonds are satisfied by four different elements or groups. Optical activity is usual in all such cases, but it has more recently been shown that it is not the absolutely essential condition for the development of optical activity, the absence of second order symmetry elements (planes of symmetry or second order axes) and possession of only first order (axial) symmetry being the more truly determinative condition for the development of two enantiomorphous varieties of physical isomerides and of their accompanying opposite optical activities. Tartaric acid, however, does possess this essential condition, and it has also two asymmetric carbon atoms, namely, those in the two CHOH groups (starred)

of the constitutional formula

$$\begin{array}{c} * \text{CHOH-COOH} \\ | \\ * \text{CHOH-COOH} \end{array}$$

and the

group of atoms in one half-molecule may be either symmetrically disposed with respect to those of the other half-molecule or differently disposed. When they are symmetrically arranged, internally compensated, the whole molecule is optically inactive, this corresponding to the case of the truly inactive tartaric acid; when they are unsymmetrically arranged they are so in either a right- or a left-handed manner, the crystals being helically constructed (recently confirmed by X-ray analysis) as a right or left screw, giving rise to the two optical enantiomorphous antipodes, as in the case of dextro- and lævo-tartaric acids. Racemic acid, the molecular combination of the two last mentioned, is the case of external compensation as regards the molecules.

The work during the present year of Mr. W. T. Astbury in the laboratory of Sir William Bragg, on the X-ray analysis of tartaric acid, the results of which have just, most opportunely, been communicated to the Royal Society, has proved without a shadow of

doubt that the four atoms of carbon in the molecule of ordinary dextro-tartaric acid are, in very truth, spirally arranged. This is a most welcome confirmation of Pasteur's great work on the very eve of his centenary.

The principles on which the whole of these results are based were eventually summarised in what has since become known as Pasteur's Law, which may be briefly stated thus:—"If the atoms of a chemical molecule be dissymmetrically arranged, this molecular dissymmetry implies the possibility of the existence of two oppositely complementary configurations of the molecule. Both varieties have the same chemical properties, and they are endowed always with equal but oppositely directed rotatory power. The presence of molecular dissymmetry therefore reveals itself by this rotatory power of the molecules and is wholly determined by their chemical constitution. When the atoms of a chemical molecule are dissymmetrically arranged, the fact is at the same time betrayed by the occurrence of the two varieties in complementary non-superposable crystalline forms, possessing screw axes of opposite winding."

This purely chemical and crystallographic work of Pasteur was connected with his later bacteriological and zoological work by the further pioneer observation that when the spores of the ferment *Penicillium glaucum* were added to a solution of racemic acid containing a small quantity of phosphates (which appear to be essential to the life of the organism), the dextro component of the molecular compound of the two varieties of optically active tartaric acid is somehow isolated and eaten up by the organism, leaving the lævo component untouched so long as any dextro acid remains. Why this is so is a mystery still, connected with life itself. By arresting the fermentation at the psychological moment, the residual lævo variety can thus be isolated and crystallised out tolerably pure, and its isolation was, as a matter of fact, thus effected for the first time in yet a second manner by Pasteur, and its crystals shown by him to be the mirror-images of those of Scheele's ordinary dextro-tartaric acid.

This observation by Pasteur has developed into a general method for the fissure and separation of the two separable varieties of a racemic compound—for many such compounds have since been discovered—and for the isolation of one of them, the other being chosen in some mysterious way for preferential destruction by the organism, in assimilating it for its own nourishment and reproduction. Thus the great value of the classic work of Pasteur on the tartaric acids lies in the fact that this group of compounds proved to be but a type of a large class of substances, which exhibit physical isomerism in two enantiomorphous varieties that are optically active in opposite directions and



combine molecularly to form compounds of racemic character. His methods and his law have thus come to be of wide, indeed general, application to all such cases. With regard to the deeply interesting question why so slight a difference of nature, between two varieties of a substance, as a mere difference of type of helix—right- or left-handed—along which the atoms are arranged, should be a sufficient cause for the different behaviour of a living organism brought into contact with it, remains still unsolved. The fact,

however, has been amply confirmed over and over again, as well as by Emil Fischer's results on the selective fermentation of sugars by yeasts, so that it appears as if the action of every living organism corresponds to only a particular arrangement of the atoms in a chemical molecule. Pasteur himself says (1860), and with these words of still valid portent this article may well conclude: "Il y a là des mystères, qui préparent à l'avenir d'immenses travaux et appellent dès aujourd'hui les plus sérieuses méditations de la science."

### Pasteur's Early Research in Pure Chemistry and Fermentation.

By Prof. ARTHUR HARDEN, F.R.S.

THE purely chemical researches of Pasteur, undertaken when he was a young man of twenty-two years of age, were all comprised within the epoch 1844-1860, during the latter part of which he was also actively engaged on his great work on fermentation. Pasteur's fundamental contribution to pure chemistry, the idea of the asymmetric arrangement of the atoms within the molecule, has proved to be one of the most fruitful conceptions of the science. The experimental methods which led to its development have provided chemists with a weapon by which many of the most difficult and subtle problems have been successfully attacked; a weapon which still maintains its place in the armoury of the chemist and is every day turned to fresh account.

Pasteur's fundamental experiment on the resolution of the racemates, and the dramatic scene in which his great discovery was recognised by the veteran Biot, are among the classics of chemical literature. The thrill accompanying the culmination of this his first successful research, the memory of that joyous nervous excitement which prevented him from again looking into the polarimeter, must have always remained vividly present to his mind and can never have been effaced even by the ever-increasing flood of discoveries which marked his later years.

Stereochemical relations are now so well established and so universally admitted that it is difficult to realise the intrepidity of Pasteur's theoretical deductions. He saw at once that the asymmetry of his two tartaric acids would lead them to form different compounds with an asymmetric (optically active) base. On making the experiment, after many abortive attempts, he at length had the satisfaction, second only to that experienced at the successful resolution of the racemates, of obtaining crystals of pure cinchonine levotartarate by the crystallisation of the racemate of this optically active base. Thus was established the classical chemical method for the resolution of asymmetric compounds.

It is of special interest, in view of the later direction

of Pasteur's scientific work, that he at once perceived the bearing of his new discoveries on the chemistry of the living organism. It was only among the products of vegetable and animal life that he found substances the molecules of which were asymmetric. In the mineral kingdom and among the synthetic products of the organic chemist molecular symmetry held undisputed sway. He therefore regarded the living organism as the sole source of asymmetric molecules, the cell acting as "a laboratory of asymmetric forces." Observation soon reinforced these theoretical ideas. Struck by the "spontaneous" fermentation of a solution of ammonium tartrate, he transferred a drop of the fermenting liquid to a solution of ammonium racemate and found that when the fermentation which ensued had ceased the levotartarate was quite intact whereas the dextro-acid had disappeared. "Thus" says Pasteur, in his lectures on Asymmetry,<sup>1</sup> 1860, "the conception of the influence of the molecular symmetry of natural organic products is introduced into physiological studies through this important criterion (optical activity), which forms perhaps the only sharply defined boundary which can at the present day be drawn between the chemistry of dead and living nature."

It was, according to Duclaux in his charming biography "Pasteur, histoire d'un esprit," another aspect of the relation between organisms and the asymmetry of their products which led him to the study of fermentation, his next great field of discovery. Amyl alcohol, the optically active constituent of fusel oil, was at that time universally supposed to be derived from the sugar, although it is now known, through the brilliant researches of Felix Ehrlich, to be a product of the decomposition of protein. This substance was assumed by the opponents of the vitalistic theory of fermentation, which had been based on the discovery of the living nature of yeast in 1837, to owe its optical activity to the parent molecule of sugar from which it

<sup>1</sup> Quoted from Frankland's Pasteur Memorial Lecture, *Jour. Chem. Soc.*, 1897.

was derived. Pasteur, in view of his experiments on the decomposition of active substances, which gave rise to inactive products, could not accept this idea, and, regarding living beings as the sole source of asymmetric molecules, was strongly inclined to the belief that in the production of the active alcohol a living organism must have intervened. With characteristic energy he commenced the study of the lactic and alcoholic fermentations, the results of which (published in 1857 and 1860) were of such far-reaching and unexpected importance. The lactic organism—hitherto not only unknown but almost unsuspected—was discovered and shown to be the specific cause of the chemical change of sugar into lactic acid. In the same way he showed that living yeast was the cause of the alcoholic fermentation of sugar, and triumphed over the objections and arguments of Liebig by growing yeast in a synthetic medium, which contained only mineral salts and well-known pure stable organic substances. By this bold stroke Liebig's contention that the ferment was an unstable substance formed by the action of air on plant juices containing sugar was totally overthrown, and with it fell his theory of fermentation, according to which the instability of the ferment was transferred to the molecule of the sugar.

Pasteur, who had at once discovered that carbon dioxide and alcohol were not the only products of alcoholic fermentation, but that succinic acid and glycerol were always formed, in addition to the new-born cells of the organism, regarded fermentation as a physiological act by which the yeast acquired some material essential for its life from the fermented sugar. No

fermentation without life was his deliberate conclusion. He was not, however, heedless of the attempts made by Traube and others to attribute fermentation to the presence of ferments in the living cell, and we are told by Roux that he made many vain attempts by grinding, freezing, and plasmolysing yeast cells to obtain evidence as to the existence of such a ferment. It is strange to reflect that it was in all probability an unfortunate selection of a yeast unsuitable for the purpose of such experiments that led to these repeated failures, and that but for this he might have anticipated Buchner by a quarter of a century and have advanced one step further towards the elucidation of this complex problem.

Buchner's great discovery (1897) showed that Pasteur had gone too far in his generalisation. The act of fermentation was shown to be a chemical change produced in the presence of a non-living agent, separable from the cell, an agent the complexity of which still awaits complete resolution. It is the production of this essential instrument of change that is a function of the living cell, and the physiological significance of the act of fermentation is, in all probability, not the acquisition of material but of energy.

It was Pasteur's great achievement in these researches to have cleared the ground for future work. The old indefinite ideas were shown to be wrong and it was definitely proved that each different type of fermentation was due to a specific organism. Here the modern study of fermentation begins, and every worker on this subject must look back with gratitude to Pasteur's researches as the ultimate inspiration of his labours.

### Pasteur and the Fermentation Industries.

By Prof. A. R. LING.

LOUIS PASTEUR, one of the great figures in the scientific world of the nineteenth century—and there were giants in those days—was a man whose studies covered a more extensive range than those of perhaps any other scientific man of his time, while his researches have had a correspondingly far-reaching influence on both pure and applied science. Pre-eminently an academic worker, he was able to apply his discoveries to preventive medicine, surgery, agriculture, bacteriology, and the fermentation industries. Some of his later work was, indeed, actually taken up with a distinct practical objective. But the success achieved in his researches in applied science must be attributed solely to his profound studies in pure science, without which he would not have been in possession of the means of attacking problems in such a manner as to obtain results of direct benefit to mankind. In this connexion it may be pointed out that one of the

outstanding features of his genius was his remarkable prescience, which enabled him to turn purely academic work to utilitarian ends. As an example of the practical trend of his mind, his remarks in the preface to his celebrated "*Études sur la bière*" (English Translation) may be quoted:

"I am convinced," he says, "that I have found a precise, practical solution of the arduous problem which I proposed to myself. . . . These new studies are based on the same principles which guided me in my researches on wine, vinegar, and the silk-worm disease—principles, the application of which are practically unlimited. The etiology of contagious diseases may, perhaps, receive from them an unexpected light."

If we are to understand the causes which led to Pasteur's association with the fermentation industries, we must consider briefly his early work. It is an old tale, yet one worthy of repetition. From the College

of Arbois, he proceeded to Besançon and entered the *École Normale* in 1843. Here, as a student of chemistry, he came under the influence of Balard and of Dumas, while his attention was turned to crystallography by M. Delafosse, assistant to Haüy. When in 1844 Biot presented to the French Academy of Sciences a paper by Mitscherlich, in which it was stated that the sodium ammonium salts of racemic acid and of ordinary tartaric acid respectively were identical not only in chemical composition but also in crystalline form, Pasteur, who seems to have been guided by Sir John Herschel's discovery in 1820 of the opposite hemihedral relationship of dextro- and lævo-rock crystal or quartz, demonstrated to Biot's satisfaction that the crystals of sodium ammonium racemate also exhibited opposite hemihedrism. He was able, in fact, to separate by selection those crystals derived from ordinary dextro-tartaric acid and those derived from the hitherto unknown lævo-tartaric acid. Pasteur was, however, in the first place a chemist, and not long afterwards he discovered a chemical means of resolving racemic acid into its enantiomorphic isomerides by fractional crystallisation of its salts with certain optically active bases. This was followed later by a third, a biochemical method, which depended on the fact that the green mould *Penicillium glaucum*, when grown in the presence of racemic acid, ferments the dextro-acid preferably to the lævo-acid.

It is possible that this last-mentioned discovery was the means of leading Pasteur into the domain of biology, in which branch of science he was destined to make such brilliant discoveries. The commencement of his researches on yeast dates, however, from the year 1856, when he occupied the position of Dean of the Faculty of Science at Lille. Here he was consulted by a local distiller named Bigo on certain difficulties encountered in the manufacture of alcohol from beetroot.

Before describing Pasteur's final conclusions on the nature of yeast and of alcoholic fermentation, it will be necessary to take a brief retrospective glance on the state of our knowledge prior to the period with which we are dealing.

The cellular form of yeast had been established so long ago as the seventeenth century by Anton Van Leeuwenhoek, and in 1836 Cagniard-Latour observed that yeast cells are susceptible of reproduction by a sort of budding, while a similar observation was made about the same time by Schwann. Little account was taken of these observations, however, and alcoholic fermentation was explained by the theories of Berzelius and of Liebig, the former regarding it as a catalytic phenomenon, and the latter as one in which the ferment (yeast) was a substance which decomposed readily,

and in so doing set in motion the molecules of the fermentative matter.

In the year 1856, Pasteur commenced his studies on yeast and on alcoholic fermentation, and from that time dates his celebrated controversy with Liebig, which raged with fury up to the year 1861, when Pasteur had established anaerobic growth in certain micro-organisms, and had finally proved that yeast is a living organism. His further conclusion was that alcoholic fermentation is a phenomenon coterminous with the life of yeast. Still Liebig maintained his view tenaciously, and only modified it in 1870.

"It is possible," said Liebig, "that the only correlation between the physiological act and the phenomenon of fermentation is the production in the living cell of the substance which, by some special property analogous to that by which emulsin exerts a decomposing action on salicin and amygdalin, may bring about this decomposition of sugar into other organic molecules; the physiological act, in this view, would be necessary for the production of this substance, but it would have nothing else to do with fermentation." To this Pasteur replied, "Ici je ne contredirais encore pas."

Liebig's final hypothesis was therefore similar if not identical with that of Berzelius, and we shall now see how it was reconciled ultimately with the views of Pasteur. Berthelot in 1858 suggested that fermentation was the result of unorganised ferments (enzymes) secreted by the yeast, but to this Claude Bernard objected in 1860. Brefeld in 1874-75 considered that it was only when all the free oxygen in a fermentable liquid had been removed that the yeast cells commenced to excite fermentation, which he believed to be due to an enzyme. Pasteur in the course of his work had tried in vain to isolate this enzyme, and he favoured the view that fermentation was a vital act of the yeast cell. In 1897 E. Buchner extracted the enzyme of alcoholic fermentation from yeast and called it zymase.

Pasteur's further work on fermentation is embodied in his celebrated treatise, "*Études sur la bière*" (1876).

"Our misfortune," he says, "prompted me with the idea of these researches. I undertook them immediately after the war in 1870, and have since continued them without interruption, with the determination of perfecting them, and thereby benefiting a branch of industry wherein we are undoubtedly surpassed by Germany. I am convinced that I have formed a precise, practical solution of the arduous problem which I proposed to myself—that of a process of manufacture, independent of season and locality, which should obviate the necessity of having recourse to the costly methods of cooling employed in existing processes, and at the same time secure the preservation of its products for any length of time."

Pasteur's views on alcoholic fermentation are somewhat difficult to understand; hence he met with many

opponents to his theories. They may be summed up in his famous dictum—"Fermentation is life without air." He recognised, however, the necessity for the presence of dissolved oxygen in a liquid undergoing fermentation. Were it not, he says, for the oxygen which yeast meets with dissolved in the wort and also that which it seizes upon when manipulated in contact with air—for yeast which has been deprived for some time of free oxygen absorbs this gas with the greatest avidity—it would soon cease to act as a ferment. Pasteur, therefore, lays the greatest stress on the need for aëration as a preliminary to fermentation, and this was one of the most valuable of his suggestions relating to fermentation technology.

According to Pasteur, however, yeast is an amphibian living the aërobic life of an ordinary fungus, in which case in the presence of free aëration the maximum cell reproduction is obtained with a minimum of alcoholic fermentation or none at all, and secondly, as an anaërobie in which alcohol production is at its maximum together with a more limited cell repro-

duction. But in order to ensure both these results it is necessary for the yeast to have fixed a certain quantity of oxygen. It is impossible in the space at our disposal to deal with the work of Adrian Brown, of Horace Brown, and of A. Slator. The question is still in a sense in the melting-pot, but it would seem that Pasteur's views are likely to be proved to be in the main correct.

No better tribute could be paid to the services rendered by Pasteur to the fermentation industries than by quoting the words of Dr. Horace T. Brown.

"The current of my thoughts was entirely changed by the perusal of the early work of Pasteur, and when in 1867 . . . the celebrated 'Études sur le vin' came into my hands, I became thoroughly imbued with the new biological aspects of fermentation. There are probably but few here who can . . . fully realise what it meant to have the vague and utterly sterile ideas of the Liebig school replaced by the clear and logical demonstration that fermentations are phenomena correlative with the vital action of specific organisms."

### Centenary Celebrations.

THIRTY-ONE years ago, in the issue of NATURE for March 26, 1891 (vol. 43, p. 481), Sir James Paget contributed to our Scientific Worthy series an illuminating account of the career and scientific researches of Louis Pasteur. His son, Mr. Stephen Paget, in an article in the present supplement, makes clear the full meaning of Pasteur's work as the founder of bacteriology, and expresses the admiration of the scientific world for the fertile fields of study opened by him in many departments of natural knowledge. This and other contributions with which we have been favoured by Profs. Bulloch, Ledingham, Harden, Ling, and Dr. Tutton, will, we hope, be accepted as a modest tribute to the genius of an apostle of science and supreme benefactor of the human race.

The event, of course, which we desire to mark by the publication of this supplement is the centenary of Pasteur's birth at Dôle on December 27, 1822. The French Academy of Medicine will celebrate the centenary on December 26 by a special meeting, which will be addressed by several distinguished men of science. On the following day there will be a similar assembly at the Pasteur Institute, to which the Academy of Medicine will send representatives. In the United States of America the New York Academy of Medicine is organising an exhibition of books, manuscripts, pictures, and so on, illustrative of the life and work of Pasteur. The exhibition will be opened formally on December 27, when a number of distinguished American medical men will give addresses on various aspects of Pasteur's work. In Great Britain the Alliance Française is entertaining M. Valléry-Radot, descendants of Pasteur, in February, and Dr. Pasteur Valléry-Radot is to give an account of his grandfather's life and work.

Probably the most important event will be the great exhibition of hygiene and bacteriology which is being

organised by the town and University of Strasbourg, with the concurrence of the Pasteur Institute and the approval of the family of Pasteur. There, from May till October next, it is proposed to have exhibits illustrating the advances of science made as a result of Pasteur's far-reaching discoveries, while congresses for discussing questions relating to the prevention of disease will be held. It is hoped that it will be possible to preserve a section of the exhibition as a permanent Museum of Hygiene, principally for demonstrating the best methods of dealing with public water supplies and similar matters.

On the opening day of the exhibition there will be another interesting ceremony in the form of the unveiling of a monument to Pasteur which is being erected at the University of Strasbourg. The monument will be an obelisk carrying a medallion of Pasteur. It has been provided out of funds subscribed from many countries, towards which a committee under the presidency of Sir Charles Sherrington, president of the Royal Society, was able to forward a substantial contribution from this country. It is expected that a large and representative gathering from the scientific world will be present on the historic occasion of the unveiling ceremony.

The French Government will be represented at the various official celebrations. In addition, the Paris correspondent of the *Times* states that the president of the senatorial commission on education has announced that on the evening of December 27 the bells of Dôle, Pasteur's birthplace, will be rung for the two minutes preceding 5 o'clock, and that the bells of the Franche-Comté from the plain of the Saône to the crests of the Jura will reply. He has also suggested that all the bells in France should be rung at this time in commemoration of the great work for humanity accomplished during the past century.

## Recent Scientific and Technical Books

Volumes marked with an asterisk have been received at "NATURE" Office.

## Mathematics

- Boll, M.** Euclide, Galilée, Newton, Einstein. Gl. 8vo. Pp. 32. (Paris: Éditions d'actualité, 1922.) 1.50 francs.
- Bridgman, P. W.** Dimensional Analysis. Med. 8vo. Pp. v+112. (New Haven: Yale University Press; London: Oxford University Press, 1922.) 25s. net.\*
- Bryan, G. H.** Mathematical Tables. Med. 8vo. Pp. 28. (London: Macmillan and Co., Ltd., 1922.) 3s. 6d.\*
- Burns, P. F.** Reason-Why Arithmetic Course. Book 4. Large Cr. 8vo. Pp. 112. (London and Glasgow: Collins' Clear-Type Press, 1922.) Cloth, 9d.; paper, 8d.
- Chapman, E. H.** A General Text-Book of Elementary Algebra. Part 2. Cr. 8vo. Pp. iii+145+256+xxiii+xxxviii. (London, Glasgow and Bombay: Blackie and Son, Ltd., 1922.) 3s. 3d. net.
- Echaguibel, E. de.** Principios de análisis matemático: El problema fundamental del análisis. 8vo. Pp. 286. (Bilbao: Eléxpuru Hermanos, 1922.) 22 pesetas.
- Euler.** Introductio in analysin Infinitorum. Liber primus. Herausgegeben von A. Krazer and Fr. Rudio. (Leipzig und Berlin: B. G. Teubner, 1922.)
- Fawdry, R. C.** Elementary Experiments in Practical Mathematics. Demy 8vo. Pp. 61. (London: G. Bell and Sons, Ltd., 1922.) 1s. 4d.\*
- Galbrun, H.** Introduction à la théorie de la relativité, calcul différentiel absolu et géométrie. Roy. 8vo. Pp. x+458. (Paris: Gauthier-Villars et Cie, 1923.) 60 francs.\*
- Haas, A.** Vektoranalysis in ihren grundzügen und wichtigsten physikalischen Anwendungen. Roy. 8vo. Pp. vi+149. (Berlin und Leipzig: Walter de Gruyter und Co., 1922.) 80s.\*
- Henry, A.** Calculus and Probability for Actuarial Students. (Published by the Authority and on Behalf of the Institute of Actuaries.) Demy 8vo. Pp. vii+152. (London: C. and E. Layton, 1922.) 12s. 6d.\*
- Kennelly, A.-E.** Les Applications élémentaires des fonctions hyperboliques à la science de l'ingénieur électricien. Med. 8vo. Pp. viii+153. (Paris: Gauthier-Villars et Cie, 1922.) 15 francs.\*
- Loring, F. H.** Definition of Relativity. Demy 8vo. Pp. 16. (London: H. O. Lloyd and Co., 327 Upper Street, N.1., 1922.) 1s. net.
- Loring, F. H.** Definition of the Æther. Demy 8vo. Pp. 16. (London: H. O. Lloyd and Co., 327 Upper Street, N.1., 1922.) 1s. net.
- Loring, F. H.** Definition of Equivalence. Demy 8vo. Pp. 16. (London: H. O. Lloyd and Co., 327 Upper Street, N.1., 1922.) 1s. net.
- Muir, Sir T.** Note on a Theorem of Frobenius' connected with Invariant-Factors. (Proceedings of the Royal Society of Edinburgh, Session 1922-1923. Vol. 42, Part 3, No. 22.) Sup. Roy. 8vo. Pp. 342-347. (Edinburgh: R. Grant and Son; London: Williams and Norgate, 1922.) 1s.\*
- Myrberg.** Über Systeme analytischer Funktionen, welche ein Additionstheorem besitzen. (Leipzig und Berlin: B. G. Teubner, 1922.)
- Picard, E.** Traité d'analyse (Cours de la Faculté des Sciences). 3 vols. Roy. 8vo. Tome I: Intégrales simples et multiples—L'équation de Laplace et ses applications—Développement en séries—Applications géométriques du calcul infinitésimal. 3<sup>e</sup> édition, revue et corrigée. Pp. xvii+594. (Paris: Gauthier-Villars et Cie, 1922.) 45 francs.
- Ringue, R.** Tables de coefficients à l'usage des commerçants et des industriels. Cr. 8vo. Pp. 45. (Paris et Liège: Ch. Béranger, 1922.) 8 francs.
- Spurgeon, E. F.** Life Contingencies. (Published by the Authority and on Behalf of the Institute of Actuaries.) Demy 8vo. Pp. xxvii+477. (London: C. and E. Layton, 1922.) 30s.\*
- Stuyvaert, M.** Algèbre (premier degré) à l'usage des Écoles primaires, moyennes, normales, etc. 8vo. Pp. 117. (Gand: Van Rysselberghe et Rombaut, 1922.) 4.50 francs.

**Thirring, H.** Die Idee der Relativitätstheorie. Zweite, durchgesehene und verbesserte Auflage. Pp. iv+172. (Berlin: J. Springer, 1922.) 720 marks.

**Thomson, J. B.** An Experiment in Number-Teaching. Cr. 8vo. Pp. vii+86. (London: Longmans, Green and Co., 1922.) 2s. 6d.

**Tropfke, J.** Geschichte der Elementarmathematik in systematischer Darstellung, mit besonderer Berücksichtigung der Fachwörter. Zweite, verbesserte und sehr vermehrte Auflage. Dritter Band: Proportionen, Gleichungen. 8vo. Pp. iv+151. (Berlin und Leipzig: Walter de Gruyter und Co., 1922.) 60 marks.

**Watson, G. N.** A Treatise on the Theory of Bessel Functions. Imp. 8vo. Pp. viii+804. (Cambridge: At the University Press, 1922.) 70s. net.\*

**Wyckoff, R. W. G.** The Analytical Expression of the Results of the Theory of Space-Groups. (Publication 318.) Sup. Roy. 8vo. Pp. vii+180. (Washington: Carnegie Institution, 1922.) 3.25 dollars.\*

## Mechanics: Mechanical Engineering

**Aeronautical Research Committee.** Reports and Memoranda. No. 586: Report on various Airscrews. 3s. net. No. 717: Lateral Control at Low Speeds. 1s. 6d. net. No. 723: Aerofoil Theory. 9d. net. No. 728: Investigations of the Aerodynamic Properties of Wing Ailerons. Part 4: Effect of Yaw on the Balance of Ailerons of the "Horn" type. 1s. net. No. 741: Graphical Method for the Determination of the Bending Moments and Deflection in an Aeroplane Spar. 4d. net. No. 744: Theory of Initial Motions and its Application to the Aeroplane. 9d. net. No. 748: Acceleration Derivatives. 2d. net. No. 751: Stability of Airships. 4d. net. No. 756: Tail Loads in recovering from a Vertical Dive at Terminal Velocity. 1s. 6d. net. No. 757: Effect of Rate of Loading on the Apparent Strength of Cotton Balloon Fabric. 4d. net. No. 758: Viscosity of Acetyl Cellulose Solutions. 6d. net. Vibrations of Rat-wires. 1s. 6d. net. No. 760: Force of an Aileron balanced by the "Backward Hinge" Method. 2d. net. No. 762: Lift and Drag of B.E. 2e with R.A.F. 14 Wings. 4d. net. Lift and Drag of B.E. 2e with R.A.F. 19 Wings. 4d. net. No. 765: Rotational Inflow Factor in Propeller Theory. 3d. net. No. 766: Free Transverse Vibrations of Airscrew Blades. 3d. net. No. 768: Steady Adiabatic Flow of a Gas. 2d. net. No. 770: Drag Curve of R.A.F. 14 B.E. 2e Wings. 4d. net. No. 771: Experiments with a Modified Thrust-meter. 4d. net. No. 775: Accident to H.M. Airship R. 38. 1s. 3d. net. No. 777: Directional Hot-wire Anemometer. 6d. net. (London: H.M. Stationery Office, 1922.)

**Dommett, W. E.,** Edited by. Whittaker's Mechanical Engineers' Pocket-book. Third edition, entirely rewritten. Pott 8vo. Pp. xviii+776. (London: Sir I. Pitman and Sons, Ltd., 1922.) 12s. 6d. net.

**Duval, A.-B., et Hébrard, L.** Traité pratique de navigation aérienne. Med. 4to. Pp. 40. (Paris: Gauthier-Villars et Cie, 1922.) 6 francs.

**Hewett, B. H. M., and Johannesson, S.** Shield and Compressed Air Tunneling. Med. 8vo. Pp. x+465. (New York and London: McGraw-Hill Book Co., Inc., 1922.) 25s.\*

**Lafon, C.** Étude sur le ballon captif et les aérostats marins. Roy. 8vo. Pp. vi+206. (Paris: Gauthier-Villars et Cie, 1922.) 20 francs.\*

**Levy, L. A.** Gasworks Recorders: Their Construction and Use. Cr. 4to. Pp. xi+246. (London: Benn Bros., Ltd., 1922.) 35s. net.\*

**McLeod, J. R.** Practical Civil Engineering: Simplified for the Far East. Fcap. 8vo. Pp. 107. (London: Cecil Palmer, 1922.) 7s. net.

**Margoules, W.** Les Hélicoptères: Recherches expérimentales sur le fonctionnement le plus général des hélices: Études sur la mécanique de l'hélicoptère. Med. 8vo. Pp. xi+90. (Paris: Gauthier-Villars et Cie, 1922.) 10 francs.\*

**Motor Manual, The :** A Practical Handbook dealing with the Working Principles, Construction and Management of all Types of Motor Cars. Compiled and illustrated by the staff of the "Motor." Twenty-fourth edition, revised. Demy 8vo. Pp. 238. (London: Temple Press, Ltd., 1922.) 2s. 6d. net.

**Owen, G. A.** A Treatise on Weighing Machines: a Guide to the Principles underlying the Construction of Weighing Instruments. Med. 8vo. Pp. 214. (London: C. Griffin and Co., Ltd., 1922.) 12s. 6d. net.

**Podevyn, P.-A.** Traité de mécanique, à l'usage des ouvriers, dessinateurs et techniciens-mécaniciens. Fcap. 8vo. Pp. 160. (Paris: Libr. Desforges, 1922.) 7.50 francs.

**Wilson, F. R.** Railway Signalling: Automatic. (Pitman's Technical Primers.) Fcap. 8vo. Pp. 130. (London: Sir I. Pitman and Sons, Ltd., 1922.) 2s. 6d. net.

**Wilson, L. A., and Richards, C. R.** A Study of Air-Steam Mixtures. (Engineering Experiment Station, Bulletin No. 131.) Med. 8vo. Pp. 96+9 charts. (Urbana, Ill.: University of Illinois, 1922.) 75 cents.\*

## Physics: Electrical Engineering

**Ballhatchet, A. V.** Wireless Apparatus Making: a Practical Handbook on the Design, Construction, and Operation of Apparatus for the Reception of Wireless Messages. Cr. 8vo. Pp. 195. (London: P. Marshall and Co., 1922.) 3s. 6d. net.

**Borel, E.** L'Espace et le temps. (Nouvelle Collection Scientifique.) Fcap. 8vo. Pp. iv+246. (Paris: F. Alcan, 1922.) 4 francs.

**Brown, S. E.** Experimental Science. Part 3: Experimental Electricity and Magnetism. Cr. 8vo. Pp. vii+222. (Cambridge: At the University Press, 1922.) 5s.\*

**Coblentz, W. W.** Spectrophoto-electrical Sensitivity of Argenteite (Ag<sub>2</sub>S). (Scientific Papers of the Bureau of Standards, No. 416.) Sup. Roy. 8vo. Pp. 265-280. (Washington: Government Printing Office, 1922.) 5 cents.\*

**Crowther, J. A.** Practical Physics. Cr. 8vo. Pp. xxii+406. (London: H. Frowde and Hodder and Stoughton, 1922.) 10s. 6d. net.

**Dellinger, J. H., and Preston, J. L.** Properties of Electrical Insulating Materials of the Laminated Phenol-Methylene Type. (Technologic Papers of the Bureau of Standards, No. 216.) Sup. Roy. 8vo. Pp. 501-627. (Washington: Government Printing Office, 1922.) 30 cents.\*

**Department of Scientific and Industrial Research :** Food Investigation Board. Special Report No. 9 by the Engineering Committee of the Board. The Transmission of Heat by Radiation and Convection: Experiments by E. Griffiths and A. H. Davis. Roy. 8vo. Pp. iv+44. (London: H.M. Stationery Office, 1922.) 1s. 6d. net.\*

**Grainger, M. J.** Amateur Radio: How and Why of Wireless, with Complete Instructions on Operation of Receiving Outfits. Cr. 8vo. Pp. xii+166. (London: Eveleigh Nash and Grayson, Ltd., 1922.) 6s. net.

**Gregory, Sir R., and Hadley, H. E.** A Class Book of Physics. Parts 1, 2, 3, and 4: Fundamental Measurements, Hydrostatics and Mechanics, Heat, Light. Cr. 8vo. Pp. x+345. (London: Macmillan and Co., Ltd., 1922.) 4s. 6d.

**Hallows, R. W.** Wireless Telephony Simply Explained. (How Does it Work Series.) Cr. 8vo. Pp. 125. (London: C. Arthur Pearson, Ltd., 1922.) Cloth, 2s. 6d. net; paper, 1s. 6d. net.

**Johnson, B. K.** Practical Optics for the Laboratory and Workshop. Demy 8vo. Pp. 189. (London: Benn Bros. Ltd., 1922.) 12s. 6d. net.\*

**Karcher, J. C.** A Piezo-Electric Method for the Instantaneous Measurement of High Pressures. (Scientific Papers of the Bureau of Standards, No. 445.) Sup. Roy. 8vo. Pp. 257-264. (Washington: Government Printing Office, 1922.) 5 cents.\*

**Lowell, P. D.** Radio-Frequency Amplifiers. (Scientific Papers of the Bureau of Standards, No. 449.) Sup. Roy. 8vo. Pp. 335-343. (Washington: Government Printing Office, 1922.) 5 cents.\*

**Macdonald, K.** Macdonald's Tables for Correcting Wireless Bearings: from Latitude 5 deg. to 70 deg. North or South. Demy 8vo. Pp. 56. (Glasgow: J. Brown and Son, 1922.) 5s. net.

**Magnusson, C. E., Kalin, A., and Tolmie, J. R.** Electric Transients. Med. 8vo. Pp. viii+193. (New York and London: McGraw-Hill Book Co., Inc., 1922.) 12s. 6d.\*

**Marie, R.** Manuel pratique de l'apprenti et de l'amateur électricien. 4<sup>e</sup> partie: La traction électrique, Tramways et chemins de fer. (Bibliothèque des actualités industrielles, No. 123.) 2<sup>e</sup> édition. Cr. 8vo. Pp. 163. (Paris: Gauthier-Villars et Cie, 1922.)

**Meggers, W. F., Kiess, C. C., and Stimson, F. J.** Practical Spectrographic Analysis. (Scientific Papers of the Bureau of Standards, No. 444.) Sup. Roy. 8vo. Pp. 235-255. (Washington: Government Printing Office, 1922.) 10 cents.\*

**Meyer, O.** Elektrische Ofen. (Sammlung Göschen, Nr. 704.) Pp. 133. (Berlin und Leipzig: Walter de Gruyter und Co., 1922.)

**Peddie, W.** Colour Vision: a Discussion of the Leading Phenomena and their Physical Laws. Demy 8vo. Pp. xii+208. (London: E. Arnold and Co., 1922.) 12s. 6d. net.\*

**Reiche, F.** The Quantum Theory. Translated by H. S. Hatfield and H. L. Brose. Cr. 8vo. Pp. v+183. (London: Methuen and Co., Ltd., 1922.) 6s. net.\*

**Royal Society of Edinburgh.** Notes on a Correspondence between the French Academy of Sciences and the Royal Society of Edinburgh regarding the Invention of the Pilot Cable (Cable Guide); by the General Secretary. (Proceedings of the Royal Society of Edinburgh, Session 1922-1923. Vol. 42, Part 3, No. 23.) Sup. Roy. 8vo. Pp. 348-351. (Edinburgh: R. Grant and Son; London: Williams and Norgate, 1922.) 1s.\*

**Smith, C. F.** The Practical Testing of Dynamometers and Motors. Ninth edition. Demy 8vo. Pp. 271. (London: Scientific Publishing Co., 1922.) 7s. 6d. net.

**Taussig, C. W.** The Book of Radio: a Complete, Simple Explanation of Radio Reception and Transmission, including the outstanding features of Radio Service to the Public by Private and Government Agencies. Demy 8vo. Pp. xxxii+447. (London: D. Appleton and Co., 1922.) 16s. net.

## Chemistry

**Achalmé, Dr.** Les Édifices physico-chimiques. Tome II: La molécule, équilibres et réactions chimiques. 8vo. Pp. 232. (Paris: Payot et Cie, 1922.) 15 francs.

**Berthoud, A.** Les Nouvelles Conceptions de la matière et de l'atome. (Encyclopédie scientifique: Bibliothèque d'Histoire et de Philosophie des Sciences.) Gl. 8vo. Pp. v+314. (Paris: G. Doin, 1923.) 13.20 francs.\*

**Davis, W. A.** The Nature of the Changes occurring in the Indigo Steeping Vat, II. Trials made with the Time Control Test at Pusa and at different Factories in Bihar in 1921: The Factors determining Efficiency of Extraction and Purity of the resulting Indigo. (Agricultural Research Institute, Pusa: Indigo Publication, No. 11.) Cr. 4to. Pp. 81. (Calcutta: Government Printing Office, 1922.) 1.10 rupees.\*

**Diels, O.** Einführung in die anorganische experimentale Chemie. Roy. 8vo. Pp. 445. (Berlin und Leipzig: Walter de Gruyter und Co., 1922.)

**Ehrmann, E.** Traité des matières colorantes organiques et de leurs diverses applications. Roy. 8vo. Pp. xxiv+615. (Paris: Libr. Dunod, 1922.) 58 francs.

**Fresenius, T. W.** Anleitung zur chemischen Analyse des Weines. Dritte unter Mitwirkung von L. Grünhut gänzlich neubearbeitete Auflage von Eugen Borgmanns Anleitung zur Analyse des Weines. Pp. 184. (München und Wiesbaden: J. F. Bergmann, 1922.)

**Friedl, J. N.** Text-book of Inorganic Chemistry. Vol. 9, Part 1: Cobalt, Nickel, and the Elements of the Platinum Group. (Griffin's Scientific Text-Books.) Second edition, revised. Med. 8vo. Pp. 392. (London: C. Griffin and Co., Ltd., 1922.) 18s. net.

**Gibson, C. S.** The Chemistry of Dental Materials. Demy 8vo. Pp. 176. (London: Benn Bros., Ltd., 1922.) 12s. 6d. net.\*

- Gill, A. H.** A Short Handbook of Oil Analysis. Tenth edition, revised. 12mo. Pp. 223. (Philadelphia: J. B. Lippincott Co., 1922.) 2.50 dollars.
- Hewitt, J. T.** Synthetic Colouring Matters: Dye-stuffs derived from Pyridine, Quinoline, Acridine and Xanthene. (Monographs on Industrial Chemistry.) Demy 8vo. Pp. xi+405. (London: Longmans, Green and Co., 1922.) 14s. net.\*
- Jordan, L., and Swindells, F. E.** Decarburization of Ferro-chromium by Hydrogen. (Scientific Papers of the Bureau of Standards, No. 448.) Sup. Roy. 8vo. Pp. 327-334. (Washington: Government Printing Office, 1922.) 5 cents.\*
- Laurie, A. P.** Chemical Combination and Sir Alfred Ewing's Magnetic Atom. (Proceedings of the Royal Society of Edinburgh, Session 1921-1922. Vol. 42, Part 3, No. 24.) Sup. Roy. 8vo. Pp. 352-361. (Edinburgh: R. Grant and Son; London: Williams and Norgate, 1922.) 1s. 4d.\*
- Leimdörfer, J.** Kolloide Lösungen. Pp. 108+7 Tafeln. (Augsburg: H. Ziolkowsky, G.m.b.H., 1922.)
- Liddell, D. M.,** Editor-in-Chief. Handbook of Chemical Engineering. Prepared by a Staff of Specialists. 2 vols. Med. 8vo. Vol. 1. Pp. xi+517. Vol. 2. Pp. v+510-1008. (New York and London: McGraw-Hill Book Co., Inc., 1922.) 40s.\*
- Loring, F. H.** Definition of Isotopes. Demy 8vo. Pp. 20. (London: H. O. Lloyd and Co., 327 Upper Street, N.1., 1922.) 1s. net.
- Martin, G.** Industrial and Manufacturing Chemistry: a Practical Treatise. Part I: Organic. Second edition, revised. Roy. 8vo. Pp. 764. (London: C. Lockwood and Son, 1922.) 36s. net.
- Palmer, Prof. L. S.** Carotinoids and related Pigments: The Chromolipoids. (American Chemical Society Monograph, No. 9.) (New York: The Chemical Catalog Co., Inc., 1922.) 4.50 dollars.
- Pascal, P.** Synthèses et catalyses industrielles. 2<sup>e</sup> fascicule. 4to. Pp. 226. (Lille: G. Janny, 1922.)
- Schwarz, R.** La Chimie des complexes inorganiques. Adapté de l'allemand par A. Juhard. 8vo. Pp. viii+72. (Paris: Libra. Dunod, 1922.) 8 francs.
- Scott, W. W.,** Edited by. Standard Methods of Chemical Analysis. Third edition, revised and enlarged. Vols. 1 and 2. Roy. 8vo. Pp. 742+631. (London: C. Lockwood and Son, 1922.) 52s. 6d. net.
- Seyewetz, A.** Le Négatif en photographie. 2<sup>e</sup> édition, revue, corrigée et augmentée. (Encyclopédie scientifique: Bibliothèque de Photographie.) Gl. 8vo. Pp. viii+308. (Paris: G. Doin, 1923.) 14 francs.\*
- Snell, F. D.** Colorimetric Analysis. Ex. Cr. 8vo. Pp. 158. (London: C. Lockwood and Son, 1922.) 10s. 6d. net.
- Thalman, F.** Die Fette, Öle und Wachstern: Ihre Gewinnung und Eigenschaften. 4 neu bearbeitete Auflage. (Chemisch-technische Bibliothek, Band 83.) Pp. 392. (Wien und Leipzig: A. Hartleben, 1922.)
- Thorpe, Sir E.** A Dictionary of Applied Chemistry. Vol. 4: L-Oxydisilin. Revised and enlarged edition. Med. 8vo. Pp. viii+740. (London: Longmans, Green and Co., 1922.) 60s. net.\*
- Weyman, G.** Modern Gasworks Chemistry. Cr. 4to. Pp. x+184. (London: Benn Bros., Ltd., 1922.) 25s. net.\*
- Wiesler, K.** Die chemischen Grundstoffe. (Bücher der Naturwissenschaft, Band 8.) Pp. 126. (Leipzig: P. Reclam, jun., 1922.)
- Auflage, bearbeitet von C. v. d. Heide.** Pp. 96. (Stuttgart: E. Ulmer, 1922.) 50 marks.
- Bauer, O., and Deiss, E.** Probenahme und Analyse von Eisen und Stahl: Hand- und Hilfsbuch für Eisenhütten-Laboratorien. Zweite Auflage. Pp. 304. (Berlin: J. Springer, 1922.)
- Black, W. H.** Structural Steelwork. (Pitman's Technical Primers.) Fcap. 8vo. Pp. 112. (London: Sir I. Pitman and Sons, Ltd., 1922.) 2s. 6d. net.
- Blacker, J. F.** The A B C of English Salt-glaze Stoneware: From Dwight to Doulton. Med. 8vo. Pp. 243. (London: Stanley Paul and Co., 1922.) 15s. net.
- Booth, W. H.** Liquid Fuel and its Apparatus. (New York: E. P. Dutton and Co., 1922.) 4 dollars.
- Braun, K.** Die Seifenfabrikation. Zweite, neu bearbeitete Auflage. (Sammlung Götschen, Nr. 336.) (Berlin und Leipzig: Walter de Gruyter und Co., 1922.)
- Burton, W.** A General History of Porcelain. 2 vols. Pp. 204+228. (New York: Funk and Wagnall, 1922.) 30 dollars.
- Cabiac, G.** Cours pratique du mécanicien chauffeur. (Bibliothèque d'Enseignement technique et professionnel.) Gl. 8vo. Pp. 508. (Paris: G. Doin, 1922.) 16 francs.
- Castle, F.** Machine Construction and Drawing. New edition. Fcap. 4to. Pp. viii+289. (London: Macmillan and Co., Ltd., 1922.) 7s. 6d.\*
- Clarke, A.** Flavouring Materials: Natural and Synthetic. (Oxford Technical Publications.) Cr. 8vo. Pp. xxi+166. (London: H. Frowde and Hodder and Stoughton, 1922.) 8s. 6d. net.\*
- Cooke, J. H.** The Velvet and Corduroy Industry: a Brief Account of the various Processes connected with the Manufacture of Cotton Pile Goods. (Common Commodities and Industries.) Cr. 8vo. Pp. ix+116. (London: Sir I. Pitman and Sons, Ltd., 1922.) 3s. net.
- Fritsche, W.** Untersuchung der festen Brennstoffe mit besonderer Berücksichtigung ihrer flüchtigen Bestandteile. Pp. 99. (Essen: W. Girardet, 1922.)
- Gourlay, C.** The Construction of a House. Second edition, revised. Fcap. folio. (London: B. T. Batsford, Ltd., 1922.) 7s. 6d. net.
- Granjon, R., Roseberg, P., et Piette, M.** Éléments de soudure autogène par questions et réponses constituant l'A B C des connaissances techniques et pratiques en la matière, suivis de quelques problèmes courants de soudure autogène. 2<sup>e</sup> édition. Cr. 8vo. Pp. 272. (Paris: Publications de l'Acétylène et de la Soudure autogène, 1922.)
- Greene, J. A., and Perkin, F. M.** "Patent" Smokeless and Semi-smokeless Fuels. (Common Commodities and Industries.) Cr. 8vo. Pp. xi+116. (London: Sir I. Pitman and Sons, Ltd., 1922.) 3s. net.
- Grossmann, H.** Ausgewählte Vorträge und Schriften von Adolf Frank über Kalisalze, Kalkstickstoff, Moorkultur und Torfverwertung, Zellstoffgewinnung, Mosaikindustrie usw. Pp. 291. (Berlin: M. Krayn, 1922.) 200 marks.
- Grünwald, J.** Chemische Technologie der Emailrohmaterialien. Zweite Auflage. Pp. 274. (Berlin: J. Springer, 1922.)
- Hyde, J. H.** Lubrication and Lubricants: a Concise Treatment on the Theory and Practice of Lubrication; the Physical, Chemical, and Mechanical Properties and Testing of Liquid and Solid Lubricants; with Notes on Recent Developments and Examples from Practice; for Engineers, Chemists, and Students. (Pitman's Technical Primers.) Fcap. 8vo. Pp. x+114. (London: Sir I. Pitman and Sons, Ltd., 1922.) 2s. 6d. net.\*
- Jacquet, A.** Les Machines-outils servant au travail des métaux. Pp. 156. (Paris: Libra. Dunod, 1922.) 9.50 francs.
- Kempton, P. H. S.** The Industrial Applications of X-rays: an Introduction to the Apparatus and Methods used in the Production and Application of X-rays for the Examination of Materials and Structures; with many Examples from Practice. (Pitman's Technical Primers.) Fcap. 8vo. Pp. xiii+112. (London: Sir I. Pitman and Sons, Ltd., 1922.) 2s. 6d. net.\*
- Kendrick, A. F., and Tattersall, C. E. C.** Handwoven Carpets: Oriental and European. 2 vols. Demy 4to. Vol. 1. Pp. xi+198. Vol. 2. Pp. xi+205 plates. (London: Benn Bros., Ltd., 1922.) 105s. net.\*

## Technology

- Alves, R.** Die deutsche Kalkindustrie während des Krieges. Pp. 65. (Berlin: Verlag des Vereins Deutscher Kalkwerke, E.V., 1922.)
- Attwood, E. L.** Theoretical Naval Architecture. Cr. 8vo. Pp. xii+512. (London: Longmans, Green and Co., 1922.) 12s. 6d. net.
- Barker, A. F.** Woollen and Worsted Spinning. Cr. 8vo. Pp. xvi+344. (London: Cassell and Co., Ltd., 1922.) 12s. 6d. net.
- Barth, M.** Die Obstweibereitung mit besonderer Berücksichtigung der Beerenobstweine. 9 verbesserte

**Kessler, V.** Die Essigsäure, ihre Gewinnung und wirtschaftliche Bedeutung. Pp. 118. (Berlin: M. Krayn, 1922.)

**Lehner, S.** Die Kütte und Klebemittel: Ausführliche Anleitung zur Darstellung sämtlicher Kütte und Klebemittel für alle Zwecke. 9 vermehrte und verbesserte Auflage, neu bearbeitet von F. Wächter. (Chemisch-technische Bibliothek, Band 25.) Pp. 176. (Wien und Leipzig: A. Hartleben, 1922.)

**Levy, S. I.** Incandescent Lighting. (Pitman's Common Commodities and Industries.) Cr. 8vo. Pp. x+129. (London: Sir I. Pitman and Sons, Ltd., 1922.) 3s. net.\*

**Ligginson, E. W.** Vade-mecum de l'inventeur. 777 inventions à réaliser de haute importance industrielle. Version française, par J. Rousset (Bibliothèque des Monographies techniques). Méd. 8vo. Pp. vii+259. (Paris: Libr. Desforges, 1922.)

**Michel, J.** La Coloration des métaux. Nouvelle édition remaniée et augmentée. Fcap. 8vo. Pp. x+325. (Paris: Libr. Desforges, 1922.) 12 francs.

**Plucknett, F.** Introduction to the Theory and Practice of Boot and Shoe Manufacture. (Longman's Technical Handicraft Series.) Second impression. Demy 8vo. Pp. 336. (London: Longmans, Green and Co., 1922.) 7s. 6d. net.

**Scherer, R.** Die künstlichen Fussböden-, Wändebelege und Deckenverkleidungen. (Chemisch-technische Bibliothek, Band 300.) Pp. 248. (Wien und Leipzig: A. Hartleben, 1922.)

**Schwarz, R.** Feuerfeste und hochfeuerfeste Stoffe. 2 vermehrte Auflage. Pp. 52. (Sammlung Vieweg, Heft 43.) (Braunschweig: F. Vieweg und Sohn, 1922.)

**Stone, W.** The Mechanism of Lubrication: a Popular Explanation of the Principles of Lubrication as developed Mathematically by Reynolds and Michel, and employed by the latter in the Design of the well-known Michell Thrust and Journal Bearings. (Melbourne: "Industrial Australian and Mining Standard," 1922.) 2s. 9d.

**Thiele, L.** Die Fabrikation von Leim und Gelatine. 2 neu bearbeitete Auflage. (Bibliothek der ges. Technik, Band 274.) Pp. 189. (Leipzig: Dr. M. Jänecke, 1922.)

**Truelove, R. H.** Oils, Pigments, Paints, Varnishes, etc.: a Concise Treatise on the Manufacture, Properties, and Uses of Liquid Protective and Decorative Coatings and their Ingredients. (Pitman's Technical Primers.) Fcap. 8vo. Pp. x+114. (London: Sir I. Pitman and Sons, Ltd., 1922.) 2s. 6d. net.

**Wall, E. J.** Practical Color Photography. Ex. Cr. 8vo. Pp. vii+248. (Boston: American Photographic Publishing Co.; London: H. Greenwood and Co., Ltd., 1922.) 13s. 3d.\*

**Wells, P. A., and Hooper, J.** Modern Cabinet Work: Furniture and Fittings. Third edition, revised. Roy. 8vo. Pp. 398. (London: B. T. Batsford, Ltd., 1922.) 25s. net.

**Wernicke, F.** Die Herstellung der feuerfesten Baustoffe. Pp. 220. (Berlin: J. Springer, 1922.)

### Astronomy

**Barley, A. H.** The Drayson Problem: an Astronomical Survey of the Whole Question, in the Form of a Reply to a recent Article in the Journal of the British Astronomical Association entitled "The Draysonian Fallacy." Demy 8vo. Pp. xxiv+48. (Exeter: W. Pollard and Co., Ltd., 1922.) 1s. 6d.\*

**Mauder, E. W.** The Astronomy of the Bible: an Elementary Commentary on the Astronomical References of Holy Scripture. Fourth edition. Cr. 8vo. Pp. xvi+410. (London: The Epworth Press, 1922.) 5s. net.\*

**Moreux, Th.** Les autres mondes sont-ils habités? Fcap. 8vo. Pp. 150+8 planches. (Paris: G. Doin, 1923.) 5 francs.

**Plassmann, J.** Herausgegeben von. Hevelius: Handbuch für Freunde der Astronomie und kosmischen Physik. Large 8vo. Pp. xix+672. (Berlin: F. Dümmler, 1922.) 2100 marks.

### Meteorology

**Brooks, C. E. P.** The Evolution of Climate. Demy 8vo. Pp. 173. (London: Benn Bros., Ltd., 1922.) 8s. 6d. net.\*

**Hayford, J. F.** Effects of Winds and of Barometric Pressures on the Great Lakes. (Publication 317.) Sup. Roy. 8vo. Pp. v+133+16 plates. (Washington: Carnegie Institution, 1922.) 2.75 dollars.\*

**Royal Meteorological Society.** Bibliography of Meteorological Literature, prepared by the Royal Meteorological Society with the Collaboration of the Meteorological Office. No. 2. Roy. 8vo. Pp. 33-53. (London: Royal Meteorological Society, 1922.) 2s. 6d.\*

### Mineralogy

**Spence, H. S.** Talc and Soapstone in Canada. (No. 583.) Roy. 8vo. Pp. 85. (Ottawa: Department of Mines, Mines Branch, 1922.) \*

### Geology

**Case, E. C.** New Reptiles and Stegocephalians from the Upper Triassic of Western Texas. (Publication 321.) Méd. 4to. Pp. 84+14 plates. (Washington: Carnegie Institution, 1922.) 2 dollars.\*

**Fischer, H.** Die Wunder des Welteises. Pp. 108. (Berlin-Wilmersdorf: H. Paetel, G.m.b.H., 1922.)

**Geological Survey,** Memoirs of the England and Wales: Explanation of Sheet 255. The Geology of the Country around Beaconsfield. By R. L. Sherlock and A. H. Noble; with Contributions by J. Pringle. Roy. 8vo. Pp. iv+59. (Southampton: Ordnance Survey Office; London: E. Stanford, Ltd., 1922.) 2s. net.\*

**Sieberg, A.** Die Verbreitung der Erdbeben auf Grund neuerer makro- und mikroseismischer Beobachtungen und ihre Bedeutung für Fragen der Tektonik. Pp. 96. (Jena: G. Fischer, 1922.)

**Termier, P.** A la gloire de la terre: Souvenirs d'un géologue. 8vo. Pp. 425. (Paris: Nouvelle Libr. Nationale, 1922.) 15 francs.

**Thoms, G.** Einführung in die Geologie Nordwestdeutschlands. 8vo. Pp. 72. (Stuttgart: F. Enke, 1922.) 30 marks.

**Voigt, H.** Eis, ein Weltenbaustoff. Gemeinverständliche Einführung in Ph. Fauths Höhrigers Glazialkosmogonie (Welteislehre). 2 erweiterte und verbesserte Auflage. Large 8vo. Pp. xii+317. Atlas. 4to. Pp. vi+15 Doppeltafeln. (Berlin-Wilmersdorf: H. Paetel, G.m.b.H., 1922.) 135 marks.

### Geography: Travel

**Bourgeois, R., et Noirel, H.** Géodésie élémentaire. (Encyclopédie scientifique; Bibliothèque de Mathématiques appliquées.) 8vo. Pp. x+452. (Paris: G. Doin, 1922.)

**Brown, I.** Nights and Days on the Gypsy Trail: through Andalusia and on other Mediterranean Shores. Demy 8vo. Pp. 283. (London: Harper and Bros., 1922.) 12s. 6d. net.

**Campbell, M. R.** Guidebook of the Western United States. Part E: The Denver and Rio Grande Western Route. (Department of the Interior: United States Geological Survey, Bulletin 707.) Méd. 8vo. Pp. xi+266+96 plates+10 maps. (Washington: Government Printing Office, 1922.) 1 dollar.\*

**Cherry-Garrard, A.** The Worst Journey in the World: Antarctic, 1910-1913. 2 vols. Méd. 8vo. Vol. 1. Pp. lxiv+300+4+30 plates+4 maps. Vol. 2. Pp. viii+301+585+28 plates+1 map. (London, Bombay and Sydney: Constable and Co., Ltd., 1922.) 63s. net.\*

**Crawford, O. G. S.** The Andover District: an Account of Sheet 283 of the One-inch Ordnance Map (Small Sheet Series). (Oxford Geographical Studies.) Roy. 8vo. Pp. 99. (Oxford: Clarendon Press; London: Oxford University Press, 1922.) 7s. 6d. net.\*

**Elliott, L. E.** Chile: To-day and To-morrow. Ex. Cr. 8vo. Pp. x+340+plates. (New York: The Macmillan Co.; London: Macmillan and Co., Ltd., 1922.) 24s. net.\*

**Fenn, E. A. H.** Maps: How to Read and Make Them. Demy 16mo. Pp. 38. (Glasgow: J. Brown and Son, 1922.) 9d. net.



- Fletcher, G.**, Edited by. Ireland. (The Provinces of Ireland.) Cr. 8vo. Pp. xv+294. (Cambridge: At the University Press, 1922.) 8s. 6d. net.
- Gaunt, M.** Where the Twain Meet. Demy 8vo. Pp. xii+335. (London: J. Murray, 1922.) 15s. net.
- Graff, F. W. Up de.** Head-Hunters of the Amazon: Seven Years of Exploration and Adventure. Demy 8vo. Pp. 316. (London: Herbert Jenkins, Ltd., 1922.) 16s. net.
- Grant, W. A.** The Topography of Stane Street: a Critical Review of "The Stane Street" by Hilaire Belloc. Demy 8vo. Pp. 95. (London: John Long, Ltd., 1922.) 5s. net.\*
- Groll, M.** Kartenkunde. I: Die Projektionen. Zweite Auflage, neubearbeitet von O. Graf. (Sammlung Göschel, Nr. 30.) Pp. 150. (Berlin und Leipzig: Walter de Gruyter und Co., 1922.)
- Halbfass, W.** Die Seen der Erde: Morphometrie derjenigen mindestens ein Quadratkilometer grossen Seen für welche gesicherte Tiefenangaben vorliegen, nebst dem Versuch einer Zusammenstellung unserer sonstigen Kenntnisse über die Seen der Erde, mit besonderer Berücksichtigung der wichtigsten unter ihnen. (Ergänzungsheft, Nr. 185 zu Petermanns Mitteilungen.) 4to. Pp. vi+170. (Gotha: J. Perthes, 1922.)
- Harper, C. G.** On the Road in Holland: Notes and Impressions in the Quaint Country of Dykes and Canals. Med. 8vo. Pp. viii+266. (London: Cecil Palmer, 1922.) 15s. net.
- Howarth, O. J. R.** The World About Us: a Study in Geographical Environment. Cr. 8vo. Pp. 94. (London: Oxford University Press, 1922.) 2s. 6d. net.\*
- Lane, R. W.** The Peaks of Shala: a Record of Certain Wanderings among the Hill-Tribes of Albania. Med. 8vo. Pp. 224. (London: Chapman and Dodd, 1922.) 12s. 6d.
- Lay, E. J. S.** The Pupils' Class-Book of Geography: The Americas. Cr. 8vo. Pp. 176. (London: Macmillan and Co., Ltd., 1922.) 1s. 3d.\*
- Maugham, W. S.** On a Chinese Screen. Pott 4to. Pp. 237. (London: W. Heinemann, 1922.) 10s. 6d. net.
- Prey, A., Mainka, C., and Tams, E.** Einführung in die Geophysik. (Naturwissenschaftliche Monographien und Lehrbücher, Band 4.) Roy. 8vo. Pp. viii+340. (Berlin: J. Springer, 1922.) 12s. 6d.\*
- Reinhard, R.** Das neue Bild der Weltkarte (1922). 8vo. Pp. 16. (Breslau: F. Hirt, 1922.) 9 marks.
- Sabatier, C. Le Transsaharien.** 8vo. Pp. xii+206. (Paris: E. Larousse, 1922.)
- Teichman, E.** Travels of a Consular Officer in Eastern Tibet: together with a History of the Relations between China, Tibet, and India. Roy. 8vo. Pp. xxiv+248+64 plates+8 maps. (Cambridge: At the University Press, 1922.) 25s. net.\*
- Thomas, E.** Described by. Oxford. Painted by J. Fulleylove. Demy 8vo. Pp. 279. (London: A. and C. Black, Ltd., 1922.) 7s. 6d. net.
- Tuker, M. A. R.** Described by. Cambridge. Painted by W. Matthison. Demy 8vo. Pp. 230. (London: A. and C. Black, Ltd., 1922.) 7s. 6d. net.
- Verrill, A. H.** Islands and their Mysteries. Cr. 8vo. Pp. xv+232. (London: A. Melrose, Ltd., 1922.) 6s. net.
- Wenger, L.** Das Deutschtum in Kärnten. 8vo. Pp. 36. (München: F. A. Pfeiffer und Co., 1922.) 10 marks.
- Wilkinson, M.** The Dingbat of Arcady. Cr. 8vo. Pp. 188. (London: A. Melrose, Ltd., 1922.) 6s. net.

### General Biology: Natural History

- Bailey, V.** Beaver Habits, Beaver Control and Possibilities in Beaver Farming. (Department of Agriculture, Bulletin No. 1078.) Med. 8vo. Pp. 31+7 plates. (Washington: Government Printing Office, 1922.) 15 cents.\*
- Baitsell, G. A.**, Edited by. The Evolution of Man: a Series of Lectures delivered before the Yale Chapter of the Sigma Xi during the Academic Year 1921-1922. Med. 8vo. Pp. x+202. (New Haven: Yale University Press; London: Oxford University Press, 1922.) 15s. net.\*

**Cole, C. C.** Velvet Paws and Shiny Eyes: Adventures of a Little Boy in Nature's Wonderland—Among Furry Friends and Feathery. Cr. 8vo. Pp. vi+152. (London: Hodder and Stoughton, Ltd., 1922.) 3s. 6d. net.

**Coward, T. A.** Bird Haunts and Nature Memories. Ex. Cr. 8vo. Pp. ix+214+24 plates. (London and New York: F. Warne and Co., Ltd., 1922.) 7s. 6d. net.\*

**English, D.** A Book of Nimble Beasts: Bunny Rabbit, Squirrel, Toad, and "those sort of people." Cr. 8vo. Pp. 320. (London: Eveleigh Nash and Grayson, Ltd., 1922.) 6s. net.

**Firth, R. H.** Birds and Blossoms: a Calendar from Nature. Demy 4to. Pp. 32. (London: J. Bale, Sons, and Danielsson, Ltd., 1922.) 2s. 6d. net.

**Fisher, R. A.** On the Dominance Ratio. (Proceedings of the Royal Society of Edinburgh, Session 1922-1923. Vol. 42, Part 3, No. 21.) Sup. Roy. 8vo. Pp. 321-341. (Edinburgh: R. Grant and Son; London: Williams and Norgate, 1922.) 2s. 4d.\*

**Hudson, W. H.** A Hind in Richmond Park. 4to. Pp. xv+335. (London and Toronto: J. M. Dent and Sons, Ltd., 1922.) 16s. net.

**Menge, Dr. E. J.** General and Professional Biology with Special Reference to Man: including Introductory Embryology of the Chick and Frog, a brief Discussion of Mammalian Embryology, and Comparative Anatomy. Med. 8vo. Pp. 935. (Milwaukee, Wis.: The Bruce Publishing Co., 1922.) 6.50 dollars net.

**Moore, T. J.** Biology for Beginners. Cr. 8vo. Pp. x+558. (London, Calcutta and Sydney: G. G. Harrap and Co., Ltd., 1922.) 6s. net.\*

**Seton, E. T.** Wild Animals I have Known. 8vo. Pp. 360. (London: Hodder and Stoughton, Ltd., 1922.) 8s. 6d. net.

**Tegetmeier, W. B.** Pheasants: their Natural History and Practical Management. Edited, with an Introduction, by E. Parker. With a chapter on Diseases of Pheasants by H. H. Smith. Demy 8vo. Pp. xv+268. (London: The Field Press, Ltd., 1922.) 10s. 6d. net.

**Walter, H. E.** Genetics: an Introduction to the Study of Heredity. Revised edition. Cr. 8vo. Pp. xvi+354. (New York: The Macmillan Co.; London: Macmillan and Co., Ltd., 1922.) 10s. net.

### Botany: Horticulture: Forestry

**Bower, F. O.** The Primitive Spindle as a Fundamental Feature in the Embryology of Plants. (Proceedings of the Royal Society of Edinburgh, Session 1922-1923. Vol. 43, Part 1, No. 1.) Sup. Roy. 8vo. Pp. 30. (Edinburgh: R. Grant and Son; London: Williams and Norgate, 1922.) 4s.\*

**Buller, A. H. R.** Researches on Fungi. Vol. 2: Further Investigations upon the Production and Liberation of Spores in Hymenomycetes. Roy. 8vo. Pp. xii+492. (London: Longmans, Green and Co., 1922.) 25s. net.\*

**Cooper, W. S.** The Broad-Sclerophyll Vegetation of California: an Ecological Study of the Chaparral and its Related Communities. (Publication 319.) Sup. Roy. 8vo. Pp. 124+21 plates. (Washington: Carnegie Institution, 1922.) 2 dollars.\*

**Costantin, J., et Faideau, F.** Histoire naturelle illustrée. Tome 1: Les Plantes. 4to. Pp. 316+796 photographures+26 planches. (Paris: Libr. Larousse, 1922.) 50 francs.

**Hegi, G.** Alpenflora: Die verbreitetsten Alpenpflanzen von Bayern, Österreich und der Schweiz. 5 erweiterte Auflage. 8vo. Pp. 79. (München: J. F. Lehmann, 1922.) 180 marks.

**Lowson, J. M.** A Text-Book of Botany. Sixth edition. Gl. 8vo. Pp. viii+638. (London: University Tutorial Press, Ltd., 1922.) 9s. 6d.\*

### Zoology

**Birge, E. A., and Juday, C.** The Inland Lakes of Wisconsin: The Plankton. I. Its Quantity and Chemical Composition. (Bulletin No. 64, Scientific Series, No. 13.) Sup. Roy. 8vo. Pp. ix+222. (Madison, Wis.: Geological and Natural History Survey, 1922.)\*

**Boubier, M.** L'Oiseau et son milieu. (Bibliothèque de Philosophie scientifique.) Pott 8vo. (Paris: E. Flammarion, 1922.) 7.50 francs.

**British Museum.** A Guide to the Elephants (Recent and Fossil) exhibited in the Department of Geology and Palaeontology in the British Museum (Natural History), Cromwell Road, London, S.W.7. Second edition. Demy 8vo. Pp. iii+48. (London: British Museum (Natural History), 1922.) 1s.\*

**Cabrera, A.** Manual de Mastozoología. (Manuales Gallach, 120.) Pott 8vo. Pp. 440+12. (Madrid y Barcelona: Compañía Anónima Calpe, 1922.) 7 pesetas.\*

**Prenant, M.** Recherches sur le parenchyme des Plathelminthes: Essai d'histologie comparée. (Fasc. 5 des Archives de Morphologie générale et expérimentale.) 8vo. Pp. 174+10 planches. (Paris: G. Doin, 1922.) 22 francs.

**Sars, G. O.** An Account of the Crustacea of Norway: with Short Descriptions and Figures of all the Species. Vol. 9: Ostracoda. Parts 1 and 2: Cypridinidae, Conchoecidae, Polycopidae (part). Imp. 8vo. Pp. 32+16 plates. (Bergen: Bergen Museum; Christiania: Alb. Cammermeyers Forlag, 1922.) \*

**Stephenson, J.** On Some Scottish Oligochaeta, with a Note on Encystment in a Common Freshwater Oligochaete, *Lumbriculus variegatus* (Mull.). (Transactions of the Royal Society of Edinburgh, Vol. 53, Part 2, No. 14.) Roy. 4to. Pp. 277-295. (Edinburgh: R. Grant and Son; London: Williams and Norgate, 1922.) 3s.\*

**Vallois, V.** Les Transformations de la musculature de l'épisome chez les vertébrés. (Archives de morphologie générale et expérimentale.) 8vo. Pp. 538. (Paris: G. Doin, 1922.) 40 francs.

### Agriculture

**Chomley, C. H.** Australia: the Coming Cotton Country. Demy 8vo. Pp. 24. (London: "British Australasian," Ltd., 1922.) 4d.

**Davis, K. G.** Productive Farming. Fifth edition, revised and enlarged. Cr. 8vo. Pp. 540. (London: J. B. Lippincott Co., 1922.) 6s. net.

**Grange, H.** Wheat Costings, 1914 and 1919-1922: showing the Cost of Wheat Production in each Year, and a Method of Ascertaining the Cost of Corn-growing in any Year. Demy 8vo. Pp. 16. (London: P. S. King and Son, Ltd., 1922.) 1s. 6d.

**Hall, T. D.** Some Transvaal Soils. 1: Investigations on Some Highly Calcareous Soils; 2: Soils of the Eastern Transvaal Low Veld. (Department of Agriculture, Bulletin No. 5.) Roy. 8vo. Pp. 36. (Pretoria: Government Printing and Stationery Office, 1922.) 3d.\*

**Hedrick, U. P.** Cyclopedia of Hardy Fruits. Cr. 4to. Pp. x+370+16 plates. (New York: The Macmillan Co.; London: Macmillan and Co., Ltd., 1922.) 27s. net.\*

**Norris, R. V., Visvanath, B., and Kashinatha Ayyar, S.** A Soil Survey of the Godaveri Delta. (Department of Agriculture, Bulletin No. 83.) Roy. 8vo. Pp. 11+10 maps. (Madras: Government Press, 1922.) 2.12 rupees.\*

**Palmer, R., and Westell, W. P.** Pests of the Garden and Orchard, Farm and Forest: a Practical Guide for the Use of the Estate Owner, Farmer, Fruit Grower, and Gardener, concerning the Insects, Birds, and other Animals, Fungoid Diseases and Weeds, affecting Agriculture, Horticulture, and Forestry; together with Remedial and Preventive Measures. Roy. 8vo. Pp. 413+47 plates. (London: Henry J. Drane, 82a Farringdon Street, 1922.) 25s. net.\*

**Taylor, E. McK., and Burns, A. C.** The Basis of Egyptian Agriculture and its Relation to the Decline in the Average Yield per Feddan of Cotton. (Ministry of Agriculture, Egypt. Technical and Scientific Service, Bulletin No. 25.) Imp. 8vo. Pp. vi+70+4 plates. (Cairo: Government Publications Office, 1922.) P.T. 5.\*

**Thomson, M. R. H., Putterill, V. A., and Hobson, G.** Investigations on Export Citrus Fruit from South Africa during 1921. (Department of Agriculture: Bulletin No. 1.) Med. 8vo. Pp. 60+23 plates. (Pretoria: Government Printing and Stationery Office, 1922.) 1s. 6d.\*

**Wright, W. P.** A Book about Potatoes and other Vegetables. Cr. 8vo. Pp. 164. (London: Headley Bros., 1922.) 1s. net.

### Anatomy: Physiology

**Aron, M.** L'origine du sang dans le foie embryonnaire chez les mammifères. (Archives de morphologie générale et expérimentale.) 8vo. Pp. 128+5 planches. (Paris: G. Doin, 1922.) 15 francs.

**Berg, R.** Die Vitamine: Kritische Übersicht der Lehre von den Ergänzungsstoffen. Pp. 336. (Leipzig: S. Hirzel, 1922.)

**Beithen, A.** Volksernährung und Ersatzmittel. Pp. 562. (Leipzig: C. H. Tauchnitz, 1922.)

**Cathcart, E. P., Paton, D. N., and Pembrey, M. S.** Practical Physiology. Demy 8vo. Pp. xii+344+1 iv.+ 11 iii. (London: E. Arnold and Co., 1922.) 18s. net.\*

**Dakin, H. D.** Oxidations and Reductions in the Animal Body. (Monographs on Biochemistry.) Second edition. Roy. 8vo. Pp. ix+176. (London: Longmans, Green and Co., 1922.) 6s. net.\*

**Gerlach, V.,** Bearbeitet und herausgegeben von. Deutsches Nahrungsmittelbuch. Im Auftrage des Bundes Deutscher Nahrungsmittelfabrikanten und -Händler, E. V. 3 vielfach geänderte und vermehrte Auflage. Pp. 537. (Heidelberg: C. Winter, 1922.)

**Holt, L. E.** Food, Health and Growth: a Discussion of the Nutrition of Children. Cr. 8vo. Pp. xi+273. (New York: The Macmillan Co.; London: Macmillan and Co., Ltd., 1922.) 7s. 6d. net.\*

**Marshall, F. H. A.** The Physiology of Reproduction. Second and revised edition. Roy. 8vo. Pp. xvi+770. (London: Longmans, Green and Co., 1922.) 36s. net.\*

**Pirquet, Prof. C.** System of Nutrition. 16mo. Pp. 96. (Philadelphia: W. B. Saunders Co., 1922.) 2 dollars net.

**Short, A. R.** The New Physiology in Surgical and General Practice. Fifth edition, revised and enlarged. Cr. 8vo. Pp. 338. (Bristol: J. Wright and Sons, Ltd.; London: Simpkin, Marshall and Co., Ltd., 1922.) 9s. 6d. net.

### Anthropology: Ethnology

**Evans, J.** Magical Jewels of the Middle Ages and the Renaissance, particularly in England. Med. 8vo. Pp. 264. (Oxford: Clarendon Press; London: Oxford University Press, 1922.) 16s. net.\*

**Frazer, Sir J. G.** The Belief in Immortality and the Worship of the Dead. Vol. 2: The Belief among the Polynesians. Demy 8vo. Pp. ix+447. (London: Macmillan and Co., Ltd., 1922.) 18s. net.\*

**Peake, H.** The Bronze Age and the Celtic World. Demy 4to. Pp. 201+14 plates. (London: Benn Bros., Ltd., 1922.) 42s. net.\*

**Quennell, Marjorie and C. H. B.** Everyday Life in the New Stone, Bronze, and Early Iron Ages. (The Everyday Life Series, II.) Cr. 8vo. Pp. x+119. (London: B. T. Batsford, Ltd., 1922.) 5s. net.\*

**Stirke, D. W.** Barotseland: Eight Years among the Barots. Demy 8vo. Pp. xii+136. (London: J. Bale, Sons, and Danielsson, Ltd., 1922.) 21s. net.

**Werner, E. T. C.** Myths and Legends of China. Cr. 4to. Pp. 454. (London: G. G. Harrap and Co., Ltd., 1922.) 25s. net.

### Philosophy: Psychology

**Averill, L. A.** An Elementary Psychology for Teachers. (Riverside Textbooks in Education.) Cr. 8vo. Pp. xx+362. (London, Calcutta and Sydney: G. G. Harrap and Co., Ltd., 1922.) 7s. 6d. net.

**Bleuler, E.** Das autistisch-undisziplinierte Denken in der Medizin und seine Überwindung. Dritte Auflage. Unveränderter Neudruck. (Berlin: J. Springer, 1922.) 768 marks.

**Bon, G. le.** Psychologische Grundgesetze in der Völkerentwicklung. Aus dem Französischen von A. Seifhart. 8vo. Pp. vi+142. (Leipzig: S. Hirzel, 1922.) 70 marks.

**Bradley, F. H.** The Principles of Logic. 2 vols. Second edition, revised, with Commentary and Terminal Essays. Med. 8vo. Vol. I. Pp. xxviii+388. Vol. II. Pp. 389-738. (London: Oxford University Press, 1922.) 36s. net.

**Bumke, O.** Kultur und Entartung. Zweite, umgearbeitete Auflage. (Berlin: J. Springer, 1922.) 552 marks.

**Burkamp, W.** Die Kausalität des psychischen Prozesses und der unbewussten Aktionsregulationen. (Berlin: J. Springer, 1922.) 1120 marks.

**Coué, E.** Self-Mastery through Conscious Auto-Suggestion. Cr. 8vo. Pp. 92. (London: G. Allen and Unwin, Ltd., 1922.) 2s. 6d. net.

**Dunlap, K.** The Elements of Scientific Psychology. Sup. Roy. 8vo. Pp. 368. (London: H. Kimpton, 1922.) 18s. net.\*

**Elliot, H.** Human Character. Cr. 8vo. Pp. xvi+272. (London: Longmans, Green and Co., 1922.) 7s. 6d. net.\*

**Freud, S.** Group Psychology and the Analysis of the Ego. Authorised Translation by J. Strachey. (International Psycho-Analytical Library, No. 6.) Med. 8vo. Pp. v+134. (London and Vienna: The International Psycho-Analytical Press, 1922.) 7s. 6d. net.\*

**Hollingworth, H. L.** Judging Human Character. Demy 8vo. Pp. xiii+268. (London: D. Appleton and Co., 1922.) 7s. 6d. net.

**Hunt, H. E.** Spirit and Music. Cr. 8vo. Pp. 136. (London: Kegan Paul and Co., Ltd., 1922.) 3s. 6d. net.

**Kafka, G.** Herausgegeben von. Handbuch der vergleichenden Psychologie. 3 Bände. Roy. 8vo. Band 1: Die Entwicklungsstufen des Seelenlebens. Pp. vii+526. 3600 marks. Band 2: Die Funktionen des normalen Seelenlebens. Pp. viii+513. Band 3: Die Funktionen des abnormen Seelenlebens. Pp. viii+515. (München: E. Reinhardt, 1922.)

**Laing, B. M.** A Study in Moral Problems. 8vo. Pp. 279. (London: G. Allen and Unwin, Ltd., 1922.) 10s. 6d. net.

**Leighton, J. A.** Man and the Cosmos: an Introduction to Metaphysics. Demy 8vo. Pp. 589. (London: D. Appleton and Co., 1922.) 21s. net.

**MacDougall, R.** The General Problems of Psychology Conceptions. Demy 8vo. Pp. x+464. (New York: University Press, 1922.)

**Pierce, F.** Our Unconscious Mind: and How to Use It. Demy 8vo. Pp. xii+323. (London: Kegan Paul and Co., Ltd., 1922.) 10s. 6d. net.\*

**Pikler, J.** Theorie der Empfindungsqualität als Abbildes des Reizes. (Schriften zur Anpassungstheorie des Empfindungsvorganges, Heft 4.) 8vo. Pp. 108. (Leipzig: J. A. Barth, 1922.) 20 marks.

**Poppovich, N. M.** Die Lehre vom diskreten Raum in der neueren Philosophie. Sup. Roy. 8vo. Pp. ii+89. (Wien und Leipzig: W. Braumüller, 1922.)\*

**Richmond, W.** Philosophy and the Christian Experience: the Pringle Stewart Lectures for 1921-1922. Cr. 8vo. Pp. 96. (Oxford: B. Blackwell, 1922.) 3s. net.

**Rignano, E.** La Memoria biologica: Saggi di una nuova concezione filosofica della vita. 8vo. Pp. 250. (Bologna: N. Zanichelli, 1922.) 17,50 lire.

**Rougier, L.** La Structure des théories déductives: Théorie nouvelle de la déduction. (Bibliothèque de Philosophie contemporaine.) Fcap. 8vo. Pp. xv+136. (Paris: F. Alcan, 1922.) 7 francs.

**Whately-Smith, W.** The Measurement of Emotion. Demy 8vo. Pp. 184. (London: Kegan Paul and Co., Ltd., 1922.) 10s. 6d. net.

**Winternitz, S.** Relativitätstheorie und Erkenntnislehre. (Wissenschaft und Hypothese, Band 23.) (Leipzig und Berlin: E. G. Teubner, 1922.)

### Bacteriology: Hygiene

**Abbott, A. C.** The Principles of Bacteriology. Pp. 526. (Philadelphia: J. B. Lippincott Co., 1922.) 3.50 dollars.

**Greenish, H. G.** The Microscopical Examination of Foods and Drugs: a Practical Introduction to the Methods adopted in the Microscopical Examination of Foods and

Drugs, in the Entire, Crushed, and Powdered States. Third edition. Demy 8vo. Pp. xx+386. (London: J. and A. Churchill, 1922.) 18s. net.\*

**Greimer, K.** Handbuch des praktischen Desinfektors: Ein Leitfaden für den Unterricht und ein Nachschlagebuch für die Praxis. 2 vermehrte und verbesserte Auflage. Pp. 197+8 Tafeln. (Dresden und Leipzig: T. Steinkopff, 1922.) 45 marks.

**Hauduroy, P.** Atlas de parasitologie. 4to. Pp. 53+25 planches. (Paris: G. Doyn, 1923.) 12 francs.

**Maguire, L. C.** Vaccine and Serum Therapy in Veterinary Practice. Cr. 8vo. Pp. 135. (London: Baillière, Tindall and Cox, 1922.) 5s. net.

**Moore, C. G., and Partridge, W.** Bacteriology and Parasitology. Pp. 300. (New York: W. Wood and Co., 1922.) 1.75 dollars.

**Roy, L.** Hygiène industrielle: Les établissements classés: Leur nouvelle réglementation. 8vo. Pp. 200. (Paris: J.-B. Baillière et Fils, 1922.) 7 francs.

### Medicine: Surgery

**Arends, G.** Volkstümliche Namen der Arzneimittel, Drogen und Chemikalien. Neunte, verbesserte und vermehrte Auflage. Pp. 283. (Berlin: J. Springer, 1922.)

**Behnke's** Stammering, Cleft-Palate Speech, Lipping. Second edition, revised and enlarged, by K. Emil-Behnke. Cr. 8vo. Pp. vii+101. (London: Baillière, Tindall and Cox, 1922.) 3s. 6d. net.

**Biechele, M.** Anleitung zur Erkennung und Prüfung aller im Deutschen Arzneibuche, fünfte Ausgabe, aufgenommenen Arzneimittel mit Erläuterung der bei der Prüfung der chemischen Präparate sich abspielenden chemischen Prozesse. 14 neubearbeitete Auflage. Pp. 645. (Berlin: J. Springer, 1922.)

**Blomfield, J.** Anesthetics in Practice and Theory: a Text-Book for Practitioners and Students. Roy. 8vo. Pp. 436. (London: W. Heinemann (Medical Books) Ltd., 1922.) 25s. net.

**Bretonneau, P. F.** Traités de la dothinentérie et de la spécificité, publiés pour la première fois d'après les manuscrits originaux avec un avant-propos et des notes par L. Dubreuil-Chambardel. 8vo. Pp. 356. (Paris: Libr. Vigot, 1922.) 12 francs.

**Coleman, F.** Notes on Materia Medica, Pharmacology and Therapeutics for Dental Students and Practitioners. Fifth edition. (Oxford Medical Publications.) Cr. 8vo. Pp. xiv+308. (London: H. Frowde and Hodder and Stoughton, 1922.) 10s. 6d. net.

**Cowan, J., and Ritchie, W. T.** Diseases of the Heart. With a chapter on "The Ocular Manifestations of Arterial Disease," by A. J. Ballantyne. Second edition. Med. 8vo. Pp. xvi+605. (London: E. Arnold and Co., 1922.) 30s. net.

**Dejust, L.-H.** Examen critique de l'homœopathie (Un Chapitre d'histoire de la médecine). 8vo. Pp. 94. (Paris: Libr. Vigot, 1922.) 7 francs.

**Harris, I.** Diseases of the Heart: containing an Account of Clinical Electrocardiography. A Handbook for Students and Practitioners. Demy 8vo. Pp. viii+196. (London: Baillière, Tindall and Cox, 1922.) 10s. 6d. net.

**Hewitt, Sir H. W.** Anesthetics and their Administration: a Text-book. Fifth edition, edited by H. Robinson. (Oxford Medical Publications.) Med. 8vo. Pp. xiii+576. (London: H. Frowde and Hodder and Stoughton, 1922.) 30s. net.

**History of the Great War**, based on Official Documents. Medical Services: Surgery of the War. Vol. 2. Edited by Maj.-Gen. Sir W. G. Macpherson, Maj.-Gen. Sir A. A. Bowlby, Maj.-Gen. Sir C. Wallace, and Col. Sir C. English. Demy 8vo. Pp. vii+604+7 plates. (London: H.M. Stationery Office, 1922.) 25s. net.\*

**Keynes, G.** Blood Transfusion. (Oxford Medical Publications.) Demy 8vo. Pp. vii+166. (London: H. Frowde and Hodder and Stoughton, 1922.) 8s. 6d. net.\*

**Lecoq, R.** Les Maladies par carente. 8vo. Pp. 158. (Paris: Libr. Vigot, 1922.) 10 francs.

**McKay, W. J. S.** Lawson Tait, his Life and Work: a Contribution to the History of Abdominal Surgery and Gynaecology. Roy. 8vo. Pp. xii+578+24 plates. (London: Baillière, Tindall and Cox, 1922.) 25s. net.

**Maclean, H.** Modern Methods in the Diagnosis and Treatment of Glycosuria and Diabetes. Demy 8vo. Pp. xi + 159. (London, Bombay and Sydney: Constable and Co., Ltd., 1922.) 12s. net.

**Meara, F. S.** The Treatment of Acute Infectious Diseases. Second edition, revised. Roy. 8vo. Pp. ix + 806. (New York: The Macmillan Co.; London: Macmillan and Co., Ltd., 1922.) 31s. 6d. net.

**Medical Research Council.** Special Report Series. No. 67: Artificial Pneumothorax. (London: H.M. Stationery Office, 1922.) 2s. 6d. net.

**Metzger, J. A.** Principles and Practice of X-ray Technic for Diagnosis. Med. 8vo. Pp. 144. (London: H. Kimpton, 1922.) 14s. net.\*

**Mitchell, J. M.,** and others. Typhus Fever: with Special Reference to the Russian Epidemics. Demy 8vo. Pp. 48. (London: Baillière, Tindall and Cox, 1922.) 3s. 6d. net.

**Moliné, J.** Instruments et modes personnels de sémiologie et de thérapeutique otologiques. 8vo. Pp. 92. (Paris: A. Maloine et fils, 1922.)

**Niftrik, J.-G. van, et Demblon, A.** Le Danger des rayons-X et les moyens de protection. Roy. 8vo. Pp. 8. (Anvers: Libr. Adarix, 1922.) 3 francs.

**Paton, S.** Signs of Sanity, and the Principles of Mental Hygiene. Imp. 16mo. Pp. 241. (London: C. Scribner's Sons, 1922.) 7s. 6d. net.

**Rolleston, Sir H.** Some Medical Aspects of Old Age: being the Linacre Lecture, 1922, St. John's College, Cambridge. Cr. 8vo. Pp. ix + 170. (London: Macmillan and Co., Ltd., 1922.) 6s. net.

**Romanis, W. H. C.** Surgical Diagnosis. (Students' Synopsis Series.) Cr. 8vo. Pp. 308. (London: J. and A. Churchill, 1922.) 8s. 6d. net.

**Short, A. R.,** Edited by. An Index of Prognosis and End-results of Treatment. By various writers. Third edition, revised and enlarged. Roy. 8vo. Pp. 605. (Bristol: J. Wright and Sons, Ltd.; London: Simpkin, Marshall and Co., Ltd., 1922.) 42s. net.

**Stich, C.** Leitfaden für den pharmazeutischen Unterricht. Pp. 92. (Dresden and Leipzig: T. Steinkopff, 1922.)

**Teh, Wu Lien,** Edited by. North Manchurian Plague Prevention Service Reports, 1918-1922. Roy. 8vo. Pp. viii + 354. (Tientsin: Tientsin Press, Ltd., 1922.)

**Torriani, U. L.** Vegetazioni adenoidi adenoidismo. (Collezione Bardi di Attualità della Medicina.) Cr. 8vo. Pp. 92. (Roma: Dott. Giovanni Bardi, 1923.) 6 lire.\*

**Tredgold, A. F.** Mental Deficiency (Amentia). Fourth edition, revised and enlarged. Demy 8vo. Pp. xx + 569 + 30 plates. (London: Baillière, Tindall and Cox, 1922.) 21s. net.

**University of London:** Francis Galton Laboratory for National Eugenics. Eugenics Laboratory Memoirs, 21: The Treasury of Human Inheritance. Vol. 2: Anomalies and Diseases of the Eye. Nettleship Memorial Volume. Part 1: Retinitis Pigmentosa and Allied Diseases; Congenital Stationary Night-Blindness; Glioma Retinae; by Julia Bell; with a Memoir of Edward Nettleship, by J. B. Lawford. Roy. 4to. Pp. xv + 123 + 26 plates. (Cambridge: At the University Press, 1922.) 45s. net.\*

**Voronoff, S.** Grefies testiculaires. 8vo. Pp. 84 + 19 planches. (Paris: G. Doin, 1923.)

**Wilson, W.** A Handbook of Aural Surgery: for Students and Practitioners. Cr. 8vo. Pp. x + 336. (Manchester: Sherratt and Hughes, 1922.) 15s.

### Miscellaneous

**Braun, F.,** and **Præsent, H.** Systematische Bibliographie der wissenschaftliche Literatur Deutschlands 1914-21. Band I: Theoretische Wissenschaften. 8vo. Pp. xxiv + 391. (Berlin: Verlag Kniga, 1922.) 180 marks.

**Department of Commerce.** Circular of the Bureau of Standards, No. 24: Publications of the Bureau of Standards. Sixth edition. Sup. Roy. 8vo. Pp. 182. (Washington: Government Printing Office, 1922.)\*

**Department of Scientific and Industrial Research.** Report of the Committee of the Privy Council for Scientific and Industrial Research for the Year 1921-22. Roy. 8vo. Pp. iv + 123. (London: H.M. Stationery Office, 1922.) 3s. net.\*

**Development Commission.** Twelfth Report of the Development Commissioners for the Year ended the 31st March 1922. Roy. 8vo. Pp. v + 138. (London: H.M. Stationery Office, 1922.) 3s. 6d. net.\*

**Euler.** Neue Grundsätze der Artillerie. Aus dem Englischen des Herrn Benjamin Robins übersetzt und mit vielen Anmerkungen versehen. Mit 4 ballistische Abhandlungen herausgegeben von R. Scherrer. (Leipzig und Berlin: B. G. Teubner, 1922.)

**Evets, G.** The Administration and Finance of Gas Undertakings: with Special Reference to the Gas Regulation Act, 1920. Cr. 4to. Pp. xi + 374. (London: Benn Bros., Ltd., 1922.) 32s. 6d. net.\*

**Gladstone, H. S.** Record Bags and Shooting Records: together with some Account of the Evolution of the Sporting-Gun, Marksmanship, and the Speed and Weight of Birds. Demy 8vo. Pp. 240 + 12 plates. (London: H. F. and G. Witherby, 1922.) 15s. net.\*

**Hempelmann, A.** Betriebsverrechnung in der chemischen Grossindustrie. Pp. 107. (Berlin: J. Springer, 1922.)

**Liesegang, R. E.** Wissenschaftliche Forschungsberichte. Naturwissenschaftliche Reihe. (Dresden und Leipzig: T. Steinkopff, 1922.)

**Martindale, L.** The Woman Doctor: and Her Future. Med. 8vo. Pp. 196. (London: Mills and Boon, Ltd., 1922.) 7s. 6d. net.

**Mathews, W. H.** Mazes and Labyrinths: a General Account of their History and Development. Demy 8vo. Pp. xviii + 254. (London: Longmans, Green and Co., 1922.) 18s. net.\*

**Medical Research Council.** Reports of the Industrial Fatigue Research Board. No. 19: Two Contributions to the Study of Accident Causation. (General Series, No. 7.) Roy. 8vo. Pp. xi + 36. (London: H.M. Stationery Office, 1922.) 1s. 6d. net.\*

**Osborn, A. S.** The Problem of Proof especially as exemplified in Disputed Document Tricls: a Discussion of various Phases of the Proof of the Facts in a Court of Law, with some General Comments on the Conduct of Trials. Roy. 8vo. Pp. xxii + 526. (New York and Albany: Matthew Bender and Co., Inc., 1922.)\*

**Ostwald, W.** Die Welt der vernachlässigten Dimensionen. 7. und 8. Auflage. Pp. 253. (Dresden und Leipzig: T. Steinkopff, 1922.) 120 marks.

**Rijksuniversiteit te Leiden.** Het Natuurkundig Laboratorium der Rijksuniversiteit te Leiden in de Jaren 1904-1922. Gedenkboek aangeboden aan H. Kamerlingh Onnes, Directeur van het Laboratorium bij gelegenheid van zijn veertigjarig Professoraat op 11 November 1922. Sup. Roy. 8vo. Pp. iv + 458. (Leiden: Eduard Ijdo, 1922.)\*

**Royds, T. F.** The Eclogues, Bucolics, or Pastorals of Virgil. A revised Translation, with Introduction, Text, and Notes. Cr. 8vo. Pp. xiii + 121. (Oxford: Basil Blackwell, 1922.) 6s. net.\*

**Sampson, G.,** Selected and Edited by. Pages of Science. (Methuen's English Classics.) Fcap. 8vo. Pp. viii + 147. (London: Methuen and Co., Ltd., 1922.) 2s.\*

**Smith, A. F.** English Church Architecture of the Middle Ages: an Elementary Handbook. Cr. 8vo. Pp. 83 + 12 plates. (London: T. Fisher Unwin, 1922.) 5s. net.\*

**Unwin, E. E.** Religion and Biology. (Christian Revolution Series, No. 15.) Cr. 8vo. Pp. 185. (London: The Swarthmore Press, Ltd.; New York: George H. Doran Co., 1922.) 6s. net.\*

**Wells, H. G.** A Short History of the World. Cr. 4to. Pp. xv + 432. (London: Cassell and Co., Ltd., 1922.) 15s. net.\*

**Wood, E.,** Edited by. The Outdoor Boy. (The Modern Boy's Library.) Cr. 8vo. Pp. 280. (London: Cassell and Co., Ltd., 1922.) 5s. net.\*

**“EDNEY”**  
**THERMOGRAPHS & HYGROGRAPHS**  
 FOR INDUSTRIAL AND METEOROLOGICAL PURPOSES.

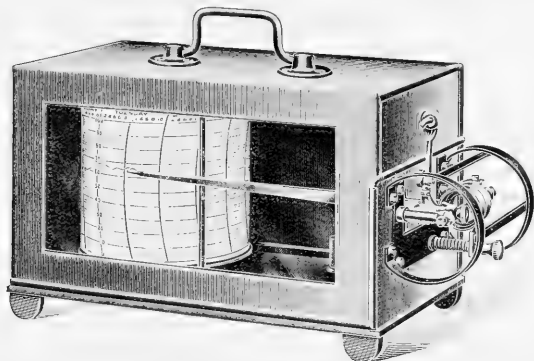

**NEW PATTERN “EDNEY” THERMOGRAPH**, with pen worked directly off the thermometric coil. Range 0-120 or 30-150 F., mounted on strong metal base, with copper cover, and complete with charts for one year, £7.

*See Editorial Notice “NATURE,” July 8, page 52.*

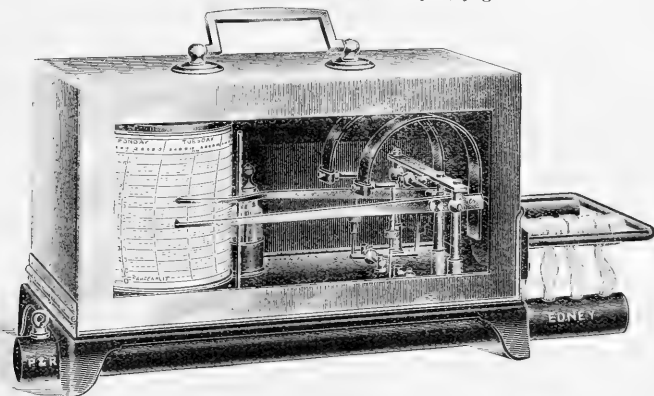

**IMPROVED “EDNEY” MERCURIAL HYGROGRAPH**, giving exact wet and dry bulb readings. Range 0-120 or 30-150 F., or to order. Mounted on strong cast-iron base, with copper cover, complete with charts for one year, £16:16s.

New Illustrated Descriptive List of above and other patterns of Thermographs and Hygrographs.  
 post free from the Sole Manufacturers :

## PASTORELLI & RAPKIN LTD.

Established 1750. Contractors to various Departments of H.M. Government.

Actual Makers also of Thermometers, Barometers, Barographs, Hydrometers, and Standard Meteorological Instruments.

**46 HATTON GARDEN, LONDON, E.C.1.**

*Any instrument sent on approval if desired.*

Carriage paid and safe delivery guaranteed of all Instruments within the United Kingdom.

## LABORATORY GLASSWARE

BEAKERS, FLASKS,  
RETORTS, etc.

## Porcelain

CRUCIBLES AND BASINS

## Filter Papers

## Pure Chemicals

JOHN J. GRIFFIN & SONS,  
LIMITED,

KEMBLE STREET, KINGSWAY,  
LONDON, W.C.2.

## THE FERGUSON SOLAR CHRONOMETER

will show correct time without any calculation or allowance for equation. It is very portable (Model A being only 4 ins. in diameter) and it can be set up by anybody, no compass or level being wanted.

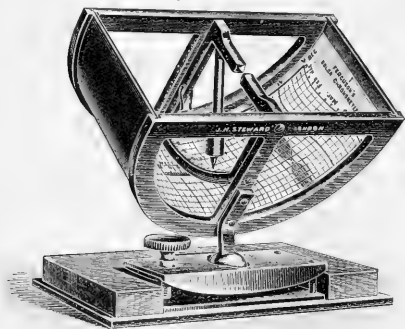

Model A, for use between 60° N. and 60° S. . . £5 15 0  
Model B, for use in any latitude . . . . . £6 15 0

With descriptive pamphlet.

**J. H. STEWARD, Ltd.,**

Opticians and Scientific Instrument Makers to the British  
and Foreign Governments.

406 & 457 STRAND, LONDON, W.C.2.

ESTABLISHED 1852.

## BELLINGHAM-STANLEY

*Polarimeter Tubes.*

*Cover Glasses. Washers.*

*Cementless Jacketed Tubes for high  
temperature work.*

*Mercury Lamps.*

*Spectroscopic Attachments.*

*Optical Trains for ultra-violet  
polarimetry.*

*Full particulars from*

*BELLINGHAM & STANLEY Ltd.*

*71 HORNSEY RISE,*

*LONDON, N.19.*

*Tel. Hornsey 2270.*

## Leitz

### MICROSCOPES & ACCESSORIES

*The following NEW CATALOGUES  
will be supplied on application:—*

46 B—Metallurgical  
Apparatus.

46 C—Dissecting Micro-  
scopes and Lenses.

47 E—Haematological  
Apparatus.

47 F—Microtomes.

47 Pol—Petrological  
Microscopes.

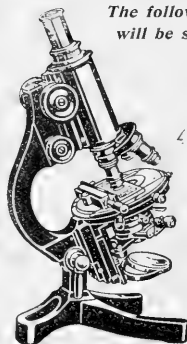

Stand AA

## OGILVY & CO.

British Agents for E. Leitz,

18 BLOOMSBURY SQUARE, LONDON, W.C.1.

*Optical and Mechanical Repairs to any make of  
Microscopical Apparatus executed on the Premises.*

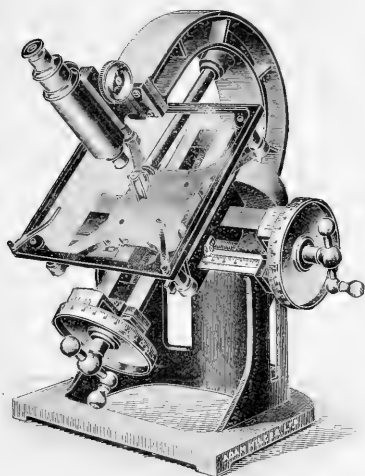

## CROSS SLIDE PHOTO-MEASURING MICROMETER

(Additional New Model)

*Full particulars of Photo-measuring  
Micrometers post free on application to*

**ADAM HILGER Ltd.,**  
75a Camden Road, London, N.W.1  
(Entrance : 24 Rochester Place—adjoining)

Telephone Numbers : NORTH 1677-8.  
Telegraphic Address : "SPHERICITY, PHONE, LONDON."

If the bonuses just declared continue uninterruptedly an assurance at death will be doubled after 37 years and trebled after 55 years. An assurance of £1,000 costs £27 or £34 a year to men aged 30 or 40 next birthday respectively.

## Equitable Life Assurance Society

Mansion House Street, London, E.C.2.  
W. Palin Elderton, Actuary and Manager.

No Shareholders

No Commission

## ZEISS REFRACTOMETERS

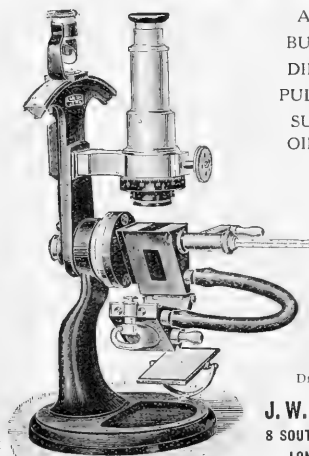

ABBE  
BUTTER  
DIPPING  
PULFRICH  
SUGAR,  
OIL, Etc.

ALL  
FROM  
LONDON  
STOCK



DISTRIBUTORS

**J. W. ATHA & CO.,**  
8 SOUTHAMPTON ROW,  
LONDON, W.C.1.

Prof. Taylor Jones'  
ELECTROSTATIC  
OSCILLOGRAPH  
FOR POTENTIALS UP TO  
250,000 VOLTS.

Dr. Owen's  
GOLD-LEAF  
ELECTROSCOPE

As shown at the Physical  
Society's last Exhibition.

Full particulars on application to the Sole Makers:

The Cox-Cavendish Electrical Co. Ltd.  
TWYFORD ABBEY WORKS,  
HARLESDEN, LONDON, N.W. 10.

SECOND-HAND ZEISS MICROSCOPES

ALL IN PERFECT CONDITION.

- IC Photo-micrographic Stand, revolving and centring stage, achrom. condenser, rack substage, 3 eyepieces, objectives A and E, and plankton searcher, objective changer with 4 slides, eyepiece and stage micrometers £30 0 0
- IV A Stand, mechanical stage and spare revolving vulcanite stage, racking substage with swing-out Abbe and Iris, 2 eyepieces, triple nose-piece, A and D objectives £30 0 0
- IV A Stand, spiral substage with Abbe condenser, 2 eyepieces, triple nose-piece objectives A and D (Zeiss) and  $\frac{1}{2}$  o.i. Watson £27 10 0
- I A Stand, revolving mechanical stage and extra vulcanite stage, racking substage, Abbe condenser, 2 eyepieces, A and C objectives £27 10 0
- 2 mm. Apo. Objective, 1.30 N.A., 160 mm. tube length £15 0 0
- Abbe Camera Lucida £2 10 0

Many others by all makers; list on application.

CLARKSON'S, 338 High Holborn, London, W.C.1.  
Opposite Gray's Inn Road. (The Original Firm.) Phone: Holborn 2149.

W. OTTWAY & Co. Ltd.

(Established 1640)

MANUFACTURERS

of all types of Astronomical,  
Surveying, Scientific and  
Optical Instruments.

Illustrated Leaflets post free.

We shall be pleased to give  
quotations for Refractor Tele-  
scopes up to 8 inches aperture,  
fully equipped on Equatorial.  
Silvering, Overhauling, Repairing & Adjusting done cheaply.



Orion Works, Ealing, London, W.5.

OXYGEN

And other Gases.

The British Oxygen Co. have works for the production  
of Oxygen, Nitrogen, Carbonic Acid, Nitrous Oxide,  
Hydrogen, and Argon in all chief industrial centres.  
The Company's Plants are capable of an aggregate out-  
put of about three million cubic feet per day.

Special Terms quoted to the Trade.

Catalogue and full particulars on application to the Head  
Offices of the Company—

THE BRITISH OXYGEN CO., Ltd.,  
ANGEL ROAD, UPPER EDMONTON,  
LONDON, N.18.

OLD PLATINUM, GOLD

Dental Alloy, Scrap, &c.,  
Purchased for Cash or Valued.

SPINK & SON, Ltd.,

17 & 18 PICCADILLY, LONDON, W.1.  
EST. 1772.

Fine Jewels or Plate also purchased or valued.

SCIENTIFIC APPLIANCES

DALE & HOLLINS

Electrical, Magnetic, Optical Materials and Apparatus, Dynamos,  
Motors, Insulated Wires, Batteries, Relays, WIRELESS RADIO  
Parts and Fittings, Crystals, Valves, Phones, Condensers, New  
Duros Accumulators, do not wear out, Electric Clocks, many  
new articles. *New List free.*  
Lenses, Prisms, Mirrors, and all Artists' Materials and  
Drawing Instruments. Large stock of good Second-hand  
Electrical and Scientific Instruments. *Full Illustrated List*  
6d. post free. See our showroom and windows, or write us. In centre of  
London—Top of Kingsway.

SCIENTIFIC APPLIANCES, 11 & 29 SICILIAN AVENUE, LONDON, W.C.1.

A DICTIONARY OF APPLIED PHYSICS

Edited by SIR RICHARD GLAZEBROOK, K.C.B., D.Sc., F.R.S.

In 5 Vols. Medium 8vo. Fully Illustrated. £3:3s. net each. Orders for the complete set of five volumes will be  
accepted through a bookseller at the price of £14:14s. net, payable in advance.

- Vol. I. MECHANICS ENGINEERING—HEAT. [Ready.]  
" II. ELECTRICITY. [Ready.]  
" III. METEOROLOGY, METROLOGY, and  
MEASURING APPARATUS.

- Vol. IV. OPTICS, SOUND, and RADI-  
OLOGY.  
" V. METALLURGY and AERO-  
NAUTICS.

ENGINEERING.—"In this dictionary, the history of discovery and the explanation of observed phenomena go  
hand-in-hand, new facts are detailed and their relation to the old are emphasised, new avenues of exploration are suggested,  
and we are invited to live in company with the successful men to whom has been granted the great privilege of achievement."

\* Full descriptive Prospectus post free on application.

MACMILLAN & CO., LTD., LONDON, W.C.2.



**SUPPORT BRITISH INDUSTRIES.**—By doing this you not only help your country, but in this case you buy the best in the cheapest market.

**OIL IMM.  $\frac{1}{12}$  OBJECTIVE**

**N.A. 1.30**, complete in brass case,

**£5.5.0**

SENT ON APPROVAL

AGAINST DEPOSIT.

$\frac{1}{8}$ -IN., OF SAME MODEL — **£2.0.0**

$\frac{1}{12}$  O.I. by Swift, Beck, Watson, or Leitz, **£5 5 0**

$\frac{1}{6}$  by Swift, Baker, Beck, or Watson, **£1 15 0**

**BROADHURST, CLARKSON & CO.,**  
MANUFACTURING OPTICIANS, MAKERS OF MICROSCOPICAL AND ASTRONOMICAL LENSES,  
63 Farringdon Road, London, E.C.1

*Grainless Photography. Filmless Photography.*

**RHEINBERG'S**

**STAGE MICROMETERS AND EYEPiece MICROMETERS**

New Stage Micrometer, 2 mm in 200 parts, numbered.

Chessboard Eyepiece Micrometers.

From all Leading Optical Firms.

**RHEINBERG & Co., 57-60 Holborn Viaduct, London, E.C. 1.**

Stock list of standard articles on application.

**MARINE BIOLOGICAL ASSOCIATION OF THE UNITED KINGDOM. THE LABORATORY, PLYMOUTH.**

The following animals can always be supplied, either living or preserved by the best methods:—

Sycon; Clava, Obelia, Sertularia; Actinia, Tealia, Caryophyllia, Alcyonium; Hormiphora (preserved); Leptoplana; Lineus, Amphiporus, Nereis, Aphrodite, Arenicola, Lanice, Terebella; Lepas, Balanus, Gammarus Ligia Mysis, Nebalia, Carcinus; Patella, Buccinum, Eledone, Pectens Bugula, Crisia, Pedicellina, Holothuria, Asterias, Echinus, Salpa (preserved), Scyllium, Raia, &c., &c.

For prices and more detailed lists apply to Biological Laboratory, Plymouth.

THE DIRECTOR.

**RADIUM ON HIRE**

(Activity 1,800,000).

**RADIUM MICROSCOPES,**

Complete with Radium, 2/6 and 7/6 each.

These are **SELF-LUMINOUS** in the dark, showing splendid Scintillations.

Pitchblende Scintilloscopes . . . . . 7/6 each.  
Extra Screens for Testing Minerals . . . . . 1/6 each.

**F. HARRISON GLEW,**

156 Clapham Road, London, S.W.9.

Telephones: 1787 Hop and 3117 Hop.

*X-Rays Limited*

J. W. MASON

Managing Director.

Incorporating the HIGH TENSION COMPANY.

DESIGNERS AND MANUFACTURERS OF

**TRANSFORMERS, INDUCTION COILS, VACUUM TUBES, etc.**

11 Torrington Place,  
Gower Street, London, W.C.1.

Telephone: MUSEUM 8121 (3 lines).

**NOTICE.**

The charges for Subscriptions to "NATURE" are:

	British Isles.			Abroad.		
	£	s.	d.	£	s.	d.
Yearly . . . . .	2	12	0	2	17	0
Half-yearly (26 Nos.) . . . . .	1	6	0	1	10	0
Quarterly (13 Nos.) . . . . .			13 0			16 0

Including the Two Half-Yearly Indexes and all Supplements.

The Advertisement rates are:

	£	s.	d.
Page . . . . .	8	8	0
Half-page . . . . .	4	8	0
Quarter-page . . . . .	2	6	0
Eighth-page . . . . .	1	4	0
Sixteenth-page . . . . .			12 6

Special Rates for Series upon Application.

The charges for Official Advertisements and "smalls" are 2s. 6d. for the first two lines in column, and 9d. each additional line. The sum of 6d. is charged for the re-direction of replies to advertisements with a Box No.

\*. Advertisements should reach the Publishers by the Saturday prior to the issue in which they are to appear.

**MACMILLAN & CO., LTD., St. Martin's Street, London, W.C.2.**

## THE BECK HIGH-POWER BINOCULAR

(Patent)

Not only an advance on previous Binoculars, but better than a Monocular with all powers.

1. Resolution equal to that of a Monocular.
2. Equal illumination in both eyes.
3. Short tube length, making Microscope compact.
4. No special object-glasses or eyepieces required.
5. Standard angle of convergence.
6. Binocular vision, saving eyestrain and giving better results than Monocular vision.
7. Converted into a Monocular by a touch.

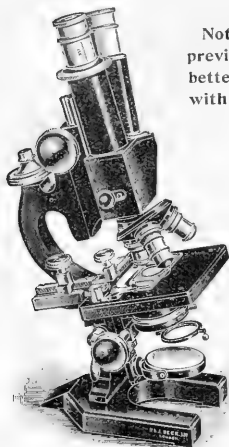

Full descriptive Price List on application.

R. & J. BECK, LTD., 68 CORNHILL, LONDON, E.C.3.

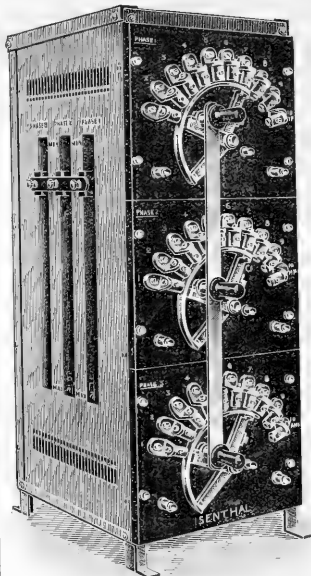

LABORATORY RESISTANCES  
ISENTHAL & CO. LTD.

Constructors in the Admiralty, War Office, India Office, Colonial Office, Postmaster-General, &c.  
Denzil Works, Willesden, London, N.W.10.

## RESEARCH MICROSCOPES.

The Microscope used in routine laboratory work must be capable of showing known structure, but the research worker who is trying to elucidate a problem, or to discover causes, must never be in the position of feeling that if he had something better he might succeed.

A "Research" Microscope, therefore, must have every refinement and advantage that the stand and lens can give him.

Watson's "Van Heurck" Microscope has been the instrument par excellence for many years, and has been, and is being used in all parts of the world for microscopical research and high power photo-micrographic work.

The Substage has a Fine Adjustment, so that the modern and very necessary Oil Immersion Condenser can be as fully focused as the Objective. Delicate adjustments are available for varying thicknesses of cover glasses.

The Stage rotates concentrically and has mechanical movements. The whole instrument is built on solid lines equal to a one-piece casting. It is framed, fitted and finished by hand in the only shop in the world where such work is done to-day.

### WATSON'S HIGH BARNET WORKS.

Full particulars of Watson's "Van Heurck" Microscopes are contained in their Catalogue of Microscopes, post free on request.

**W. WATSON & SONS, LTD.,**  
313 High Holborn, London, W.C.

ESTABLISHED 1837.

WORKS: BELLS HILL, HIGH BARNET.

A few of the many advantageous features of

## SPENCER MICROSCOPES

1. Automatically lubricated fine adjustment bearings.
2. Black lacquered body tubes, avoiding reflection of light into eyes of user.
3. Low compact construction (considerably lower than others), which affords greater ease and comfort in using.
4. Low position of the fine adjustment, head away from the mouth and breath of the user.
5. Extra large stages with unusual distance from optical axis to base of the arm.

Spencer Microscopes represent careful attention to the little things which generally escape attention.

**STANDLEY BELCHER & MASON, Ltd., Church Street, BIRMINGHAM.**







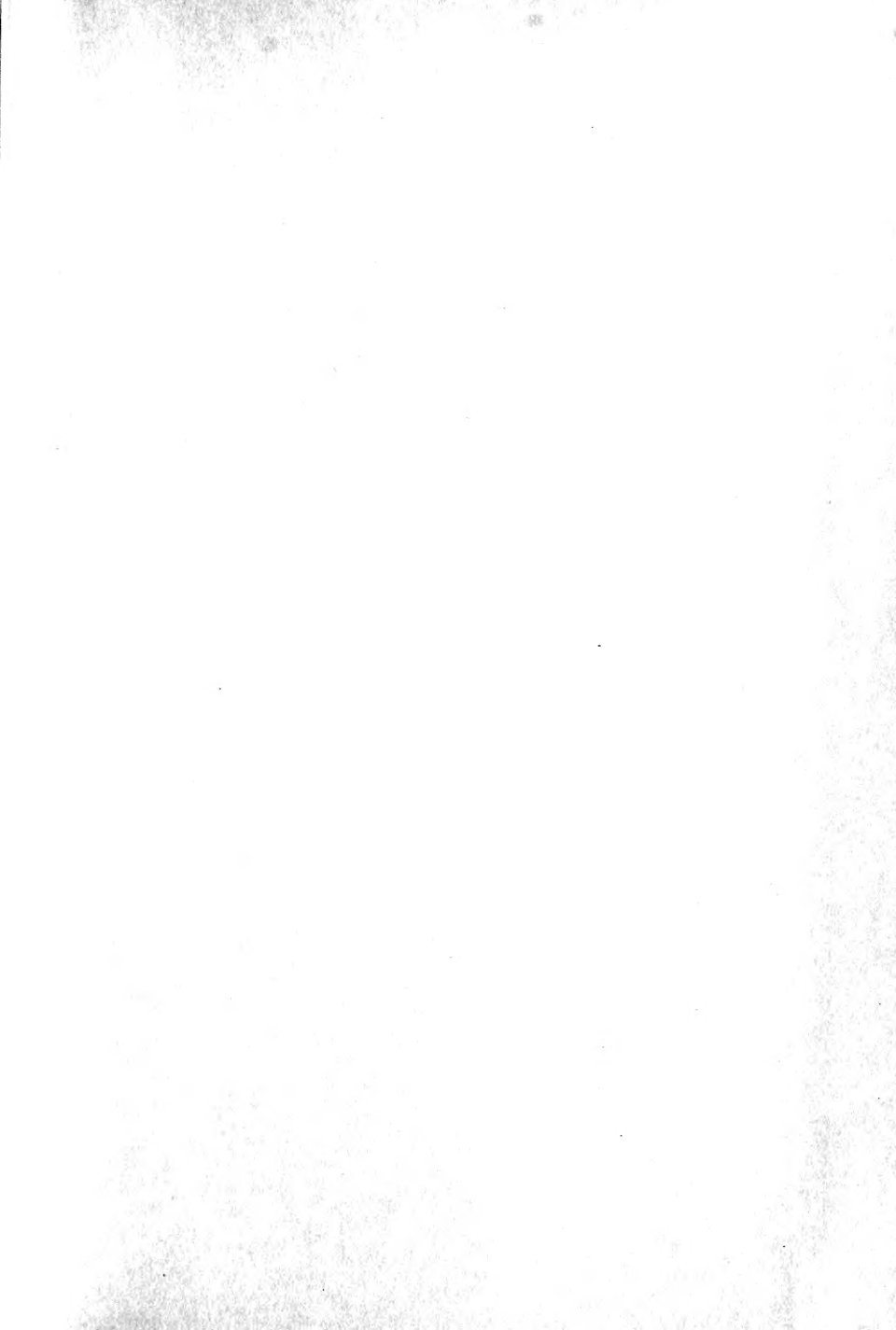

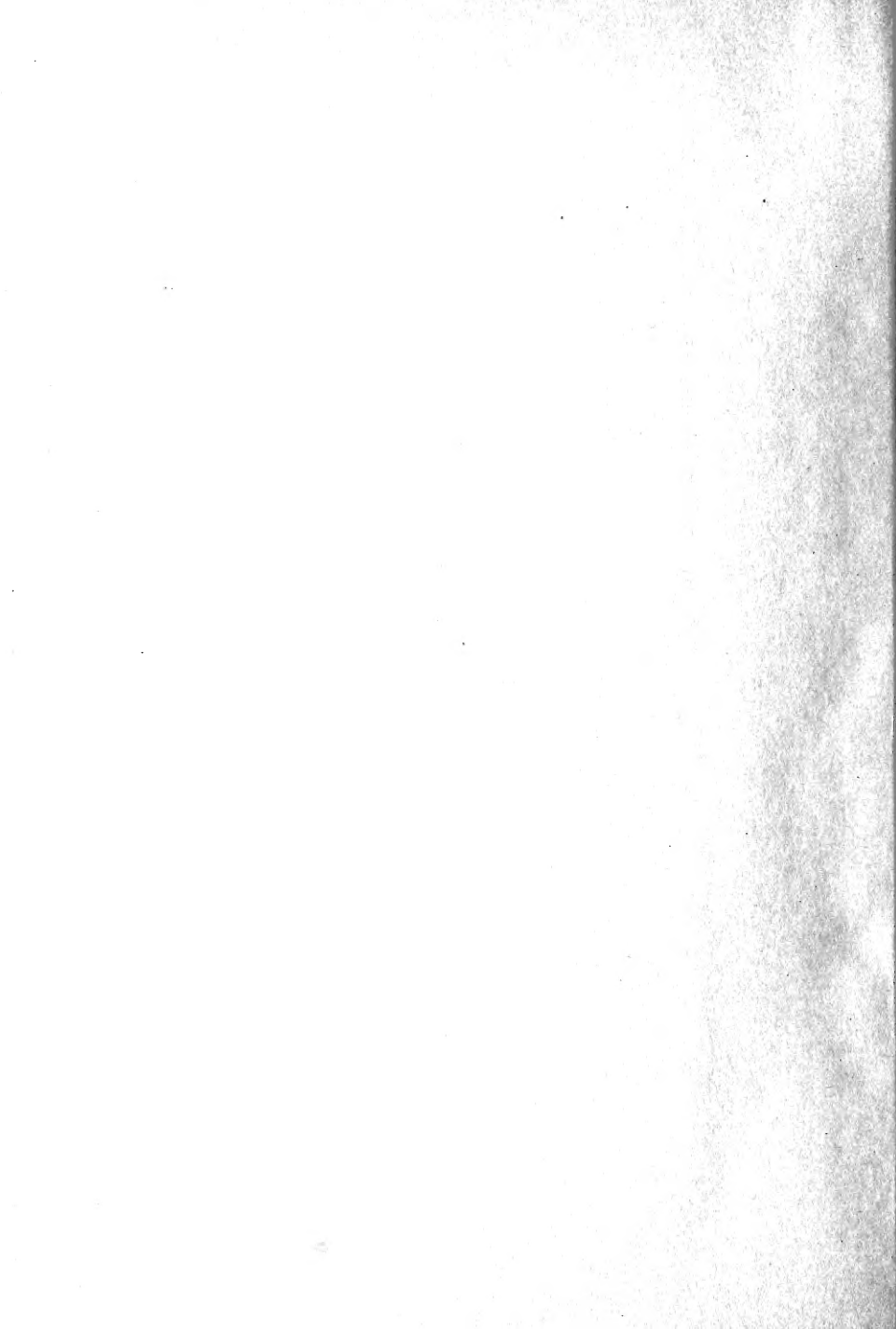



SMITHSONIAN INSTITUTION LIBRARIES



3 9088 01359 7067